

# Service Manual

## Tuner

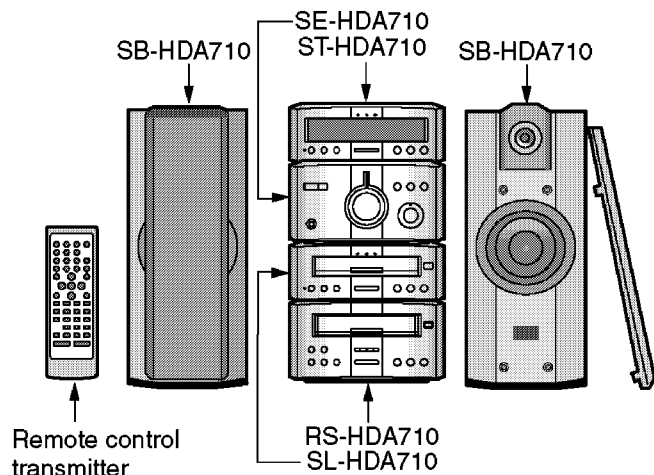

## ST-HDA710

Colour

(N) .....Gold Type

Area

E .....Europe.

System: SC-HDA710

Because of unique interconnecting cables,when a component requires servise,send or bring in the entire system.

Note: Refer to the service manual for Model No. SE-HDA710 (ORDER NO.AD0008145C2) for information on "ACCESSORIES"and "PACKAGING".

## Specification

### ●Pre-amplifier section

#### Input sensitivity/impedance

EXTERNAL: 250mV/15k $\Omega$

#### Output level

EXTERNAL: 250mV/1.5k $\Omega$

### ●FM tuner section

Frequency range: 87.50-108.00MHz(0.05MHz step)

Antenna terminals: 75 $\Omega$ (unbalance)

### ●AM tuner section

Frequency range: 522-1629kHz(9kHz step)

520-1630kHz(10kHz step)

### ●Timer section

Clock: Quartz-lock type

Function: Play timer:1 time or everyday

Rec.timer:1 time or everyday

Sleep timer:120min., 30min. intervals

### ●General

Dimensions(WxHxD): 196x76.8x248mm

Weight: 1.1kg

Power Supply AC4.2V/13V,DC $\pm$ 13V/+16V/+10V/+5.6V

Power Consumption 15W

#### Notes:

- 1.Design and specifications are subject to change without notice.
- 2.Dimensions and weight are approximate.

### ●System

Tuner:ST-HDA710 ,DVD Audio/Video Player:SL-HDA710,

Amplifier:SE-HDA710,Cassette Deck:RS-HDA710,

Speakers:SB-HDA710 (Made in MAES)

## ⚠ WARNING

This service information is designed for experienced repair technicians only and is not designed for use by the general public. It does not contain warnings or cautions to advise non-technical individuals of potential dangers in attempting to service a product. Products powered by electricity should be serviced or repaired only by experienced professional technicians. Any attempt to service or repair the product or products dealt with in this service information by anyone else could result in serious injury or death.

## CONTENTS

	Page	Page
<b>1 Before Repair</b> .....	2	
<b>2 Operating Instructions</b> .....	2	
<b>3 About the Self-Diagnostic Mode</b> .....	3	
<b>4 Power Source ON/OFF and Signal Check</b> .....	4	
<b>5 Operation Checks and Component Replacement Procedures</b>		
5.1. Checking for the in/out jack P.C.B. and volume P.C.B. ....	5	
5.2. Checking for the main P.C.B. ....	5	
<b>6 Wiring Connection Diagram</b> .....	6	
<b>7 Block Diagram</b> .....	7	
<b>8 Schematic Diagram Notes</b> .....	11	
		8.1. Schematic Diagram Notes .....
		8.2. Type Illustrations of IC 痲, Transistors and Diodes .....
		<b>9 Schematic Diagram</b> .....
		<b>10 Printed Circuit Board Diagram</b> .....
		<b>11 Terminal Function of IC's</b> .....
		11.1. IC404(M30803MG100F): SYSTEM CONTROL/FL DRIVE .....
		<b>12 Replacement Parts List</b> .....
		<b>13 Cabinet Parts Location</b> .....

## 1 Before Repair

This equipment (ST-HDA710), which is the component of the system, is supplied with power from the amplifier (SE-HDA710).When repairing this equipment or checking operation

of the system, be sure to connect the amplifier with it.

Power supply and operation check in the state of it as a single equipment are impracticable.

## 2 Operating Instructions

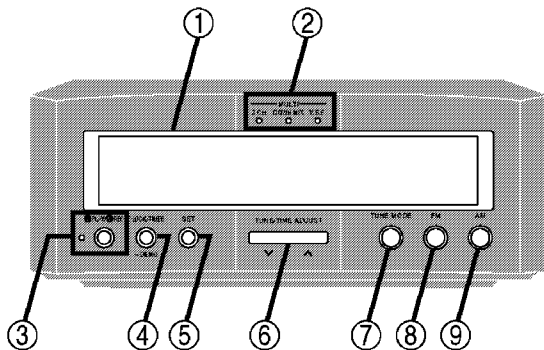

### ① Display panel

The display also shows information for the cassette deck, DVD Audio/Video player, and amplifier.

### ② Multiple sound indicators (MULTI)

When "DOWN MIX" is flashing

The DVD-Audio disc you are playing contains multiple-channel signals that cannot be down-mixed to be output through the two front speakers. "CANNOT DOWN MIX" also appears on the display. Tracks that are recorded with such signals can only be played correctly if you have connected the same number of speakers as there are channels recorded. In some cases the same track will also be recorded in stereo (2 channels). Read the disc's jacket for details.

### ③ Play timer/record timer button and indicator

(⏪ PLAY/⏩ REC)

### ④ Clock/timer, demo button

(CLOCK/TIMER, -DEMO)

### ⑤ Set button (SET)

### ⑥ Tuning/time adjust buttons

(TUNE/TIME ADJUST V, ^)

### ⑦ Tuning mode button (TUNE MODE)

### ⑧ FM band select button (FM)

### ⑨ AM band select button (AM)

### 3 About the Self-Diagnostic Mode

This unit is equipped with a self-diagnostic function which, in the event of a malfunction, automatically displays a code

indicating the nature of the malfunctions. Use this self-diagnostic function when servicing the unit.

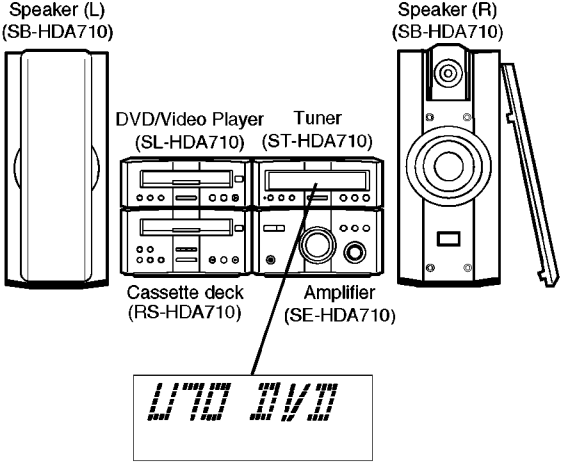
Display method	Display location
<p><b>To display the malfunction code</b></p> <p>U70 DVD..... Automatically displays on the tuner when a malfunction occurs.</p> <p>F61..... Automatically displays on the tuner when a malfunction occurs.</p> <p><b>To return the normal display</b></p> <p><b>1.For U70 DVD:</b></p> <ul style="list-style-type: none"> <li>• Press an any operation button on the tuner.</li> <li>• To re-display the code, switch the power off (POWER STANDBY button), and then switch power back on again.</li> </ul> <p><b>2.For F61:</b></p> <ul style="list-style-type: none"> <li>• If F61 is displayed, the power will automatically be switched off.</li> <li>• F61 will be displayed for 3 seconds, and then the clock will be displayed.</li> <li>• To re-display the code, switch the power on. F61 will be re-displayed, and then after 3 seconds the clock will be displayed and the power will automatically switch off.</li> </ul>	

#### Display contents

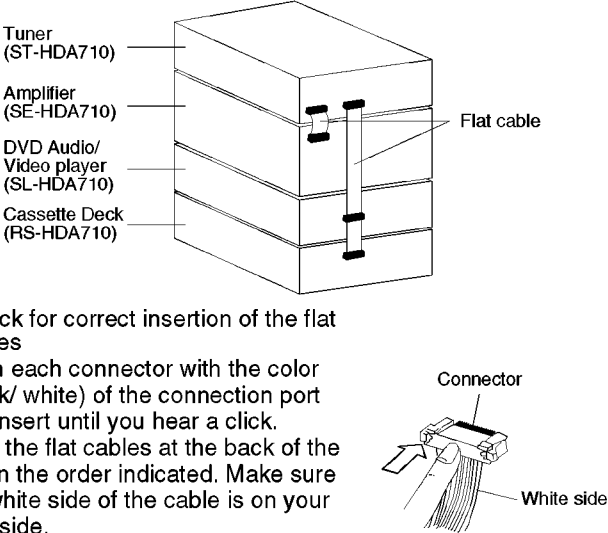
Display code	Problem or condition	Correction procedure
<p><b>U70 DVD</b> (displayed automatically)</p>	<p>A bus-line communications error has occurred as a result of the flat cables being inserted incorrectly, thus preventing the system from operating.</p> <p>1. If U70 is displayed on the tuner, the Cassette deck or DVD/Video player cannot be operated by remote control.</p>	 <p>1. To check for correct insertion of the flat cables</p> <ol style="list-style-type: none"> <li>1 Match each connector with the color (black/ white) of the connection port and insert until you hear a click.</li> <li>2 Insert the flat cables at the back of the unit in the order indicated. Make sure the white side of the cable is on your right side.</li> </ol> <p>2. Breakage of flat cable (Check and replace as necessary.)</p> <p>3. If the problem is not corrected by items (1.) and (2.) above, this indicates a faulty IC.</p> <p>U70DVD [ <b>ST-HDA710:</b> IC404 (M30803MG100F) <b>SL-HDA710:</b> IC201 (C2BBFD000226)</p> <p>Check these IC's and replace as necessary.</p>
<p><b>F61</b></p>	<p>When the power switch is switched on, it automatically switches back off, making it impossible to switch power on.</p>	<ul style="list-style-type: none"> <li>• Faulty amplifier (SE-HDA710) output IC. (When a DC voltage is applied to the speaker terminals.)</li> </ul>

## 4 Power Source ON/OFF and Signal Check

To operate this unit ST-HDA710 normally, it is necessary for connecting to the unit SE-HDA710.

When operating the unit ST-HDA710, be sure to connect the unit SE-HDA710 by connection cable.

1. Short the section between J370 (A.GND) and J704(D.GND), and as well as the section between J703(CT) and J704(D.GND).(As shown in Fig. 1 .)
2. Connect with the Amplifier (SE-HDA710).(As shown in Fig. 1 .)

3. Connect the AC mains lead to Amplifier (SE-HDA710).(As shown in Fig. 1 .)
4. Connect the speakers to speaker input terminal.(As shown in Fig. 1 .)
5. Turn on the power of the Amplifier (SE-HDA710).
6. Press INPUT SELECTOR to select the external source (EXT) of the Amplifier (SE-HDA710).
7. Input a sound signal to external input terminal of Tuner (ST-HDA710), and confirm to be outputted from the speaker.

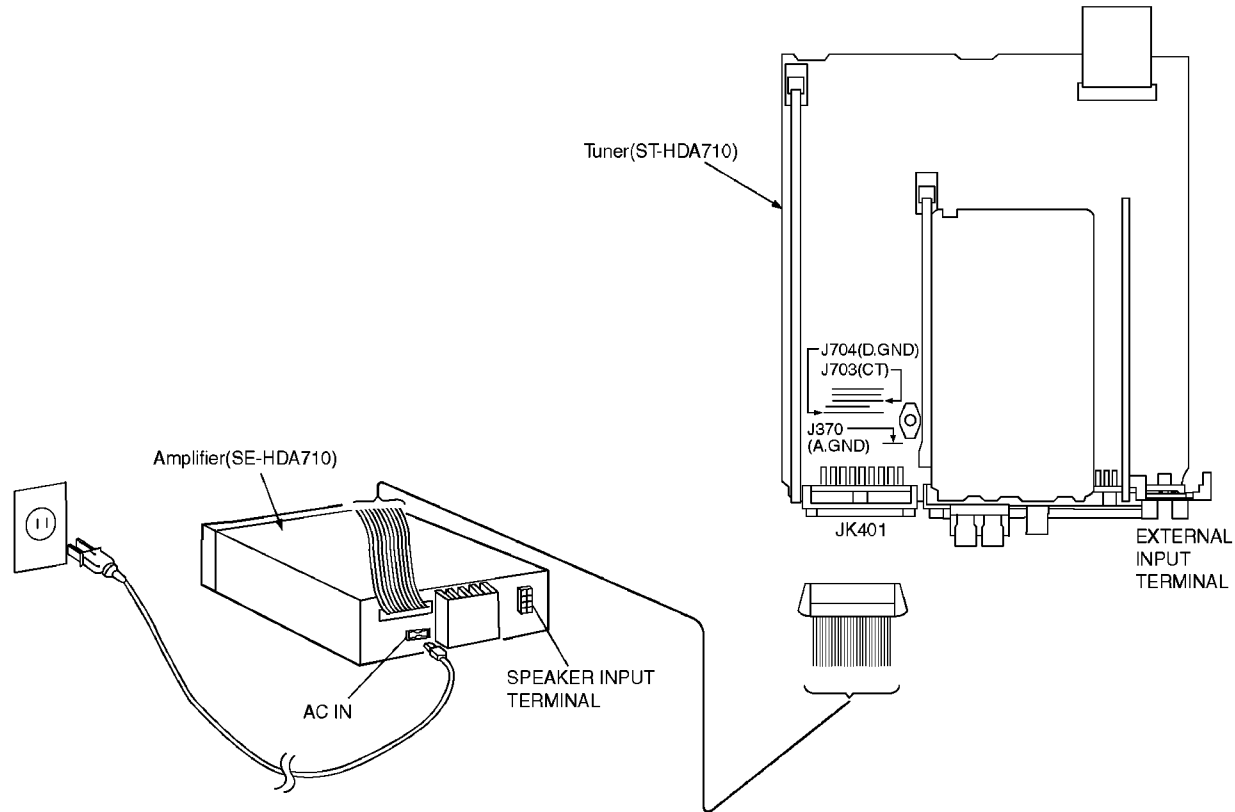
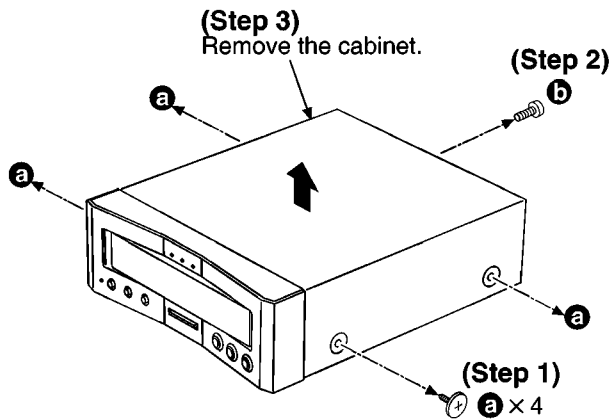

Fig. 1

## 5 Operation Checks and Component Replacement Procedures

- This section describes procedures for checking the operation of the major printed circuit boards and replacing the main components.
- For reassembly after operation checks or replacement, reverse the respective procedures. Special reassembly procedures are described only when required.

### 5.1. Checking for the in/out jack P.C.B. and volume P.C.B.



- Check the in/out jack P.C.B. and volume P.C.B. as shown below.

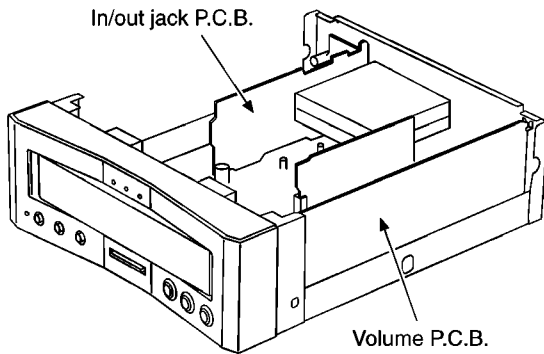

### 5.2. Checking for the main P.C.B.

- Follow the (Step 1) - (Step 3) of item 5.1.

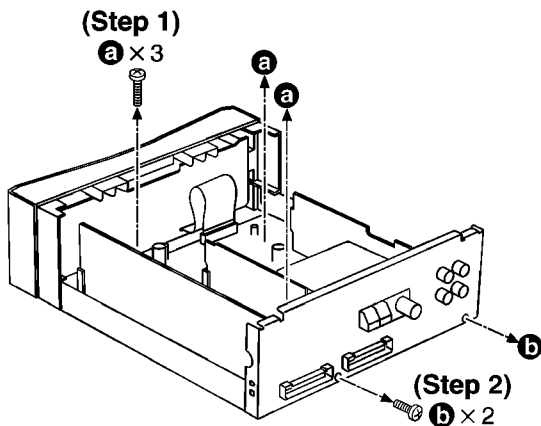

#### NOTE:

Make sure the rib are fit in the hole when assembling the main P.C.B..

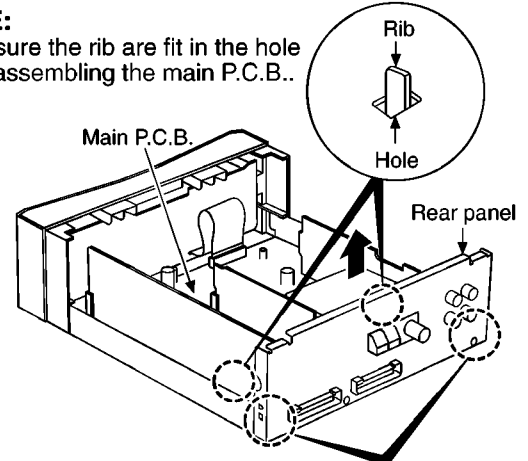

#### (Step 3)

Release the 2 claws, and then remove the rear panel.

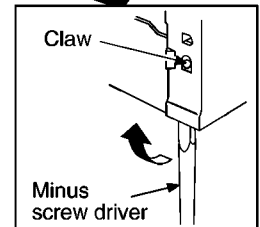

- Check the main P.C.B. as shown below.

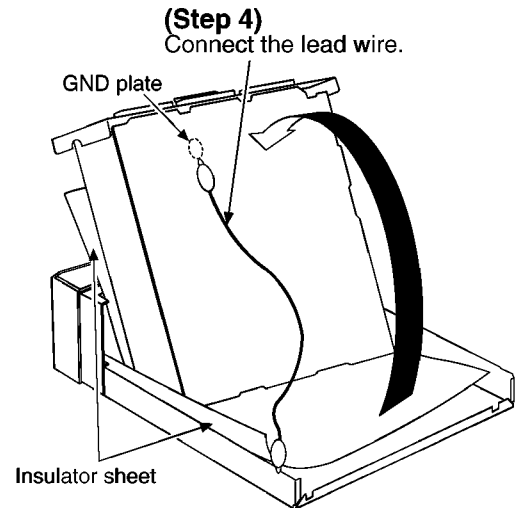

# 6 Wiring Connection Diagram

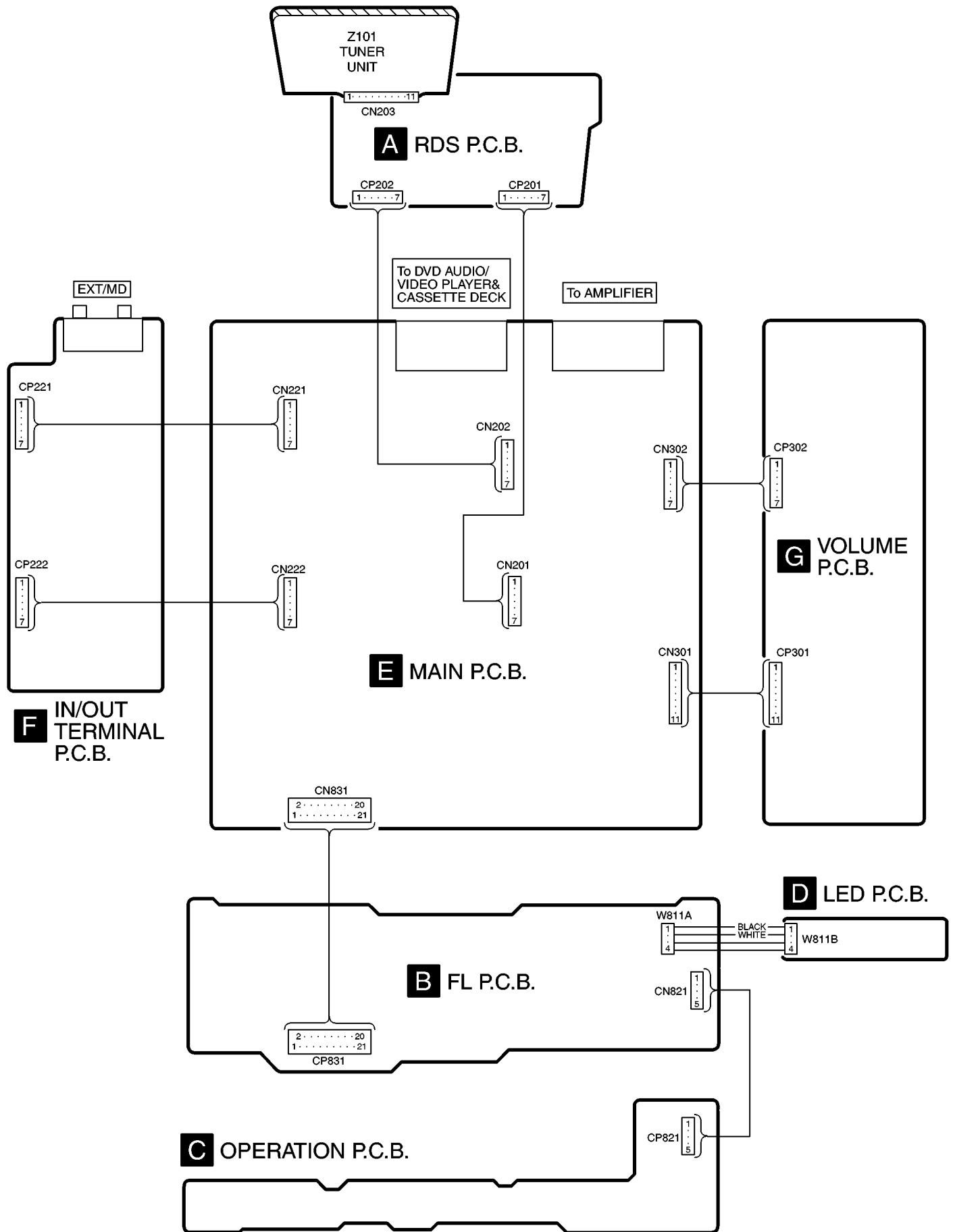

# 7 Block Diagram

Z101 TUNER UNIT (RAN0005EM-1)

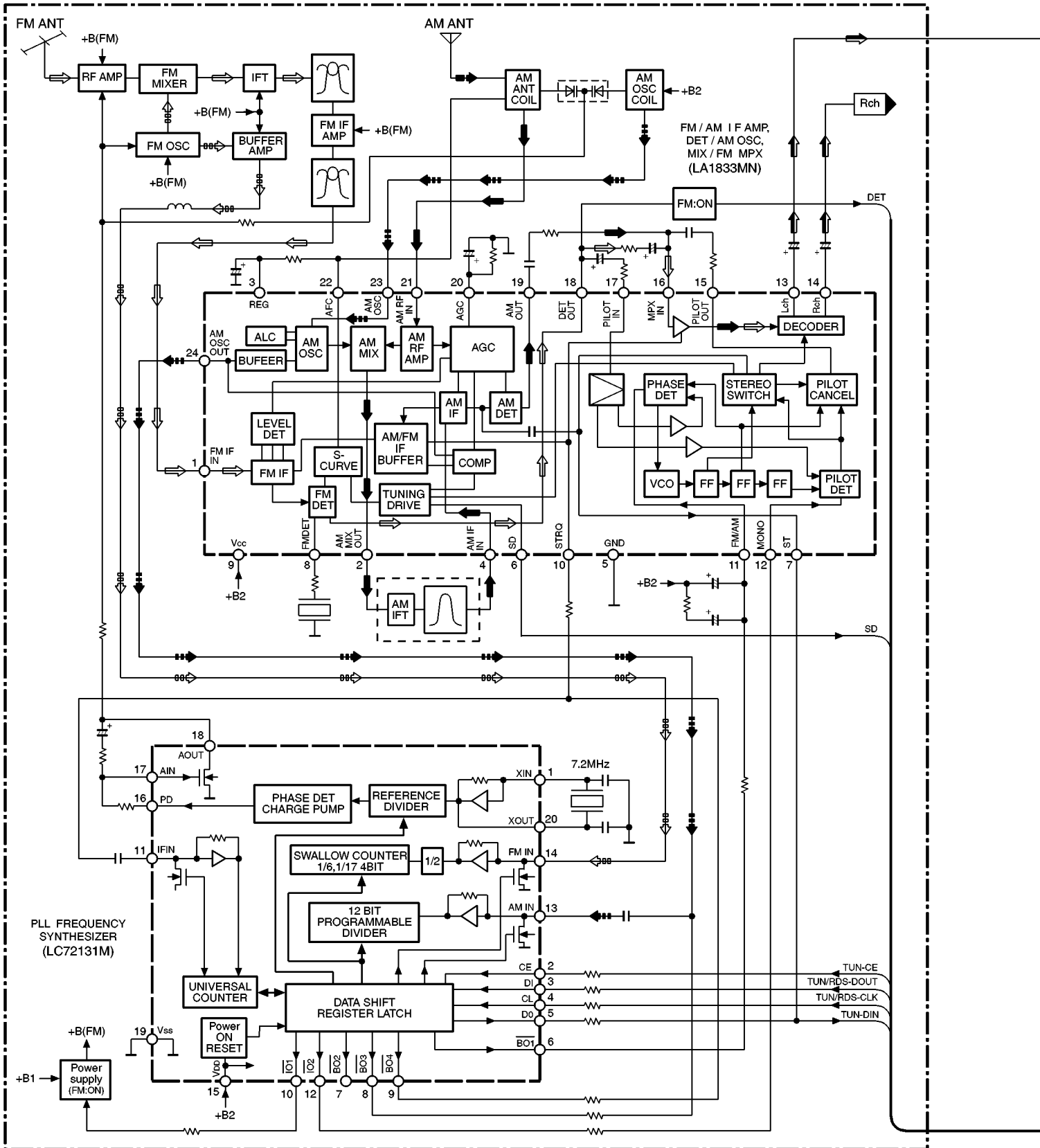

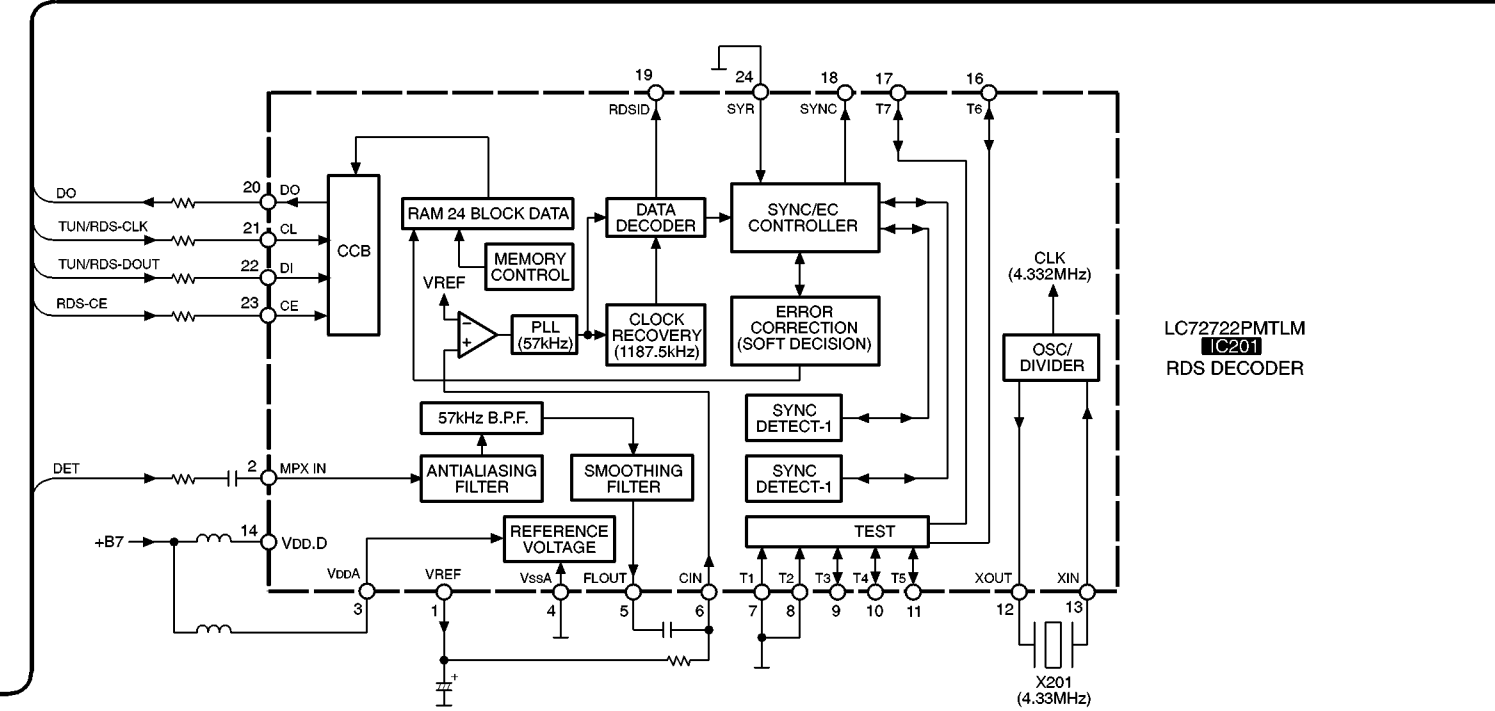
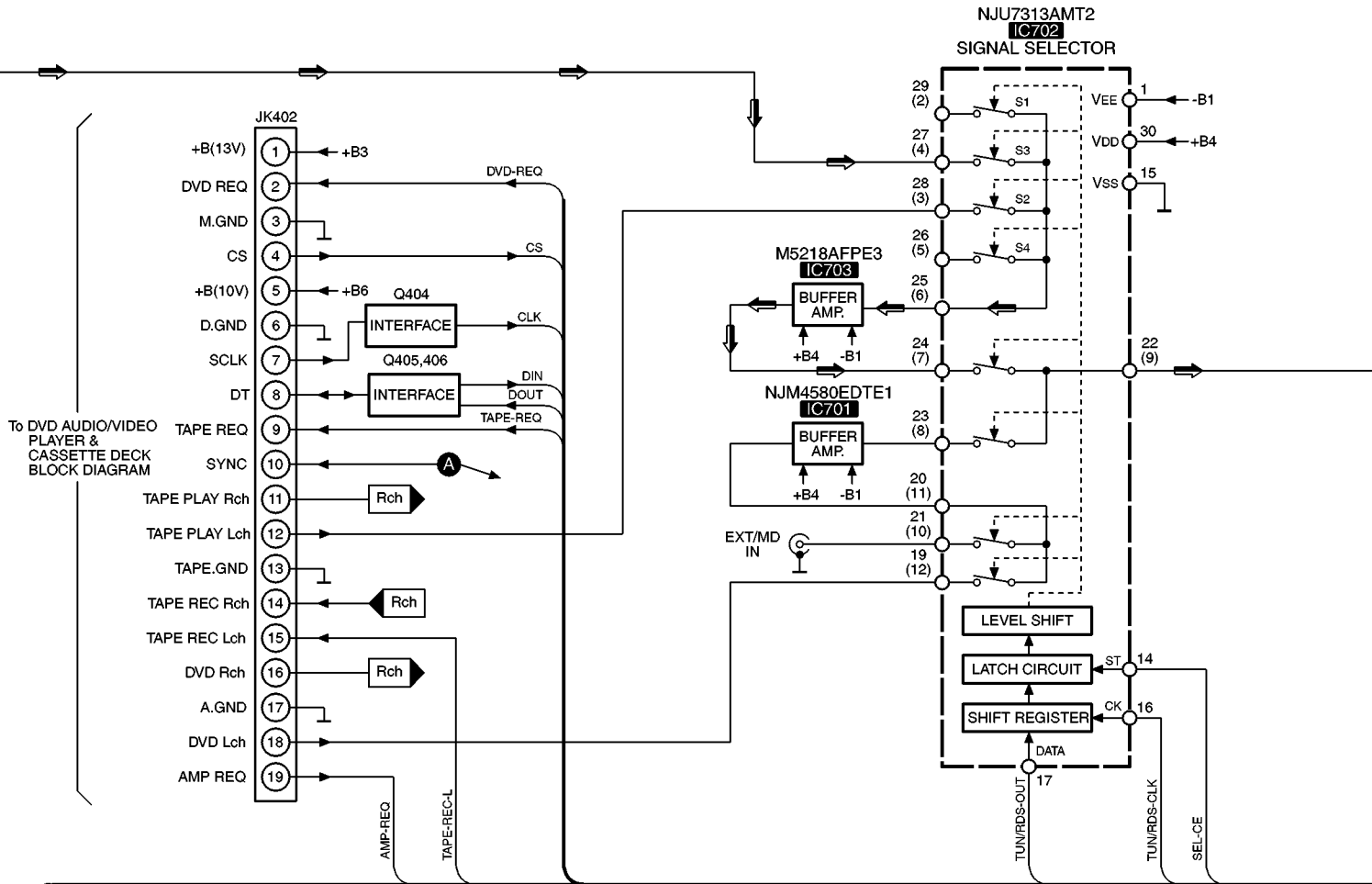



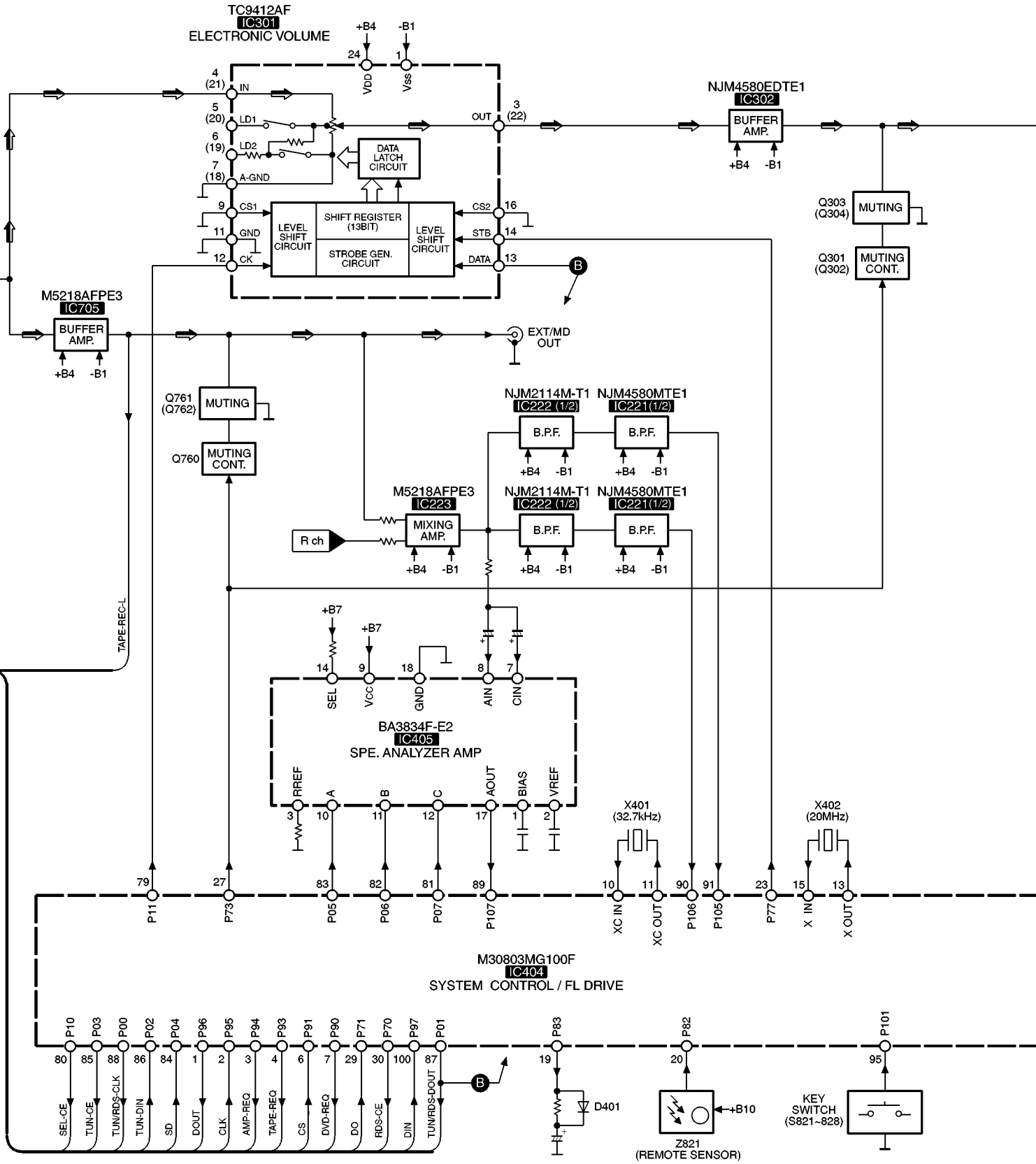

NOTE

- ◀: FM SIGNAL LINE
- ◀◀: FM OSC SIGNAL LINE
- ▶: AM SIGNAL LINE
- ▶▶: AM OSC SIGNAL LINE
- ◀▶: FM/AM SIGNAL LINE
- ( ) indicates pin No. Right channel.

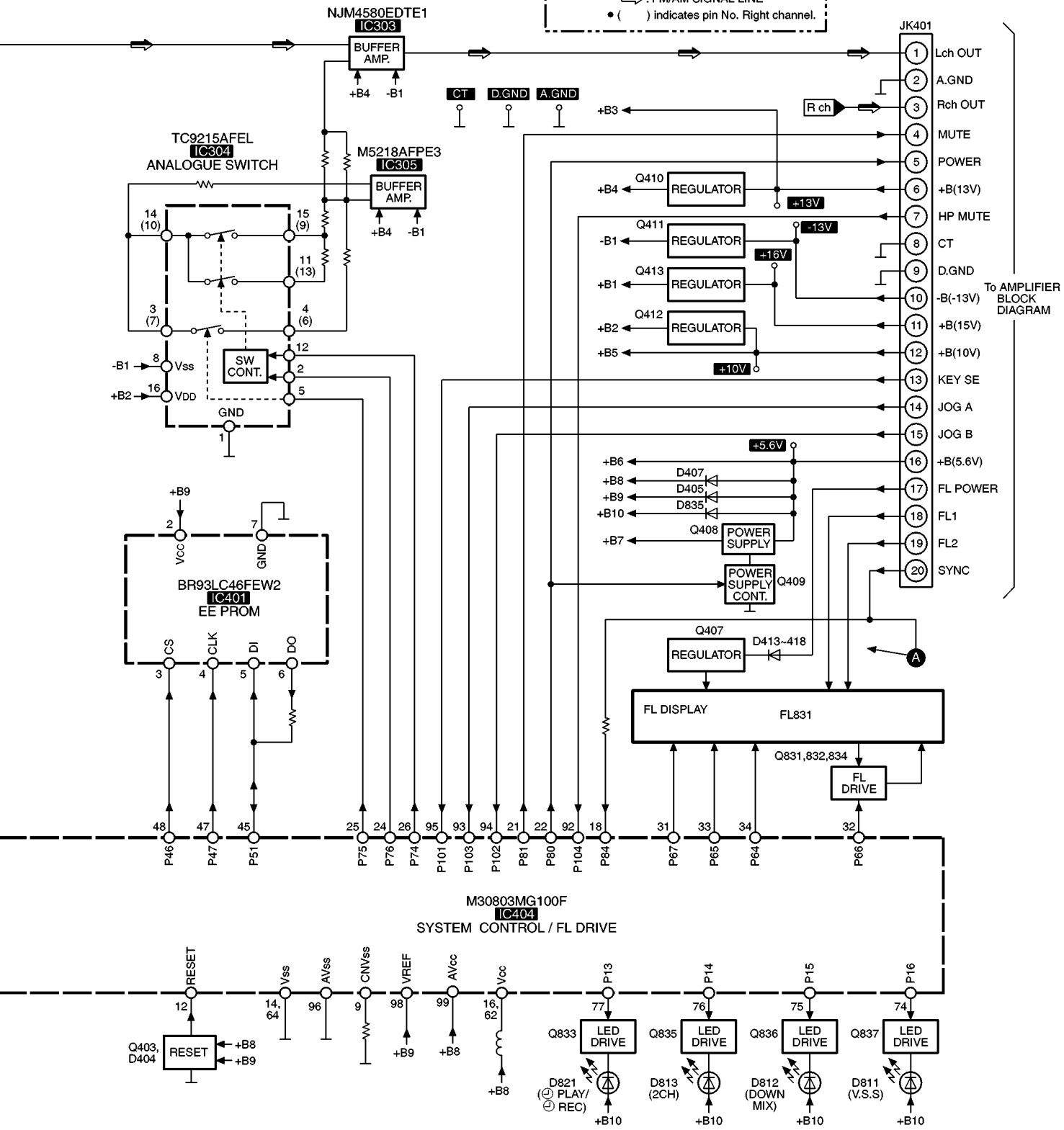

To AMPLIFIER BLOCK DIAGRAM

# 8 Schematic Diagram Notes

## 8.1. Schematic Diagram Notes

· This schematic diagram may be modified at any time with development of new technology.

**Notes:**

- S821: AM band select (AM) switch.
- S822: FM band select (FM) switch.
- S823: Tuning mode (TUNE MODE) switch .
- S824: Tuning/time adjust (  $\wedge$  ) switch .
- S825: Tuning/time adjust (  $\vee$  ) switch.
- S826: Set (SET) switch.
- S827: Clock/timer, demo (CLOCK/TIMER,-DEMO) switch.
- S828: Play timer/record timer (  $\odot$  PLAY/REC  $\odot$  ) switch.
- Indicated voltage values are the standard values for the unit measured by the DC electronic circuit tester (high-impedance) with the chassis taken as standard. Therefore, there may exist some errors in the voltage values, depending on the internal impedance of the DC circuit tester.

No mark: FM mode

( ): AM mode

**Important safety notice:**

Components identified by  $\triangle$  mark have special characteristics important for safety.

Furthermore, special parts which have purpose of fire-retardant (resistors), high-quality sound (capacitors), low-noise (resistors), etc. are used. When replacing any of components, be sure to use only manufacturer's specified parts shown in the parts list.

**Caution!**

- IC and LSI are sensitive to static electricity.
- Secondary trouble can be prevented by taking care during repair.
- Cover the parts boxes made of plastics with aluminum foil.
- Ground the soldering iron.
- Put a conductive mat on the work table.
- Do not touch the legs of IC or LSI with the fingers directly.

**Voltage and signal line**

- $\rightarrow$  : Positive voltage line
- $\Rightarrow$  : FM signal line
- $\rightarrow$  : AM signal line
- $\dashrightarrow$  : Negative voltage line
- $\Rightarrow$  : FM OSC signal line
- $\Rightarrow$  : AM OSC signal line
- $\Rightarrow$  : FM/AM Signal line

## 8.2. Type Illustrations of IC's, Transistors and Diodes

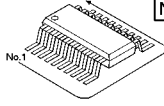
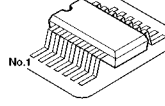
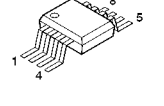
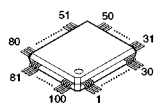
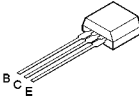
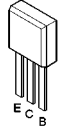
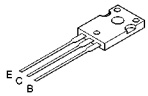
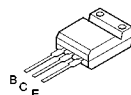
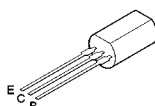
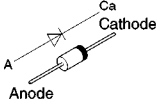
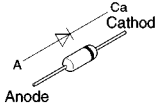
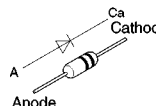
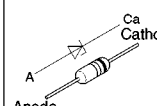
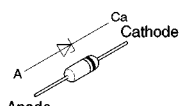
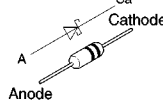
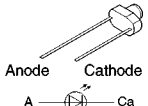
 <table border="1" data-bbox="438 1276 641 1354"> <tr><td>BA3834F-E2</td><td>18PIN</td></tr> <tr><td>LC72722PMTLM</td><td>24PIN</td></tr> <tr><td>NJU7313AMT2</td><td>30PIN</td></tr> </table>		BA3834F-E2	18PIN	LC72722PMTLM	24PIN	NJU7313AMT2	30PIN	 <table border="1" data-bbox="803 1276 1006 1333"> <tr><td>TC9215AFEL</td><td>16PIN</td></tr> <tr><td>TC9412AF</td><td>24PIN</td></tr> </table>		TC9215AFEL	16PIN	TC9412AF	24PIN	 <table data-bbox="1201 1297 1347 1417"> <tr><td>BR93LC46FEW2</td></tr> <tr><td>M5218AFPE3</td></tr> <tr><td>NJM2114M-T1</td></tr> <tr><td>NJM4580EDTE1</td></tr> <tr><td>NJM4580MTE1</td></tr> </table>		BR93LC46FEW2	M5218AFPE3	NJM2114M-T1	NJM4580EDTE1	NJM4580MTE1
BA3834F-E2	18PIN																			
LC72722PMTLM	24PIN																			
NJU7313AMT2	30PIN																			
TC9215AFEL	16PIN																			
TC9412AF	24PIN																			
BR93LC46FEW2																				
M5218AFPE3																				
NJM2114M-T1																				
NJM4580EDTE1																				
NJM4580MTE1																				
<p>M30803MG100F</p> 	 <p>DTA114TSTP 2SD2144STA DTB123YSTP DTC114ESTP DTC143XSTP</p>	 <p>2SA1309ATA 2SC3311ATA UN4214TA</p>	<p>2SD2343</p> 																	
<p>2SB1417PQTA 2SD2137PQTA</p> 	<p>2SC3940AQSTA</p> 	<p>RL1N4003N02</p>  <p>Ca Cathode Anode</p>	<p>MA165TA</p>  <p>Ca Cathode Anode</p>	<p>MA185TA 1SS291TA</p>  <p>Ca Cathode Anode</p>	<p>MA4051MTA MA4082LTA</p>  <p>Ca Cathode Anode</p>															
<p>MA4240MTA MA4100MTA</p>  <p>Ca Cathode Anode</p>	<p>MA719TA</p>  <p>Ca Cathode Anode</p>	<p>SLR325VCT31 SLR325YCT31</p>  <p>Anode Cathode A Ca</p>																		

# 9 Schematic Diagram

## SCHEMATIC DIAGRAM-1

NOTE:  
The number which noted at the connectors on the schematic diagram as "SCHEMATIC DIAGRAM-1" or "SCHEMATIC DIAGRAM-2" indicates the schematic diagram serial number located on the left corner in the schematic diagram.

To TUNER UNIT on SCHEMATIC DIAGRAM-10

### A RDS CIRCUIT

→ : POSITIVE VOLTAGE LINE    ⇨ : FM/AM SIGNAL LINE

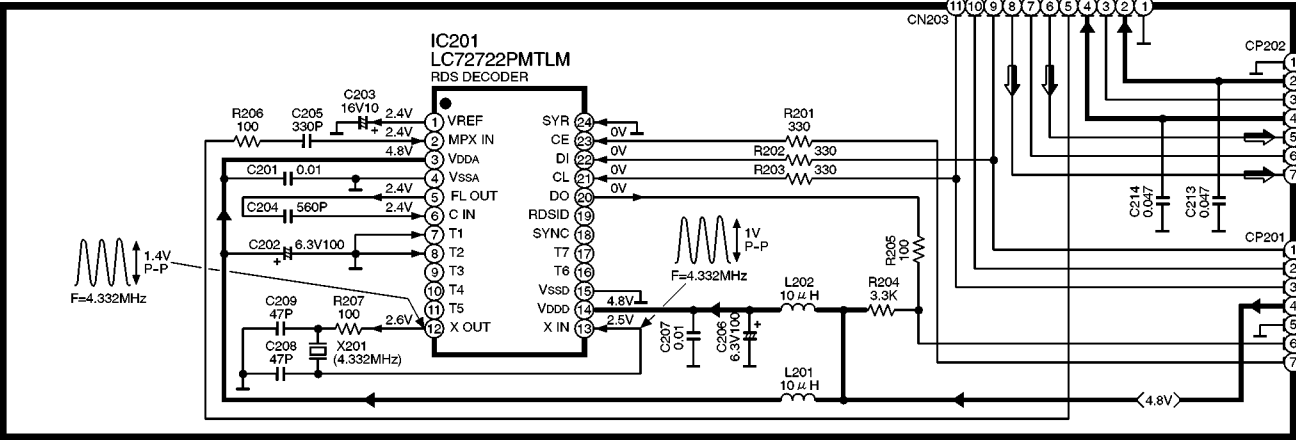

### B FL CIRCUIT

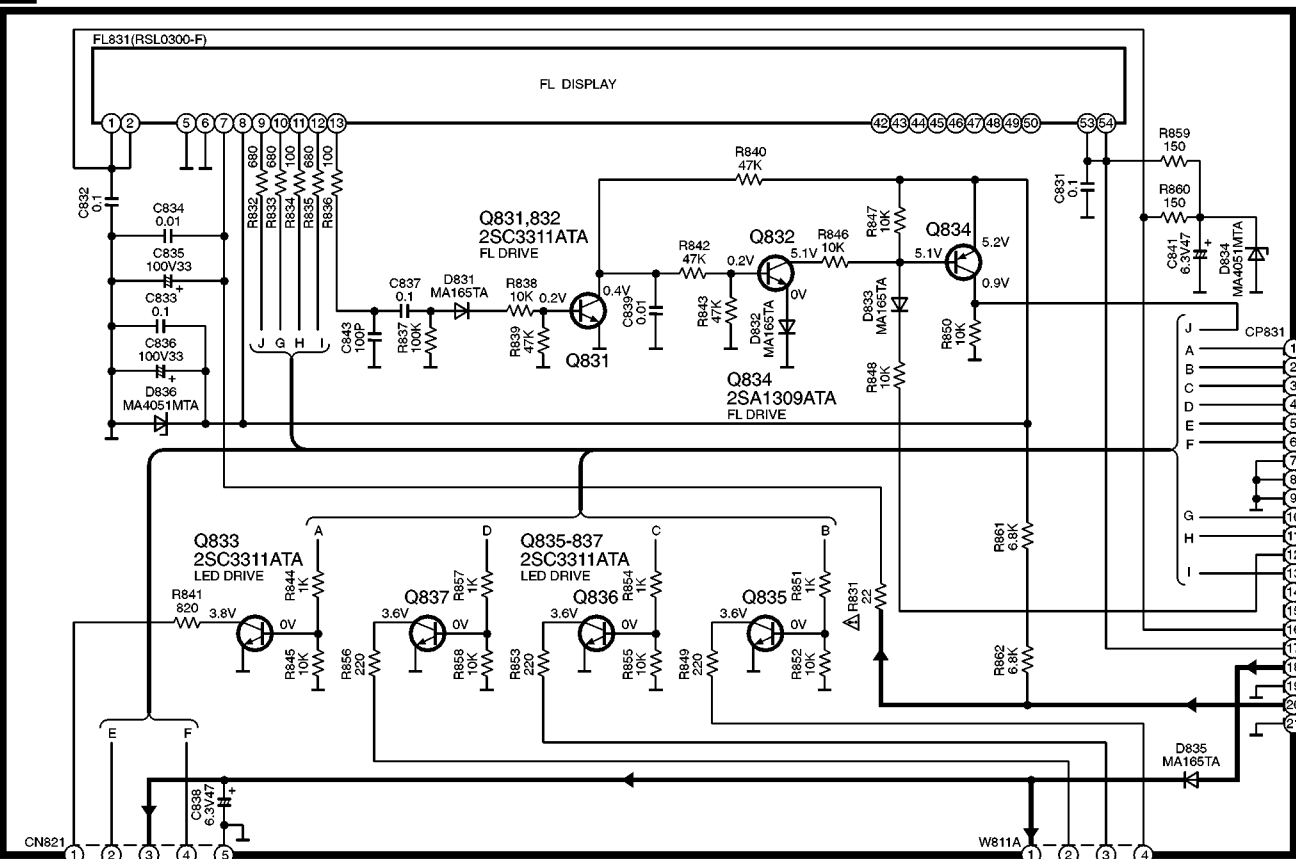

### C OPERATION CIRCUIT

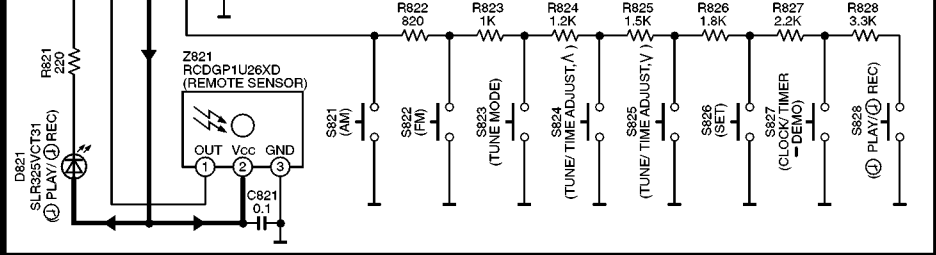

### D LED CIRCUIT

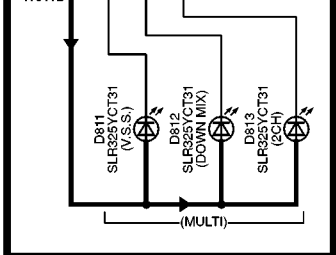

SCHEMATIC DIAGRAM-2

**E** MAIN CIRCUIT

→ : POSITIVE VOLTAGE LINE    ⇨ : FM/ AM SIGNAL LINE

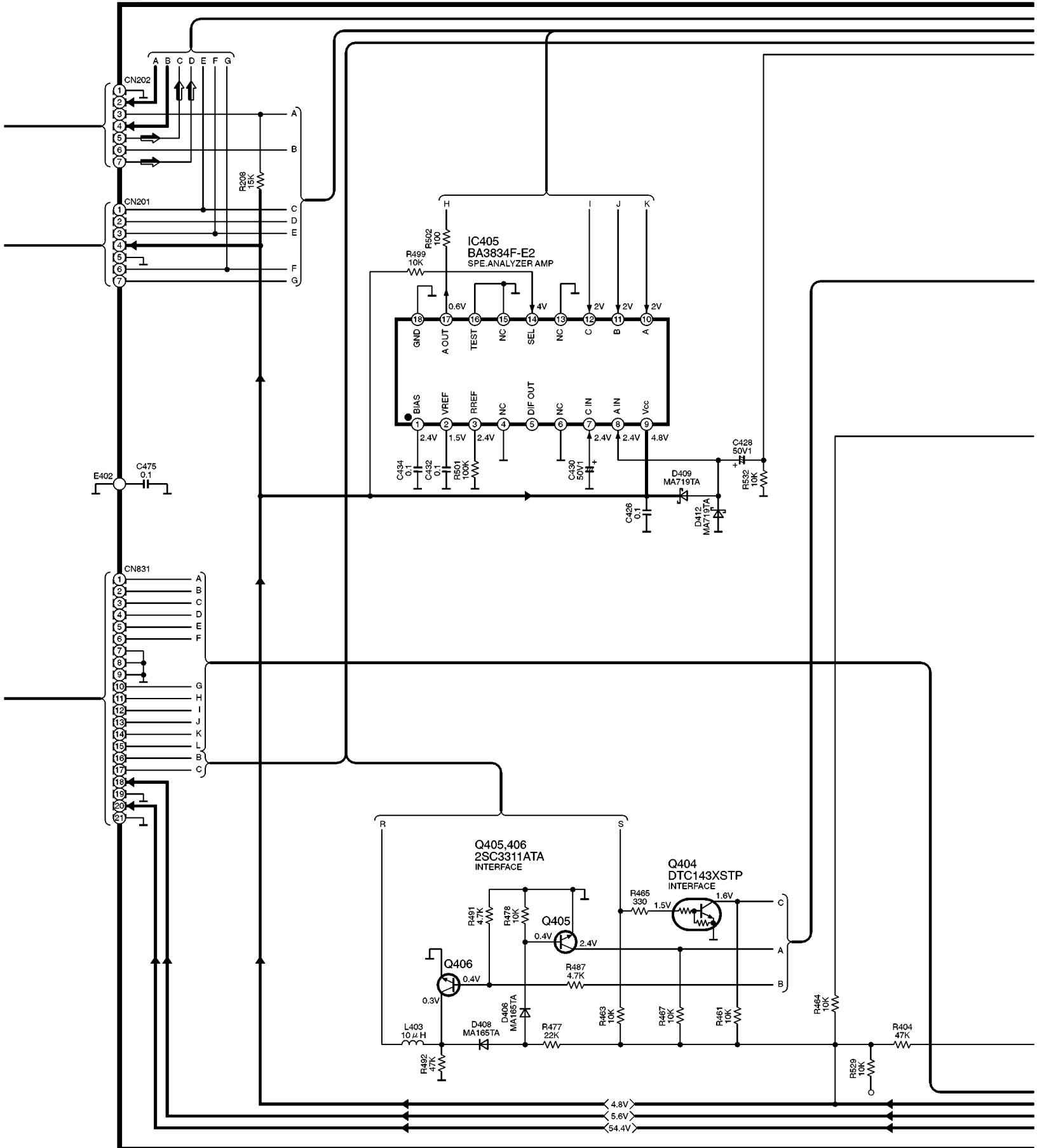

SCHEMATIC DIAGRAM-3

→ : POSITIVE VOLTAGE LINE

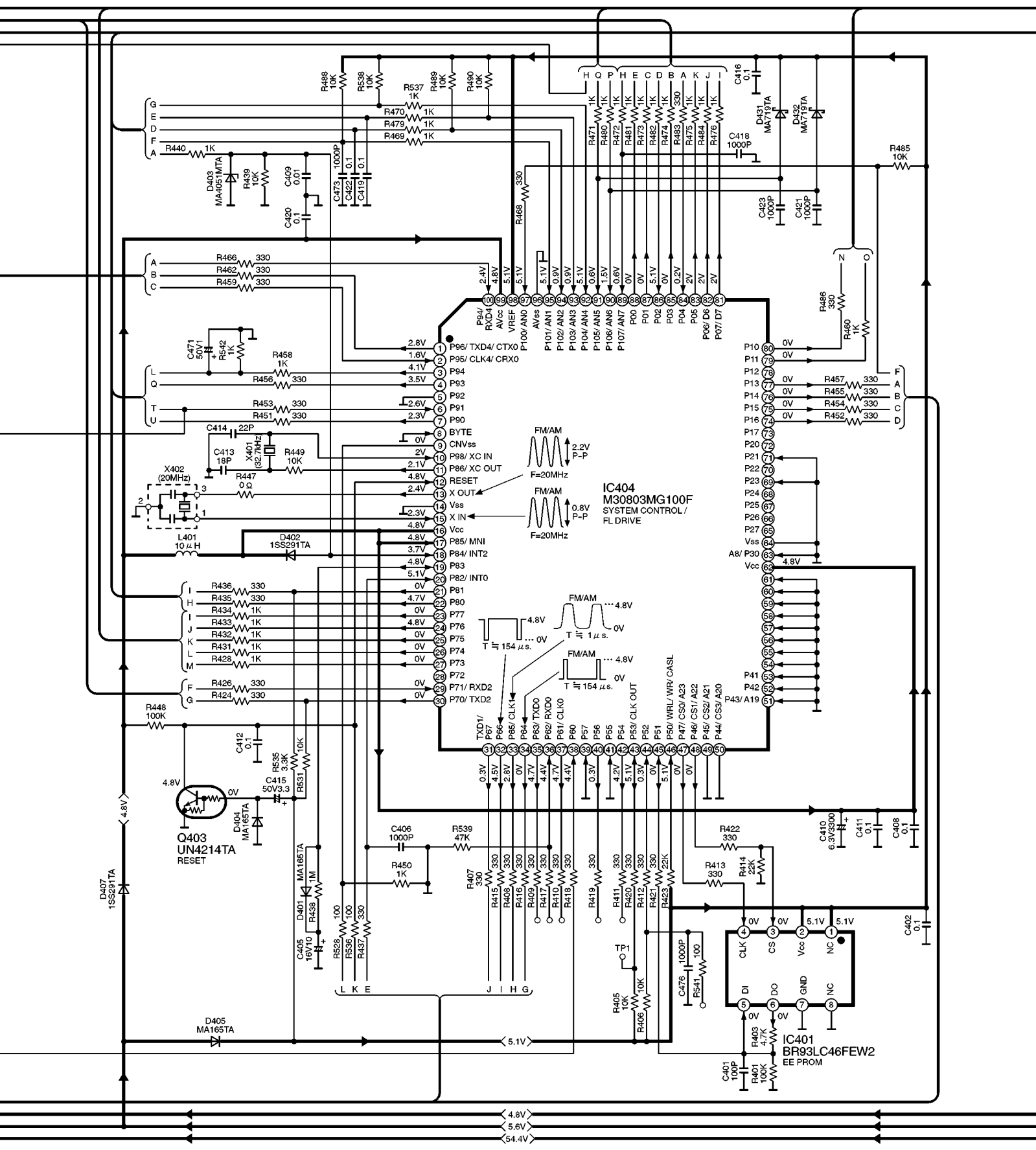

SCHEMATIC DIAGRAM-4

F IN/ OUT TERMINAL CIRCUIT

→ : POSITIVE VOLTAGE LINE    → : FM/ AM SIGNAL LINE  
- - - - - : NEGATIVE VOLTAGE LINE

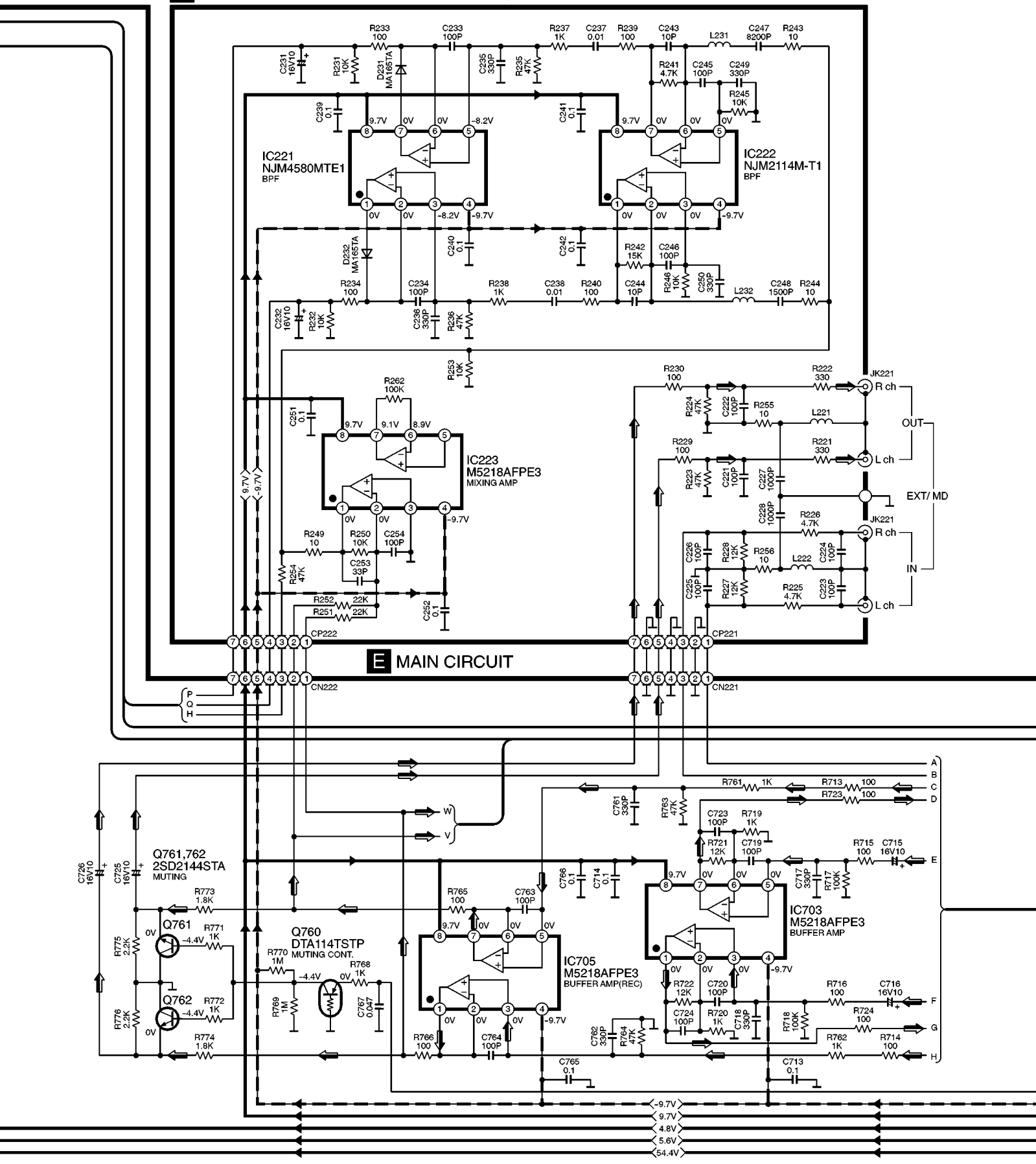

SCHEMATIC DIAGRAM-5

**G** VOLUME CIRCUIT

→ : POSITIVE VOLTAGE LINE    → - : NEGATIVE VOLTAGE LINE    ⇨ : FM/AM SIGNAL LINE

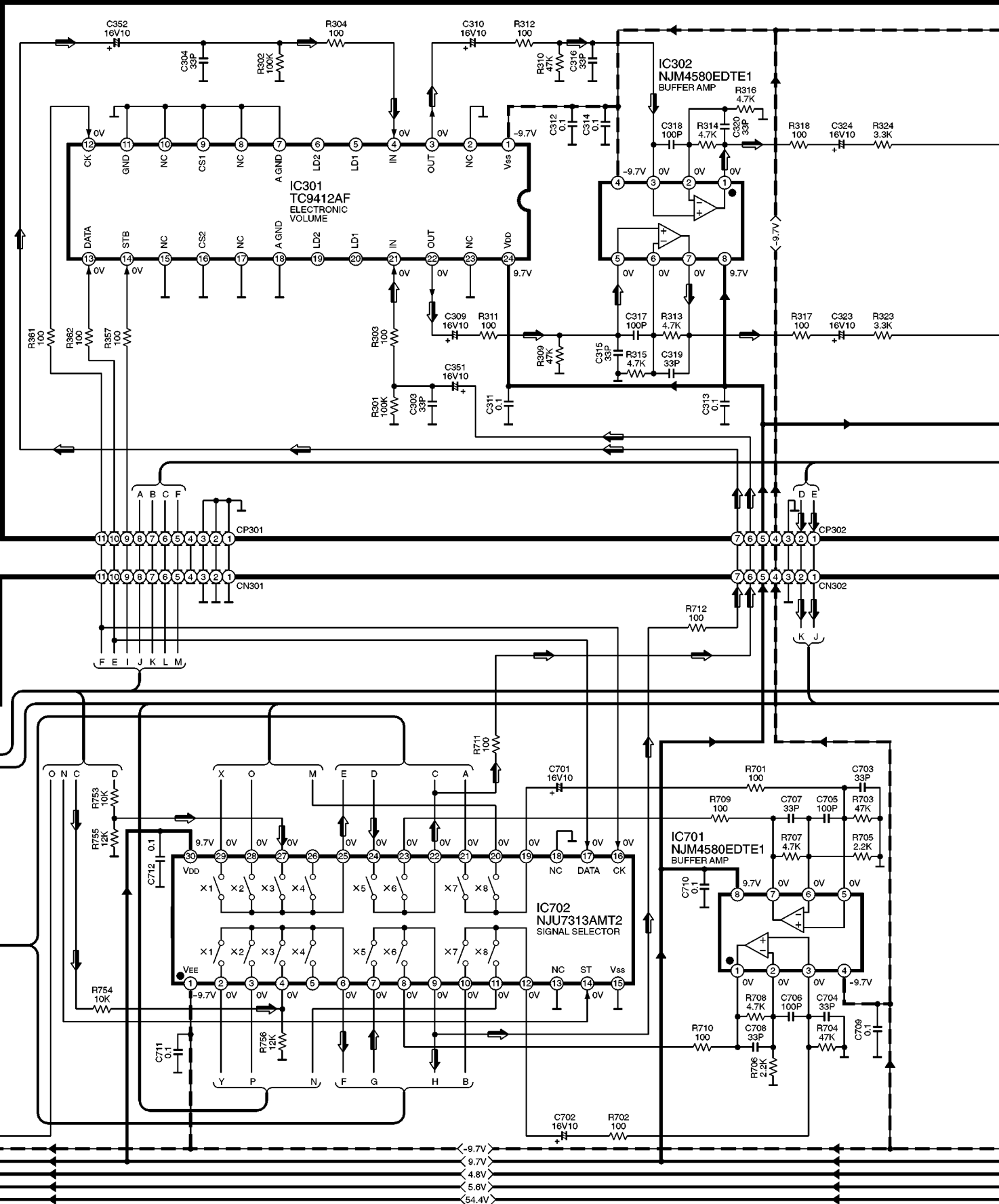



SCHEMATIC DIAGRAM-6

→ : POSITIVE VOLTAGE LINE    - - - - - : NEGATIVE VOLTAGE LINE    ⇨ : FM/AM SIGNAL LINE

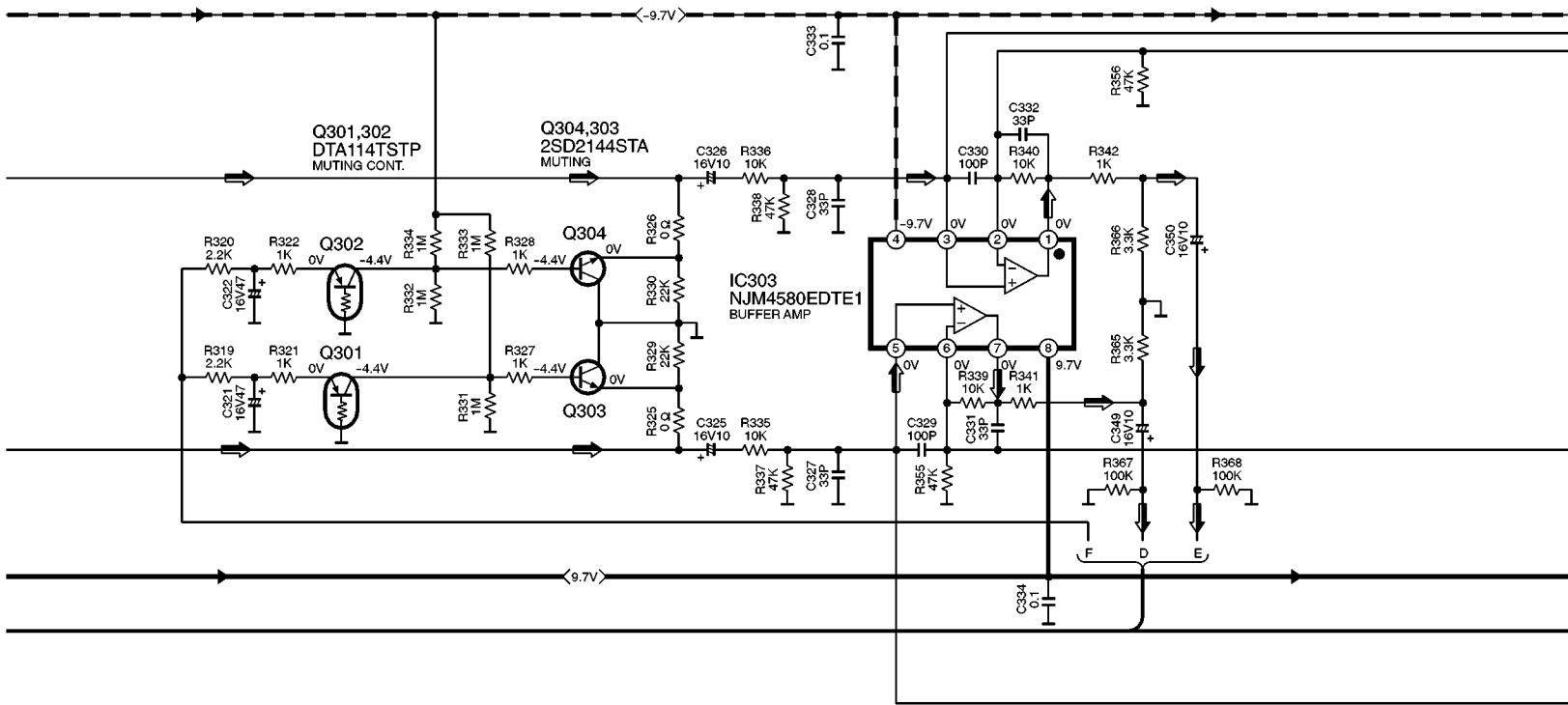

**E** MAIN CIRCUIT

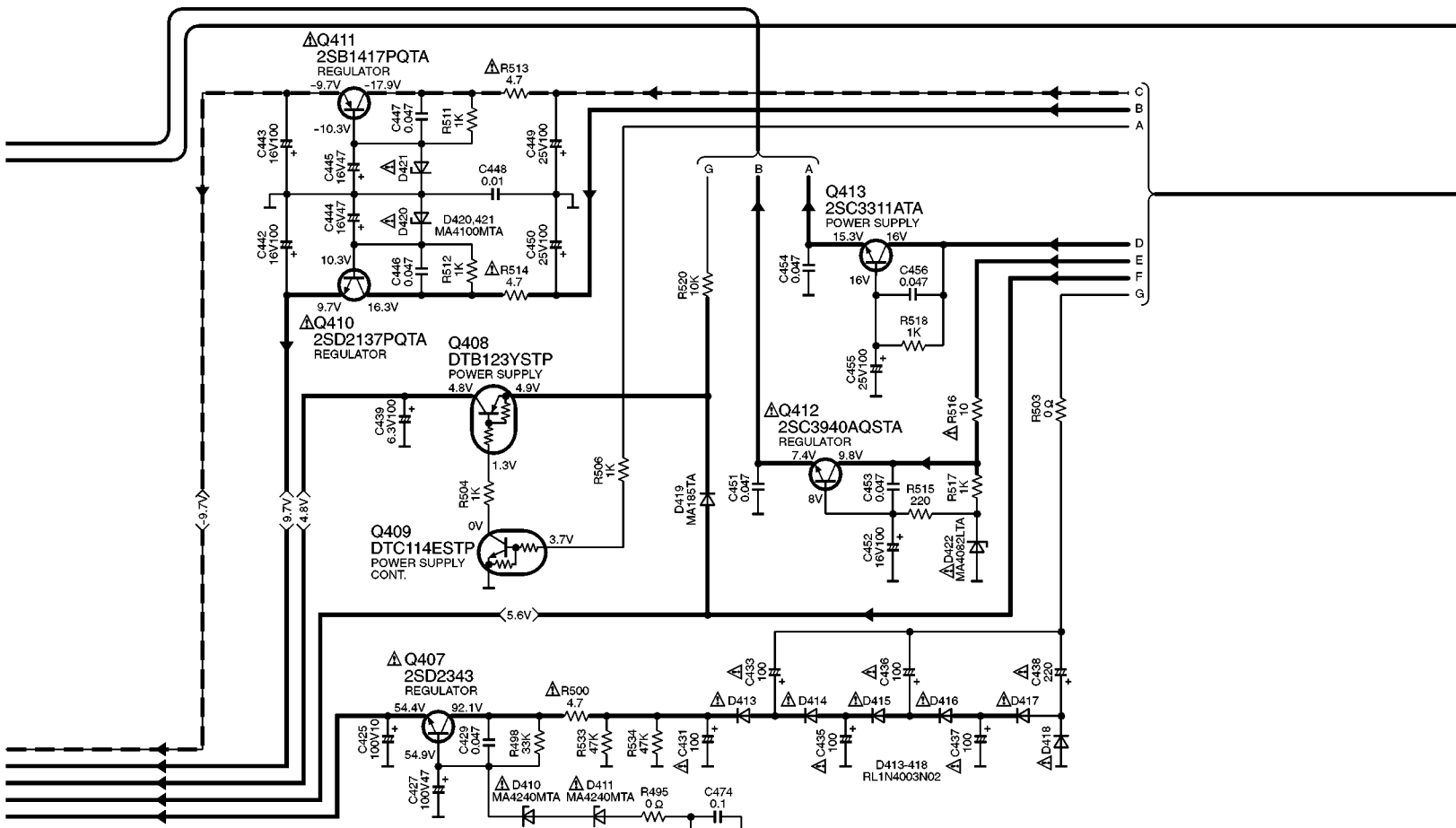

SCHEMATIC DIAGRAM-7



VOLUME CIRCUIT

→ : POSITIVE VOLTAGE LINE    - - - - - : NEGATIVE VOLTAGE LINE

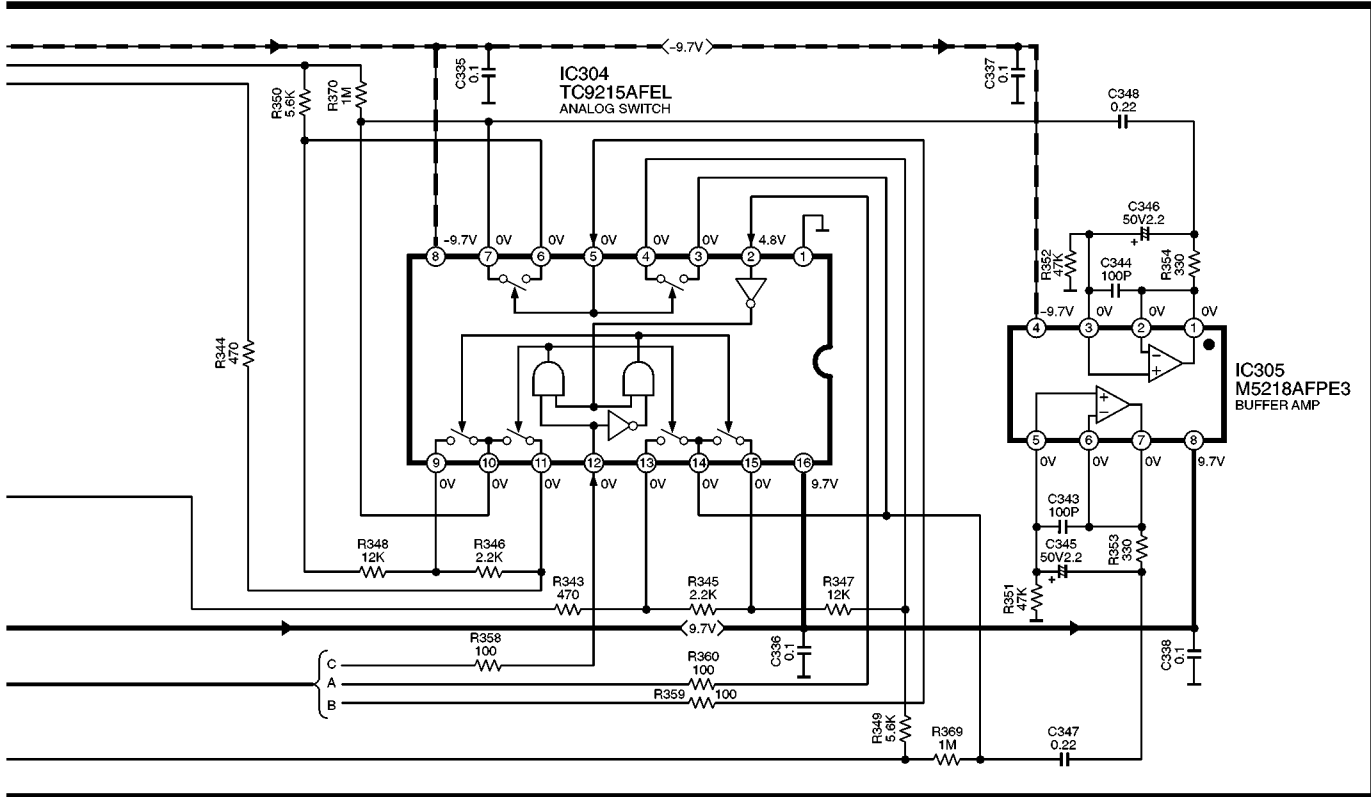

SCHEMATIC DIAGRAM-8

**E** MAIN CIRCUIT

→ : POSITIVE VOLTAGE LINE  
 - - - - - : NEGATIVE VOLTAGE LINE  
 ⇨ : FM/ AM SIGNAL LINE

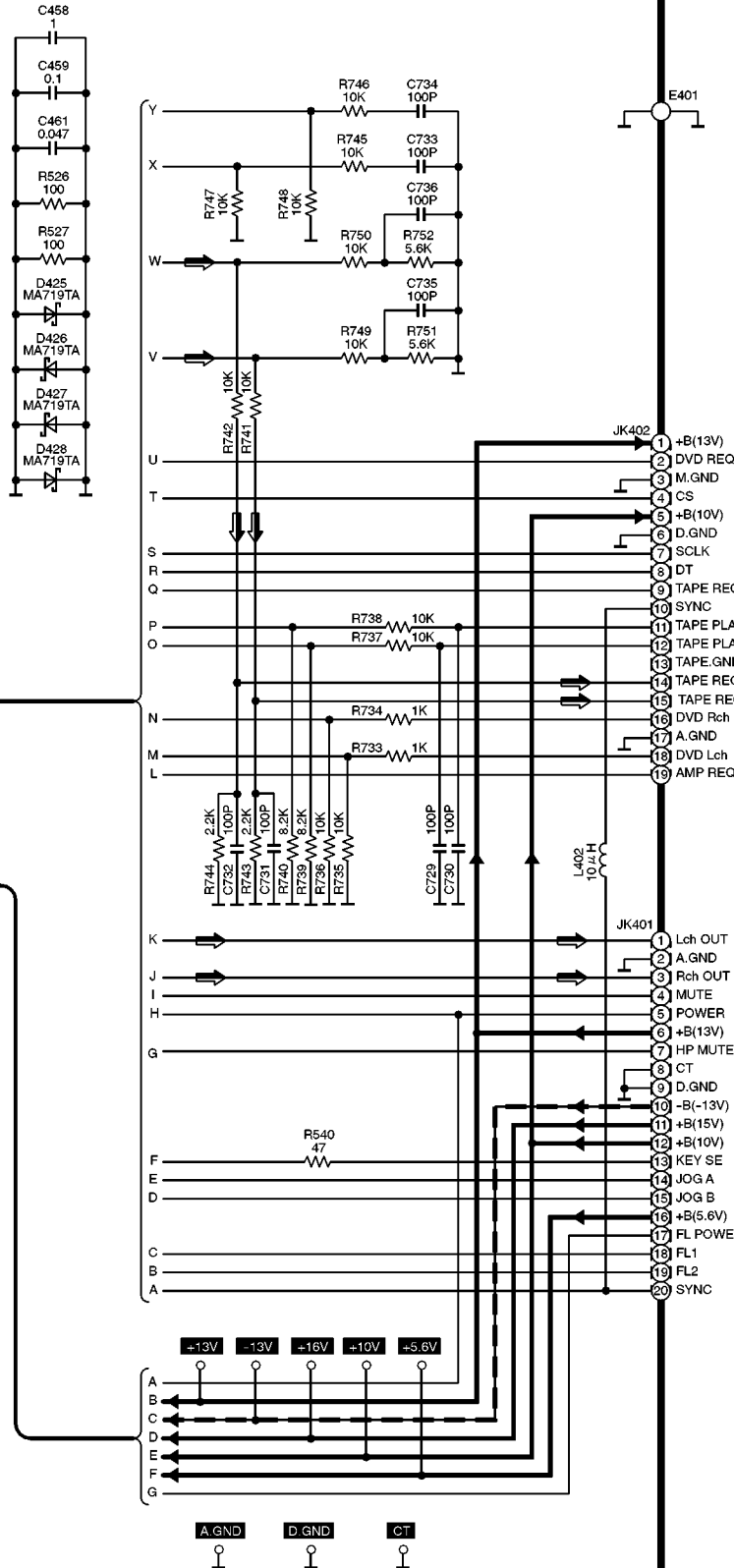

To DVD AUDIO/ VIDEO PLAYER(SL-HDA710) & CASSETTE DECK(RS-HDA710)

To AMPLIFIER (SE-HDA710)



SCHEMATIC DIAGRAM-10

: POSITIVE VOLTAGE LINE  
 : FM SIGNAL LINE  
 : FM AM SIGNAL LINE  
 : AM SIGNAL LINE  
 : AM OSC SIGNAL LINE

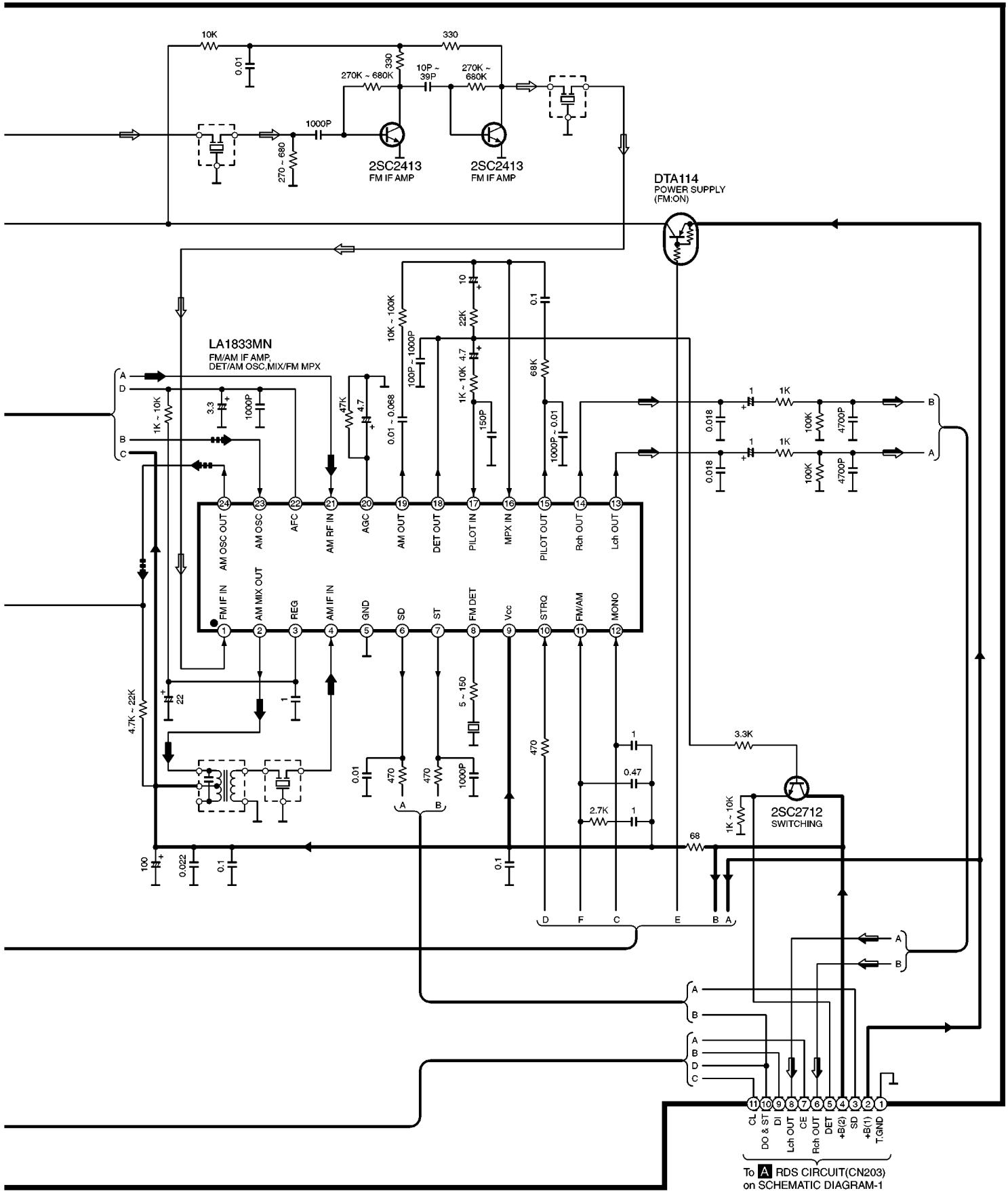

# 10 Printed Circuit Board Diagram

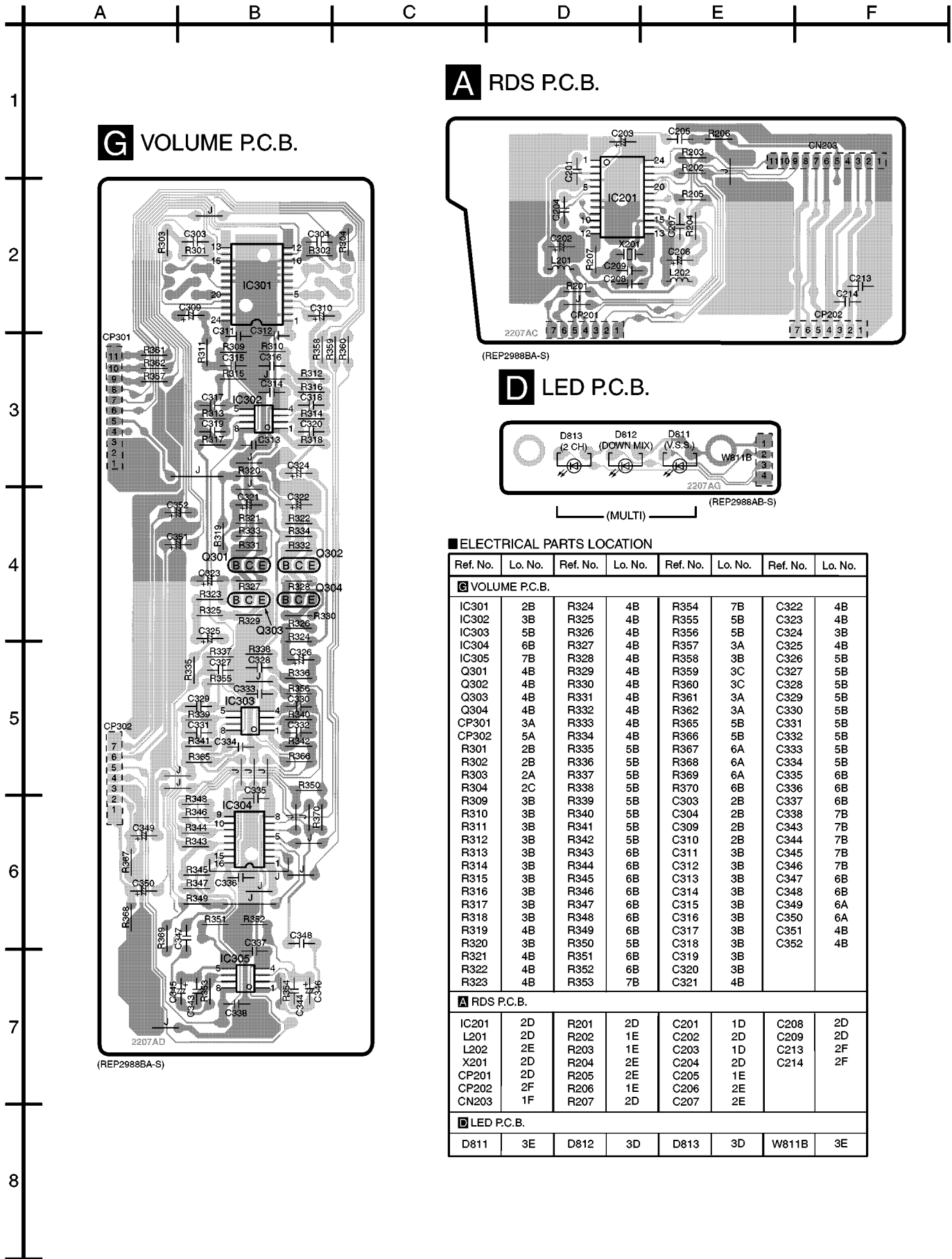

**G** VOLUME P.C.B.

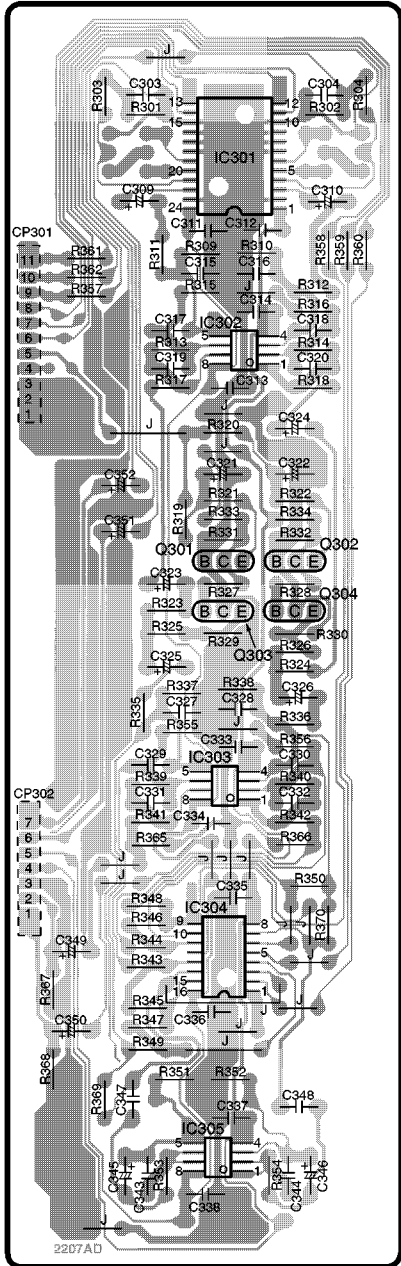

(REP2988BA-S)

**A** RDS P.C.B.

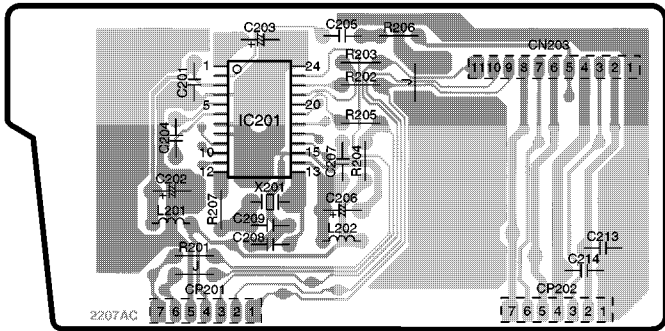

(REP2988BA-S)

**D** LED P.C.B.

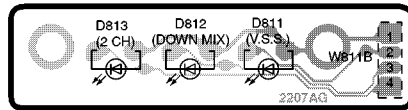

(REP2988AB-S)

**ELECTRICAL PARTS LOCATION**

Ref. No.	Lo. No.	Ref. No.	Lo. No.	Ref. No.	Lo. No.	Ref. No.	Lo. No.
<b>G VOLUME P.C.B.</b>							
IC301	2B	R324	4B	R354	7B	C322	4B
IC302	3B	R325	4B	R355	5B	C323	4B
IC303	5B	R326	4B	R356	5B	C324	3B
IC304	6B	R327	4B	R357	3A	C325	4B
IC305	7B	R328	4B	R358	3B	C326	5B
Q301	4B	R329	4B	R359	3C	C327	5B
Q302	4B	R330	4B	R360	3C	C328	5B
Q303	4B	R331	4B	R361	3A	C329	5B
Q304	4B	R332	4B	R362	3A	C330	5B
CP301	3A	R333	4B	R365	5B	C331	5B
CP302	5A	R334	4B	R366	5B	C332	5B
R301	2B	R335	5B	R367	6A	C333	5B
R302	2B	R336	5B	R368	6A	C334	5B
R303	2A	R337	5B	R369	6A	C335	6B
R304	2C	R338	5B	R370	6B	C336	6B
R309	3B	R339	5B	C303	2B	C337	6B
R310	3B	R340	5B	C304	2B	C338	7B
R311	3B	R341	5B	C309	2B	C343	7B
R312	3B	R342	5B	C310	2B	C344	7B
R313	3B	R343	6B	C311	3B	C345	7B
R314	3B	R344	6B	C312	3B	C346	7B
R315	3B	R345	6B	C313	3B	C347	6B
R316	3B	R346	6B	C314	3B	C348	6B
R317	3B	R347	6B	C315	3B	C349	6A
R318	3B	R348	6B	C316	3B	C350	6A
R319	4B	R349	6B	C317	3B	C351	4B
R320	3B	R350	5B	C318	3B	C352	4B
R321	4B	R351	6B	C319	3B		
R322	4B	R352	6B	C320	3B		
R323	4B	R353	7B	C321	4B		
<b>A RDS P.C.B.</b>							
IC201	2D	R201	2D	C201	1D	C208	2D
L201	2D	R202	1E	C202	2D	C209	2D
L202	2E	R203	1E	C203	1D	C213	2F
X201	2D	R204	2E	C204	2D	C214	2F
CP201	2D	R205	2E	C205	1E		
CP202	2F	R206	1E	C206	2E		
CN203	1F	R207	2D	C207	2E		
<b>D LED P.C.B.</b>							
D811	3E	D812	3D	D813	3D	W811B	3E

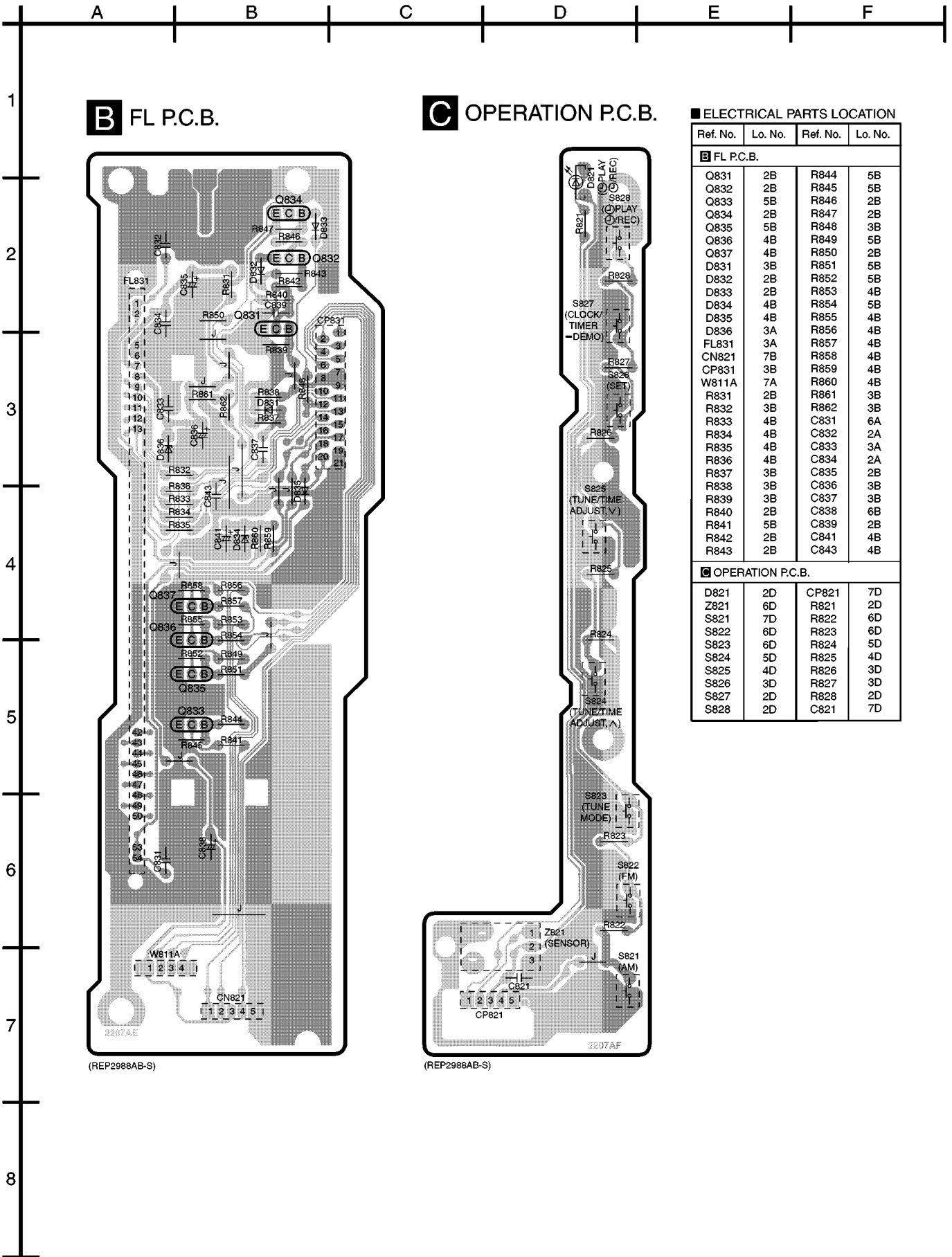

**B** FL P.C.B.

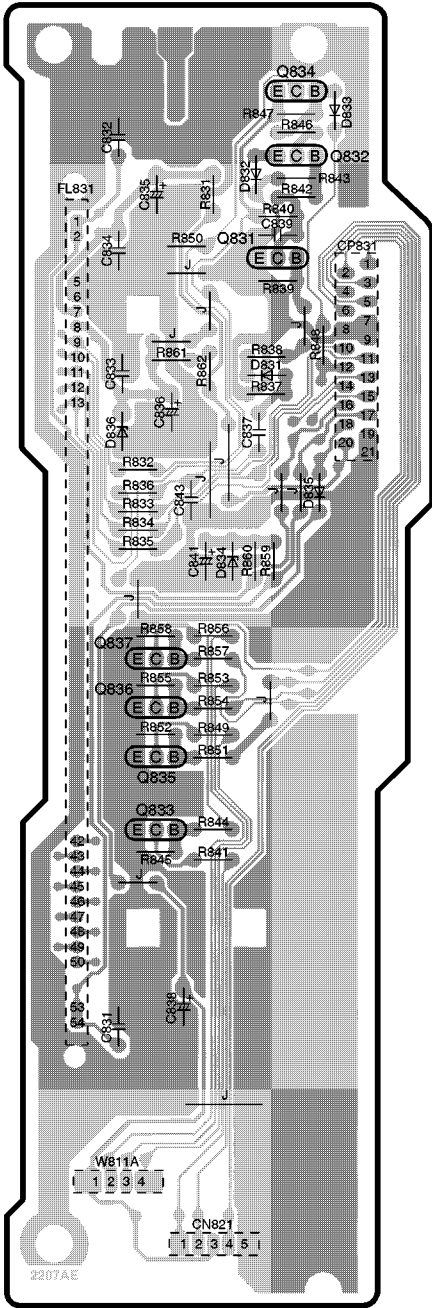

(REP2988AB-S)

**C** OPERATION P.C.B.

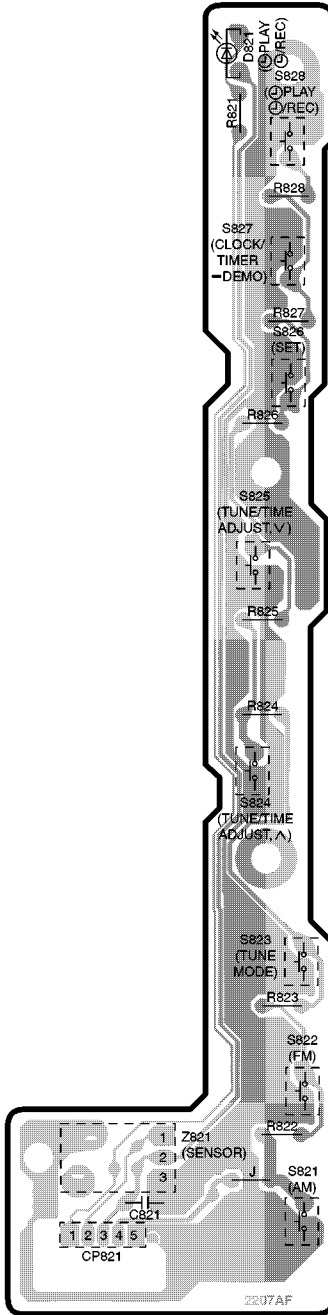

(REP2988AB-S)

**ELECTRICAL PARTS LOCATION**

Ref. No.	Lo. No.	Ref. No.	Lo. No.
<b>B FL P.C.B.</b>			
Q831	2B	R844	5B
Q832	2B	R845	5B
Q833	5B	R846	2B
Q834	2B	R847	2B
Q835	5B	R848	3B
Q836	4B	R849	5B
Q837	4B	R850	2B
D831	3B	R851	5B
D832	2B	R852	5B
D833	2B	R853	4B
D834	4B	R854	5B
D835	4B	R855	4B
D836	3A	R856	4B
FL831	3A	R857	4B
CN821	7B	R858	4B
CP831	3B	R859	4B
W811A	7A	R860	4B
R831	2B	R861	3B
R832	3B	R862	3B
R833	4B	C831	6A
R834	4B	C832	2A
R835	4B	C833	3A
R836	4B	C834	2A
R837	3B	C835	2B
R838	3B	C836	3B
R839	3B	C837	3B
R840	2B	C838	6B
R841	5B	C839	2B
R842	2B	C841	4B
R843	2B	C843	4B
<b>C OPERATION P.C.B.</b>			
D821	2D	CP821	7D
Z821	6D	R821	2D
S821	7D	R822	6D
S822	6D	R823	6D
S823	6D	R824	5D
S824	5D	R825	4D
S825	4D	R826	3D
S826	3D	R827	3D
S827	2D	R828	2D
S828	2D	C821	7D

# E MAIN P.C.B.

To AMPLIFIER

A.GND

To DVD AUDIO/VIDEO  
PLAYER &  
CASSETTE DECK

+10V  
CT  
-13V  
D.GND

+16V  
+13V

+5.6V

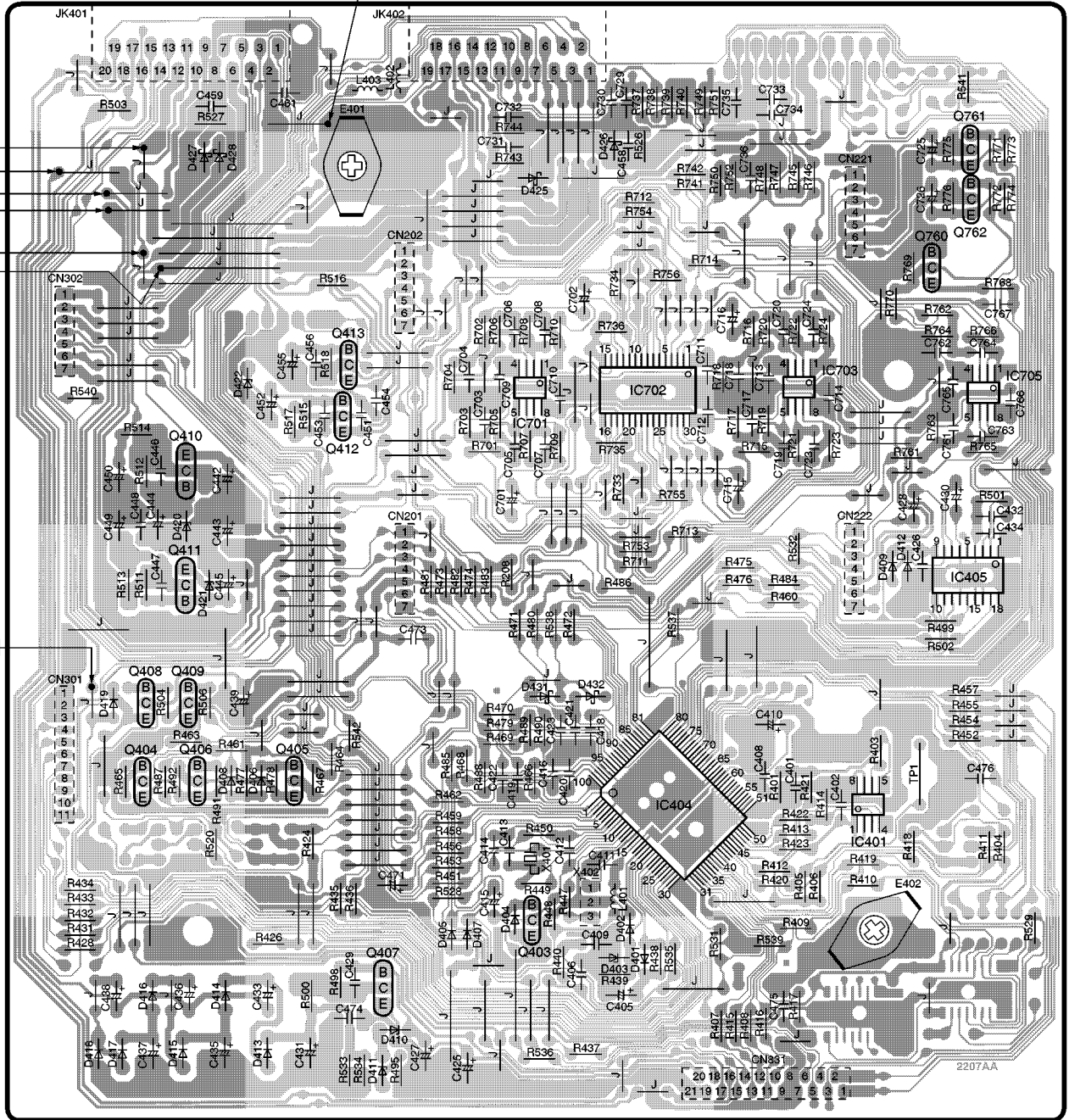

(REP2988BA-S)

2207AA



G | H | I | J | K | L

■ ELECTRICAL PARTS LOCATION

Ref. No.	Lo. No.	Ref. No.	Lo. No.	Ref. No.	Lo. No.	Ref. No.	Lo. No.	Ref. No.	Lo. No.	Ref. No.	Lo. No.
<b>■ MAIN P.C.B.</b>											
IC401	6E	CN222	4E	R459	6C	R532	4E	R755	4D	C448	4B
IC404	6D	CN301	5A	R460	4E	R533	7C	R756	3D	C449	4A
IC405	4F	CN302	3A	R461	5B	R534	7C	R761	4F	C450	4A
IC701	3D	CN831	7E	R462	6C	R535	6D	R762	3F	C451	3C
IC702	3D	JK401	2B	R463	5B	R536	7D	R763	4F	C452	3B
IC703	3E	JK402	2C	R464	5C	R537	5D	R764	3F	C453	3C
IC705	3F	E401	2C	R465	5A	R538	5D	R765	4F	C454	3C
Q403	6D	E402	6E	R466	5D	R539	6E	R766	3F	C455	3B
Q404	5B	TP1	5F	R467	5C	R540	3A	R768	3F	C456	3C
Q405	5B	R208	4D	R468	5C	R541	2F	R769	3F	C458	2D
Q406	5B	R401	5E	R469	5C	R542	5C	R770	3F	C459	2B
Q407	6C	R403	5F	R470	5C	R701	4C	R771	2F	C461	2B
Q408	5B	R404	6F	R471	5D	R702	3C	R772	2F	C471	6C
Q409	5B	R405	6E	R472	5D	R703	3C	R773	2F	C473	5C
Q410	4B	R406	6E	R473	4C	R704	3C	R774	2F	C474	7C
Q411	4B	R407	7E	R474	4C	R705	3C	R775	2F	C475	7E
Q412	3C	R408	7E	R475	4E	R706	3C	R776	2F	C476	5F
Q413	3C	R409	6E	R476	4E	R707	4D	C401	5E	C701	4D
Q760	3F	R410	6E	R477	5B	R708	3D	C402	6E	C702	3D
Q761	2F	R411	6F	R478	5B	R709	4D	C405	7D	C703	3C
Q762	2F	R412	6E	R479	5C	R710	3D	C406	6D	C704	3C
D401	6D	R413	6E	R480	5D	R711	4D	C408	5E	C705	4D
D402	6D	R414	6E	R481	4C	R712	2D	C409	6D	C706	3D
D403	6D	R415	7E	R482	4C	R713	4D	C410	5E	C707	4D
D404	6D	R416	7E	R483	4C	R714	3E	C411	6D	C708	3D
D405	6C	R417	7E	R484	4E	R715	4E	C412	6D	C709	3C
D406	5B	R418	6F	R485	5C	R716	3E	C413	6D	C710	3D
D407	6C	R419	6E	R486	4D	R717	3E	C414	6C	C711	3E
D408	5B	R420	6E	R487	5B	R718	3E	C415	6C	C712	3E
D409	4F	R421	5E	R488	5C	R719	3E	C416	5D	C713	3E
D410	7C	R422	6E	R489	5D	R720	3E	C418	5D	C714	3E
D411	7C	R423	6E	R490	5D	R721	4E	C419	5D	C715	4E
D412	4F	R424	6B	R491	5B	R722	3E	C420	5D	C716	3E
D413	7B	R426	6B	R492	5B	R723	4E	C421	5D	C717	3E
D414	7B	R428	6A	R495	7C	R724	3E	C422	5D	C718	3E
D415	7B	R431	6A	R498	6C	R733	4D	C423	5D	C719	4E
D416	7B	R432	6A	R499	5F	R734	3D	C425	7C	C720	3E
D417	7A	R433	6A	R500	7B	R735	4D	C426	4F	C723	4E
D418	7A	R434	6A	R501	4F	R736	3D	C427	7C	C724	3E
D419	5A	R435	6C	R502	5F	R737	2D	C428	4F	C725	2F
D420	4B	R436	6C	R503	2A	R738	2D	C429	6C	C726	2F
D421	4B	R437	7D	R504	5B	R739	2D	C430	4F	C729	2D
D422	3B	R438	6D	R506	5B	R740	2D	C431	7B	C730	2D
D425	2D	R439	6D	R511	4B	R741	2E	C432	4F	C731	2D
D426	2D	R440	6D	R512	4B	R742	2E	C433	7B	C732	2D
D427	2B	R447	6D	R513	4B	R743	2D	C434	4F	C733	2E
D428	2B	R448	6D	R514	4B	R744	2D	C435	7B	C734	2E
D431	5D	R449	6D	R515	3B	R745	2E	C436	7B	C735	2E
D432	5D	R450	6D	R516	3B	R746	2E	C437	7B	C736	2E
L401	6D	R451	6C	R517	3B	R747	2E	C438	7A	C761	4F
L402	2C	R452	5F	R518	3B	R748	2E	C439	5B	C762	3F
L403	2C	R453	6C	R520	6B	R749	2E	C442	4B	C763	4F
X401	6D	R454	5F	R526	2D	R750	2E	C443	4B	C764	3F
X402	6D	R455	5F	R527	2B	R751	2E	C444	4B	C765	3F
CN201	4C	R456	6C	R528	6C	R752	2E	C445	4B	C766	3F
CN202	3C	R457	5F	R529	6F	R753	4D	C446	4B	C767	3F
CN221	2E	R458	6C	R531	6E	R754	2D	C447	4B		
<b>■ IN/OUT TERMINAL P.C.B.</b>											
IC221	5K	R223	2K	R237	4K	R253	3L	C232	5K	C246	4K
IC222	4K	R224	2K	R238	4K	R254	4L	C233	5K	C247	4K
IC223	3K	R225	2L	R239	4K	R255	2K	C234	5K	C248	4K
D231	5K	R226	2K	R240	4K	R256	2K	C235	4K	C249	4K
D232	5K	R227	2K	R241	4K	R262	3K	C236	4K	C250	4K
L221	2K	R228	2K	R242	4K	C221	2K	C237	4K	C251	3K
L222	2K	R229	2K	R243	4K	C222	2J	C238	4K	C252	3K
L231	4K	R230	2J	R244	4K	C223	2K	C239	5K	C253	3K
L232	4K	R231	5K	R245	4K	C224	2K	C240	5K	C254	3K
CP221	3L	R232	5K	R246	4K	C225	2K	C241	4K		
CP222	5L	R233	5K	R249	3K	C226	2K	C242	4K		
JK221	2K	R234	5K	R250	3K	C227	2K	C243	4K		
R221	2K	R235	4K	R251	3K	C228	2K	C244	4K		
R222	2J	R236	4K	R252	3K	C231	5K	C245	4K		

**F** IN/OUT TERMINAL P.C.B.

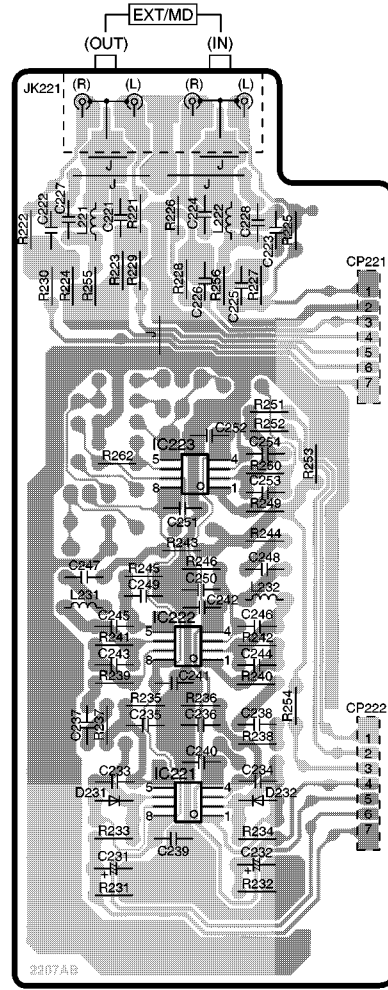

# 11 Terminal Function of IC's

## 11.1. IC404(M30803MG100F): SYSTEM CONTROL/FL DRIVE

Pin No.	Mark	I/O Division	Function
1	P96/TX D4/CTX0	O	DVD, Tape, Amp. communication data output terminal
2	P95/CLK4 /CRX0	I	DVD, Tape, Amp. communication clock input terminal
3	P94	O	Amp. communication request output terminal
4	P93	O	Tape communication request output terminal
5	P92	—	Not used, connected to GND
6	P91	I	DVD, Tape, Amp. communication signal input terminal
7	P90	O	DVD communication request signal output terminal
8	BYTE	—	Not used, connected to GND
9	CNVSS	—	Connected to GND
10	P98/XCIN	I	Crystal oscillator input terminal (f=32.768 kHz)
11	P86/XCOUT	O	Crystal oscillator output terminal (f=32.768 kHz)
12	RESET	I	Reset signal input terminal
13	XOUT	O	Ceramic oscillator output terminal (f=20 MHz)
14	VSS	—	Connected to GND
15	XIN	I	Ceramic oscillator output terminal (f=20 MHz)
16	VCC	I	Power supply input terminal
17	P85/MN1	—	Not used, open
18	P84/INT2	I	Power failure detection input terminal
19	P83	O	CR timer output terminal for clock back up
20	P82/INT0	I	Remote controller signal input terminal
21	P81	O	Muting signal output terminal ("L" : OFF, "H" : ON)
22	P80	O	Power output terminal ("L" : OFF, "H" : ON)
23	P77	O	Chip enable output terminal for TC9412
24	P76	O	BLFS1 output terminal
25	P75	O	BLFS2 output terminal
26	P74	O	BLFS3 output terminal
27	P73	O	Mute-R signal output terminal ("L" : OFF, "H" : ON)
28	P72	O	Mute-L signal output terminal ("L" : OFF, "H" : ON)
29	P71/RXD2	I	PMD communication data input terminal
30	P70/TXD2	O	PMD communication data output terminal
31	P67/TXD1	O	COG-VFD data output terminal
32	P66	O	COG-VFD blank output terminal ("L" : blank)
33	P65/CLK1	O	COG-VFD clock output terminal
34	P64	O	COG-VFD latch output terminal ("L" : latch)
35	P63/TXD0	O	MD communication data output terminal
36	P62/RXD0	I	MD communication data input terminal
37	P61/CLK0	O	MD communication clock output terminal
38	P60	I	MD communication input terminal
39	P57	—	Not used, open
40	P56	O	MD communication in/out select output terminal ("L" : input, "H" : output)

Pin No.	Mark	I/O Division	Function
41	P55	—	Connected to GND
42	P54	O	MD communication request output terminal
43	P53/CLKOUT	I/O	Clock checking in/output terminal
44	P52	I	MD loading SW input terminal
45	P51	I/O	Data in/output terminal for IC401
46	P50/WRL/WR/CASL	I	Connected to power supply through resistor
47	P47/CS0 /A23	O	Clock output terminal for IC401
48	P46/CS1 /A22	O	Chip enable output terminal for IC401
49	P45/CS2 /A21	—	Connected to GND
50	P44/CS3 /A20		
51	P43/A19		
52	P42		
53	P41		
54	—		
55	—		
56	—		
57	—		
58	—		
59	—		
60	—		
61	—		
62	VCC	—	Connected to GND through capacitor
63	P30/A8	I	Connected to GND
64	VSS	—	Connected to GND
65	P27	—	Not used, open
66	P26	—	
67	P25	—	
68	P24	—	
69	P23	I	Connected to GND
70	P22	—	Not used, open
71	P21	I	Connected to GND
72	P20	—	Not used, open
73	P17	—	Not used, open
74	P16	O	LED drive signal output terminal ("L" : OFF, "H" : ON)
75	P15		
76	P14		
77	P13		
78	P12	—	
79	P11	O	Mute signal output terminal ("L" : OFF, "H" : ON)
80	P10	O	Chip enable output terminal for IC702
81	P07/D7	O	Data output terminal for IC405
82	P06/D6		
83	P05		
84	P04	I	Signal detection input terminal
85	P03	O	Chip enable output terminal
86	P02	I	Data input terminal
87	P01	O	Data input terminal
88	P00	O	Clock input terminal
89	P107/AN7	I	Power supply input terminal for IC405
90	P106/AN6	I	30 kHz BPF power supply input terminal
91	P105/AN5	I	70 kHz BPF power supply input terminal
92	P104/AN4	I	Headphone SW input terminal ("L" : ON)

Pin No.	Mark	I/O Division	Function
93	P103/AN3	I	VOLUME JOG input terminal
94	P102/AN2		
95	P101/AN1	I	Key input terminal for amplifier
96	AVSS	—	Connected to GND
97	P100/AN0	—	Key input terminal for tuner
98	VREF	I	Power supply input terminal
99	AVCC		
100	P97/RXD4	I	DVD, TAPE communication data input terminal

# 12 Replacement Parts List

## Note:

\*Important safety notice:

Components identified by  $\Delta$  mark have special characteristics important for safety.

Furthermore, special parts which have purposes of fireretardant (resistors), high-quality sound (capacitors), lownoise (resistors), etc. are used.

When replacing any of components, be sure to use only manufacture's specified parts shown in the parts list.

\*The markings <RTL> indicate that the Retention Time is limited for these items. After the discontinuation of these assemblies in production, the items will continue to be available for a specific period of time. The retentionperiod of availability is dependant on the type of assembly, and in accordance with the laws governing part and product retention. After the end of this period, the assembly will no longer be available.

\*Capacity values are in microfarads ( $\mu$ F) unless specified otherwise, P=Pico-farads (pF) F=Farads (F)

\*Resistance values are in ohms, unless specified otherwise, 1K=1,000 (OHM), 1M=1,000K (OHM)

Ref. No.	Part No.	Part Name & Description	Pcs	Remarks
1	RHD30007-S	SCREW	4	
2	RKM0413-N	CABINET	1	
3	XTB3+8JFZ	SCREW	1	
4	RAN0004MM-1	TUNER UNIT (Z101)	1	
7	RKA0114-K	FOOT	4	
7-1	RKA0083-K	CUSHION	4	
8	XTB3+5JFZ	SCREW	4	
9	RGG0174C-N	FRONT PANEL	1	
10	RGF0775-N	SUB PANEL	1	
11	RGU1843-N	BUTTON, TUNE/TIME ADJUST	1	
12	RGU1857-N	BUTTON, FM/AM/TUNE MODE	1	
13	RKW0600A-N	WINDOW	1	
14	XTBS26+8J	SCREW	13	
15	XTBS3+8JFZ1	SCREW	9	
16	XTB3+12JFZ	SCREW	3	
17	RGL0481-Q	TIMER INDICATOR	1	
18	RGL0493-Q	LIGHT GUIDE	1	
C211,12	ECBT1C332KR5	16V 3300P	2	
C213,14	ECBT1H473KB5	50V 0.047U	2	
C221,26	ECBT1H101KB5	50V 100P	6	F1D1H101A012
C227,28	ECBT1H102KB5	50V 1000P	2	F1D1H102A012
C231,32	ECA1CAK100XB	16V 10U	2	
C233,34	ECBT1H101KB5	50V 100P	2	F1D1H101A012
C235,36	ECBT1H331KB5	50V 330P	2	F1D1H331A012
C237,38	ECBT1H103KB5	50V 0.01U	2	
C239-42	ECBT1H104ZF5	50V 0.1U	4	F1E1H104A001
C243,44	ECBT1H100J5	50V 10P	2	F1D1H100A006
C245,46	ECBT1H101KB5	50V 100P	2	F1D1H101A012
C247	ECBT1C822MS5	16V 8200P	1	F1D1C822A004
C248	ECBT1C152KR5	16V 1500P	1	
C249,50	ECBT1H331KB5	50V 330P	2	F1D1H331A012
C251,52	ECBT1H104ZF5	50V 0.1U	2	F1E1H104A001
C253	ECBT1H330J5	50V 33P	1	F1D1H330A006
C254	ECBT1H101KB5	50V 100P	1	F1D1H101A012
C303,04	ECBT1H330J5	50V 33P	2	F1D1H330A006
C309,10	ECA1CAK100XB	16V 10U	2	
C311-14	ECBT1H104ZF5	50V 0.1U	4	F1E1H104A001
C315,16	ECBT1H330J5	50V 33P	2	F1D1H330A006
C317,18	ECBT1H101KB5	50V 100P	2	F1D1H101A012
C319,20	ECBT1H330J5	50V 33P	2	F1D1H330A006

Ref. No.	Part No.	Part Name & Description	Pcs	Remarks
C321,22	ECA1CAK470XB	16V 47U	2	
C323-26	ECA1CAK100XB	16V 10U	4	
C327,28	ECBT1H330J5	50V 33P	2	F1D1H330A006
C329,30	ECBT1H101KB5	50V 100P	2	F1D1H101A012
C331,32	ECBT1H330J5	50V 33P	2	F1D1H330A006
C333-38	ECBT1H104ZF5	50V 0.1U	6	F1E1H104A001
C343,44	ECBT1H101KB5	50V 100P	2	F1D1H101A012
C345,46	ECEA1HKS2R2	50V 2.2U	2	
C347,48	ECQV1H224JL3	50V 0.22U	2	
C349-52	ECA1CAK100XB	16V 10U	4	
C401	ECBT1H101KB5	50V 100P	1	F1D1H101A012
C402	ECBT1H104ZF5	50V 0.1U	1	F1E1H104A001
C405	ECA1CAK100XB	16V 10U	1	
C406	ECBT1H102KB5	50V 1000P	1	F1D1H102A012
C408	ECBT1H104ZF5	50V 0.1U	1	F1E1H104A001
C409	ECBALE103ZF5	25V 0.01U	1	ECBT1E103ZF5
C410	ECA0JM332B	6.3V 3300U	1	
C411,12	ECBT1H104ZF5	50V 0.1U	2	F1E1H104A001
C413	ECBT1H180J5	50V 18P	1	F1D1H180A006
C414	ECBT1H220J5	50V 22P	1	F1D1H220A006
C415	RCE1HKA3R3BG	50V 3.3U	1	F2A1H3R3A015
C416	ECBT1H104ZF5	50V 0.1U	1	F1E1H104A001
C418	ECBT1H102KB5	50V 1000P	1	F1D1H102A012
C419	ECBT1H104KB5	50V 0.1U	1	
C420	ECBT1H104ZF5	50V 0.1U	1	F1E1H104A001
C421	ECBT1H102KB5	50V 1000P	1	F1D1H102A012
C422	ECBT1H104KB5	50V 0.1U	1	
C423	ECBT1H102KB5	50V 1000P	1	F1D1H102A012
C425	ECA2AM100	100V 10U	1	
C426	ECBT1H104ZF5	50V 0.1U	1	F1E1H104A001
C427	ECA2AM470	100V 47U	1	
C428	ECEA1HKS010	50V 1U	1	
C429	ECBT1H473KB5	50V 0.047U	1	
C430	ECEA1HKS010	50V 1U	1	
C431	ECA2AM101	100U	1	$\Delta$
C432	ECBT1H104ZF5	50V 0.1U	1	F1E1H104A001
C433	ECA2AM101	100U	1	$\Delta$
C434	ECBT1H104ZF5	50V 0.1U	1	F1E1H104A001
C435	ECA2AM101	100U	1	$\Delta$
C436	ECA1HM101	100U	1	$\Delta$
C437	ECA1VM101	100U	1	$\Delta$
C438	ECA1EM221	220UF	1	$\Delta$
C439	ECEA0JKS101	6.3V 100U	1	
C442,43	ECA1CAK101XB	16V 100U	2	
C444,45	ECA1CAK470XB	16V 47U	2	
C446,47	ECBT1H473KB5	50V 0.047U	2	
C448	ECBALE103ZF5	25V 0.01U	1	ECBT1E103ZF5
C449,50	ECA1EAM101XB	25V 100U	2	
C451	ECBT1H473KB5	50V 0.047U	1	
C452	ECA1CAK101XB	16V 100U	1	
C453,54	ECBT1H473KB5	50V 0.047U	2	
C455	ECA1EAM101XB	25V 100U	1	
C456	ECBT1H473KB5	50V 0.047U	1	
C458	ECBT1C105ZF5	16V 1U	1	F1E1C1050001
C459	ECBT1H104ZF5	50V 0.1U	1	F1E1H104A001
C461	ECBT1H473KB5	50V 0.047U	1	
C471	ECA1HAK010XI	50V 1U	1	ECA1HAK010XB
C473	ECBT1H102KB5	50V 1000P	1	F1D1H102A012
C474,75	ECBT1H104KB5	50V 0.1U	2	
C476	ECBT1H102KB5	50V 1000P	1	F1D1H102A012
C701,02	ECA1CAK100XB	16V 10U	2	
C703,04	ECBT1H330J5	50V 33P	2	F1D1H330A006
C705,06	ECBT1H101KB5	50V 100P	2	F1D1H101A012
C707,08	ECBT1H330J5	50V 33P	2	F1D1H330A006
C709-14	ECBT1H104ZF5	50V 0.1U	6	F1E1H104A001
C715,16	ECA1CAK100XB	16V 10U	2	
C717,18	ECBT1H331KB5	50V 330P	2	F1D1H331A012
C719,20	ECBT1H101KB5	50V 100P	2	F1D1H101A012
C723,24	ECBT1H101KB5	50V 100P	2	F1D1H101A012
C725,26	ECA1CAK100XB	16V 10U	2	
C729-36	ECBT1H101KB5	50V 100P	8	F1D1H101A012
C761,62	ECBT1H331KB5	50V 330P	2	F1D1H331A012
C763,64	ECBT1H101KB5	50V 100P	2	F1D1H101A012

Ref. No.	Part No.	Part Name & Description	Pcs	Remarks
C765,66	ECBT1H104ZF5	50V 0.1U	2	F1E1H104A001
C767	ECBT1H473KB5	50V 0.047U	1	
C821	ECBT1H104ZF5	50V 0.1U	1	F1E1H104A001
C831-33	ECBT1H104ZF5	50V 0.1U	3	F1E1H104A001
C834	ECQV1J103JM3	6.3V 0.01U	1	
C835,36	RCE2AU330BG	100V 33U	2	F2A2A3300006
C837	ECBT1H104KB5	50V 0.1U	1	
C838	ECEA0JKS470	6.3V 47UF	1	
C839	ECBT1H103KB5	50V 0.01U	1	
C841	ECEA0JKS470	6.3V 47UF	1	
C843	ECBT1H101KB5	50V 100P	1	F1D1H101A012
CN201,02	RJT100W07	CONNECTOR (7P)	2	K1KA07A00082
CN203	RJT100W11	CONNECTOR (11P)	1	
CN221,22	RJT100W07	CONNECTOR (7P)	2	K1KA07A00082
CN301	RJT100W11	CONNECTOR (11P)	1	
CN302	RJT100W07	CONNECTOR (7P)	1	K1KA07A00082
CN821	RJT066H05A	CONNECTOR (5P)	1	K1KA05B00073
CN831	RJS1A6821	CONNECTOR (21P)	1	K1MN21A00011
CP201,02	RJU100W07	CONNECTOR (7P)	2	K1KB07A00018
CP221,22	RJU100W07	CONNECTOR (7P)	2	K1KB07A00018
CP301	RJU100W11	CONNECTOR (11P)	1	
CP302	RJU100W07	CONNECTOR (7P)	1	K1KB07A00018
CP821	RJU066H05	CONNECTOR (5P)	1	K1KB05C00003
CP831	RJS1A6221-1	CONNECTOR (21P)	1	K1MN21C00001
D231,32	MA165	DIODE	2	MA2C165
D401	MA165	DIODE	1	MA2C165
D402	1SS291TA	DIODE	1	
D403	MA4051M	DIODE	1	MAZ40510M
D404-06	MA165	DIODE	3	MA2C165
D407	1SS291TA	DIODE	1	
D408	MA165	DIODE	1	MA2C165
D409	MA719TA	DIODE	1	MA2C71900A
D410,11	MA4240H	DIODE	2	MAZ42400H △
D412	MA719TA	DIODE	1	MA2C71900A
D413-18	RL1N4003N02	DIODE	6	△
D419	MA185TA	DIODE	1	MA2C18500E
D420,21	MA4100M	DIODE	2	MAZ41000M △
D422	MA4082LTA	DIODE	1	MAZ40820LF △
D425-28	MA719TA	DIODE	4	MA2C71900A
D431,32	MA719TA	DIODE	2	MA2C71900A
D811-13	SLR325YCT31	LED (YELLOW)	3	
D821	SLR325VCT31	LED	1	
D831-33	MA165	DIODE	3	MA2C165
D834	MA4051M	DIODE	1	MAZ40510M
D835	MA165	DIODE	1	MA2C165
D836	MA4051M	DIODE	1	MAZ40510M
FL831	RSL0300-F	FL	1	
IC221	NJM4580MTE1	IC	1	C0ABBB000127
IC222	NJM2114M-T1	IC	1	C0ABBB000178
IC223	M5218AFPE3	IC	1	C0ABBB000163
IC301	TC9412AF	IC	1	C1BB00000350
IC302,03	NJM4580EDTE1	IC	2	C0ABBB000125
IC304	TC9215AFEL	IC	1	
IC305	M5218AFPE3	IC	1	C0ABBB000163
IC401	BR93LC46FEW2	IC	1	
IC404	M30803MG100F	IC	1	
IC405	BA3834F-E2	IC	1	
IC701	NJM4580EDTE1	IC	1	C0ABBB000125
IC702	NJU7313AMT2	IC	1	C0JZAS000002
IC703	M5218AFPE3	IC	1	C0ABBB000163
IC705	M5218AFPE3	IC	1	C0ABBB000163
JK221	SJF3069-20N	JACK, EXT OUT/IN	1	
JK401	RJT065K20	SYSTEM CONNECTOR (20P)	1	K1FA220B0006
JK402	RJT065K19	SYSTEM CONNECTOR (19P)	1	K1FA219B0001
L221,22	BL02RN2R62T4	COIL	2	J0JKB0000020
L231,32	ELELN472KA	COIL	2	

Ref. No.	Part No.	Part Name & Description	Pcs	Remarks
L401-03	RLQA100JT-Y	COIL	3	G0C100JA0023
P1	RPG4718	PACKING CASE (TUNER)	1	
P2	RPN1266	CUSHION	1	
P3	SPP740-1	PROTECTION BAG (TUNER)	1	
PCB1	REP2988CA-S	MOTHER P.C.B.	1	(RTL)
PCB2	REP2988BB-S	PANEL P.C.B.	1	(RTL)
Q301,02	DTA114ESTP	TRANSISTOR	2	B1GCCFJA0002
Q303,04	2SD2144STA	TRANSISTOR	2	B1AAGC000006
Q403	UN4214TA	TRANSISTOR	1	UNR421400A
Q404	DTC143XSTP	TRANSISTOR	1	B1GACFGH0002
Q405,06	2SC331LATA	TRANSISTOR	2	2SC3311A0A
Q407	2SD2343	TRANSISTOR	1	△
Q408	DTB123YSTP	TRANSISTOR	1	B1GCGFEJ0001
Q409	DTC114ESTP	TRANSISTOR	1	B1GACFJJ0007
Q410	2SD2137PQTA	TRANSISTOR	1	2SD21370PA △
Q411	2SB1417PQTA	TRANSISTOR	1	2SB14170JA △
Q412	2SC3940AQSTA	TRANSISTOR	1	2SC3940ARA △
Q413	2SC331LATA	TRANSISTOR	1	2SC3311A0A
Q760	DTA114ESTP	TRANSISTOR	1	B1GCCFJA0002
Q761,62	2SD2144STA	TRANSISTOR	2	B1AAGC000006
Q831-33	2SC331LATA	TRANSISTOR	3	2SC3311A0A
Q834	2SA1309ATA	TRANSISTOR	1	2SA1309AWA
Q835-37	2SC331LATA	TRANSISTOR	3	2SC3311A0A
R208	ERDS2FJ153	1/4W 15K	1	
R221,22	ERDS2FJ331	1/4W 330	2	
R223,24	ERDS2FJ473	1/4W 47K	2	
R225,26	ERDS2FJ472	1/4W 4.7K	2	
R227,28	ERDS2FJ123	1/4W 12K	2	
R229,30	ERDS2FJ101	1/4W 100	2	
R231,32	ERDS2FJ103	1/4W 10K	2	
R233,34	ERDS2FJ101	1/4W 100	2	
R235,36	ERDS2FJ473	1/4W 47K	2	
R237,38	ERDS2FJ102	1/4W 1K	2	
R239,40	ERDS2FJ101	1/4W 100	2	
R241	ERDS2FJ472	1/4W 4.7K	1	
R242	ERDS2FJ153	1/4W 15K	1	
R243,44	ERDS2FJ100	1/4W 10	2	
R245,46	ERDS2FJ103	1/4W 10K	2	
R249	ERDS2FJ100	1/4W 10	1	
R250	ERDS2FJ103	1/4W 10K	1	
R251,52	ERDS2FJ223	1/4W 22K	2	
R253	ERDS2FJ103	1/4W 10K	1	
R254	ERDS2FJ473	1/4W 47K	1	
R255,56	ERDS2FJ220	1/4W 22	2	
R262	ERDS2FJ104	1/4W 100K	1	
R301,02	ERDS2FJ104	1/4W 100K	2	
R303,04	ERDS2FJ101	1/4W 100	2	
R309,10	ERDS2FJ473	1/4W 47K	2	
R311,12	ERDS2FJ101	1/4W 100	2	
R313-16	ERDS2FJ472	1/4W 4.7K	4	
R317,18	ERDS2FJ101	1/4W 100	2	
R319,20	ERDS2FJ222	1/4W 2.2K	2	
R321,22	ERDS2FJ102	1/4W 1K	2	
R323,24	ERDS2FJ332	1/4W 3.3K	2	
R325,26	ERDS2T0T	1/4W 0	2	
R327,28	ERDS2FJ102	1/4W 1K	2	
R329,30	ERDS2FJ223	1/4W 22K	2	
R331-34	ERDS2FJ105	1/4W 1M	4	
R335,36	ERDS2FJ103	1/4W 10K	2	
R337,38	ERDS2FJ473	1/4W 47K	2	
R339,40	ERDS2FJ103	1/4W 10K	2	
R341,42	ERDS2FJ102	1/4W 1K	2	
R343,44	ERDS2FJ471	1/4W 470	2	
R345,46	ERDS2FJ222	1/4W 2.2K	2	
R347,48	ERDS2FJ123	1/4W 12K	2	
R349,50	ERDS2FJ562	1/4W 5.6K	2	
R351,52	ERDS2FJ473	1/4W 47K	2	
R353,54	ERDS2FJ331	1/4W 330	2	

Ref. No.	Part No.	Part Name & Description	Pcs	Remarks
R355,56	ERDS2FJ473	1/4W 47K	2	
R357-62	ERDS2FJ101	1/4W 100	6	
R365,66	ERDS2FJ332	1/4W 3.3K	2	
R367,68	ERDS2FJ104	1/4W 100K	2	
R369,70	ERDS2FJ105	1/4W 1M	2	
R401	ERDS2FJ104	1/4W 100K	1	
R403	ERDS2FJ472	1/4W 4.7K	1	
R404	ERDS2FJ473	1/4W 47K	1	
R405,06	ERDS2FJ103	1/4W 10K	2	
R407-13	ERDS2FJ331	1/4W 330	7	
R414	ERDS2FJ223	1/4W 22K	1	
R415-22	ERDS2FJ331	1/4W 330	8	
R423	ERDS2FJ223	1/4W 22K	1	
R424	ERDS2FJ331	1/4W 330	1	
R426	ERDS2FJ331	1/4W 330	1	
R428	ERDS2FJ102	1/4W 1K	1	
R431-34	ERDS2FJ102	1/4W 1K	4	
R435-37	ERDS2FJ331	1/4W 330	3	
R438	ERDS2FJ105	1/4W 1M	1	
R439	ERDS2FJ103	1/4W 10K	1	
R440	ERDS2FJ102	1/4W 1K	1	
R447	ERDS2T0T	1/4W 0	1	
R448	ERDS2FJ104	1/4W 100K	1	
R449	ERDS2FJ103	1/4W 10K	1	
R450	ERDS2FJ102	1/4W 1K	1	
R451-57	ERDS2FJ331	1/4W 330	7	
R458	ERDS2FJ102	1/4W 1K	1	
R459	ERDS2FJ331	1/4W 330	1	
R460	ERDS2FJ102	1/4W 1K	1	
R461	ERDS2FJ103	1/4W 10K	1	
R462	ERDS2FJ331	1/4W 330	1	
R463,64	ERDS2FJ103	1/4W 10K	2	
R465,66	ERDS2FJ331	1/4W 330	2	
R467	ERDS2FJ103	1/4W 10K	1	
R468	ERDS2FJ331	1/4W 330	1	
R469-76	ERDS2FJ102	1/4W 1K	8	
R477	ERDS2FJ223	1/4W 22K	1	
R478	ERDS2FJ103	1/4W 10K	1	
R479-82	ERDS2FJ102	1/4W 1K	4	
R483	ERDS2FJ331	1/4W 330	1	
R484	ERDS2FJ102	1/4W 1K	1	
R485	ERDS2FJ103	1/4W 10K	1	
R486	ERDS2FJ331	1/4W 330	1	
R487	ERDS2FJ472	1/4W 4.7K	1	
R488-90	ERDS2FJ103	1/4W 10K	3	
R491	ERDS2FJ472	1/4W 4.7K	1	
R492	ERDS2FJ473	1/4W 47K	1	
R495	ERDS2T0T	1/4W 0	1	
R498	ERDS2FJ333	1/4W 33K	1	
R499	ERDS2FJ103	1/4W 10K	1	
R500	ERD2FCJ4R7	4.7	1	△
R501	ERDS2FJ104	1/4W 100K	1	
R502	ERDS2FJ101	1/4W 100	1	
R503	ERDS2T0T	1/4W 0	1	
R504	ERDS2FJ102	1/4W 1K	1	
R506	ERDS2FJ102	1/4W 1K	1	
R511,12	ERDS2FJ102	1/4W 1K	2	
R513,14	ERD2FCJ4R7	4.7	2	△
R515	ERDS2FJ221	1/4W 220	1	
R516	ERD2FCG100	10	1	△
R517,18	ERDS2FJ102	1/4W 1K	2	
R520	ERDS2FJ103	1/4W 10K	1	
R526-28	ERDS2FJ101	1/4W 100	3	
R529	ERDS2FJ103	1/4W 10K	1	
R531,32	ERDS2FJ103	1/4W 10K	2	
R533,34	ERDS2FJ473	1/4W 47K	2	
R535	ERDS2FJ332	1/4W 3.3K	1	
R536	ERDS2FJ101	1/4W 100	1	
R537	ERDS2FJ102	1/4W 1K	1	
R538	ERDS2FJ103	1/4W 10K	1	
R539	ERDS2FJ473	1/4W 47K	1	
R540	ERDS2FJ470	1/4W 47	1	
R541	ERDS2FJ101	1/4W 100	1	

Ref. No.	Part No.	Part Name & Description	Pcs	Remarks
R542	ERDS2FJ102	1/4W 1K	1	
R701,02	ERDS2FJ101	1/4W 100	2	
R703,04	ERDS2FJ473	1/4W 47K	2	
R705,06	ERDS2FJ222	1/4W 2.2K	2	
R707,08	ERDS2FJ472	1/4W 4.7K	2	
R709-16	ERDS2FJ101	1/4W 100	8	
R717,18	ERDS2FJ104	1/4W 100K	2	
R719,20	ERDS2FJ102	1/4W 1K	2	
R721,22	ERDS2FJ123	1/4W 12K	2	
R723,24	ERDS2FJ101	1/4W 100	2	
R733,34	ERDS2FJ102	1/4W 1K	2	
R735-38	ERDS2FJ103	1/4W 10K	4	
R740	ERDS2FJ822	1/4W 8.2K	1	
R741,42	ERDS2FJ103	1/4W 10K	2	
R743,44	ERDS2FJ222	1/4W 2.2K	2	
R745-50	ERDS2FJ103	1/4W 10K	6	
R751,52	ERDS2FJ562	1/4W 5.6K	2	
R753,54	ERDS2FJ103	1/4W 10K	2	
R755,56	ERDS2FJ153	1/4W 15K	2	
R761,62	ERDS2FJ102	1/4W 1K	2	
R763,64	ERDS2FJ473	1/4W 47K	2	
R765,66	ERDS2FJ101	1/4W 100	2	
R768	ERDS2FJ102	1/4W 1K	1	
R769,70	ERDS2FJ105	1/4W 1M	2	
R771,72	ERDS2FJ102	1/4W 1K	2	
R773,74	ERDS2FJ182	1/4W 1.8K	2	
R775,76	ERDS2FJ222	1/4W 2.2K	2	
R821	ERDS2FJ221	1/4W 220	1	
R822	ERDS2FJ821	1/4W 820	1	
R823	ERDS2FJ102	1/4W 1K	1	
R824	ERDS2FJ122	1/4W 1.2K	1	
R825	ERDS2FJ152	1/4W 1.5K	1	
R826	ERDS2FJ182	1/4W 1.8K	1	
R827	ERDS2FJ222	1/4W 2.2K	1	
R828	ERDS2FJ332	1/4W 3.3K	1	
R831	ERD2FCG220	22	1	△
R832,33	ERDS2FJ681	1/4W 680	2	
R834	ERDS2FJ101	1/4W 100	1	
R835	ERDS2FJ681	1/4W 680	1	
R836	ERDS2FJ101	1/4W 100	1	
R837	ERDS2FJ104	1/4W 100K	1	
R838	ERDS2FJ103	1/4W 10K	1	
R839,40	ERDS2FJ473	1/4W 47K	2	
R841	ERDS2FJ821	1/4W 820	1	
R842,43	ERDS2FJ473	1/4W 47K	2	
R844	ERDS2FJ102	1/4W 1K	1	
R845-48	ERDS2FJ103	1/4W 10K	4	
R849	ERDS2FJ221	1/4W 220	1	
R850	ERDS2FJ103	1/4W 10K	1	
R851	ERDS2FJ102	1/4W 1K	1	
R852	ERDS2FJ103	1/4W 10K	1	
R853	ERDS2FJ221	1/4W 220	1	
R854	ERDS2FJ102	1/4W 1K	1	
R855	ERDS2FJ103	1/4W 10K	1	
R856	ERDS2FJ221	1/4W 220	1	
R857	ERDS2FJ102	1/4W 1K	1	
R858	ERDS2FJ103	1/4W 10K	1	
R859,60	ERDS2FJ151	1/4W 150	2	
R861,62	ERDS2FJ682	1/4W 6.8K	2	
S821-28	EVQ11G05R	SW, PUSH	8	
W811A	REX1052Y	4PWIRE	1	
X401	RSXD32K7S05	OSCILLATOR	1	H0A327200029
X402	RSXY20M0M01T	OSCILLATOR	1	H2B200500003
Z821	RCDGP1U26XD	REMOTE SENSOR	1	B3RAD0000010

# 13 Cabinet Parts Location

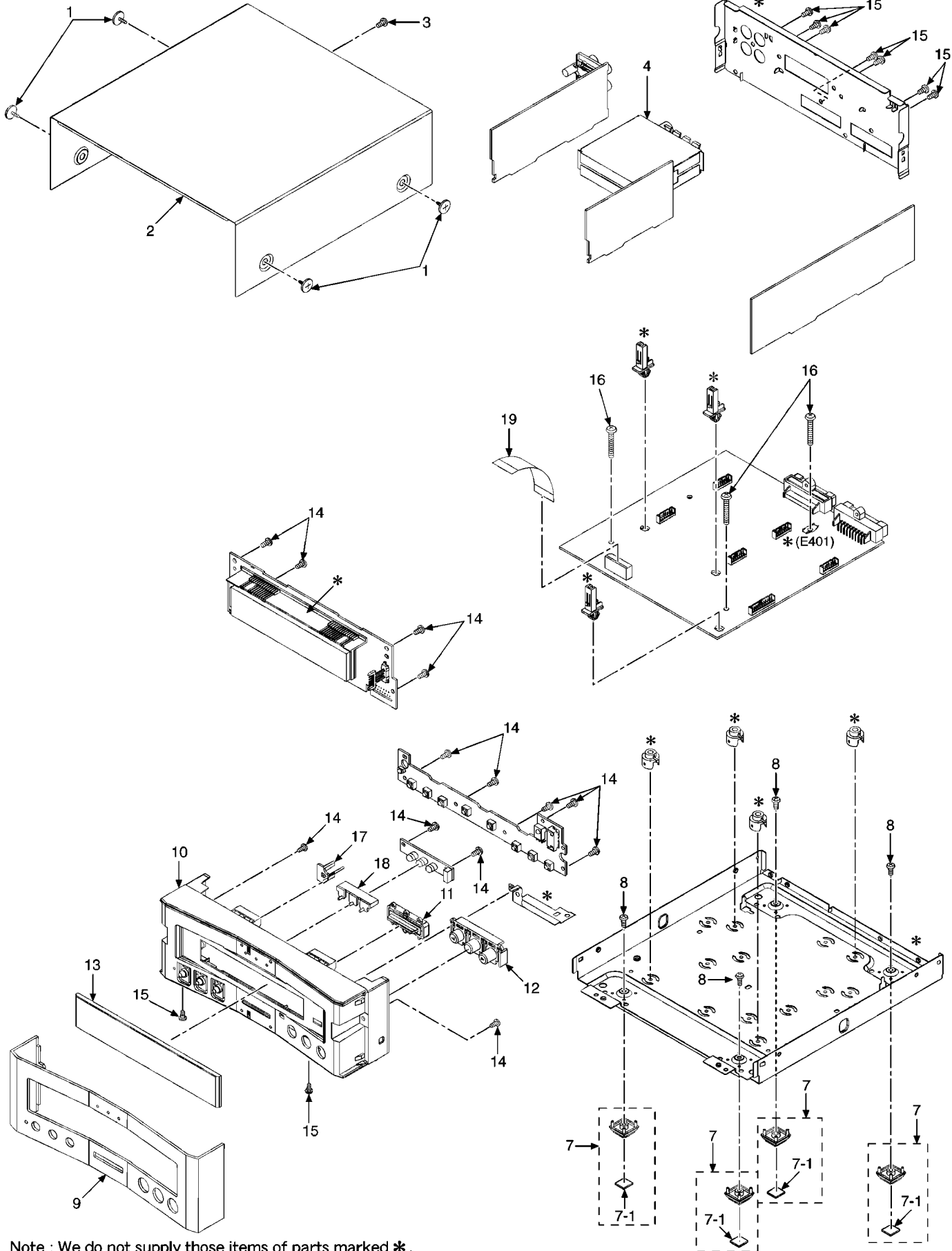

Note : We do not supply those items of parts marked \*.