

Service Manual

Tuner

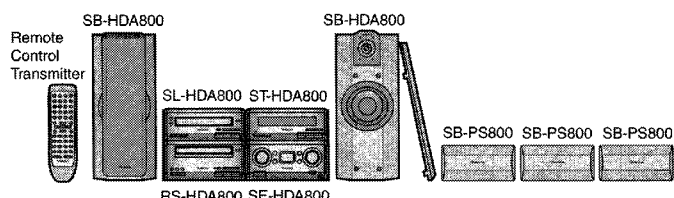

ST-HDA800E

Color

(N)..... Gold Type

Because of unique interconnecting cables, when a component requires service, send or bring in the entire system.

System	SC-HDA800
Integrated Amplifier	SE-HDA800
Stereo Tuner	ST-HDA800
DVD Audio/Video Player	SL-HDA800
Stereo Cassette Deck	RS-HDA800
Front Speakers*	SB-HDA800
Surround Speakers*	SB-PS800
Center Speakers*	

*: Made in Spain.

Specifications

Pre-amplifier section

Input sensitivity / impedance : 350mV/15k Ω
EXT IN;

Tuner section

FM frequency range : 87.50-108.00MHz
(0.05MHz steps)
FM antenna terminal(S) : 75 Ω (unbalanced)
AM frequency range : 522-1629kHz (9kHz steps)
520-1630kHz (10kHz steps)

Timer section

Clock : Quarts-lock type
Function : Play timer (everyday), Rec timer (everyday),
Sleep (120min, 30 mon, intervals)

General

Dimensions (W×H×D) : 210×76.3×251mm
Mass : 1.1kg

Notes : Specifications are subject to change without notice.
Mass and dimensions are approximate.

⚠ WARNING

This service information is designed for experienced repair technicians only and is not designed for use by the general public. It does not contain warnings or cautions to advise non-technical individuals of potential dangers in attempting to service a product. Products powered by electricity should be serviced or repaired only by experienced professional technicians. Any attempt to service or repair the product or products dealt with in this service information by anyone else could result in serious injury or death.

CONTENTS

	Page		Page
1 Note	2	6 Self-Diagnostic Function	5
2 Before Repair	2	6.1. To display the malfunction code	5
3 Location of Controls	2	6.2. To return to the normal display	5
4 Operation Checks and Component Replacement Procedures	3	6.3. Display contents	5
4.1. Checking for the FL P.C.B.	3	7 Type Illustration of ICs, Transistors and Diodes	6
4.2. Checking for the main P.C.B.	3	8 Schematic Diagram Notes	6
5 To Supply Power Source	4		

Technics®

© 2002 Matsushita Electric Industrial Co., Ltd. All rights reserved. Unauthorized copying and distribution is a violation of law.

9 Schematic Diagram	7
10 Printed Circuit Board Diagram	11
11 Wiring Connection Diagram	13
12 Block Diagram	15

13 Terminal Function of ICs	17
13.1. IC601 (C2BBGF000286):System Control/FL Drive	17
14 Replacement Parts List	18
15 Cabinet Parts Location	21

1 Note

Refer to the service manual for Model No. SE-HDA800 (Order No. AD0206125C2) for information on Accessories and Packaging.

2 Before Repair

This equipment (ST-HDA800), which is a component of the system, is supplied with power from the Amplifier (SE-HDA800). When repairing this equipment or checking operation of the system, be sure to connect to the amplifier with it.

Power supply and operation check in the state of it as a single equipment is impracticable.

3 Location of Controls

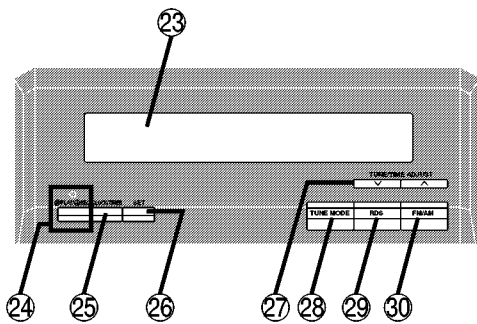

- ②③ **Display panel**
The display also shows information for the cassette deck, DVD player, and amplifier.
- ②④ **Play timer/record timer button and indicator**
(⊖PLAY/⊕REC)
- ②⑤ **Clock/timer button (CLOCK/TIMER)**
- ②⑥ **Set button (SET)**
- ②⑦ **Tuning/time adjust buttons**
(TUNE/TIME ADJUST \wedge , \vee)
- ②⑧ **Tuning mode button (TUNE MODE)**
- ②⑨ **RDS button (RDS)**
- ③⑩ **Band select button (FM/AM)**

4 Operation Checks and Component Replacement Procedures

- This section describes procedures for checking the operation of the major printed circuit boards and replacing the main components.
- For reassembly after operation checks or replacement, reverse the respective procedures. Special reassembly procedures are described only when required.

4.1. Checking for the FL P.C.B.

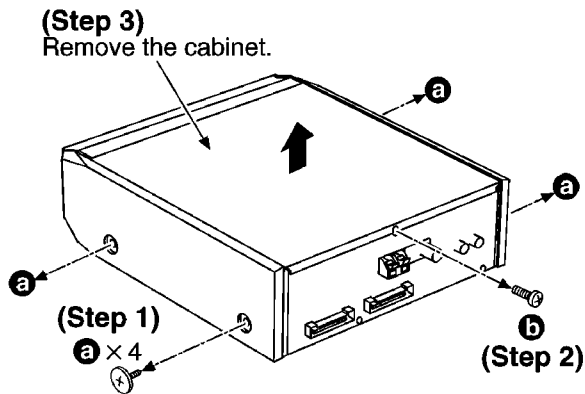

- Check the FL P.C.B. as shown below.

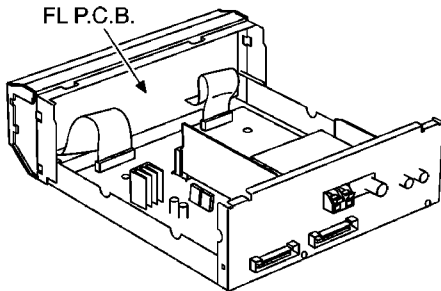

4.2. Checking for the main P.C.B.

- Follow the (Step 1) - (Step 3) of item 4.1.

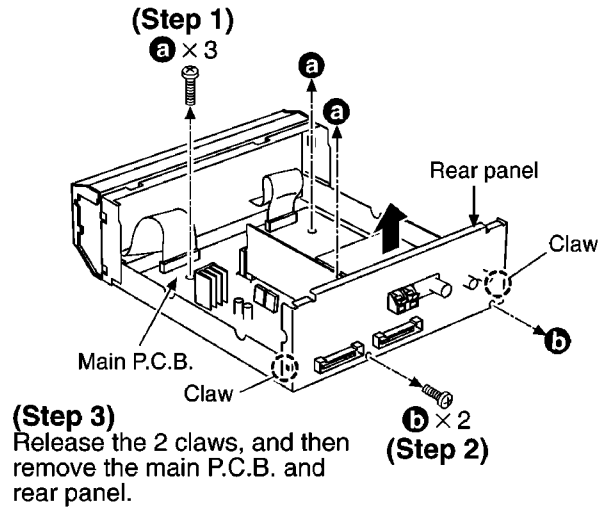

- Check the main P.C.B. as shown below.

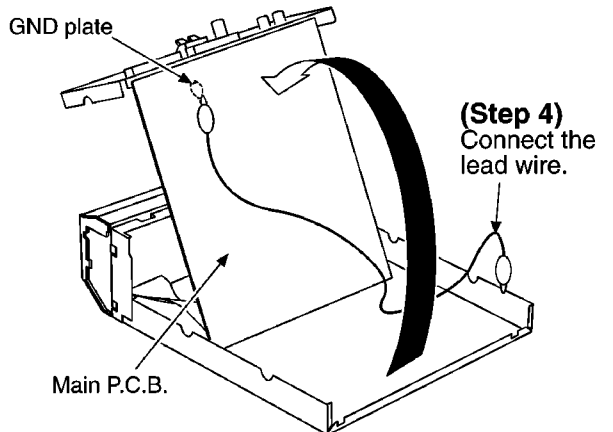

5 To Supply Power Source

This unit is designed to operate on power supplied from system connected.
When a component requires service, use the system connections to supply power source.
For system connections, refer to Fig.5-1.

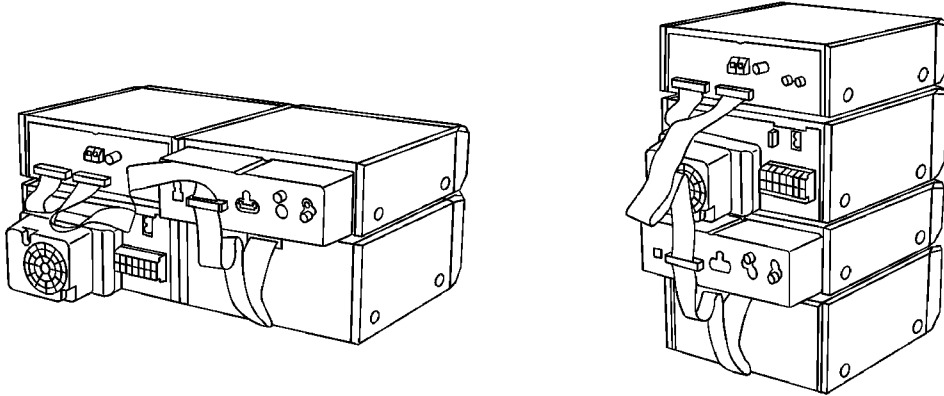

Fig.5-1.

6 Self-Diagnostic Function

This unit is equipped with a self-diagnostic function which, in the event of a malfunction, automatically displays a code indicating the nature of the malfunction.

Use this self-diagnostic function when servicing the unit.

6.1. To display the malfunction code

U70 DVD: Automatically displays on the tuner when a malfunction occurs. Refer to Fig.6-1.
U70 TAPE: Automatically displays on the tuner when a malfunction occurs. Refer to Fig.6-1.
F61: Automatically displays on the tuner when a malfunction occurs. Refer to Fig.6-1.

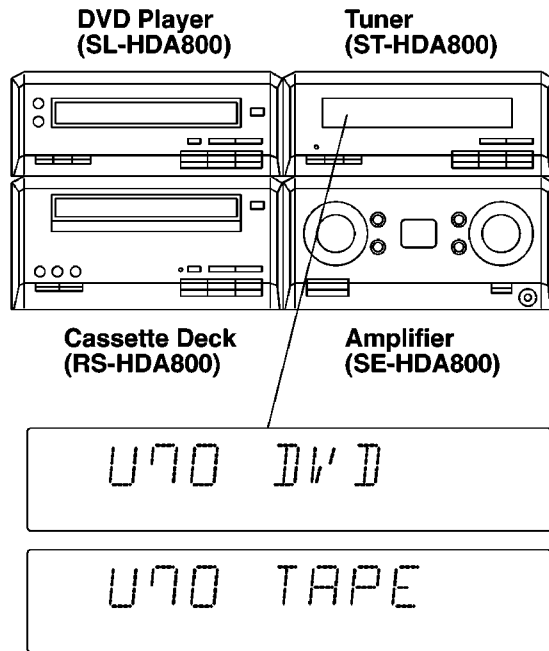

Fig.6-1.

6.2. To return to the normal display

1. For U70 DVD/U70 TAPE

- Press any operation button on the tuner.
- To re-display the code, switch the power off (POWER STANDBY button), and then switch power back on again.

2. For F61

- If F61 is displayed, the power will automatically be switched off.
- F61 will be displayed for 3 seconds, and then the clock will be displayed.
- To re-display the code, switch the power on. F61 will be re-displayed, and then after 3 seconds the clock will be displayed and the power will automatically switch off.

6.3. Display contents

6.3.1. U70 DVD/U70 TAPE (displayed automatically)

• Problem or condition

A bus-line communications error has occurred as a result of

the flat cables being inserted incorrectly, thus preventing the system from operating.

- If U70 is displayed on the tuner, the DVD Player or Cassette deck cannot be operated by remote control.

• Correction Procedure

- To check for correct insertion of the flat cables.
 - Insert each connectors until you hear a click.
 - Insert the flat cables at the back of the unit in the order indicated. Refer to Fig.6-2.
- Make sure the white side of the cable is on your right side. Refer to Fig.6-3.

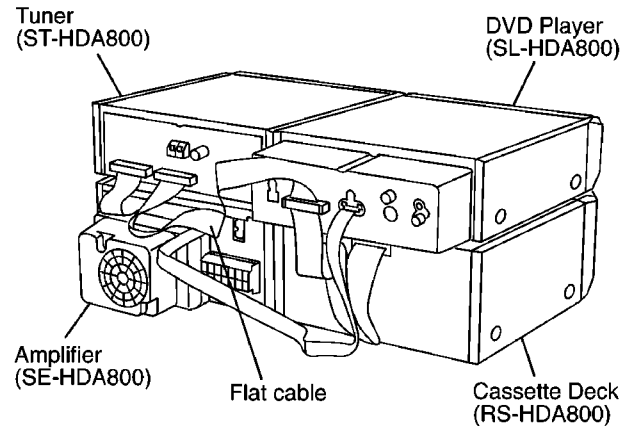

Fig.6-2.

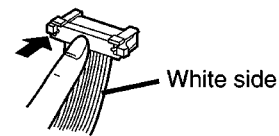

Fig.6-3.

2. Breakage of the flat cables. (Check and replace.)
3. If the problem is not corrected by items 1 and 2 above, this indicates a faulty IC.

ST-HDA800:

IC601 (C2BBGF000286)

SL-HDA800:

IC201 (C2BBFD000337)

RS-HDA800:

IC701 (C2BBED000031)

Check these ICs and replace.

6.3.2. F61

• Problem or condition

When the power switch is switched on, it automatically switches back off, making it impossible to switch power on.

• Correction procedure

Faulty the Amplifier (SE-HDA800) output IC (IC101). (When a DC voltage is applied to speaker terminals.)

7 Type Illustration of ICs, Transistors and Diodes

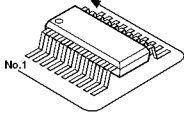
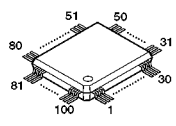
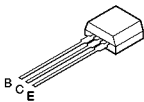
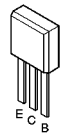
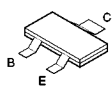
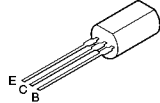
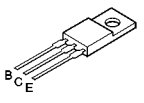
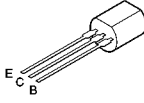
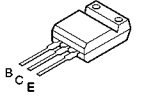
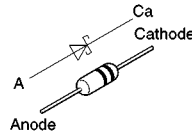
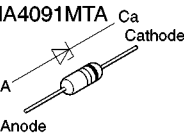
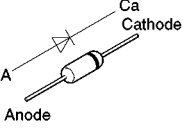
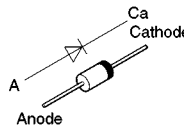
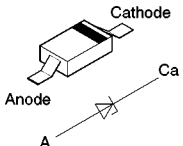
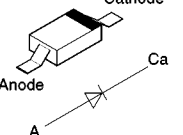
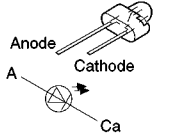
	<table border="1"> <tr><td>BU4052BCF-E2</td><td>16PIN</td></tr> <tr><td>BU4053BCFE2</td><td>16PIN</td></tr> <tr><td>C1BB00000527</td><td>16PIN</td></tr> <tr><td>C1BB00000528</td><td>20PIN</td></tr> <tr><td>NJM4558MTE1</td><td>8PIN</td></tr> </table>	BU4052BCF-E2	16PIN	BU4053BCFE2	16PIN	C1BB00000527	16PIN	C1BB00000528	20PIN	NJM4558MTE1	8PIN			<table border="1"> <tr><td>2SD2144STA</td></tr> <tr><td>DTA114ESTP</td></tr> <tr><td>DTA114TSTP</td></tr> <tr><td>DTC114ESTP</td></tr> <tr><td>DTC143XSTP</td></tr> </table>	2SD2144STA	DTA114ESTP	DTA114TSTP	DTC114ESTP	DTC143XSTP	<table border="1"> <tr><td>2SA1309ATA</td></tr> <tr><td>2SC3311ATA</td></tr> </table> 	2SA1309ATA	2SC3311ATA
BU4052BCF-E2	16PIN																					
BU4053BCFE2	16PIN																					
C1BB00000527	16PIN																					
C1BB00000528	20PIN																					
NJM4558MTE1	8PIN																					
2SD2144STA																						
DTA114ESTP																						
DTA114TSTP																						
DTC114ESTP																						
DTC143XSTP																						
2SA1309ATA																						
2SC3311ATA																						
<table border="1"> <tr><td>2SD1819ATX</td></tr> <tr><td>UN5214TX</td></tr> </table> 	2SD1819ATX	UN5214TX	<table border="1"> <tr><td>2SC3940AQSTA</td></tr> </table> 	2SC3940AQSTA	<table border="1"> <tr><td>2SD2374PQAU</td></tr> </table> 	2SD2374PQAU	<table border="1"> <tr><td>2SB621AQRSTA</td></tr> </table> 	2SB621AQRSTA	<table border="1"> <tr><td>2SB1417PQTA</td></tr> <tr><td>2SD2137PQTA</td></tr> </table> 	2SB1417PQTA	2SD2137PQTA	<table border="1"> <tr><td>MA719TA</td></tr> </table> 	MA719TA									
2SD1819ATX																						
UN5214TX																						
2SC3940AQSTA																						
2SD2374PQAU																						
2SB621AQRSTA																						
2SB1417PQTA																						
2SD2137PQTA																						
MA719TA																						
<table border="1"> <tr><td>MA4056HTA</td></tr> <tr><td>MA4062HTA</td></tr> <tr><td>MA4082LTA</td></tr> <tr><td>MA4091MTA</td></tr> </table> 	MA4056HTA	MA4062HTA	MA4082LTA	MA4091MTA	<table border="1"> <tr><td>MA165TA</td></tr> <tr><td>MA29WATA</td></tr> </table> 	MA165TA	MA29WATA	<table border="1"> <tr><td>RL1N4003N02</td></tr> </table> 	RL1N4003N02	<table border="1"> <tr><td>MA8062MTX</td></tr> <tr><td>MA8051MTX</td></tr> </table> 	MA8062MTX	MA8051MTX	<table border="1"> <tr><td>MA111TX</td></tr> <tr><td>1SS380TE-17</td></tr> </table> 	MA111TX	1SS380TE-17	<table border="1"> <tr><td>LNJ201LPQJA</td></tr> </table> 	LNJ201LPQJA					
MA4056HTA																						
MA4062HTA																						
MA4082LTA																						
MA4091MTA																						
MA165TA																						
MA29WATA																						
RL1N4003N02																						
MA8062MTX																						
MA8051MTX																						
MA111TX																						
1SS380TE-17																						
LNJ201LPQJA																						

8 Schematic Diagram Notes

- This schematic diagram may be modified at any time with the development of new technology.

Notes:

- S601:** Tuning/time adjust up switch (TUNE/TIME ADJUST \wedge)
- S602:** Tuning/time adjust down switch (TUNE/TIME ADJUST \vee)
- S603:** Play timer/record timer switch (\odot PLAY/ \ominus REC)
- S604:** Clock/timer switch (CLOCK/TIMER)
- S605:** Set switch (SET)
- S606:** Tuning mode switch (TUNE MODE)
- S607:** RDS switch (RDS)
- S608:** Band select switch (FM/AM)

- Indicated voltage values are the standard values for the unit measured by the DC electronic circuit tester (high-impedance) with the chassis taken as standard. Therefore, there may exist some errors in the voltage values, depending on the internal impedance of the DC circuit tester.

No mark : FM
() : AM

- Important safety notice:

Components identified by \triangle mark have special characteristics important for safety.

Furthermore, special parts which have purposes of fire-retardant (resistors), high-quality sound (capacitors), low-

noise (resistors), etc. are used.

When replacing any of components, be sure to use only manufacturer's specified parts shown in the parts list.

- The supply part number is described alone in the replacement parts list.

• Caution!

IC and LSI are sensitive to static electricity.

Secondary trouble can be prevented by taking care during repair.







Cover the parts boxes made of plastics with aluminum foil.

Ground the soldering iron.

Put a conductive mat on the work table.

Do not touch the legs of IC or LSI with the fingers directly.

- Voltage and signal line

-  : Positive voltage line
-  : Negative voltage line
-  : FM signal line
-  : FM OSC signal line
-  : AM signal line
-  : AM OSC signal line
-  : FM/AM signal line

9 Schematic Diagram

SCHEMATIC DIAGRAM-1

NOTE:
The number which noted at the connectors on the schematic diagram as "SCHEMATIC DIAGRAM-1" or "SCHEMATIC DIAGRAM-2" indicates the schematic diagram serial number located on the left corner in the schematic diagram.

A FL CIRCUIT

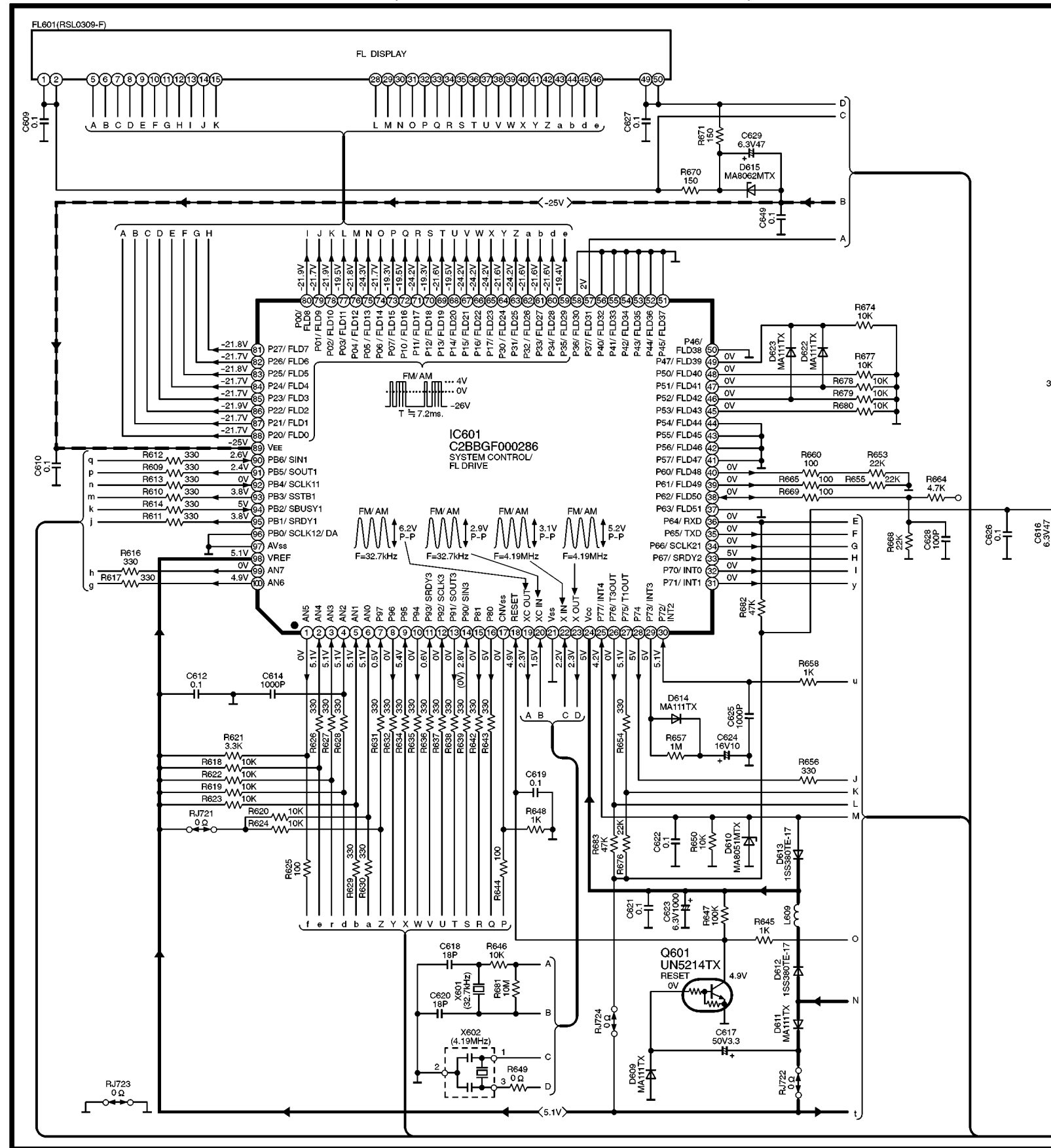

B OPERATION CIRCUIT

→ POSITIVE VOLTAGE LINE
→ NEGATIVE VOLTAGE LINE

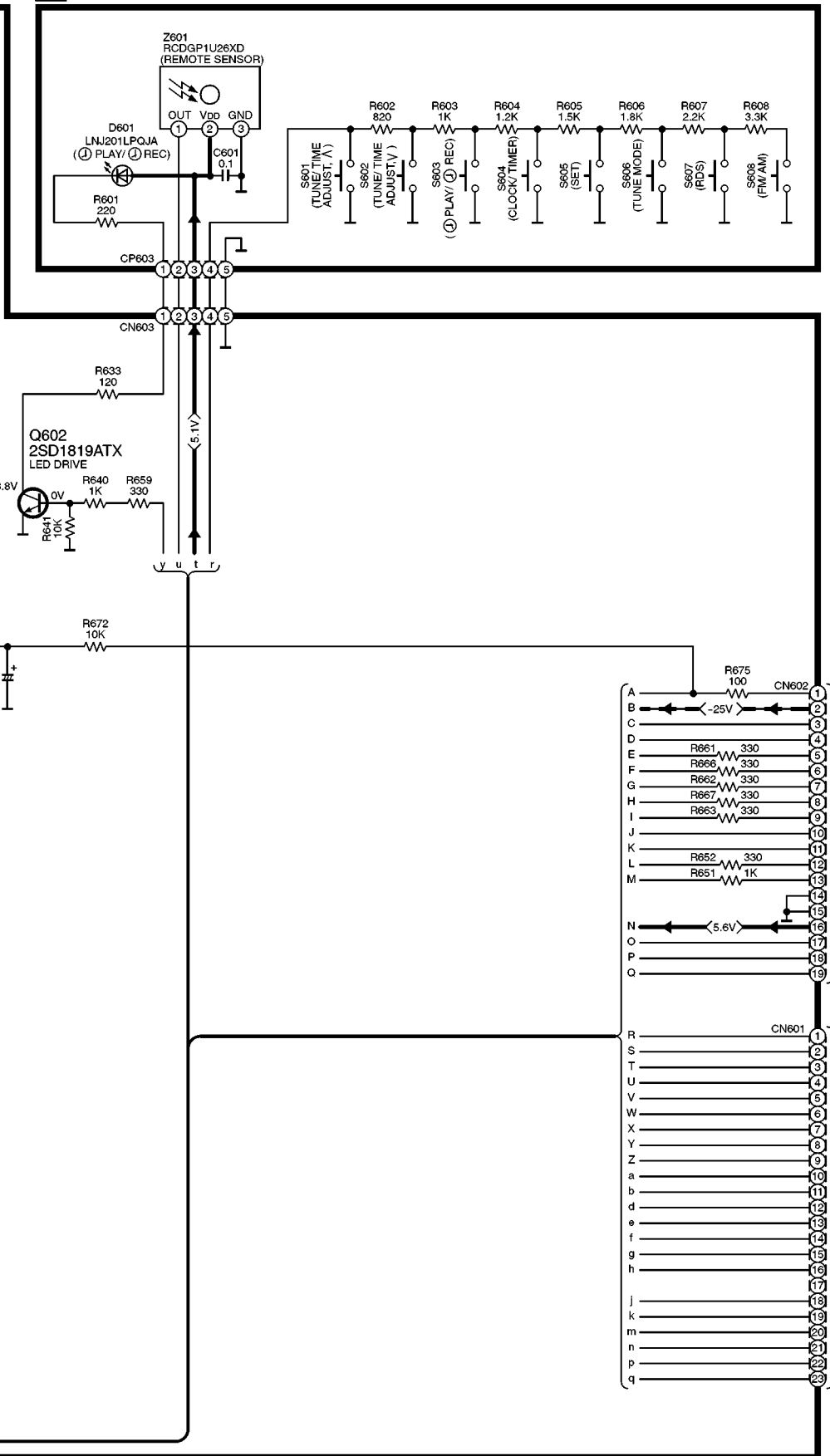

ST-HDA800(E) FL ,OPERATION CIRCUIT DIAGRAM

SCHEMATIC DIAGRAM-2

C MAIN CIRCUIT

→ : POSITIVE VOLTAGE LINE → : NEGATIVE VOLTAGE LINE → : FM/ AM SIGNAL LINE

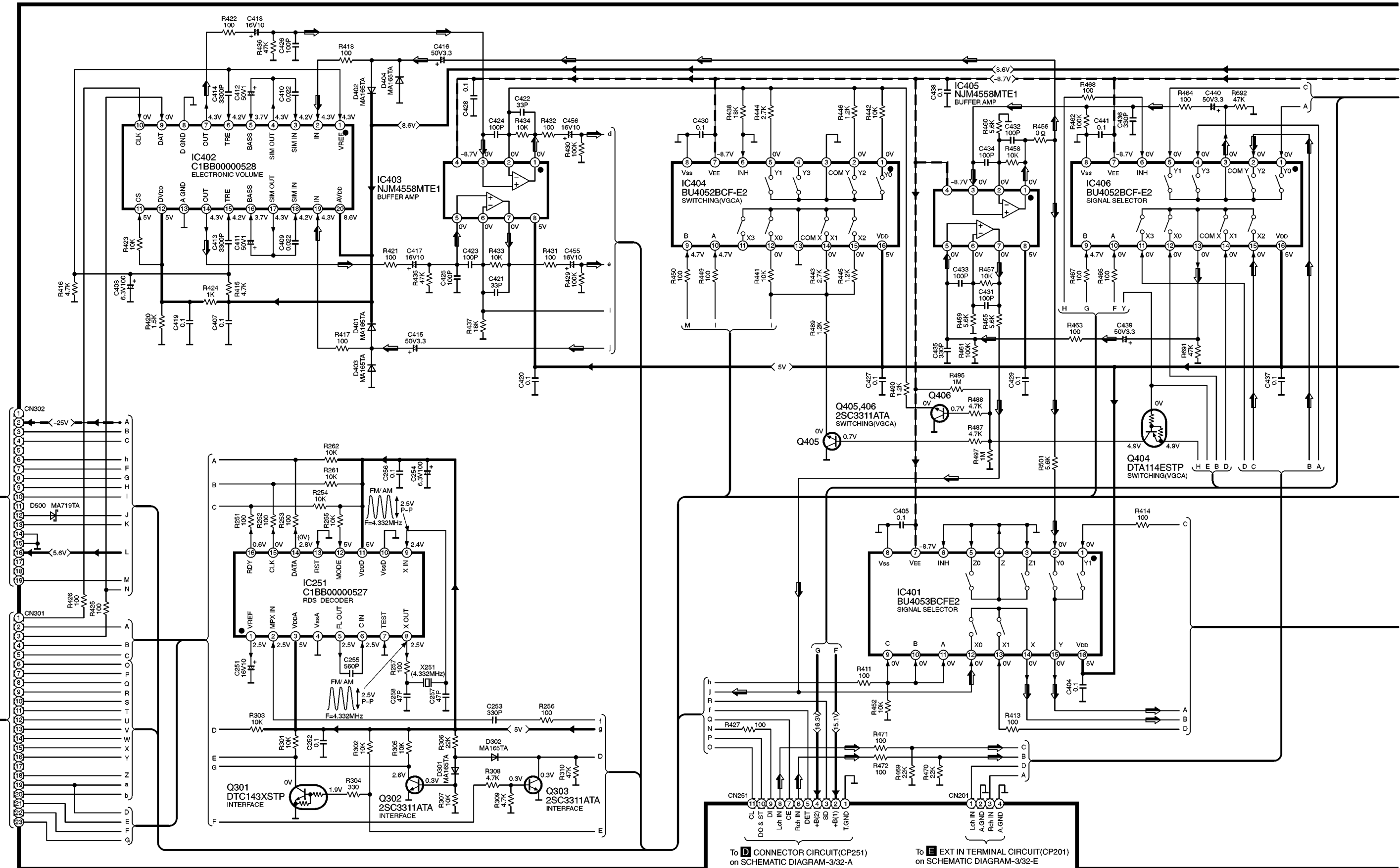

To D CONNECTOR CIRCUIT (CP251) on SCHEMATIC DIAGRAM-3/32-A

To E EXT IN TERMINAL CIRCUIT (CP201) on SCHEMATIC DIAGRAM-3/32-E

SCHEMATIC DIAGRAM-3

C MAIN CIRCUIT

→ : POSITIVE VOLTAGE LINE → : NEGATIVE VOLTAGE LINE → : FM/AM SIGNAL LINE

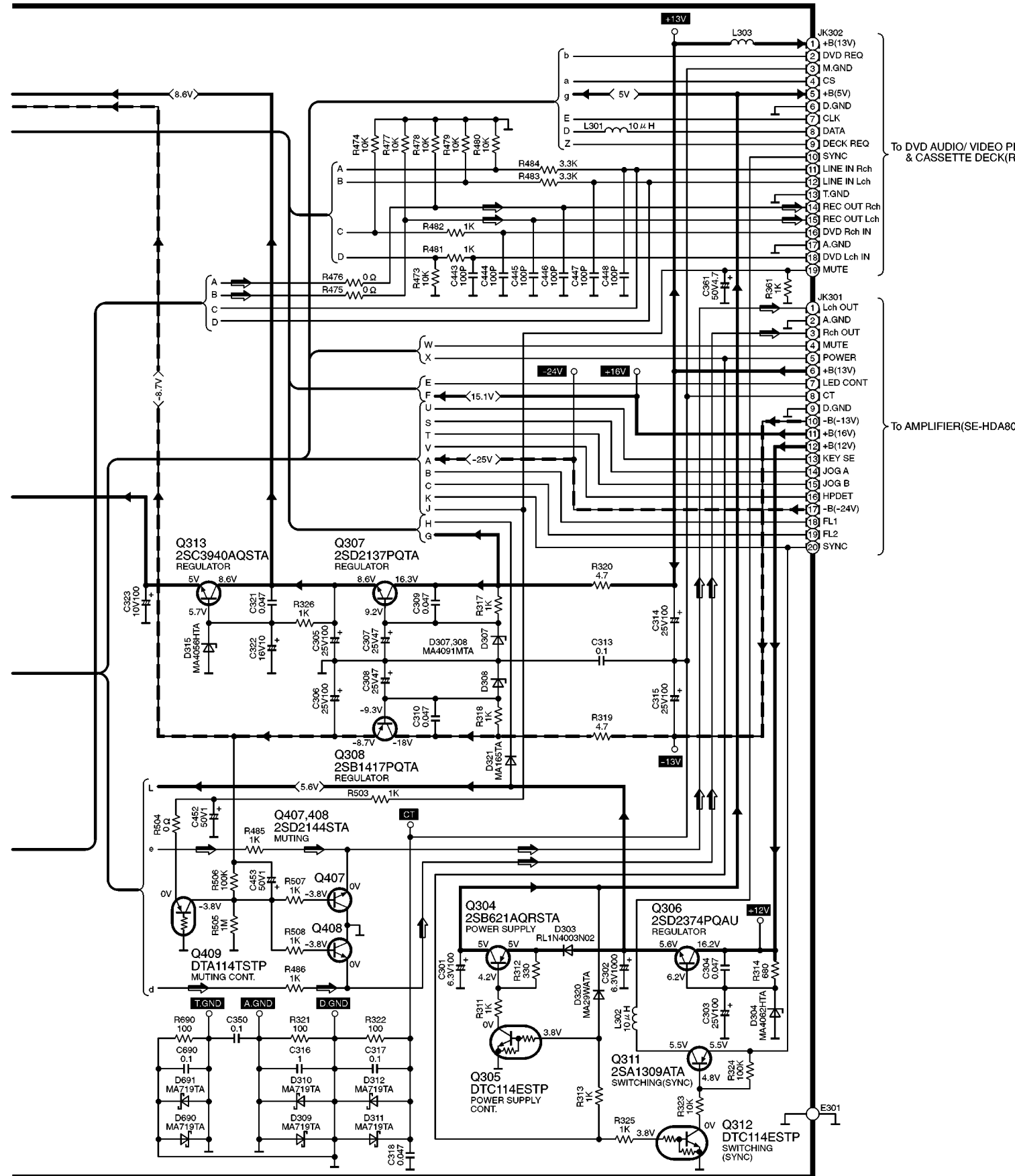

To DVD AUDIO/VIDEO PLAYER(SL-HDA800) & CASSETTE DECK(RS-HDA800)

To AMPLIFIER(SE-HDA800)

To C MAIN CIRCUIT(CN201) on SCHEMATIC DIAGRAM-2/21,22-A

E EXT IN TERMINAL CIRCUIT

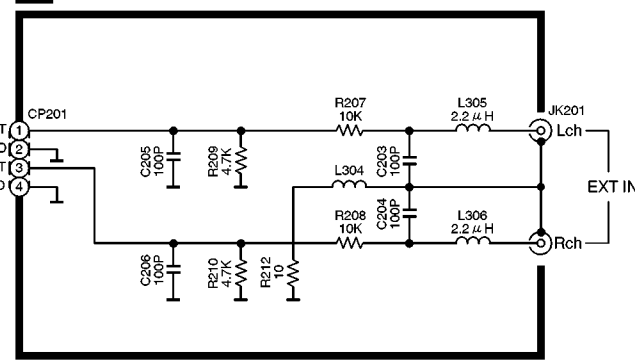

D CONNECTOR CIRCUIT

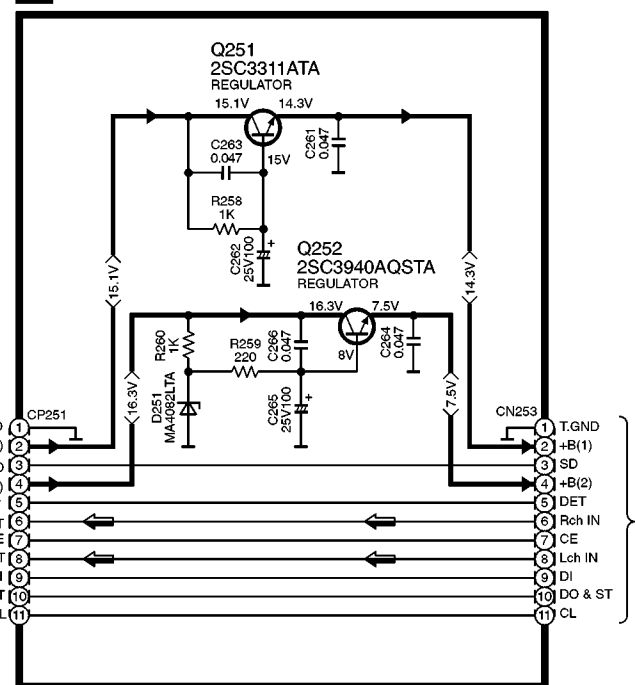

To C MAIN CIRCUIT(CN251) on SCHEMATIC DIAGRAM-2/19,20-A

To TUNER UNIT(A) on SCHEMATIC DIAGRAM-4/11,12-A

ST-HDA800(E) MAIN , CONNECTOR , EXT IN TERMINAL CIRCUIT DIAGRAM

SCHEMATIC DIAGRAM-4

TUNER UNIT(RAN0005EM-2)

→ : POSITIVE VOLTAGE LINE ◻◻◻ : FM OSC SIGNAL LINE ◻◻◻◻◻ : AM OSC SIGNAL LINE ◻◻◻◻◻◻◻ : FM SIGNAL LINE ◻◻◻◻◻◻◻◻◻ : AM SIGNAL LINE ◻◻◻◻◻◻◻◻◻◻◻ : FM/AM SIGNAL LINE

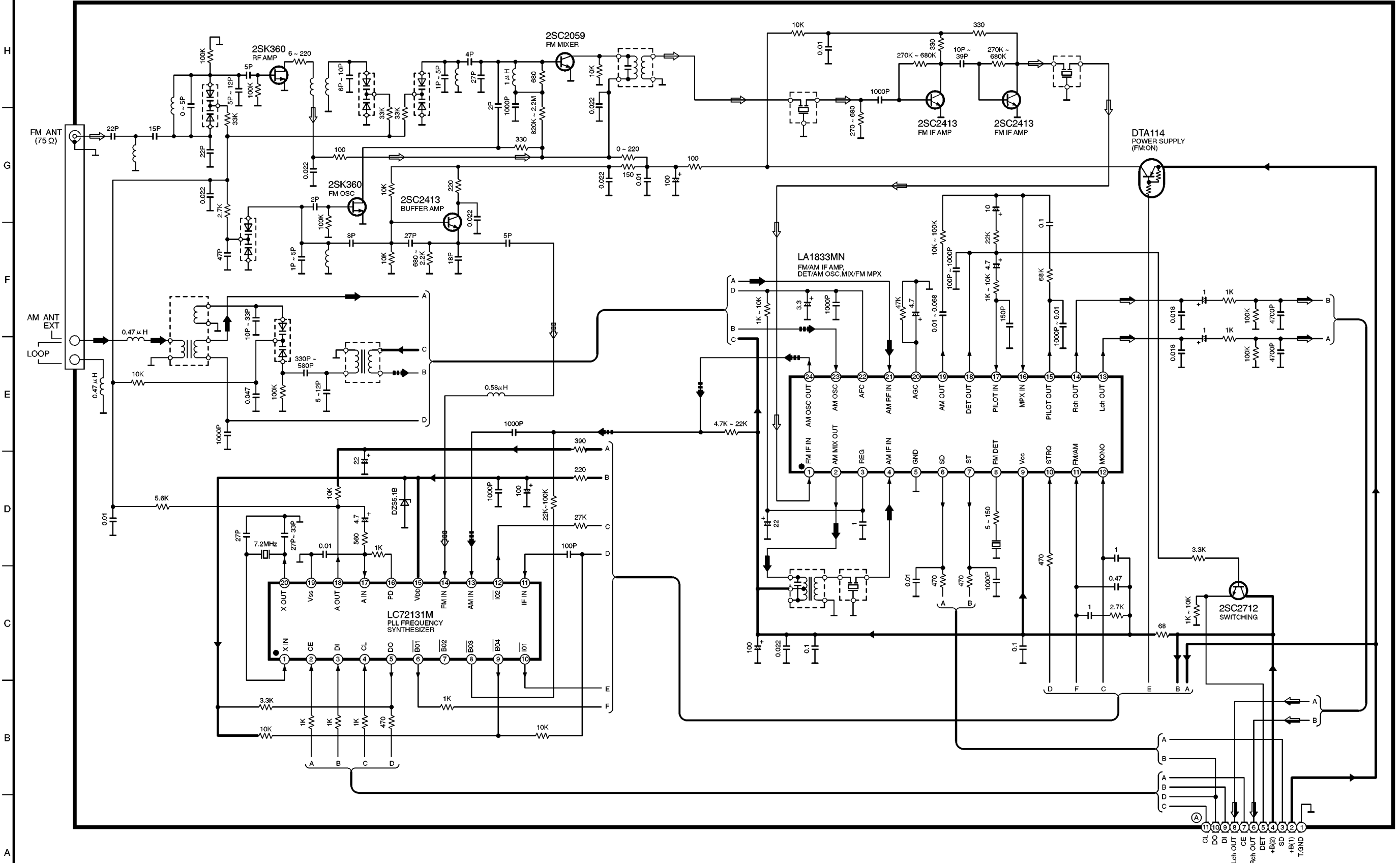

To **D** CONNECTOR CIRCUIT(CN253)
 on SCHEMATIC DIAGRAM-3/35-A,B
 ST-HDA800(E) TUNER UNIT CIRCUIT DIAGRAM

10 Printed Circuit Board Diagram

Note: This printed circuit board diagram may be modified at any time with the development of new technology.

A FL P.C.B.

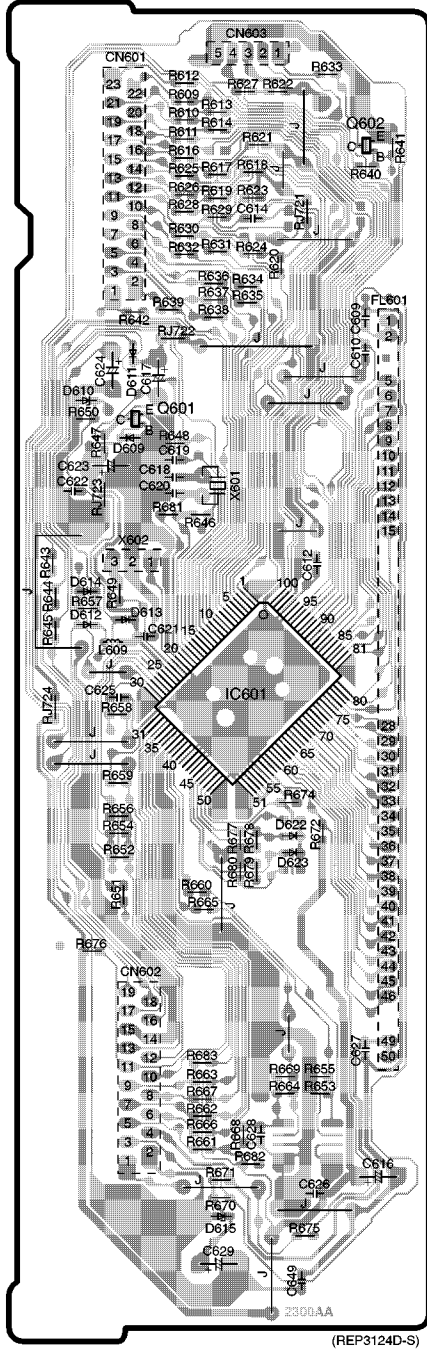

B OPERATION P.C.B.

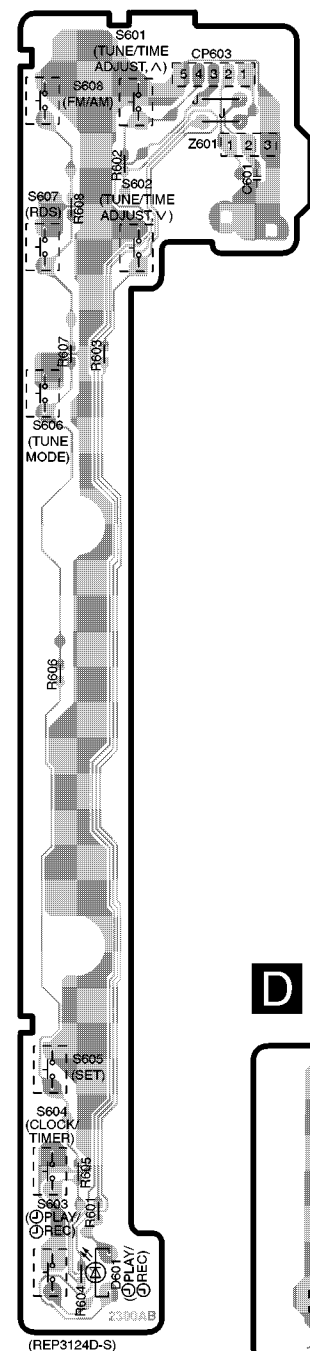

D CONNECTOR P.C.B.

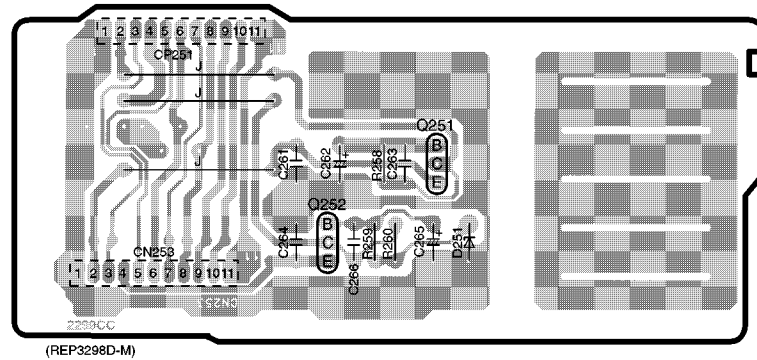

E EXT IN TERMINAL P.C.B.

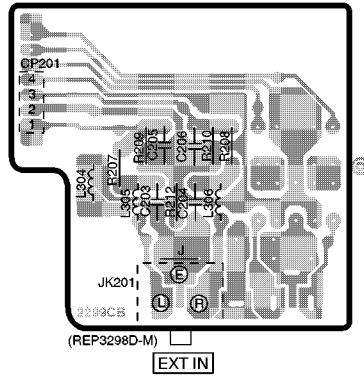

C MAIN P.C.B.

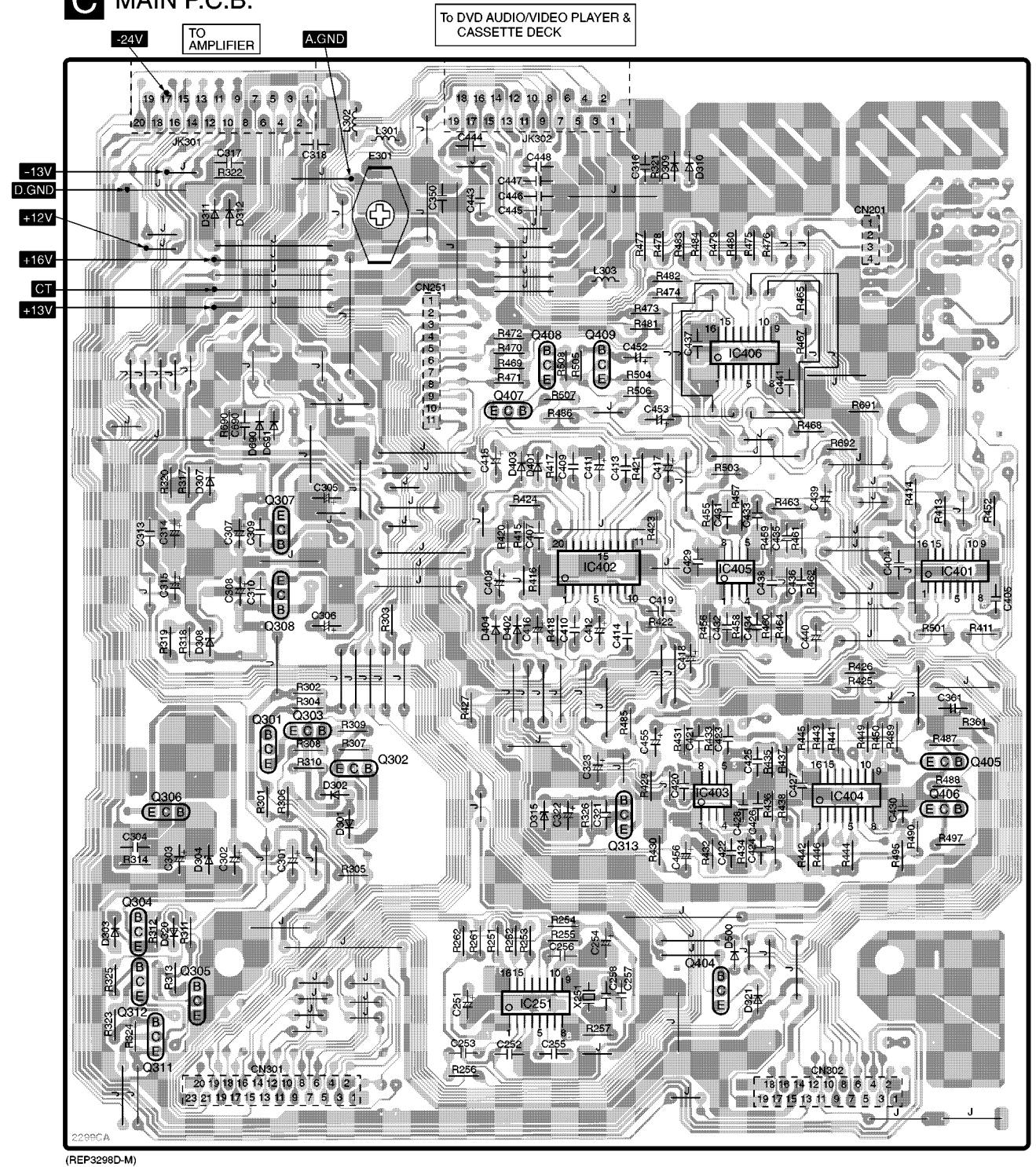

11 Wiring Connection Diagram

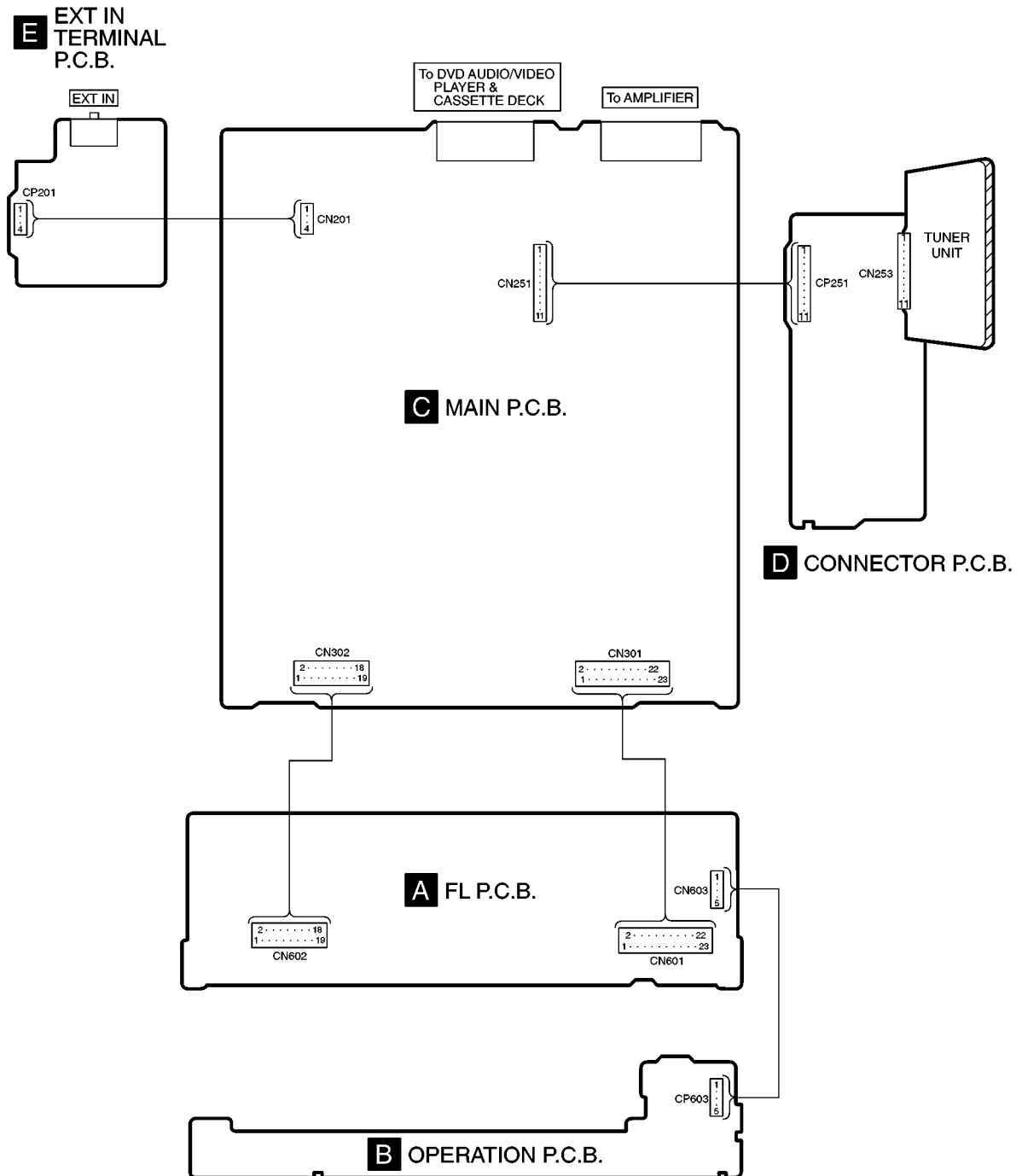

12 Block Diagram

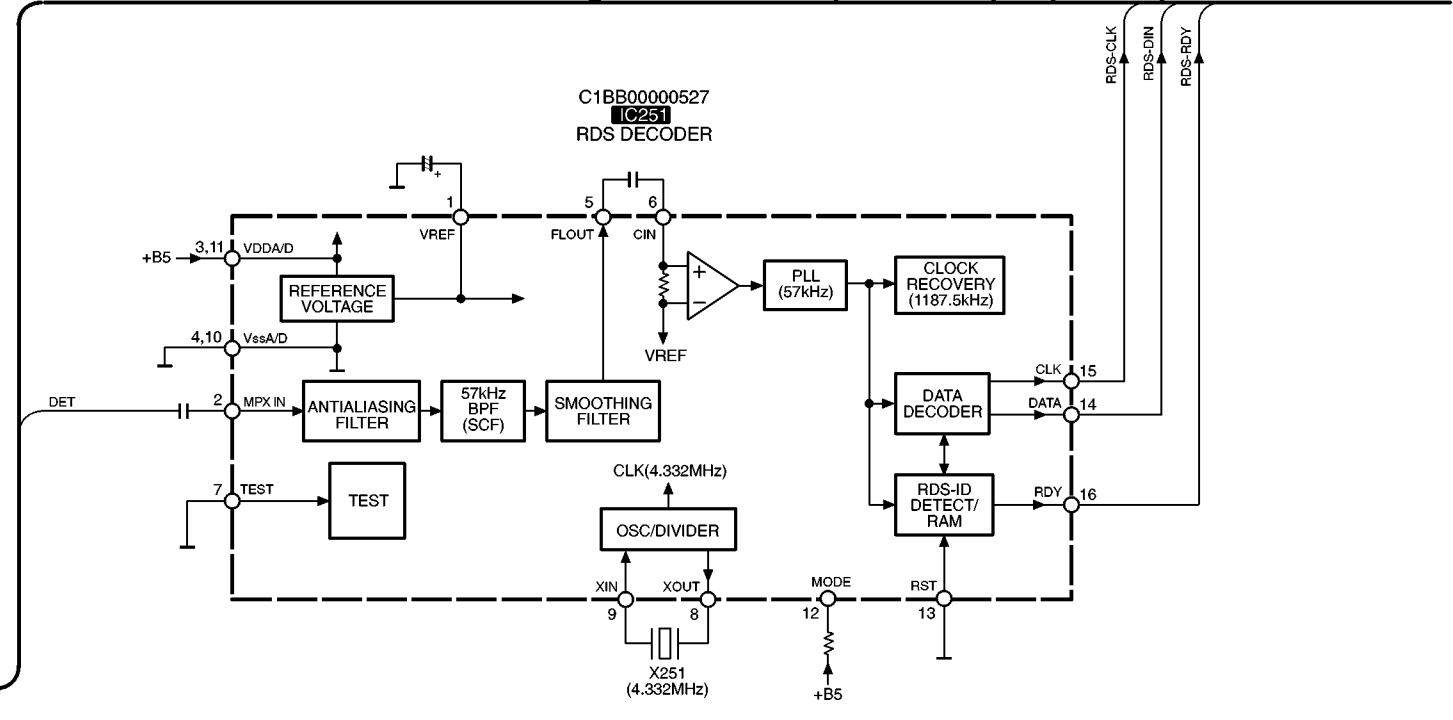
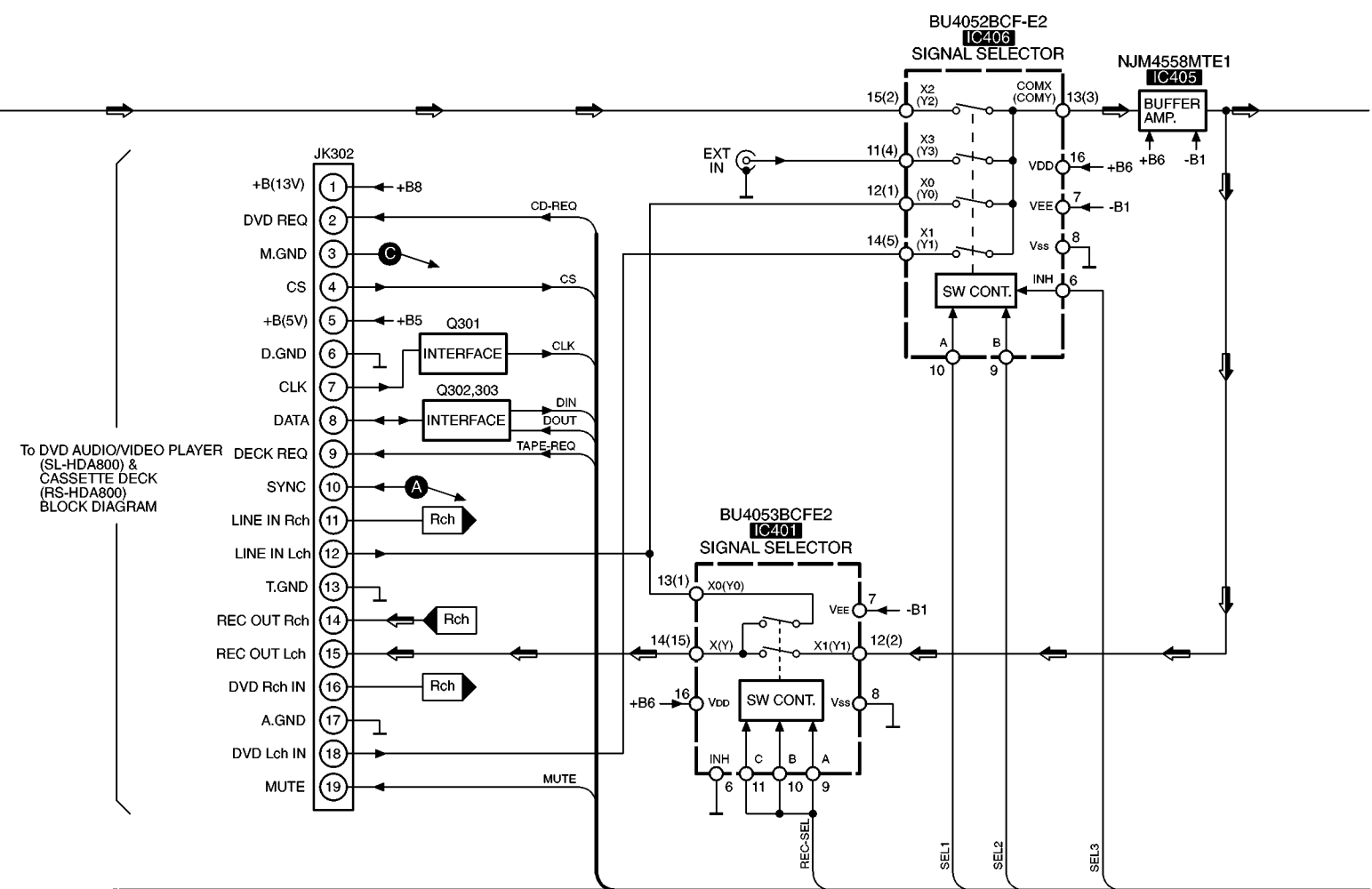
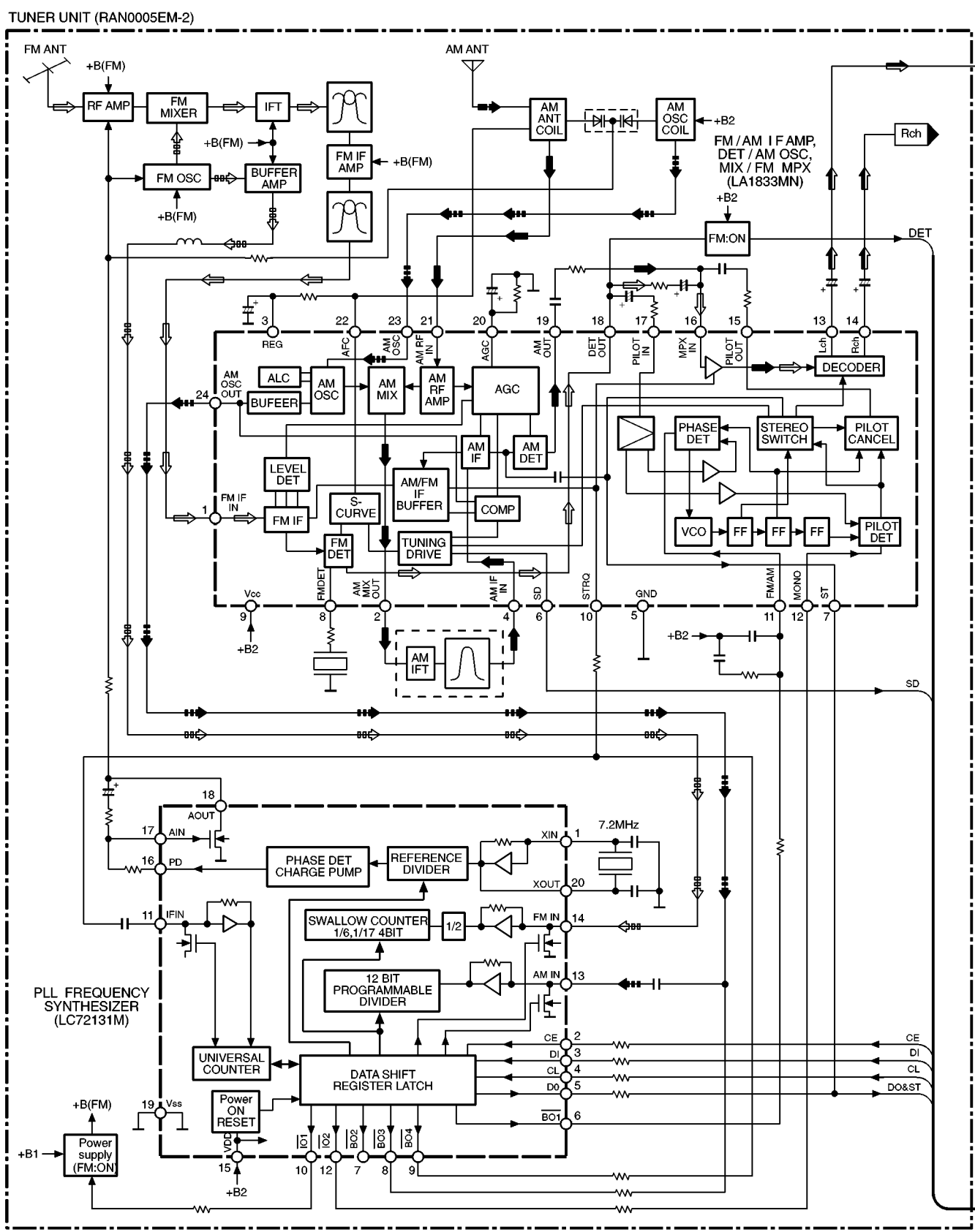

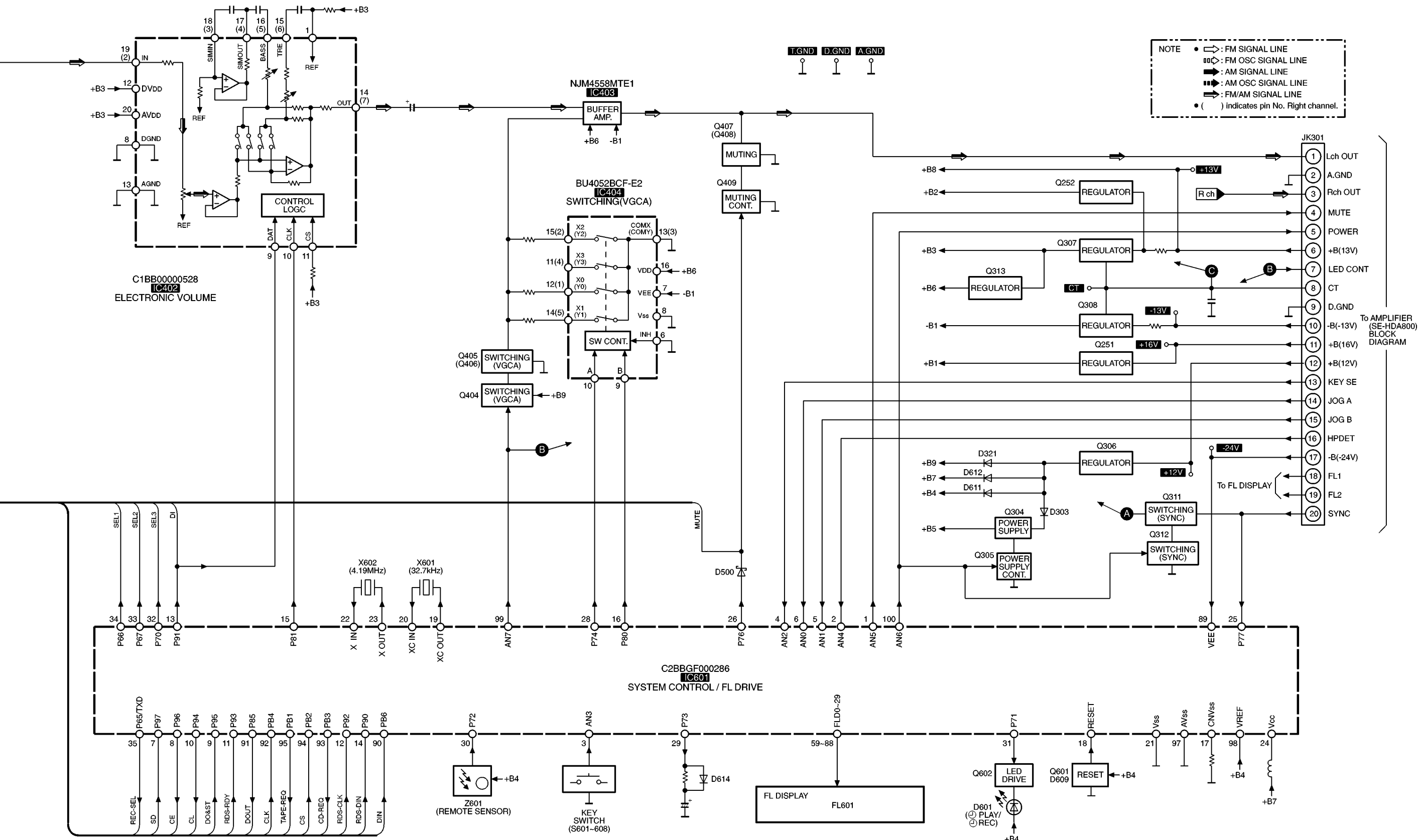

ST-HDA800(E) BLOCK DIAGRAM

13 Terminal Function of ICs

13.1. IC601 (C2BBGF000286): System Control/FL Drive

Pin No.	Terminal Name	I/O	Function
1	AN5	O	Muting signal output
2	AN4	I	Headphone connection detect signal input
3	AN3	I	Key switch signal input
4	AN2	I	Key switch signal input from Amplifier
5	AN1	I	Selector switch signal input from Amplifier
6	AN0	I	Volume switch signal input from Amplifier
7	P97	I	Tuner signal detection input from Z101
8	P96	O	Chip enable signal output for Z101
9	P95	I	Data signal input from Z101
10	P94	O	Clock signal output for Z101
11	P93/ SRDY3	I	RDS ready signal input from IC251
12	P92/ SCLK3	I	RDS clock signal input from IC251
13	P91/ SOUT3	O	Control data signal output for IC402 and Z101
14	P90/ SIN3	I	RDS data signal input from IC251
15	P81	O	Clock signal output for serial data transfer
16	P80	O	VGCA switch control signal output
17	CNV _{SS}	-	GND terminal
18	RESET	I	Reset signal input
19	XC OUT	O	Oscillator connected terminal (F=32.7 kHz)
20	XC IN	I	
21	V _{SS}	-	GND terminal
22	X IN	I	Oscillator connected terminal (F=4.19 MHz)
23	X OUT	O	
24	V _{CC}	I	Power supply terminal
25	P77/ INT4	I	Power failure detect signal input
26	P76/ T3OUT	O	Muting signal output
27	P75/ T1OUT	-	Not used, connected to VREF
28	P74	O	VGCA switch control signal output
29	P73/ INT3	O	CR timer terminal for clock backup
30	P72/ INT2	I	Remote control signal input
31	P71/ INT1	O	LED drive signal output
32	P70/ INT0	O	Select signal output for IC406
33	P67/ SRDY2	O	Select signal output for IC406
34	P66/ SCLK21	O	Select signal output for IC406
35	P65/ TXD	O	Record select signal output for IC401
36	P64/ RXD	-	Not used, connected to VREF
37	P63/ FLD51	-	GND terminal
38	P62/ FLD50	I/O	Data signal input/output
39	P61/ FLD49	O	Chip select signal output
40	P60/ FLD48	O	Clock signal output
41	P57/ FLD47 P54/ FLD44	-	Not used, connected to GND

Pin No.	Terminal Name	I/O	Function
45	P53/ FLD43 P40/ FLD32	-	Not used, connected to GND
56	P37/ FLD31	-	Not used, connected to VREF
57	P36/ FLD30	-	Not used, connected to GND
58	P35/ FLD29 P03/ FLD11	O	FL segment control signal output
77	P02/ FLD10 P20/ FLD0	O	FL grid control signal output
78	V _{EE}	I	Power supply terminal (Negative)
88	PB6/ SIN1	I	Communication data signal input
89	PB5/ SOUT1	O	Communication data signal output
90	PB4/ SCLK11	I	Communication clock signal input
91	PB3/ SSTB1	O	Communication request signal output for DVD
92	PB2/ SBUSY1	I	Communication chip select signal input
93	PB1/ SRDY1	O	Communication request signal output for Deck
94	PB0/ SCLK12/ DA	-	Not used, connected to GND
95	AV _{SS}	-	GND terminal
96	VREF	I	Reference voltage input
97	AN7	O	LED (VGCA) control signal output
98	AN6	O	Power supply control signal output

14 Replacement Parts List

Notes:

- Important safety notice:

Components identified by Δ mark have special characteristics important for safety.

Furthermore, special parts which have purposes of fire-retardant (resistors), high-quality sound (capacitors), low-noise (resistors), etc. are used.

When replacing any of components, be sure to use only manufacturer's specified parts shown in the parts list.

- The marking [RTL] indicates that Retention Time is Limited for this item. After the discontinuation of this assembly in production, the item will continue to be available for a specific period of time. The retention period of availability is dependent on the type of assembly, and in accordance with the laws governing part and product retention. After the end of this period, the assembly will no longer be available.
- All parts are supplied by MESA.

Ref. No.	Part No.	Part Name & Description	Pcs	Remarks
1	RHD30082-K1	SCREW	4	
2	RKM0413A-N	CABINET	1	
3	XTB3+8JFZ	SCREW	1	
4	REZ1379	FFC (23P)	1	
5-1	RKA0083-K	CUSHION	4	
5	RKA0114-K	FOOT	4	
6	REZ1359	FFC (19P)	1	
7	RG0189D-S	MAIN PANEL	1	
8	RAN0005EM-2	TUNER UNIT	1	
9	RYP0974-S	SUB PANEL	1	
10	SHE170-2	P.C.B. SUPPORT	4	
11	RGL0529-Q	INDICATOR, TIMER	1	
12	RKW0629-R	FL WINDOW	1	
13	XTBS26+8J	SCREW	9	
14	XTBS3+8JFZ1	SCREW	9	
15	XTB3+12JFZ	SCREW	3	
16	XTB3+5JFZ	SCREW	4	
17	RGK1326-1M	SIDE PANEL (L)	1	
18	RGK1327-1M	SIDE PANEL (R)	1	
19	XYN3+P8	SCREW	1	
20	RGK1330-S	SIDE ORNAMENT (L)	1	
21	RGK1331-S	SIDE ORNAMENT (R)	1	
C203-06	ECBA1H101KB5	50V 100P	4	
C251	ECA1CAK100XB	16V 10U	1	
C252	ECBT1H104ZF5	50V 0.1U	1	F1E1H104A001
C253	ECBT1H331KB3	50V 330P	1	
C254	ECA0JAK101XB	6.3V 100U	1	
C255	ECBT1H561KB3	50V 560P	1	
C256	ECBT1H104ZF5	50V 0.1U	1	F1E1H104A001
C257, 58	ECBT1H470J3	50V 47P	2	
C261	ECBT1H473KB5	50V 0.047U	1	F1D1H473A012
C262	ECA1EAM101XB	25V 100U	1	
C263, 64	ECBT1H473KB5	50V 0.047U	2	F1D1H473A012
C265	ECA1EAM101XB	25V 100U	1	
C266	ECBT1H473KB5	50V 0.047U	1	F1D1H473A012
C301	ECA0JAK101XB	6.3V 100U	1	
C302	ECA0JAM102XB	6.3V 1000U	1	
C303	ECA1EAM101XB	25V 100U	1	
C304	ECBT1H473KB5	50V 0.047U	1	F1D1H473A012
C305, 06	ECA1EPX101B	25V 100U	2	
C307, 08	ECA1EPX470B	25V 47U	2	
C309, 10	ECBT1H473KB5	50V 0.047U	2	F1D1H473A012
C313	ECBT1H104ZF5	50V 0.1U	1	F1E1H104A001
C314, 15	ECA1EAM101XB	25V 100U	2	
C316	ECBT1C105ZF5	16V 1U	1	F1E1C1050001

Ref. No.	Part No.	Part Name & Description	Pcs	Remarks
C317	ECBT1H104ZF5	50V 0.1U	1	F1E1H104A001
C318	ECBT1H473KB5	50V 0.047U	1	F1D1H473A012
C321	ECBT1H473KB5	50V 0.047U	1	F1D1H473A012
C322	ECA1CAK100XB	16V 10U	1	
C323	ECA1APX101B	10V 100U	1	
C350	ECBT1H104ZF5	50V 0.1U	1	F1E1H104A001
C361	ECA1HAK4R7XB	50V 4.7U	1	
C404, 05	ECBT1H104ZF5	50V 0.1U	2	F1E1H104A001
C407	ECBT1H104ZF5	50V 0.1U	1	F1E1H104A001
C408	ECA0JAK101XB	6.3V 100U	1	
C409, 10	ECQB1H223JF3	50V 0.022U	2	
C411, 12	ECA1HAK010XI	50V 1U	2	
C413, 14	ECBT1C332KR5	16V 3300P	2	ECBT1C332KR3
C415, 16	RCE1HKA3R3BG	50V 3.3U	2	F2A1H3R3A015
C417, 18	ECA1CAK100XB	16V 10U	2	
C419, 20	ECBT1H104ZF5	50V 0.1U	2	F1E1H104A001
C421, 22	ECBT1H330J5	50V 33P	2	F1D1H330A006
C423-26	ECBA1H101KB5	50V 100P	4	
C427-30	ECBT1H104ZF5	50V 0.1U	4	F1E1H104A001
C431-34	ECBA1H101KB5	50V 100P	4	
C435, 36	ECBT1H331KB3	50V 330P	2	
C437, 38	ECBT1H104ZF5	50V 0.1U	2	F1E1H104A001
C439, 40	ECA1HAK3R3XB	50V 3.3	2	
C441	ECBT1H104ZF5	50V 0.1U	1	F1E1H104A001
C443-48	ECBA1H101KB5	50V 100P	6	
C452, 53	ECA1HAK010XI	50V 1U	2	
C455, 56	ECA1CAK100XB	16V 10U	2	
C601	ECJ2VF1H104Z	50V 0.1U	1	
C609, 10	ECJ2VF1H104Z	50V 0.1U	2	
C612	ECJ2VF1H104Z	50V 0.1U	1	
C614	ECUV1H102KBN	50V 1000P	1	ECJ2VB1H102K
C616	RCE0JKA470BG	6.3V 47U	1	F2A0J470A014
C617	RCE1HKA3R3BG	50V 3.3U	1	F2A1H3R3A015
C618	ECUV1H180JCN	50V 18P	1	ECJ2VC1H180J
C619	ECJ2VF1H104Z	50V 0.1U	1	
C620	ECUV1H180JCN	50V 18P	1	ECJ2VC1H180J
C621, 22	ECJ2VF1H104Z	50V 0.1U	2	
C623	F2A0J102A130	6.3V 1000U	1	
C624	ECA1CAK100XB	16V 10U	1	
C625	ECUV1H102KBN	50V 1000P	1	ECJ2VB1H102K
C626, 27	ECJ2VF1H104Z	50V 0.1U	2	
C628	ECJ2VC1H101J	50V 100P	1	
C629	RCE0JKA470BG	6.3V 47U	1	F2A0J470A014
C649	ECJ2VF1H104Z	50V 0.1U	1	
C690	ECBT1H104ZF5	50V 0.1U	1	F1E1H104A001
CN201	RJT100W04	CONNECTOR (4P)	1	
CN251	RJT100W11	CONNECTOR (11P)	1	K1KA11A00093
CN253	RJT100W11	CONNECTOR (11P)	1	K1KA11A00093
CN301	RJS1A6823	CONNECTOR (23P)	1	K1MN23A00009
CN302	RJS1A6819	CONNECTOR (19P)	1	K1MN19A00013
CN601	RJS1A6223-1	CONNECTOR (23P)	1	K1MN23C00001
CN602	RJS1A6219-1	CONNECTOR (19P)	1	K1MN19C00001
CN603	RJT066H05A	CONNECTOR (5P)	1	K1KA05B000073
CP201	RJU100W04	CONNECTOR (4P)	1	
CP251	RJU100W11	CONNECTOR (11P)	1	K1KB11A000020
CP603	RJU066H05	CONNECTOR (5P)	1	K1KB05C000003
D251	MA4082LTA	DIODE	1	MAZ40820LF
D301, 02	MA165	DIODE	2	MA2C165
D303	RL1N4003N02	DIODE	1	BOAAMM000009
D304	MA4062H	DIODE	1	MAZ40620H
D307, 08	MA4091MTA	DIODE	2	MAZ40910MF
D309-12	MA719TA	DIODE	4	MA2C71900A
D315	MA4056H	DIODE	1	MAZ40560H
D320	MA29W-A	DIODE	1	MA2C029WA
D321	MA165	DIODE	1	MA2C165
D401-04	MA165	DIODE	4	MA2C165
D500	MA719TA	DIODE	1	MA2C71900A

Ref. No.	Part No.	Part Name & Description	Pcs	Remarks
D601	LNJ201LPQJA	LED	1	
D609	MA111TX	DIODE	1	MA2J11100L
D610	MA8051M	DIODE	1	MAZ80510M
D611	MA111TX	DIODE	1	MA2J11100L
D612,13	ISS380TE-17	DIODE	2	
D614	MA111TX	DIODE	1	MA2J11100L
D615	MA8062M	DIODE	1	MAZ80620ML
D622,23	MA111TX	DIODE	2	MA2J11100L
D690,91	MA719TA	DIODE	2	MA2C71900A
FL601	RSL0309-F	FL DISPLAY	1	
IC251	C1BB00000527	IC	1	
IC401	BU4053BCFE2	IC	1	
IC402	C1BB00000528	IC	1	
IC403	NJM4558MTE1	IC	1	C0ABBB000109
IC404	BU4052BCF-E2	IC	1	C0JBAR000002
IC405	NJM4558MTE1	IC	1	C0ABBB000109
IC406	BU4052BCF-E2	IC	1	C0JBAR000002
IC601	C2BBGF000286	IC	1	
JK201	SJF3069-8N	JACK, EXT IN/OUT	1	K2HA102B0039
JK301	RJT065K20	SYSTEM CONNECTOR (20P)	1	K1FA220B0006
JK302	RJT065K19	SYSTEM CONNECTOR (19P)	1	K1FA219B0001
L301,02	RLQA100JT-Y	COIL	2	G0C100JA0023
L303,04	BL02RN2R62T4	COIL	2	J0JKB0000020
L305,06	RLQ2P2R2KT-Y	COIL	2	G0C2R2KA0029
L609	RLBN300AV-W	COIL	1	J0JHC0000027
PCB1	REP3298D-M	MAIN P.C.B.	1	[RTL]
PCB2	REP3124D-S	CONTROL P.C.B.	1	[RTL]
Q251	2SC3311ATA	TRANSISTOR	1	2SC3311A0A
Q252	2SC3940AQSTA	TRANSISTOR	1	2SC3940ARA
Q301	DTC143XSTP	TRANSISTOR	1	B1GACFQH0002
Q302,03	2SC3311ATA	TRANSISTOR	2	2SC3311A0A
Q304	2SB621A-R	TRANSISTOR	1	2SB0621AH
Q305	DTC114ESTP	TRANSISTOR	1	B1GACFJJ0007
Q306	2SD2374PQAU	TRANSISTOR	1	2SD23740J1AU
Q307	2SD2137PQTA	TRANSISTOR	1	2SD21370PA
Q308	2SB1417PQTA	TRANSISTOR	1	2SB14170JA
Q311	2SA1309ATA	TRANSISTOR	1	2SA1309AWA
Q312	DTC114ESTP	TRANSISTOR	1	B1GACFJJ0007
Q313	2SC3940AQSTA	TRANSISTOR	1	2SC3940ARA
Q404	DTA114ESTP	TRANSISTOR	1	B1GCCFJJ0008
Q405,06	2SC3311ATA	TRANSISTOR	2	2SC3311A0A
Q407,08	2SD2144S	TRANSISTOR	2	
Q409	DTA114ESTP	TRANSISTOR	1	B1GCCFJJ0008
Q601	UN5214TX	TRANSISTOR	1	UNR521400L
Q602	2SD1819ATX	TRANSISTOR	1	2SD1819A0L
R207,08	ERDS2FJ103	1/4W 10K	2	
R209,10	ERDS2FJ472	1/4W 4.7K	2	
R212	ERDS2FJ100	1/4W 10	1	
R251-53	ERDS2FJ101	1/4W 100	3	
R254,55	ERDS2FJ103	1/4W 10K	2	
R256,57	ERDS2FJ101	1/4W 100	2	
R258	ERDS2FJ102	1/4W 1K	1	
R259	ERDS2FJ221	1/4W 220	1	
R260	ERDS2FJ102	1/4W 1K	1	
R261,62	ERDS2FJ103	1/4W 10K	2	
R301-03	ERDS2FJ103	1/4W 10K	3	
R304	ERDS2FJ331	1/4W 330	1	
R305	ERDS2FJ103	1/4W 10K	1	
R306	ERDS2FJ223	1/4W 22K	1	
R307	ERDS2FJ103	1/4W 10K	1	
R308,09	ERDS2FJ472	1/4W 4.7K	2	
R310	ERDS2FJ473	1/4W 47K	1	
R311	ERDS2FJ102	1/4W 1K	1	
R312	ERDS2FJ331	1/4W 330	1	

Ref. No.	Part No.	Part Name & Description	Pcs	Remarks
R313	ERDS2FJ102	1/4W 1K	1	
R314	ERDS2FJ681	1/4W 680	1	
R317,18	ERDS2FJ102	1/4W 1K	2	
R319,20	ERD2FCJ4R7	1/4W 4.7	2	
R321,22	ERDS2FJ101	1/4W 100	2	
R323	ERDS2FJ103	1/4W 10K	1	
R324	ERDS2FJ104	1/4W 100K	1	
R325,26	ERDS2FJ102	1/4W 1K	2	
R361	ERDS2FJ102	1/4W 1K	1	
R411	ERDS2FJ101	1/4W 100	1	
R413,14	ERDS2FJ101	1/4W 100	2	
R415,16	ERDS2FJ472	1/4W 4.7K	2	
R417,18	ERDS2FJ101	1/4W 100	2	
R420	ERDS2FJ152	1/4W 1.5K	1	
R421,22	ERDS2FJ101	1/4W 100	2	
R423	ERDS2FJ103	1/4W 10K	1	
R424	ERDS2FJ102	1/4W 1K	1	
R425-27	ERDS2FJ101	1/4W 100	3	
R429,30	ERDS2FJ104	1/4W 100K	2	
R431,32	ERDS2FJ101	1/4W 100	2	
R433,34	ERDS2FJ103	1/4W 10K	2	
R435,36	ERDS2FJ473	1/4W 47K	2	
R437,38	ERDS2TJ183	1/4W 18K	2	
R441,42	ERDS2FJ103	1/4W 10K	2	
R443,44	ERDS2TJ272T	1/4W 2.7K	2	
R445,46	ERDS2FJ122	1/4W 1.2K	2	
R449,50	ERDS2FJ101	1/4W 100	2	
R452	ERDS2FJ103	1/4W 10K	1	
R455	ERDS2FJ562	1/4W 5.6K	1	
R456	ERDS2T0	1/4W 0	1	ERDS2T0T
R457,58	ERDS2FJ103	1/4W 10K	2	
R459,60	ERDS2FJ562	1/4W 5.6K	2	
R461,62	ERDS2FJ104	1/4W 100K	2	
R463-65	ERDS2FJ101	1/4W 100	3	
R467,68	ERDS2FJ101	1/4W 100	2	
R469,70	ERDS2FJ223	1/4W 22K	2	
R471,72	ERDS2FJ101	1/4W 100	2	
R473,74	ERDS2FJ103	1/4W 10K	2	
R475,76	ERDS2T0	1/4W 0	2	ERDS2T0T
R477-80	ERDS2FJ103	1/4W 10K	4	
R481,82	ERDS2FJ102	1/4W 1K	2	
R483,84	ERDS2FJ332	1/4W 3.3K	2	
R485,86	ERDS2FJ102	1/4W 1K	2	
R487,88	ERDS2FJ472	1/4W 4.7K	2	
R489,90	ERDS2FJ122	1/4W 1.2K	2	
R495	ERDS2TJ105T	1/4W 1M	1	
R497	ERDS2TJ105T	1/4W 1M	1	
R501	ERDS2FJ562	1/4W 5.6K	1	
R503	ERDS2FJ102	1/4W 1K	1	
R504	ERDS2T0	1/4W 0	1	ERDS2T0T
R505	ERDS2TJ105T	1/4W 1M	1	
R506	ERDS2FJ104	1/4W 100K	1	
R507,08	ERDS2FJ102	1/4W 1K	2	
R601	ERJ6GEYJ221V	1/10W 220	1	
R602	ERJ6GEYJ821V	1/10W 820	1	
R603	ERJ6GEYJ102V	1/10W 1K	1	
R604	ERJ6GEYJ122V	1/10W 1.2K	1	D0GD122JA003
R605	ERJ6GEYJ152V	1/10W 1.5K	1	D0GD152JA003
R606	ERJ6GEYJ182V	1/10W 1.8K	1	
R607	ERJ6GEYJ222V	1/10W 2.2K	1	
R608	ERJ6GEYJ332V	1/10W 3.3K	1	D0GD332JA003
R609-14	ERJ6GEYJ331V	1/10W 330	6	
R616,17	ERJ6GEYJ331V	1/10W 330	2	
R618-20	ERJ6GEYJ103V	1/10W 10K	3	
R621	ERJ6GEYJ332V	1/10W 3.3K	1	D0GD332JA003
R622-24	ERJ6GEYJ103V	1/10W 10K	3	
R625	ERJ6GEYJ101V	1/10W 100	1	
R626-32	ERJ6GEYJ331V	1/10W 330	7	
R633	ERJ6GEYJ121V	1/10W 120	1	D0GD121JA003
R634-39	ERJ6GEYJ331V	1/10W 330	6	
R640	ERJ6GEYJ102V	1/10W 1K	1	
R641	ERJ6GEYJ103V	1/10W 10K	1	
R642,43	ERJ6GEYJ331V	1/10W 330	2	

Ref. No.	Part No.	Part Name & Description	Pcs	Remarks
R644	ERJ6GEYJ101V	1/10W 100	1	
R645	ERJ6GEYJ102V	1/10W 1K	1	
R646	ERJ6GEYJ103V	1/10W 10K	1	
R647	ERJ6GEYJ104V	1/10W 100K	1	
R648	ERJ6GEYJ102V	1/10W 1K	1	
R649	ERJ6GEY0R00V	CHIP JUMPER	1	
R650	ERJ6GEYJ103V	1/10W 10K	1	
R651	ERJ6GEYJ102V	1/10W 1K	1	
R652	ERJ6GEYJ331V	1/10W 330	1	
R653	ERJ6GEYJ223V	1/10W 22K	1	D0GD223JA003
R654	ERJ6GEYJ331V	1/10W 330	1	
R655	ERJ6GEYJ223V	1/10W 22K	1	D0GD223JA003
R656	ERJ6GEYJ331V	1/10W 330	1	
R657	ERJ6GEYG105	1/10W 1M	1	
R658	ERJ6GEYJ102V	1/10W 1K	1	
R659	ERJ6GEYJ331V	1/10W 330	1	
R660	ERJ6GEYJ101V	1/10W 100	1	
R661-63	ERJ6GEYJ331V	1/10W 330	3	
R664	ERJ6GEYJ472V	1/10W 4.7K	1	D0GD472JA012
R665	ERJ6GEYJ101V	1/10W 100	1	
R666,67	ERJ6GEYJ331V	1/10W 330	2	
R668	ERJ6GEYJ223V	1/10W 22K	1	D0GD223JA003
R669	ERJ6GEYJ101V	1/10W 100	1	
R670,71	ERJ6GEYJ151V	1/10W 150	2	
R672	ERJ6GEYJ103V	1/10W 10K	1	
R674	ERJ6GEYJ103V	1/10W 10K	1	
R675	ERJ6GEYJ101V	1/10W 100	1	
R676	ERJ6GEYJ223V	1/10W 22K	1	D0GD223JA003
R677-80	ERJ6GEYJ103V	1/10W 10K	4	
R681	ERJ6GEYJ106V	1/16W 10	1	
R682,83	ERJ6GEYF473	1/10W 47K	2	
R690	ERDS2FJ101	1/4W 100	1	
R691,92	ERDS2FJ473	1/4W 47K	2	
RJ721-24	ERJ8GEY0R00V	CHIP JUMPER	4	D0YFR0000002
S601-08	EVQ11G05R	SW,PUSH	8	
X251	RSXC4M33S02T	OSCILLATOR	1	H0H433400001
X601	RSXD32K7805	OSCILLATOR	1	H0A327200029
X602	H2B419400005	OSCILLATOR	1	
Z601	RCDGP1U26XD	REMOTE SENSOR	1	B3RAD0000010

15 Cabinet Parts Location

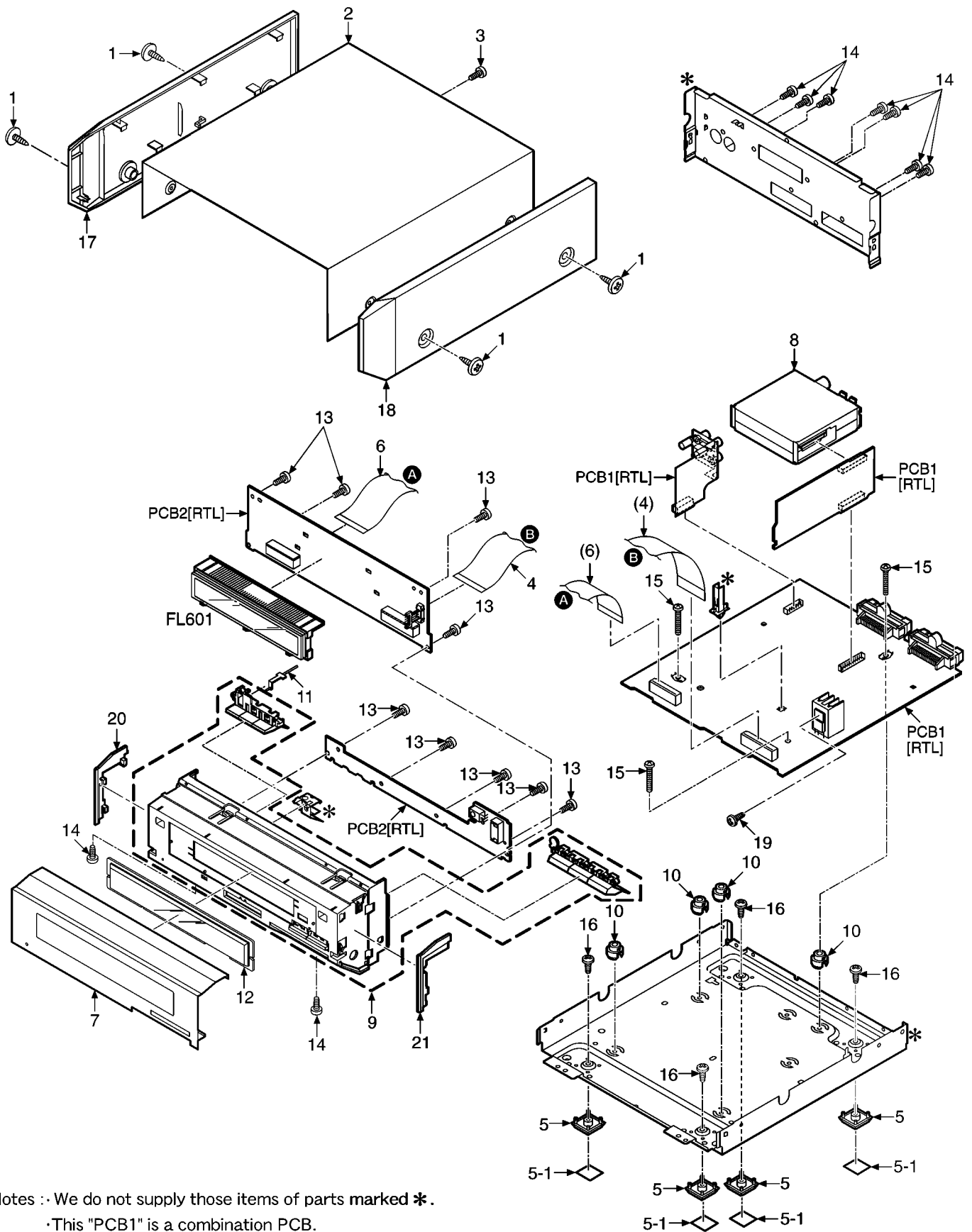

Notes :· We do not supply those items of parts marked * .
 ·This "PCB1" is a combination PCB.
 ·This "PCB2" is a combination PCB.