

Service Manual

NATIONAL
HI-FI COMPONENTS
PANASONIC



STEREO INTEGRATED AMPLIFIER

MODEL SU-3000

TECHNISCHE DATEN (Änderungen vorbehalten)

(Erfüllt Mindestanforderungen nach DIN 45 500)

Musikleistung :		2 × 25W (4 Ω)
		2 × 19W (8 Ω)
Nennleistung :		2 × 14W (4 Ω)
		2 × 12W (8 Ω)
Klirrfaktor:	Nennleistung, bei 1 kHz 4 Ω	0.8%
Leistungsbandbreite:		5~4000Hz -3dB
Eingänge	PHONO	3mV/47k Ω
	TUNER, AUX 1, 2	200mV/30k Ω
	MIC	3mV/47k Ω
Tonbandgerät:	PLAYBACK (Wiedergabe)	200mV/30k Ω
	REC OUT (Aufnahme)	200mV
REC/PLAY (Norm Buchse)	Wiedergabe	200mV/30k Ω
	Aufnahme	30mV/80k Ω

Fremdspannungsabstand :	bei Nennleistung	PHONO	60dB
		TUNER, AUX 1, 2	80dB
	bei 50mW Ausgangsleistung	PHONO	55dB
		TUNER, AUX 1, 2	55dB
Klangregler:	Tiefen-Bereich (BASS)	50 Hz, +10dB	-12dB
	Höhen-Bereich (TREBLE)	10 kHz, +10dB	-10dB
Tiefenfilter:		150 Hz, -6dB/OKT	
Höhenfilter:		6 kHz, -6dB/OKT	
Frequenzgang:		10 Hz~50.000 Hz	-3dB
Dämpfungsfaktor:			35 (8 Ω)
Max. Eingangsspannungen:	PHONO		90mV
	MIC		200mV

ALLGEMEINE DATEN

Leistungsaufnahme:	115 W
Netzspannung:	110/120/220/240V
Abmessungen (B × H × T):	336 × 115 × 295mm
Gewicht:	5.3 kg

TECHNICAL SPECIFICATIONS (Specifications are subject to change without notice.)

Music Power (IHF):		50W (4Ω)
		38W (8Ω)
RMS Power (each ch. driven):		18W/18W (4Ω)
		14W/14W (8Ω)
Harmonic Distortion:		0.8%
Intermodulation Distortion (60 Hz - 7 kHz - 4 : 1, SMPTE):		0.8%
Power Bandwidth:		5 Hz ~ 50 kHz, -3 dB
Residual Hum & Noise:		0.7 mV
Damping Factor:		35 (8 Ω)
Rated Load (MAIN or REMOTE):		4~16 Ω
Input Sensitivity & Impedance:	PHONO	3mV/47k Ω
	TUNER	200mV/30k Ω
	AUX 1, 2	200mV/30k Ω
	MIC	3mV/47k Ω
Maximum Input Voltage (1 kHz):	PHONO	90mV
	MIC	200mV
S/N (IHF, A):	PHONO	75 dB
	TUNER	96 dB
	AUX 1, 2	96 dB
	MIC	65 dB

Frequency Response:	PHONO (Deviation from RIAA standard)	±1 dB
	TUNER, AUX 1, 2	10 Hz ~ 50 kHz, ±3 dB
Tone Controls:	BASS	50 Hz, +10 dB -12 dB
	TREBLE	10 kHz, +10 dB -10 dB
Loudness Control (Volume, -30 dB):		100 Hz +10 dB, 10 kHz +5 dB
Low Filter:		150 Hz, -6 dB/oct
High Filter:		6 kHz, -6 dB/oct
Tape Monitor:	PLAYBACK	200mV/30k Ω
	REC OUT	200mV
	Input	200mV/30k Ω
	Output	30mV/80k Ω
Mixing Rec Out (Volume, Max.):		Rated Output & Impedance 1V/5k Ω

GENERAL

Power Consumption:	115 W
Power Supply:	110/120/220/240V
Dimensions (W × H × D):	17-7/32" × 4-17/32" × 11-5/8" (336 × 115 × 295mm)
Weight:	11.7 lbs. (5.3kg)



■ LOCATION OF CONTROLS

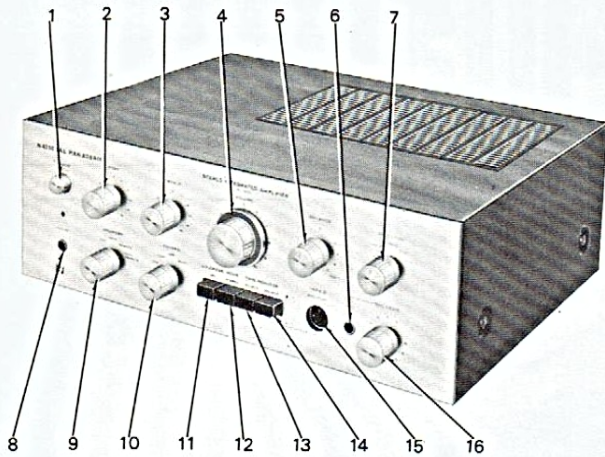

- | | |
|--------------------------|--------------------------------------|
| 1. POWER SOURCE SWITCH | 9. SPEAKERS SELECTOR SWITCH |
| 2. BASS CONTROL | 10. FILTERS SELECTOR SWITCH |
| 3. TREBLE CONTROL | 11. LOUDNESS SWITCH |
| 4. VOLUME CONTROL | 12. MODE SWITCH |
| 5. BALANCE CONTROL | 13. TAPE MONITOR [TAPE 1] SWITCH |
| 6. MICROPHONE JACK | 14. TAPE MONITOR [TAPE 2] SWITCH |
| 7. INPUT SELECTOR SWITCH | 15. TAPE MONITOR [TAPE 2] DIN SOCKET |
| 8. HEADPHONES JACK | 16. MICROPHONE LEVEL CONTROL |

- | | |
|-------------------------------------|---------------------------------------|
| 17. GROUND TERMINAL | 23. MIXING RECORDING OUTPUT TERMINALS |
| 18. INPUT TERMINALS [PHONO] | 24. CIRCUIT PROTECTION FUSES |
| 19. INPUT TERMINALS [TUNER] | 25. VOLTAGE SELECTOR SWITCH |
| 20. INPUT TERMINALS [AUX 1] | 26. MAIN SPEAKER TERMINALS |
| 21. INPUT TERMINALS [AUX 2] | 27. REMOTE SPEAKER TERMINALS |
| 22. TAPE MONITOR [TAPE 1] TERMINALS | 28. AC POWER OUTLET.....Unswitched |

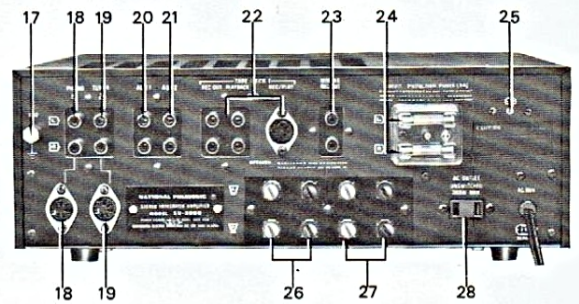

■ TO REMOVE FRONT PANEL

1. Remove the cabinet from chassis.
2. Remove eight (8) control knobs from front panel.
(Volume, balance, bass, treble, mic level control knobs and speakers, filters, selector switch knobs)
3. Remove four (4) panel mounting black screws, nos. No. 1~ No. 4 as illustrated in figure 1 and 2.
4. Remove front panel from chassis.
5. To reassemble, reverse the above procedure.

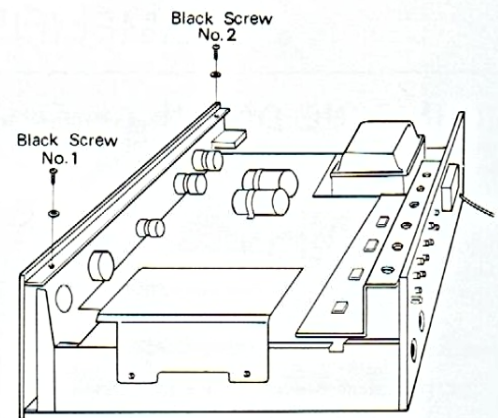

Fig. 1

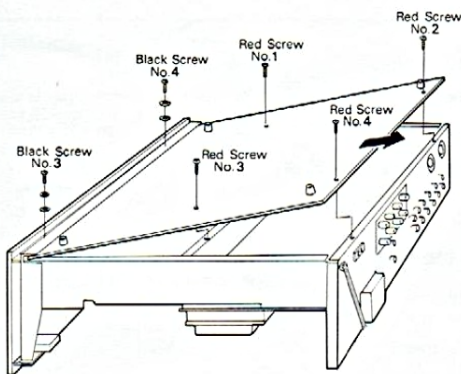

Fig. 2

■ TO REMOVE BOTTOM BOARD

1. Remove four (4) bottom board mounting red screws, nos. No. 1~ No. 4 as illustrated in figure 2.
2. Remove bottom board from chassis, as illustrated in figure 2.
3. To reassemble, reverse the above procedure.

■ ALIGNMENT INSTRUCTIONS

Notes :

1. Volume Control to Minimum.
2. Other Controls to Optional Position.
3. Before adjusting, ICQ and DC unbalance adjusting volumes (VR301, 302, 303 and 304) as right shown in Alignment Point Location.

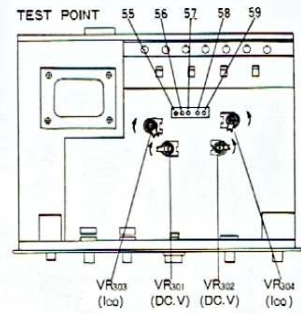

ALIGNMENT	DC VTVM CONNECTION	ADJUSTMENT	REMARKS
DC UNBALANCE	Right Channel → Connect VTVM to test point No. 57 and 58.	VR302	Make sure that VTVM becomes zero (0).
	Left Channel → Connect VTVM to test point No. 56 and 57.	VR301	
ICQ	Right Channel → Connect VTVM to test point No. 58 and 59.	VR304	Make adjustments so that the indication on VTVM becomes 3mV.
	Left Channel → Connect VTVM to test point No. 55 and 56.	VR303	

■ CABINET AND CHASSIS PARTS LOCATIONS

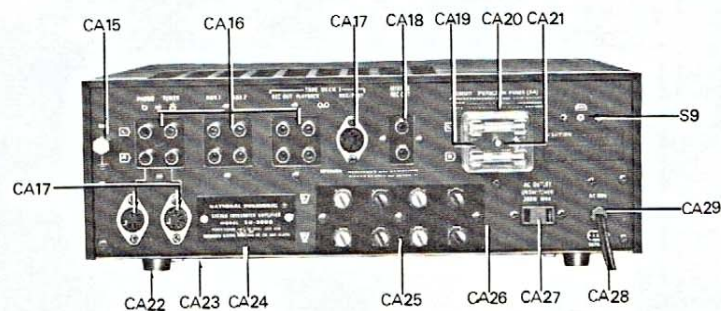
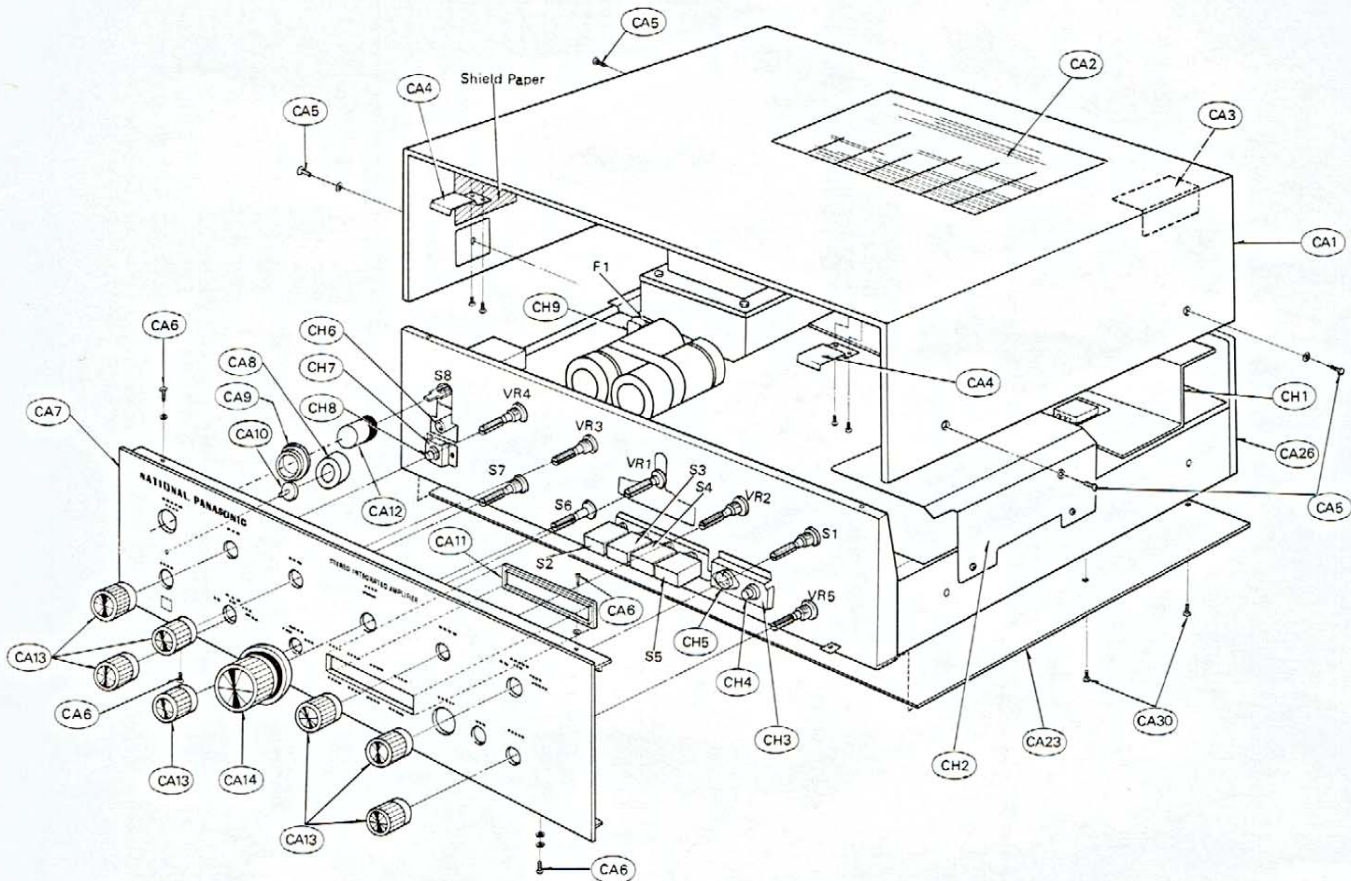

■ PACKINGS

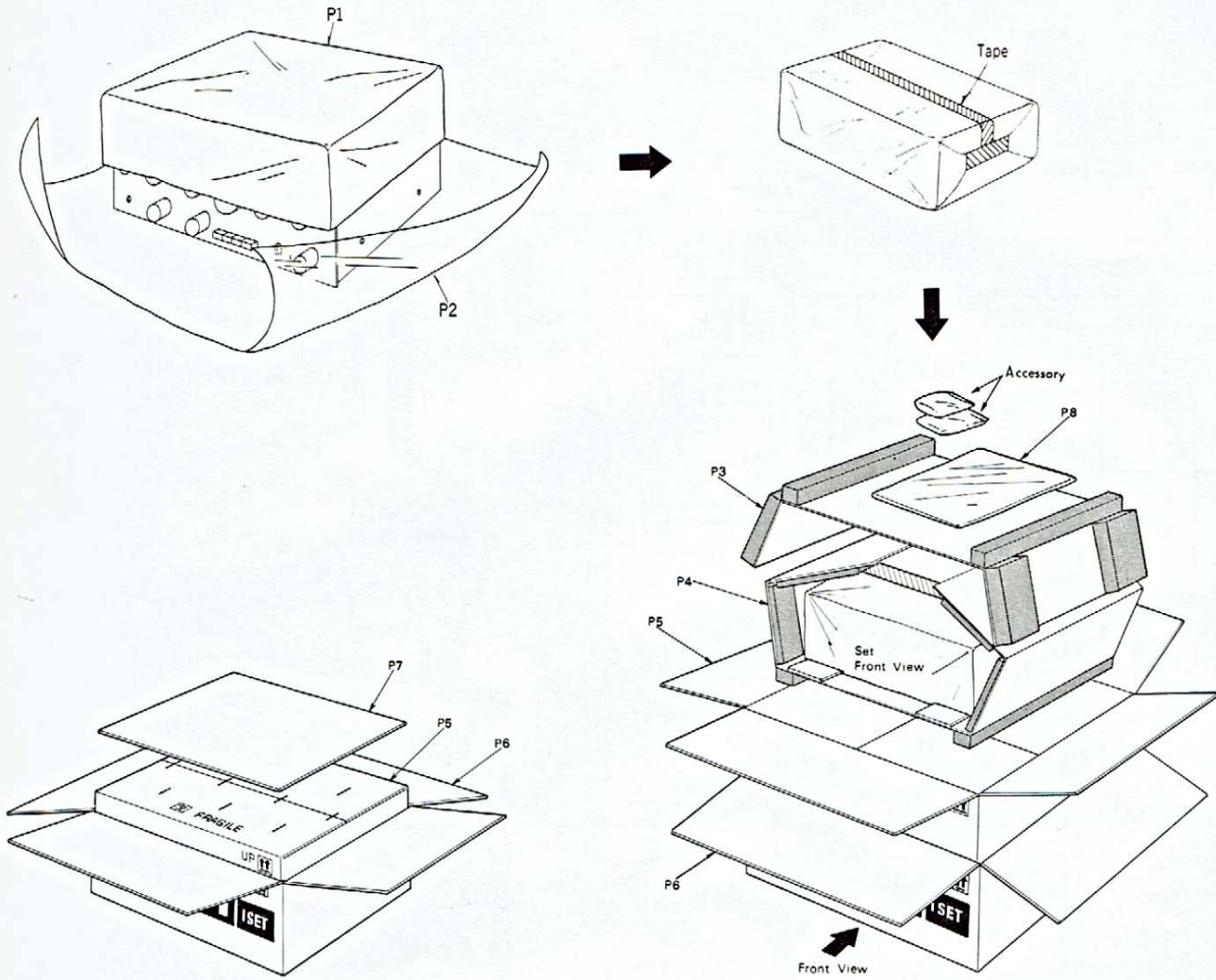

■ BLOCK DIAGRAM Tape Dubbing & MIC Circuit Only

1. S4 : Tape monitor (TAPE 1) switch in "SOURCE" position.
2. S5 : Tape monitor (TAPE 2) switch in "SOURCE" position.
3. MIC jack is not connected to MIC plug.

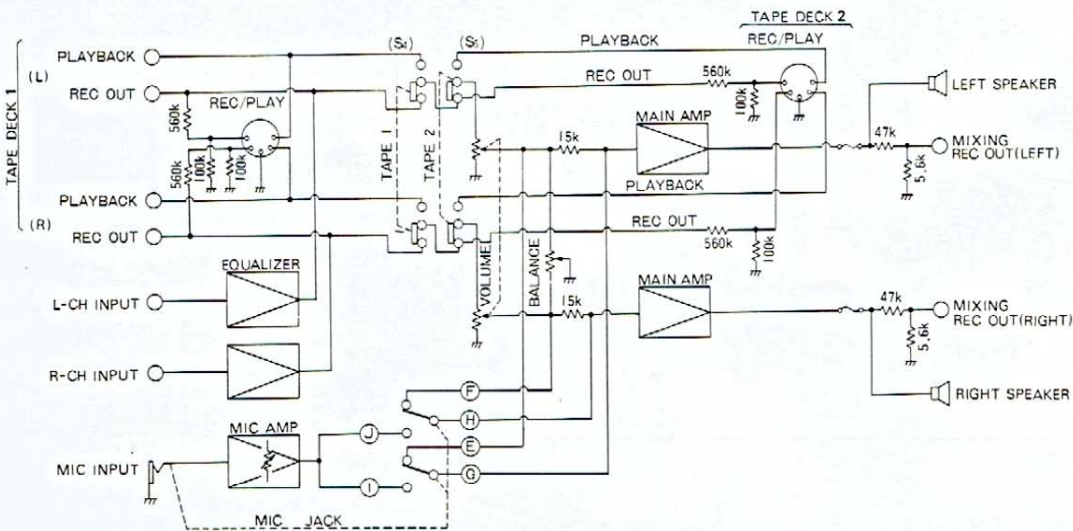

Circuit Board Wiring View Mo

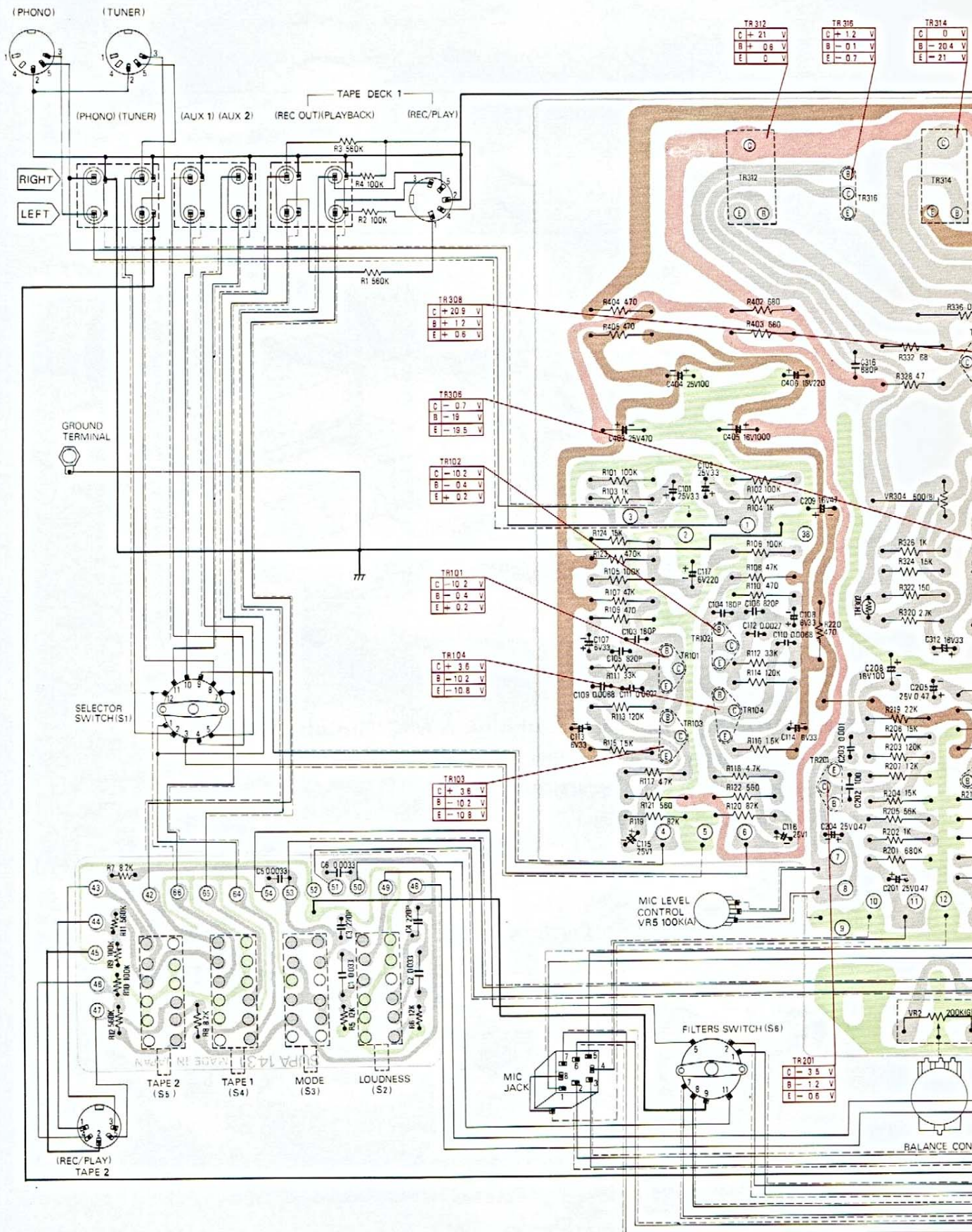

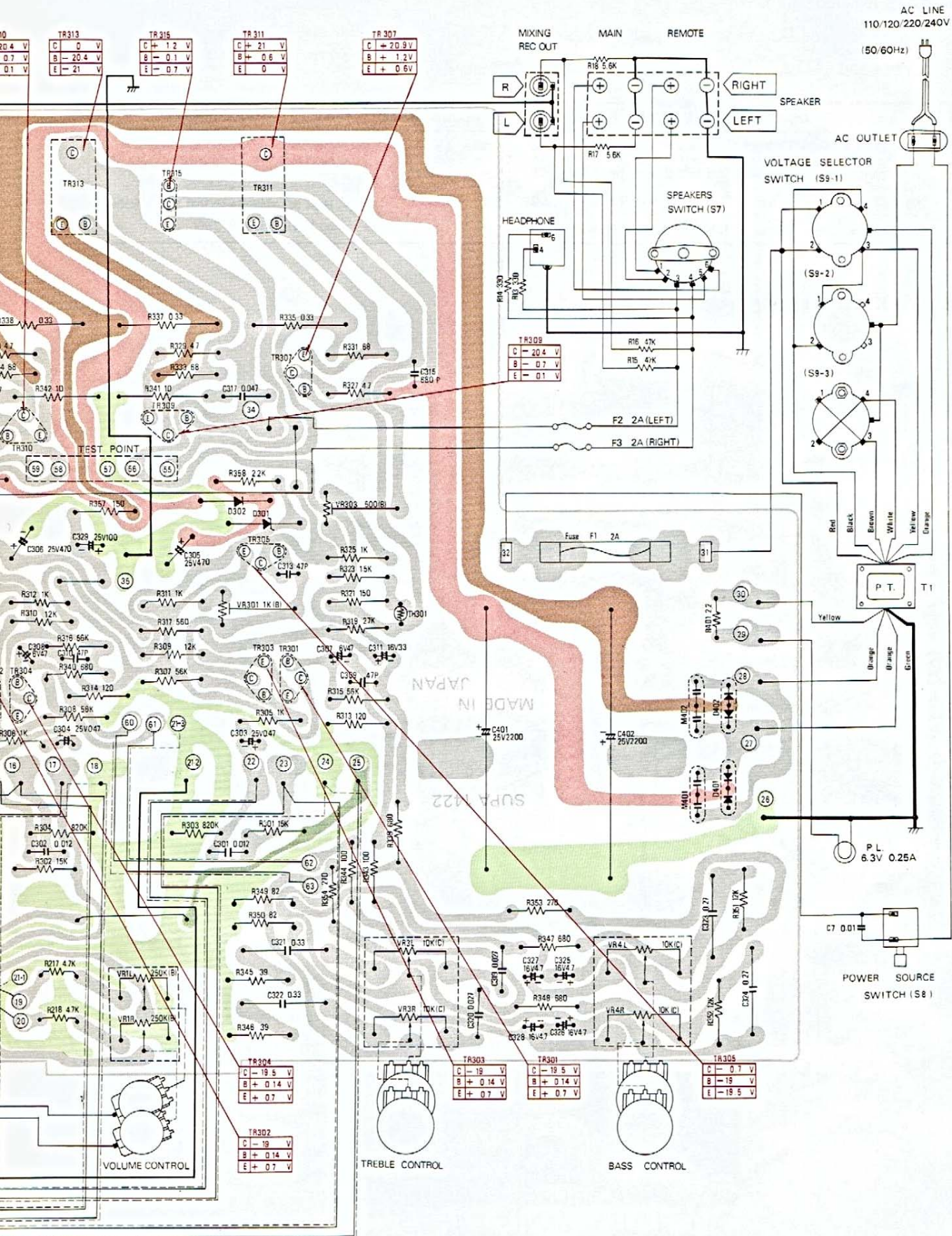

Schematic Diagram Model SU-3000

(This

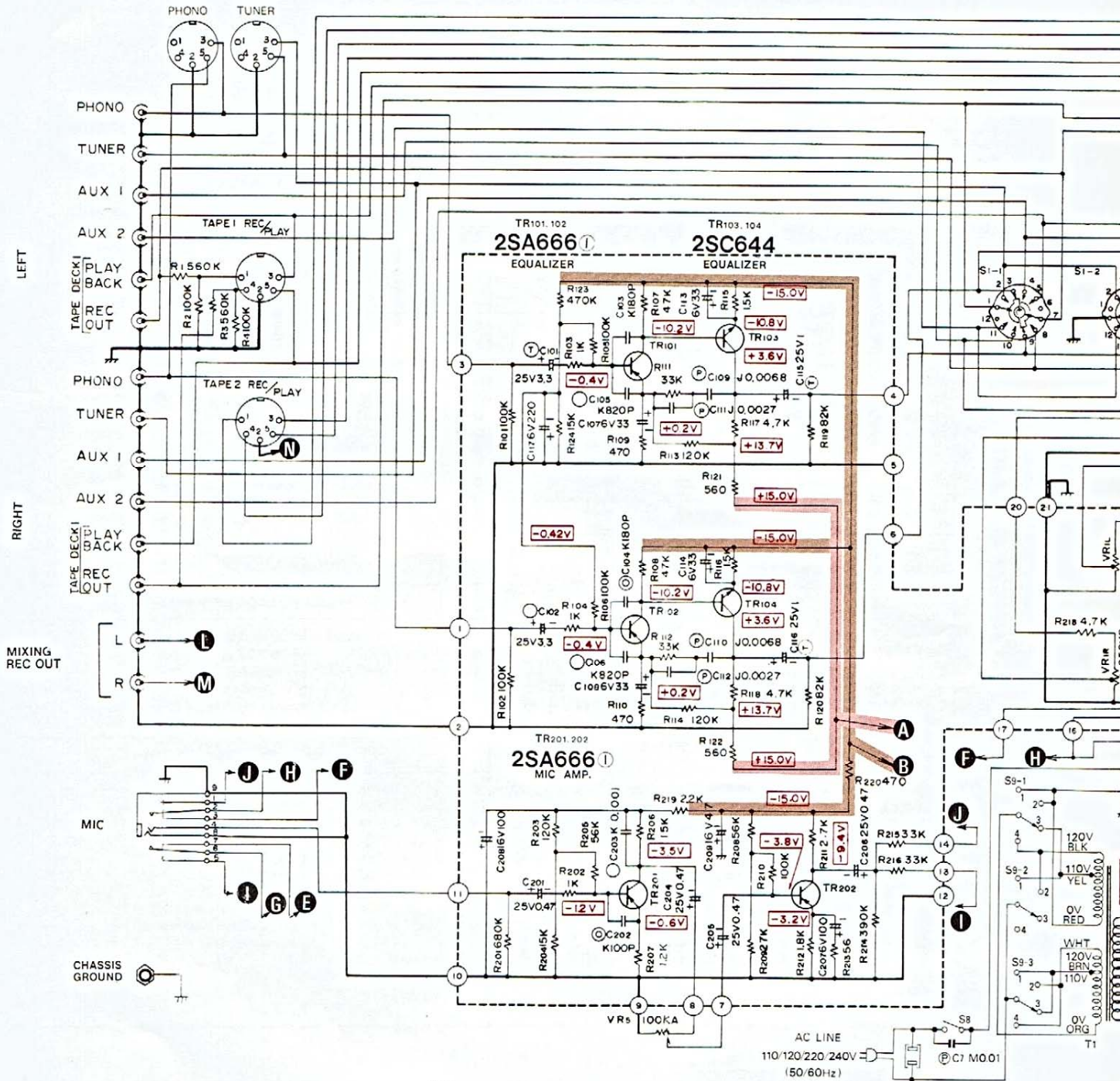

BOTTOM VIEW TOP VIEW

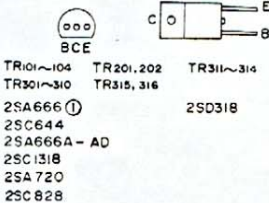

S1 SELECTOR SWITCH

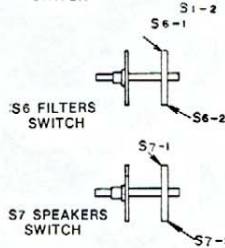

S6 FILTERS SWITCH

S7 SPEAKERS SWITCH

Notes:

- S1-1, S1-2: Input selector switch in "PHONO" position.
TUNER → PHONO → AUX 1 → AUX 2
- S2: Loudness switch in "OFF" position.
- S3: Mode switch in "STEREO" position.
- S4: Tape monitor switch (TAPE 1) in "SOURCE" position.
- S5: Tape monitor switch (TAPE 2) in "SOURCE" position.
- S6-1, S6-2: Filters selector switch in "OFF" position.
LOW → HIGH → OFF → BOTH
- S7-1, S7-2: Speakers selector switch in "MAIN" position.
OFF → MAIN → REMOTE → MAIN + REMOTE
- S8: Power source switch in "OFF" position.
- S9-1 ~ S9-3: Power source voltage selector switch in "220V" position.
110V → 120V → 220V → 240V
- DC voltage measurements are taken with VTVM from chassis ground.

- VR1L, 1R
- VR2:
- VR3L, 3R
- VR4L, 4R
- VR301, 302
- VR303, 304
- Mark
- Mark
- Mark
- Mark
- Mark

Diagram may be modified at any time with development of technology.)

⊕ B Voltage Line

⊖ B Voltage Line

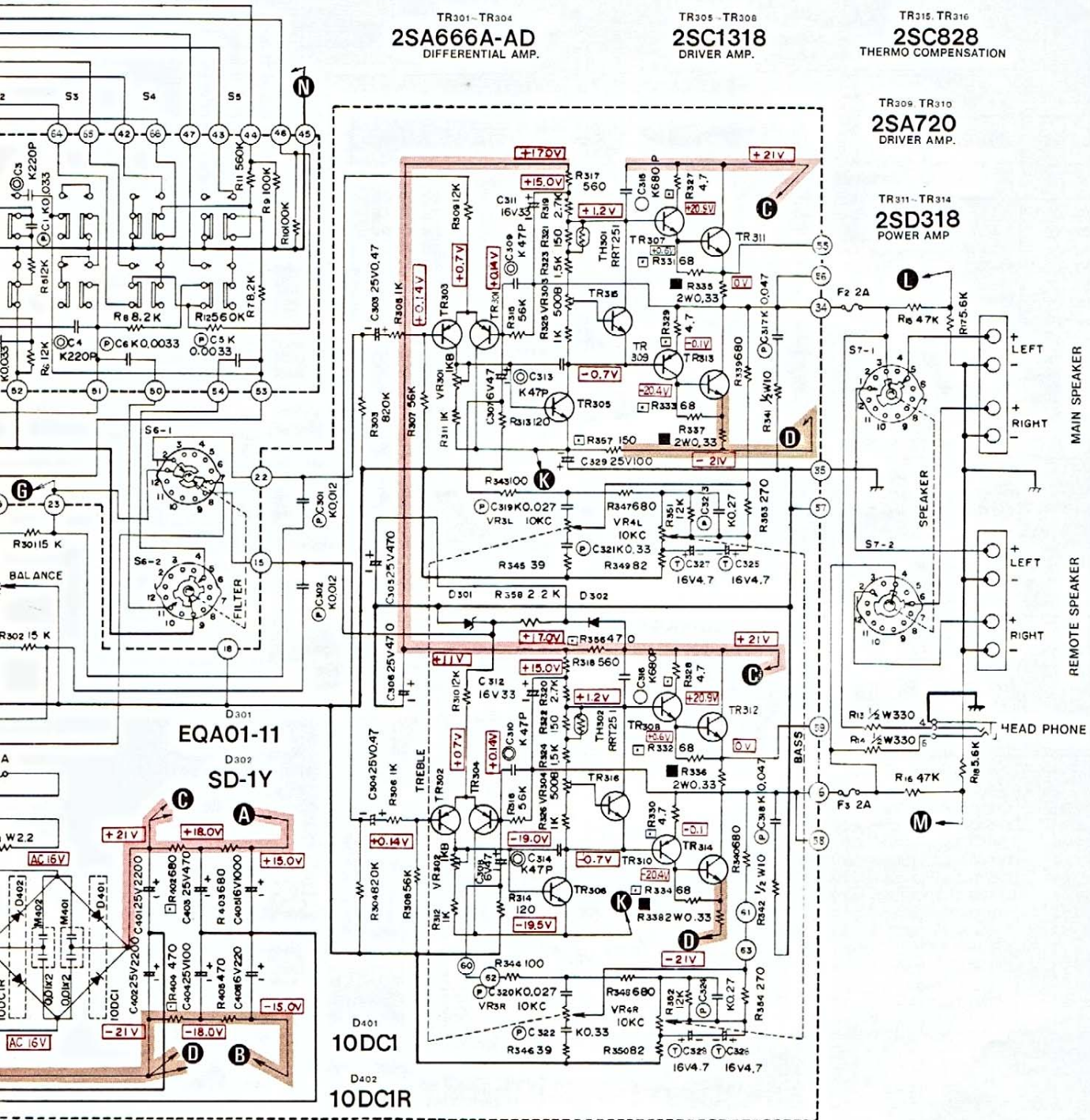

Anmerkungen:

1. S1-1, S1-2: Eingangsauswahlschalter auf "PHONO"
TUNER ↔ PHONO ↔ AUX 1 ↔ AUX 2
2. S2: Lautstärkekorrektur auf "OFF"
3. S3: Betriebsartenschalter auf "STEREO"
4. S4: Bandmonitorschalter auf "SOURCE" (TAPE 1)
5. S5: Bandmonitorschalter auf "SOURCE" (TAPE 2)
6. S6-1, S6-2: Filterschalter auf "OFF"
LOW ↔ HIGH ↔ OFF ↔ BOTH
7. S7-1, S7-2: Lautsprecherschalter auf "MAIN"
OFF ↔ MAIN ↔ REMOTE ↔ MAIN + REMOTE
8. S8: Netzschalter auf "OFF"
9. S9-1 ~ S9-3: Netzwähler auf "220V"
110V ↔ 120V ↔ 220V ↔ 240V
10. Gleichspannungsmessungen erfolgen mit Röhrevoltmeter in bezug auf Chassispotential.

REPLACEMENT PARTS LIST

NOTES:

- Part numbers are indicated on most mechanical parts. Please use this part number, for parts orders.
- N indicates the New Parts.
- X-Z rank: X rank parts will cover 80% of repair needs.
X+Y rank parts will cover 95% of repair needs.
Z rank parts are less necessary.

Bemerkungen:

- Die meisten mechanischen Teile sind mit Teilnummern versehen. Bitte geben Sie diese Nummern an, sofern die Teile keine Bezugsnummern haben.
- N bedeutet: Neue Teile.
- Gruppen X-Z: Teile der Gruppe X machen 80% des Ersatzteilbedarfes aus. Teile der Gruppen X und Y machen 95% des Ersatzteilbedarfes aus. Teile der Gruppe Z werden seltener benötigt.

Ref. No.	Part No.	Description	Per Set (Pcs.)	Remarks	Ref. No.	Part No.	Description	Per Set (Pcs.)	Remarks
TRANSISTORS									
TR101, 102, 201, 202	2SA666 I-R.S	Equalizer & Mic Amplifier	4	X	R113, 114, 203	ERD14T J124	120kΩ, 1/4W, ± 5%, Carbon	3	Y
TR103, 104	2SC644R S	Equalizer Amplifier	2	X	R214	ERD14T J394	390kΩ, 1/4W, ± 5%, Carbon	1	Y
TR301, 302, 303, 304	2SA666A-AD1 ~AD5	Differential Amplifier [Use in pairs]	4	X	R123	ERD14T J474	470kΩ, 1/4W, ± 5%, Carbon	1	Y
TR305, 306, 307, 308	2SC1318R.Q	Pre Driver & Driver Amplifier [Use in pairs]	4	X	R1, 3	ERD14T J564	560kΩ, 1/4W, ± 5%, Carbon	2	Y
TR309, 310	2SA720R.Q	Driver Amplifier	2	X	R201	ERD14T J684	680kΩ, 1/4W, ± 5%, Carbon	1	Y
TR311, 312, 313, 314	2SD318Q.P	Power Amplifier [Use in pairs]	4	X	R303, 304	ERD14T J824	820kΩ, 1/4W, ± 5%, Carbon	2	Y
TR315, 316	2SC828Q.R.S	Thermo Compensation	2	X	R217, 218	ERD14V J472	4.7kΩ, 1/4W, ± 5%, Carbon	2	Y
TRANSFORMER									
T1	SLTA5N8S-W	Power Transformer	1	N X	R7, 8	ERD14V J822	8.2kΩ, 1/4W, ± 5%, Carbon	2	Y
DIODES									
D301	SVDEQA01-11R	Zener, 11V, Noise Canceler	1	X	R5, 6	ERD14V J123	12kΩ, 1/4W, ± 5%, Carbon	2	Y
D302	RVDS0-1Y	Noise Canceler	1	X	R9, 10	ERD14V J104	100kΩ, 1/4W, ± 5%, Carbon	2	Y
D401	RVD10DC1	Rectifier	1	X	R11, 12	ERD14V J564	560kΩ, 1/4W, ± 5%, Carbon	2	N Y
D402	RVD10DC1R	Rectifier	1	X	R327, 328, 329, 330	ERD14F J4R7	4.7Ω, 1/4W, ± 5%, Carbon	4	Y
RESISTORS									
R345, 346	ERD14T J390	39Ω, 1/4W, ± 5%, Carbon	2	Y	R331, 332, 333, 334	ERD14F J680	68Ω, 1/4W, ± 5%, Carbon	4	Y
R213	ERD14T J560	56Ω, 1/4W, ± 5%, Carbon	1	Y	R357	ERD14F J151	150Ω, 1/4W, ± 5%, Carbon	1	Y
R349, 350	ERD14T J820	82Ω, 1/4W, ± 5%, Carbon	2	Y	R356, 404	ERD14F J471	470Ω, 1/4W, ± 5%, Carbon	2	Y
R343, 344	ERD14T J101	100Ω, 1/4W, ± 5%, Carbon	2	Y	R402	ERD14F J681	680Ω, 1/4W, ± 5%, Carbon	1	Y
R313, 314	ERD14T J121	120Ω, 1/4W, ± 5%, Carbon	2	Y	R341, 342	ERD12T J100	10Ω, 1/2W, ± 5%, Carbon	2	Y
R321, 322	ERD14T J151	150Ω, 1/4W, ± 5%, Carbon	2	Y	R13, 14	ERD12T J331	330Ω, 1/2W, ± 5%, Carbon	2	Y
R353, 354	ERD14T J271	270Ω, 1/4W, ± 5%, Carbon	2	Y	R401	ERD18F J2R2	2.2Ω, 1/8W, ± 5%, Carbon	1	Y
R109, 110, 220, 405	ERD14T J471	470Ω, 1/4W, ± 5%, Carbon	4	Y	R335, 336, 337, 338	ERX2ANKR33	0.33Ω, 2W, ± 10%, Metallic	4	Y
R121, 122, 317, 318	ERD14T J561	560Ω, 1/4W, ± 5%, Carbon	4	Y	VARIABLE RESISTORS				
R339, 340, 347, 348, 403	ERD14T J681	680Ω, 1/4W, ± 5%, Carbon	5	Y	VR1L, 1R	SVVAKA30BF5	250kΩ (B), Volume Control	1	N X
R103, 104, 202, 305, 306, 311, 312, 325, 326	ERD14T J102	1kΩ, 1/4W, ± 5%, Carbon	9	Y	VR2	EVE24AU30G25	200kΩ (G), Balance Control	1	X
R207	ERD14T J122	1.2kΩ, 1/4W, ± 5%, Carbon	1	Y	VR3L, 3R, 4L, 4R	EVFNTAU30C14	10kΩ (C), Treble & Bass Control	2	X
R115, 116, 323, 324	ERD14T J152	1.5kΩ, 1/4W, ± 5%, Carbon	4	Y	VR5	EVHB8A432A15	100kΩ (A), Mic Level Control	1	X
R212	ERD14T J182	1.8kΩ, 1/4W, ± 5%, Carbon	1	Y	VR301, 302	EVL33AA00B13	1kΩ (B), DC Unbalance Adjustment	2	X
R219, 358	ERD14T J222	2.2kΩ, 1/4W, ± 5%, Carbon	2	Y	VR303, 304	EVL33AA00B52	500Ω (B), ICQ Adjustment	2	X
R211, 319, 320	ERD14T J272	2.7kΩ, 1/4W, ± 5%, Carbon	3	Y	CAPACITORS				
R117, 118	ERD14T J472	4.7kΩ, 1/4W, ± 5%, Carbon	2	Y	C309, 310, 313, 314	ECCD1H470K	47pF, 50WV, ± 10%, Ceramic	4	Z
R17, 18	ERD14T J562	5.6kΩ, 1/4W, ± 5%, Carbon	2	Y	C202	ECCD1H101K	100pF, 50WV, ± 10%, Ceramic	1	Z
R309, 310, 351, 352	ERD14T J123	12kΩ, 1/4W, ± 5%, Carbon	4	Y	C103, 104	ECCD1H181K	180pF, 50WV, ± 10%, Ceramic	2	Z
R124, 204, 206, 301, 302	ERD14T J153	15kΩ, 1/4W, ± 5%, Carbon	5	Y	C3, 4	ECCD1H221K	220pF, 50WV, ± 10%, Ceramic	2	Z
R209	ERD14T J273	27kΩ, 1/4W, ± 5%, Carbon	1	Y	C315, 316	ECKD2H681KE	680pF, 500WV, ± 10%, Ceramic	2	Z
R111, 112, 215, 216	ERD14T J333	33kΩ, 1/4W, ± 5%, Carbon	4	Y	C105, 106	ECKD2H821KB	820pF, 500WV, ± 10%, Ceramic	2	Z
R15, 16, 107, 108	ERD14T J473	47kΩ, 1/4W, ± 5%, Carbon	4	Y	C203	ECKD1H102PF	0.001μF, 50WV, ± 10%, Ceramic	1	Z
R205, 208, 307, 308, 315, 316	ERD14T J563	56kΩ, 1/4W, ± 5%, Carbon	6	Y	C301, 302	ECQM05123KZ	0.012μF, 50WV, ± 10%, Polyester	2	Z
R119, 120	ERD14T J823	82kΩ, 1/4W, ± 5%, Carbon	2	Y	C319, 320	ECQM05273KZ	0.027μF, 50WV, ± 10%, Polyester	2	Z
R2, 4, 101, 102, 105, 106, 210	ERD14T J104	100kΩ, 1/4W, ± 5%, Carbon	7	Y	C1, 2	ECQM05333KZ	0.033μF, 50WV, ± 10%, Polyester	2	Z
TRANSISTORS									
R113, 114, 203	ERD14T J124	120kΩ, 1/4W, ± 5%, Carbon	3	Y	C317, 318	ECQM05473KZ	0.047μF, 50WV, ± 10%, Polyester	2	Z
R214	ERD14T J394	390kΩ, 1/4W, ± 5%, Carbon	1	Y	C323, 324	ECQM05274KZ	0.27μF, 50WV, ± 10%, Polyester	2	Z
R123	ERD14T J474	470kΩ, 1/4W, ± 5%, Carbon	1	Y	C321, 322	ECQM05334KZ	0.33μF, 50WV, ± 10%, Polyester	2	Z
R1, 3	ERD14T J564	560kΩ, 1/4W, ± 5%, Carbon	2	Y	C7	ECQU2A103MD	0.01μF, 250WV, ± 20%, Polyester	1	Z
R201	ERD14T J684	680kΩ, 1/4W, ± 5%, Carbon	1	Y	C111, 112	ECQG05272JZN	0.0027μF, 50WV, ± 5%, Polyester	2	Z
R303, 304	ERD14T J824	820kΩ, 1/4W, ± 5%, Carbon	2	Y	C5, 6	ECQG05332JZN	0.0033μF, 50WV, ± 5%, Polyester	2	Z
R217, 218	ERD14V J472	4.7kΩ, 1/4W, ± 5%, Carbon	2	Y	C109, 110	ECQG05682JZN	0.0068μF, 50WV, ± 5%, Polyester	2	Z
R7, 8	ERD14V J822	8.2kΩ, 1/4W, ± 5%, Carbon	2	Y	C201, 204, 205, 206, 303, 304	ECAG25ER47X	0.47μF, 25WV, Electrolytic	6	Y
R5, 6	ERD14V J123	12kΩ, 1/4W, ± 5%, Carbon	2	Y	C325, 326, 327, 328	ECSZ16EF4R7M	4.7μF, 16WV, Electrolytic	4	Y
R9, 10	ERD14V J104	100kΩ, 1/4W, ± 5%, Carbon	2	Y	C101, 102	ECSZ25EF3R3B	3.3μF, 25WV, Electrolytic	2	Y
R11, 12	ERD14V J564	560kΩ, 1/4W, ± 5%, Carbon	2	Y	C115, 116	ECSZ25EF1B	1μF, 25WV, Electrolytic	2	Y
R327, 328, 329, 330	ERD14F J4R7	4.7Ω, 1/4W, ± 5%, Carbon	4	Y	C107, 108, 113, 114	ECEA6V33	33μF, 6.3WV, Electrolytic	4	Y
R331, 332, 333, 334	ERD14F J680	68Ω, 1/4W, ± 5%, Carbon	4	Y	C307, 308	ECEA6V47	47μF, 6.3WV, Electrolytic	2	Y
R357	ERD14F J151	150Ω, 1/4W, ± 5%, Carbon	1	Y	C207	ECEA6V100	100μF, 6.3WV, Electrolytic	1	Y
R356, 404	ERD14F J471	470Ω, 1/4W, ± 5%, Carbon	2	Y	C117	ECEA6V220	220μF, 6.3WV, Electrolytic	1	Y
R402	ERD14F J681	680Ω, 1/4W, ± 5%, Carbon	1	Y	C311, 312	ECEA16V33	33μF, 16WV, Electrolytic	2	Y
R341, 342	ERD12T J100	10Ω, 1/2W, ± 5%, Carbon	2	Y	C209	ECEA16V47	47μF, 16WV, Electrolytic	1	Y
R13, 14	ERD12T J331	330Ω, 1/2W, ± 5%, Carbon	2	Y					
R401	ERD18F J2R2	2.2Ω, 1/8W, ± 5%, Carbon	1	Y					
R335, 336, 337, 338	ERX2ANKR33	0.33Ω, 2W, ± 10%, Metallic	4	Y					

Ref. No.	Part No.	Description	Per Set (Pcs.)	Remarks	Ref. No.	Part No.	Description	Per Set (Pcs.)	Remarks
C208	ECEA16V100	100 μ F, 16WV, Electrolytic	1	Y	CA16	SJFA3407	Terminal, Input & Tape Monitor	3	Z
C406	ECEA16V220	220 μ F, 16WV, Electrolytic	1	Y	CA17	RJS31-1	DIN Socket, Tape Monitor, Phono & Tuner	3	Z
C405	ECEA16V1000	1000 μ F, 16WV, Electrolytic	1	Y	CA18	SJFA3203	Terminal, Mixing Rec Out	1	Z
C329, 404	ECEA25V100	100 μ F, 25WV, Electrolytic	2	Y	CA19	SJFA5201	Terminal, Circuit Protection Fuses	1	Z
C305, 306, 403	ECEA25V470	470 μ F, 25WV, Electrolytic	3	Y	CA20	SJFA5202	Cap, Circuit Protection Fuses Terminal	1	Y
C401, 402	ECEB25V2200	2200 μ F, 25WV, Electrolytic	2	Y	CA21	XSN26+12	Screw, Circuit Protection Fuses Cap M'tg	1	Z
THERMISTORS and COMPONENT COMBINATIONS					CA22	SYUA20C	Bottom Board(Complete)	1	N Z
TH301, 302	RRT251	Thermistor, Driver Circuit	2	Y	CA23	SHG309	Leg	(4)	Z
M401, 402	RXAF103P22HD	Couplet, 0.01 μ F, 500WV, Rectifier Circuit	2	Y	CA24	SKUA280-1	Bottom Board Only	(1)	Z
SWITCHES					CA25	SGTA1310	Name Plate	1	N Z
S1-1, 1-2	SSRA24	Input Selector Switch	1	N X	CA26	SJFA4802	Terminal, Speakers	1	Z
S2, 3, 4, 5	SSHA404	Loudness, Mode, Tape 1, 2 Switches } Complete	1	N X	CA27	SGPA211A	Rear Panel	1	N Z
	SBCA42	Button, Push Switches [Order SSHA404]	(4)		CA27	SJSA1	Socket, AC Power Source	1	Z
S6-1, 6-2	SSRA25	Filters Switch	1	N X	CA28	SJAA3	Cord, AC Power Source	1	Y
S7-1, 7-2	SSRA23	Speaker Selector Switch	1	X	CA29	RHR111	Bushing, AC Cord	1	Z
S8	SSHA15S	Power Source Switch	1	X	CA30	XTB4+88R	Screw, Bottom Board M'tg.	4	Z
S9-1-9-3	SSRA7S	Power Source Voltage Selector Switch	1	X	CHASSIS PARTS				
FUSES and LIGHT					CH1	SMYA25-1	Heat Sink	1	N Z
F1	XBA1E20NR5	Fuse, Power Source	1	X	CH2	SMCA78	Plate,Shield	1	N Z
F2, 3	XBAS1A2001	Fuse, Circuit Protection	2	X	CH3	SMKA1	Mounting, Mic & Tape Monitor 2 Socket	1	N Z
PL	XAM35K	Light, Power Indicator	1	X	CH4	SJJA10	Jack, Microphone	1	Y
CABINET PARTS					CH5	SJSA2	Socket, Tape Monitor 2	1	N Z
CA1	SKAA580	Cabinet (Complete)	1	N Y	CH6	RMZ11A	Bracket, Pilot Lamp	1	Z
CA2	SKMA150	Cabinet Only	(1)		CH7	RJV1A	Holder, Pilot Lamp	1	Z
CA3	SKNA1	Hole, Ventilation	(1)		CH8	SMKA2	Mounting, Headphones Jack	1	N Z
CA4	SKW43-1	Mounting, Cabinet	(1)		CH9	SJJA8	Jack, Headphones	1	Y
CA5	SKYA2	Mounting, Cabinet	(2)			RJF107-2	Holder, Fuse, Power Supply p. c. b. 5 Pin Terminal, Test Point in p.c.b.	2	Z
CA6	XSB4+12BVCS	Screw, Cabinet M'tg.	4	Z				1	Z
CA7	XSB3+6KS	Screw, Panel M'tg.	4	Z	ACCESSORIES				
CA8	SYWSU3000XG1	Front Panel (Complete)	1	N Z	A1	RJP16AS	Plug, AC Power Source	1	Y
CA9	SGWA1010	Front Panel	(1)	N Z	A2	RJP17AS	Plug, AC Power Source	1	Y
CA10	SHRA601	Cover, Light	(1)	Z	A3	XBAS1A2001	Fuse, Circuit Protection	4	X
CA11	SGX6002	Bracket, Power Source Switch	(1)	Z	PACKING PARTS				
CA12	SGLA5-1	Indicator, Power ON-OFF	(1)	Z	P1	SPPA26	Soft Cover	1	N Z
CA13	SGXA6006	Bracket, Push Switches	(1)	N Z	P2	SPEA3	Cover, AC Plug	1	Z
CA14	SBCA34	Button, Power Source Switch	1	X	P3	SPHA1	Polyethylene Sheet	1	N Z
CA15	SBNA92	Knob, Balance, Bass, Treble, Mic Controls & Input, Speaker, Filter Switches	7	N X	P4	SPSA35	Pad, Upper	1	N Z
					P5	SPSA34	Pad, Lower	1	N Z
					P6	SPNA90A	Carton Box, Inner	1	N Z
					P7	SPGA42A	Carton Box, Outer	1	N Z
					P8	SPSA36	Pad, Inner Carton Box	1	N Z
						SQFA137	Printed Matter (Complete)	1	N Y
						SQXA5087	Instructions Book(Order SQFA137)	(1)	

ACCESSORIES

