

Service Manual

SU-9011/K

Stereo Preamplifier

SU-9011

(E), (EG), (X), (XA),
(XE), (XGF), (XGH)

SU-9011K

(E), (EG), (XGH)



SU-9011

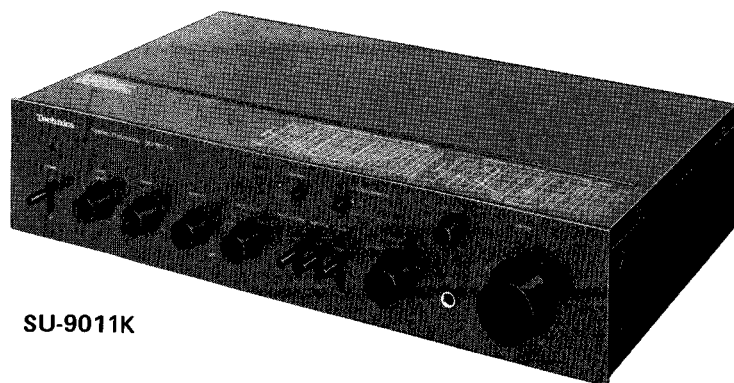

SU-9011K

- * The models SU-9011 (E, EG) and SU-9011K (E, EG) are available in Scandinavia and European only.
- * The models SU-9011 (X) and SU-9011 (XA) are available in Asia, Latin America, Middle East and Africa only.
- * The model SU-9011 (XE) is available in United Kingdom only.
- * The model SU-9011 (XGF) is available in France only.
- * The models SU-9011 (XGH) and SU-9011K (XGH) are available in Holland only.

TECHNICAL SPECIFICATIONS (Specifications are subject to change without notice for further improvement.)

(DIN 45 500)

AMPLIFIER SECTION

Input sensitivity & impedance	
PHONO 1 MC	70 μ V/10 Ω
PHONO 1 MM, PHONO 2	2.5 mV/47 k Ω
TUNER, AUX	150 mV/47 k Ω
TAPE 2 (PLAYBACK)	150 mV/47 k Ω
TAPE 1 (PLAYBACK), REC/PLAY (input)	180 mV/47 k Ω
MIC	4 mV/10 k Ω
Phono maximum input voltage (1 kHz, RMS)	
PHONO 1 MC	6 mV
PHONO 1 MM, PHONO 2	200 mV
MIC maximum input voltage (1 kHz, RMS)	
	100 mV (T.H.D. 0.05%)
Rated total harmonic distortion	0.008%
S/N	
rated output	
PHONO 1 MC	62 dB (IHF, A: 69 dB)
PHONO 1 MM, PHONO 2	75 dB (IHF, A: 88 dB)
TUNER, AUX	
	85 dB (IHF, A: 100 dB)
MIC	65 dB (IHF, A: 73 dB)
-26 dB output	
PHONO 1 MC	60 dB
PHONO 1 MM, PHONO 2	62 dB
TUNER, AUX	63 dB
MIC	60 dB
Frequency response	
PHONO 1, 2 (30 Hz ~ 15 kHz)	
	RIAA standard curve \pm 0.2 dB
TUNER, AUX	20 Hz ~ 20 kHz, +0, -0.2 dB
	5 Hz ~ 40 kHz, -1 dB
MIC	20 Hz ~ 45 kHz, +0, -3 dB

Total harmonic distortion (20 Hz ~ 20 kHz)

PHONO 1 MC 1 V output (volume at -20 dB) 0.02%
3 V output (volume at 0 dB) 0.03%

PHONO 1 MM, PHONO 2
1 V output (volume at -20 dB) 0.01%
3 V output (volume at 0 dB) 0.008%

TUNER, AUX
1 V output (volume at -20 dB) 0.008%
3 V output (volume at 0 dB) 0.005%

Tone control

Bass 50 Hz, +8 dB ~ -8 dB

Treble 20 kHz, +8 dB ~ -8 dB

Subsonic filter

30 Hz, -12 dB/oct

High filter

7 kHz, -6 dB/oct

Loudness control (volume at -30 dB)

50 Hz +9 dB

Output voltage & impedance

OUTPUT, MIXING REC OUT rated 1 V/600 Ω

maximum 5 V/600 Ω

TAPE 1, 2 (REC OUT) 150 mV

REC/PLAY (output) 30 mV/82 k Ω

Channel separation, AUX 1 kHz

53 dB

GENERAL

Power consumption 16 W

Power supply AC 50/60 Hz, 110, 120, 220, 240 V

Dimensions (W x H x D) 430 x 98 x 285 mm

(16% x 3% x 11% inch)

Weight 4.8 kg (10.6 lb)

LOCATION OF CONTROLS

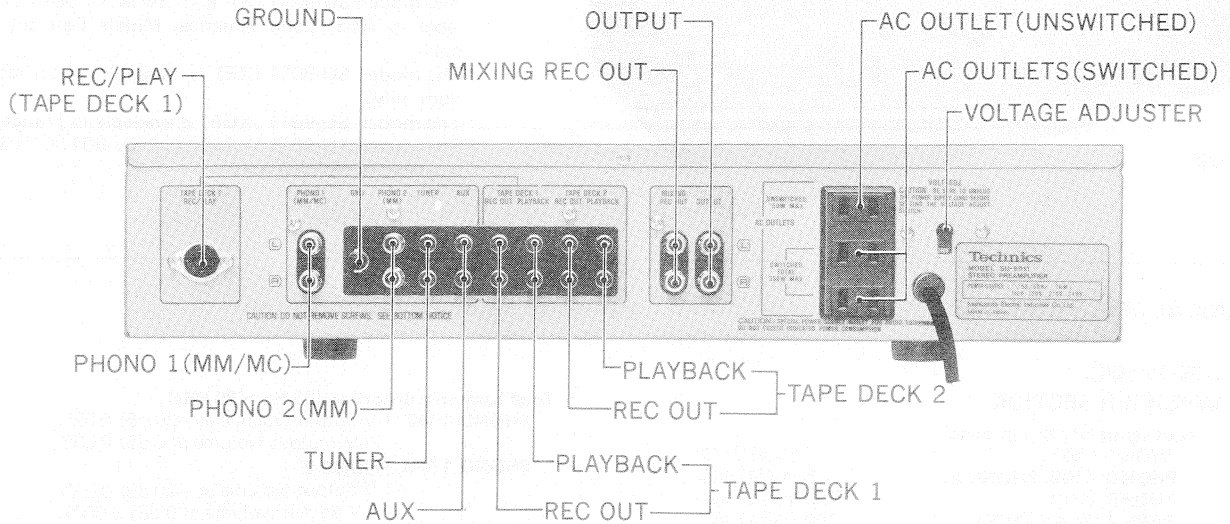
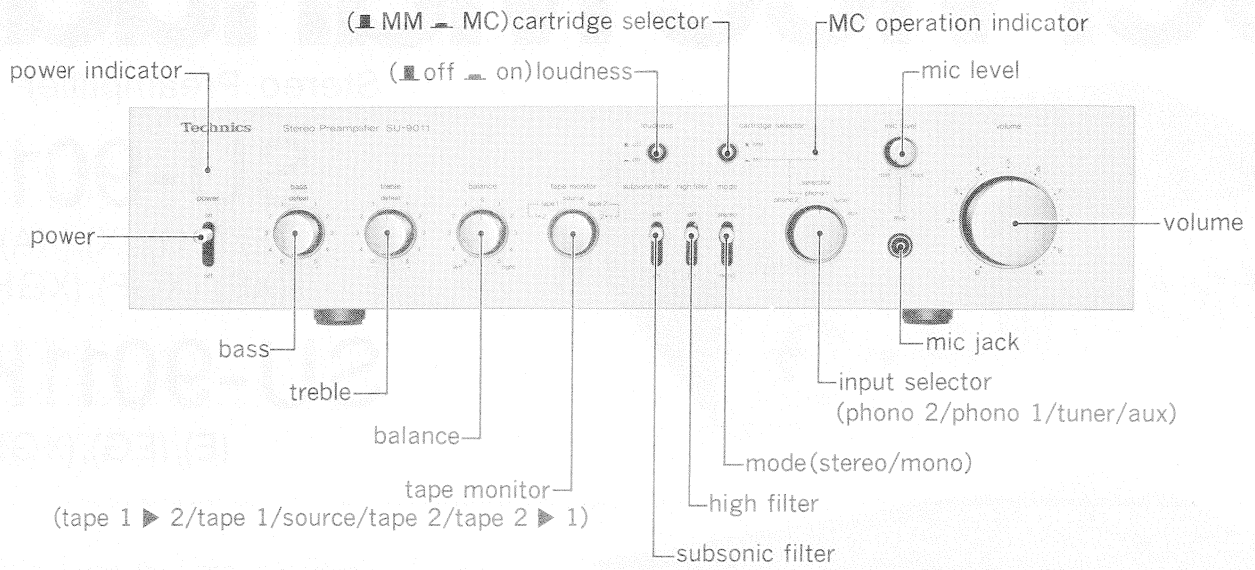

* This photo shows only the products for (X) and (XA).

* The products for other destinations except (X) and (XA) are not equipped with AC outlets.

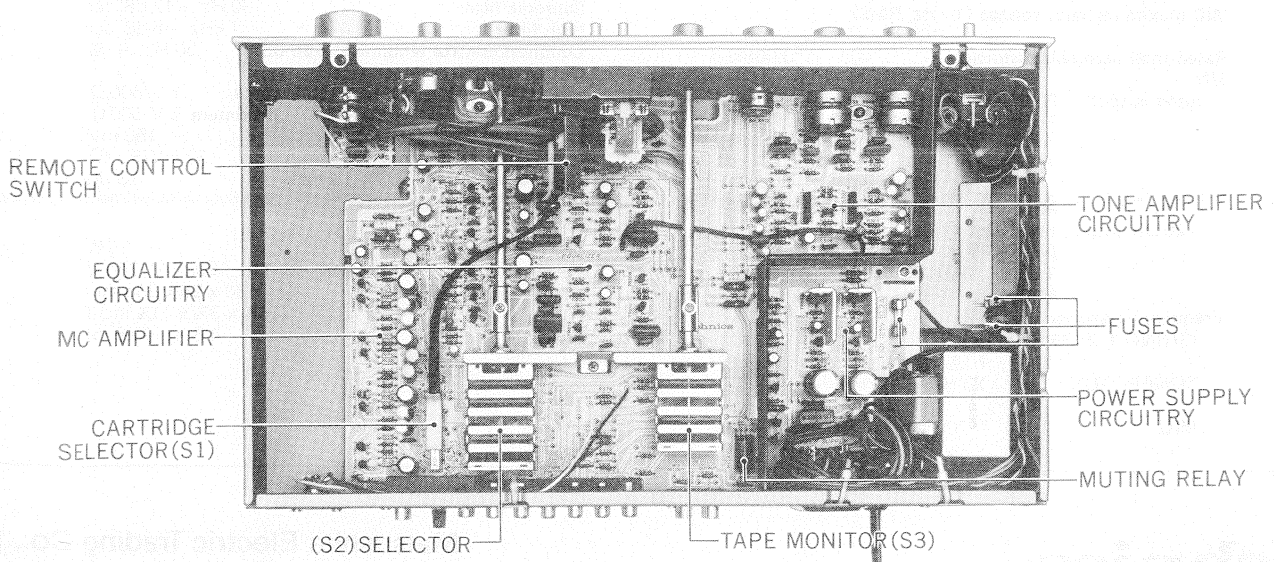

TECHNISCHE DATEN (Spezifikationen können infolge von Verbesserungen ohne Ankündigung geändert werden)

(DIN 45 500)

VERSTÄRKERTEIL

Eingangsempfindlichkeit & Impedanz	
PHONO 1 MC	70 μ V/10 Ω
PHONO 1 MM, PHONO 2	2,5 mV/47 k Ω
TUNER, AUX	150 mV/47 k Ω
TAPE 2 (PLAYBACK)	150 mV/47 k Ω
TAPE 1 (PLAYBACK), REC/PLAY (Eingang)	180 mV/47 k Ω
MIC	4 mV/10 k Ω
PHONO maximale Eingangsspannungen (1 kHz, RMS)	
PHONO 1 MC	6 mV
PHONO 1 MM, PHONO 2	200 mV
MIC Maximale Eingangsspannungen (1 kHz, RMS)	
	100 mV (T.H.D. 0,05%)
Nenn-Harmonische Verzerrungen	
	0,008%
Rauschabstand	
Nennleistung	PHONO 1 MC
	62 dB (IHF, A: 69 dB)
	PHONO 1 MM, PHONO 2
	75 dB (IHF, A: 88 dB)
	TUNER, AUX
	85 dB (IHF, A: 100 dB)
	MIC 65 dB (IHF, A: 73 dB)
-26 dB Leistung	PHONO 1 MC
	60 dB
	PHONO 1 MM, PHONO 2
	62 dB
	TUNER, AUX
	63 dB
	MIC 60 dB
Frequenzgang	
PHONO 1, 2 (30 Hz ~ 15 kHz)	RIAA standardkurve \pm 0,2 dB
TUNER, AUX	20 Hz ~ 20 kHz, +0, -0,2 dB
	5 Hz ~ 40 kHz, -1 dB
MIC	20 Hz ~ 45 kHz, +0, -3 dB

Harmonische Verzerrung (20 Hz ~ 20 kHz)

PHONO 1 MC	
1 V Ausgangs (Lautstärke bei -20 dB)	0,02%
3 V Ausgangs (Lautstärke bei 0 dB)	0,03%
PHONO 1 MM, PHONO 2	
1 V Ausgangs (Lautstärke bei -20 dB)	0,01%
3 V Ausgangs (Lautstärke bei 0 dB)	0,008%
TUNER, AUX	
1 V Ausgangs (Lautstärke bei -20 dB)	0,008%
3 V Ausgangs (Lautstärke bei 0 dB)	0,005%
Klangregler	
Bass (BÄSSE)	50 Hz +8 dB ~ -8 dB
Treble (HÖHEN)	20 kHz +8 dB ~ -8 dB
Unterschallfilter	30 Hz, -12 dB/oct
Höhenfilter	7 kHz -6 dB/oct
Gehörliche Lautstärke (Lautstärke bei -30 dB)	
	50 Hz +9 dB

Ausgangsspannungen & Impedanz

OUTPUT, MIXING REC OUT	Nennleistung
	1 V/600 Ω
	max. 5 V/600 Ω
TAPE 1, 2 (REC OUT)	150 mV
REC/PLAY (Aufnahme)	30 mV/82 k Ω
Kanaltrennung, AUX 1 kHz	53 dB

ALLGEMEINE DATEN

Leistungsaufnahme	16 W
Netzspannung (50/60 Hz)	110, 120, 220, 240 V
Abmessungen (B x H x T)	430 x 98 x 285 mm
Gewicht	4,8 kg

CARACTERISTIQUES TECHIQUES (Sujet à changement sans préavis.)

(DIN 45 500)

PARTIE AMPLIFICATEUR

Sensibilité et impédance d'entrée	
PHONO 1 MC	70 μ V/10 Ω
PHONO 1 MM, PHONO 2	2,5 mV/47 k Ω
TUNER, AUX	150 mV/47 k Ω
TAPE 2 (PLAYBACK)	150 mV/47 k Ω
TAPE 1 (PLAYBACK), REC/PLAY (entrée)	180 mV/47 k Ω
MIC	4 mV/10 k Ω
Tension maximum d'entrée PHONO (1 kHz, eff.)	
PHONO 1 MC	6 mV
PHONO 1 MM, PHONO 2	200 mV
Tension maximum d'entrée MIC (1 kHz, eff.)	
	100 mV (T.H.D. 0,05%)
Distorsion harmonique totale nominale	
	0,008%
Rapport signal/bruit	
pour la puissance nominale	
PHONO 1 MC	62 dB (IHF, A: 69 dB)
PHONO 1 MM, PHONO 2	75 dB (IHF, A: 88 dB)
TUNER, AUX	85 dB (IHF, A: 100 dB)
MIC	65 dB (IHF, A: 73 dB)
puissance de -26 dB	
PHONO 1 MC	60 dB
PHONO 1 MM, PHONO 2	62 dB
TUNER, AUX	63 dB
MIC	60 dB
Réponse de fréquence	
PHONO 1, 2 (30 Hz ~ 15 kHz)	Courbe standard RIAA \pm 0,2 dB
TUNER, AUX	20 Hz ~ 20 kHz, +0, -0,2 dB
	5 Hz ~ 40 kHz, -1 dB
MIC	20 Hz ~ 45 kHz, +0, -3 dB

Distorsion harmonique totale (20 Hz ~ 20 kHz)

PHONO 1 MC	
1 V sortie (volume à -20 dB)	0,02%
3 V sortie (volume à 0 dB)	0,03%
PHONO 1 MM, PHONO 2	
1 V sortie (volume à -20 dB)	0,01%
3 V sortie (volume à 0 dB)	0,008%
TUNER, AUX	
1 V sortie (volume à -20 dB)	0,008%
3 V sortie (volume à 0 dB)	0,005%
Réglage de la tonalité	
Bass (graves)	50 Hz +8 dB ~ -8 dB
Treble (aigus)	20 kHz +8 dB ~ -8 dB
Filterage infra-acoustique	30 Hz, -12 dB/oct
Filtre d'aigu	7 kHz -6 dB/oct
Correction physiologique (volume à -30 dB)	
	50 Hz +9 dB

Tension de sortie et Impédance

OUTPUT, MIXING REC OUT	Pour la puissance nominale
	1 V/600 Ω
	max. 5 V/600 Ω
TAPE 1, 2 (REC OUT)	150 mV
REC/PLAY (sortie)	30 mV/82 k Ω
Séparation des canaux AUX 1 kHz	53 dB

GENERALITES

Consommation	16 W
Allimentation (50/60 Hz)	110, 120, 220, 240 V
Dimensions (L x H x P)	430 x 98 x 285 mm
Poids	4,8 kg

■ TO REMOVE THE CHASSIS

1. Remove 5 setscrews (① ~ ④ in Fig. 1 and ⑤ in Fig. 2) which fasten the top board.
2. Remove the top board.
3. Remove 5 setscrews (⑥ ~ ⑩ in Fig. 1) of the front panel.
4. Remove 4 setscrews (⑪ ~ ⑭ in Fig. 2) of the rear panel.
5. Remove 2 setscrews (⑮ and ⑯ in Fig. 3) of the printed circuit board.
6. Cut off 2 leads at lead clamps (A and B in Fig. 3, Part No. SHR301).
7. Then the chassis can be removed as shown in Fig. 4.
8. When assembling the parts, make sure that wires are not caught between the chassis and the printed circuit board or the circuit board is completely fitted in the chassis, and then tighten up each setscrew.

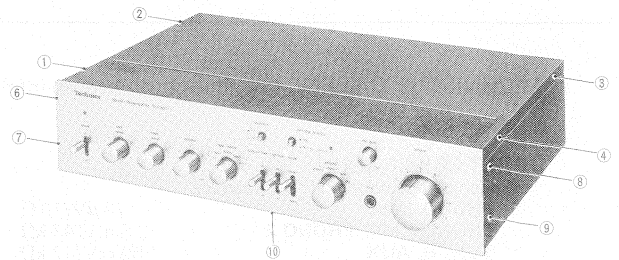

Fig. 1

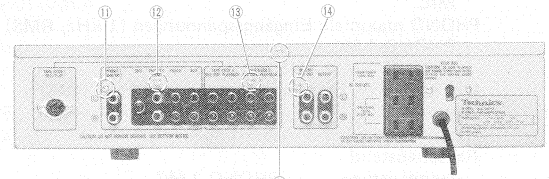

Fig. 2

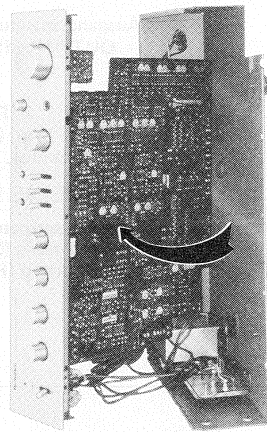

Fig. 4

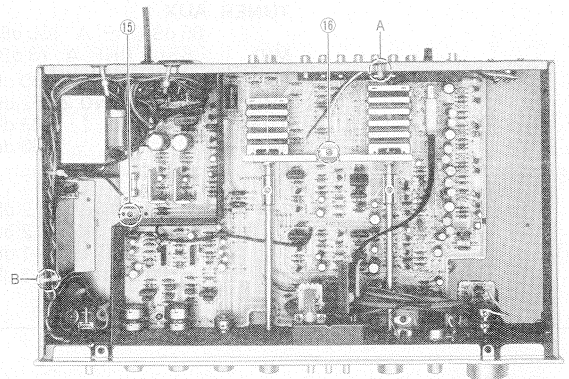

Fig. 3

■ ATTACHMENT OF FEET (INCLUDED)

This unit has an extra set of 4 feet which, if installed, lower the height by 5mm, to 93mm.

These feet are especially useful if other audio components in this series (models SE-9021 and ST-9031) are stacked one on top of another.

• Attachment

- ① Remove the feet already attached to the bottom of the unit.
- ② Attach the other set of feet (included) by using the screws (also included). Use the same holes as for the original feet.

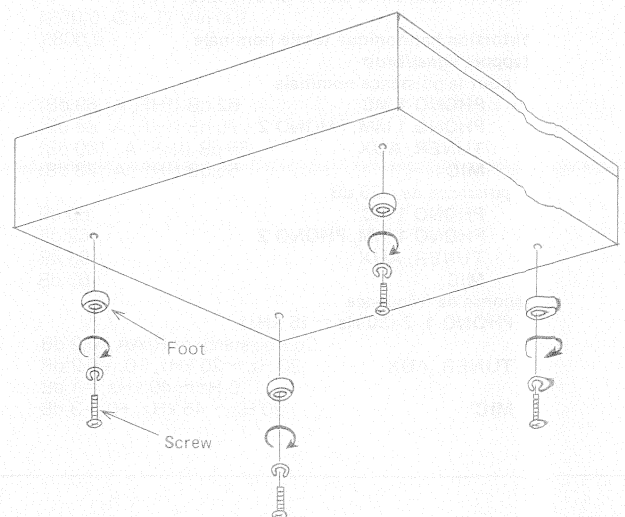
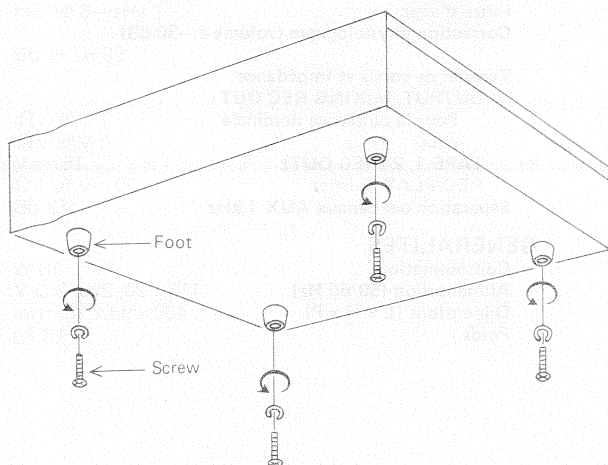

LEFT

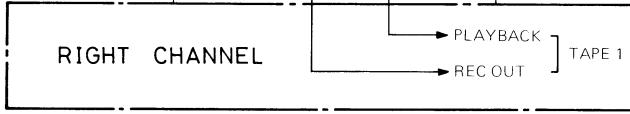
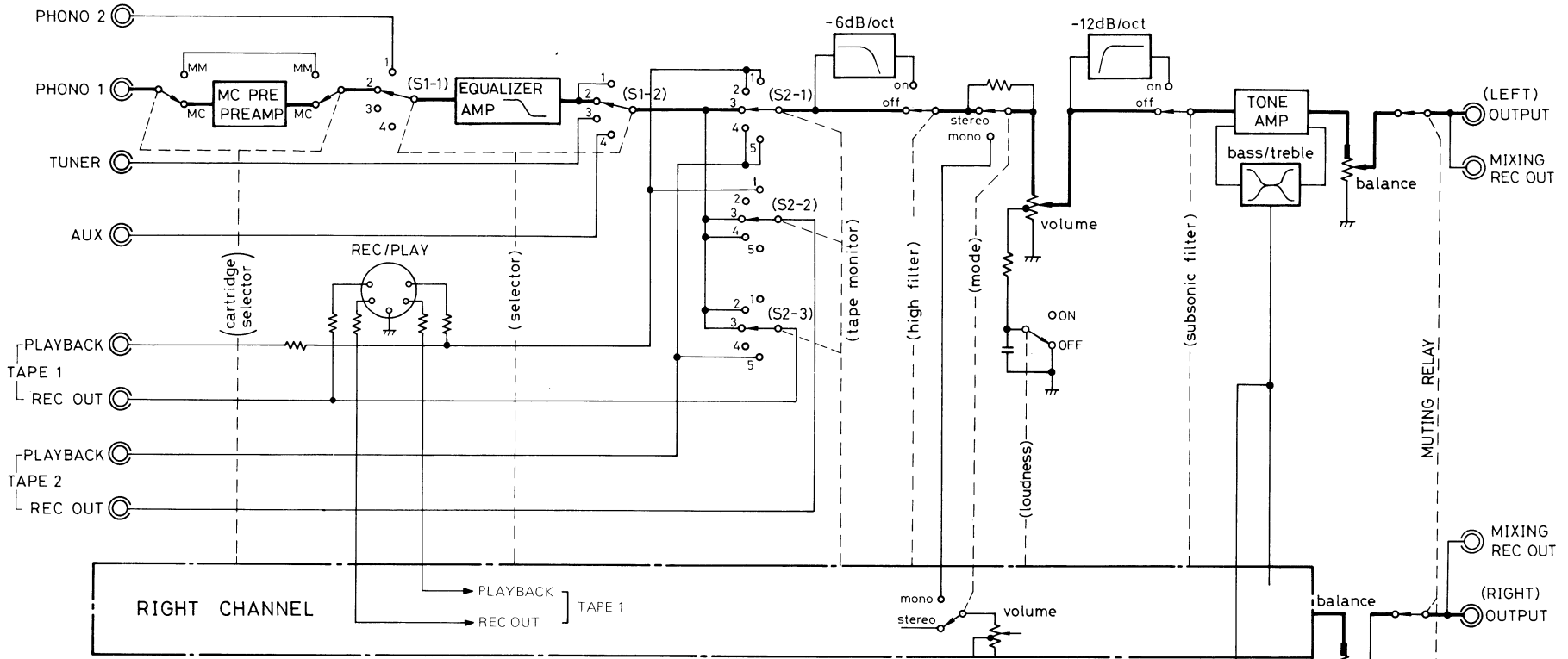

S1-1, S1-2-----selector

- 1: phono 2 (MM)
- 2: phono 1 (MM/MC)
- 3: tuner
- 4: aux

S2-1-S2-3-----tape monitor

- 1: tape 1 → 2
- 2: tape 1
- 3: source
- 4: tape 2
- 5: tape 2 → 1

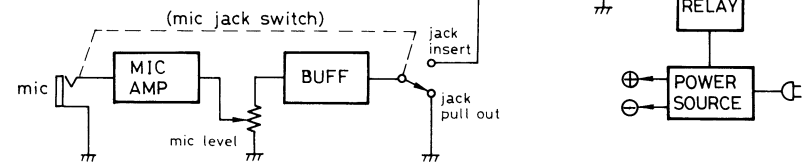

PRINTED CIRCUIT BOARD WIRING VIEW

Earth (Ground) Lines

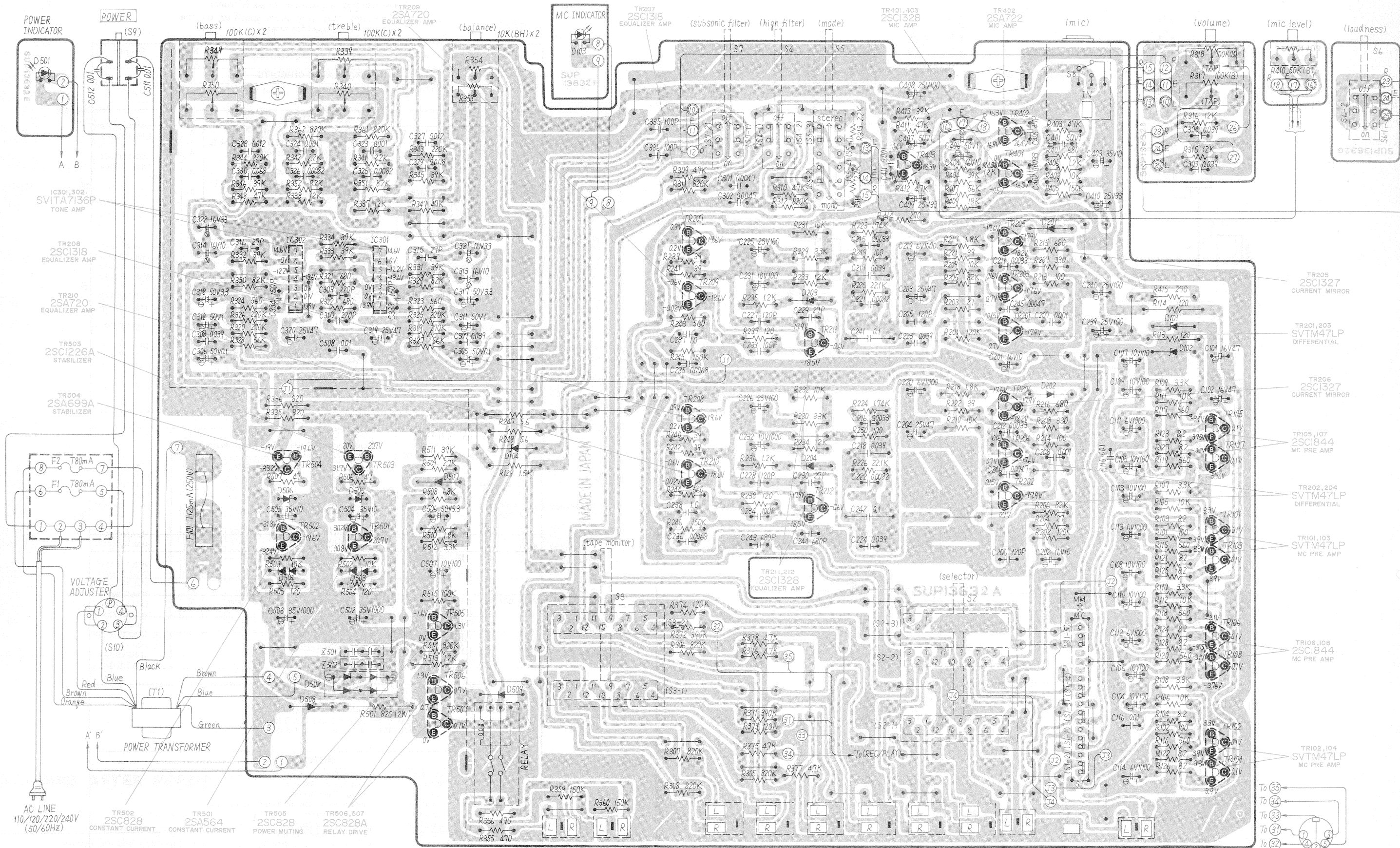

OUTPUT MIXING REC OUT TAPE 2 TAPE 1
 PLAYBACK REC OUT PLAYBACK REC OUT AUX TUNER PHONO 2 (MM) GND PHONO 1 (MM/MC) REC/PLAY

REPLACEMENT PARTS LIST Electric Parts

- NOTES 1:**
- Part numbers are indicated on most mechanical parts. Please use this part number for parts orders.
 - S** indicates that only parts specified by the manufacturer be used for safety.

Ref. No.	Part No.	Part Name & Description	Per Set	Remarks
INTEGRATED CIRCUITS				
IC301, 302	SVITA7136P	IC, Tone Amplifier	2	
TRANSISTORS				
TR101, 102, 103, 104	SVTM47LP-T	Transistor, MC Pre-Preamplifier (Use in ranks S or T)	4	
TR105, 106, 107, 108	2SC1844-F	Transistor, MC Pre-Preamplifier	4	
TR201, 202, 203, 204	SVTM47LP-T	Transistor, Differential Amplifier (Use in ranks R, S or T)	4	
TR205, 206	2SC1328-T	Transistor, Current Mirror (Use in ranks S, T or U)	2	
TR207, 208	2SC1318-R	Transistor, Equalizer Output Amplifier (Use in ranks Q or R)	2	
TR209, 210	2SA720-R	Transistor, Equalizer Output Amplifier (Use in ranks Q or R)	2	
TR211, 212, 401, 403	2SC1328-T	Transistor, Equalizer & Mic Amplifier (Use in ranks S, T or U)	4	
TR402	2SA902S-F	Transistor, Mic Amplifier (Use in ranks F or G)	1	
TR501	2SA666AI-R	Transistor, Constant Current (Use in ranks P, Q or R)	1	
TR502, 505	2SC1328-T	Transistor, Constant Current & Muting (Use in ranks P, Q or R)	2	
TR503	2SC1226A-Q	Transistor, Voltage Stabilizer (Use in ranks P, Q or R)	1	
TR504	2SA699A-R	Transistor, Voltage Stabilizer (Use in ranks P, Q or R)	1	
TR506, 507	2SC1328-T	Transistor, Relay Driver (Use in ranks P, Q or R)	2	
DIODES				
D101, 102	MA1120	Diode, 12V Zener	2	
D103, 501	LN26RP	Light Emitting Diode, MC & Power Indicator	2	
D104	SVDMZ322	Diode, 22V Zener	1	
D201, 202, 203, 204	MA150	Diode, Current Mirror & Bias Supply	7	
D502	S SVDS1RBA20	Rectifier	1	
D503, 504	SVDMA26-2	Diode, Bias Supply	2	
D505, 506	MA1200	Diode, 20V Zener	2	
TRANSFORMER				
T1	S SLT5M81	Transformer, Power Source	1	○
COMPONENT COMBINATIONS				
Z501, 502	EXRFS203ZS	Component Combination, Noise Killer	2	
FUSES				
F101	S XBAS2A01201	Fuse, T125mA (250V)	1	○
F1, 2	S XBAS2A00801	Fuse, T80mA (250V)	2	○
VARIABLE RESISTORS				
R317, 318	EFW05A031B15	Volume Control, 100kΩ (B)	1	
R339, 340	EFW9XA063C15	Treble Control, 100kΩ (C)	1	
R349, 350	EFW8XA063C15	Bass Control, 100kΩ (C)	1	
R353, 354	EWKKB085679	Balance Control, 10kΩ (BH)	1	
R410	EVHCVA081B54	Mic Level Control, 50kΩ (B)	1	
SWITCHES				
S1	ESD80511	Switch, Cartridge Selector (P.C.B. Side)	1	
S2	SSR121	Switch, Input Selector	1	
S3	SSR123	Switch, Tape Monitor	1	
S4, 5, 7	SSL109	Switch, High Filter, Mode & Subsonic Filter	1	
S6	SSH91	Switch, Loudness	1	
S9	S ESL21180	Switch, Power Source	1	
S10	S ESE372	Switch, Voltage Adjuster	1	○
RELAY				
RELAY	SSY9	Relay, Output Muting	1	

NOTES 2:

Guide letters of Resistor and Capacitor indicate:

Resistors

- ERD Carbon
- ERO Metal film
- ERQ Fuse type metallic
- ERG Metal oxide

Capacitors

- ECE Electrolytic
- ECK Ceramic
- ECQM Polyester
- ECQP Polypropylen

- ECC Ceramic
- ECQE Polyester
- ECEIN Non-Polar Electrolytic

Ref. No.	Part No.
RESISTORS	
R101, 102	ERD25TJ101
R103, 104	ERD25TJ8R2
R105, 106	ERO25CKG1002
R107, 108	ERD25TJ332
R109, 110	ERD25TJ332
R111, 112	ERO25CKG1002
R113	S ERD12FJ121
R114	S ERQ12HJ121
R115, 116	ERD25TJ561
R117, 118	ERD25TJ561
R119, 120	ERD25TJ561
R121, 122	ERD25TJ8R2
R123, 124	ERD25TJ8R2
R125, 126	ERD25TJ8R2
R127, 128	ERD25TJ8R2
R129	S ERD12FJ152
R201, 202	ERD25TJ124
R203, 204	ERD25TJ270
R205, 206	ERO25CKG8202
R207, 208	ERD25TJ331
R209, 210	ERD25TJ103
R213, 214	ERD25TJ101
R215, 216	ERD25TJ681
R217, 218	ERD14FJ182
R221, 222	ERD25TJ390
R223, 224	ERO25CKF1741
R225, 226	ERO25CKF2212
R229, 230	ERD25TJ332
R231, 232	ERD25TJ103
R233, 234	ERD25TJ123
R235, 236	ERD25TJ122
R237, 238	ERD25TJ121
R239, 240	ERD25TJ390
R241, 242	ERD25TJ390
R243, 244	ERD25TJ561
R245, 246	ERD25TJ154
R247	S ERQ12HJ5R6
R248	S ERD12FJ5R6
R249, 250	ERD25TJ101
R305, 306	ERD25TJ824
R307, 308	ERD25TJ824
R309, 310	ERD25TJ472
R311, 312	ERD25TJ824
R313, 314	ERD25TJ222
R315, 316	ERD25TJ123
R319, 320	ERD25TJ274
R321, 322	ERD25TJ681
R323, 324	ERD25TJ561
R325, 326	ERD25TJ224
R327, 328	ERD25TJ563
R329, 330	ERD25TJ823

Ref. No.	Part No.
R331, 322	ERD25TJ393
R333, 334	ERD25TJ393
R335, 336	S ERD14FJ821
R337, 338	ERD25TJ123
R341, 342	ERD25TJ222
R343, 344	ERD25TJ224
R345, 346	ERD25TJ393
R347, 348	ERD25TJ473
R351, 352	ERD25TJ822
R355, 356	ERD25TJ471
R359, 360	ERD25TJ154
R361, 362	ERD25TJ824
R371, 372	ERD25TJ394
R373, 374	ERD25TJ124
R375, 376	ERD25TJ472
R377, 378	ERD25TJ472
R401	ERD25TJ681
R402	ERD25TJ103
R403	ERD25TJ473
R404	ERD25TJ393
R405	ERD25TJ154
R406	ERD25TJ122
R407	ERD25TJ563
R408	ERD25TJ122
R409	ERD25TJ183
R411	ERD25TJ473
R412	ERD25TJ472
R413	ERD25TJ393
R414, 415	S ERD14FJ271
R501	ERG2ANJ821
R502, 503	ERD25TJ103
R504, 505	ERD25TJ121
R506, 507	ERD25TJ470
R508	ERD25TJ682
R509	ERD25TJ272
R510	ERD25TJ182
R511	ERD25TJ393
R512	ERD25TJ332
R513	S ERD12FJ122
R514	ERD25TJ824
R515	ERD25TJ104
CAPACITORS	
C101, 102	ECEA1ES470
C103, 104	ECEA10M100R
C105, 106	ECEA10M100R
C107, 108	ECEA10M100R
C109, 110	ECEA10M100R
C111, 112	ECEA0JS102
C113, 114	ECEA0JS102
C115, 116	ECKD1H103MD
C201, 202	ECEA16M10R
C203, 204	ECEA1ES470

Ref. No.	Part No.
C205, 206	ECCD1H121K
C207, 208	ECKD1H102MD
C211, 212	ECKD1H332KB
C215, 216	ECQM1H472KZ
C217, 218	ECQP1393GZ
C219, 220	ECEA0JS102
C221, 222	ECQM1H682KZ
C223, 224	ECQM1H393JZ
C225, 226	ECEA1ES101
C227, 228	ECCD1H121K
C229, 230	ECCD1H270K
C231, 232	ECEA1AS101
C233, 234	ECCD1H101K
C235, 236	ECQM1H682KZ
C237, 238	ECQE1105MZ
C239, 240	ECEA1ES101
C241, 242	ECQP1104GZ
C243, 244	ECKD2H681KB
C245, 246	ECKD1H472MD
C301, 302	ECQM1H472KZ
C303, 304	ECQM1H393KZ
C305, 306	ECEA50MR1R
C307, 308	ECQM1H393KZ
C309, 310	ECKD2H221KB
C311, 312	ECEA50MR1R
C313, 314	S ECEA16N10
C315, 316	ECCD1H270K
C317, 318	ECEA50Z3R3
C319, 320	ECEA1ES470
C321, 322	S ECEA16N33
C323, 324	ECQM1H102KZ
C325, 326	ECQM1H822KZ
C327, 328	ECQM1H123KZ
C329, 330	ECQM1H683KZ
C333, 334	ECCD1H151K
C335, 336	ECCD1H101K
C401	ECEA50MR1R
C402	ECKD1H332KB
C403, 404	ECEA1HS100
C405	ECCD1H470K
C406	S ECEA50N1
C407	ECEA2AS010
C408	ECEA1ES101
C409, 410	ECEA1VS330
C411	ECKD1H102KB
C502, 503	ECEA1VS102
C504, 505	ECEA1HS100
C506	ECEA2AS3R3
C507	ECEA1AS101
C508	ECKD1H103MD
C511, 512	S ECSC4A103M

WIRING AFTER REPAIR

- For the leads cut off when removing the chassis, secure them with lead clamps as they were.
- Make sure that the leads on the back of the printed circuit board are not too much off the board.

Schematic Diagram Model SU-9011/SU-9011K (E, EG, XE, XGE, XGH)

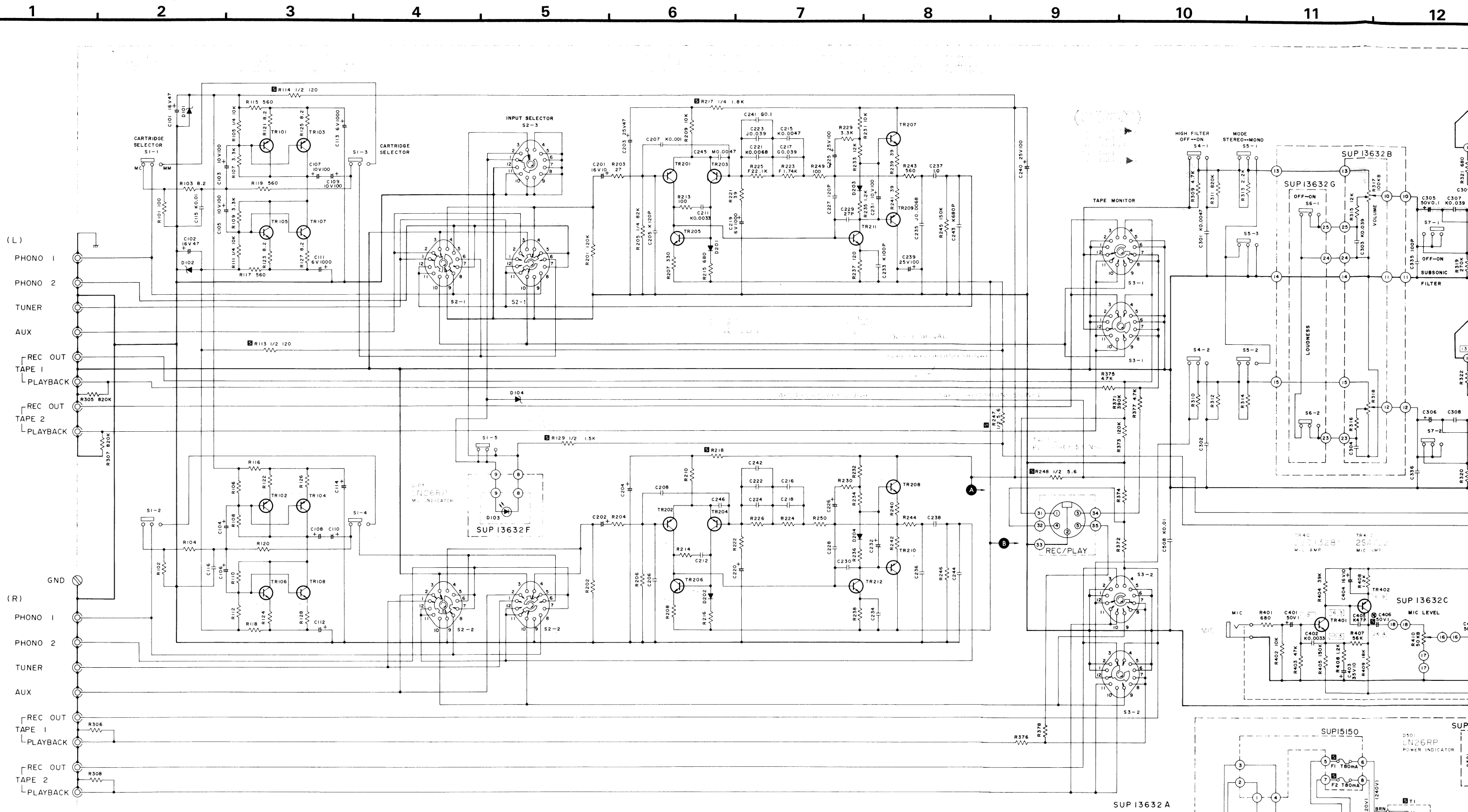

Notes:

1. S1-1 ~ S1-5 : Cartridge selector switch in "MC" position. (MM ↔ MC)
2. S2-1 ~ S2-3 : Selector switch in "phono 2" position.
(phono 2 ↔ phono 1 ↔ tuner ↔ aux)
3. S3-1, S3-2 : Tape monitor switch in "tap 1 ▶ 2" position.
(tape 1 ▶ 2 ↔ tape 1 ↔ source ↔ tape 2 ↔ tape 2 ▶ 1)
4. S4-1, S4-2 : High filter switch in "off" position.
5. S5-1 ~ S5-3 : Mode switch in "stereo" position. (stereo ↔ mono)
6. S6-1, S6-2 : Loudness switch in "off" position.
7. S7-1, S7-2 : Subsonic filter switch in "on" position.
8. S8 : Microphone switch in "off" position.
9. S9 : Power source switch in "on" position.

10. S10 : Voltage adjuster switch in "240V" position.
(240V ↔ 220V ↔ 120V ↔ 110V)
11. Indicated voltage values are the standard values for the unit measured by the DC electronic circuit tester (high impedance) with the chassis taken as standard. Therefore, there may exist some errors in the voltage values, depending on the internal impedance of the DC circuit tester.
12. [S] indicates that only parts specified by the manufacturer by used for safety.
13. Phono 2 signal lines of left channel
14. This schematic diagram may be modified at any time with the development of new technology.

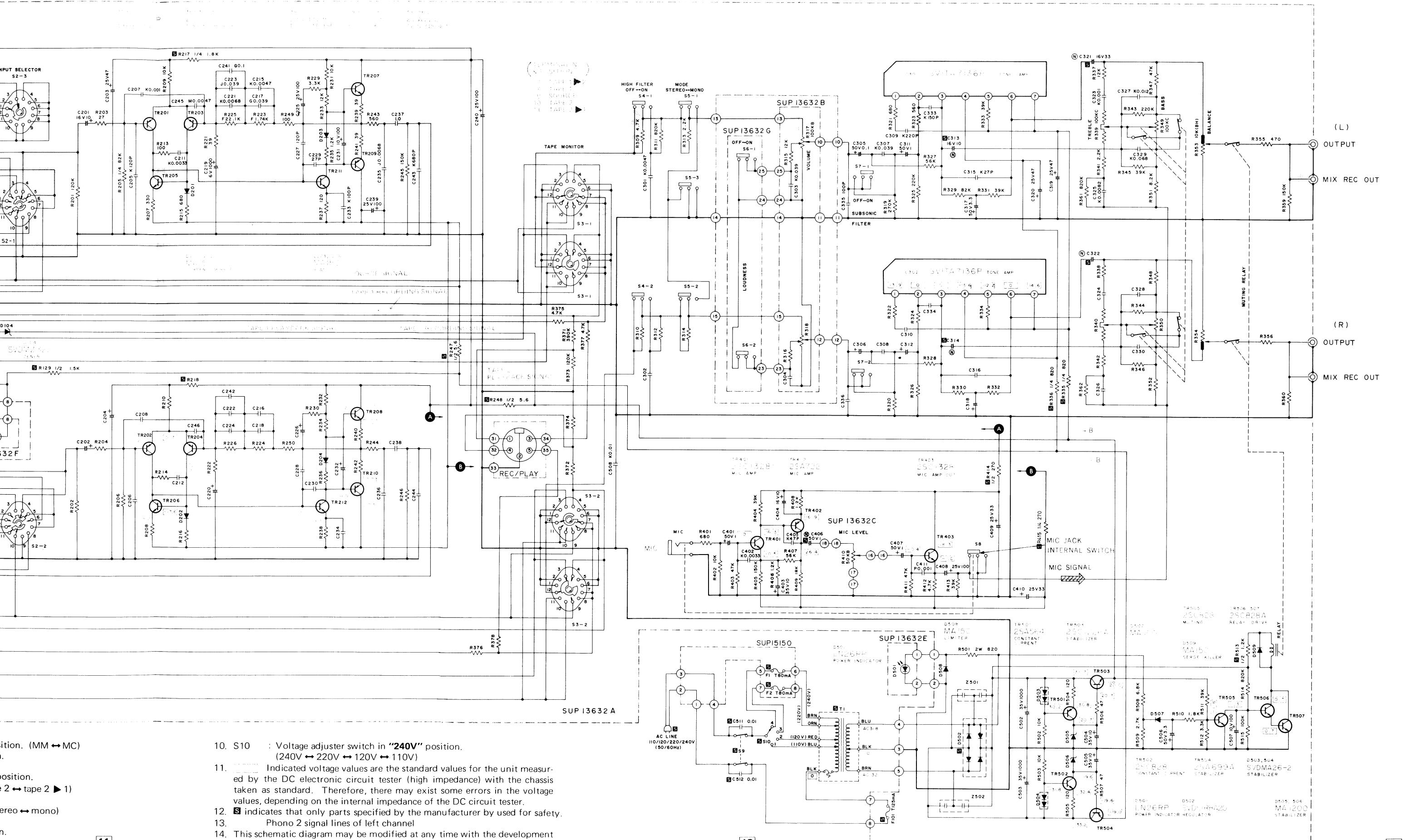

- 10. S10 : Voltage adjuster switch in "240V" position.
(240V ↔ 220V ↔ 120V ↔ 110V)
- 11. Indicated voltage values are the standard values for the unit measured by the DC electronic circuit tester (high impedance) with the chassis taken as standard. Therefore, there may exist some errors in the voltage values, depending on the internal impedance of the DC circuit tester.
- 12. S indicates that only parts specified by the manufacturer by used for safety.
- 13. Phono 2 signal lines of left channel
- 14. This schematic diagram may be modified at any time with the development of new technology.

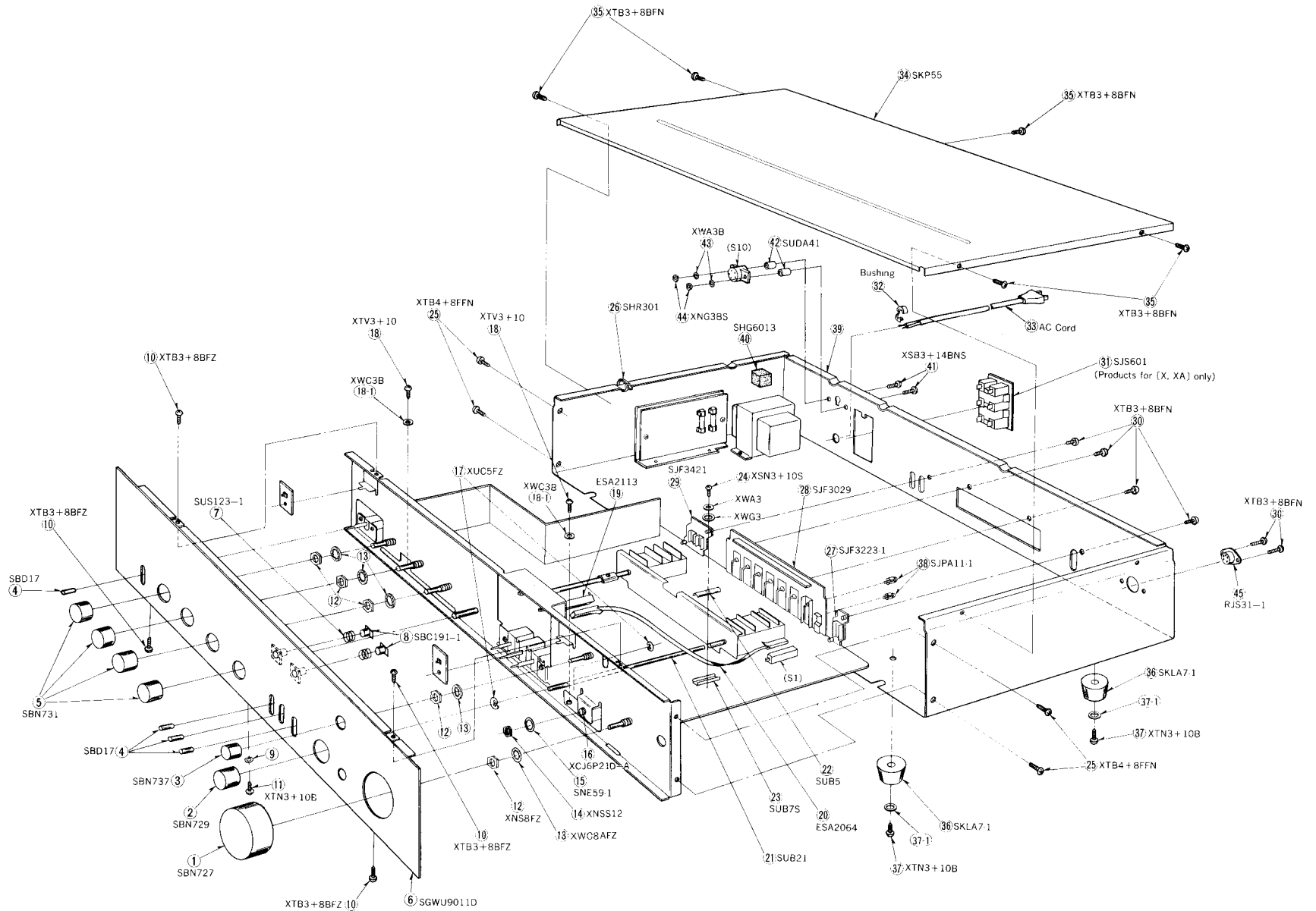

■ REPLACEMENT PARTS LIST

NOTES 1: 1. Part numbers are indicated on most mechanical parts. Please use this part number for parts orders.
 2. **S** indicates that only parts specified by the manufacturer be used for safety.

NOTES 2: (E) and (EG) are available in Scandinavia and European only. (X) and (XA) are available in Asia, Latin America, Middle East and Africa only. (XE) is available in United Kingdom only. (XGF) is available in France only. (XGH) is available in Holland only.

SU-9011K

(E), (EG), (XGH)

Note: This parts list included only the changes of the model SU-9011 parts list.

Ref. No.	Part No.	Part Name & Description	Per Set	Remarks
CABINET and CHASSIS PARTS				
1	SBN727	Knob, Volume Control	1	
2	SBN729	Knob, Selector Switch	1	
3	SBN737	Knob, Mic Level Control	1	
4	SBD17	Knob, Lever Switches	4	
5	SBN731	Knob, Bass, Treble, Balance & Tape Monitor	4	
6	SGWU9011D	Panel, Front Ass'y	1	○
7	SUS123-1	Spring, Push Switches	2	
8	SBC191-1	Button, Push Switches	2	○
9	XWG3	Washer	1	
10	XTB3+8BFZ	Screw, Front Panel M'tg	4	
11	XTN3+10B	Screw, Front Panel M'tg	1	
12	XNS8FZ	Nut, Control Volume Shaft M'tg	5	
13	XWC8AFZ	Washer, Control Volume Shaft M'tg	5	
14	XNSS12	Nut, Microphone Jack M'tg	1	
15	SNE59-1	Washer, Microphone Jack M'tg	1	
16	XCJ6P21D-A	Jack, Microphone	1	
17	XUC5FZ	Circlip	4	
18	XTV3+10	Screw, P.C.B. M'tg	2	
18-1	XWC3B	Washer	2	
19	ESA2113	Switch, Remote Control	1	
20	ESA2064	Wire, Remote Control Switch	1	
21	SUB21	Coupling Rod, Selector & Tape Switch	2	
22	SUB5	Bracket, Coupler	2	
23	SUB7S	Bracket, Coupler	2	
24	XSN3+10S	Screw, Coupler Bracket M'tg	2	
25	XTB4+8FFN	Screw, Chassis M'tg	4	
26	SHR301	Clamp, Lead Wire	1	
27	SJF3223-1	Terminal, PHONO 1 Input	1	
28	SJF3029	Terminal, Phono, Tuner, Tape Deck	1	
29	SJF3421	Terminal, Output	1	
30	XTB3+8BFN	Screw, Terminals & DIN Socket M'tg	6	
31 [X, XA] only	SJS601	Socket, AC Outlet	1	
32	SHR127	Bushing, AC Cord	1	
32 [XE] only	SHR129	Bushing, AC Cord	1	
33	RJA23ZC	AC Cord, with Plug	1	
33 [X, XA] only	SJA97	AC Cord, with Plug	1	
33 [XE] only	RJA45ZC	AC Cord	1	
34	SKP55	Top Board	1	
35	XTB3+8BFN	Screw, Top Board M'tg	5	
36	SKLA7-1	Foot, Set	4	
37	XTN3+10B	Screw, Feet M'tg	4	
37-1	XWG3	Washer	4	
38	XWG3	Washer	4	
39 [E] only	SJPA11-1	Short Pin, PHONO 2 Input Terminal	2	
39 [X, XA] only	SGP1590A	Rear Panel (w/Chassis)	1	○
	SGP1590-1A	Rear Panel (w/Chassis)	1	○
	SGPU9011D	Rear Panel, SGP1590A with Name Plate SGT17230 (EG, XE, XGF, XGH)	1	○
40	SHG6013	Rubber Cushion	1	○
41	XSB3+14BNS	Screw, Voltage Adjuster M'tg	2	
42	SUDA41	Sleeve, Voltage Adjuster	2	*
43	XWA3B	Washer	2	
44	XNG3BS	Nut, Voltage Adjuster M'tg	2	
45	RJS31-1	Socket, DIN (REC/PLAY)	1	

Ref. No.	Change of Part No.		Part Name & Description	Per Set (Pcs.)	Remarks
	SU-9011	SU-9011K			
CABINET and CHASSIS PARTS					
1	SBN727	SBN727-1	Knob, Volume Control	1	○
2	SBN729	SBN729-1	Knob, Selector Switch	1	○
3	SBN737	SBN737-1	Knob, Mic Level Control	1	○
4	SBD17	SBD17-1	Knob, Lever Switches	4	○
5	SBN731	SBN731-1	Knob, Bass, Treble, Balance & Tape Monitor	4	○
6	SGWU9011D	SGWU9011KD	Panel, Front Ass'y	1	○
8	SBC191-1	SBC191-2	Button, Push Switches	2	
25	XTB4+8FFN	XTB4+8BFZ	Screw, Chassis M'tg	4	
30	XTB3+8BFN	XTB3+8BFZ	Screw, Terminals & DIN Socket M'tg	6	
32	SHR127	SHR127	Bushing, AC Cord	1	
	RJA23ZC	RJA23ZC	AC Cord	1	
33	SJA97 [X, XA]	RJA45ZC [XE]	AC Cord	1	
34	SKP55	SKP55-2	Top Board	1	
35	XTB3+8BFN	XTB3+8BFZ	Screw, Top Board M'tg	5	
	SGP1590A [E]	SGP1590B [E] only	Rear Panel (w/Chassis)	1	○
39	SGP1590-1A [X, XA]	SGPU9011KD [EG, XGH]	Rear Panel, SGP1590B with Name Plate (SGT17250)	1	○
	SGPU9011D	SGPU9011KD	Rear Panel, SGP1590A with Name Plate (SGT17230)	1	○
41	XSB3+14BNS	XSB3+14FZS	Screw, Voltage Adjuster M'tg	2	
ACCESSORIES					
A5	SJP5213-1 [X, XA]	Deletion		0	
A6	SJP5215 [X, XA]	Deletion		0	
PACKING PARTS					
P5	SPS1823 [X, XA]	Deletion		0	
P6	SPG1675 [X, XA]	SPG1677	Carton Box	1	○
	SPG1673 [XGF]				
P7	SQF1981	SQF1981	Instructions Book, Printed Matter	1	
	SQF1983 [X, XA, XE]				

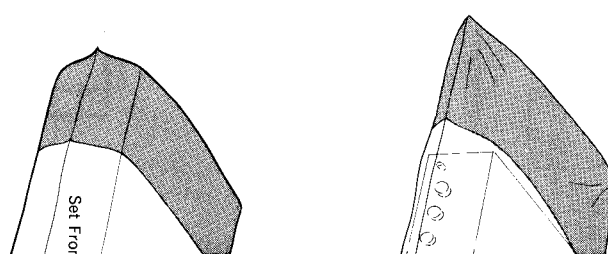

■ PACKINGS

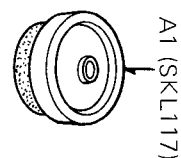

■ ACCESSORIES

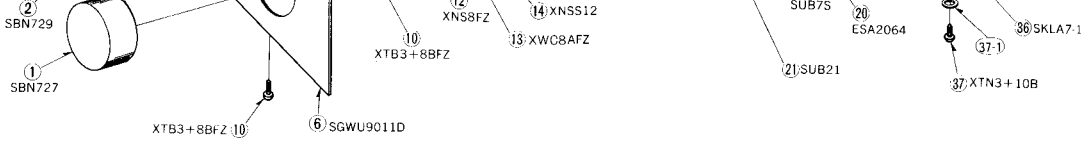

REPLACEMENT PARTS LIST

- NOTES 1:**
- Part numbers are indicated on most mechanical parts. Please use this part number for parts orders.
 - S** indicates that only parts specified by the manufacturer be used for safety.

- NOTES 2:**
- (E) and (EG) are available in Scandinavia and European only.
 (X) and (XA) are available in Asia, Latin America, Middle East and Africa only.
 (XE) is available in United Kingdom only.
 (XGF) is available in France only.
 (XGH) is available in Holland only.

Ref. No.	Part No.	Part Name & Description	Per Set	Remarks
CABINET and CHASSIS PARTS				
1	SBN727	Knob, Volume Control	1	
2	SBN729	Knob, Selector Switch	1	
3	SBN737	Knob, Mic Level Control	1	
4	SBD17	Knob, Lever Switches	4	
5	SBN731	Knob, Bass, Treble, Balance & Tape Monitor	4	
6	SGWU9011D	Panel, Front Ass'y	1	○
7	SUS123-1	Spring, Push Switches	2	
8	SBC191-1	Button, Push Switches	2	○
9	XWG3	Washer	1	
10	XTB3+8BFZ	Screw, Front Panel M'tg	4	
11	XTN3+10B	Screw, Front Panel M'tg	1	
12	XNS8FZ	Nut, Control Volume Shaft M'tg	5	
13	XWC8AFZ	Washer, Control Volume Shaft M'tg	5	
14	XNSS12	Nut, Microphone Jack M'tg	1	
15	SNE59-1	Washer, Microphone Jack M'tg	1	
16	XCJ6P21D-A	Jack, Microphone	1	
17	XUC5FZ	Circlip	4	
18	XTV3+10	Screw, P.C.B. M'tg	2	
18-1	XWC3B	Washer	2	
19	ESA2113	Switch, Remote Control	1	
20	ESA2064	Wire, Remote Control Switch	1	
21	SUB21	Coupling Rod, Selector & Tape Switch	2	
22	SUB5	Bracket, Coupler	2	
23	SUB75	Bracket, Coupler	2	
24	XSN3+10S	Screw, Coupler Bracket M'tg	2	
25	XTB4+8FFN	Screw, Chassis M'tg	4	
26	SHR301	Clamp, Lead Wire	1	
27	SJF3223-1	Terminal, PHONO 1 Input	1	
28	SJF3029	Terminal, Phono, Tuner, Tape Deck	1	
29	SJF3421	Terminal, Output	1	
30	XTB3+8BFN	Screw, Terminals & DIN Socket M'tg	6	
31 [X, XA] only	SJS601	Socket, AC Outlet	1	
32	SHR127	Bushing, AC Cord	1	
32 [XE] only	SHR129	Bushing, AC Cord	1	
33	RJA23ZC	AC Cord, with Plug	1	S
33 [X, XA] only	SJA97	AC Cord, with Plug	1	S
33 [XE] only	RJA45ZC	AC Cord	1	S
34	SKP55	Top Board	1	
35	XTB3+8BFN	Screw, Top Board M'tg	5	
36	SKLA7-1	Foot, Set	4	
37	XTN3+10B	Screw, Feet M'tg	4	
37-1	XWG3	Washer	4	
38	SJPA11-1	Short Pin, PHONO 2 Input Terminal	2	
39 [E] only	SGP1590A	Rear Panel (w/Chassis)	1	○ ○ ○ ○
39 [X, XA] only	SGP1590-1A	Rear Panel (w/Chassis)	1	
39	SGPU9011D	Rear Panel, SGP1590A with Name Plate SGT17250 (EG, XE, XGF, XGH)	1	○ ○ ○ ○
40	SHG6013	Rubber Cushion	1	○
41	XSB3+14BNS	Screw, Voltage Adjuster M'tg	2	
42	SUDA41	Sleeve, Voltage Adjuster	2	*
43	XWA3B	Washer	2	
44	XNG3BS	Nut, Voltage Adjuster M'tg	2	
45	RJS31-1	Socket, DIN (REC/PLAY)	1	

SU-9011K

(E), (EG), (XGH)

Note: This parts list included only the changes of the model SU-9011 parts list.

Ref. No.	Change of Part No.		Part Name & Description	Per Set (Pcs.)	Remarks
	SU-9011	SU-9011K			
CABINET and CHASSIS PARTS					
1	SBN727	SBN727-1	Knob, Volume Control	1	○
2	SBN729	SBN729-1	Knob, Selector Switch	1	○
3	SBN737	SBN737-1	Knob, Mic Level Control	1	○
4	SBD17	SBD17-1	Knob, Lever Switches	4	○
5	SBN731	SBN731-1	Knob, Bass, Treble, Balance & Tape Monitor	4	○
6	SGWU9011D	SGWU9011KD	Panel, Front Ass'y	1	○
8	SBC191-1	SBC191-2	Button, Push Switches	2	
25	XTB4+8FFN	XTB4+8BFZ	Screw, Chassis M'tg	4	
30	XTB3+8BFN	XTB3+8BFZ	Screw, Terminals & DIN Socket M'tg	6	
32	SHR127	SHR127	Bushing, AC Cord	1	
	RJA23ZC	RJA23ZC	AC Cord	1	
33	SJA97 [X, XA]	RJA23ZC	AC Cord	1	
	RJA45ZC [XE]				
34	SKP55	SKP55-2	Top Board	1	
35	XTB3+8BFN	XTB3+8BFZ	Screw, Top Board M'tg	5	
	SGP1590A [E]	SGP1590B [E] only	Rear Panel (w/Chassis)	1	○
39	SGP1590-1A [X, XA]	SGPU9011KD [EG, XGH]	Rear Panel, SGP1590B with Name Plate (SGT17250)	1	○
41	XSB3+14BNS	XSB3+14FZS	Screw, Voltage Adjuster M'tg	2	
ACCESSORIES					
A5	SJP5213-1 [X, XA]	Deletion	-----	0	
A6	SJP5215 [X, XA]	Deletion	-----	0	
PACKING PARTS					
P5	SPS1823 [X, XA]	Deletion	-----	0	
P6	SPG1675 [X, XA]	SPG1677	Carton Box	1	○
P7	SQF1981	SQF1981	Instructions Book, Printed Matter	1	
	SQF1983 [X, XA, XE]				

SU-9011/K SU-9011/K

15

16

ACCESSORIES

PACKINGS

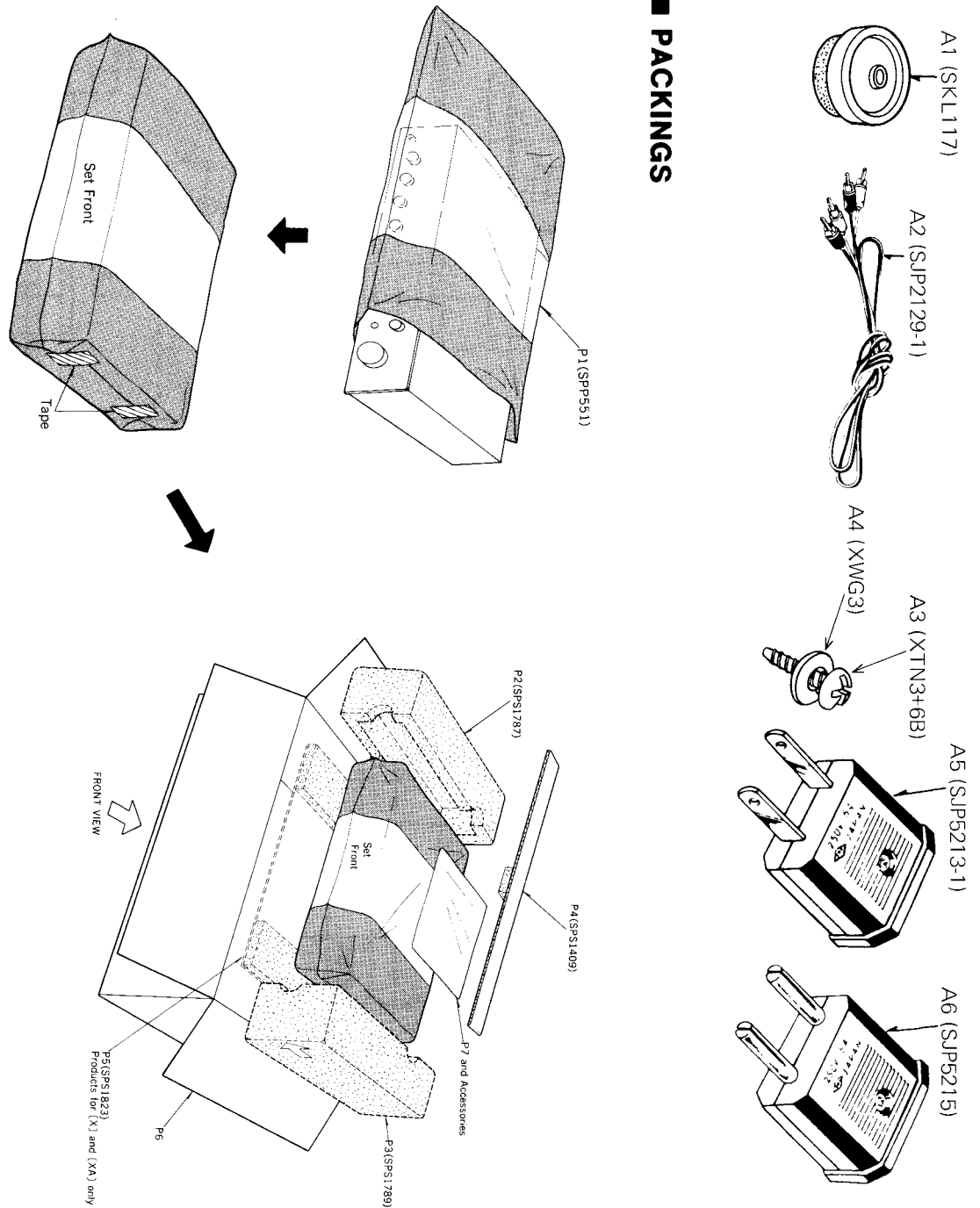

Ref. No.	Part No.	Part Name & Description	Per Set	Remarks
ACCESSORIES				
A1	SKL117	Foot Connector	4	
A2	SJP2129-1	Cord, Connector	1	
A3	XTN3+6B	Screw, Feet M'tg	4	
A4	XWG3	Washer	4	
A5 [X, XA] only	SJP5213-1	Plug Adapter, AC Power	1	
A6 [X, XA] only	SJP5215	Plug Adapter, AC Power	1	
PACKING PARTS				
P1	SPS51	Polyethylene Bag	1	
P2	SPS1787	Pad, Left Side	1	○
P3	SPS1789	Pad, Right Side	1	○
P4	SPS1409	Pad, Upper Side	1	○
P5	SPS1823	Pad, Lower Side	1	○
P6	SPG1675	Carton Box	1	○
P6 [X, XA] only	SPG1673	Carton Box	1	○
P6 [XGF] only	SQF1981	Instructions Book, Printed Matter	1	○
P7 [X, XA, XE] only	SQF1983	Instructions Book, Printed Matter	1	○