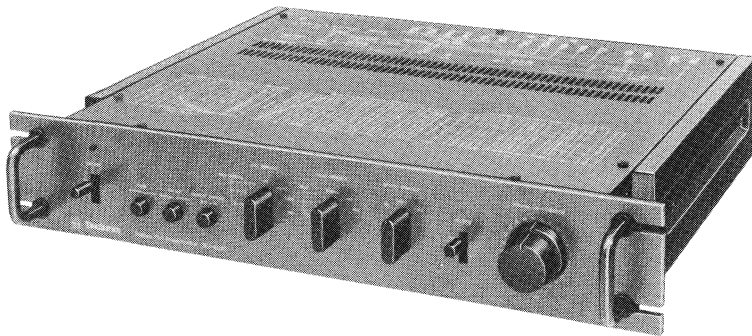

Service Manual

Stereo Flat Preamplifier

SU-9070

(X), (XM), (XG), (XGH),
(XGF), (XSD), (XSW), (XE)

The model SU-9070 (X) is available in Asia, Latin America, Middle East and Africa only.

The model SU-9070 (XM) is Panama and Mexico only.

The model SU-9070 (XG) is available in European only.

The model SU-9070 (XGH) is available in Holland only.

The model SU-9070 (XGF) is available in France only.

The model SU-9070 (XSD) is available in Scandinavia only.

The model SU-9070 (XSW) is available in Switzerland only.

The model SU-9070 (XE) is available in England only.

TECHNICAL SPECIFICATIONS

(Specifications are subject to change without notice for further improvement.)

[DIN 45 500]

Input sensitivity & impedance

PHONO MC	60 μ V/47 Ω
MM1, MM2	2.5mV/47k Ω
TUNER, AUX	150mV/47k Ω
TAPE DECK 1, 2, 3 (PLAYBACK)	150mV/47k Ω

Phono maximum input voltage (1kHz, RMS)

MC	9mV
MM1, MM2	380mV

Rated total harmonic distortion

S/N rated output PHONO MC	62 dB (IHF, A: 72 dB)
MM1, 2	70 dB (IHF, A: 88 dB)
TUNER, AUX	90 dB (IHF, A: 106 dB)

-26 dB output PHONO MC	63 dB
MM1, 2	68 dB
TUNER, AUX	73 dB

Total harmonic distortion (20 Hz ~ 20 kHz)

PHONO MC 10V output (volume at 0 dB)	0.02%
1V output (volume at -30 dB)	0.01%

PHONO MM1, 2 10V output (volume at 0 dB)	0.003%
1V output (volume at -30 dB)	0.003%
TUNER, AUX 10V output (volume at 0 dB)	0.003%
1V output (volume at -30 dB)	0.003%

Frequency response

PHONO (20 Hz ~ 20 kHz)	RIAA standard curve \pm 0.2 dB
TUNER, AUX	20 Hz ~ 20 kHz, +0dB -0.05 dB
	0 Hz ~ 100 kHz, +0 dB -1 dB

Equalizer subsonic filter

20 Hz, -12 dB/oct.

Muting

-20 dB

Output voltage & impedance

OUTPUT rated	1V/600 Ω
maximum	20V/600 Ω
REC OUT (TAPE DECK 1, 2, 3)	150mV
Channel separation	75 dB
Power consumption	30 W
Power supply (50/60Hz)	220 V/240 V or 120 V
Dimensions (W x H x D)	450 x 92 x 369 mm
	(17-23/32" x 3-5/8" x 14-17/32")

Weight

7.0 kg (15.4 lb.)

TECHNISCHE DATEN (Spezifikationen können infolge von Verbesserungen ohne Ankündigung geändert werden)

[DIN 45 500]

Eingangsempfindlichkeit & Impedanz

PHONO MC	60 μ V/47 Ω
MM1, MM2	2,5 mV/47k Ω
TUNER, AUX	150 mV/47k Ω
TAPE DECK 1, 2, 3(PLAYBACK)	150 mV/47k Ω

PHONO Maximale Eingangsspannung (1 kHz RMS)

MC	9 mV
MM1, MM2	380 mV

Nenn Harmonische Verzerrungen

0,003%

Fremdspannungsabstand

Nenn Ausgangsspannung	
PHONO MC	62 dB (IHF, A: 72 dB)
MM1, 2	70 dB (IHF, A: 88 dB)
TUNER, AUX	90 dB (IHF, A: 106 dB)

-26 dB Ausgangsspannung

PHONO MC	63 dB
MM1, 2	68 dB
TUNER, AUX	73 dB

Harmonische Verzerrungen (20 Hz ~ 20 kHz)

PHONO MC 10V Ausgangsspannung (Lautstärke bei 0 dB)	0,02%
1V Ausgangsspannung (Lautstärke bei -30 dB)	0,01%

PHONO MM1, 2

10V Ausgangsspannung (Lautstärke bei 0 dB)	0,003%
1V Ausgangsspannung (Lautstärke bei -30 dB)	0,003%

TUNER, AUX

10V Ausgangsspannung (Lautstärke bei 0 dB)	0,003%
1V Ausgangsspannung (Lautstärke bei -30 dB)	0,003%

Frequenzgang

PHONO (20 Hz ~ 20 kHz)	RIAA Standardkurve \pm 0,2 dB
TUNER, AUX	20 Hz ~ 20 kHz, +0 dB -0,05 dB
	0 Hz ~ 100 kHz, +0 dB -1 dB

Entzerrungs Unterschallfilter

20 Hz, -12 dB/oct.

Stummabstimmung

-20 dB

Ausgangsspannungn & Impedanz

OUTPUT Nominal	1V/600 Ω
Maximal	20V/600 Ω
REC OUT (TAPE DECK 1, 2, 3)	150 mV
Kanaltrennung	75 dB
Leistungsaufnahme	30 W
Netzspannung umschaltbar (50/60Hz)	220V/240V oder 120 V
Abmessungen (B x H x T)	450 x 92 x 369 mm
Gewicht	7,0 kg

CARACTERISTIQUES TECHNIQUES (Sujet à changement sans préavis.)

[DIN 45 500]

Sensibilité & impédance d'entrée		PHONO MM1, 2	60 μ V/47 Ω	PHONO MM1, 2	10V de sortie (volume à 0 dB)	0,003%
		MC	2,5 mV/47 k Ω	TUNER, AUX	1V de sortie (volume à -30 dB)	0,003%
		MM1, MM2	150 mV/47 k Ω	TUNER, AUX	10V de sortie (volume à 0 dB)	0,003%
		TUNER, AUX	150 mV/47 k Ω	TUNER, AUX	1V de sortie (volume à -30 dB)	0,003%
Voltage d'entrée maximum PHONO (1 kHz RMS)		MC	9 mV	Réponse de fréquence		
		MM1, MM2	380 mV	PHONO (20 Hz ~ 20 kHz) Courbe standard RIAA $\pm 0,2$ dB		
Pour distortion harmonique totale			0.003%	TUNER, AUX 20 Hz ~ 20 kHz, +0 dB -0.05 dB		
Signal/bruit				0 Hz ~ 100 kHz, +0 dB -1 dB		
Pour la puissance nominale				Filtrage intra acoustique compensateur 20 Hz, -12 dB/oct.		
PHONO MC			62 dB (IHF, A: 70 dB)	Silencieux -20 dB		
MM1, 2			70 dB (IHF, A: 88 dB)	Tension de sortie et impédance		
TUNER, AUX			90 dB (IHF, A: 106 dB)	OUTPUT à tension nominale 1 V/600 Ω		
Pour une sortie de -26 dB		PHONO MC	63 dB	à tension maximum 20 V/600 Ω		
		MM1, 2	68 dB	REC OUT (TAPE DECK 1, 2, 3) 150mV		
		TUNER, AUX	73 dB	Ecart canaux 75 dB		
Distorsion harmonique totale (20 Hz ~ 20 kHz)				Consommation 30 W		
		PHONO MC	10V de sortie (volume à 0 dB)	Alimentation (50/60 Hz) 220 V/240 V ou 120 V		
		1V de sortie (volume à -30 dB)	0,02%	Dimensions (L x H x Pr) 450 x 92 x 369 mm		
			0,01%	Poids 7,0 kg		

LOCATION OF CONTROLS

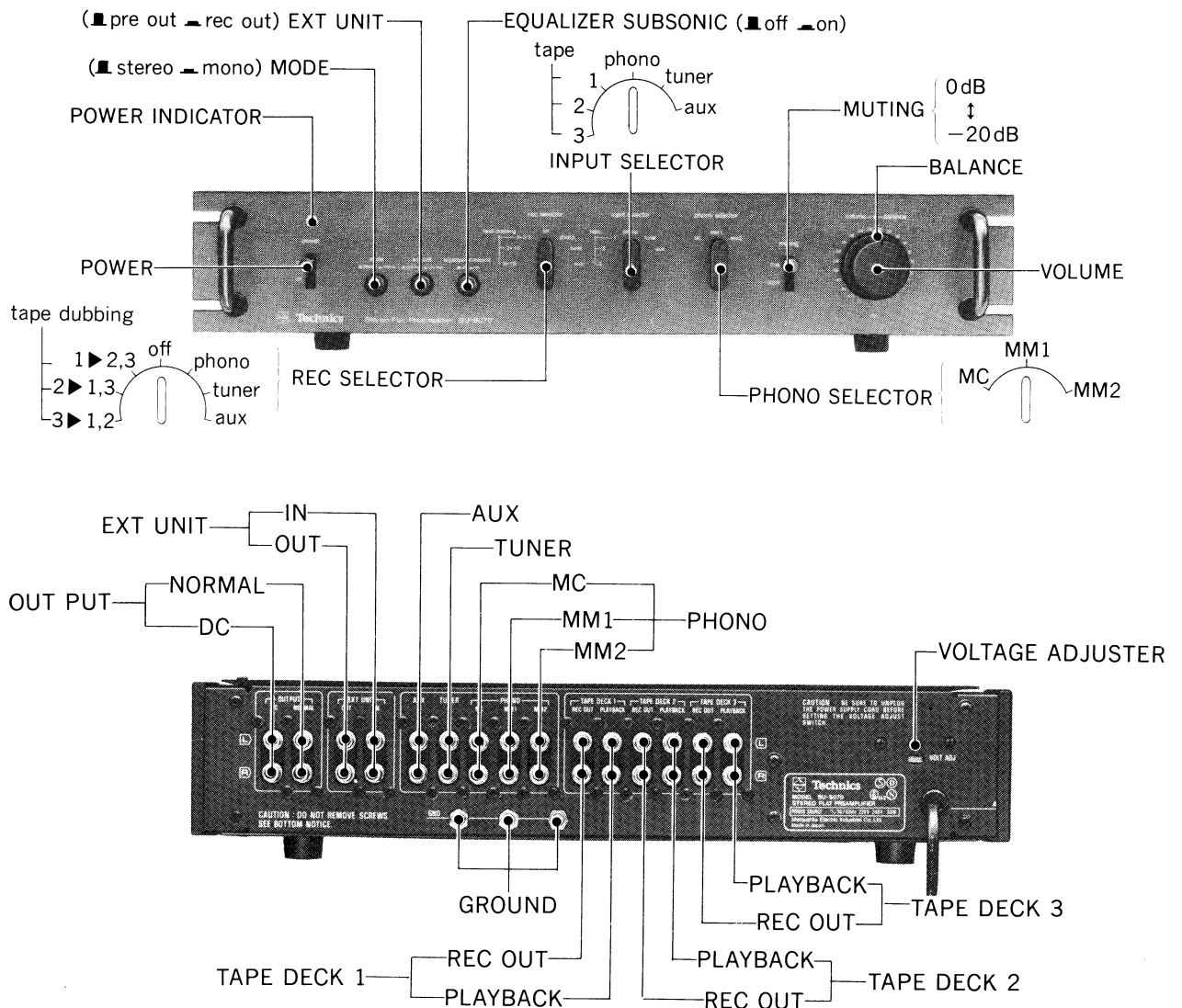

* For further remark, the products for [XM] are not provided with voltage adjuster

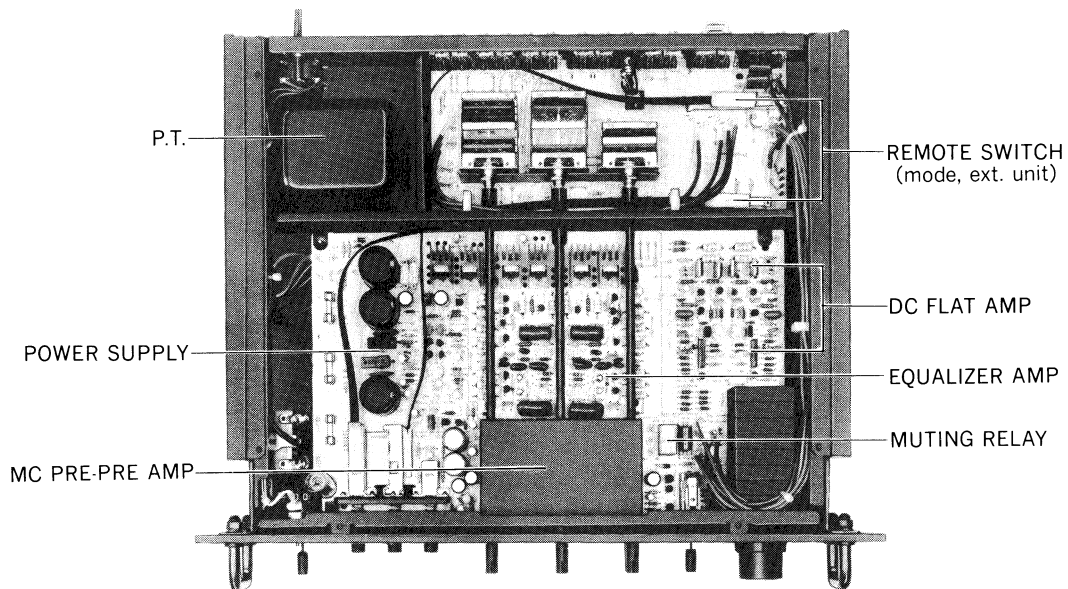

■ ALIGNMENT INSTRUCTIONS

• Conditions of set

1. Volume control Maximum (0 dB)
2. Input selector switch TUNER
3. EXT UNIT switch PRE OUT

1. ADJUSTMENT OF CONSTANT-VOLTAGE POWER SUPPLY

- ① . Connect the (–) terminal of a D.C. voltmeter* to TP401 (ground), and the (+) terminal to TP402 , and adjust VR401 for $-\frac{43V}{42V}$.

2. ADJUSTMENT OF DC UNBALANCED VOLTAGE

- ① For the left channel, connect the (–) terminal of the D.C. voltmeter to TP303 (ground), and the (+) terminal to TP301.
- ② In the 1 mV range of the D.C. voltmeter, adjust VR301 for 0 mV.
- ③ For the right channel, connect the (–) terminal of the D.C. voltmeter to TP303 (ground), and the (+) terminal to TP302.
- ④ In the 1 mV range of the D.C. voltmeter, adjust VR302 for 0 mV.

Notes: * Use a D.C. voltmeter which can measure up to several mV.

* When D.C. unbalance adjustment can't adjust for 0mV by adjustment volumes, cut off the lead wire for J301 in the case of left channel. (The lead wire for J302 in the case of right channel.)

■ ABGLEICHANWEISUNGEN

• Diagramm für die abzustimmenden Teile (Abb. 1)

• Bedingung des Gerätes

1. Lautstärkeregler Maximum (0 dB)
2. Eingangswahlschalter TUNER
3. Außeneinheit-Wahlschalter (EXT UNIT) PRE OUT

1. JUSTIERUNG DER STROMVERSORGUNG MIT GLEICHBLEIBENDER SPANNUNG

- ① Den (–)-Anschluß eines Gleichstrom-Voltmeters* an TP401 (ground) und den (+)-Anschluß an TP402 anschließen, und VR401 auf –43V abgleichen.

2. JUSTIERUNG DER UNAUSGEGLICHENEN GLEICHSTROMSPANNUNG

- ① Für den linken Kanal, den (–)-Anschluß des Gleichstrom-Voltmeters an TP303 (ground) und den (+)-Anschluß an TP301 anschließen.
- ② VR301 im 1 mV Bereich des Gleichstrom-Voltmeters auf 0 mV abgleichen.
- ③ Für den rechten Kanal, den (–)-Anschluß des Gleichstrom-Voltmeters an TP303 (ground) und den (+)-Anschluß an TP302 anschließen.
- ④ VR303 im 1 mV Bereich des Gleichstrom-Voltmeters auf 0 mV abgleichen.

* Verwenden Sie einen Gleichstrom-Voltmeter, der bis auf mehrere mV zu messen vermag.

■ INSTRUCTIONS D'ALIGNEMENT ET DE REGLAGE

- Diagramme des sections devant être réglées (Fig. 1)
- Conditions de l'ensemble

1. Réglage du volume Maximum (0 dB).
2. Commutateur sélecteur d'entrée . . . TUNER. PRE OUT (Sortie du préamplificateur)
3. Commutateur pour l'appareillage externe (EXT UNIT) . . .

1. MISE AU POINT DE L'ALIMENTATION DE TENSION CONSTANTE

- ① Brancher la borne (–) du voltmètre* C.C. à TP401 (terre) et la borne (+) à TP402 et régler VR401 pour ~~43V~~ 42V.

2. MISE AU POINT POUR UNE TENSION DISSYMMÉTRIQUE C.C.

- ① Pour le canal de gauche, brancher la borne (–) du voltmètre C.C. à TP303 (terre) et la borne (+) à TP301.
 - ② Dans la plage de 1 mV du voltmètre C.C., régler VR301 pour 0 mV.
 - ③ Pour le canal de droite, brancher la borne (–) du voltmètre C.C. à TP303 (terre) et la borne (+) à TP302.
 - ④ Dans la plage de 1 mV du voltmètre C.C., régler VR302 pour 0 mV.
- * Utiliser un voltmètre C.C. qui puisse mesurer jusqu'à plusieurs mV.

■ ALIGNMENT POINTS

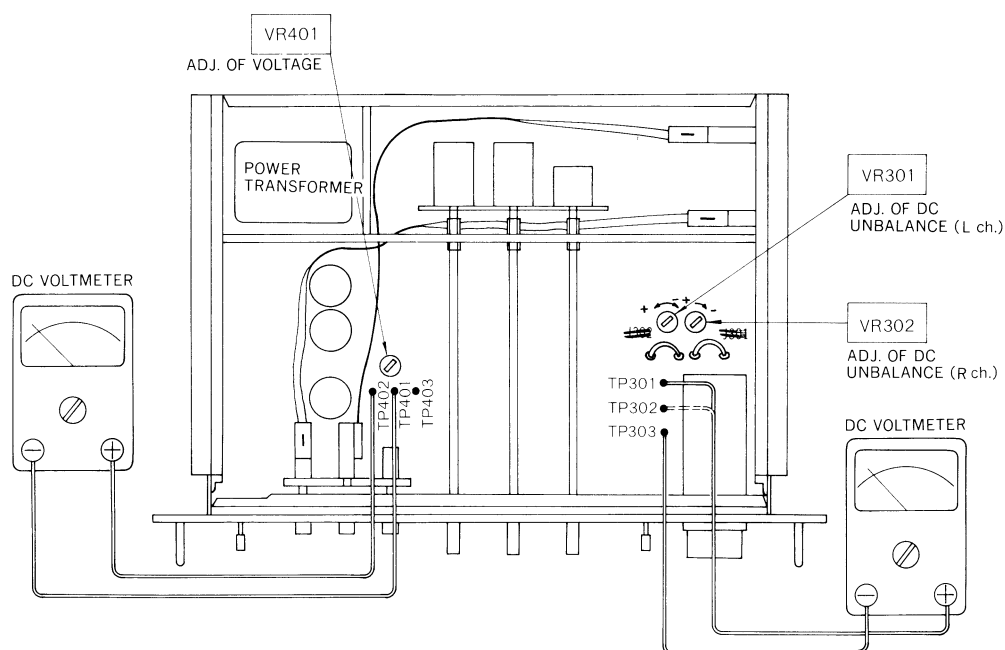

Fig. 1 (Abb. 1)

■ TO REMOVE THE REMOTE-SWITCH BANDS

1. Use a small screwdriver to push the projection of the remote-switch bands in the direction shown by the arrow in figure 2, and remove them from the remote switch.
2. When removing, remove ① in figure 3 first.
3. When attaching, attach ② in figure 3 first, and then install ①.
4. Check to be sure that the remote-switch bands are securely attached to the remote switch.

Note: When removing the remote-switch bands, be careful not to pull the bands nor to hold them as shown in © of figure 2, because to do so may result in damage. Also be careful not to bend or twist the bands excessively.

Note: When attaching the remote-switch bands to the remote switch, attach so that BAND ② is on the lower side. (Refer to fig. 4)

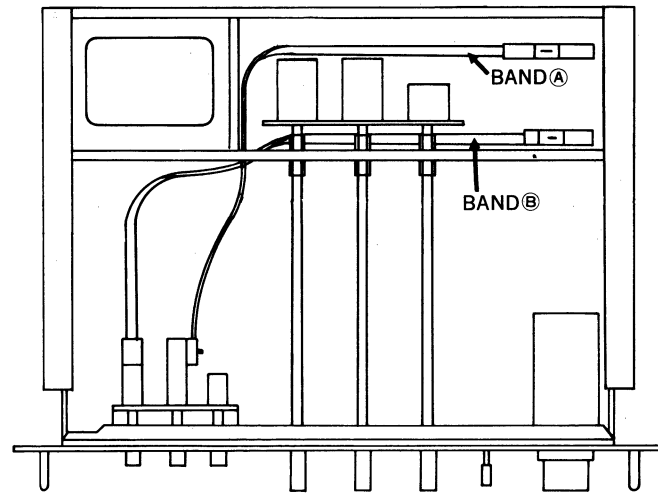

Fig. 4

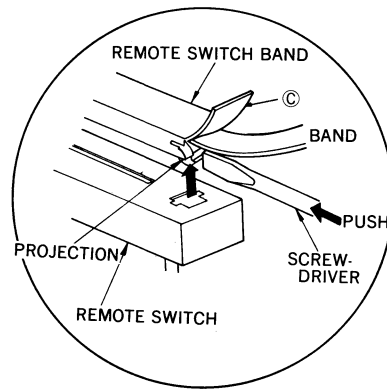

Fig. 2

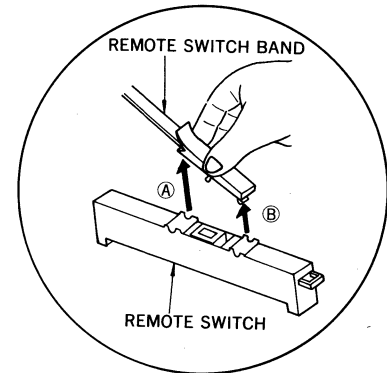
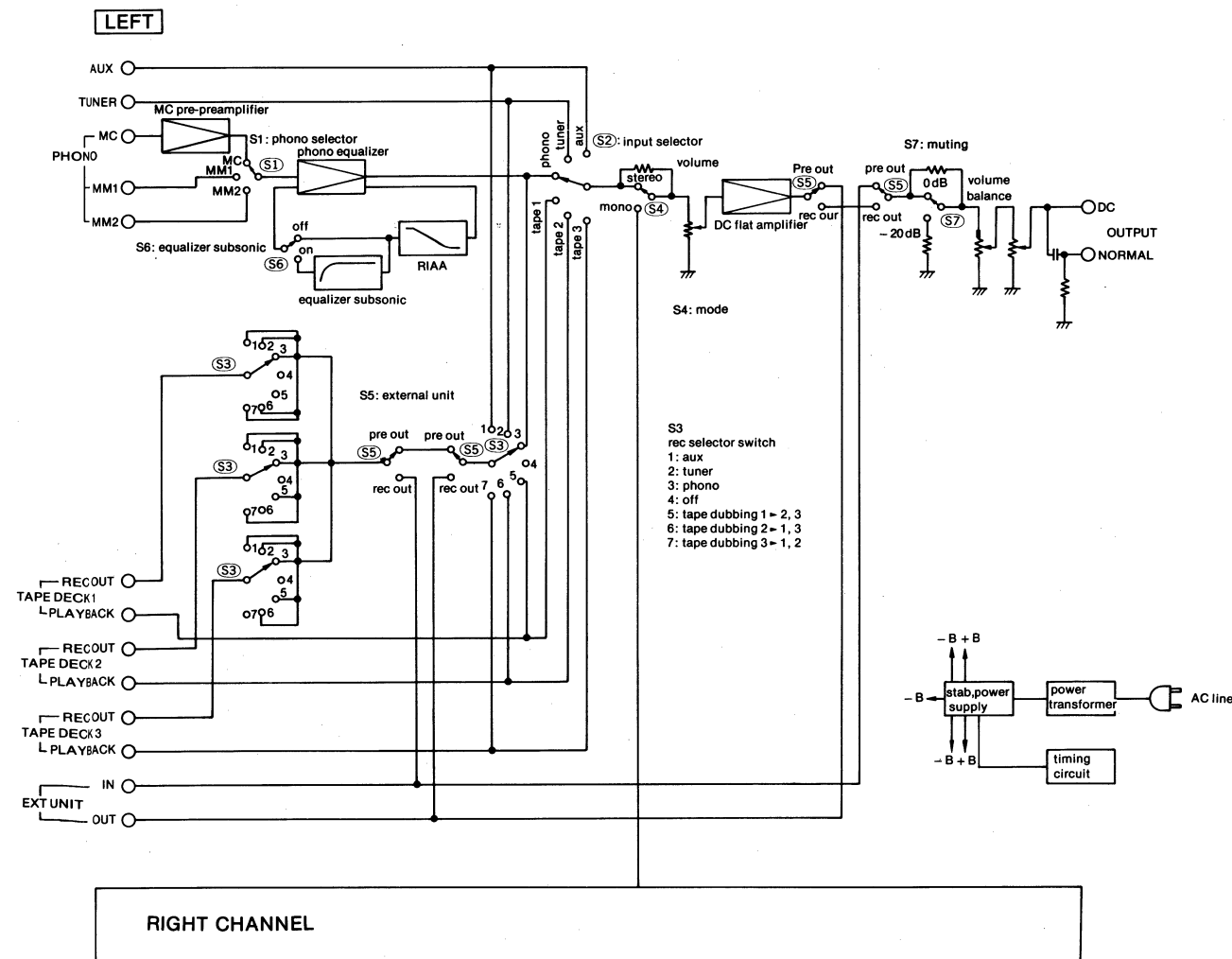
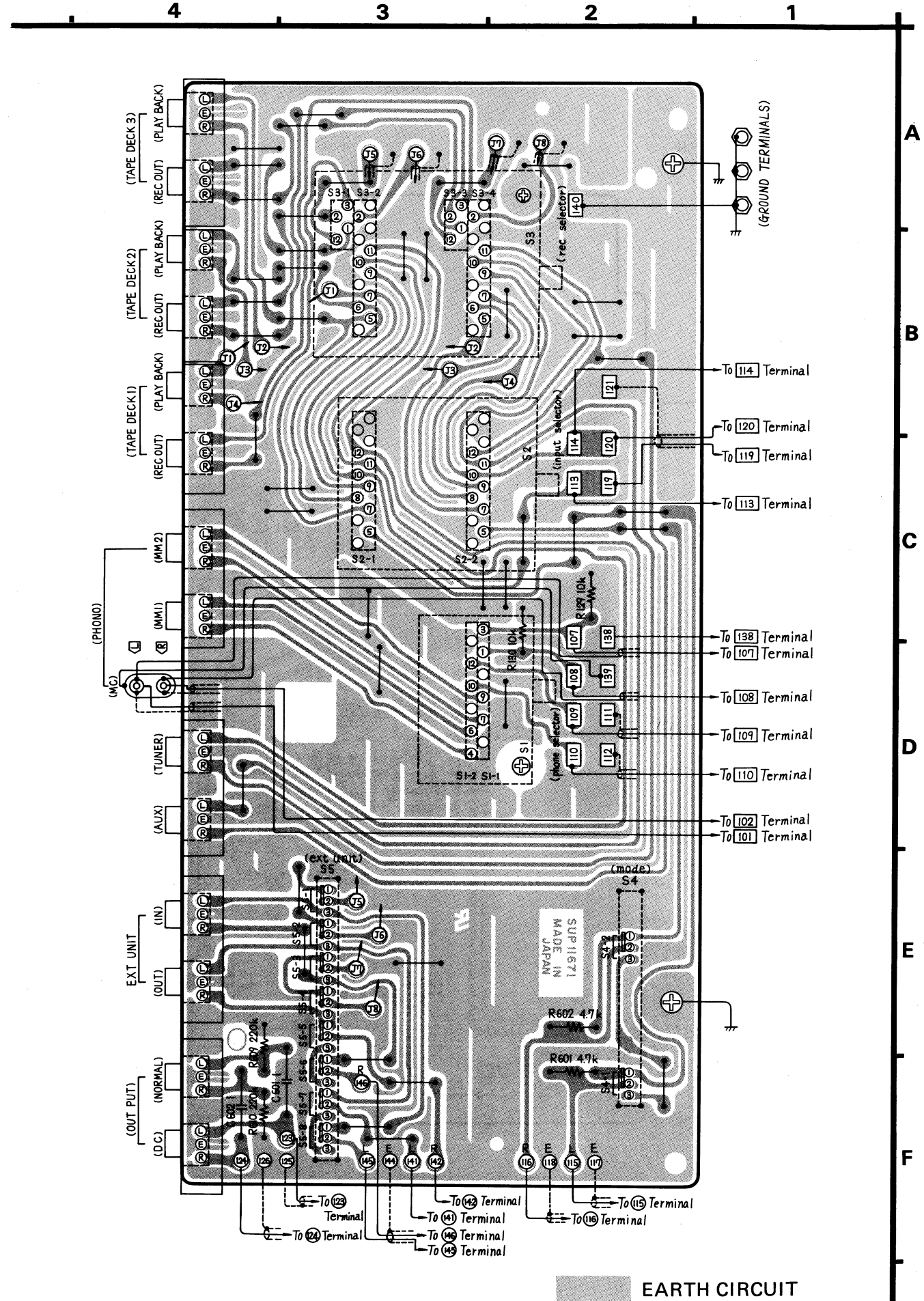

Fig. 3

■ BLOCK DIAGRAM



Printed Circuit Board Model SU-9070



A
B
C
D
E
F

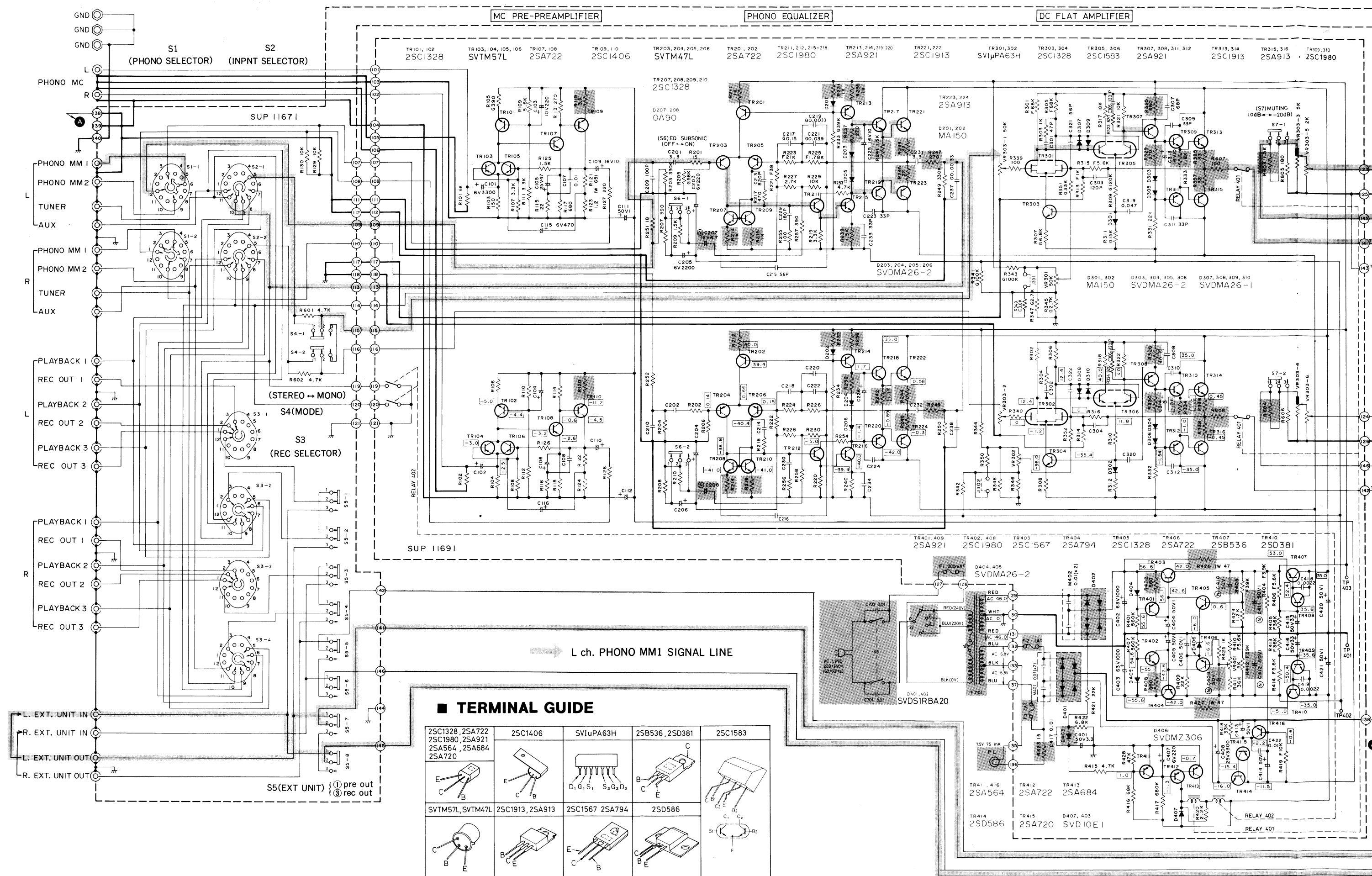

■ TERMINAL GUIDE

2SC1328, 2SA722 2SC1980, 2SA921 2SA564, 2SA684 2SA720	2SC1406	SV1uPA63H	2SB536, 2SD381	2SC1583
SVTM57L, SVTM47L	2SC1913, 2SA913	2SC1567, 2SA794	2SD586	

Schematic Diagram ... Model SU-9070

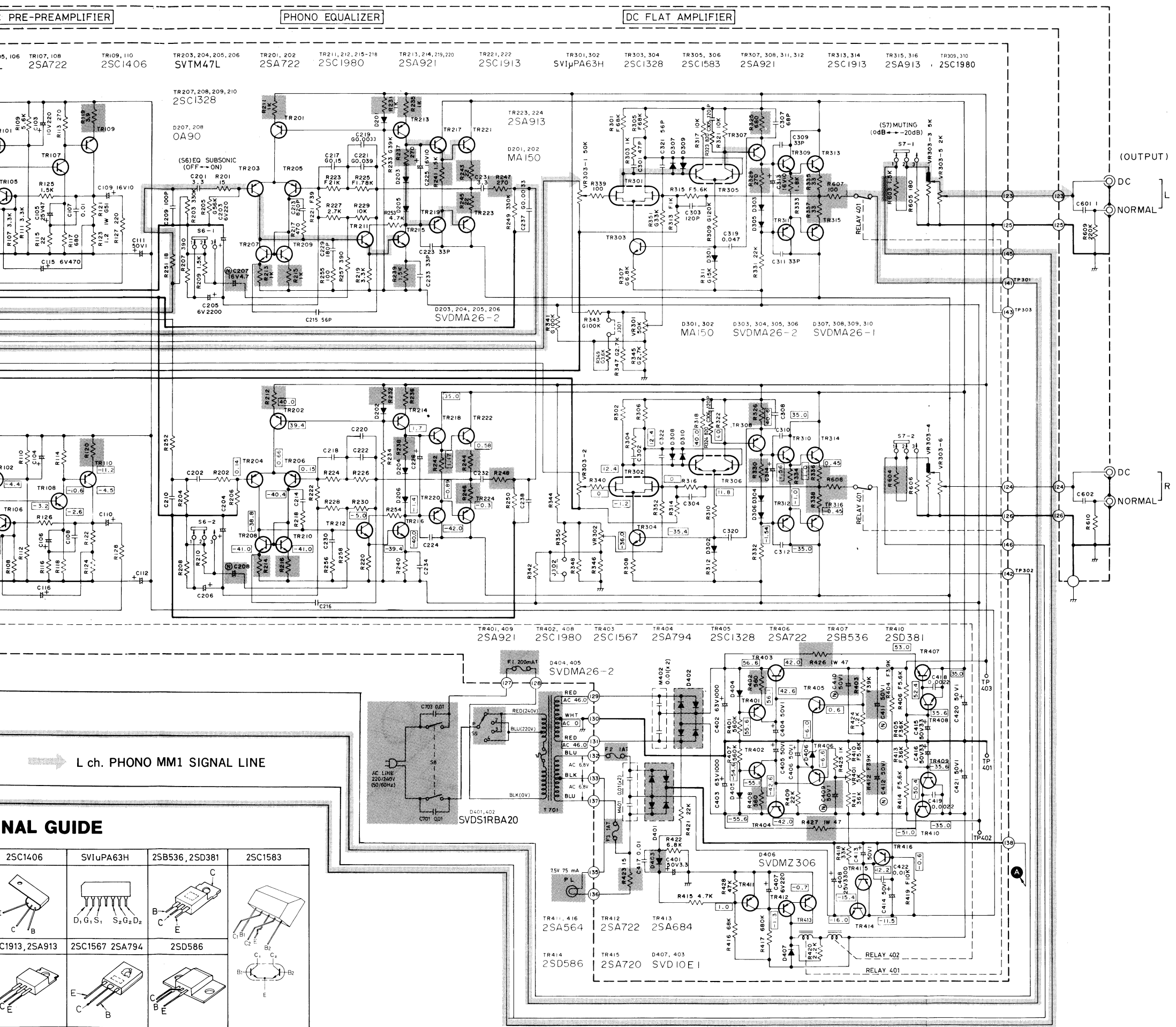

- Notes:**
- S1-1, S1-2: Phono selector switch in "MM1" position. (MC ↔ MM1 ↔ MM2)
 - S2-1, S2-2: Input selector switch in "phono" position. (tape 3 ↔ tape 2 ↔ tape 1 ↔ phono ↔ tuner ↔ aux)
 - S3-1 ~ S3-4: Recording selector switch in "off" position. (tape dubbing 3 ▶ 1,2 ↔ tape dubbing 2 ▶ 1,3 ↔ tape dubbing 1 ▶ 2,3 ↔ off ↔ phono ↔ tuner ↔ aux)
 - S4-1, S4-2: Mode switch in "stereo" position. (stereo ↔ mono)
 - S5-1 ~ S5-8: External unit switch in "pre out" position. (pre out ↔ rec out)
 - S6-1, S6-2: Equalizer subsonic filter switch in "off" position.
 - S7-1, S7-2: Muting switch in "0dB" position. (0dB ↔ -20dB)
 - S8: Power source switch in "off" position.
 - S9: Voltage selector switch in "240V" position.
 - Symbols indicating allowable deviation of resistors and capacitors: M: ±20% K: ±10% J: ±5% G: ±2% F: ±1%
 - The left and right channels use the same type of circuitry. The resistors, capacitors, etc. used for the right channel (circuit diagram below) are the same as for the left channel.
 - Resistors are 1/8W carbon-film resistors except as noted.
 - Indicated voltage values are the standard values for the unit measured by the DC electronic circuit tester (high impedance) with the chassis taken as standard. Therefore, there may exist some errors in the voltage values, depending on the internal impedance of the DC circuit tester.
 - This schematic diagram may be modified at any time with the development of new technology.

IMPORTANT SAFETY NOTICE
THE SHADED AREA ON THIS SCHEMATIC DIAGRAM INCORPORATES SPECIAL FEATURES IMPORTANT FOR SAFETY. WHEN SERVICING IT IS ESSENTIAL THAT ONLY MANUFACTURER'S SPECIFIED PARTS BE USED FOR THE CRITICAL COMPONENTS IN THE SHADED AREAS OF THE SCHEMATIC.

POWER SOURCE

• Only set for [XE]

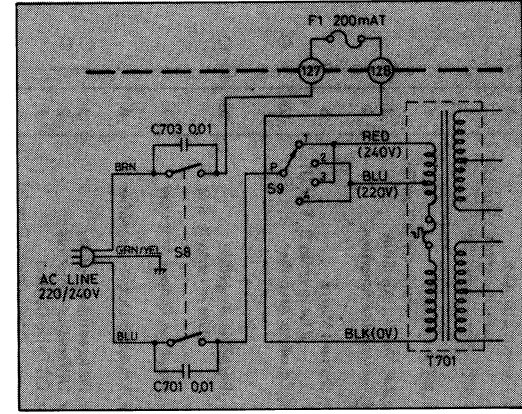

• Only set for [XM]

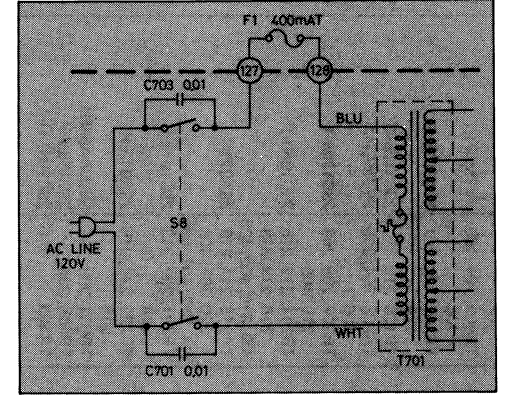

COMPONENT GUIDE

2SC1406	SV1uPA63H	2SB536, 2SD381	2SC1583
C1913, 2SA913	2SC1567 2SA794	2SD586	

■ CHANGE OF SCHEMATIC DIAGRAM FOR (XSD, XSW & XE)

■ EXPLODED VIEWS

(Addition of Diode)

**EQUALIZER
AMPLIFIER CIRCUIT**
(D210) is right channel.

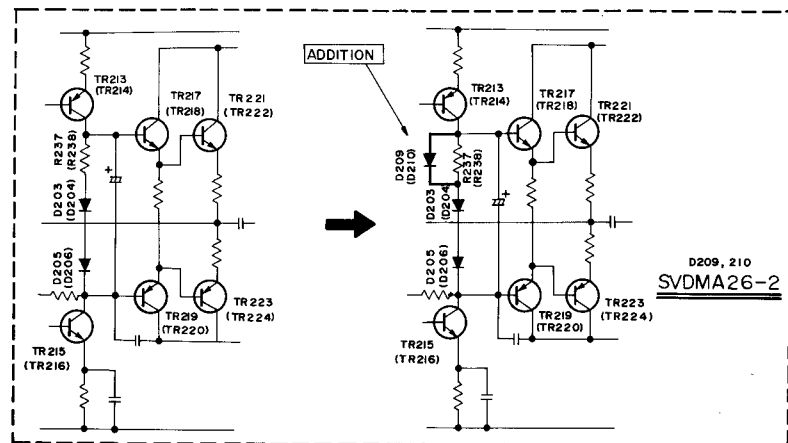

(Addition of Diode)

**DC FLAT
AMPLIFIER CIRCUIT**
(D312) is right channel.

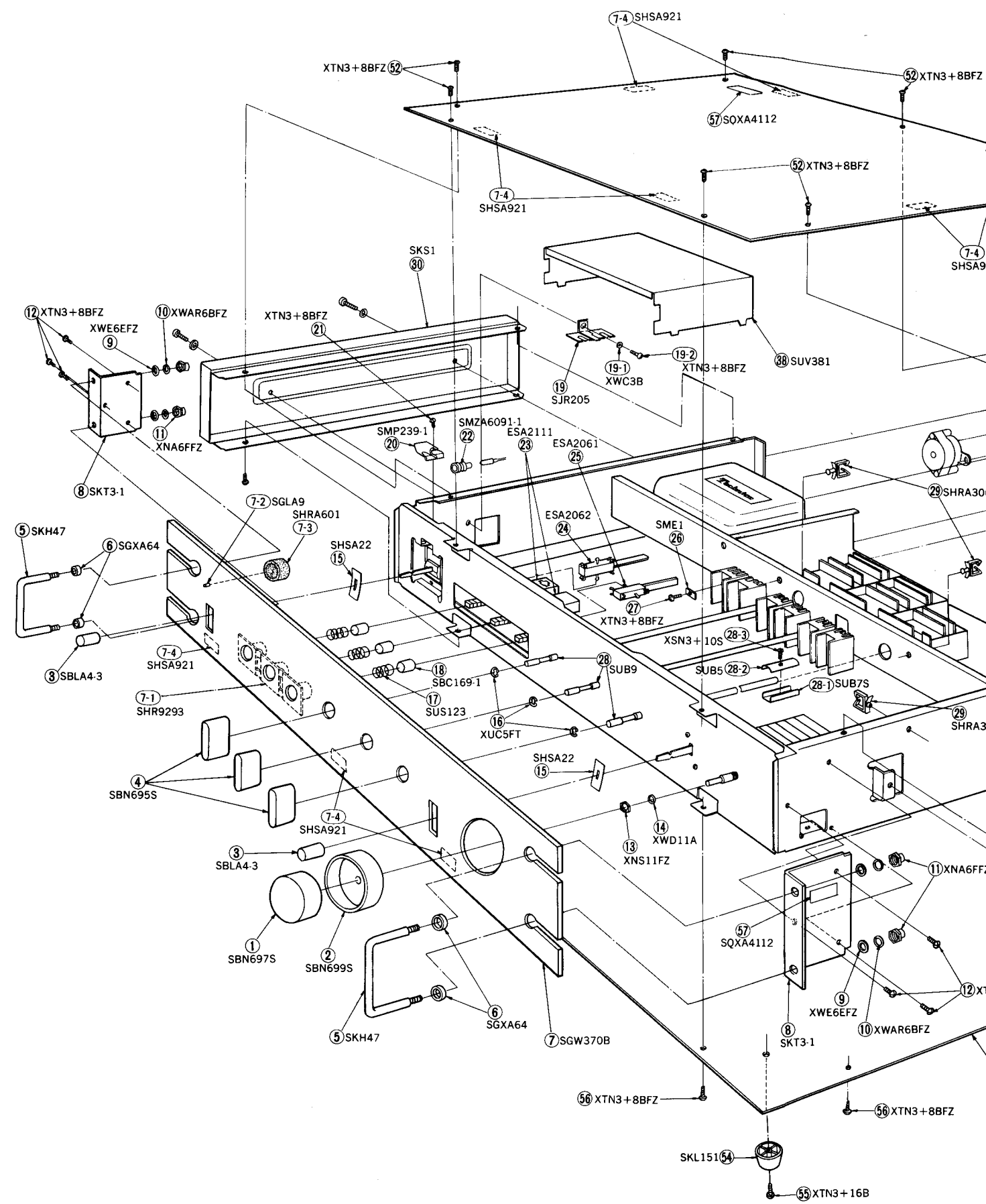
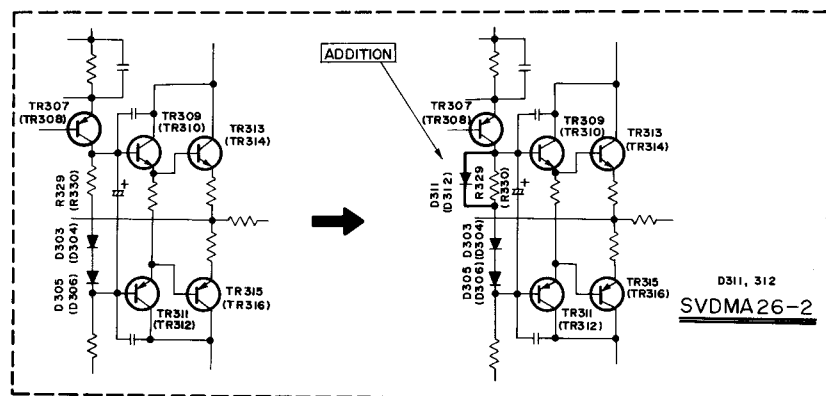

REPLACEMENT PARTS LIST

Important Safety Notice
Components identified by shaded areas have special characteristics important for safety. When replacing any of these components, use only the original manufacturer's specified parts.

NOTE: 1. Part numbers are indicated on most mechanical parts.
Please use this part number for parts orders.

Ref. No.	Part No.	Part Name & Description	Per Set	Remarks
TRANSISTORS				
TR101, 102, 303, 304	2SC1328-T	Transistor, Current Stabilizer (Use in ranks S, T or U)	4	
TR103, 104, 105, 106	SVTM57L	Transistor, Differential Amplifier	4	
TR107, 108, 201, 202	2SA902S-F	Transistor, MC Amplifier (Use in ranks F or G)	4	
TR109, 110, 203, 204, 205, 206	2SC1406-Q	Transistor, MC Output Amplifier	2	
TR207, 208, 209, 210, 405	2SC1328-T	Transistor, Current Mirror (Use in ranks S, T or U)	5	
TR211, 212, 215, 216, 217, 218, 309, 310, 402, 408	2SC1980-T	Transistor, Equalizer Amplifier	10	
TR213, 214, 219, 220, 307, 308, 311, 312, 401, 409, 414	2SA921-T	Transistor, Equalizer Output Amplifier (Use in ranks R, S or T)	4	
TR221, 222, 313, 314	2SC1913-R	Transistor, Equalizer Output Amplifier	4	
TR223, 224, 315, 316	2SA913-R	Transistor, Equalizer Output Amplifier	4	
TR301, 302, TR305, 306, TR403	SVLUPA63H1	Transistor, Differential Amplifier	2	
TR307, 308, TR404	2SC1567-Q	Transistor, DC Drive Control (Use in ranks Q or R)	1	
TR406, 412	2SA794-Q	Transistor, DC Drive Control (Use in ranks Q or R)	1	
TR407	2SA902S-F	Transistor, DC Det & Muting (Use in ranks F or G)	2	
TR410	2SB8536-L	Transistor, Voltage Regulator (Use in ranks L or M)	1	
TR411, 416, TR413, TR414, TR415	2SD391-L	Transistor, Voltage Regulator (Use in ranks L or M)	1	
	2SA666A1-R	Transistor, Muting (Use in ranks Q, R or S)	2	
	2SA752-Q	Transistor, Muting (Use in ranks Q, R or S)	1	
	2SD586-R	Transistor, Voltage Stabilizer (Use in ranks Q, R or S)	1	
	2SA720-R	Transistor, Voltage Regulator (Use in ranks Q, R or S)	1	
DIODES				
D201, 202, 301, 302	MA150	Diode	4	
D203, 204, 205, 206, 303, 304, 305, 306, 404, 405	SVDMA26-2	Diode	10	
D209, 210, 311, 312 [XSD, XSW, XE] only	SVDMA26-2	Diode	4	
D307, 308, 309, 310	SVDMA26-1	Diode	4	

EXPLODED VIEWS

Available in (XM) only

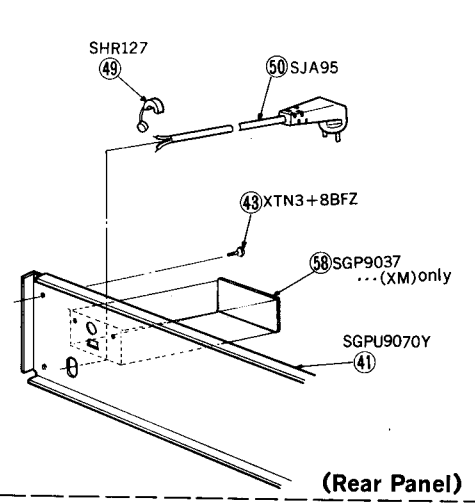
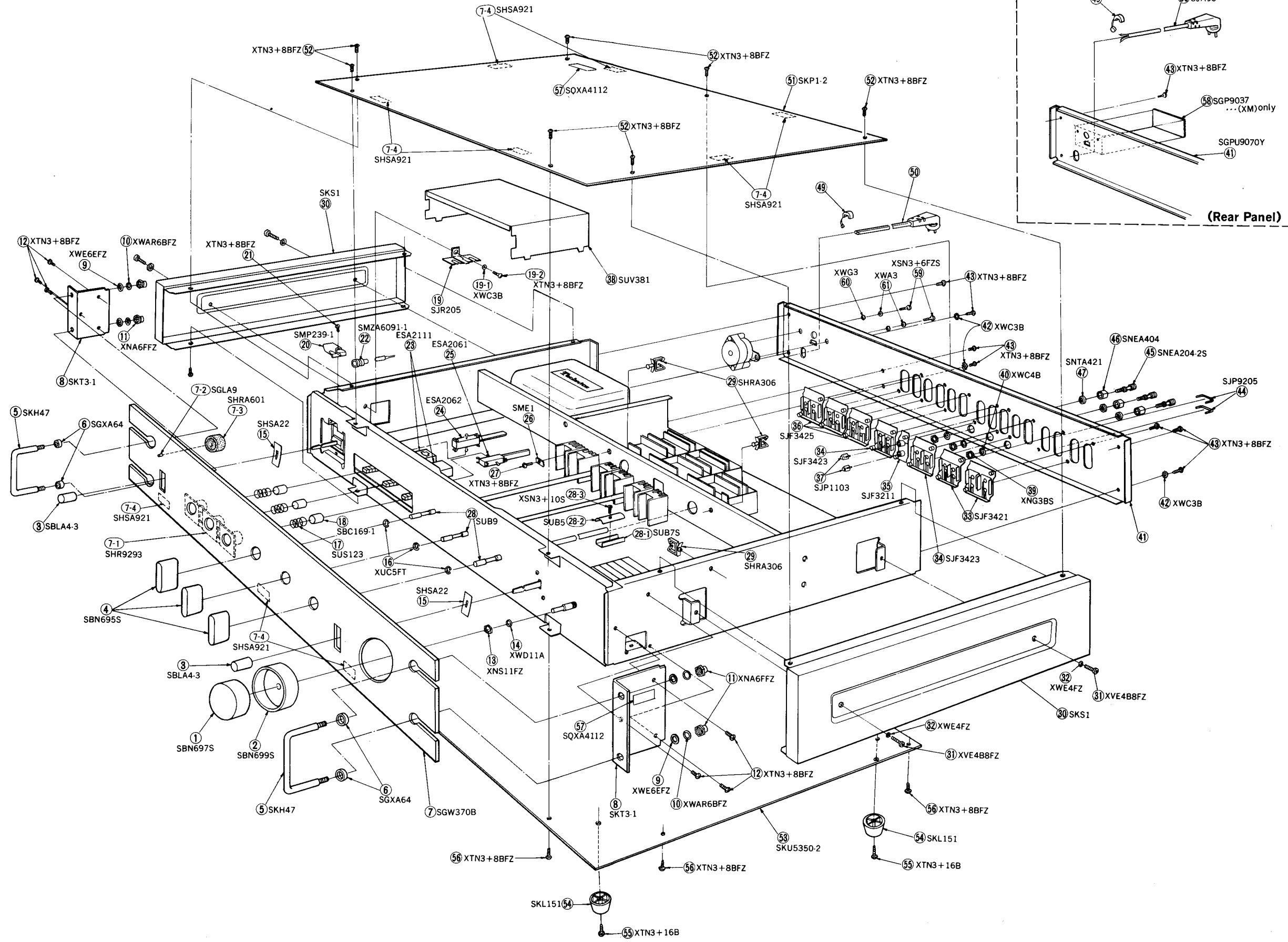

D209, 210
SVDMA26-2

D311, 312
SVDMA26-2

Diode
Diode

SVDMA26-2
SVDMA26-1

305, 306, 404
405
D209, 210, 311
312 [XSD, XSW,
XE] only
D307, 308, 309
310

13 SU-9070

14 SU-9070

Ref. No.	Part No.	Part Name & Description	Per Set	Remarks
D401, 402	SVDSIRBA20	Rectifier	2	
D403, 407	SVD10E1	Diode, Switching	2	
D406	SVDMZ306	Diode, Switching	1	
TRANSFORMER				
T701	SLT7G5-I	Power Transformer (Except set for [XE], [XM])	1	○
T701 [XE] only	SLT7G7-I	Power Transformer	1	○
T701 [XM] only	SLT7G3-I	Power Transformer	1	○
RESISTORS				
R101, 102	ERD25TJ680	Carbon, 68Ω, 1/4W, ± 5%	2	
R103, 104	ERD25TJ151	Carbon, 150Ω, 1/4W, ± 5%	2	
R105, 106	ERO25CKG3900	Carbon, 390Ω, 1/4W, ± 2%	2	
R107, 108	ERD25TJ332	Carbon, 3.3kΩ, 1/4W, ± 5%	2	
R109, 110	ERD25TJ562	Carbon, 5.6kΩ, 1/4W, ± 5%	2	
R111, 112	ERD25TJ332	Carbon, 3.3kΩ, 1/4W, ± 5%	2	
R113, 114	ERD25TJ271	Carbon, 270Ω, 1/4W, ± 5%	2	
R115, 116	ERD25TJ220	Carbon, 22Ω, 1/4W, ± 5%	2	
R117, 118	ERD25TJ681	Carbon, 680Ω, 1/4W, ± 5%	2	
R119, 120	ERD14FJ3R9	Carbon, 3.9Ω, 1/4W, ± 5%	2	
R121, 122	ERG1ANG510	Metal Film, 51Ω, 1W, ± 2%	2	
R123, 124	ERX12ANJ1R2	Metal Film, 1.2Ω, 1/2W, ± 5%	2	
R125, 126	ERD25TJ152	Carbon, 1.5kΩ, 1/4W, ± 5%	2	
R127, 128	ERD25TJ221	Carbon, 220Ω, 1/4W, ± 5%	2	
R129, 130	ERD25TJ103	Carbon, 10kΩ, 1/4W, ± 5%	2	
R201, 202	ERD25TJ150	Carbon, 15Ω, 1/4W, ± 5%	2	
R203, 204	ERD25TJ334	Carbon, 330kΩ, 1/4W, ± 5%	2	
R205, 206	ERO25CKG5602	Metal Film, 56kΩ, 1/4W, ± 2%	2	
R207, 208	ERD25TJ391	Carbon, 390Ω, 1/4W, ± 5%	2	
R209, 210	ERD25TJ152	Carbon, 1.5kΩ, 1/4W, ± 5%	2	
R211, 212	ERQ12HJ102	Fuse Type Metallic, 1kΩ, 1/2W, ± 5%	2	
R213, 214	ERQ12HJ102	Fuse Type Metallic, 1kΩ, 1/2W, ± 5%	2	
R215, 216	ERQ12HJ102	Fuse Type Metallic, 1kΩ, 1/2W, ± 5%	2	
R217, 218	ERD25TJ471	Carbon, 470Ω, 1/4W, ± 5%	2	
R219, 220	ERD25TJ332	Carbon, 3.3kΩ, 1/4W, ± 5%	2	
R221, 222	ERO25CKF39R0	Metal Film, 39Ω, 1/4W, ± 1%	2	
R223, 224	ERO25CKF2102	Metal Film, 21kΩ, 1/4W, ± 1%	2	
R225, 226	ERO25CKF1781	Metal Film, 1.78kΩ, 1/4W, ± 1%	2	
R227, 228	ERD25TJ272	Carbon, 2.7kΩ, 1/4W, ± 5%	2	
R229, 230	ERD25TJ103	Carbon, 10kΩ, 1/4W, ± 5%	2	
R231, 232	ERQ12HJ102	Fuse Type Metallic, 1kΩ, 1/2W, ± 5%	2	
R233, 234	ERO25CKG3902	Metal Film, 39kΩ, 1/4W, ± 2%	2	
R235, 236	ERQ12HJ102	Fuse Type Metallic, 1kΩ, 1/2W, ± 5%	2	
R237, 238	ERD14FJ271	Carbon, 270Ω, 1/4W, ± 5%	2	
R239, 240	ERQ12HJ152	Fuse Type Metallic, 1.5kΩ, 1/2W, ± 5%	2	
R241, 242	ERD14FJ152	Carbon, 1.5kΩ, 1/4W, ± 5%	2	
R243, 244	ERQ12HJ220	Fuse Type Metallic, 22Ω, 1/2W, ± 5%	2	
R245, 246	ERQ12HJ220	Fuse Type Metallic, 22Ω, 1/2W, ± 5%	2	
R247, 248	ERD14FJ271	Carbon, 270Ω, 1/4W, ± 5%	2	
R249, 250	ERD25TJ334	Carbon, 330kΩ, 1/4W, ± 5%	2	
R251, 252	ERD25TJ180	Carbon, 18Ω, 1/4W, ± 5%	2	
R253, 254	ERD25TJ472	Carbon, 4.7kΩ, 1/4W, ± 5%	2	
R255, 256	ERD25TJ101	Carbon, 100Ω, 1/4W, ± 5%	2	
R257, 258	ERD25TJ391	Carbon, 390Ω, 1/4W, ± 5%	2	

Ref. No.	Part No.	Part Name & Description	Per Set	Remarks
R301, 302	ERO25CKF6802	Metal Film, 68kΩ, 1/4W, ± 1%	2	
R303, 304	ERD25TJ102	Carbon, 1kΩ, 1/4W, ± 5%	2	
R305, 306	ERO25CKF6802	Metal Film, 68kΩ, 1/4W, ± 1%	2	
R307, 308	ERO25CKG6801	Metal Film, 6.8kΩ, 1/4W, ± 2%	2	
R309, 310	ERO25CKG1203	Metal Film, 120kΩ, 1/4W, ± 2%	2	
R311, 312	ERO25CKG1502	Metal Film, 15kΩ, 1/4W, ± 2%	2	
R313, 314	ERO25CKF1001	Metal Film, 1kΩ, 1/4W, ± 1%	2	
R315, 316	ERO25CKF5601	Metal Film, 5.6kΩ, 1/4W, ± 1%	2	
R317, 318	ERD25TJ103	Carbon, 10kΩ, 1/4W, ± 5%	2	
R321, 322	ERD25TJ103	Carbon, 10kΩ, 1/4W, ± 5%	2	
R323, 324	ERD25TJ821	Carbon, 820Ω, 1/4W, ± 5%	2	
R325, 326	ERD14FJ681	Carbon, 680Ω, 1/4W, ± 5%	2	
R329, 330	ERD14FJ271	Carbon, 270Ω, 1/4W, ± 5%	2	
R331, 332	ERD25TJ223	Carbon, 22kΩ, 1/4W, ± 5%	2	
R333, 334	ERD14FJ182	Carbon, 1.8kΩ, 1/4W, ± 5%	2	
R335, 336	ERQ12HJ330	Fuse Type Metallic, 33Ω, 1/2W, ± 5%	2	
R337, 338	ERQ12HJ330	Fuse Type Metallic, 33Ω, 1/2W, ± 5%	2	
R339, 340	ERD25TJ101	Carbon, 100Ω, 1/4W, ± 5%	2	
R341, 342	ERO25CKG1003	Metal Film, 100kΩ, 1/4W, ± 2%	2	
R343, 344	ERO25CKG1003	Metal Film, 100kΩ, 1/4W, ± 2%	2	
R345, 346	ERO25CKG2701	Metal Film, 2.7kΩ, 1/4W, ± 2%	2	
R347, 348	ERO25CKG2701	Metal Film, 2.7kΩ, 1/4W, ± 2%	2	
R349, 350	ERO25CKG3601	Metal Film, 3.6kΩ, 1/4W, ± 2%	2	
R351, 352	ERO25CKG3302	Metal Film, 33kΩ, 1/4W, ± 2%	2	
R401	ERD25TJ564	Carbon, 560kΩ, 1/4W, ± 5%	1	
R402	ERD14FJ561	Carbon, 560Ω, 1/4W, ± 5%	1	
R403, 404	ERO25CKF3902	Metal Film, 39kΩ, 1/4W, ± 1%	2	
R405	ERO25CKF3602	Metal Film, 36kΩ, 1/4W, ± 1%	1	
R406	ERO25CKF5601	Metal Film, 5.6kΩ, 1/4W, ± 1%	1	
R407	ERD25TJ564	Carbon, 560kΩ, 1/4W, ± 5%	1	
R408	ERD14FJ561	Carbon, 560Ω, 1/4W, ± 5%	1	
R409	ERD25TJ223	Carbon, 22kΩ, 1/4W, ± 5%	1	
R410	ERO25CKF5601	Metal Film, 5.6kΩ, 1/4W, ± 1%	1	
R411	ERO25CKF3602	Metal Film, 36kΩ, 1/4W, ± 1%	1	
R412	ERO25CKF3902	Metal Film, 39kΩ, 1/4W, ± 1%	1	
R413	ERO25CKF3602	Metal Film, 36kΩ, 1/4W, ± 1%	1	
R414	ERO25CKF5601	Metal Film, 5.6kΩ, 1/4W, ± 1%	1	
R415	ERD25TJ472	Carbon, 4.7kΩ, 1/4W, ± 5%	1	
R416	ERD25TJ683	Carbon, 68kΩ, 1/4W, ± 5%	1	
R417	ERD25TJ684	Carbon, 680kΩ, 1/4W, ± 5%	1	
R418	ERD25TJ333	Carbon, 33kΩ, 1/4W, ± 5%	1	
R419	ERO25CKF1002	Metal Film, 10kΩ, 1/4W, ± 1%	1	
R420	ERD25TJ222	Carbon, 2.2kΩ, 1/4W, ± 5%	1	
R421	ERD25TJ223	Carbon, 22kΩ, 1/4W, ± 5%	1	
R422	ERD25TJ682	Carbon, 6.8kΩ, 1/4W, ± 5%	1	
R423	ERD18FJ150	Carbon, 15Ω, 1/8W, ± 5%	1	
R424	ERD25TJ122	Carbon, 1.2kΩ, 1/4W, ± 5%	1	
R425	ERD25TJ102	Carbon, 1kΩ, 1/4W, ± 5%	1	
R426, 427	ERQ1CJ470	Fuse Type Metallic, 47Ω, 1W, ± 5%	2	
R428	ERD25TJ473	Carbon, 47kΩ, 1/4W, ± 5%	1	
R601, 602	ERD25TJ472	Carbon, 4.7kΩ, 1/4W, ± 5%	2	
R603, 604	ERD14FJ152	Carbon, 1.5kΩ, 1/4W, ± 5%	2	
R605, 606	ERD25TJ181	Carbon, 180Ω, 1/4W, ± 5%	2	
R607, 608	ERD14FJ101	Carbon, 100Ω, 1/4W, ± 5%	2	
R609, 610	ERD25TJ224	Carbon, 220kΩ, 1/4W, ± 5%	2	

Ref. No.	Part No.	Part Name & Description	Per Set	Remarks
VARIABLE RESISTORS				
VR301, 302	EVMR4AA00B54	DC Unbalance Adjustment 50kΩ (B)	2	○
VR303	EWCFPAS20ATD	Balance and Volume Control 5kΩ, 2kΩ, 50kΩ (ATT)	1	
VR401	EVTR4AA00B53	Voltage Adjustment 5kΩ (B)	1	
CAPACITORS				
C101, 102	ECEA6A332	Electrolytic, 3300μF, 6.3V	2	
C103, 104	ECEA10A220	Electrolytic, 220μF, 10V	2	
C105, 106	ECEA25A47	Electrolytic, 47μF, 25V	2	
C107, 108	ECKD1H103ZF	Ceramic, 0.01μF, 50V, ^{+80%} _{-20%}	2	
C109, 110	ECEA16M10R	Electrolytic, 10μF, 16V	2	
C111, 112	ECEA50V1	Electrolytic, 1μF, 50V	2	
C115, 116	ECEA6A470	Electrolytic, 470μF, 6.3V	2	
C201, 202	ECQE1335KZ	Polyester, 3.3μF, 100V, ±10%	2	
C203, 204	ECEA6A220	Electrolytic, 220μF, 6.3V	2	
C205, 206	ECEA6A222	Electrolytic, 2200μF, 6.3V	2	
C207, 208	ECEA25N4R7	Non-Polar Electrolytic, 4.7μF, 25V	2	
C209, 210	ECCD1H101K	Ceramic, 100pF, 50V, ±10%	2	
C213, 214	ECKD1H821KB	Ceramic, 820pF, 50V, ±10%	2	
C215, 216	ECCD2H560K	Ceramic, 56pF, 500V, ±10%	2	
C217, 218	ECQF05154GZN	Polypropylene, 0.15μF, 50V, ±2%	2	
C219, 220	ECQF1332GZN	Polypropylene, 0.0033μF, 100V, ±2%	2	
C221, 222	ECQF1393GZN	Polypropylene, 0.039μF, 100V, ±2%	2	
C223, 224	ECCD2H330K	Ceramic, 33pF, 500V, ±10%	2	
C225, 226	ECEA16V10	Electrolytic, 10μF, 16V	2	
C229, 230	ECCD1H181K	Ceramic, 180pF, 50V, ±10%	2	
C231, 232	ECQE1335KZ	Polyester, 3.3μF, 100V, ±10%	2	
C233, 234	ECCD1H330K	Ceramic, 33pF, 50V, ±10%	2	
C237, 238	ECQF1332GZN	Polypropylene, 0.0033μF, 100V, ±2%	2	
C301, 302	ECCD1H470K	Ceramic, 47pF, 50V, ±10%	2	
C303, 304	ECCD1H121K	Ceramic, 120pF, 50V, ±10%	2	
C305, 306	ECCD1H121K	Ceramic, 120pF, 50V, ±10%	2	
C307, 308	ECCD1H680K	Ceramic, 68pF, 50V, ±10%	2	
C309, 310	ECCD2H330K	Ceramic, 33pF, 500V, ±10%	2	
C311, 312	ECCD2H330K	Ceramic, 33pF, 500V, ±10%	2	
C313, 314	ECEA16V10	Electrolytic, 10μF, 16V	2	
C319, 320	ECQM1473KZ	Polyester, 0.047μF, 100V, ±10%	2	
C321, 322	ECCD1H560K	Ceramic, 56pF, 50V, ±10%	2	
C401	ECEA50V3R3	Electrolytic, 3.3μF, 50V	1	
C402, 403	ECET63R102SL	Electrolytic, 1000μF, 63V	2	
C404, 405	ECEA50V1	Electrolytic, 1μF, 50V	2	
C406	ECEA50V1	Electrolytic, 1μF, 50V	1	
C407	ECEA6A220	Electrolytic, 220μF, 6.3V	1	
C408	ECET25R332SL	Electrolytic, 3300μF, 25V	1	
C409, 410	ECEA50N1	Non-Polar Electrolytic, 1μF, 50V	2	
C411, 412	ECEA50N1	Non-Polar Electrolytic, 1μF, 50V	2	
C413, 414	ECEA50V1	Electrolytic, 1μF, 50V	2	
C415, 416	ECEA50A33	Electrolytic, 33μF, 50V	2	
C417	ECKD1H103ZF	Ceramic, 0.01μF, 50V, ^{+80%} _{-20%}	1	
C418, 419	ECKD1H222ZF	Ceramic, 0.0022μF, 50V, ^{+80%} _{-20%}	2	
C420, 421	ECEA50V1	Electrolytic, 1μF, 50V	2	
C422	ECKD1H103ZF	Ceramic, 0.01μF, 50V, ^{+80%} _{-20%}	1	
C601, 602	ECQE1105K	Polyester, 1μF, 100V, ±10%	2	
C701	ECNC4A103M	Paper, 0.01μF, 450V, AC, ±20%	1	

Ref. No.	Part No.	Part Name & Description	Per Set	Remarks
C703	ECNC4A103M	Paper, 0.01μF, 450V, AC, ±20%	1	
FUSES				
F1	XBA2C02TR0	Fuse, 200mA (250V), Power Source	1	
F1 [XM] only	XBA2C04TR0	Fuse, 400mA (250V), Power Source	1	
F2, 3	XBA2C10TR0	Fuse, 1AT (250V), Power Source	1	
PILOT LAMP				
PL1	XAM37T500	Power Indicator, 7.5V-75mA	1	○
SWITCHES				
S1	SSR69	Switch, Phono Selector	1	○
S2	SSR71	Switch, Input Selector	1	○
S3	SSR73	Switch, Recording Selector	1	○
S4	ESD8056	Switch, Mode Selector	1	○
S5	ESD80153	Switch, Ext Unit	1	○
S6	LSB7152	Switch, Equalizer Subsonic Filter	1	
S7	SSL735	Switch, Muting	1	
S8	SSL115	Switch, Power	1	
S9	SSR87S	Switch, Voltage Selector (Except set for [XM])	1	
COMPONENT COMBINATIONS				
M401, 402	RXAF103P22HD	Component Combination, 0.01μF (X2)	2	
RELAYS				
RLY401	SSY9	Relay, Muting	1	○
RLY402	SSY31	Relay, Muting	1	
CABINET and CHASSIS PARTS				
1	SBN697S	Knob, Volume Control	1	○
2	SBN699S	Knob, Balance Control	1	
3	SBLA4-3	Knob, Muting & Power Switches	2	
4	SBN695S	Knob, Selector Switches	3	
5	SKH47	Handle, Front Panel	2	
6	SGXA64	Sleeve, Handle	4	
7	SGW370B	Panel, Front	1	
7-1	SHR9293	Sleeve, Push Switch Buttons	1	
7-2	SGLA9	Panel Light, Orange	1	
7-3	SHRA601	Bracket, Lamps	1	
7-4	SHSA921	Paper Cloth	9	
8	SKT3-1	Bracket, Handle	2	
9	XWE6EFZ	Washer, Handle	4	
10	XWAR6BFZ	Washer (Spring), Handle	4	
11	XNA6FFZ	Nut, Handle M'tg	4	
12	XTN3+8BFZ	Screw, Handle Bracket M'tg	6	
13	XNS11FZ	Nut, Volume Control M'tg	1	
14	XWD11A	Washer (Spring), Volume Control	1	
15	SHSA22	Shading Cloth	2	
16	XUC5FT	Circlip, Selector Switches Shaft M'tg	6	
17	SUS123	Spring, Push Switches	3	

Ref. No.	Part No.	Part Name & Description	Per Set	Remarks
18	SBC169-1	Button, Mode, Ext Unit and Equalizer Subsonic	3	
19	SJR205	Terminal Strip	1	
19-1	XWC3B	Washer, Terminal Strip Screw	2	
19-2	XTN3+8BFZ	Screw, Terminal Strip M'tg	1	
20	SMP239-1	Bracket, Lamp	1	* O
21	XTN3+8BFZ	Screw, Lamp Bracket M'tg	1	
22	SMZA6091-1	Bracket, Lamp	1	*
23	ESA2111	Switch, Remote	2	O
24	ESA2062	Wire, Remote Switch	1	
25	ESA2061	Wire, Remote Switch	1	O
26	SME1	Bracket, Transistor	6	*
27	XTN3+8BFZ	Screw, Transistor Bracket M'tg	6	
28	SUB9	Shaft, Selector Switch	3	O
28-1	SUB7S	Coupler, Selector Switch Shaft	3	
28-2	SUB5	Coupler, Selector Switch Shaft	3	
28-3	XSN3+10S	Switch, Shaft Coupling M'tg	3	
29	SHRA306	Clamp, Lead Wires	3	
30	SKS1	Side Board	2	*
31	XVE468FZ	Bolt, Side Board M'tg	4	
32	XWE4FZ	Washer, Side Board M'tg	4	
33	SJF3421	Terminal, Out Put and Ext Unit	2	O
34	SJF3423	Terminal, Aux, Tuner, MM1 and MM2	2	O
35	SJF3211	Terminal, Phono (MC)	1	O
36	SJF3425	Terminal, Tape Deck1, Tape Deck2 and Tape Deck3	3	O
37	SJP1103	Pin Plug	2	O
38	SUV381	Cover, Shield	1	* O
39	XNG3BS	Nut, Ground Terminal M'tg	3	
40	XWC4B	Washer (Spring), Ground Terminal Nut	3	
41	SGP96-2A	Rear Panel, (Except set for [XSD, XSW], [XM] and [XE])	1	O
41 [XSD, XSW] only	SGPU9070D	Rear Panel, SGP96-2A with Name Plate (SGT14890)	1	O
41 [XM] only	SGPU9070Y	Rear Panel, SGP96-2A with Name Plate (SGT15730)	1	O
41 [XE] only	SGP96-3A	Rear Panel	1	O
42	XWC3B	Washer, Rear Panel Screw	3	
43	XTN3+8BFZ	Screw, Rear Panel and Terminal M'tg	22	
44	SJP9205	Short, Pin	2	
45	SNEA204-2S	Terminal, Ground	3	
46	SNEA404	Nut, Ground Terminal M'tg	3	
47	SNTA421	Bracket, Ground Terminal	3	
49	SHR127	Bushing, AC cord (Except set for [XE])	1	
49 [XE] only	SHR131	Bushing, AC Cord	1	
50 [X, XG, XGF, XM]	SJA95	AC Cord, with Plug	1	
50 [XGH, XSD]	SJA81	AC Cord, with Plug	1	
50 [XSW]	SJA68	AC Cord, with Plug	1	
50 [XE]	SJA73	AC Cord	1	
51	SKP1-2	Top Board	1	O
52	XTN3+8BFZ	Screw, Top Board M'tg	7	
53	SKU5350-2	Bottom Board	1	* O
54	SKL151	Foot, Bottom Board	4	
55	XTN3+16B	Screw, Foot M'tg	4	
56	XTN3+8BFZ	Screw, Bottom Board M'tg	7	
57	SQXA4112	Caution Label, Cabinet Screw	3	
58 [XM] only	SGP9037	Cover Plate, Hole	1	O
59	XSN3+6FZS	Screw, Voltage Selector Switch M'tg	2	

Ref. No.	Part No.	Part Name & Description	Per Set	Remarks
60 61	XWG3 XWA3	Washer, Voltage Selector Switch Washer (Spring), Voltage Selector Switch Screw	2 2	
ACCESSORIES				
A1	SJP2129	Cord, Connection Shield	1	
A2 [X, XM] only	SJP5213	Plug Adaptor, AC Power	1	
A3 [X, XM] only	SJP5215	Plug Adaptor, AC Power	1	
A4	RJP5	Pin Plug	4	
A5	SKL117	Foot, Adapter	4	
A6	XTN3+8B XWG3	Screw, Adapter Foot M'tg Washer, Adapter Foot Screw	4	
PACKING PARTS				
P1	SPP495	Soft Cover	1	
P2	SPS109-1	Pad, Right and Left Side	2	
P3 [XG, XGH, XSD, XGF]	SPS853	Pad, Front Side	1	
P3 [X, XM, XE, XSW]	SPS1011	Pad, Front Side	1	
P4 [XG, XGH, XSD, SGF]	SPS1107	Pad, Bottom Side	1	O
P5 [X, XM] only	SPN5227	Carton Box	1	O
P5 [XG, XGH, XSD]	SPG1247	Carton Box	1	O
P5 [XGF]	SPG1249	Carton Box	1	O
P5 [XE, XSW]	SPG1251	Carton Box	1	O
P6	SQF1725	Printed Matter, Instructions Book	1	O
Notes: [X] is available in Asia, Latin America, Middle East and Africa only. [XM] is available in Panama and Mexico only. [XG] is available in European only. [XGH] is available in Holland only. [XSD] is available in Scandinavia only. [XSW] is available in Switzerland only. [XE] is available in England only. [XGF] is available in France only.				

■ ATTACHMENT OF FEET (INCLUDED)

This unit has an extra set of 4 feet which, if installed, lower the height by 8 mm, to 84 mm.

These feet are especially useful if other audio components in this series (models SH-9020, SE-9060, ST-9030 and SH-9010) are stacked one on top of another.

• Attachment

- ① Remove the feet already attached to the bottom of the unit.
- ② Attach the other set of feet (included) by using the screws (also included). Use the same holes as for the original feet.

* If the unit is used stacked on top of model SE-9060, note that the 2 feet toward the rear of the unit should be attached to the 2 holes indicated "A" in the illustration. (fig. 2)

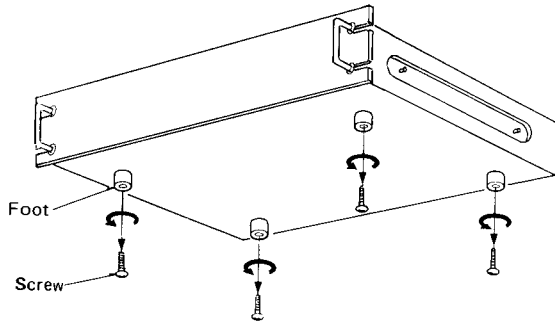

Fig. 1

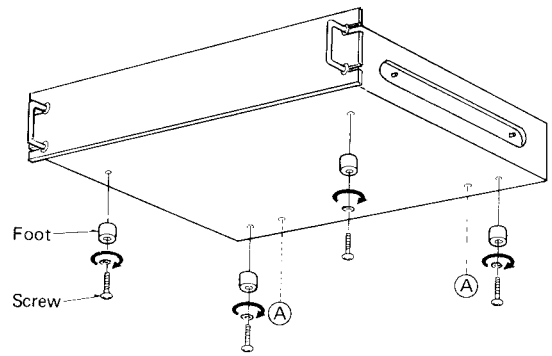
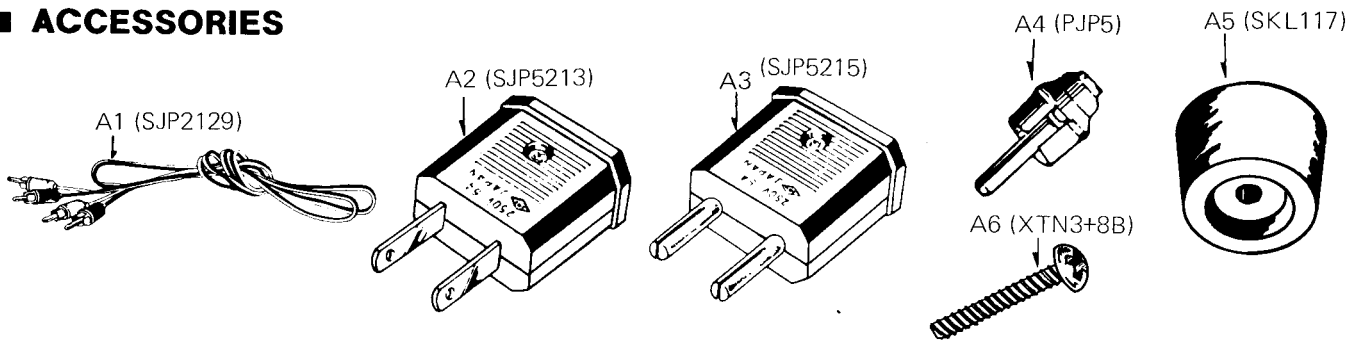
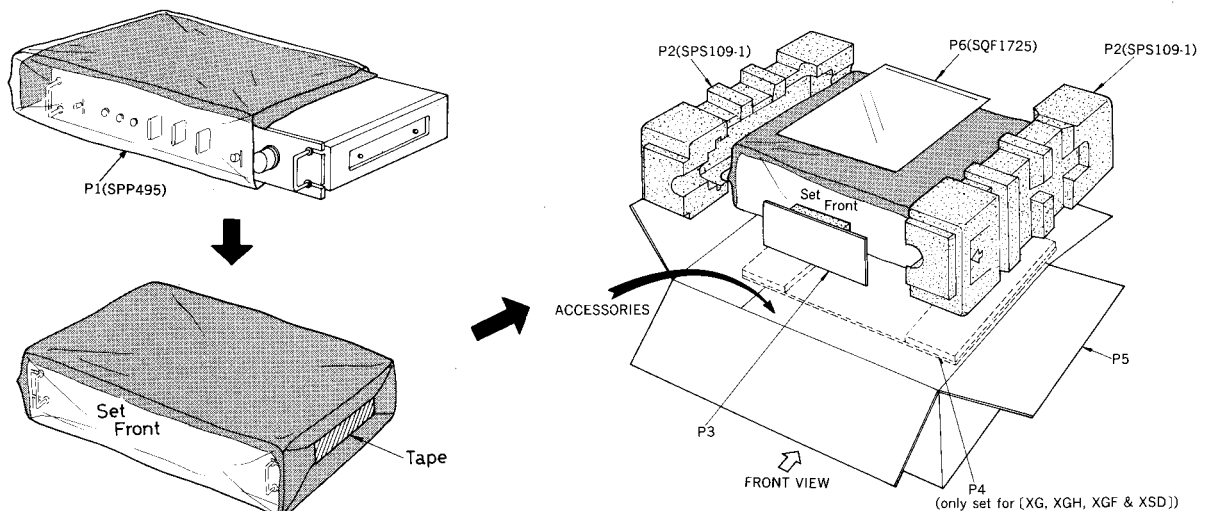

Fig. 2

■ ACCESSORIES



■ PACKINGS



Service Manual

Stereo Flat Preamp

SU-9070



Improvement of Abnormal Oscillation at MM Terminals

- Notes:
- * This service manual includes only the changes of the **SU-9070** service manual (ORDER NO. SD7708-1258).
 - * When servicing model **SU-9070**, this service manual and **SU-9070** (ORDER NO. SD7708-1258) service manuals should be used together.

REPLACEMENT PARTS LIST

Ref. No.	Old		New		
	Part No.	→ Part No.	Part Name & Description	Per Set	Remarks
R251,252	ERD25TJ180	ERD25TJ680	Carbon, 68Ω, 1/4W, ±5%	1	
C223,224	ECCD2H330K	ECCD2H680K	Ceramic, 68pF, 500V, ±10%	1	

SCHEMATIC DIAGRAM

Equalizer Circuitry

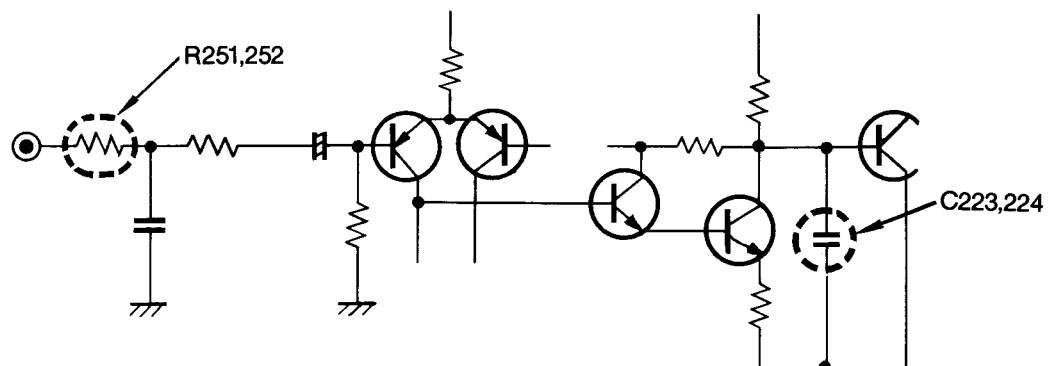

Parts Change Notice

Stereo Integrated Amplifier

SU-9200 (X),(XE),(XH),(FEE)

Re : Modification of Replacement Part

This is to advise you that part numbers of replacement parts have been changed on the following stereo models.

New part numbers (listed here in) are different from the replacement parts list of the stereo service manual.

Please revise the replacement parts list of the service manual or price list, and use new part numbers when placing replacement part orders.

Explanation of Notes :

Year		Month		Interchangeability		Reason of Change		New Suffix of set
5	1975	1	JAN.	A	(OLD) → (OLD)	1	To improve performance	New Suffix of set
6	1976	2	FEB.		(NEW) → (NEW)			
7	1977	3	MAR.	(OLD) → (OLD)	3	To meet approved specification		
8	1978	4	APR.	(NEW) → (NEW)			4	
.	.	5	MAY.	B	(OLD) → (OLD)	5		
.	.	6	JUN.		(NEW) → (NEW)		6	
.	.	7	JUL.	(OLD) → (OLD)	7	Correction		
.	.	8	AUG.	(NEW) → (NEW)			8	
		9	SEP.	C	(OLD) → (OLD)			
		J	OCT.		(NEW) → (NEW)			
		K	NOV.	(OLD) → (OLD)				
		L	DEC.	(NEW) → (NEW)				

Notes :

How to use the interchangeability chart

- The arrows indicate which sets the part can be used in.
- For parts classified A, both the old and the new parts can be used in both the old and the new sets.
- For parts classified B, old parts cannot be used in new sets.
- For parts classified A and B, gradually new parts only should be stocked.
- For parts classified C, the use of old parts should be discontinued, for reasons of performance, etc.
- For parts classified D, both new parts and old parts should be stocked because old and new are not interchangeable.

SU-9200(X), (XE), (XH), (FEE)

Stereo Department

Additional changes: see ↴

Refer to cover page

← Line	Description	Ref. No.	Service Manual	Notes →	Change - 1, (3)		Notes →	Change - 2, (4)		Line/ Page	↓ Line
			Part No.		Part No.	Price		Part No.	Price		
1	Transistor	TR101~104	2SA902-F	5KC1	2SA902S-F						1
2	Transistor	TR201~204	2SA902-F	5KC1	2SA902S-F						2
3	Transistor	TR509	2SC1509-Q	5KC1	2SA777-Q						3
4	Diode	D501	SVDAC08P-2R	68C8	RVD10DC2R						4
5	Diode	D502	SVDAC08P-2	68C8	RVD10DC2						5
6	AF Out put Relay	RLY1,2	SSEA14	5JC1	SSY11						6
7	Polyethylene Sheet	P2	SPHA6010	5KA2	SPP163						7
8											8
9											9
10											10
11											11
12											12
13											13
14											14
15											15
16											16
17											17
18											18
19											19
20											20
21											21
22											22
23											23
24											24
25											25

Parts Change Notice

Stereo Integrated Amplifier

SU-9600 (X),(XE),(XH),
(FEE),(XAL)

Re : Modification of Replacement Part

This is to advise you that part numbers of replacement parts have been changed on the following stereo models.

New part numbers (listed here in) are different from the replacement parts list of the stereo service manual.

Please revise the replacement parts list of the service manual or price list, and use new part numbers when placing replacement part orders.

Explanation of Notes :

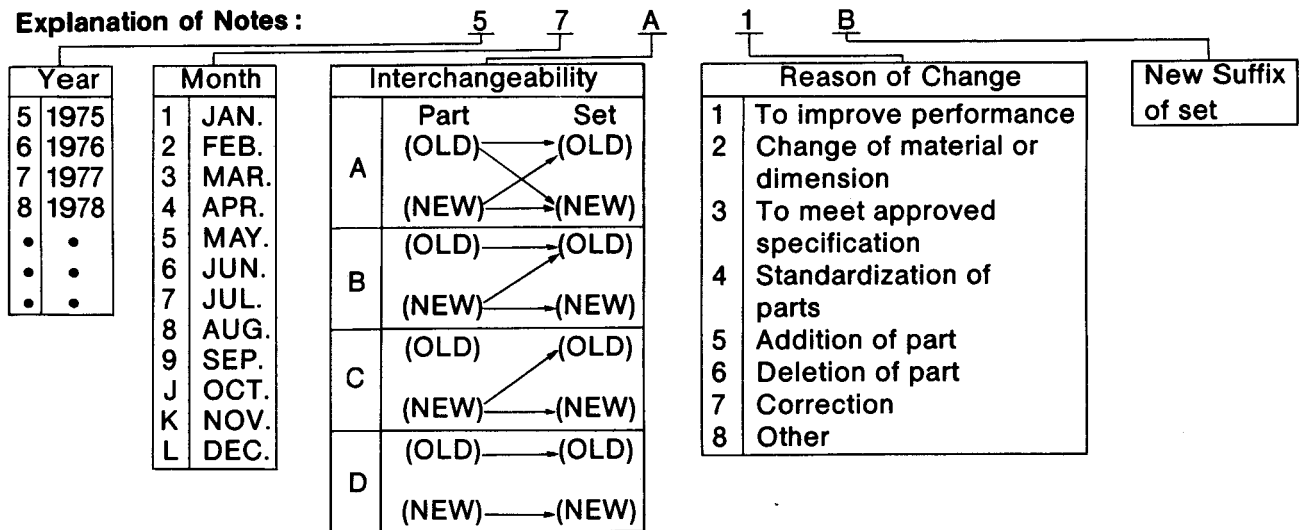

Notes :

How to use the interchangeability chart

- The arrows indicate which sets the part can be used in.
- For parts classified A, both the old and the new parts can be used in both the old and the new sets.
- For parts classified B, old parts cannot be used in new sets.
- For parts classified A and B, gradually new parts only should be stocked.
- For parts classified C, the use of old parts should be discontinued, for reasons of performance, etc.
- For parts classified D, both new parts and old parts should be stocked because old and new are not interchangeable.

SU-9600(X), (XE), (XH), (FEE), (XAL)

Stereo Department

Refer to cover page

Additional changes: see ↴

Line ↓	Description	Ref. No.	Service Manual	Notes →	Change - 1, (3)		Notes →	Change - 2, (4)		Line / Page	Line ↓
			Part No.		Part No.	Price		Part No.	Price		
1	Transistors (Except XAL)	TR101~108	2SA722STU	54C1	2SA902S-F						1
2	Transistors (Except XAL)	TR501~504	2SA722STU	54C1	2SA902S-F						2
3	Capacitor (Except XAL)	C6	Addition	66C1	ECEA10V47						3
4	Resistors (Except XAL)	R408~415	Addition	5JC1	ERD14TJ105		5LC1	ERC14GK825			4
5	Fuse	F1	XBA2F05NU5	61C7	XBA2F05NU100						5
6											6
7											7
8											8
9											9
10											10
11											11
12											12
13											13
14											14
15											15
16											16
17											17
18											18
19											19
20											20
21											21
22											22
23											23
24											24
25											25