

# Service Manual

## Amplifier SU-A200

Stereo Control Amplifier

Color

(K) . . . Black Type



Color	Areas
(K)	[M] . . . U.S.A.
(K)	[MC] . . . Canada
(K)	[E] . . . Scandinavia, Switzerland
(K)	[EF] . . . France
(K)	[Ei] . . . Italy
(K)	[EK] . . . United Kingdom
(K)	[EH] . . . Holland
(K)	[EGA] . . F.R. Germany
(K)	[EB] . . . Belgium
(K)	[XA] . . . Asia, Oceania, Latin America, Middle Near East and Africa
(K)	[XL] . . . Australia
(K)	[PA] . . . Far East PX
(K)	[PE] . . . European Military

## SPECIFICATIONS

(IHF'78)

### AUDIO SECTION

Total harmonic distortion (20Hz ~ 20kHz)	
PHONO MM (IHF'78)	0.001%
(2V output at Vol. max)	0.0009%
PHONO MC (IHF'78)	0.0015%
(2V output at Vol. max)	0.001%
TUNER, CD, AUX, AV1/TV, AV2	
DIGITAL TAPE 1, TAPE 2/VCR,	
TAPE 3/DA TAPE (IHF'78)	0.001%
(2V output at Vol. max)	0.0009%
DIRECT (IHF'78)	0.0009%
(2V output at Vol. max)	0.0008%
Input sensitivity and impedance	
PHONO MM	0.63mV/47kΩ
MC	25μV/220Ω
TUNER, CD, AUX, AV1/TV, AV2,	
DIGITAL TAPE 1, TAPE 2/VCR,	
TAPE 3/DA TAPE	36 mV/39kΩ
DIRECT	36 mV/15kΩ
PHONO maximum input voltage (1 kHz, RMS)	
MM	150mV
S/N	
PHONO MM	80 dB (90 dB, IHF' 66)
MC	77 dB (75 dB, IHF' 66)
TUNER, CD, AUX, AV1/TV, AV2,	
DIGITAL TAPE 1, TAPE 2/VCR,	
TAPE 3/DA TAPE	101 dB (109 dB, IHF' 66)
DIRECT	102 dB (110 dB, IHF' 66)

### FREQUENCY RESPONSE

PHONO MM	
20Hz ~ 20kHz, RIAA standard curve, ±0.2 dB	
20Hz ~ 100kHz, RIAA standard curve, ±0.5 dB	
TUNER, CD, AUX, AV1/TV, AV2, DIGITAL TAPE 1, TAPE 2/VCR, TAPE 3/DA TAPE	
20Hz ~ 20kHz, (+0, -0.1 dB)	
0.5Hz ~ 180kHz, (+0, -3.0 dB)	
20Hz ~ 20kHz, (+0, -0.1 dB)	
0.5Hz ~ 180kHz, (+0, -3.0 dB)	
DIRECT	
Subsonic filter	20Hz, -12 dB/oct.
High-cut filter	7kHz, -6 dB/oct.
Muting	-20 dB

Output voltage and impedance	
PRE OUT	rated 2V/4Ω max. 8V/4Ω
REC OUT	
TAPE 1, TAPE 2/VCR,	
TAPE 3/DA TAPE	150mV/600Ω

### VIDEO SECTION

Output voltage (at 1V input, unbalanced)	1±0.1 Vp-p
Maximum input voltage	1.5Vp-p
Input/output impedance	75 ohms unbalanced

# Technics

Matsushita Services Company  
50 Meadowland Parkway,  
Secaucus, New Jersey 07094

Panasonic Sales Company,  
Division of Matsushita Electric  
of Puerto Rico, Inc.  
Ave. 65 De Infanteria, KM 9.7  
Victoria Industrial Park  
Carolina, Puerto Rico 00630

Panasonic Hawaii, Inc.  
91-238, Kauhū St. Ewa Beach  
P.O. Box 774  
Honolulu, Hawaii 96808-0774

Matsushita Electric  
of Canada Limited  
5770 Ambler Drive, Mississauga,  
Ontario, L4W 2T3

Matsushita Electric Trading Co., Ltd.  
P.O. Box 288, Central Osaka Japan

Panasonic Tokyo Office  
Matsushita Electric Trading Co., Ltd.  
6th Floor, World Trade Center Bldg.,  
No. 4-1, Hamamatsu-cho 2-Chome,  
Minato-ku, Tokyo 105, Japan

# SU-A200

## ■ GENERAL

Power consumption	20W
Power supply	AC120V 60Hz
Dimensions (W x H x D)	430 x 125 x 360mm
Weight	9.2kg

### Note:

Total harmonic distortion is measured by the digital spectrum analyzer (H.P. 3045 system).

Specifications are subject to change without notice for further improvement.

Weight and dimensions shown are approximate.

## ■ CONTENTS

	Page		Page
SAFETY PRECAUTION .....	2	SWITCH OF OPERATION (IC201 ~ 203) .....	11
LOCATION OF CONTROLS .....	3	TRUTH TABLE OF IC (IC703, 704, 708, 709) .....	11
OPERATION .....	4	REPLACEMENT PARTS LIST (RESISTORS) .....	12
BEFORE REPAIR .....	5	PRINTED CIRCUIT BOARDS .....	13
DISASSEMBLY INSTRUCTIONS .....	5	WIRING CONNECTION DIAGRAM .....	17
FEATURES .....	7	SCHEMATIC DIAGRAM .....	20
FUNCTION OF TERMINAL (Analog Function Control IC701 : $\mu$ PD7506CT209) .....	8	CIRCUITS TO BE CHANGED AND THE AREAS .....	28
BLOCK DIAGRAM .....	9	REPLACEMENT PARTS LIST (CAPACITORS, ELECTRONIC PARTS, MECHANICAL PARTS) .....	30
BASIC OPERATION OF BGV SELECTOR CONTROL CIRCUIT (IC707) .....	11	EXPLODED VIEW .....	32

## ■ SAFETY PRECAUTION

(This "safety precaution" is applied only in U.S.A.)

1. Before servicing, unplug the power cord to prevent an electric shock.
2. When replacing parts, use only manufacturer's recommended components for safety.
3. Check the condition of the power cord. Replace if wear or damage is evident.
4. After servicing, be sure to restore the lead dress, insulation barriers, insulation papers, shields, etc.
5. Before returning the serviced equipment to the customer, be sure to make the following insulation resistance test to prevent the customer from being exposed to a shock hazard.

### ● INSULATION RESISTANCE TEST

1. Unplug the power cord and short the two prongs of the plug with a jumper wire.
2. Turn on the power switch.
3. Measure the resistance value with ohmmeter between the jumpered AC plug and each exposed metal cabinet part, such as screwheads antenna, control shafts, handle brackets, etc. Equipment with antenna terminals should read between  $3M\Omega$  and  $5.2M\Omega$  to all exposed parts. (Fig. A) Equipment without antenna terminals should read approximately infinity to all exposed parts. (Fig. B)

**Note:** Some exposed parts may be isolated from the chassis by design. These will read infinity.

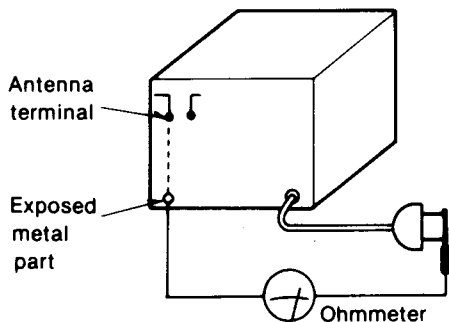

(Fig. A)

Resistance =  $3M\Omega - 5.2M\Omega$

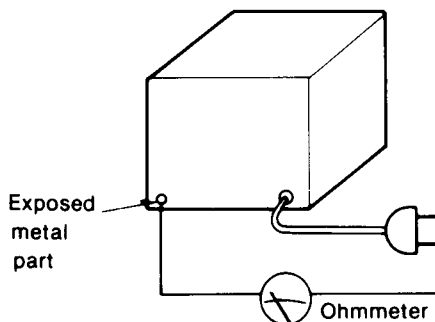

(Fig. B)

Resistance = Approx  $\infty$

4. If the measurement is outside the specified limits, there is a possibility of a shock hazard. The equipment should be repaired and rechecked before it is returned to the customer.

## LOCATION OF CONTROLS

### FRONT

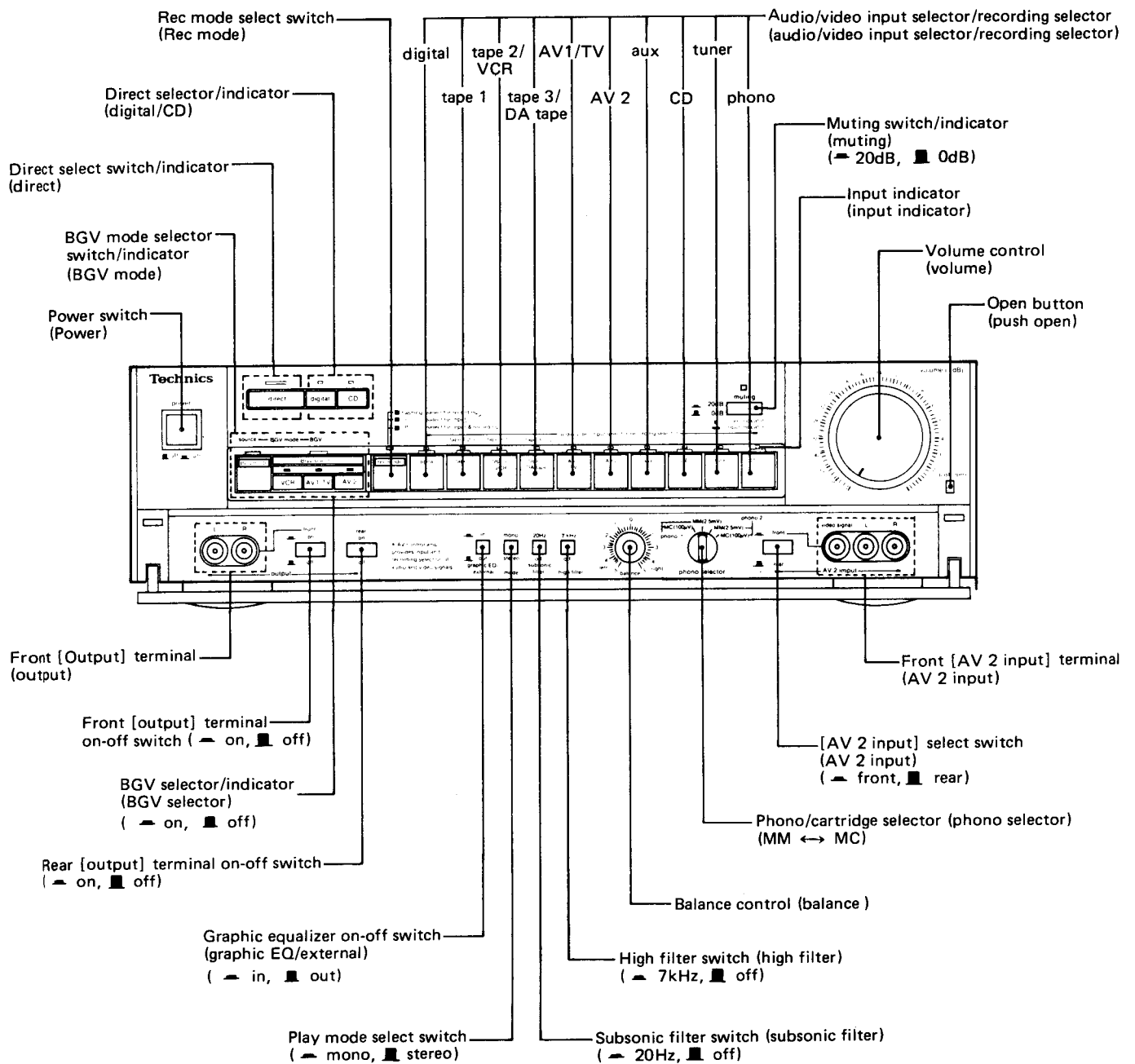

- The power supply for this unit varies depending upon the areas. Also, the parts used for power supply are different. So, refer to the circuit diagram and the replacement parts list.
  - \* 120V (60 Hz) for U.S.A. and Canada.
  - \* 110V/127V/220V/240V (50/60 Hz) for other areas.
  - \* Phono input capacitance is about 150pF.

# SU-A200

## • REAR

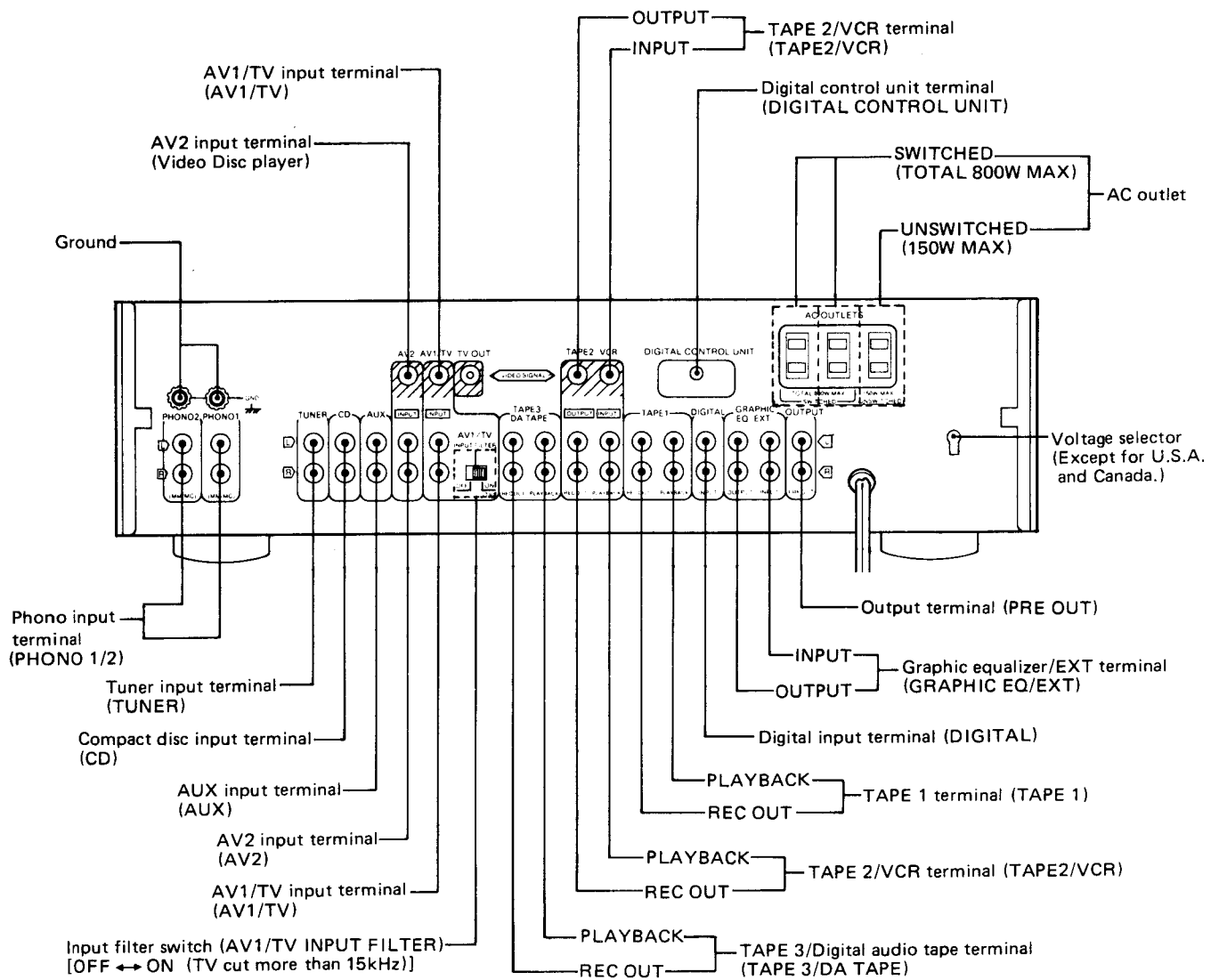

## ■ OPERATION

- To watch a video tape while listening to a compact disc.

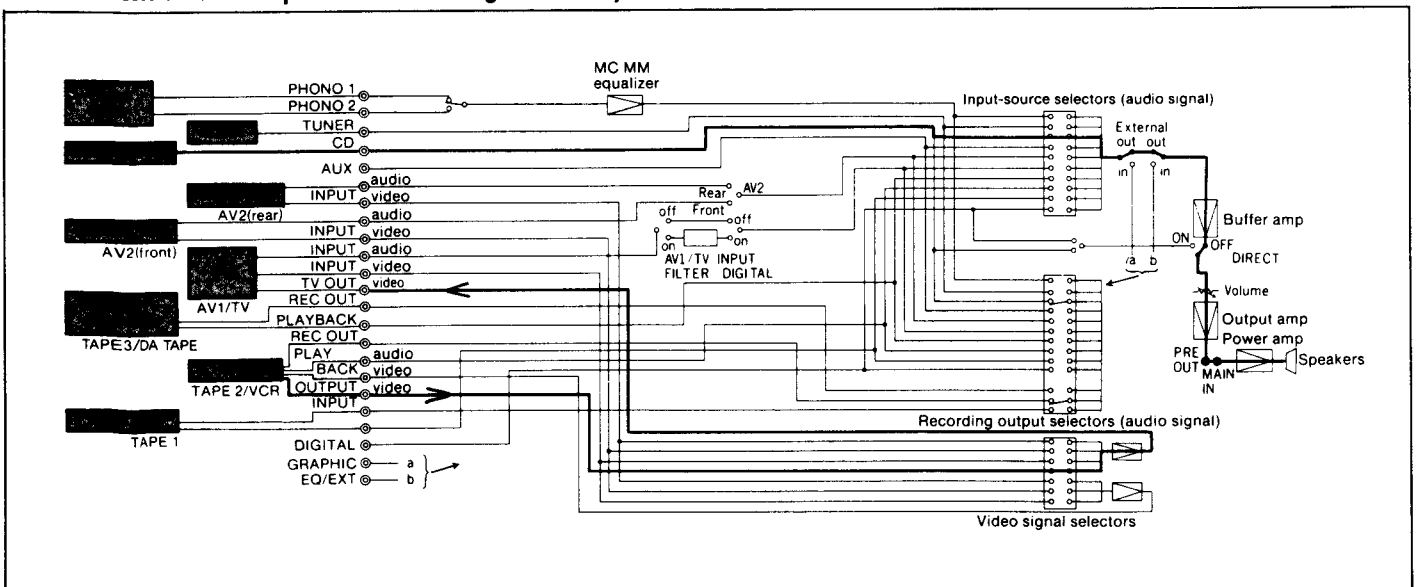



• To record a combination of compact disc sounds and video tape images.

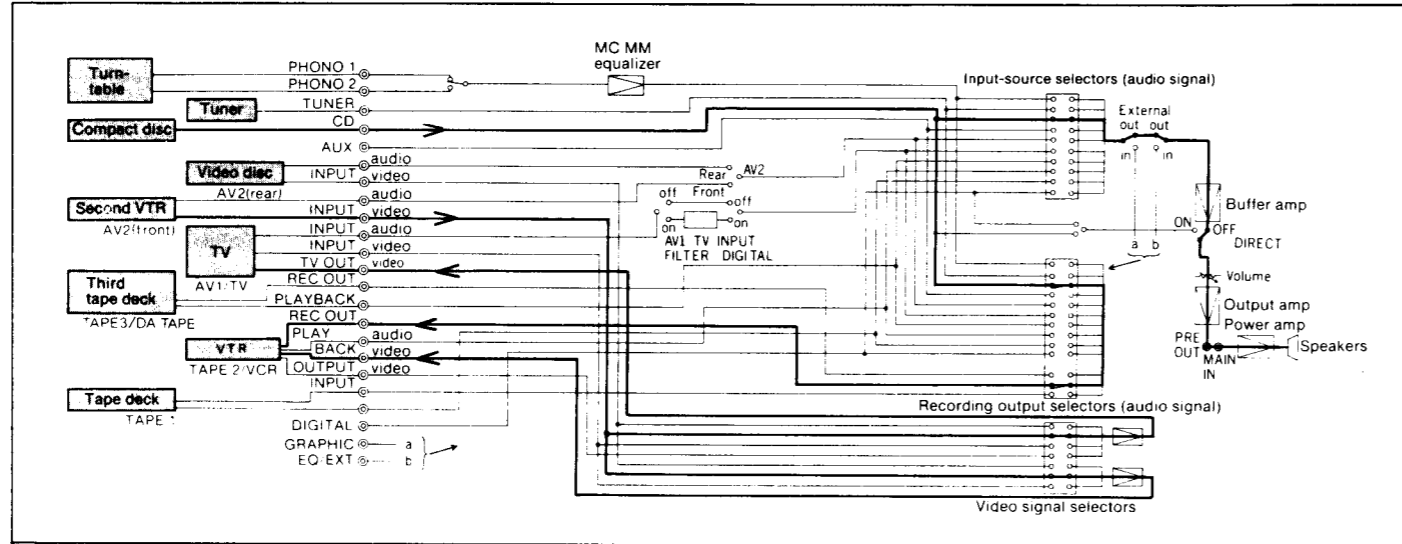

**BEFORE REPAIR**

- Turn off the power supply. Using a 10Ω, 5W resistor, short-circuit both ends of power supply capacitors (C501,502) and memory backup capacitors (C708, 709) of IC701 in order to discharge the voltage.
- Before turning the power supply on, after completion of repair, slowly apply the primary voltage by using a power supply voltage controller to make sure that the consumed current at 60Hz/50Hz in no-signal mode is shown with respect to supply voltage 110V/120V/127V/220V/240V.

Power supply voltage		AC 110V	AC120V	AC127V	AC220V	AC240V
Consumed current	50Hz	120 ~ 230mA	110 ~ 210mA	110 ~ 210mA	60 ~ 115mA	55 ~ 105mA
	60Hz	110 ~ 220mA	100 ~ 200mA	100 ~ 200mA	55 ~ 110mA	50 ~ 100mA

**DISASSEMBLY INSTRUCTIONS**

<p><b>Ref. No. 1</b></p> <p><b>How to remove the top board</b></p> <p><b>Procedure 1</b></p> <ul style="list-style-type: none"> <li>Remove the 7 screws ( ① ~ ⑦ ).</li> </ul>	<p><b>Ref. No. 2</b></p> <p><b>How to remove the bottom board</b></p> <p><b>Procedure 2</b></p> <ul style="list-style-type: none"> <li>Remove the 10 screws ( ① ~ ⑩ ).</li> </ul>
---	---

<p><b>Ref. No. 3</b></p> <p><b>How to remove the front panel</b></p> <p><b>Procedure 1 → 3</b></p> <ul style="list-style-type: none"> <li>Remove the 4 screws ( ① ~ ④ ).</li> <li>Turn it over as shown by arrow.</li> <li>Remove the 1 screw of muting indicator P.C.B. and the 6 screws of input/recording selector &amp; indicator P.C.B. ( ⑤ ~ ⑪ ).</li> </ul>	<p><b>Ref. No. 4</b></p> <p><b>How to remove the control panel door</b></p> <p><b>Procedure 1 → 3 → 4</b></p> <ul style="list-style-type: none"> <li>Remove the 4 screws ( ① ~ ④ ).</li> <li>Turn the control panel door hinge and gear counter-clockwise.</li> </ul> <p>Note) When assembling, apply grease (Part No. SZZ0L09) to movable parts.</p>
<p><b>Ref. No. 5</b></p> <p><b>How to remove the shield cover of video and power transformer P.C.B.</b></p> <p><b>Procedure 1 → 5</b></p> <ul style="list-style-type: none"> <li>Remove the 2 screws of video P.C.B. ( ① ~ ② ).</li> <li>Remove the 4 screws of power transformer P.C.B. ( ③ ~ ⑥ ).</li> </ul>	<p><b>Ref. No. 6</b></p> <p><b>How to remove the video and BNC TERMINAL P.C.B.</b> ([E] [EK] [EGA] [EF] [Ei] [EB] [EH] [XA] and [XL] areas only)</p> <p><b>Procedure 1 → 5 → 6</b></p> <ul style="list-style-type: none"> <li>Remove the 4 screws ( ① ~ ④ ) and 1 connector (J602) of the video P.C.B.</li> <li>Remove the nylon rivet ( ⑤ ~ ⑦ ) of BNC P.C.B. (Refer to Fig. A)</li> </ul>

**FEATURES**

Today is the digital age and the age of AV. So it's natural that control amplifiers are expected to meet the needs of these new times. "class AA", "active-servo power supply" and "compact disc/digital direct" ... functions which so thoroughly express the high quality and overwhelming D range of digital. Recording selector and electronic AV equipped with 10+2 inputs to perfectly meet the needs of AV. "Background video" selector for even more sophisticated control. The SU-A200 ... a true AV and digital control amplifier to meet today's newest needs and today's greatest challenges!

**class AA and active-servo power supply**

A new dimension of quality in control amplifiers is what class AA means. For this unit, this technology is used in the phono-equalizer and pre-out output amplifier. Beautiful, pure, class A sound, without being affected by severe fluctuations of the signal or by load conditions, is reproduced. In addition, this unit also includes the active-servo power supply, the perfect, stabilized power supply that operates in silence that even exceeds that of car batteries, often said to be the ideal power supply in that respect.

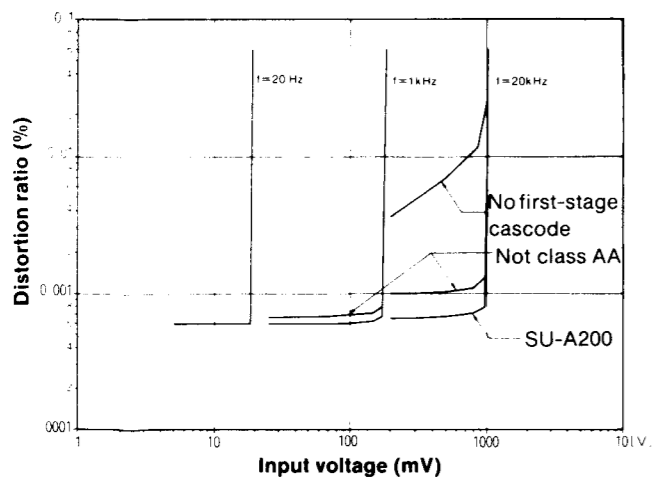
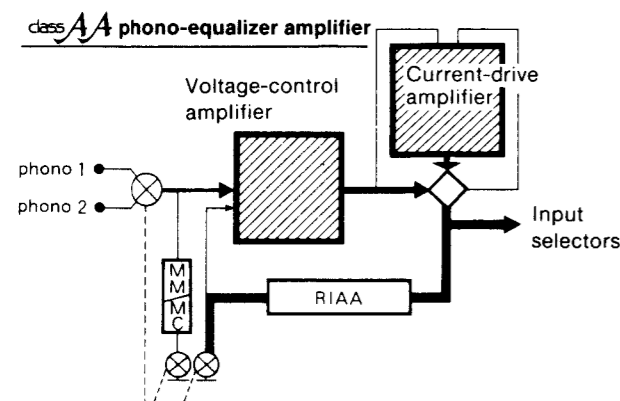

class AA phono-equalizer distortion characteristic curve

**Newly developed low-noise volume**

Thanks to the use of the newly developed PCL volume (Pure Conductive Low-noise variable resistor), when the volume is set to a reduced position for actual use, the output amplifier is set to low gain and, in addition, the noise level is greatly improved. Furthermore, the "direct through" function is equipped for compact discs and digital. The result is a pre-amplifier which reproduces digital silence as silence, without using selectors, filters or other circuits.

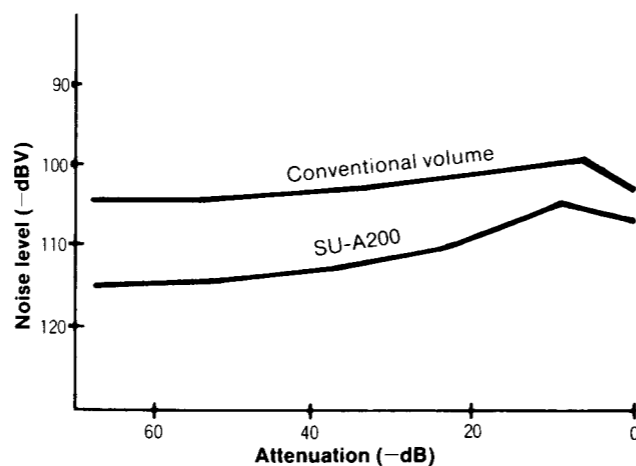
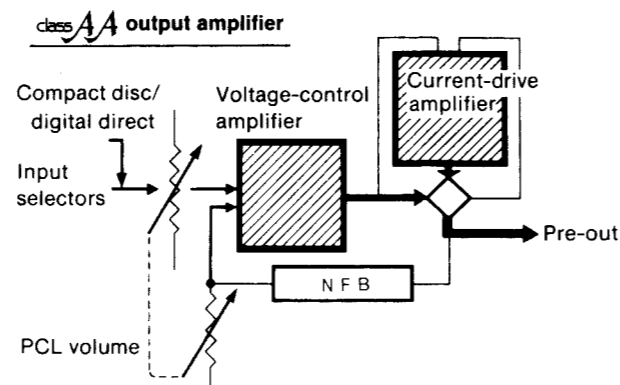

Noise comparison with conventional amplifier

**AV/recording selector and "background video" selectors**

Multiple inputs are an absolute must in the evolution of AV. This unit controls 10+2 systems of inputs and outputs. Moreover, there is simultaneous control of visual signals at three of those systems (AV1/TV, AV2 and VCR). In addition, the "background video" selectors can be used for individual control of sound and images. This is a multi-function amplifier which can also be used by AV fans for full control functions of an AV system.

**Luxuriously appointed as only the finest amplifier could be**

All input/output terminals and all relays gold-plated, 3 mm thick, heavyweight (3.0 kg) top panel ... and so many other luxurious features found in every circuit and every component of this control amplifier.

**FUNCTION OF TERMINAL (Analog Function Control IC701 : μPD7506CT209)**

Pin No.	Symbol	Input/Output	Active	Description of terminal
1	P43	—	—	Input side indicator 4-bit output. Input indicator drive signal to IC703 pin ⑫ . [Refer to ⑤ ]
2	x 2	—	—	Not used in this unit.
3	P03/x 1	—	—	Connected to ground.
4	CLK	Output	H	Clock output port for analog switch. Clock signal output to IC201 ~ 203 pins ⑩ during data transmission. [Refer to ⑤ ]
5	P21/PTOUT	Output	H	Indicator "rec selector" light up at "H". "rec selector" selection of input 4.3V selector 0V
6	DATA	Output	H	Data output for analog switch. Data signal output to IC203 pin ⑭ . [Refer to ⑤ ]
7	ST	Output	H	Strobe output port for analog switch. Strobe signal output to IC201 ~ 203 pins ⑪ during data transmission. [Refer to ⑤ ]
8	P60	Output	H	Rec side indicator 4-bit output. Rec indicator drive signal output to IC704 pins ⑫ ~ ⑮ . [Refer to ⑤ ]
9	P61			
10	P62			
11	P63			
12	CL1	Input	—	External clock oscillation. frequency (400kHz) input port.
13	CL2	—	—	Not used in this unit.
14	VDD	—	—	Power supply input terminal. (Apply 4.4V)
15	RESET	Input	H	Input terminal for reset signal.
16	P10	Input	H	Input terminal for key return signal from external key matrix.
17	P11			
18	P12			
19	P13			
20	P50	Output	H	Output terminal for key scan signal for external key matrix.
21	P51			
22	P52			
23	P53	Output	H	Muting signal output during input switch or Rec switch operation.
24	P00/INT	Input	—	Mode shifting port.
25	P40	Output	H	Input side indicator 4-bit output. Input indicator drive signal to IC703 pins ⑬ ~ ⑮ . [Refer to ⑤ ]
26	P41			
27	P42			
28	VSS	—	—	Ground terminal.

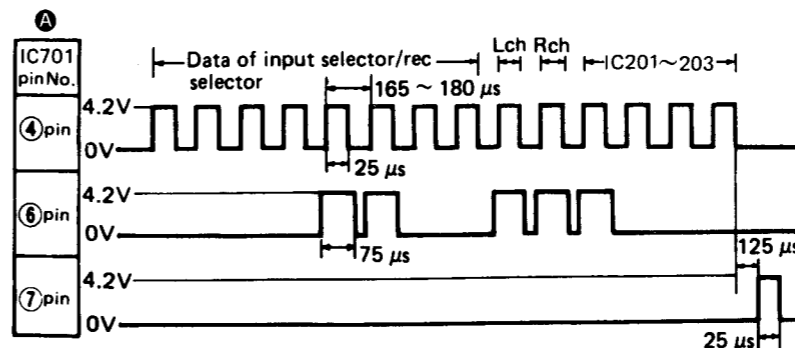

Pin No. of IC 701	⑧	⑨	⑩	⑪
Input selector	25	26	27	①
PHONO	L	L	L	L
TUNER	H	L	L	L
AUX	L	H	L	L
CD	H	H	L	L
AV2	L	L	H	L
AV1/TV	H	L	H	L
DIGITAL	L	H	H	L
TAPE 3	H	H	H	L
TAPE 2/VCR	L	L	L	H
TAPE 1	H	L	L	H

# BLOCK DIAGRAM

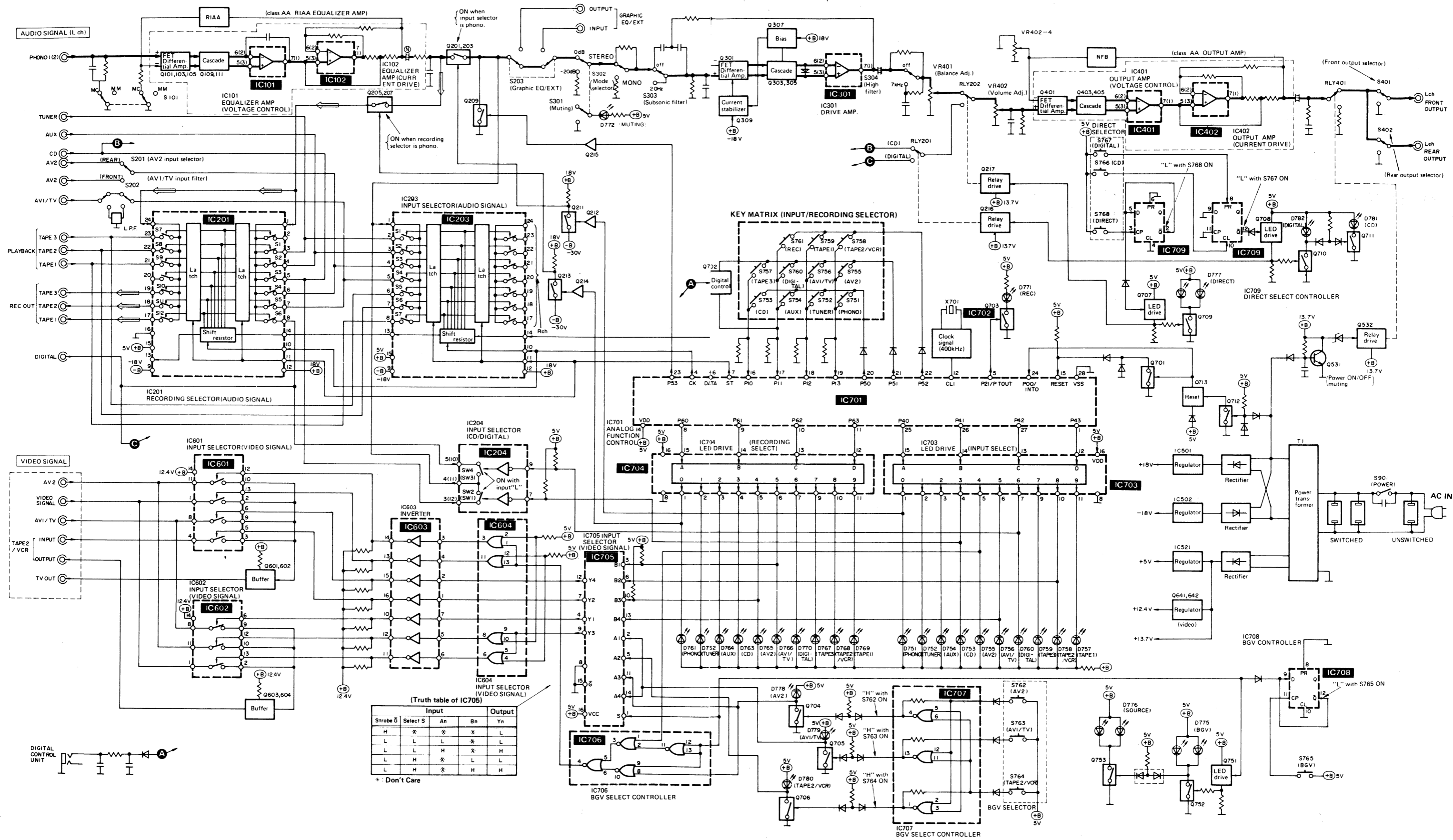

### BASIC OPERATION OF BGV SELECTOR CONTROL CIRCUIT (IC707)

The input selector control circuit is a flip-flop circuit using NOR gate. The output of NOR gate goes "L" when even one of the input terminals is at "H". For example, with tact switch S762 depressed as shown below, the level of signal applied to input terminals of I2 and I3 is "H", and the output goes "L". The outputs of I2 and I3 are applied to input terminals of I1, causing only the level of I1 to go "H". With S763 depressed, "H" is applied to input terminals of I1 and I3, causing the output of I1 to change from "H" to "L". The output is then applied to I2 and I3, changing the output of I2 to "H" and that of I3 to "L". The circuit of this unit is of 3-stage configuration as shown in the block diagram, and operates as explained above.

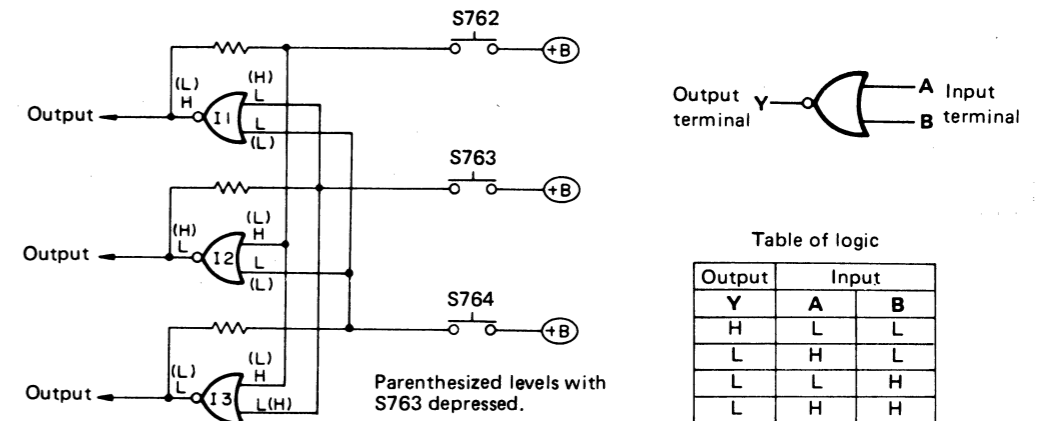

### SWITCH OF OPERATION (IC201 ~ 203)

• IC201, 202

Mode	SW	(off : -)											
		S <sub>1</sub>	S <sub>2</sub>	S <sub>3</sub>	S <sub>4</sub>	S <sub>5</sub>	S <sub>6</sub>	S <sub>7</sub>	S <sub>8</sub>	S <sub>9</sub>	S <sub>10</sub>	S <sub>11</sub>	S <sub>12</sub>
Mode selection by recording selector with phono signal playback.	phono	-	-	-	-	-	-	-	-	-	ON	ON	ON
	tuner	ON	-	-	-	-	-	-	-	-	ON	ON	ON
Mode selection by input selector.	aux	-	ON	-	-	-	-	-	-	-	ON	ON	ON
	AV 2	-	-	ON	-	-	-	-	-	-	ON	ON	ON
	AV 1/TV	-	-	-	ON	-	-	-	-	-	ON	ON	ON
	tape 3 (tape 3-1)	-	-	-	-	ON	-	-	-	-	-	ON	-
	tape 2 (tape 2-1)	-	-	-	-	-	ON	-	-	-	-	-	ON
	tape 1 (tape 1-2)	-	-	-	-	-	-	ON	-	-	-	ON	-
	digital	-	-	-	-	-	-	-	ON	-	-	ON	ON

• IC203

Mode	SW	(off : -)						
		S <sub>1</sub>	S <sub>2</sub>	S <sub>3</sub>	S <sub>4</sub>	S <sub>5</sub>	S <sub>6</sub>	S <sub>7</sub>
Mode selection by recording selector with phono signal playback.	phono	-	-	-	-	-	-	-
	tuner	ON	-	-	-	-	-	-
Mode selection by input selector.	aux	-	ON	-	-	-	-	-
	AV 2	-	-	ON	-	-	-	-
	AV 1/TV	-	-	-	ON	-	-	-
	tape 3	-	-	-	-	ON	-	-
	tape 2	-	-	-	-	-	ON	-
tape 1	-	-	-	-	-	-	ON	

### TRUTH TABLE OF IC (IC703, 704, 708, 709)

• IC703, 704

Mode	Input				Output									
	D	C	B	A	0	1	2	3	4	5	6	7	8	9
phono	L	L	L	L	L	H	H	H	H	H	H	H	H	H
tuner	L	L	L	H	H	L	H	H	H	H	H	H	H	H
aux	L	L	H	L	H	H	L	H	H	H	H	H	H	H
CD	L	L	H	H	H	H	L	H	H	H	H	H	H	H
AV 2	L	H	L	L	H	H	H	L	H	H	H	H	H	H
AV 1/TV	L	H	L	H	H	H	H	H	L	H	H	H	H	H
digital	L	H	H	L	H	H	H	H	H	L	H	H	H	H
tape 3	L	H	H	H	H	H	H	H	H	H	L	H	H	H
tape 2/VCR	H	L	L	L	H	H	H	H	H	H	H	L	H	H
tape 1	H	L	L	H	H	H	H	H	H	H	H	H	L	H

• IC708, 709

Input	Output				
	Q <sub>n+1</sub>	Q̄ <sub>n+1</sub>			
CL	PR	D	CP <sub>A</sub>	Q <sub>n+1</sub>	Q̄ <sub>n+1</sub>
L	H	*	*	H	L
H	L	*	*	L	H
L	L	L	↕	L	H
L	L	H	↕	H	L
L	L	*	↕	Q <sub>n</sub>	Q̄ <sub>n</sub>

\* : Don't care  
 Δ : Level change

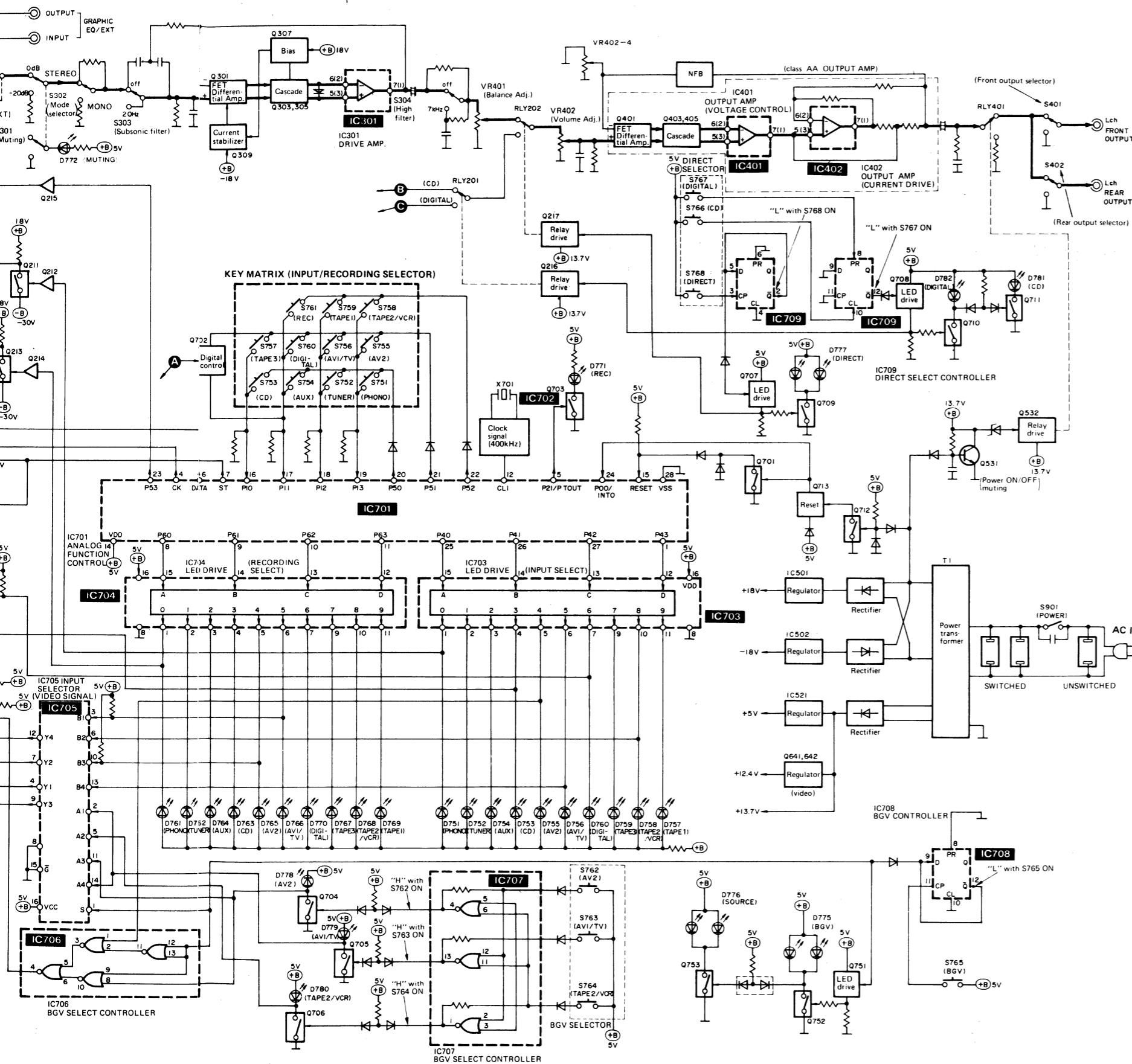



REPLACEMENT PARTS LIST

- Notes: 1. Part numbers are indicated on most mechanical parts. Please use this part number for parts orders.
2. Important safety notice: Components identified by  $\Delta$  mark have special characteristics important for safety. When replacing any of these components use only manufacturer's specified parts.
3. Bracketed indications in Ref. No. columns specify the area. Parts without these indications can be used for all areas.

4. The "S" mark is service standard parts and may differ from production parts.
5. The unit of resistance is OHM ( $\Omega$ ).  
K = 1000 $\Omega$ , M = 1000K $\Omega$
6. The unit of capacitance is MICROFARAD ( $\mu$ F).  
P = 10<sup>-6</sup>  $\mu$ F
7. The parenthesized numbers in the column of description stand for the quantity per set.

Resistor Type	Wattage	Tolerance
ERD : Carbon	10 : 1/8W	J : $\pm$ 5%
ERG : Metal Oxide	25 : 1/4W	G : $\pm$ 2%
ERC : Solid	2F : 1/4W	K : $\pm$ 10%
	S2 : 1/4W	
	S1 : 1/2W	
	12 : 1/2W	

Capacitor Type	Voltage		Tolerance
	ECEA Type	Other	
ECEA...N : Non-polar Electrolytic	2R3 : 2.3V	05 : 50V DC	C : $\pm$ 0.25pF
ECEA : Electrolytic	DC	1H : 50V DC	J : $\pm$ 5%
ECCD : Ceramic	0J : 6.3V	1 : 125V DC	K : $\pm$ 10%
ECKD : Ceramic	1C : 16V	2H : 500V DC	Z : +80%, -20%
ECQM : Polyester	1E : 25V	KC : 400V AC	M : $\pm$ 20%
ECQV : Polyester	1V : 35V		
ECQP : Polypropylene	1H : 50V		
EECW : Liquid electrolyte double layer capacitor	50 : 50V		
	25 : 25V		
ECKF : Ceramic	2A : 100V		

RESISTORS

Ref. No.	Part No.	Value	Ref. No.	Part No.	Value	Ref. No.	Part No.	Value
R101, 102	ERDS2TJ222	2.2K	R271, 272	ERDS2TJ471	470	R611	ERDS2TJ121	120
[EGA] only			[EGA] only			R612	ERDS2TJ151	150
R101, 102	ERDS2TJ102	1K	R273, 274	ERDS2TJ471	470	R613	ERDS2TJ272	2.7K
[other]			[EGA] only			R614	ERDS2TJ680	68
R103, 104	ERDS2TJ222	2.2K	R275, 276	ERDS2TJ471	470	R615	ERDS2TJ330	33
[EGA] only			[EGA] only			R616, 617	ERDS2TJ680	68
R103, 104	ERDS2TJ102	1K	R301, 302	ERDS2TJ333	33K	R618	ERDS2TJ272	2.7K
[other]			R303, 304	ERDS2TJ392	3.9K	R619	ERDS2TJ121	120
R105, 106	ERDS2TJ2R2	2.2	R305, 306	ERDS2TJ472	4.7K	R620	ERDS2TJ151	150
R107, 108	ERDS2TJ473	47K	R307, 308	ERDS2TJ124	120K	R621	ERDS2TJ222	2.2K
R109, 110	ERDS2TJ221	220	R309, 310	ERDS2TJ224	220K	R622	ERDS2TJ122	1.2K
R111, 112	ERDS2TJ102	1K	R311, 312	ERDS2TJ473	47K	R623, 624	ERDS2TJ272	2.7K
R113, 114	ERDS2TJ470	47	R313, 314	ERDS2TJ181	180	R625, 626	ERDS2TJ272	2.7K
R115, 116	EROS2TKG1001	1K	R315, 316	ERDS2TJ332	3.3K	R627, 628	ERDS2TJ103	10K
R117, 118	EROS2TKG1001	1K	R317, 318	ERDS2TJ332	3.3K	R651	ERDS2TJ472	4.7K
R119, 120	ERDS2TJ333	33K	R319, 320	ERDS2TJ103	10K	R701	ERDS2TJ823	82K
R121, 122	EROS2TKG1001	1K	R321, 322	ERDS2TJ154	150K	R703	ERDS2TJ103	10K
R123, 124	EROS2TKF82R0	82	R323, 324	ERDS2TJ102	1K	R704	ERDS2TJ472	4.7K
R125, 126	ERDS2TJ3R3	3.3	R325, 326	ERDS2TJ103	10K	R705	ERDS2TJ473	47K
R127, 128	ERDS2TJ221	220	R327, 328	ERDS2TJ471	470	R706, 707	ERDS2TJ104	100K
R129, 130	EROS2TKF4702	47K	R329, 330	ERDS2TJ824	820K	R708, 709	ERDS2TJ104	100K
R131, 132	EROS2TKF3901	3.9K	R331	ERDS2TJ824	820K	R710	ERDS2TJ681	680
R133, 134	ERDS2TJ334	330K	R401, 402	ERDS2TJ224	220K	R711, 712	ERDS2TJ473	47K
R135, 136	ERDS2TJ561	560	R403, 404	ERDS2TJ101	100	R713, 714	ERDS2TJ473	47K
R137, 138	EROS2TKG1001	1K	R405, 406	ERDS2TJ222	2.2K	R715	ERDS2TJ473	47K
R139, 140	EROS2TKG3301	3.3K	R407, 408	ERDS2TJ222	2.2K	R716, 717	ERDS2TJ103	10K
R141, 142	EROS2TKG10R0	10	R409, 410	ERDS2TJ473	47K	R718	ERDS2TJ103	10K
R143, 144	EROS2TKG33R0	33	R411, 412	ERDS2TJ222	2.2K	R719, 720	ERDS2TJ272	2.7K
R145, 146	$\Delta$ ERD25FJ221	220	R413, 414	ERDS2TJ333	33K	R721	ERDS2TJ272	2.7K
R201, 202	ERDS2TJ102	1K	R415, 416	ERDS2TJ332	3.3K	R722	ERDS2TJ103	10K
R203, 204	ERDS2TJ332	3.3K	R417, 418	ERDS2TJ221	220	R724, 725	ERDS2TJ103	10K
R205	ERDS2TJ103	10K	R419, 420	EROS2TKG10R0	10	R726	ERDS2TJ272	2.7K
R206	ERDS2TJ473	47K	R421, 422	EROS2TKG33R0	33	R727, 728	ERDS2TJ103	10K
R207	ERDS2TJ103	10K	R423, 424	EROS2TKG1001	1K	R729	ERDS2TJ103	10K
R208	ERDS2TJ334	330K	R425, 426	EROS2TKG3301	3.3K	R730, 731	ERDS2TJ272	2.7K
R209	ERDS2TJ472	4.7K	R427, 428	ERDS2TJ823	82K	R733	ERDS2TJ223	22K
R210	ERDS2TJ473	4.7K	R429, 430	ERDS2TJ560	56	R734	ERDS2TJ333	33K
R211, 212	ERDS2TJ272	2.7K	R431, 432	ERDS2TJ560	56	R735, 736	ERDS2TJ103	10K
R213, 214	ERDS2TJ121	120	R433, 434	ERDS2TJ101	100	R751, 752	ERDS2TJ151	150
R215, 216	ERDS2TJ104	100K	R435, 436	ERDS2TJ272	2.7K	R753, 754	ERDS2TJ151	150
R217, 218	ERDS2TJ104	100K	R501	ERDS2TJ102	1K	R755, 756	ERDS2TJ151	150
R251, 252	ERDS2TJ222	2.2K	R502	ERDS2TJ333	33K	R757, 758	ERDS2TJ151	150
[EGA] only			R503	ERDS2TJ102	1K	R759, 760	ERDS2TJ151	150
R253, 254	ERDS2TJ222	2.2K	R504	ERDS2TJ333	33K	R761, 762	ERDS2TJ103	10K
[EGA] only			R521	ERG5AJ150	15	R763	ERDS2TJ103	10K
R255, 256	ERDS2TJ471	470	R531	ERDS2TJ682	6.8K	R764	ERDS2TJ103	10K
[EGA] only			R532	ERDS2TJ104	100K	R765, 766	ERDS2TJ272	2.7K
R257, 258	ERDS2TJ471	470	R533	ERDS2TJ472	4.7K	R767, 768	ERDS2TJ151	150
[EGA] only			R534	ERDS2TJ153	15K	R769	ERDS2TJ151	150
R259, 260	ERDS2TJ471	470	R535	ERDS2TJ224	220K	R801, 802	ERDS2TJ473	47K
[EGA] only			R537	ERDS2TJ274	270K	R803, 804	ERDS2TJ473	47K
R261, 262	ERDS2TJ471	470	R538	ERDS2TJ121	120	R805, 806	ERDS2TJ473	47K
[EGA] only			R541	ERD25FJ221	220	R807, 808	ERDS2TJ473	47K
R263, 264	ERDS2TJ471	470	R543, 544	ERDS2TJ100	10	R809, 810	ERDS2TJ473	47K
[EGA] only			R601, 602	ERDS2TJ820	82	R811, 812	ERDS2TJ473	47K
R265, 266	ERDS2TJ471	470	R603, 604	ERDS2TJ820	82	R813, 814	ERDS2TJ473	47K
[EGA] only			R605	ERDS2TJ272	2.7K	R815, 816	ERDS2TJ473	47K
R267, 268	ERDS2TJ471	470	R606	ERDS2TJ680	68	R817, 818	ERDS2TJ473	47K
[EGA] only			R607	ERDS2TJ330	33	R819, 820	ERDS2TJ473	47K
R269, 270	ERDS2TJ471	470	R608, 609	ERDS2TJ680	68	R821, 822	ERDS2TJ473	47K
[EGA] only			R610	ERDS2TJ272	2.7K			

PRINTED CIRCUIT BOARDS

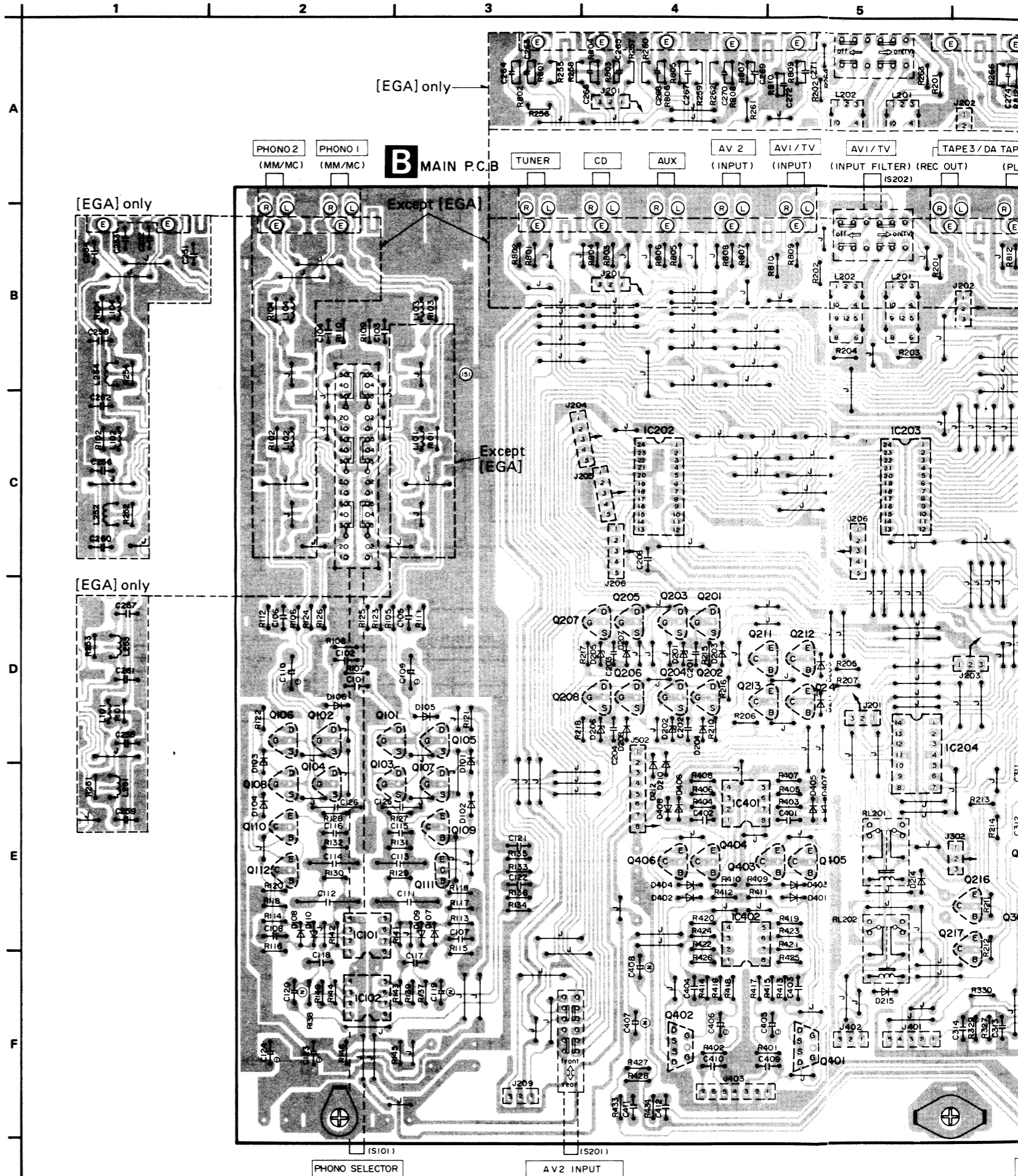



PRINTED CIRCUIT BOARDS

may differ  
 μF).  
 of descrip-

Tolerance

± 0.25pF
± 5%
+80% -20%
±20%

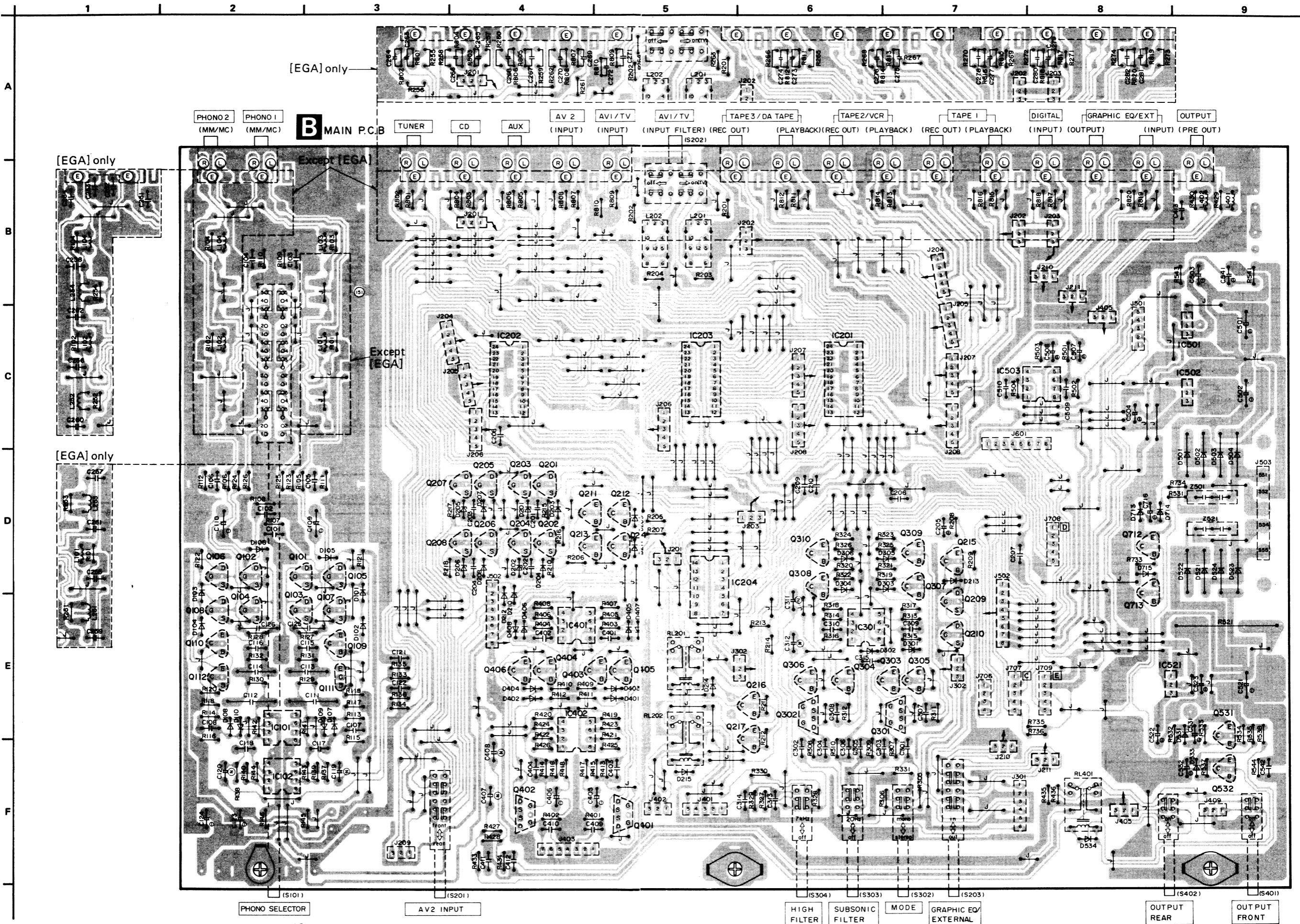



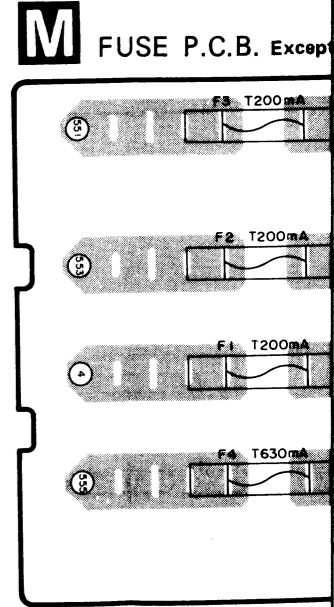
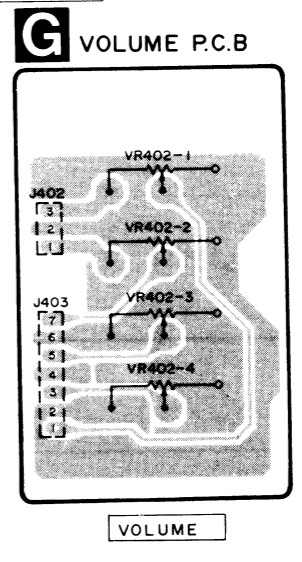
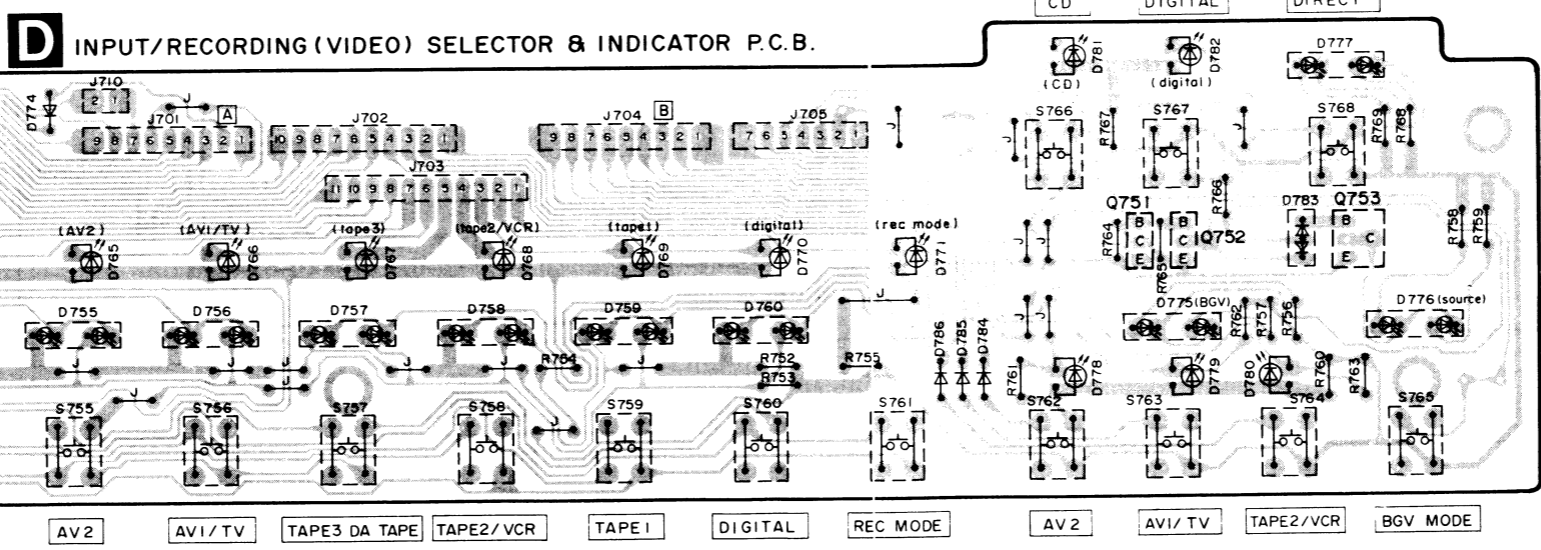
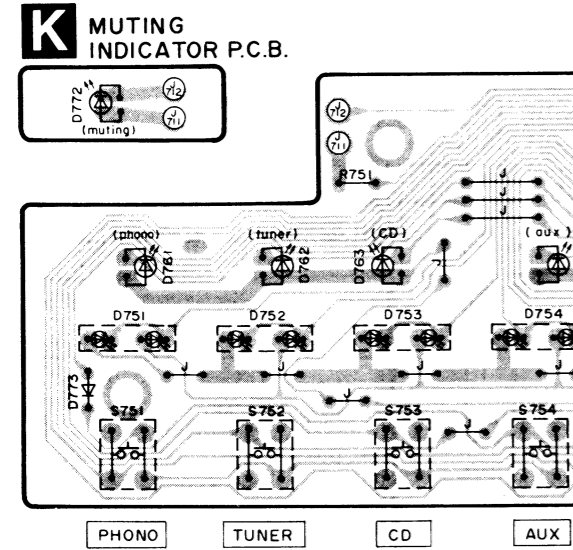
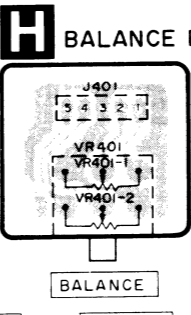
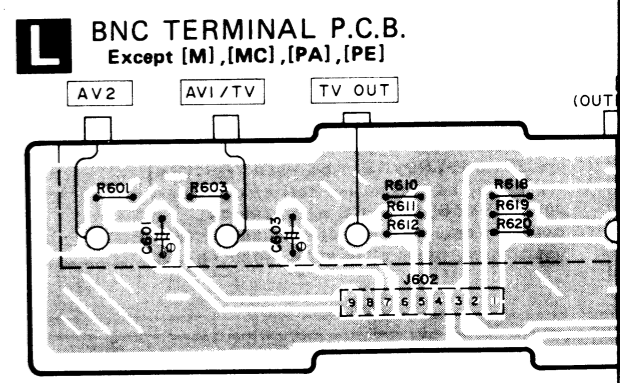
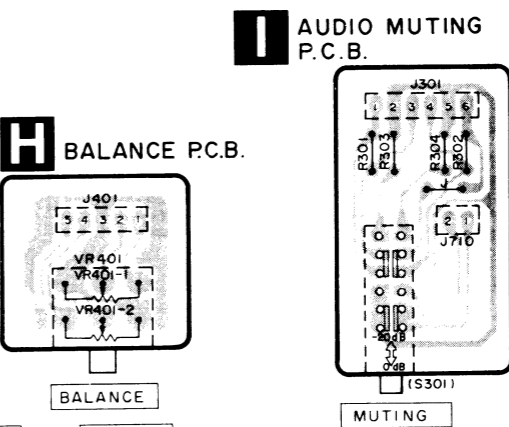
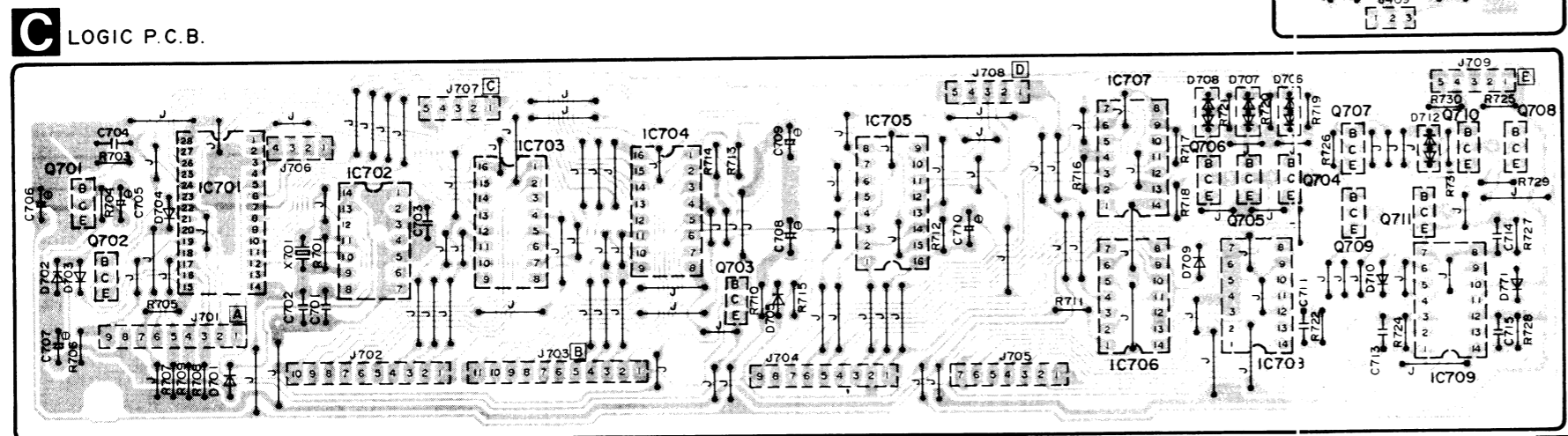
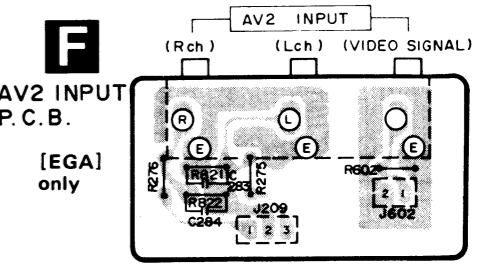
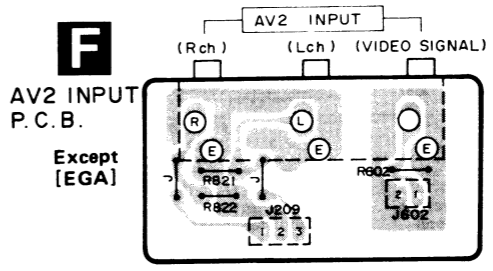
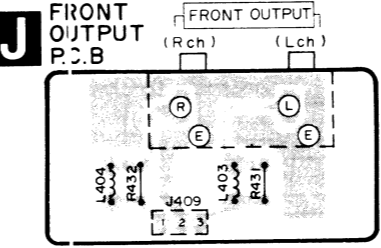
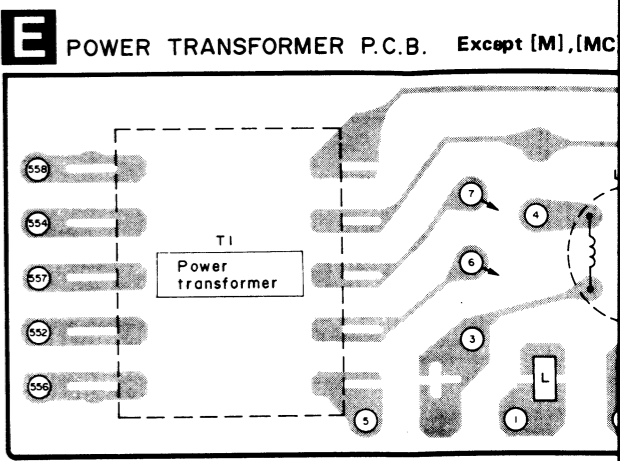
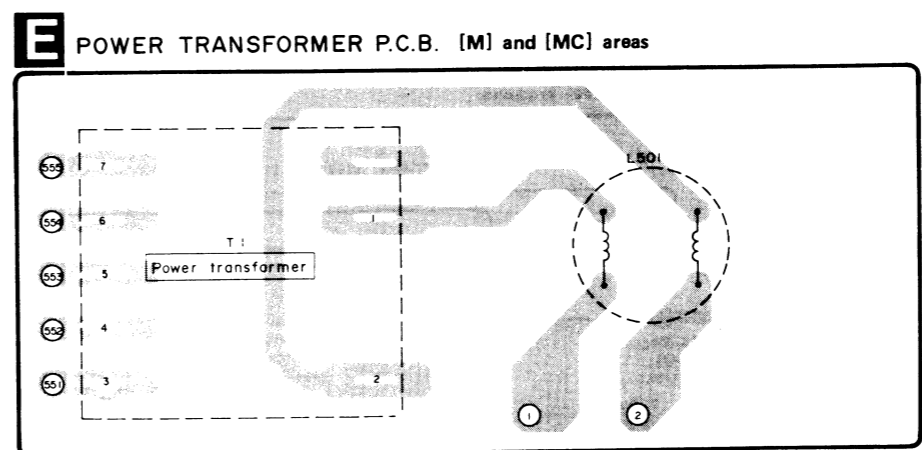
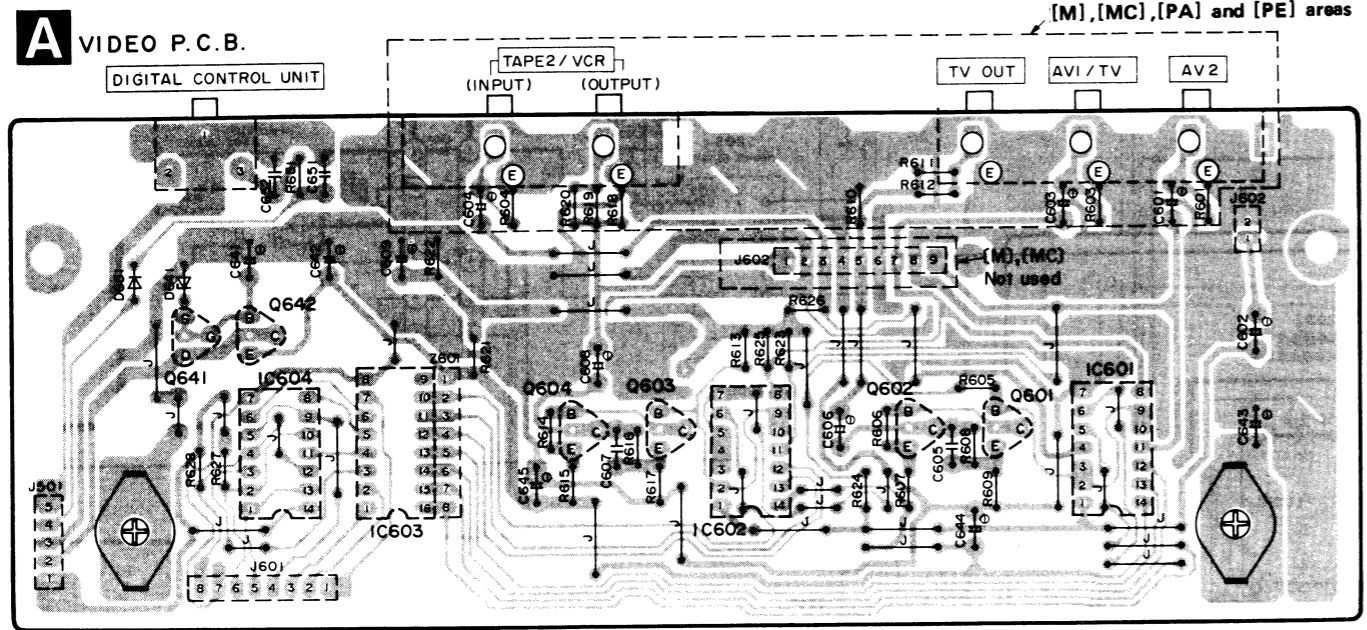

WIRING CONNECTION DIAGRAM

17 18 19 20

**E** POWER TRANSFORMER P.C.B. Except [M],[MC]

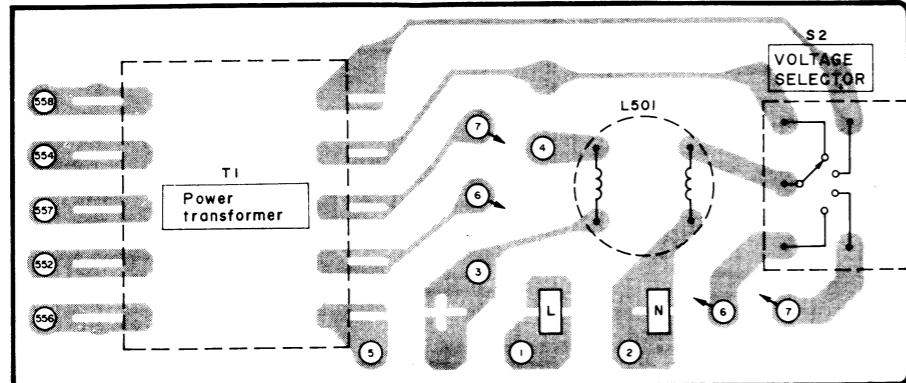

**F** AV2 INPUT P.C.B. [EGA] only

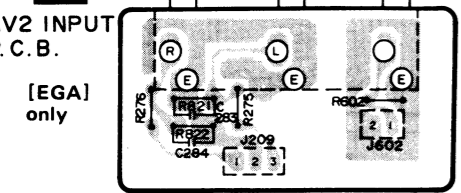

**L** BNC TERMINAL P.C.B. Except [M],[MC],[PA],[PE]

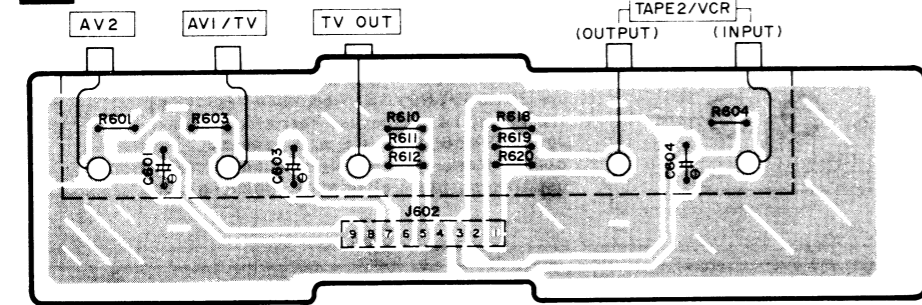

**AUDIO MUTING P.C.B.**

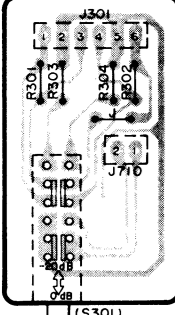

**G** VOLUME P.C.B.

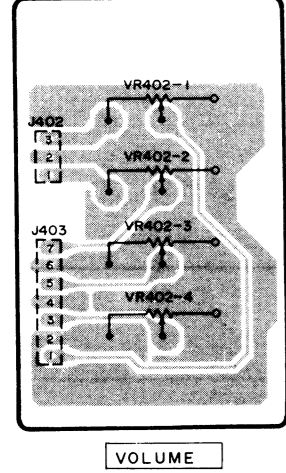

**M** FUSE P.C.B. Except [M],[MC]

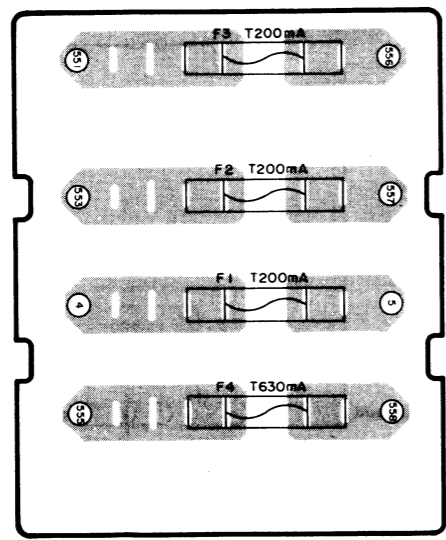

[M] and [MC] areas

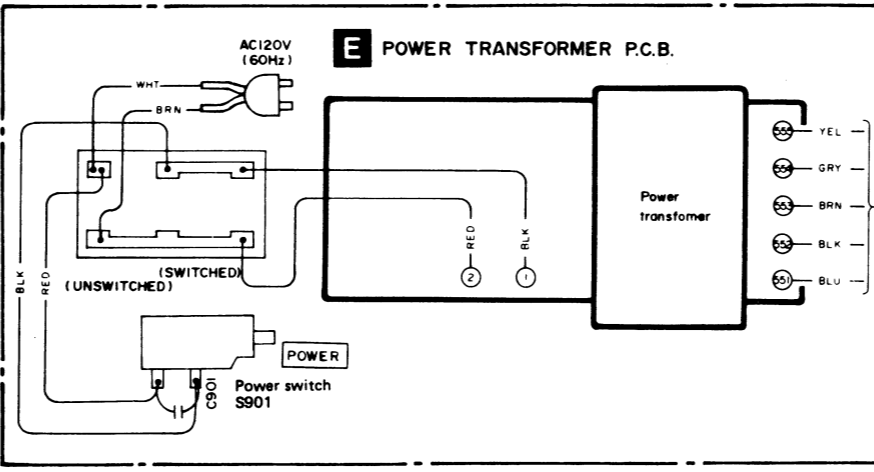

[E],[EGA],[EK],[EF],[Ei],[EH],[EB] and [XL] areas

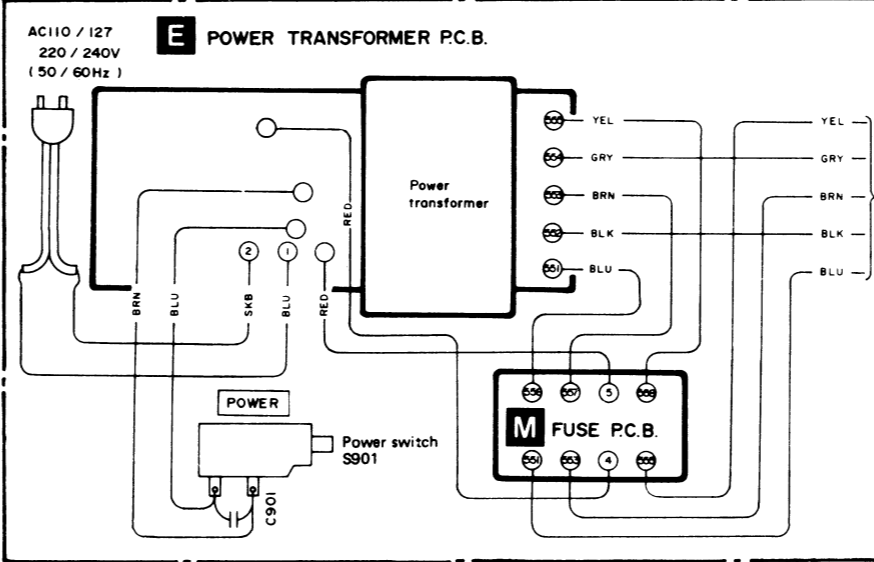

[XA],[PA] and [PE] areas

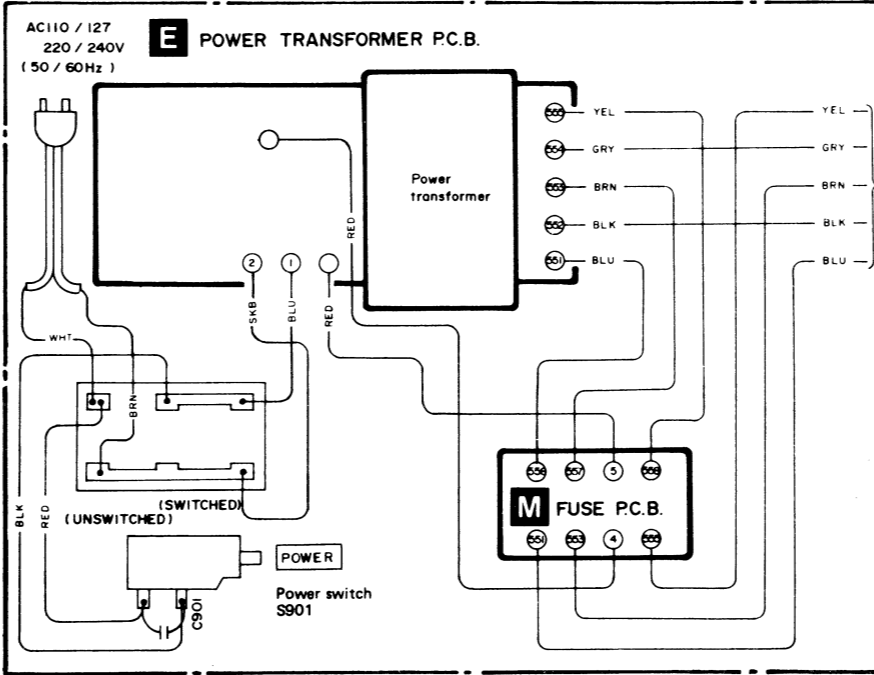

- Note**
- WHT : White
  - RED : Red
  - GRY : Grey
  - BRN : Brown
  - BLK : Black
  - SLD : Shield Line
  - BLU : Blue
  - YEL : Yellow
  - SKB : Sky Blue

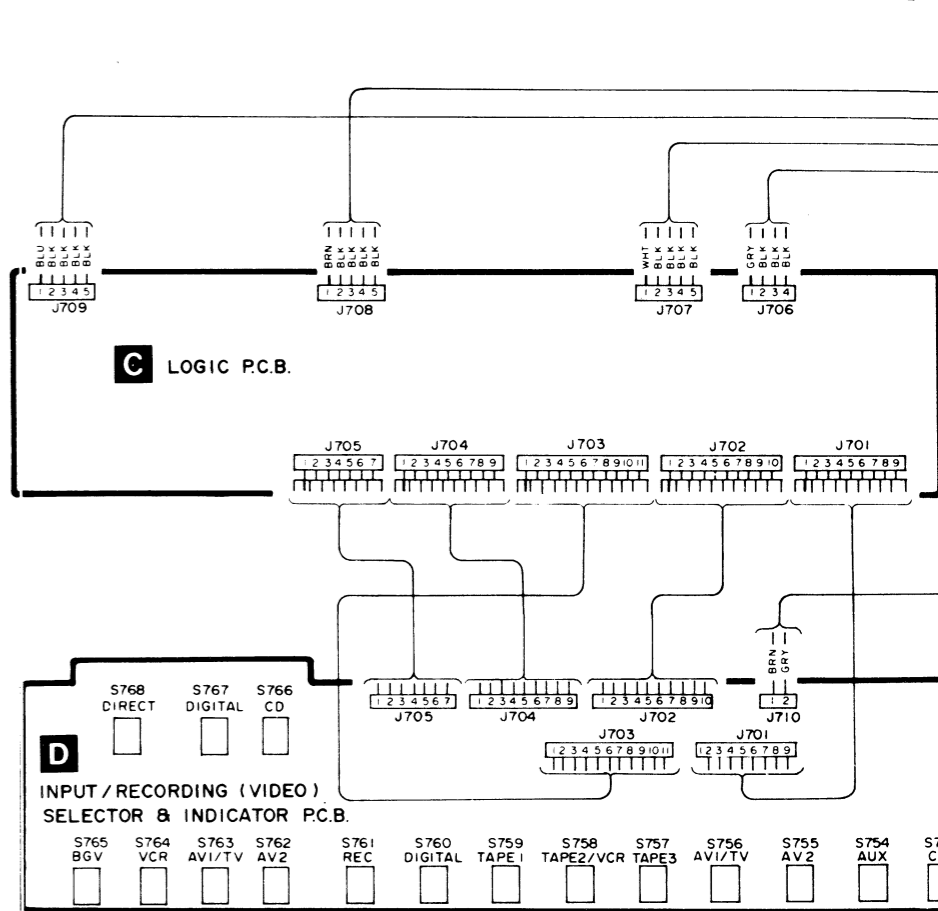
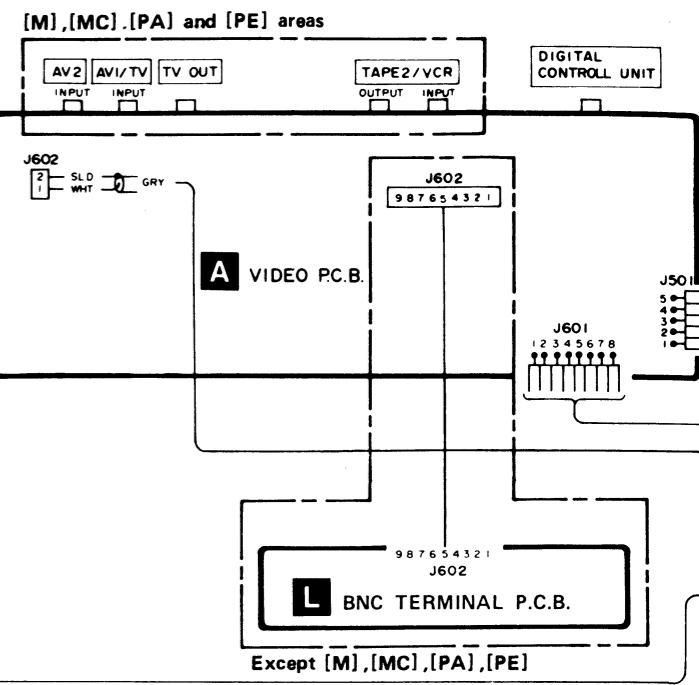

• Terminal guide of transistors, IC's and diodes

M5219P M5238P	8 Pin	2SK389	1. D1 2. G1 3. S1 4. sub 5. S2 6. G2 7. D2	AN78M05 AN78M18	AN79M18	UN4211
MN4001B MN4066B MN4069UB MN74HC02 MN74HC32 SVITC4013BP μPD6360C	14 Pin					
DN74LS145 MN74HC157 SVITD62504P	16 Pin			2SC1815 2SA1015	2SC1384	UN4111
μPD6364CA	24 Pin					
μPD7506CT209	28 Pin					



CONNECTION DIAGRAM

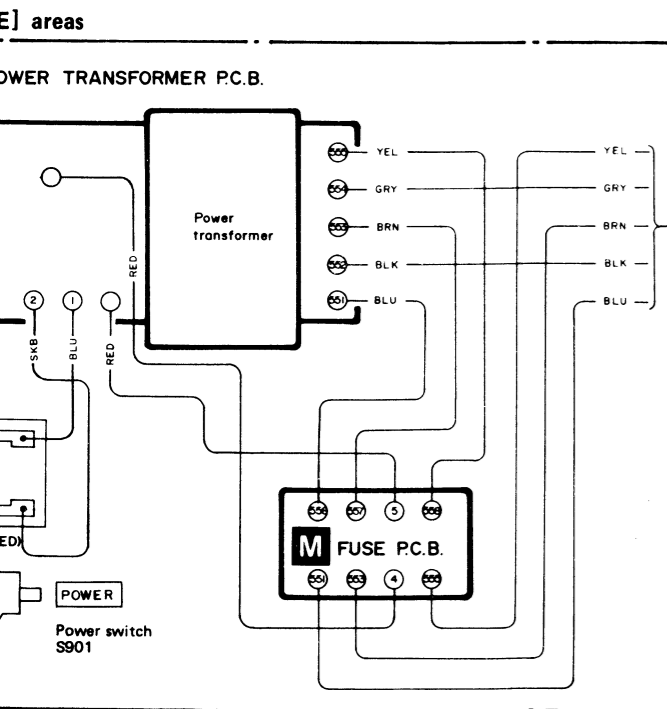
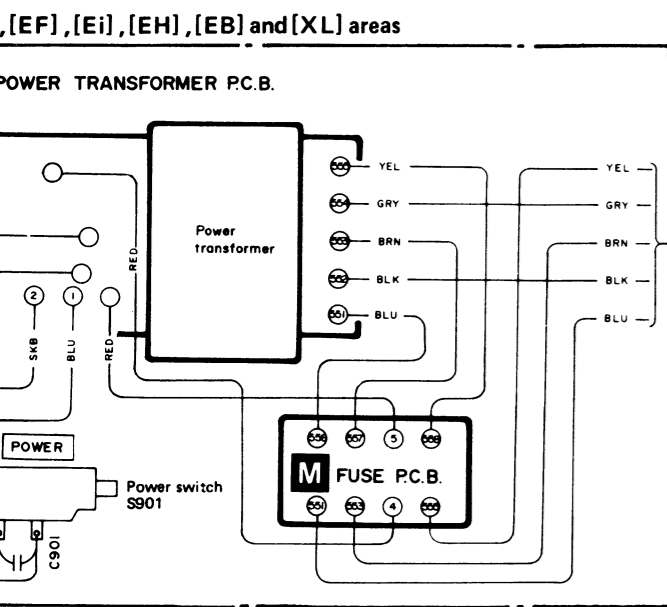
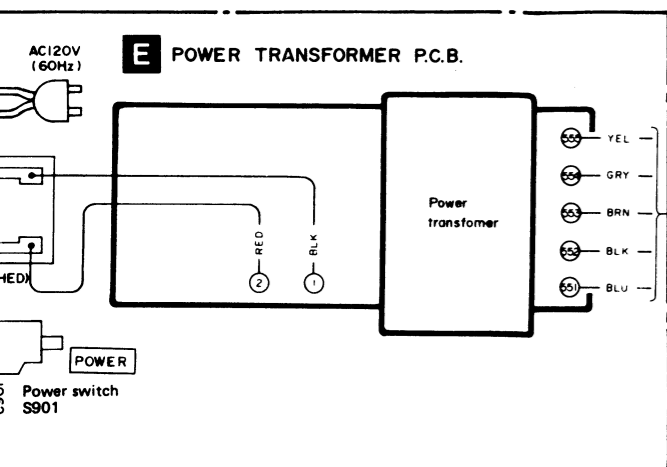

- Note**
- WHT : White
  - RED : Red
  - GRY : Grey
  - BRN : Brown
  - BLK : Black
  - SLD : Shield Line
  - BLU : Blue
  - YEL : Yellow
  - SKB : Sky Blue

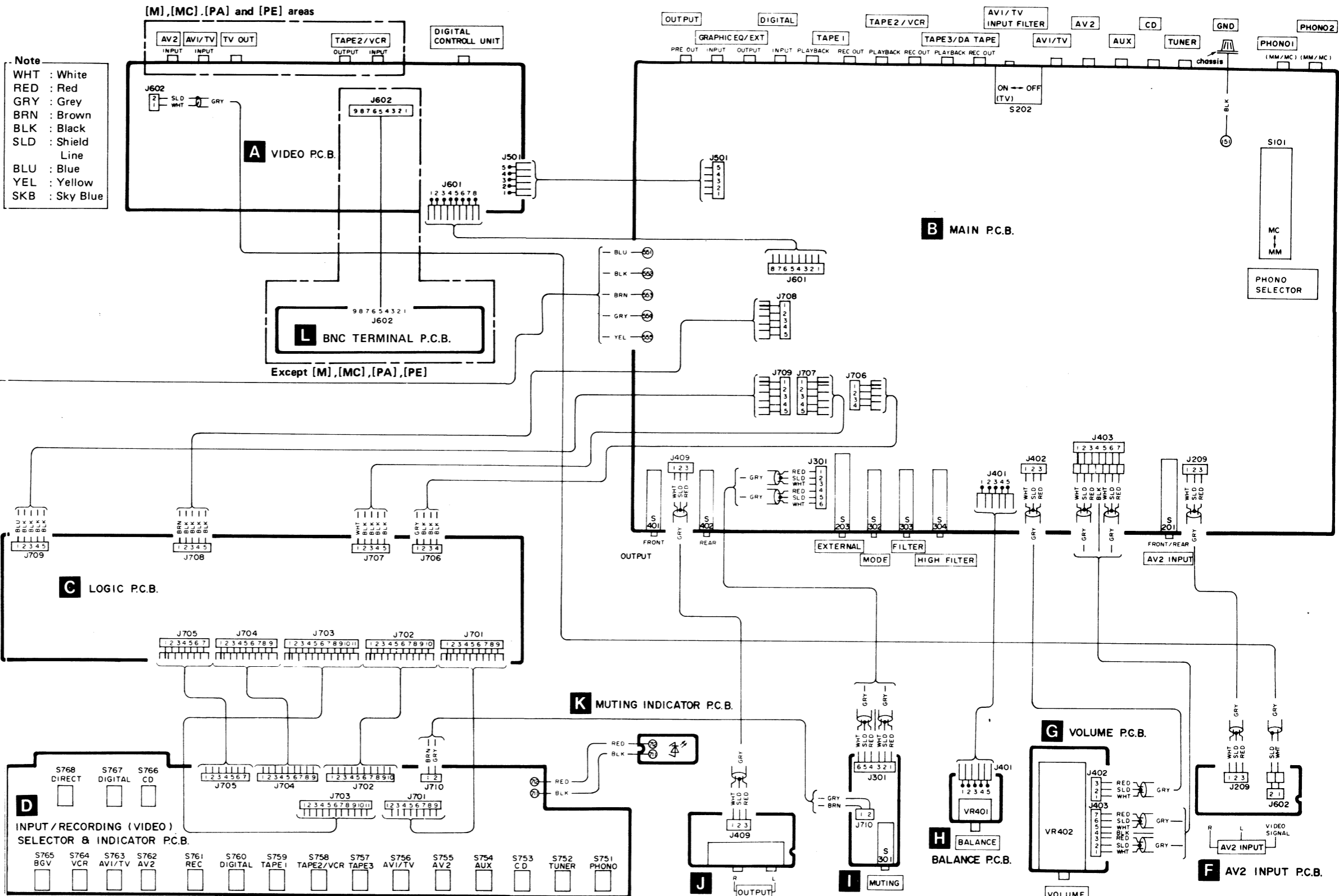

Terminal guide of transistors, IC's and diodes

<p>M5219P M5238P 8 Pin</p> <p>MN4001B MN4066B MN4069UB MN74HC02 MN74HC32 SWIT C4013BP μPD6360C</p> <p>DN74LS145 MN74HC157 SWIT D62504P</p> <p>μPD6364CA 24 Pin</p> <p>μPD7506CT.209 28 Pin</p>	<p>2SK389</p> <p>1. D1 2. G1 3. S1 4. sub 5. S2 6. G2 7. D2</p> <p>D2 D1 G2 S1</p>	<p>AN78M05 AN78M18</p> <p>1 Vin 2 GND 3 Vout</p>	<p>UN4211</p> <p>1. DRAIN 2. GATE 3. SOURCE</p>	<p>2SC3311 2SD1424 2SA1309</p> <p>1. DRAIN 2. GATE 3. SOURCE</p>	<p>2SK369</p> <p>DRAIN SOURCE GATE</p>	<p>LN846RP</p> <p>A K</p>	<p>MA4043M MA4130M MA4062M</p> <p>K A</p>	<p>SVDSR1K2</p> <p>K A</p>
<p>2SC1815 2SA1015</p> <p>2SC1384 2SA1015</p> <p>1. DRAIN 2. GATE 3. SOURCE</p>	<p>UN4111</p> <p>1. DRAIN 2. GATE 3. SOURCE</p>	<p>2SK301</p> <p>1. DRAIN 2. GATE 3. SOURCE</p>	<p>LNQ202YP4</p> <p>1 2 3 4</p>	<p>MC911</p> <p>1 2 3</p>	<p>MA165, MA167 MA29WA, OA91FV</p> <p>K A</p>			

A  
B  
C  
D  
E  
F

### AV2 INPUT CIRCUIT

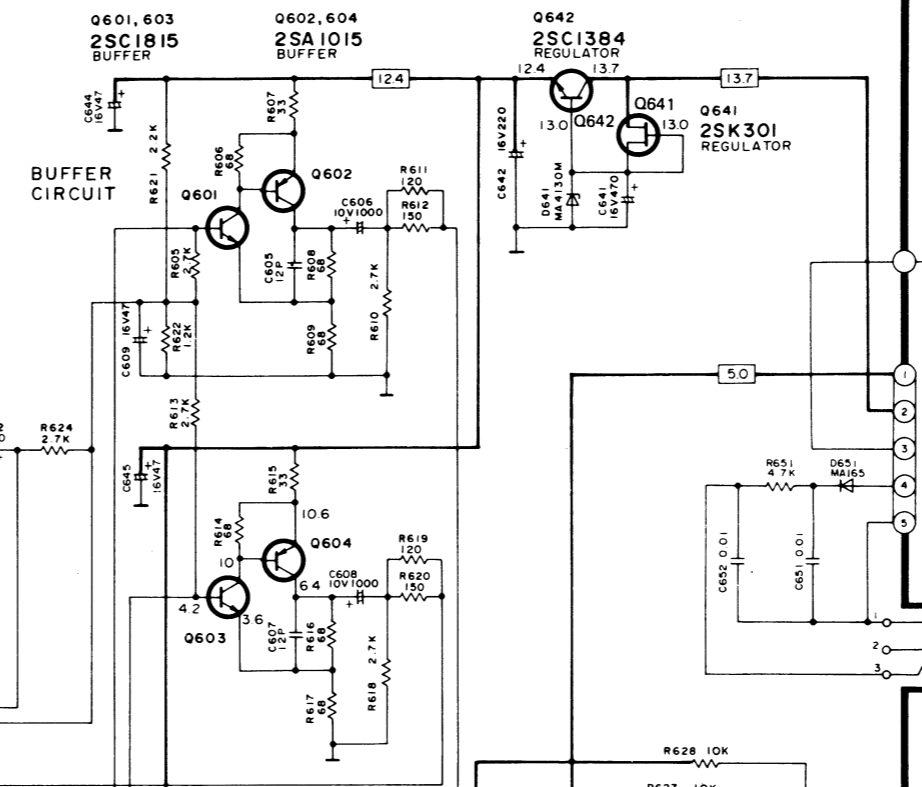
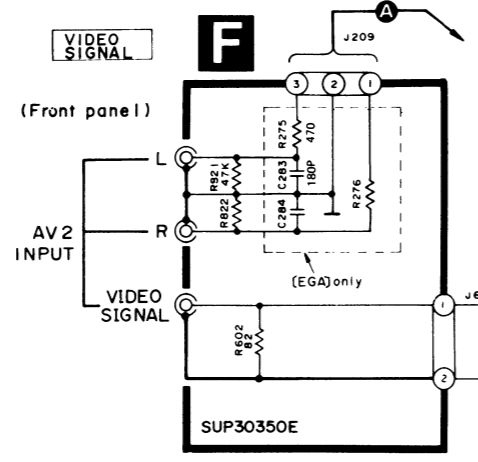

[M],[MC],[PA] and [PE] areas

(Rear panel)

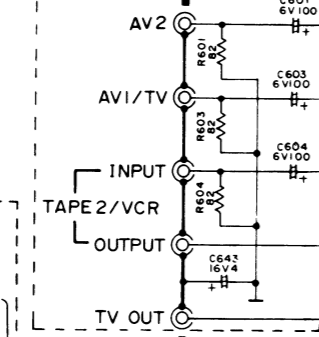

Except [M],[MC],[PA] and [PE] areas

### BNC TERMINAL CIRCUIT

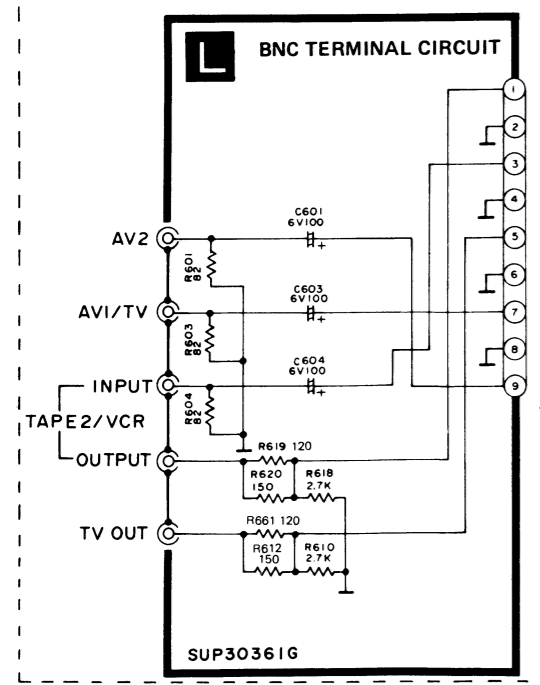

### VIDEO CIRCUIT

SUP30360C

IC604 MN74HC32 INPUT SELECTOR (VIDEO SIGNAL)

VIDEO SIGNAL INPUT SELECT CIRCUIT

AUDIO SIGNAL (L c1)

(Rear panel)

(R c1)

### MAIN CIRCUIT (EGA) only

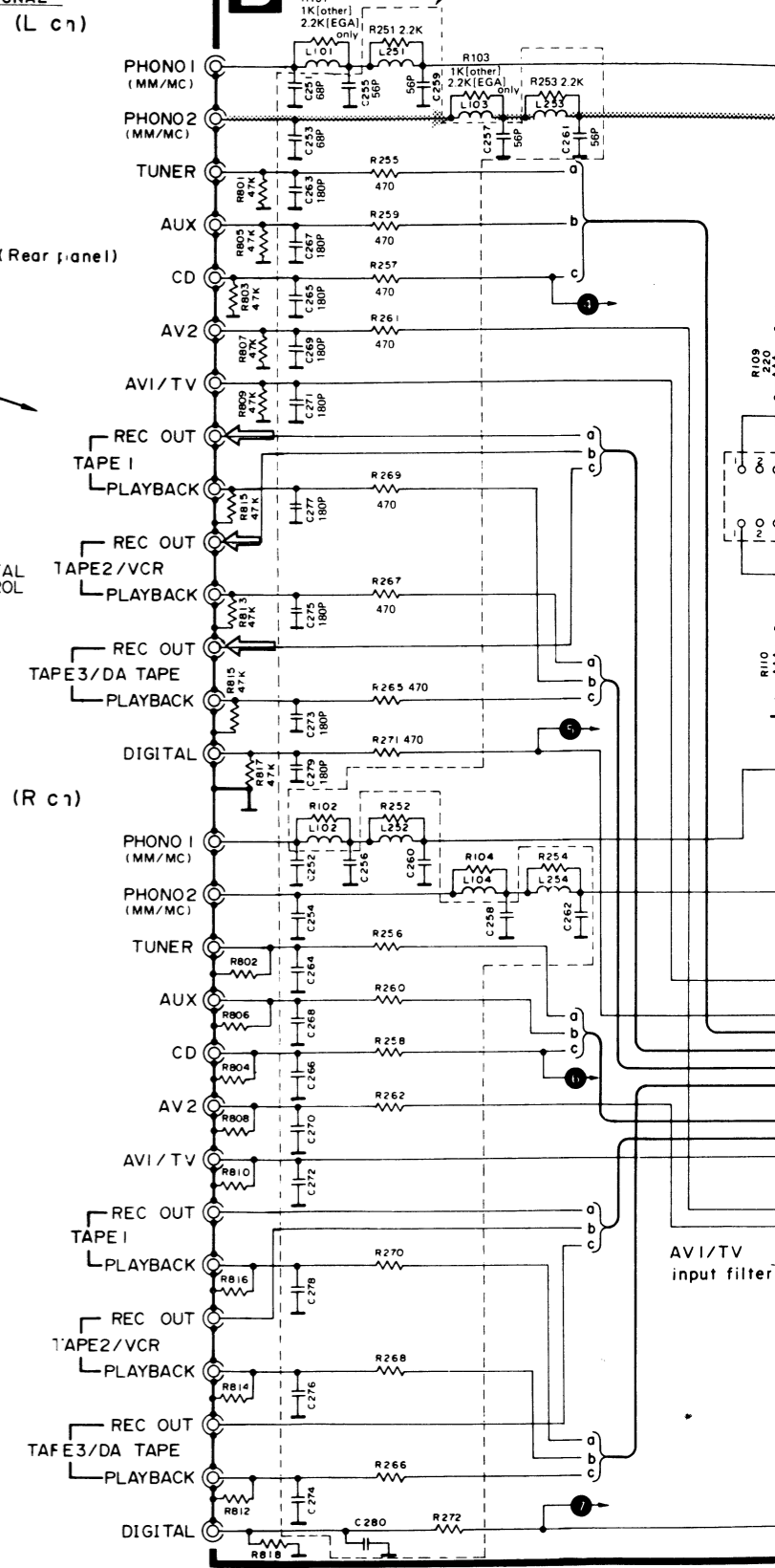

**B MAIN CIRCUIT**

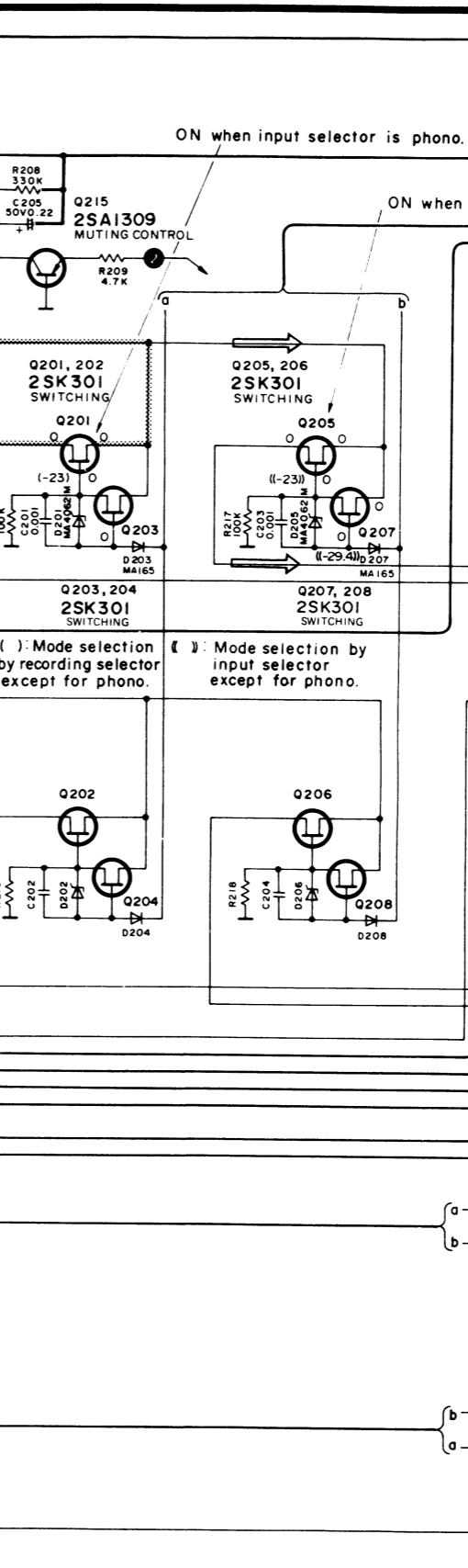
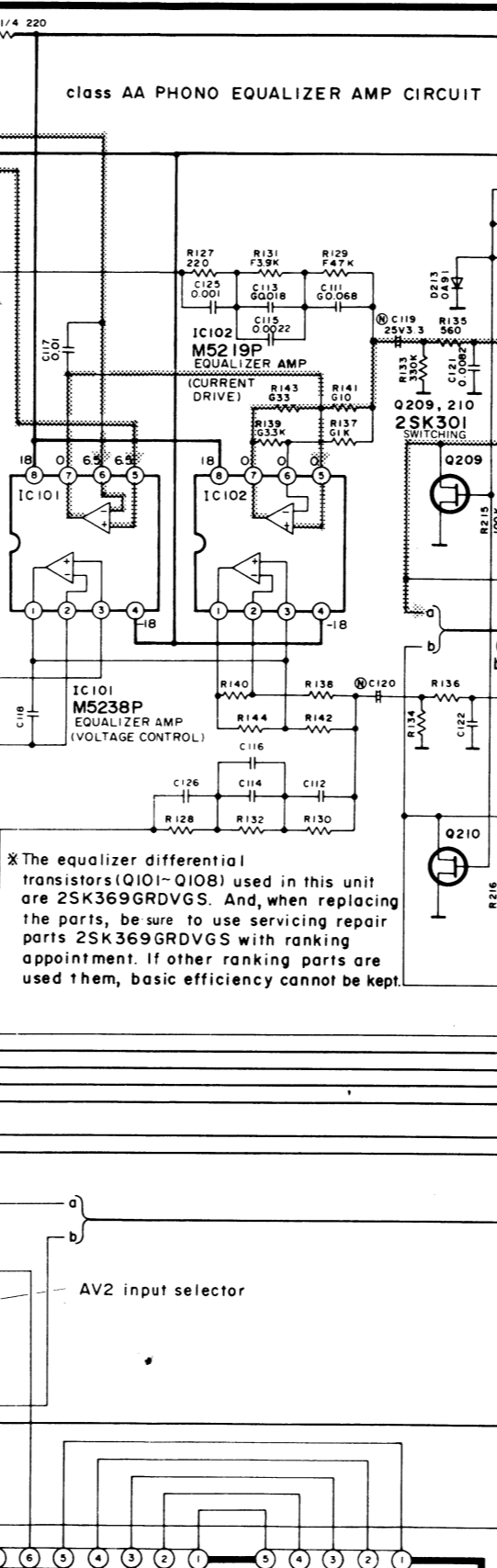
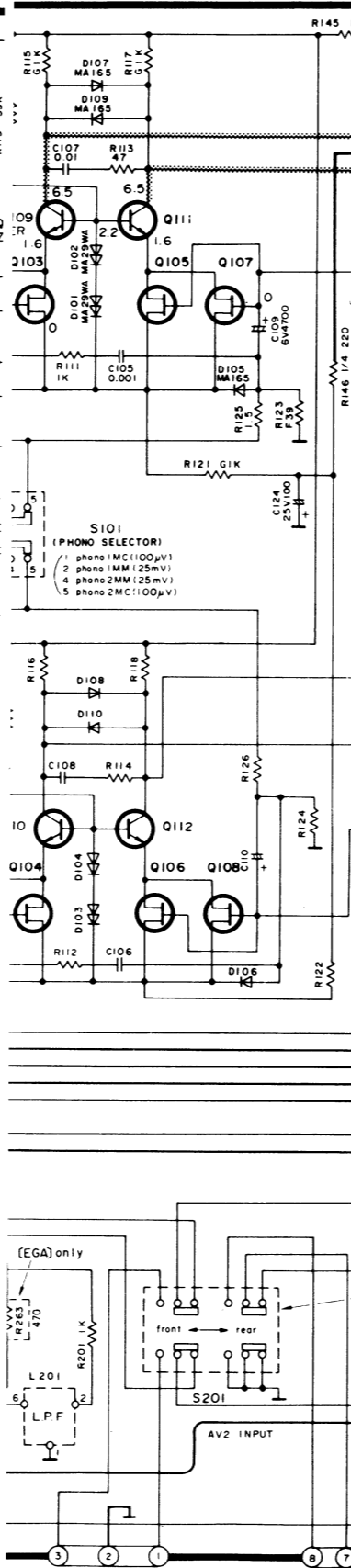
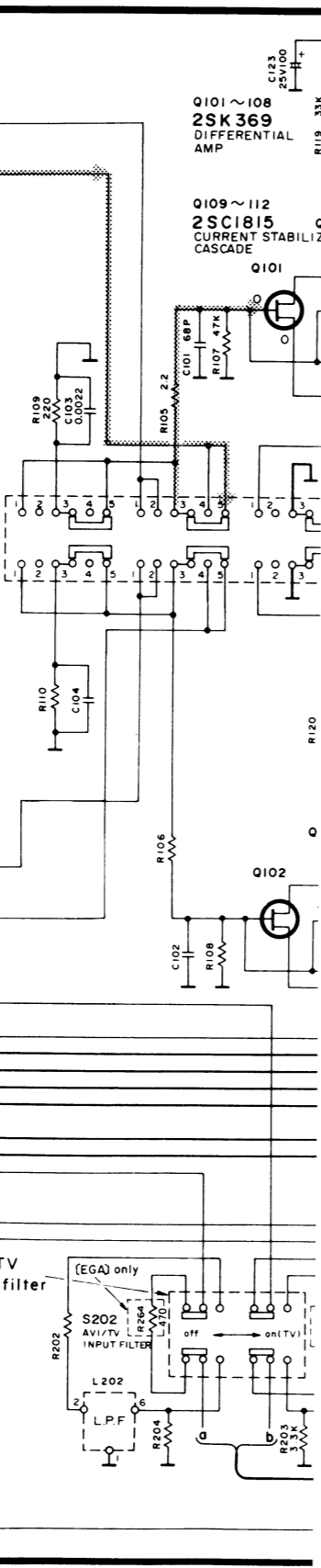
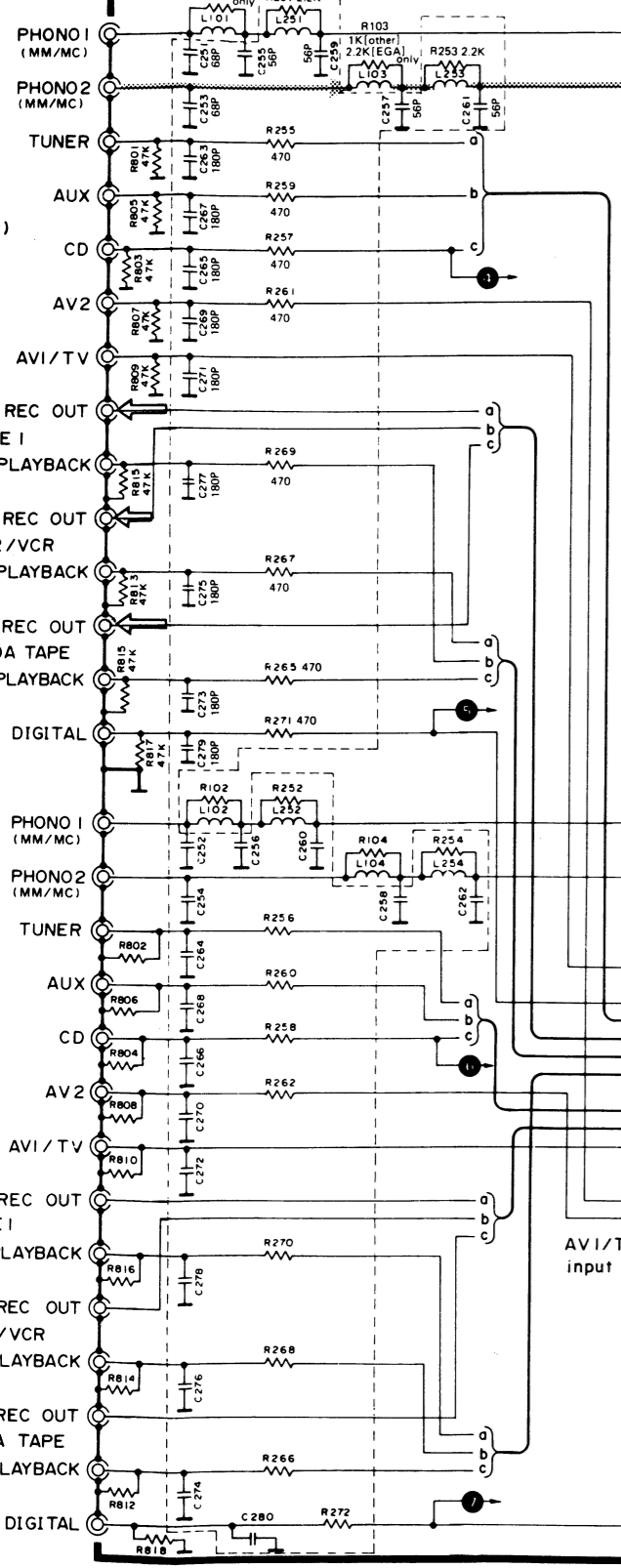

\* The equalizer differential transistors (Q101-Q108) used in this unit are 2SK369GRDVGS. And, when replacing the parts, be sure to use servicing repair parts 2SK369GRDVGS with ranking appointment. If other ranking parts are used them, basic efficiency cannot be kept.

AVI/TV input filter

AV2 input selector

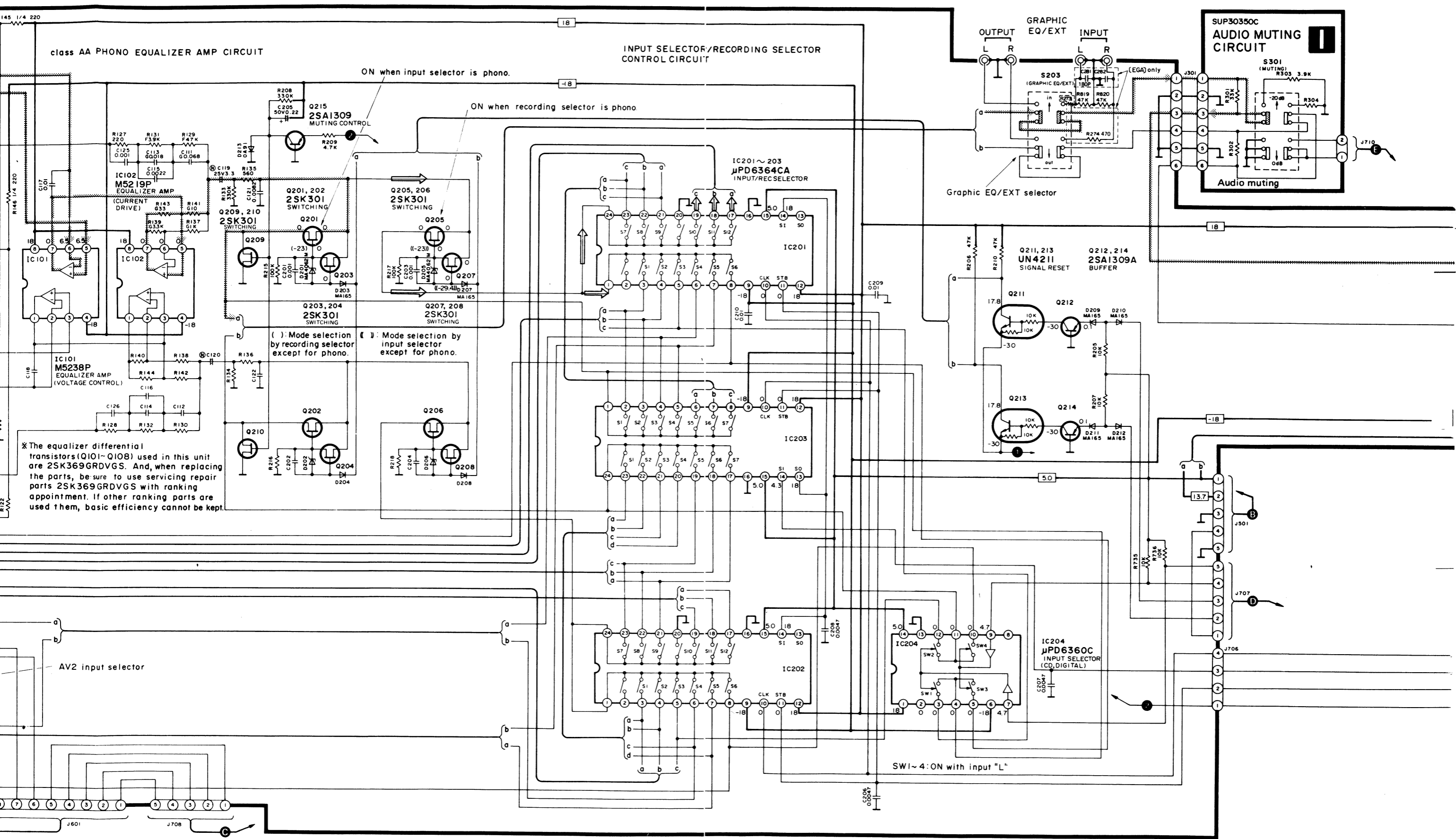

\*The equalizer differential transistors (Q101-Q108) used in this unit are 2SK369GRDVGS. And, when replacing the parts, be sure to use servicing repair parts 2SK369GRDVGS with ranking appointment. If other ranking parts are used them, basic efficiency cannot be kept.

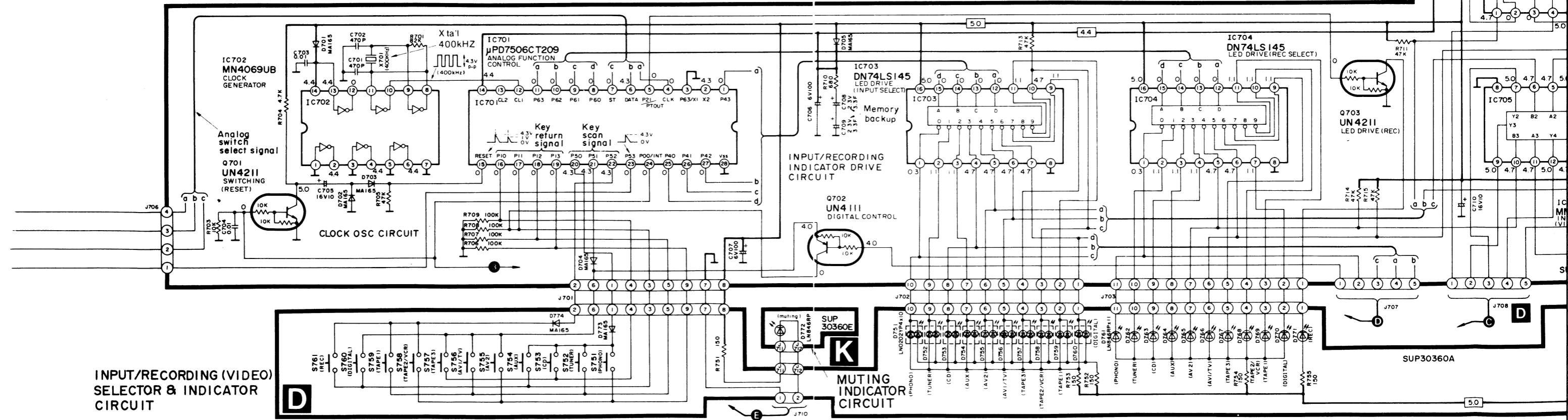
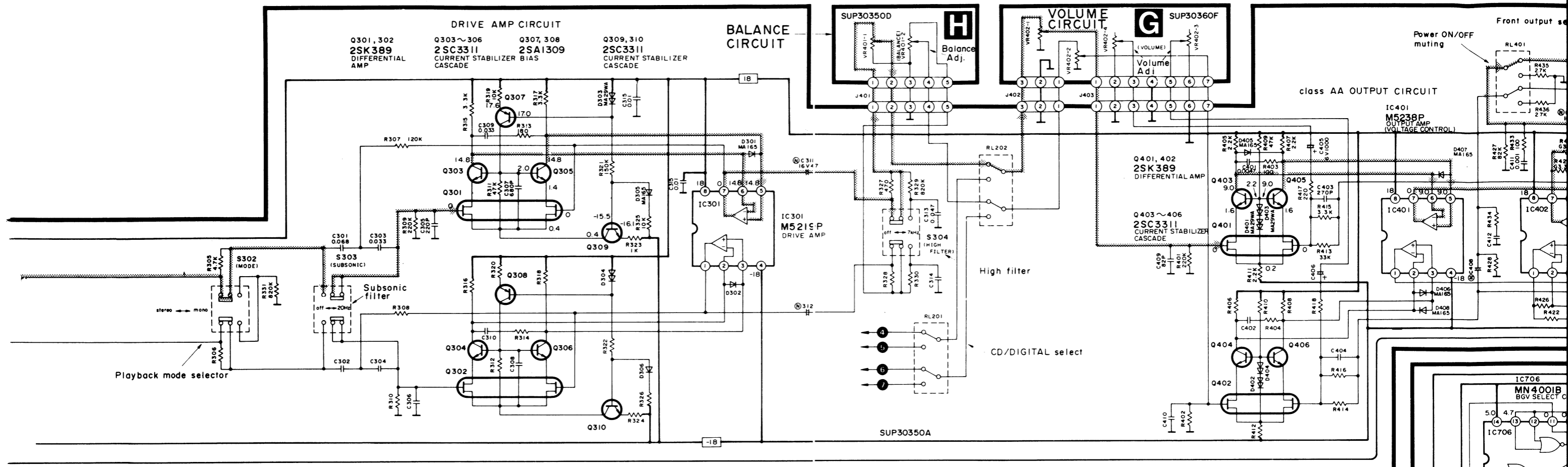

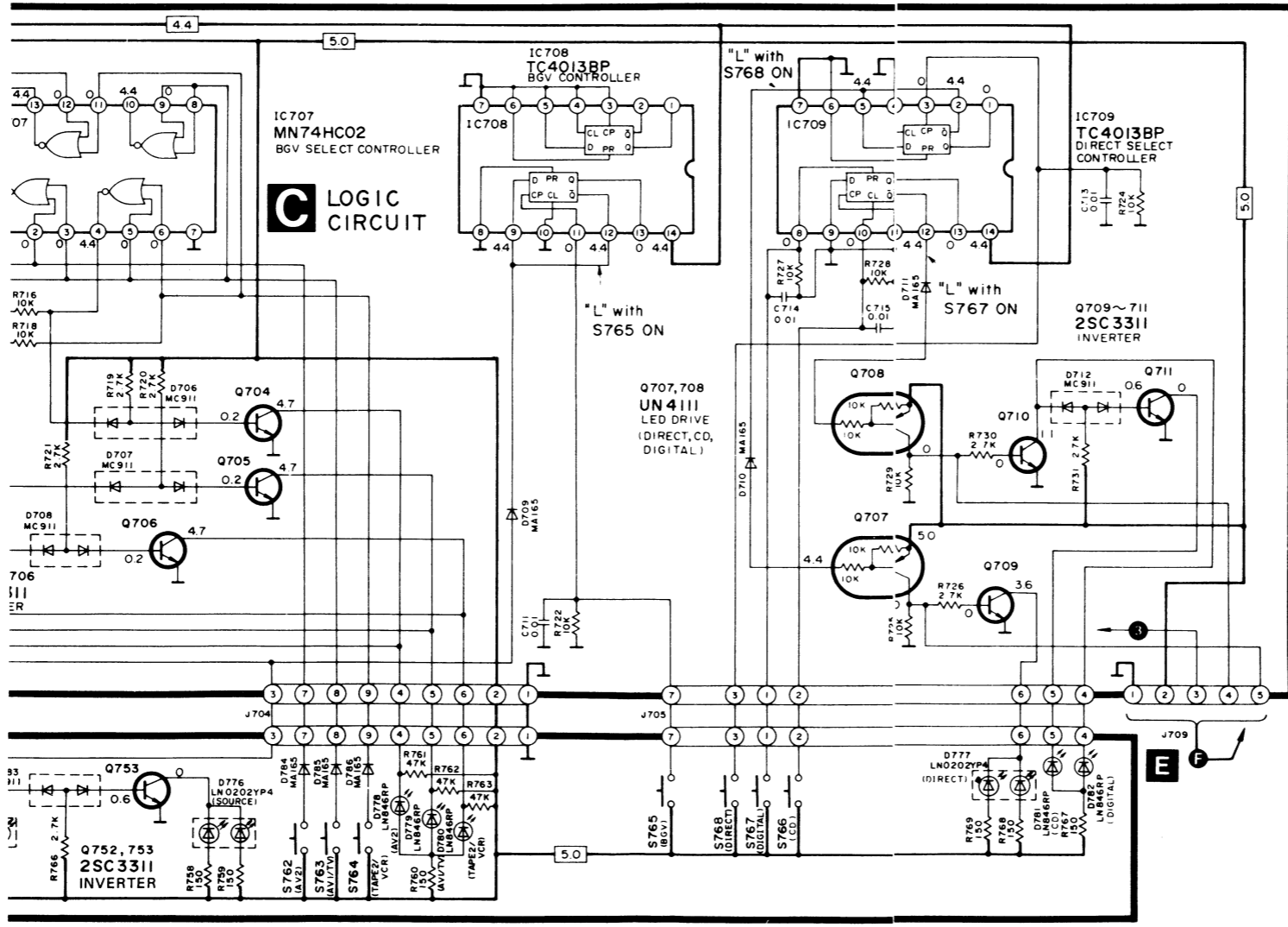
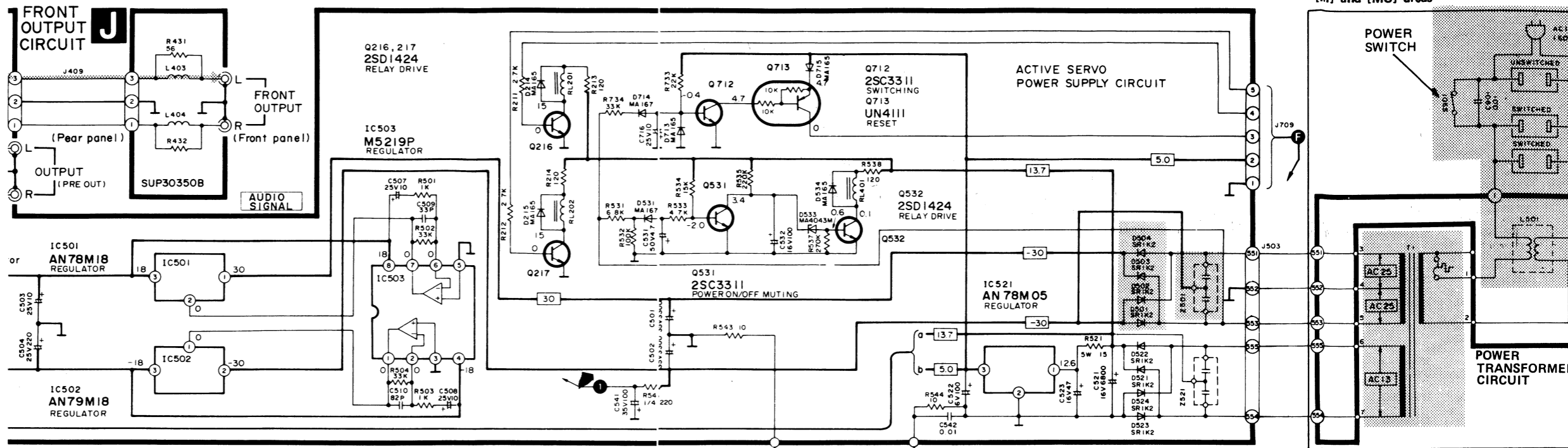
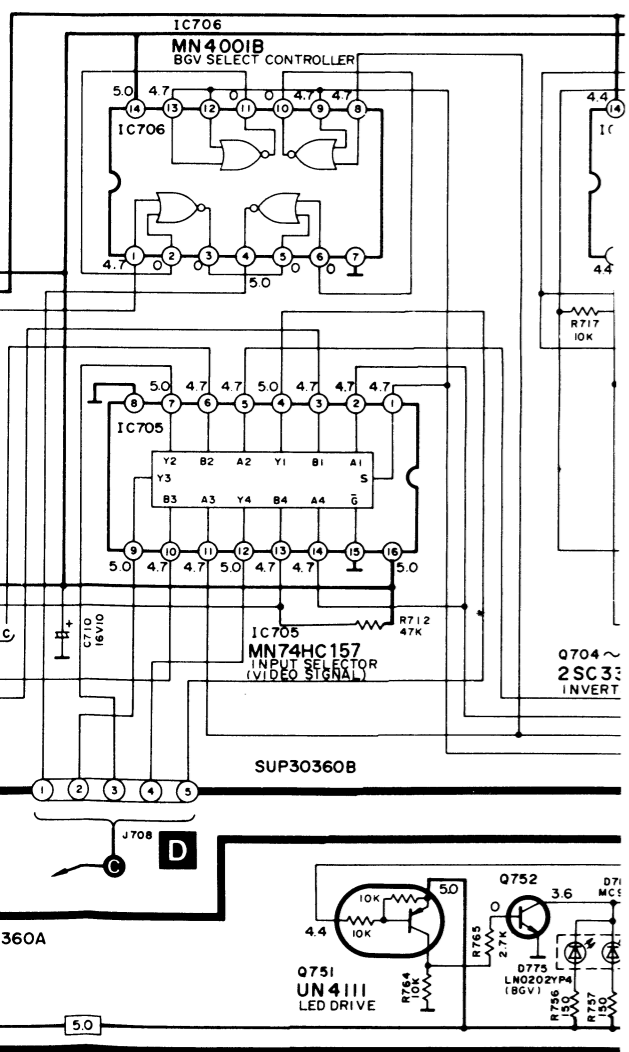
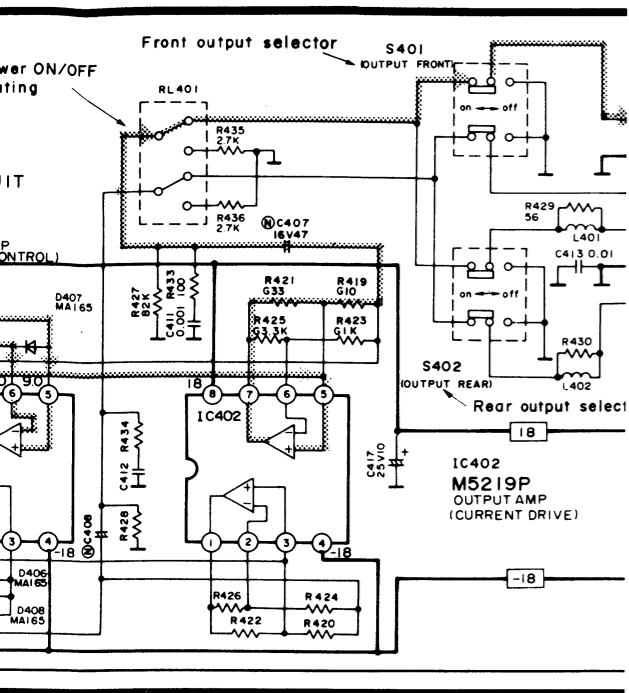

**CIRCUITS TO BE CHANGED AND THE AREAS TO BE CHANGED**  
 [E],[EGA],[EK],[EF],[EH],[Ei],[EB] and [XL] areas

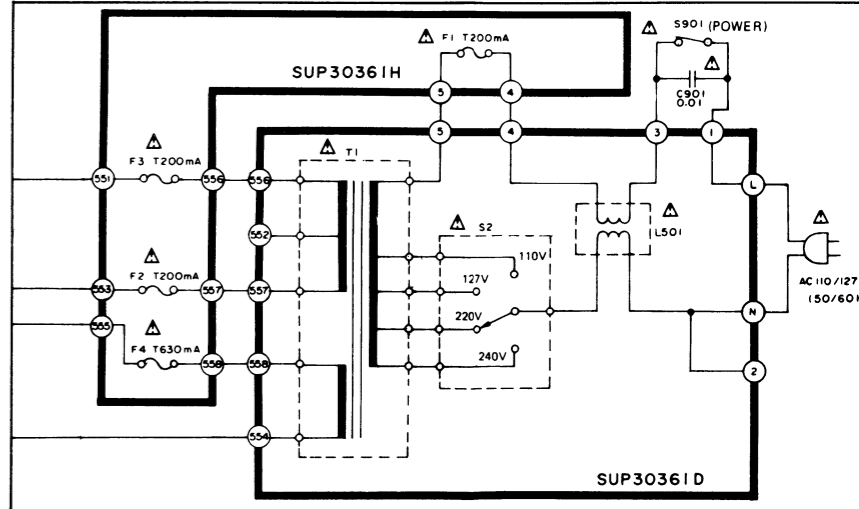

[XA],[PA] and [PE] areas

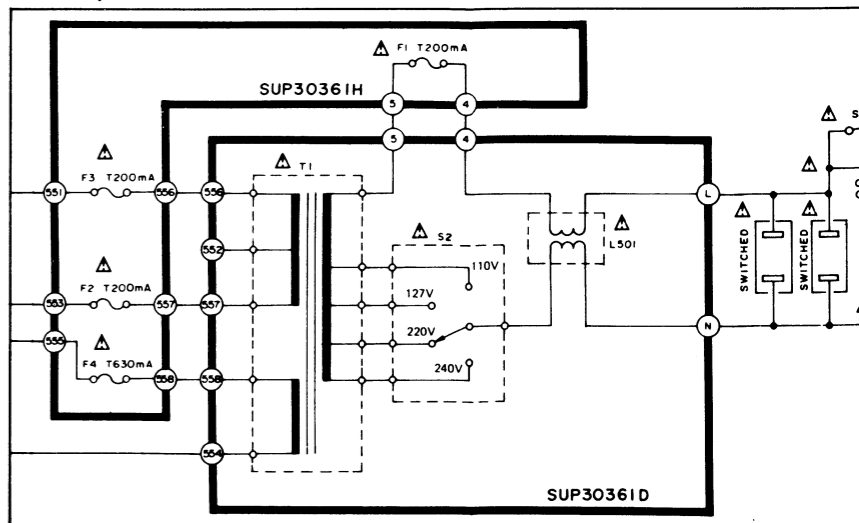



SCHEMATIC DIAGRAM

(This schematic diagram may be modified at any time with the development of new technology.)

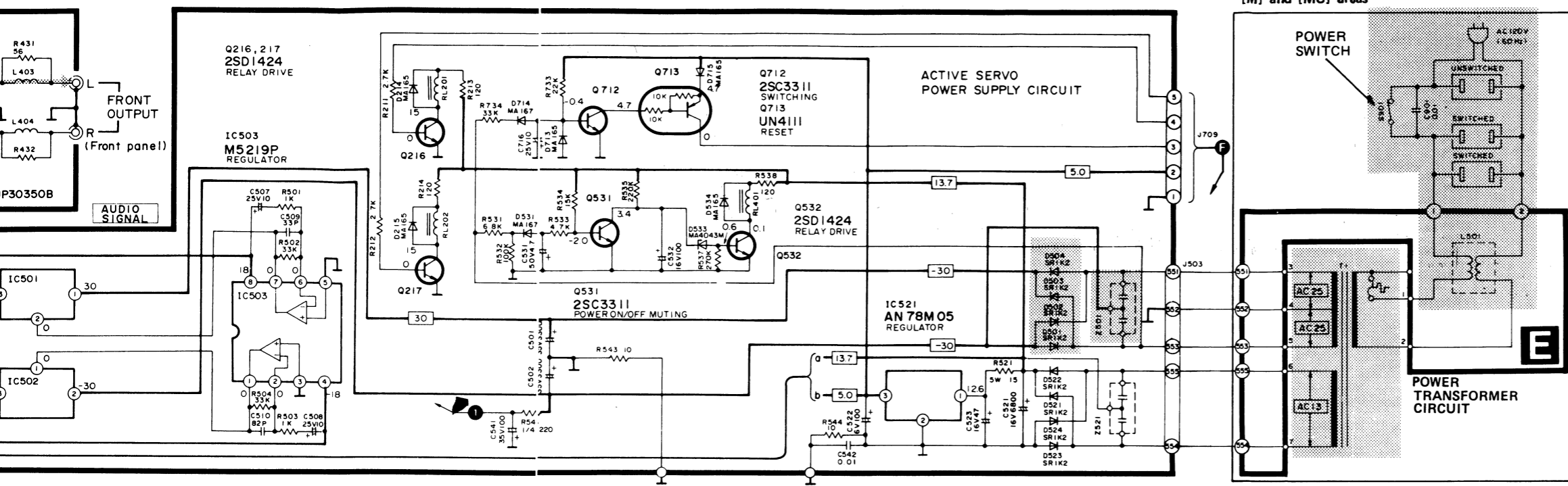

- Notes:**
- S2** (For [E], [EGA], [EK], [EF], [EH], [Ei], [EB], [XL], [XA], [PA] and [PE] areas) : Voltage selector switch "220V" position. (127V ↔ 110V ↔ 220V ↔ 240V)
  - S101** : Phono selector in "MC" position. (MC ↔ MM)
  - S201** : AV2 input selector in "rear" position. (rear ↔ front)
  - S202** : AV1/TV input filter switch in "off" position. (off ↔ on [TV])
  - S203** : Graphic EQ/external selector in "output" position. (output ↔ input)
  - S301** : Muting switch in "0dB" position. (0dB ↔ 20dB)
  - S302** : Playback mode selector in "stereo" position. (stereo ↔ mono)
  - S303** : Subsonic filter switch in "off" position. (off ↔ 20Hz)
  - S304** : High filter switch in "off" position. (off ↔ 7kHz)
  - S401** : Front output switch in "on" position. (on ↔ off)
  - S402** : Rear output switch in "on" position. (on ↔ off)
  - S751 ~ S760** : Input/recording selector. [S751-phono, S752-tuner, S753-CD, S754-aux, S755-AV2, S756-AV1/TV, S757-tape, S758-tape 2/VCR, S759-tape 1, S760-digital]
  - S761** : Recording mode selector.
  - S762 ~ S764** : BGV selector [S762-AV2, S763-AV1/TV, S764-tape 2/VCR]
  - S765** : BGV mode selector.
  - S766, S767** : Direct selector. [S766-CD, S767-digital]
  - S768** : Direct selector.
  - S901** : Power switch in "on" position.
- Important safety notice:** Components identified by  $\Delta$  mark have special characteristics important for safety. When replacing any of these components, use only manufacturer's specified parts.
- All voltage values shown in circuitry are the standard values for the DC electronic circuit tester (high-impedance) with the chassis taken as standard. Therefore, there may exist some errors in the voltage values, depending on the internal impedance of the DC circuit tester.
- Phono playback signal (L ch.)  
Phono recording signal (L ch.)  
Positive voltage lines and Negative voltage lines

CIRCUITS TO BE CHANGED AND THE AREAS

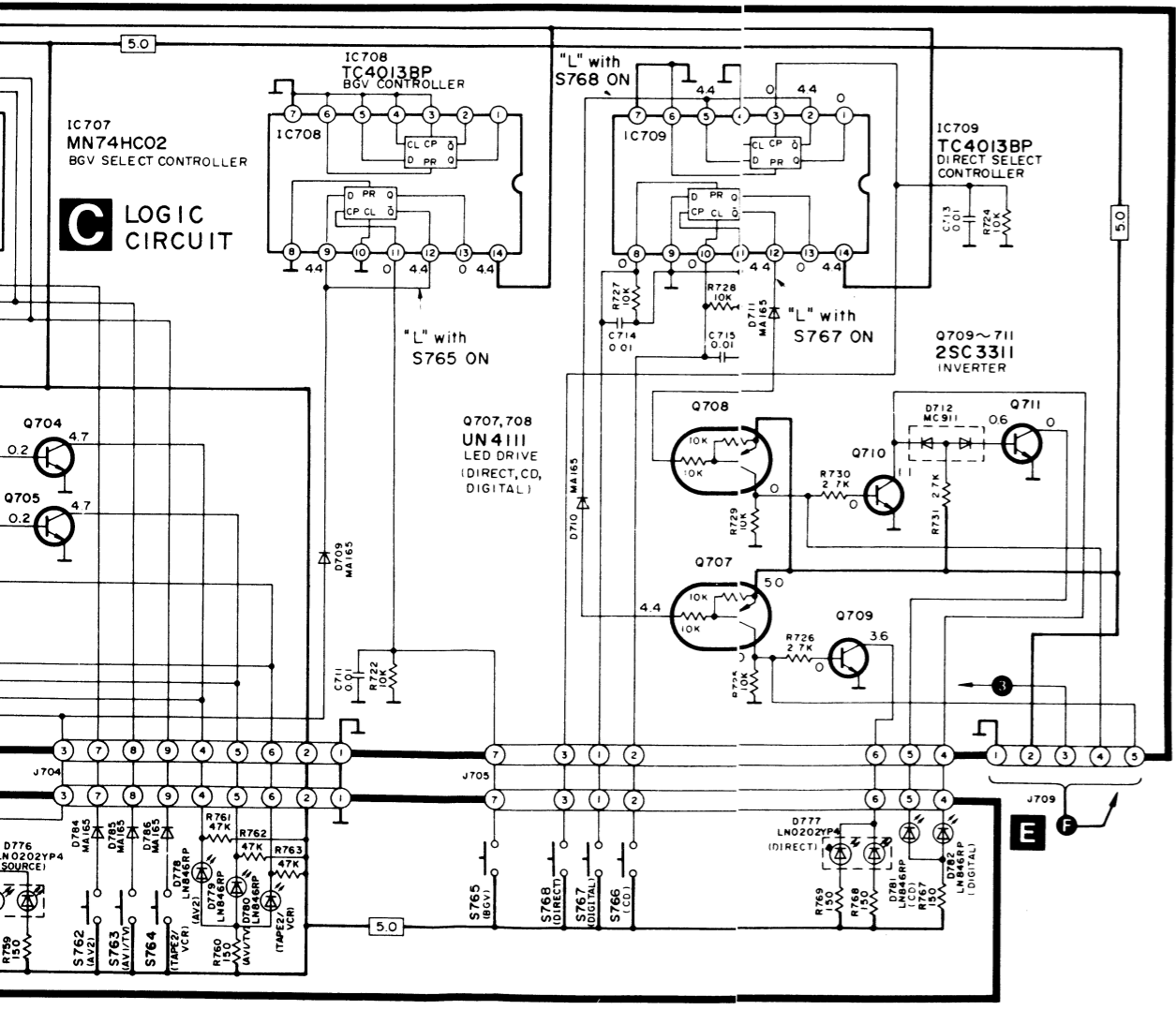
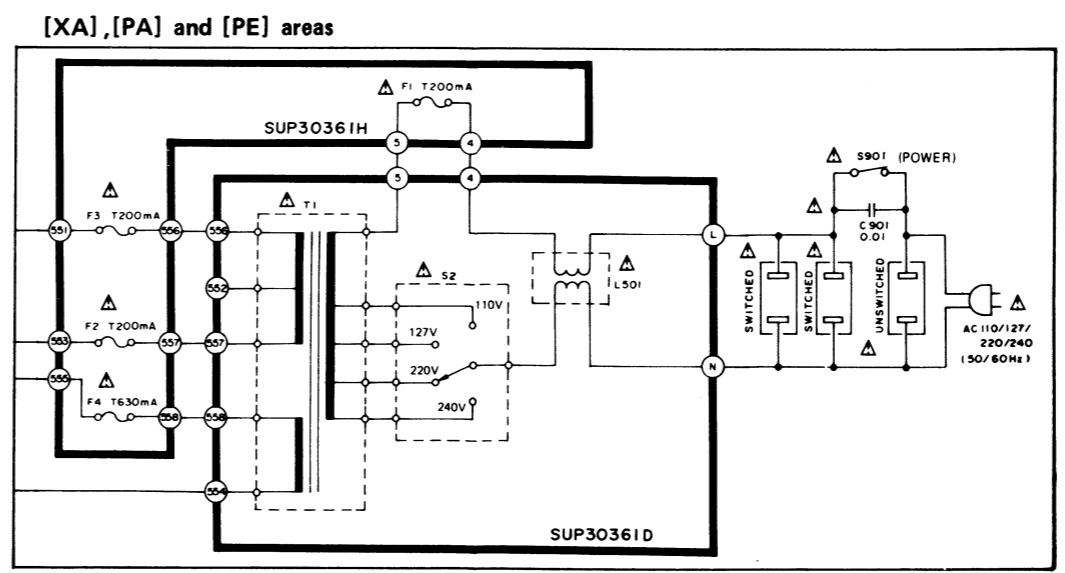
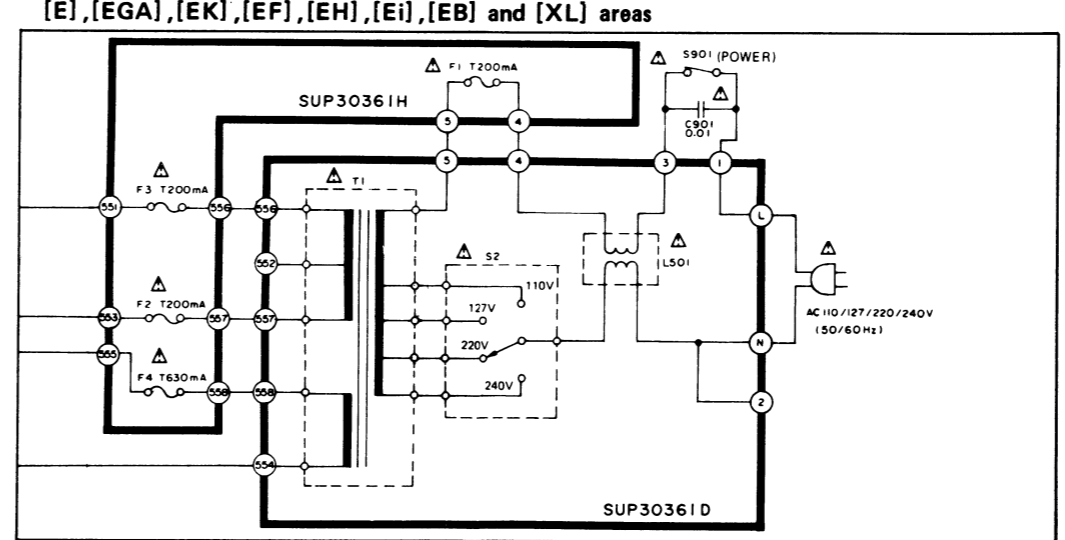

**IMPORTANT SAFETY NOTICE**

The shaded area on this schematic diagram incorporates special features important for protection from fire and electrical shock hazards. When servicing, it is essential that only manufacturer's specified parts be used for the critical components in the shaded areas of the schematic.

- \* Caution !**
- IC and LSI are sensitive to static electricity. Secondary trouble can be prevented by taking care during repair.
  - \* Cover the parts boxes made of plastics with aluminum foil.
  - \* Ground the soldering iron.
  - \* Put a conductive mat on the work table.
  - \* Do not touch the legs of IC or LSI with the fingers directly.

REPLACEMENT PARTS LIST

- Notes: 1. Part numbers are indicated on most mechanical parts. Please use this part number for parts order. 2. Important safety notice: Components identified by a triangle mark have special characteristics important for safety. When replacing any of these components, use only manufacturer's specified parts. 3. Bracketed indications in Ref. No. columns specify the area. Parts without these indications can be used for all areas. 4. The "S" mark is service standard parts and may differ from production parts. 5. The parenthesized numbers in the column of description stand for the quantity per set.

CAPACITORS

Table with columns: Ref. No., Part No., Value. Lists various capacitor models like ECDD1H680K, ECQB1H222JZ, etc.

Table with columns: Ref. No., Part No., Description. Includes sections for INTEGRATED CIRCUIT, TRANSISTORS, DIODES, COILS, and CRYSTAL.

Table with columns: Ref. No., Part No., Description. Includes sections for VARIABLE RESISTORS, COMPOUND COMBINATIONS, FUSES, SWITCHES, TRANSFORMER, and RELAY.

Table with columns: Ref. No., Part No., Description. Includes sections for CABINET and CHASSIS.

Table with columns: Ref. No., Part No., Description. Lists various mechanical parts like SUE25-1, SGL233-1, SGX7814, etc.

Table with columns: Ref. No., Part No., Description. Lists various electrical components like SKCUA200-KM, SNEA204-1S, SNTA421-1, etc.

Table with columns: Ref. No., Part No., Description. Lists various fasteners and accessories like SHR9777, SMC6381-1, XTBS3+8FFZ1, etc.



EXPLODED VIEW

Part No.	Description	Ref. No.	Part No.	Description
SKCUA200-KM	Top Cover Ass'y	(1)	95 Except [M, MC, PA, PE]	SHR9777 Bake Plate, BNC Terminal
SKCUA200-KK	Top Cover Ass'y	(1)	96 Except [M, MC, PA, PE]	SMC6381-1 Shield Plate, BNC Terminal
SKCUA200-KE	Top Cover Ass'y	(1)	97 Except [M, MC]	SJT347 Fuse Holder
SNEA204-1S	Terminal, Ground	(2)	<b>SCREWS, WASHERS and NUTS</b>	
SNTA421-1	Nut, Ground	(2)	N1 [M, MC]	XTBS3+8FFZ1 Tapping, $\pm 3 \times 8$
RJT204A	Spacer, Ground	(2)	N1 [other]	XTBS3+8FFZ1 Tapping, $\pm 3 \times 8$
SUW2985-1	Lug, Ground	(1)	N2	XTB3+8FFZ Tapping, $\pm 3 \times 8$
ESA335025B	Bracket	(1)	N2 [other]	XTB3+8FFZ Tapping, $\pm 3 \times 8$
SJPA11-1	Phono Selector	(1)	N3	XTW3+8T Tapping, $\pm 3 \times 8$
SQX40026	Short-pin	(22)	N4	XTB4+8FFZ Tapping, $\pm 4 \times 8$
	Caution, Terminal of CD	(1)	N5 [M, MC, PA, PE]	XTB3+8GFZ Tapping, $\pm 3 \times 8$
			N5 [other]	XTB3+8GFZ Tapping, $\pm 3 \times 8$
SJT30543-V	Connector (5 pin)	(1)	N6	XYNS3+C6-1S $\pm 3 \times 6$
SJT30843-V	Connector (8 pin)	(1)	N6 [M, MC]	XYNS3+C6-1S $\pm 3 \times 6$
	(J601)		N6 [other]	XYNS3+C6-1S $\pm 3 \times 6$
SJT783	Terminal, Connector	(79)	N7	XTW3+8H Tapping, $\pm 3 \times 8$
SJS5215	Connector, (2 pin)	(2)	N7 [M, MC, PA, PE]	XTW3+8H Tapping, $\pm 3 \times 8$
SJS5331	Connector, (3 pin)	(1)	N7 [other]	XTW3+8H Tapping, $\pm 3 \times 8$
SJS5425	Connector, (4 pin)	(1)	N8	XSS5+12F1S Side Panel
SJS5523	Connector, (5 pin)	(3)	N9	SNE2095-6 Top Cover
SJS5715	Connector, (7 pin)	(2)	N10	XTB3+10GFZ Tapping, $\pm 3 \times 10$
SJS5907	Connector, (9 pin)	(2)	N11	XTW3+6T Tapping, $\pm 3 \times 6$
SJS5025	Connector, (10 pin)	(1)	N12	SNE4021-1 Nut
SJS5031	Connector, (11 pin)	(1)	N13	XWC9A Washer
	(J703)		N14	XNS8FZ Nut
SJT3213	Post, (2 pin)	(1)	N15	XTB3+6JFZ Tapping, $\pm 3 \times 6$
SJT3319	Post, (3 pin)	(1)	N16	XXE4D5FZS Nut
SJT3415	Post, (4 pin)	(1)	N17	XTB3+14JFZ Tapping, $\pm 3 \times 14$
SJT3511	Post, (5 pin)	(3)		
SJT3709	Post, (7 pin)	(2)		
SJT3907	Post, (9 pin)	(2)		
SJT3005	Post, (10 pin)	(1)		
SJT3011	Post, (11 pin)	(1)		
SJT785	Terminal, Socket	(139)		
SJS5217	Socket, (2 pin)	(2)		
SJS5337	Socket, (3 pin)	(17)		
SJS5431	Socket, (4 pin)	(1)		
SJS5529	Socket, (5 pin)	(3)		
SJS5633	Socket, (6 pin)	(2)		
SJS5717	Socket, (7 pin)	(2)		
SJS5911	Socket, (9 pin)	(2)		
SJS5027	Socket, (10 pin)	(1)		
SJS5049	Socket, (11 pin)	(1)		
SJT3215	Post, (2 pin)	(1)		
SJT5901	Post, (9 pin)	(1)		
SJT3901	Connector, (9 pin)	(1)		
SJT781	Terminal, Connector	(1)		
SJT3509	Connector, (5 pin)	(1)		
SJS5521	Post, (5 pin)	(1)		
SMN1912	Bracket, Voltage Selector	(1)		
SHD3X21	Spacer, Fuse P.C.B.	(4)		
SUW1617-2	Bracket, Video P.C.B.	(4)		
SHR401-1	Lock Pin	(3)		
SJS104	Terminal W/Washer and Nut, BNC	(5)		

Ref. No.	Part No.	Description
<b>ACCESSORIES</b>		
A1	SFDHM03N02	Connection Cord, Audio
A2	TSX299	Connection Cord, Video
A2 [M, MC, PA, PE]		
A2 [other]	SJP2195	Connection Cord, BNC
A3 Except [M, MC, PA, PE]	SJP9005	Plug, BNC Adaptor
A3 [XA, PA, PE]	SJP9215	Plug, AC Adaptor
A4 [M]	SQF12629	Instruction Book
A4 [MC]	SQF12630	Instruction Book
A4 [E]	SQF12631	Instruction Book
A4 [EGA]	SQF12632	Instruction Book
A4 [XA]	SQF12633	Instruction Book
A4 [PA, PE]	SQF12634	Instruction Book
A4 [EK, XL]	SQF12635	Instruction Book
<b>PACKING</b>		
P1 [MC]	SPG5515	Carton Box
P1 [EK]	SPG5516	Carton Box
P1 [XL]	SPG5517	Carton Box
P1 [EF]	SPG5518	Carton Box
P1 [other]	SPG5514	Carton Box
P2 [XL]	SPS3023-8	Pad (Left)
P2 [other]	SPS3023-7	Pad (Left)
P3 [XL]	SPS3025-7	Pad (Right)
P3 [other]	SPS3025-6	Pad (Right)
P4	SPS4488	Pad (Top)
P5	SPS4703	Pad (Corner)
P6	SPH220	Paper Sheet
P7	SPP723	Polyethylene Sheet

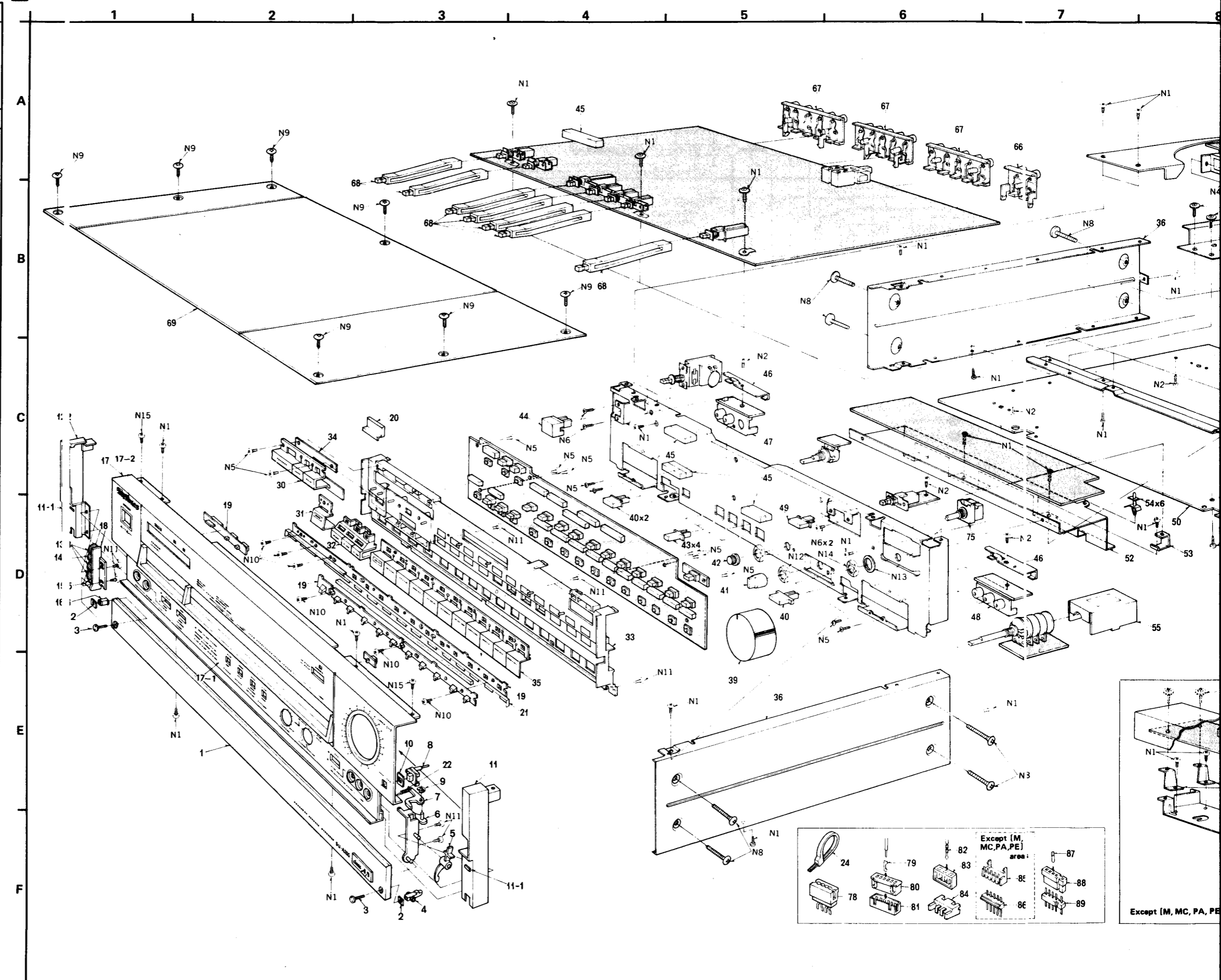

02020621  
SM-SUA200  
SVC MNL  
91000123  
DOM/PX/AC/MM  
1 ST  
32

