

Service Manual

Stereo Integrated Amplifier

Amplifier

SU-A900MK2

Colour

(K) Black Type



Areas

Suffix for Model No.	Area	Colour
(E)	Europe	(K)
(EB)	Great Britain	
(EG)	Germany and Italy	
(GC)	Asia, Latin America, Middle Near East and Africa	
(GN)	Oceania	

Specifications (DIN 45 500)

20 Hz – 20 kHz continuous power output both channels driven	2 × 90 W (8 Ω)
1 kHz continuous power output both channels driven (THD: 1%)	2 × 100 W (8 Ω) 2 × 140 W (4 Ω)
63 Hz – 12.5 kHz continuous power output both channels driven (THD: 0.7%)	2 × 90 W (8 Ω) 2 × 125 W (4 Ω)
Total harmonic distortion rated power at 20 Hz – 20 kHz	0.01% (8 Ω)
Intermodulation distortion (50 Hz: 7 kHz = 4:1, SMPTE) rated power	0.007% (8 Ω)
Residual hum and noise	1 mV
Damping factor	60 (8 Ω) 30 (4 Ω)
Headphones output level/impedance	540 mV/330 Ω
Load impedance	
A or B	4 – 16 Ω
A and B	8 – 16 Ω
Input sensitivity/impedance	
PHONO MM	2.5 mV/47 kΩ
PHONO MC	170 μV/220 Ω
TUNER, CD, AUX, TAPE 1, TAPE 2/DCC	150 mV/22 kΩ
Phono maximum input voltage (1 kHz, RMS)	
MM	160 mV (IHF '66)
MC	12 mV (IHF '66)
S/N (rated power, 4 Ω)	
PHONO MM	78 dB (85 dB, IHF '66)
PHONO MC	64 dB (S = 250 μV, 66 dB, IHF '66)
TUNER, CD, AUX, TAPE 1, TAPE 2/DCC	91 dB (100 dB, IHF '66)
S/N at – 26 dB power (4 Ω)	
PHONO MM	68 dB
PHONO MC	63 dB
TUNER, CD, AUX, TAPE 1, TAPE 2/DCC	70 dB

S/N at 50 mW power (4 Ω)

PHONO MM	64 dB
TUNER, CD, AUX, TAPE 1, TAPE 2/DCC	64 dB
Frequency response	
PHONO MM	RIAA standard curve ±0.8 dB (30 Hz – 15 kHz)
TUNER, CD, AUX, TAPE 1, TAPE 2/DCC	3 Hz – 80 kHz (+0, –3 dB) +0 dB, –0.3 dB (20 Hz – 20 kHz)

Tone controls

BASS	50 Hz, +10 to –10 dB
TREBLE	20 kHz, +10 to –10 dB
Output voltage	
TAPE 1, TAPE 2/DCC REC OUT	150 mV
Channel balance (AUX 250 Hz – 6.3 kHz)	±1 dB
Channel separation (AUX 1 kHz)	50 dB

GENERAL

Power consumption	315 W
Power supply	
For (E) and (EG) areas	50 Hz/60 Hz AC, 230 V
For (EB) and (GN) areas	50 Hz/60 Hz AC, 230 V – 240 V
For (GC) area only	50 Hz/60 Hz AC, 110 V – 127 V / 220 V – 240V
Dimensions (W × H × D)	430 × 136 × 365 mm
Weight	9.4 kg

Notes:

- Specifications are subject to change without notice. Weight and dimensions are approximate.
- Total harmonic distortion is measured by the digital spectrum analyzer.
- For areas except Europe
The specification values given have been measured while using a 240 V power supply.

For (EB) area only

This apparatus was produced to BS 800.

Technics

■ Contents

	Page		Page
● Before Repair	2	● Schematic Diagram	14~20
● Protection Circuitry	2	● Printed Circuit Board Diagram	21~25
● Accessories	2	● Wiring Connection Diagram	26
● Caution for Mains Lead	3	● Block Diagram	27
● Front Panel Controls	4	● Function of IC Terminals	28
● Connections	5, 6	● Replacement Parts List	29~35
● Listening to Sound	7, 8	● Cabinet Parts Location	33, 34
● Recording	9	● Packaging	35
● Operation Check and Main Component Replacement Procedures	10~13		

■ Before Repair

- (1) Turn off the power supply. Using a 10 Ω, 10 W resistor, connect both ends of power supply capacitors (C701, C702) in order to discharge the voltage.
 (2) Before turning the power supply on, after completion of repair, slowly apply the primary voltage by using a power supply voltage controller to make sure that the consumed current at 50/60 Hz in NO SIGNAL mode should be shown below with respect to supply voltage 110 V/127 V/220 V/240 V.

Power supply voltage	AC 230 V	AC 240 V	AC 110~127 V	AC 220~240 V
Consumed current 50Hz	70~270 mA	60~260 mA	120~500 mA	60~260 mA

■ Protection circuitry

The protection circuitry may have operated if either of the following conditions is noticed:

- * No sound is heard when the power is switched ON.
- * Sound stops during a performance.

The functions of this circuitry is to prevent circuitry damage if, for example, the positive and negative speaker connection wires are "shorted", or if speaker systems with an impedance less than the indicated rated impedance of this unit are used.

If this occurs, follow the procedure outlined below:

1. Switch OFF the power.
2. Determine the cause of the problem and correct it.
3. Switch ON the power once again.

Note:

When the protection circuitry functions, the unit will not operate unless the power is first switched OFF and then ON again.

For areas except (E) (EB) (EG) (GN)

CAUTION:

The AC voltage differs according to the area.
 Be sure to set the proper voltage in your area before use.

■ Accessories

- AC power supply cord

for (E), (EG) and (GC) areas : (RJA0019-2K)

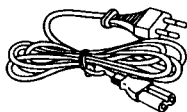

for (EB) area : (VJA0733)

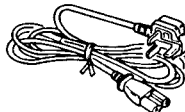

for (GN) area : (RJA0036-K)

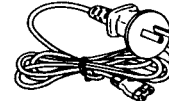

- Remote control transmitter
(RAK-SU129WH)

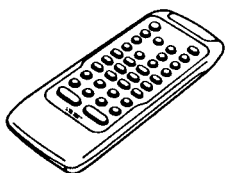

- Batteries
(UM-4, "AAA", R03)

Note: These are available on sales route.



- Power plug adaptor
(SJP5213-2)

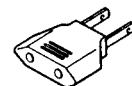

for (GC) area only



■ Caution for AC Mains Lead (For United Kingdom)

("EB" area code model only)

For your safety, please read the following text carefully.

This appliance is supplied with a moulded three pin mains plug for your safety and convenience. A 5-ampere fuse is fitted in this plug. Should the fuse need to be replaced please ensure that the replacement fuse has a rating of 5-ampere and that it is approved by ASTA or BSI to BS1362. Check for the ASTA mark  or the BSI mark  on the body of the fuse.

If the plug contains a removable fuse cover you must ensure that it is refitted when the fuse is replaced.

If you lose the fuse cover the plug must not be used until a replacement cover is obtained.

A replacement fuse cover can be purchased from your local dealer.

CAUTION!

IF THE FITTED MOULDED PLUG IS UNSUITABLE FOR THE SOCKET OUTLET IN YOUR HOME THEN THE FUSE SHOULD BE REMOVED AND THE PLUG CUT OFF AND DISPOSED OF SAFELY.

THERE IS A DANGER OF SEVERE ELECTRICAL SHOCK IF THE CUT OFF PLUG IS INSERTED INTO ANY 13-AMPERE SOCKET.

If a new plug is to be fitted please observe the wiring code as shown below.

If in any doubt please consult a qualified electrician.

IMPORTANT

The wires in this mains lead are coloured in accordance with the following code:

Blue: Neutral

Brown: Live

As the colours of the wires in the mains lead of this appliance may not correspond with the coloured markings identifying the terminals in your plug, proceed as follows:

The wire which is coloured BLUE must be connected to the terminal in the plug which is marked with the letter N or coloured BLACK.

The wire which is coloured BROWN must be connected to the terminal in the plug which is marked with the letter L or coloured RED.

Under no circumstances should either of these wires be connected to the earth terminal of the three pin plug, marked with the letter E or the Earth Symbol .

Before use

Remove the connector cover as follows.

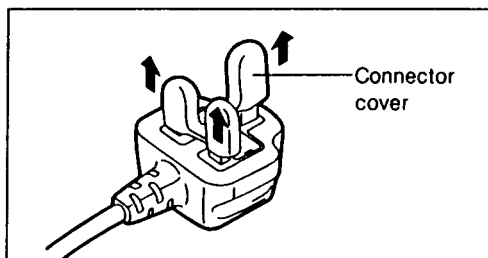

How to replace the fuse

1. Remove the fuse cover with a screwdriver.

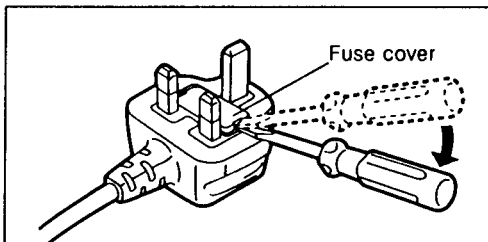

2. Replace the fuse and attach the fuse cover.

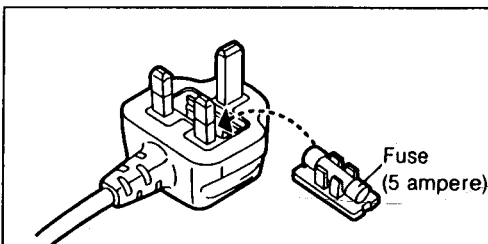

■ Front Panel Controls

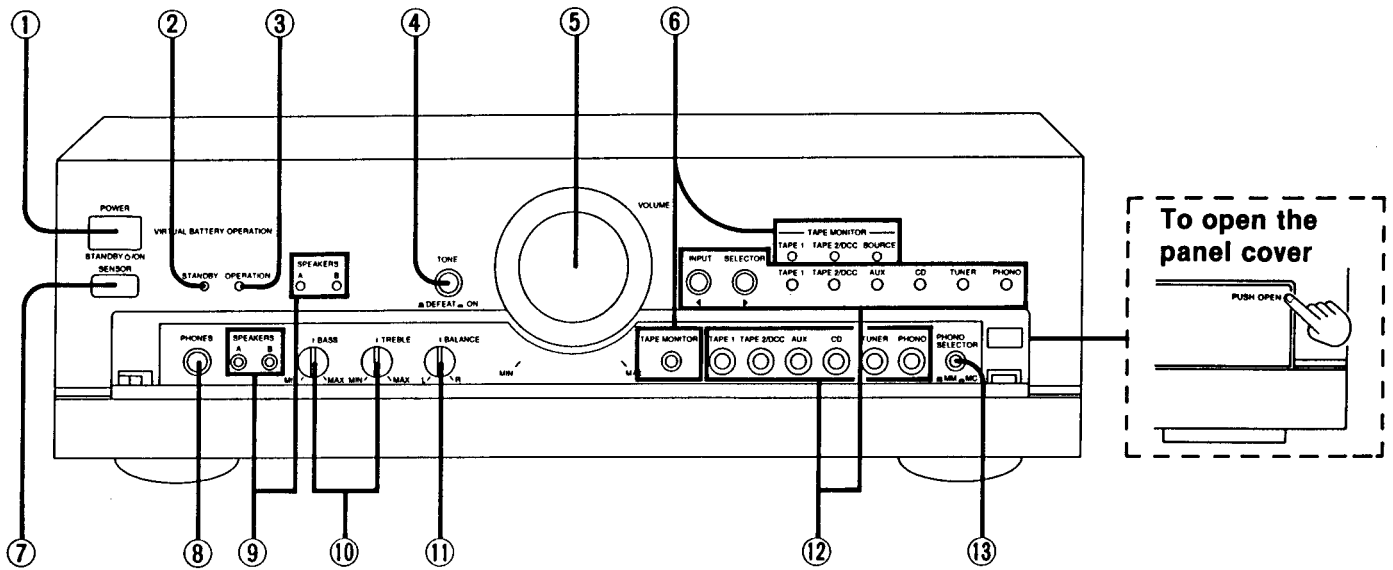

No.	Name
①	Power "STANDBY ON" switch (POWER, STANDBY ON) Press to switch the unit from on to standby mode or vice versa. In standby mode, the unit is still consuming a small amount of power.
②	"STANDBY" indicator (STANDBY) When the unit is connected to the AC mains supply, this indicator lights up in standby mode and goes out when the unit is turned on.
③	Operation indicator (OPERATION) When the power is switched ON, this indicator illuminates after about 4 seconds when the unit is in the operating condition. If an abnormal condition in the circuitry is detected, such as DC voltage appearing in the output or a short-circuit of the positive (+) and negative (-) wires from the speaker terminals, the protection circuit functions and this indicator will not illuminate.
④	Tone control button (TONE)
⑤	Volume control (VOLUME)
⑥	Tape-monitor button/indicators (TAPE MONITOR)

No.	Name
⑦	Remote control signal receptor (SENSOR) Receives the signals from the remote control.
⑧	Headphones jack (PHONES)
⑨	Speaker select buttons/indicators (SPEAKERS)
⑩	Tone controls (BASS/TREBLE)
⑪	Balance control (BALANCE)
⑫	Input select buttons/indicators (INPUT SELECTOR)
⑬	Phono cartridge selector (PHONO SELECTOR)

■ Connections

To connect to each terminal

Make connections to each component in the system by using stereo connection cables (not included).

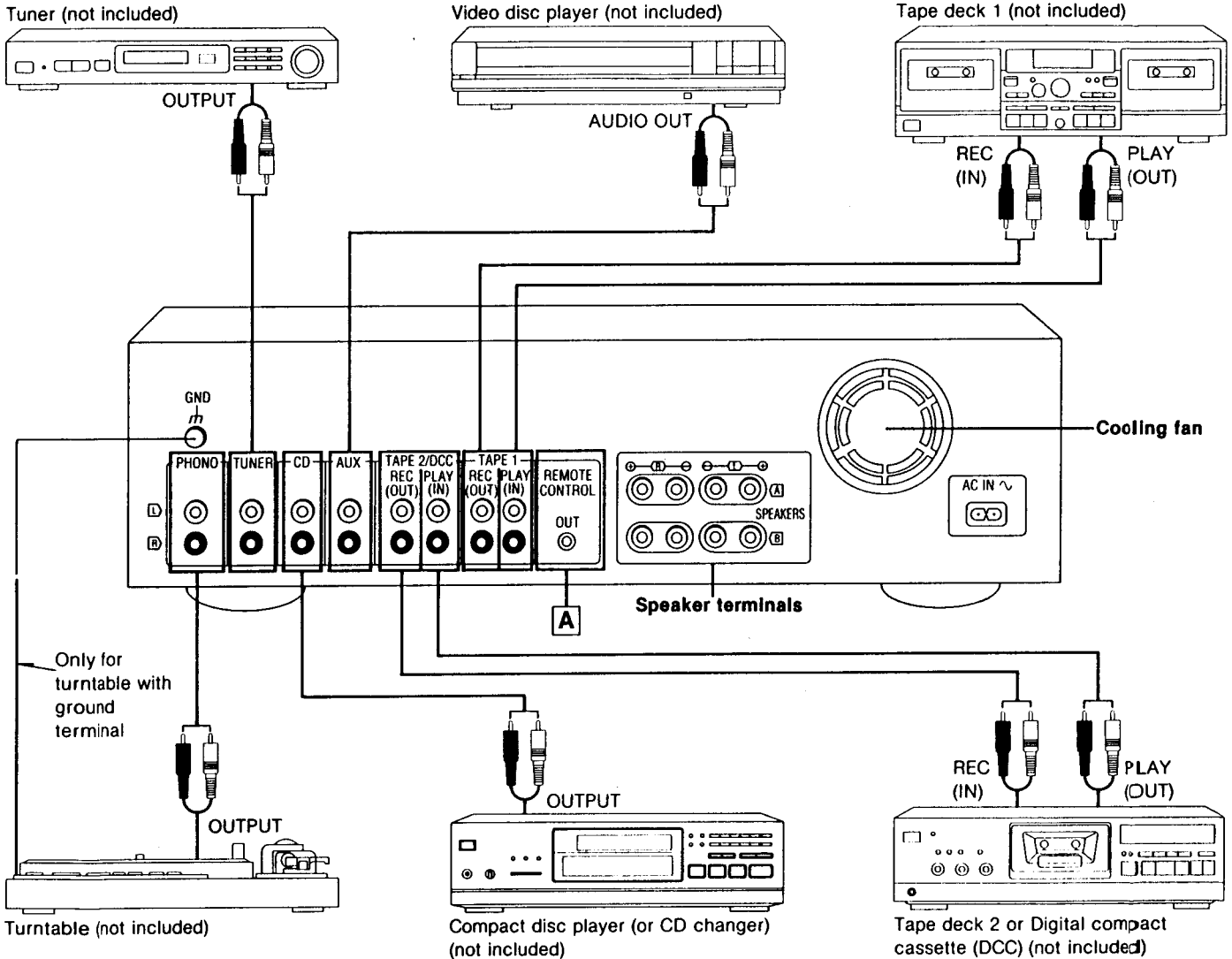
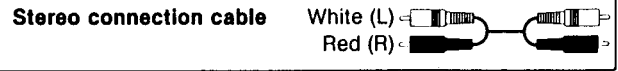

A "REMOTE CONTROL OUT" terminal

Connect the connection cable for the remote control to a Technics tape deck and/or CD player (or CD changer) which has the appropriate remote control terminal as shown at the right.

If a tape deck is not being used, the CD player (or CD changer) can be connected directly (dotted line).

Note

For a tape deck and/or CD player (or CD changer) with a remote control sensor, this connection is not necessary.

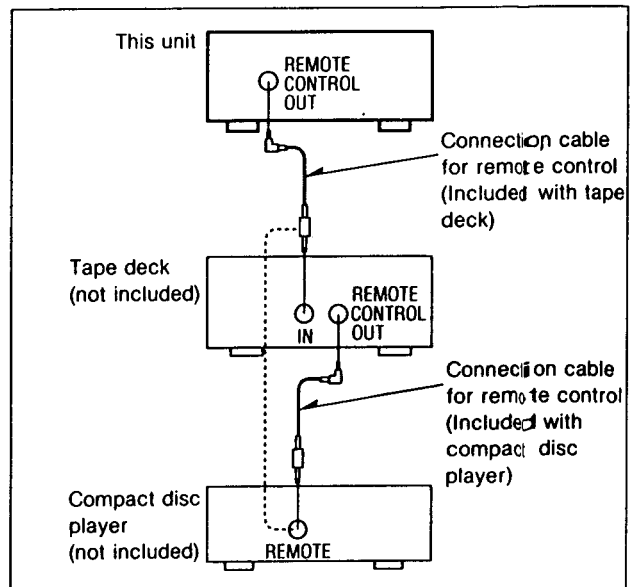

To connect the speakers

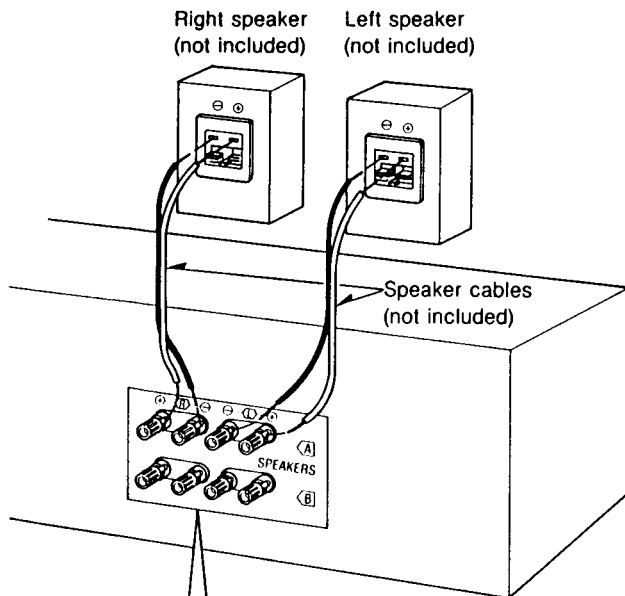

① Strip off the outer covering, and twist the center conductor.

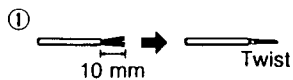

② Turn completely to the left.

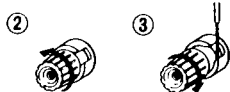

③ Insert the wire and turn completely to the right. Pull the cord to assure a proper connection.

Note Be sure to only connect positive (+) cords to positive (+) terminals, and negative (-) cords to negative (-) terminals.

Note

To prevent damage to circuitry, never short-circuit the positive (+) and negative (-) speaker wires.

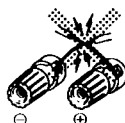

■ "B" terminals

For connection to a second pair of speakers.

■ Speaker impedance

- When only the "A" or only the "B" terminals are used: 4–16 ohms
- When both the "A" and the "B" terminals are used simultaneously: 8–16 ohms

About the cooling fan

The cooling fan operates at high power output levels only.

To connect the AC power supply cord

FOR UNITED KINGDOM ONLY
BE SURE TO READ THE CAUTION FOR THE AC POWER SUPPLY CORD ON PAGE 3 BEFORE CONNECTING THE AC POWER SUPPLY CORD.

For areas except United Kingdom, Europe, Australia and N.Z.

Be sure to set the voltage selector to "110 V–127 V" or "220 V–240 V" according to the area in which the unit will be used. [Use a minus (-) screwdriver]

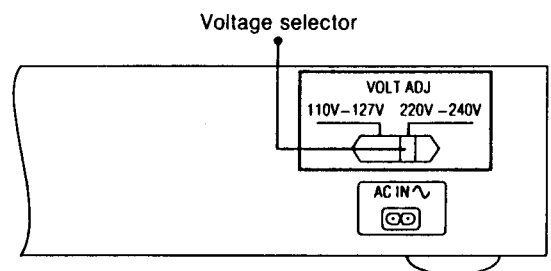

Note

Note that this unit will be seriously damaged if this setting is not made correctly.

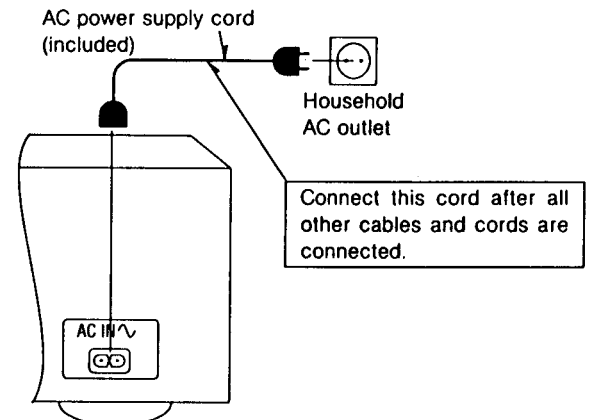

Note

The configuration of the AC power supply cord differs according to area.

(For areas except Australia and N.Z.)

Insertion of Connector

Even when the connector is perfectly inserted, depending on the type of inlet used, the front part of the connector may jut out as shown in the drawing.

However there is no problem using the unit.

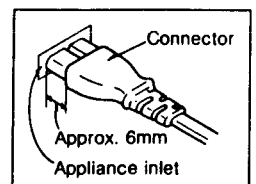

Not supplied for United Kingdom, Europe, Australia and N.Z.

If the power plug will not fit your socket, use the power plug adaptor (included).

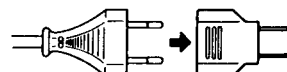

■ Listening to Sound

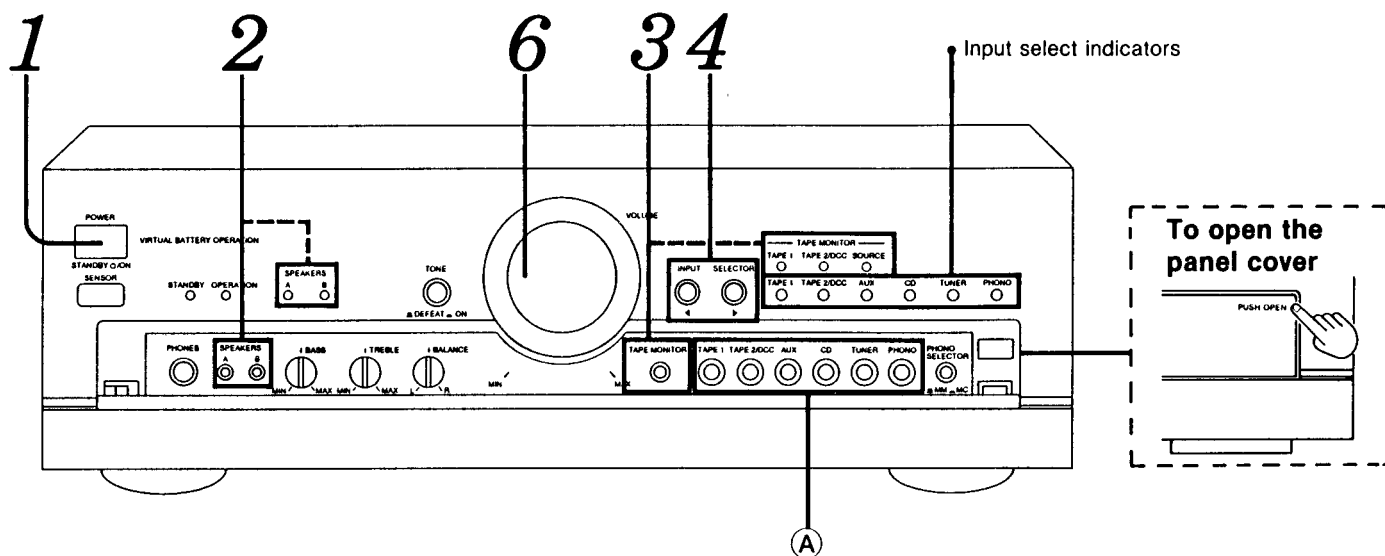

Before operation, set VOLUME to the "MIN" position.

1 **POWER** Press **POWER** to switch on the power.

2 **SPEAKERS A B** Press **A** and/or **B** to select the speaker system(s) to be used.

A and B refer to the speaker terminals at the rear of the unit.

The corresponding indicator above will illuminate to indicate which speaker system is selected.

A: Sound can be heard from the speakers connected to the "A" terminals.

B: Sound can be heard from the speakers connected to the "B" terminals.

A and B: Sound can be heard simultaneously from the speakers connected to the "A" terminals and the "B" terminals.

off: No sound will be heard from the speakers. (Both indicators will turn off.)

3 **TAPE MONITOR** Press **TAPE MONITOR** so that the "SOURCE" indicator illuminates.

Note

When a graphic equalizer is connected to the "TAPE 1" or "TAPE 2/DCC" terminals, press the button so that the "TAPE 1" or "TAPE 2/DCC" indicator illuminates.

4 Press ◀ or ▶ to select the sound source.

◯ : Each time the button is pressed, the illuminated position of the input select indicator will shift one position to the left.

◯ : Each time the button is pressed, the illuminated position of the input select indicator will shift one position to the right.

To directly select the input source

The desired input source can be selected directly by using the input select buttons (A) located inside the panel.

TAPE 1: Set to this position to listen to equipment connected to the "TAPE 1" terminals.

TAPE 2/DCC: Set to this position to listen to equipment connected to the "TAPE 2/DCC" terminals.

AUX: Set to this position to listen to equipment connected to the "AUX" terminals.

CD: Set to this position to listen to compact discs.

TUNER: Set to this position to listen to radio broadcasts.

PHONO: Set to this position to listen to phono discs. Then, set the phono cartridge selector to the position which corresponds to the type of cartridge used on the turntable.

5 Start the desired source.

6 Turn **VOLUME** to adjust the volume level.

After listening is finished

Be sure to reduce the volume level, and switch the power to the standby condition by pressing POWER.

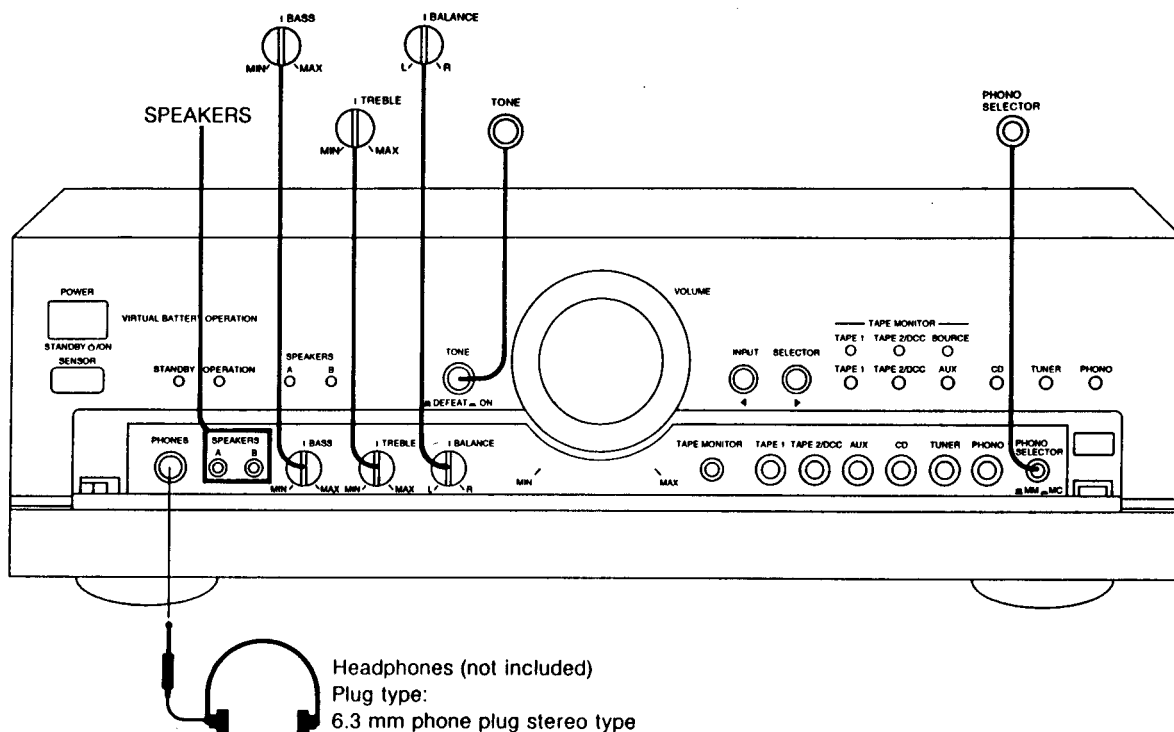

To adjust the tone quality



Set TONE to the "ON" position.
If set to the "DEFEAT" position, tone controls have no effect.

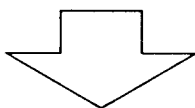

Turn **BASS** to adjust the low-frequency sound.



Turn **TREBLE** to adjust the high-frequency sound.

To adjust the sound balance



Turn **BALANCE** to adjust the left/right sound balance.

When listening phono discs



Select the cartridge type.

MM:
Set to this position when using a moving-magnet type cartridge or high-output moving-coil cartridge (1 mV or more).

MC:
Set to this position when using a moving-coil type cartridge.

When listening through headphones

Use **VOLUME** to reduce the volume level, and connect the headphones.

If sound from speakers is not wanted, press **SPEAKERS (A)** and/or **(B)** to turn off the speaker select indicators.

Note

Avoid listening for prolonged periods of time to prevent hearing damage.

Recording

To record from compact discs, etc.

It is possible to record from units which are connected to the rear "AUX", "CD", "TUNER" or "PHONO" terminals to cassette tape decks or DCC decks which are connected to the "TAPE 1" or "TAPE 2/DCC" terminals.

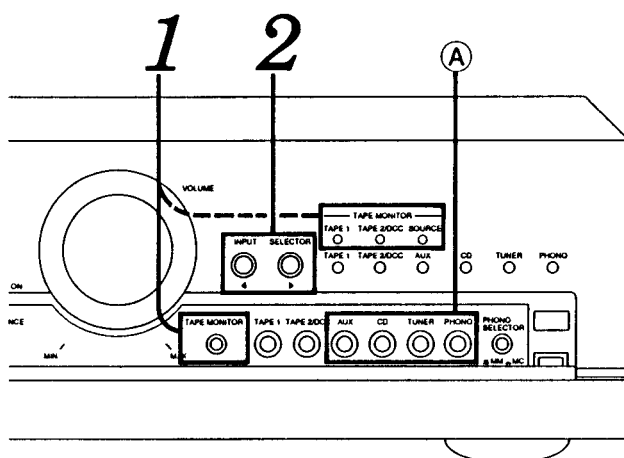

Before recording, prepare the tape deck or DCC for recording (recording level adjustment, etc.). See the tape deck's or DCC's operating instructions for details.

1 Press **TAPE MONITOR** so that the "SOURCE" indicator illuminates.

2 Select the program source to be recorded.

AUX: To record from equipment connected to the "AUX" terminals.

CD: To record from compact discs.

TUNER: To record from radio broadcasts.

PHONO: To record from phono discs.

3 Begin recording. Follow your tape deck's or DCC's operating instructions.

4 Begin the source to be recorded.

To directly select the source for recording

The desired source can be selected directly by using the input select buttons (**A** **B**) located inside the panel.

To check the sound recorded while recording is being made

If a cassette tape deck with 3 heads is connected to the "TAPE 1" or "TAPE 2/DCC" terminals, it is possible to check the sound being recorded onto the tape.

Tape-to-tape recording

It is possible to record from tape deck 1 (the cassette tape deck which is connected to the "TAPE 1" terminals) to tape deck 2 (the cassette tape deck or DCC deck which is connected to the "TAPE 2/DCC" terminals) and vice versa.

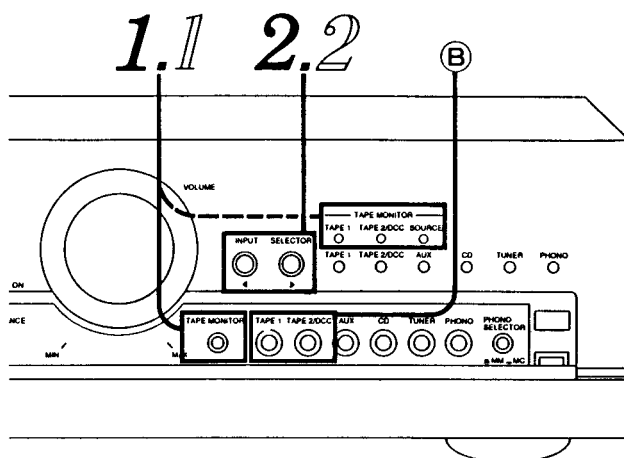

Preparation

- Before recording, prepare the tape deck or DCC for recording (recording level adjustment, etc.). See the tape deck's or DCC's operating instructions for details.
- Load tapes which have been advanced to the end of the leader tape into both decks.

To record from tape deck 2 to 1

1 Press **TAPE MONITOR** so that the "SOURCE" indicator illuminates.

2 Press **◀** or **▶** to select "TAPE 2/DCC".

3 Begin tape deck 1 for recording and tape deck 2 for playback.

To record from tape deck 1 to 2

1 Press **TAPE MONITOR** so that the "SOURCE" indicator illuminates.

2 Press **◀** or **▶** to select "TAPE 1".

3 Begin tape deck 2 for recording and tape deck 1 for playback.

TAPE MONITOR Press **TAPE MONITOR** to select the deck (tape deck 1 or 2) and set the monitor switch on the tape deck to "TAPE".



TAPE 1: when recording on tape deck 1

TAPE 2/DCC: when recording on tape deck 2

■ Operation Check and Main Component Replacement Procedures

NOTE

1. This section describes procedures for checking the operation of the major printed circuit boards and replacing the main components.
2. For reassembly after operation checks or replacement, reverse the respective procedures. Special reassembly procedures are described only when required.
3. Select items from the following index when checks or replacement are required.
4. Illustrated screws are equivalent to actual size.
5. [] indicates parts No.

● Contents

	Page
1. Checking for the Volume P.C.B. /Operation P.C.B. /Tone AMP P.C.B.	11.
2. Checking for the Main P.C.B.	12.
3. Replacement for power IC.	13.

1. Common disassembly procedures (Follow this procedure prior to other disassembly.)

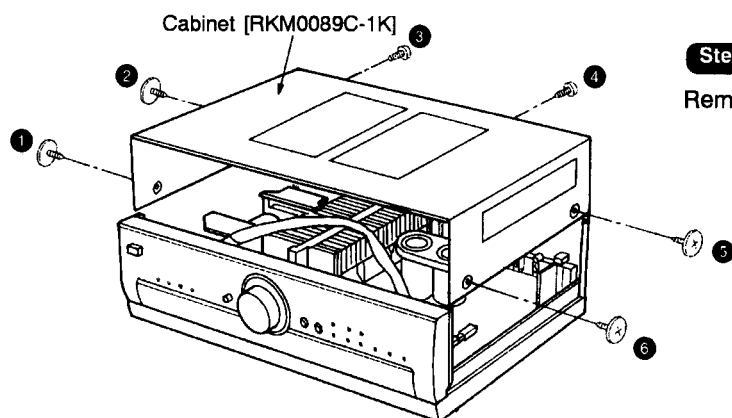

Step 1
Remove the 6 screws.

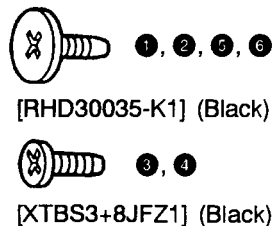

2. Checking for the Volume P.C.B. / Operation P.C.B. /Tone AMP P.C.B.

To check the operation of each P.C.B., use item 1 on page 10.

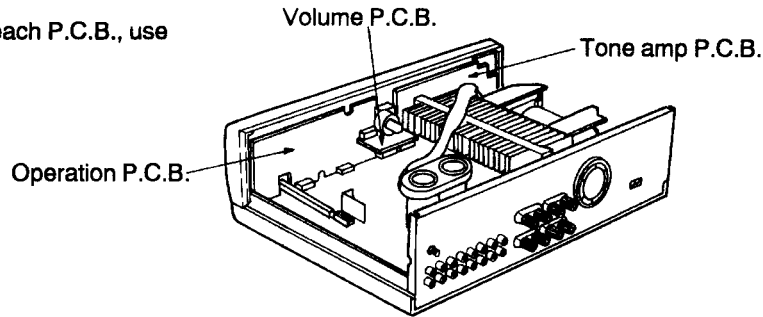

To remove each P.C.B.

Step 1

Remove the 3 screws.

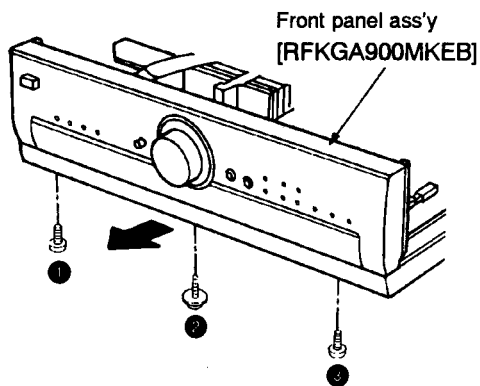

Step 2

Remove the knob and nut.

Step 3

Release the claw, and then remove the volume P.C.B.

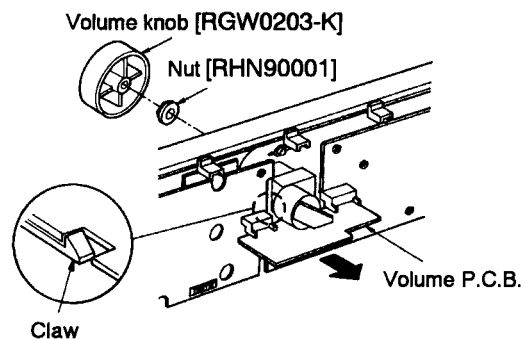

Step 4

Remove the 3 knobs.

Step 5

Remove the 14 screws.

Remove the knob with pushing by ⊖ screwdriver toward the P.C.B. when the knob is hardly removed.

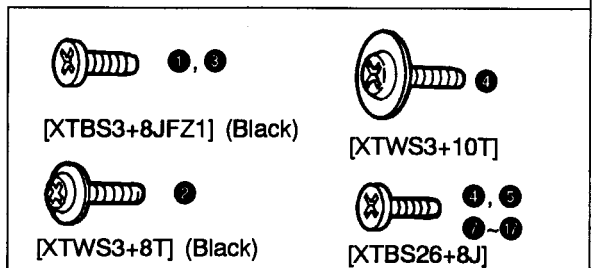
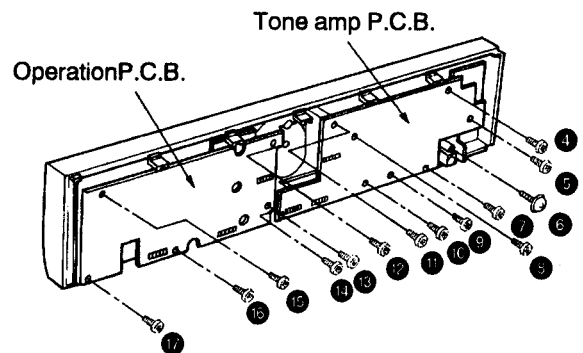
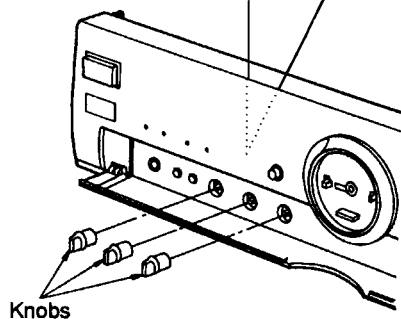

3. Checking for the Main P.C.B.

※ (E, EG) : RGR0171A-EB
 ※ (EB) : RGR0171E-C1C
 ※ (GC) : RGR0171B-CC
 ※ (GN) : RGR0171A-F1C

Step 1 Follow the disassembly procedure described in item 1 on page 10.

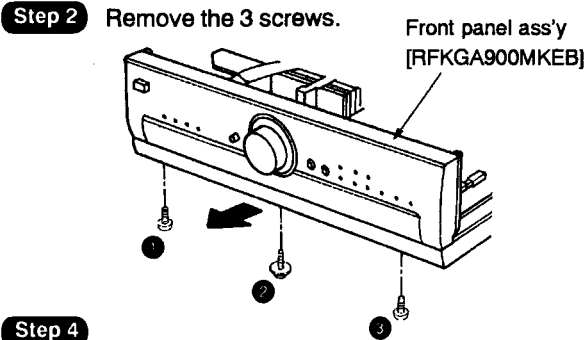

Step 4 Remove the 8 screws.

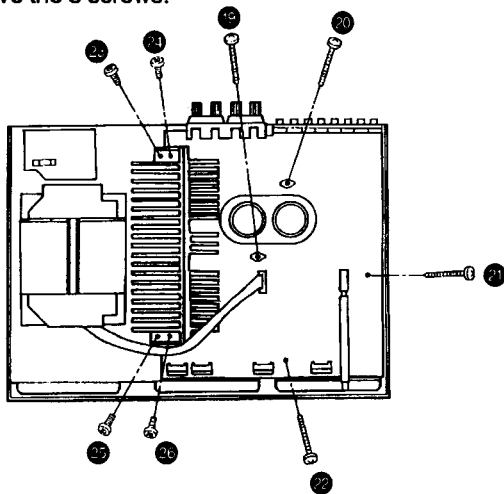

Step 7 Install the rear panel temporarily on the main P.C.B. again.

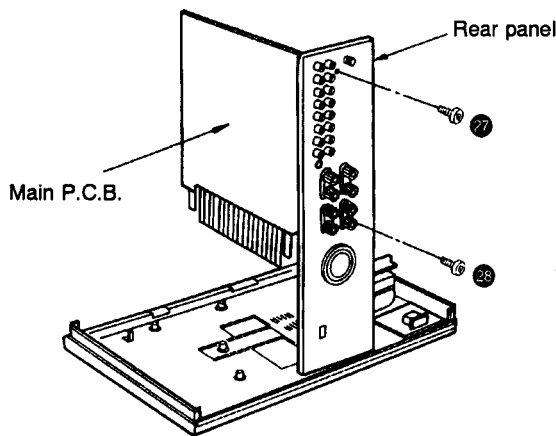

Step 3 Remove the 15 screws and connector.

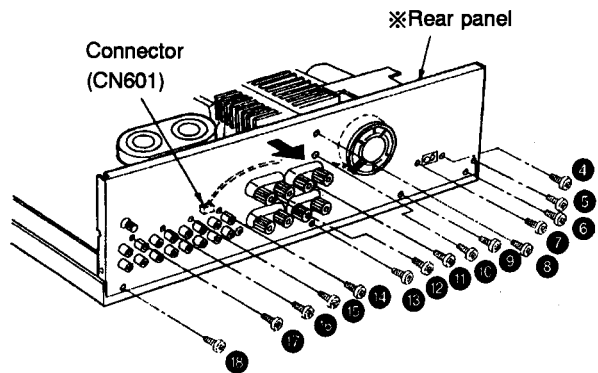

Step 5 Lift the main P.C.B. off the retention post on the bottom chassis.

Step 6 Remove the main P.C.B. in the direction of arrow ①, ②.

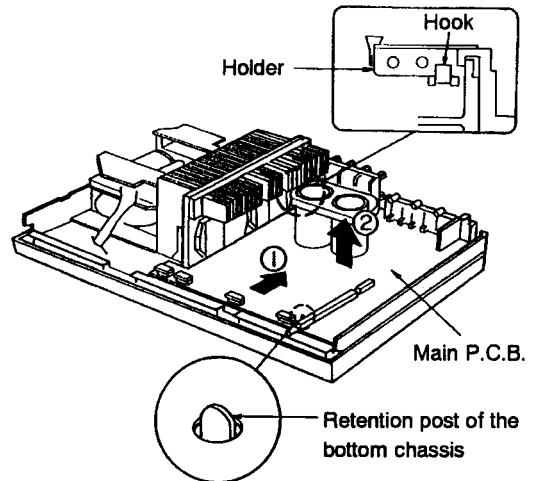

Step 8 Connect the front panel ass'y of the P.C.B. connectors to the main P.C.B. and set it as the illustration below.

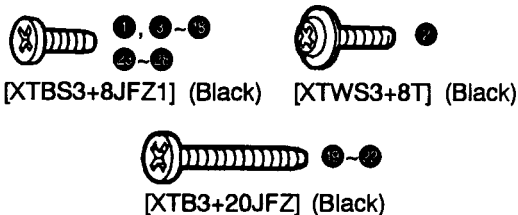
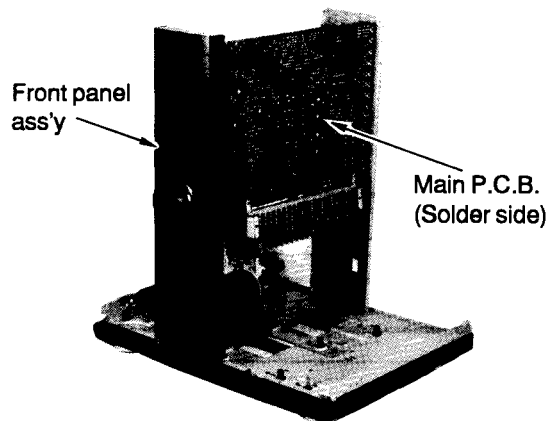

4. Replacement for power IC.

Step 1 Follow the disassembly procedure described in item 1 on page 10.

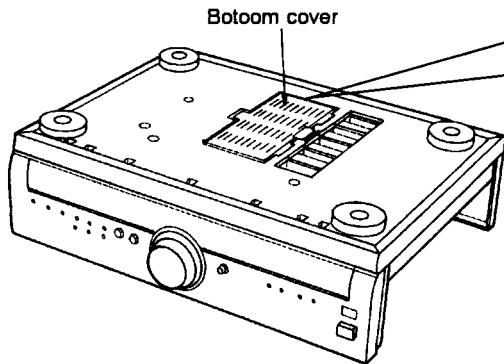

Step 2 When remove the bottom cover, cut the joints (←) as shown below. (9 joints)

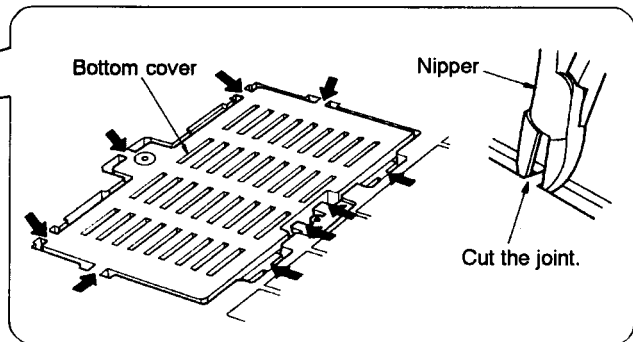

Step 3 Remove the solder of power IC.

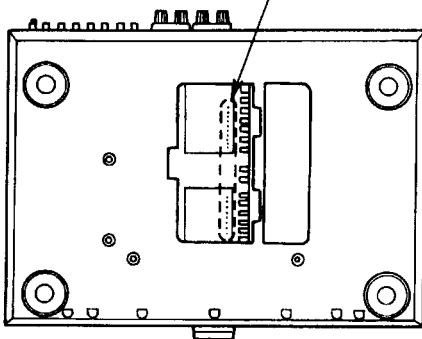

Step 4 Remove the 3 screws, and then remove the sub heat sink and angle.

Step 5 Remove the 4 screws and then remove the power IC's.

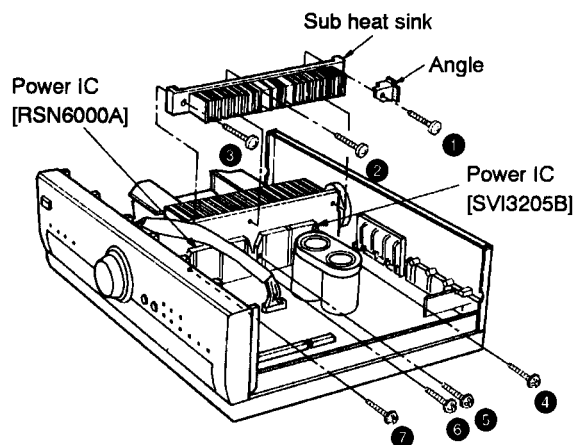

Step 6 Fix the bottom cover with screw.

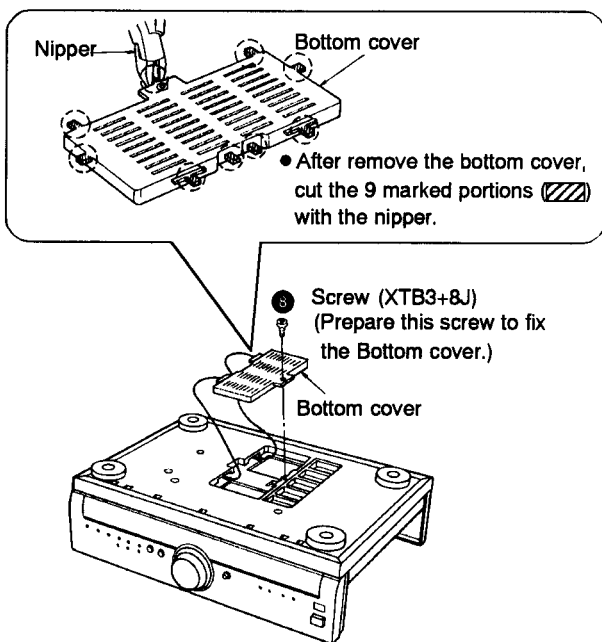

CAUTION

- After replacing the power IC, apply a sufficient quantity of compound grease (RFKX0002/SZZ0L15) between the heat sink and the power IC (Radiation of power IC).
- Tighten enough the screws (①~⑦) after replacing the power IC. Otherwise, the heat radiation works little.

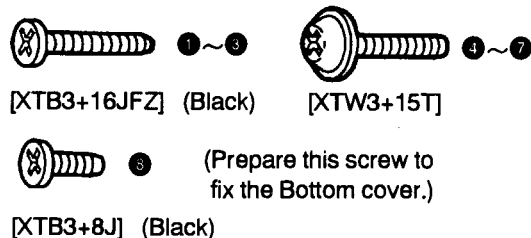

Schematic Diagram • Main/Operation/Switch/Volume/Tone Amp. Circuit (Parts list on page 29~32.)

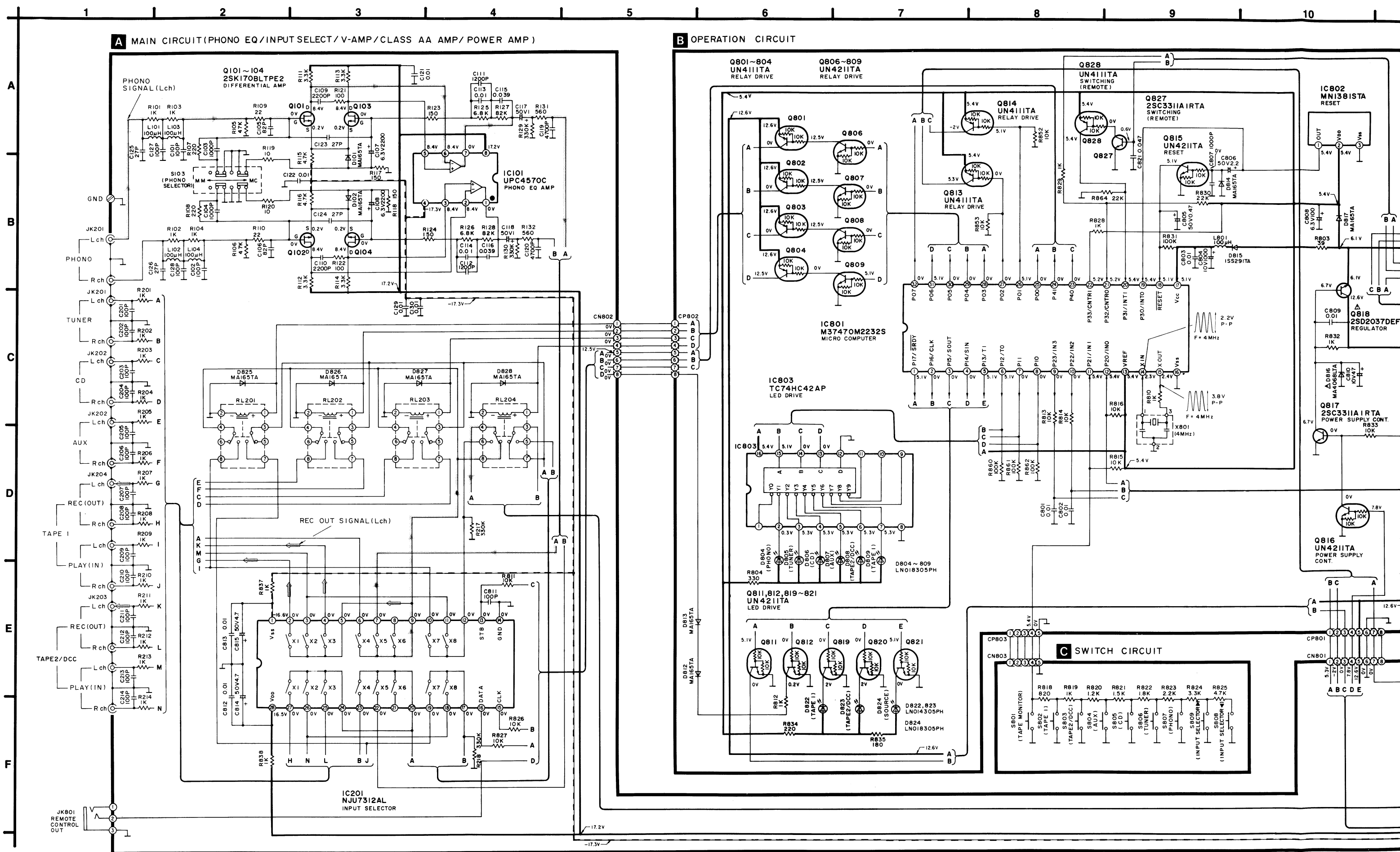

(Parts list on page 29~32.)

5 6 7 8 9 10 11 12 13 14 15

B OPERATION CIRCUIT

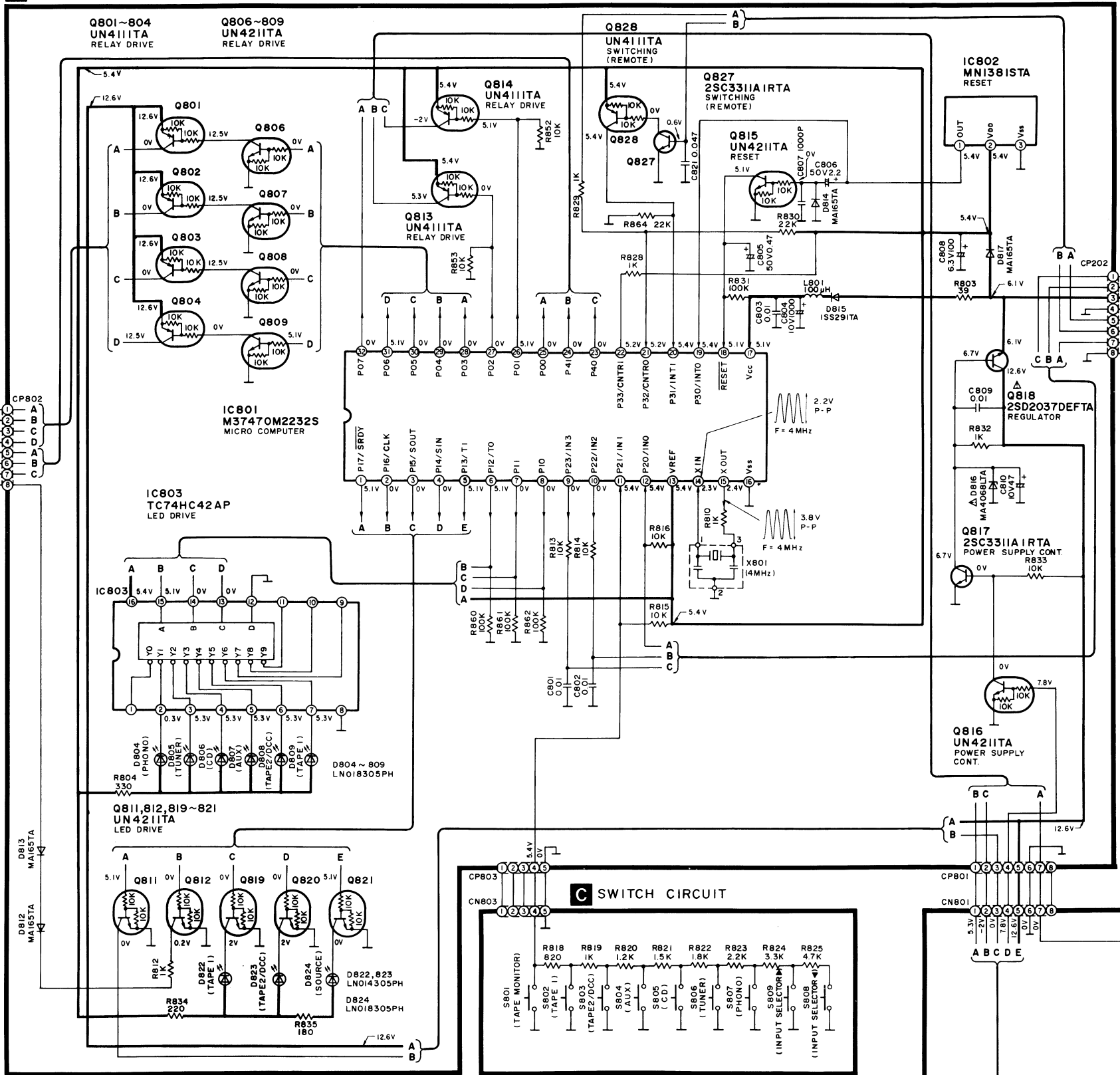

D VOLUME CIRCUIT

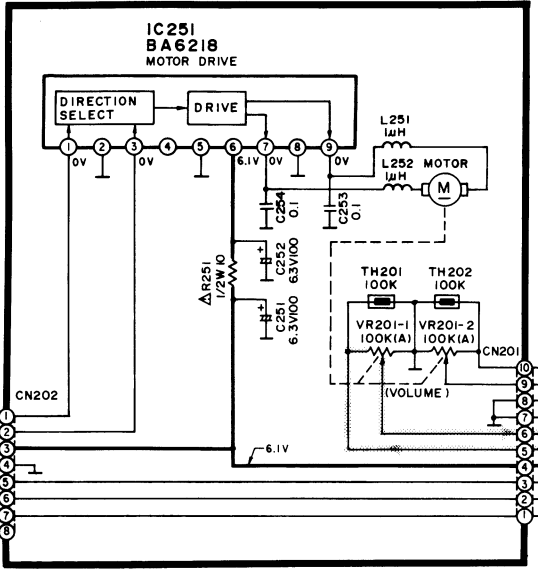

E TONE AMP CIRCUIT

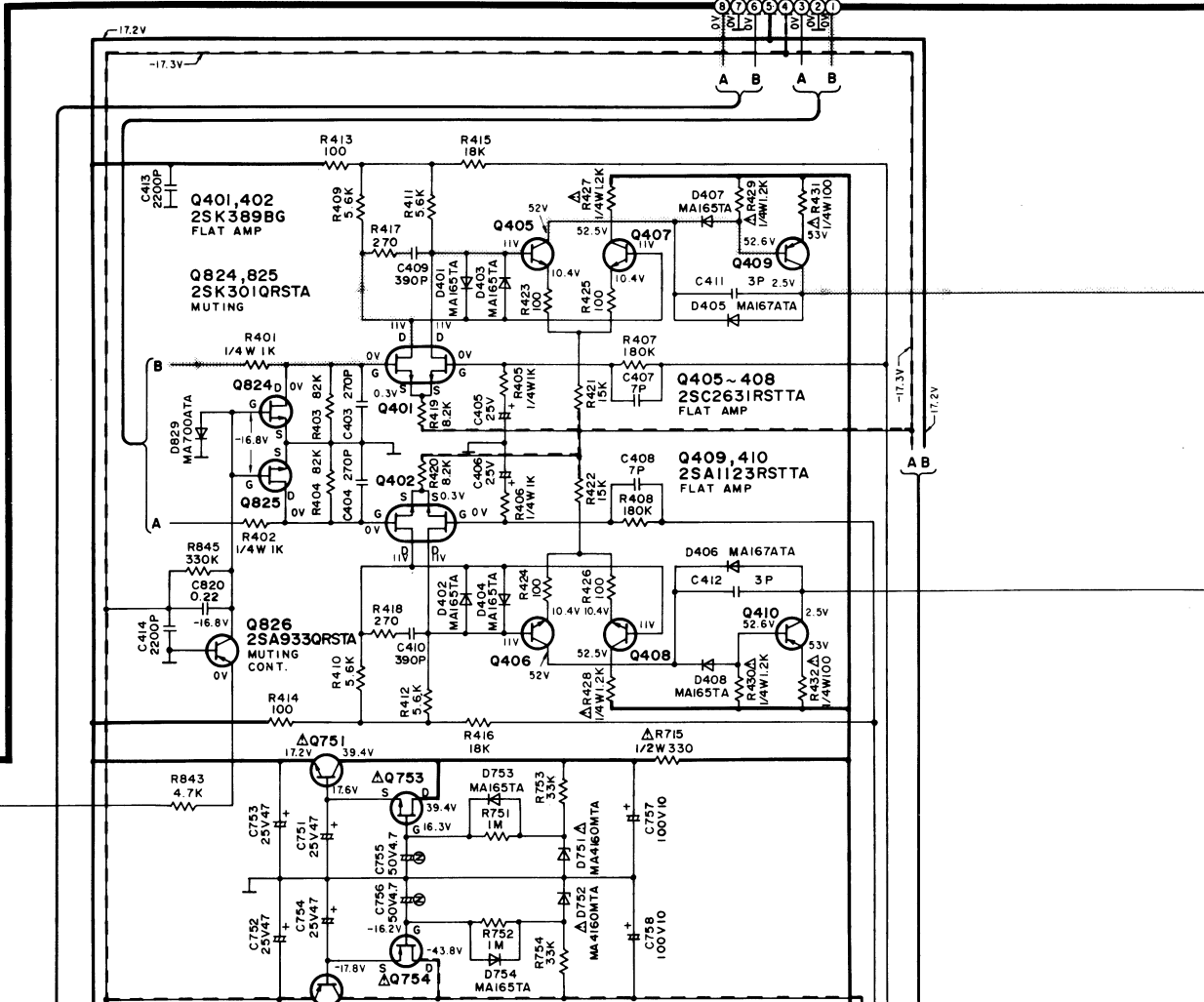
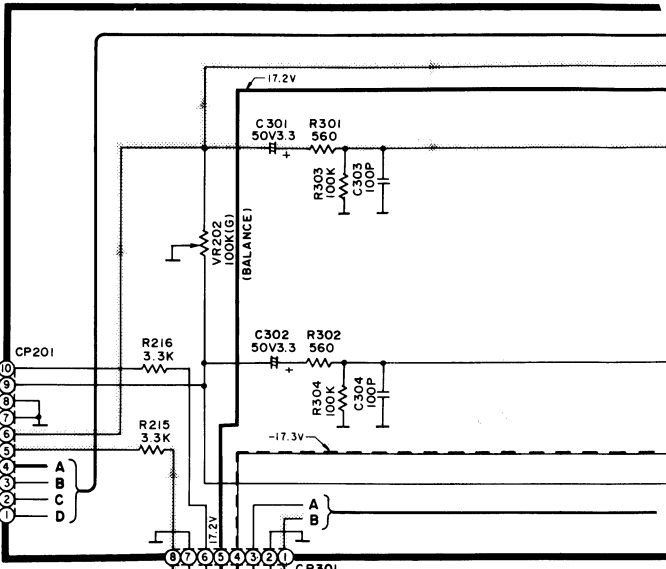

C SWITCH CIRCUIT

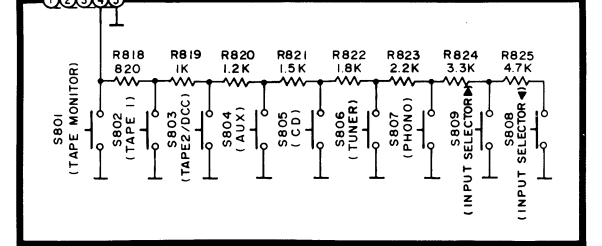

● Power Switch/Headphones Jack/Power Transformer (1) (2)/Power Supply Circuit

(Parts list on page 29~32.)

16 17 18 19 20 21 22 23 24 25 26

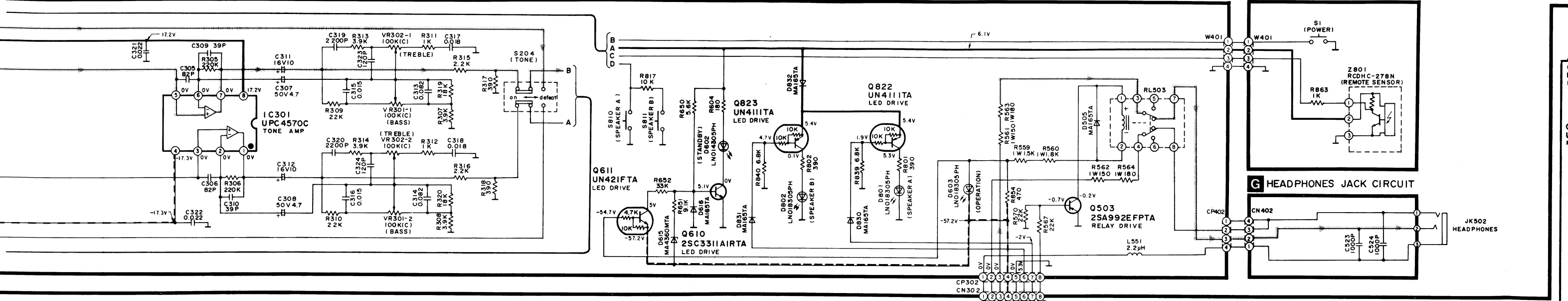

F POWER SWITCH CIRCUIT

G HEADPHONES JACK CIRCUIT

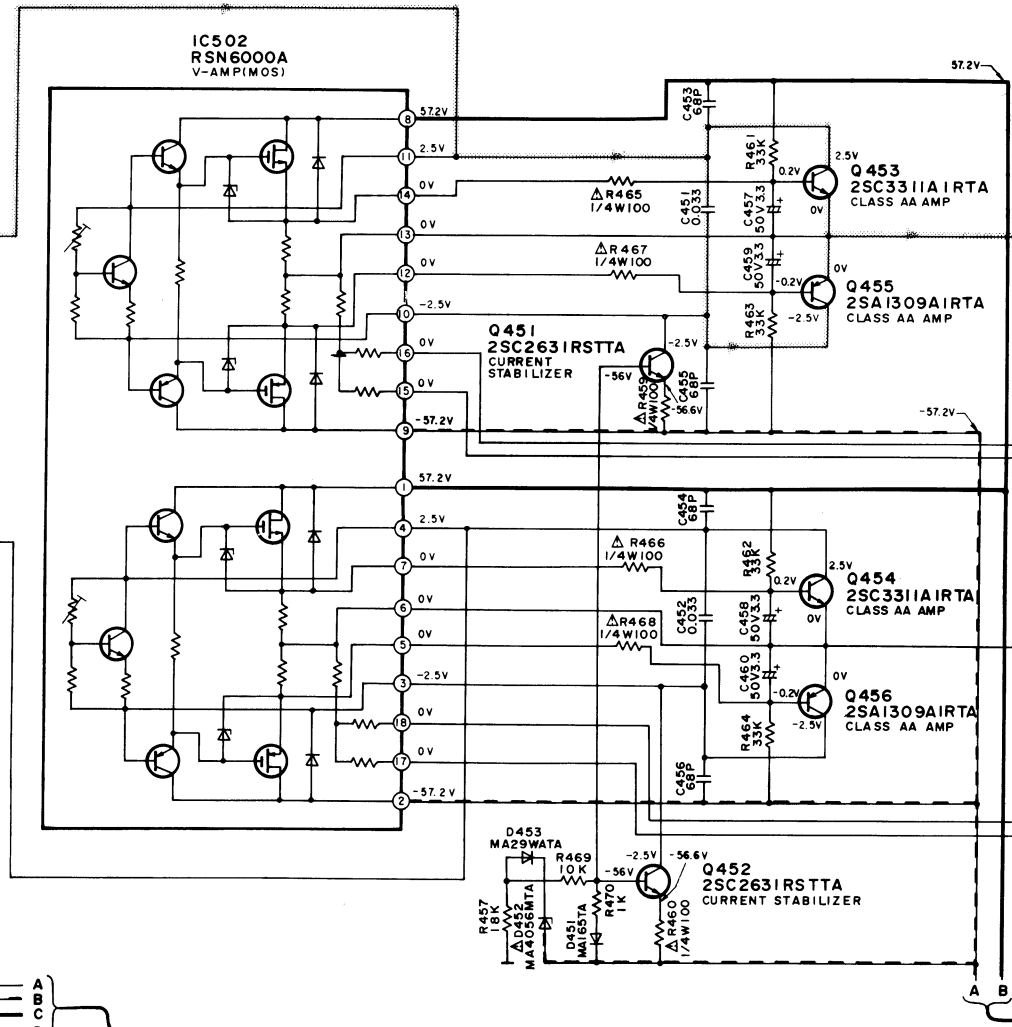

ΔIC501 SVI3205B POWER AMP

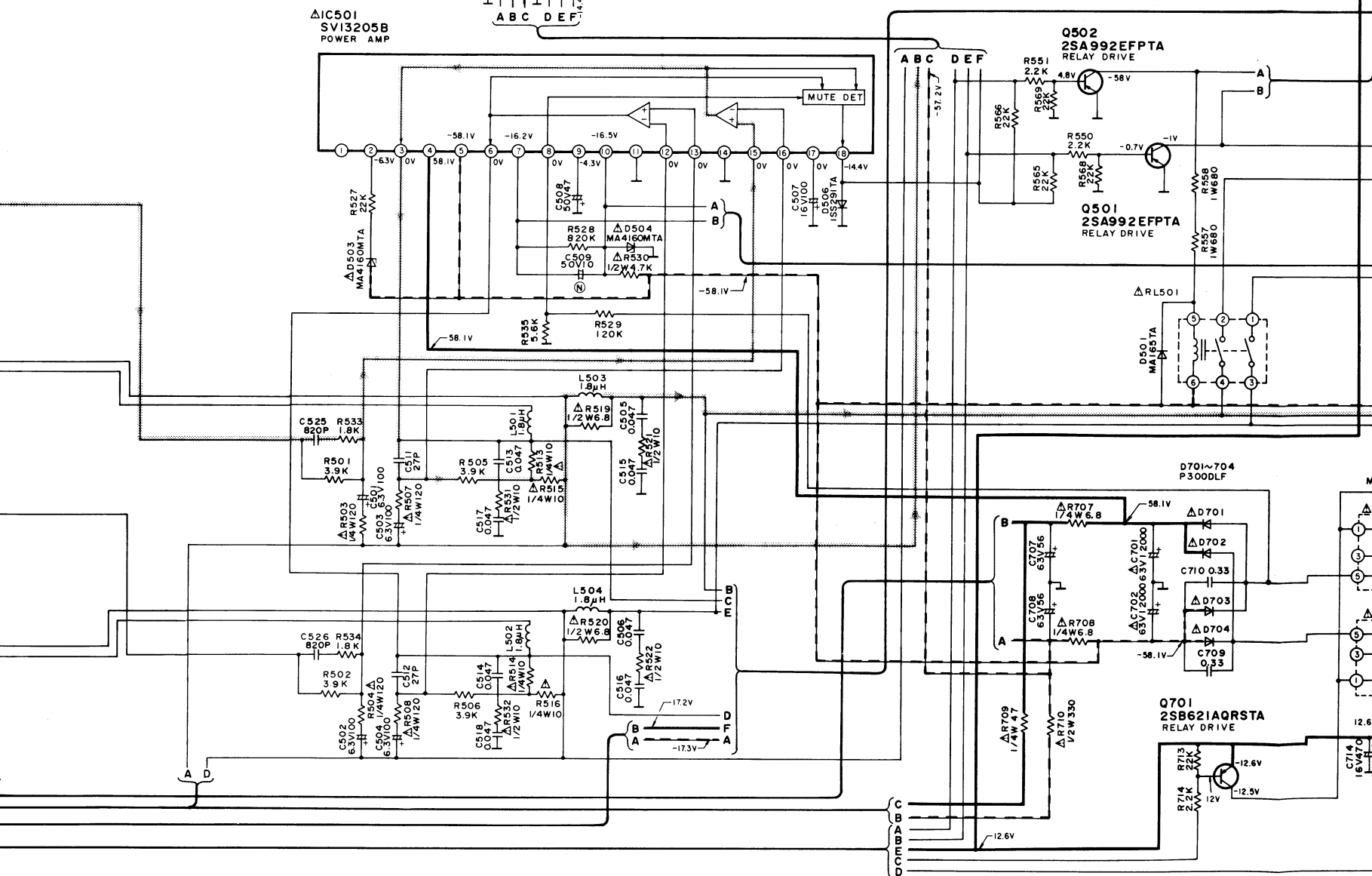

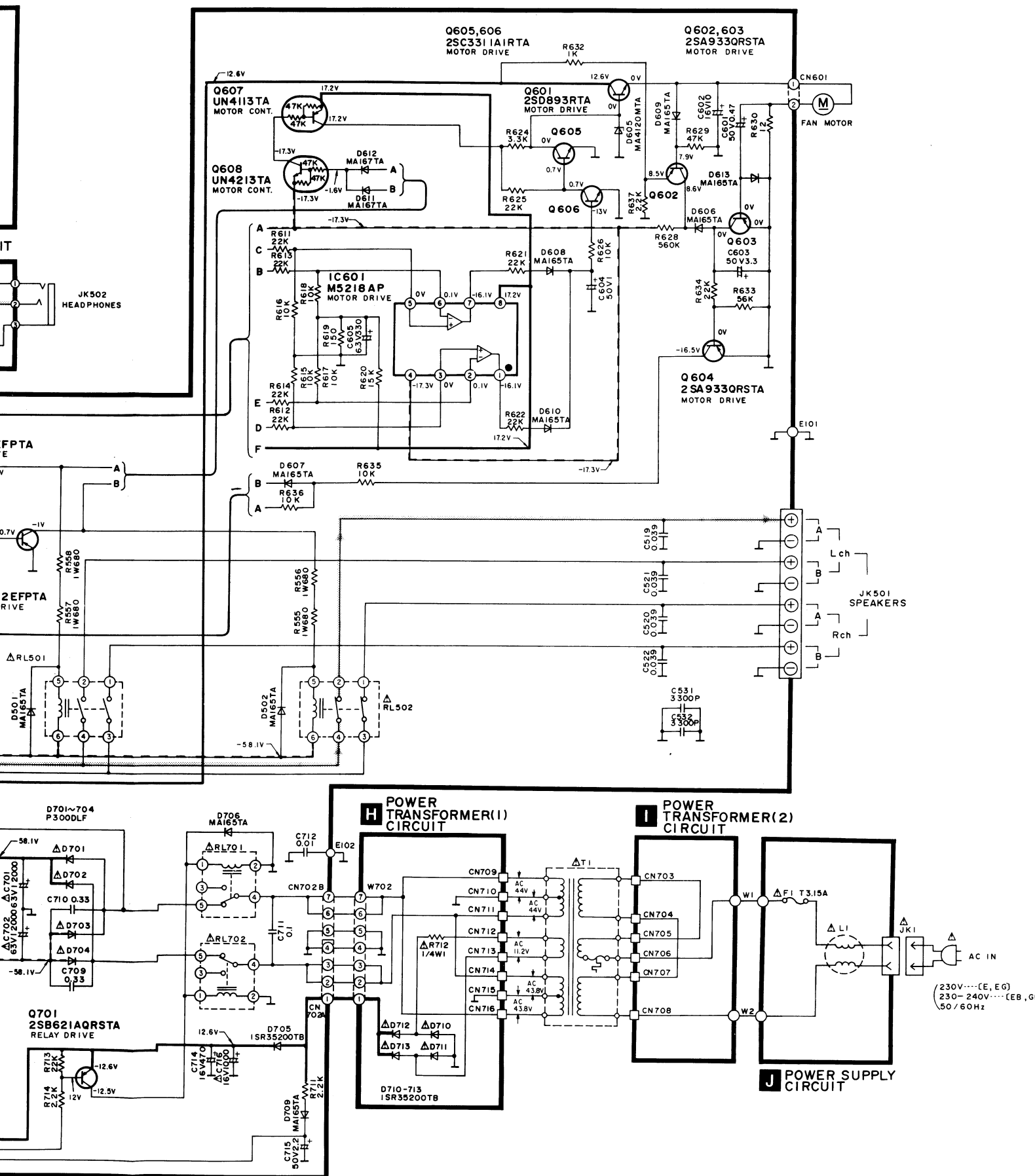

Notes:

- S1 : Power Standby (ON) switch.
- S2 : Voltage select switch in 220 - 240 V position. For (GC) area only.
- S103: Phono cartridge select switch (PHONO SELECTOR).
- S204: TONE control switch (ON/DEFEAT).
- S801: TAPE MONITOR switch.
- S802: Input selector switch (TAPE 1).
- S803: Input selector switch (TAPE 2/DCC).
- S804: Input selector switch (AUX).
- S805: Input selector switch (CD).
- S806: Input selector switch (TUNER).
- S807: Input selector switch (PHONO).
- S808: Input selector switch (◀).
- S809: Input selector switch (▶).
- S810: Speaker select switch (SPEAKER A).
- S811: Speaker select switch (SPEAKER B).

Indicated voltage values are the standard values for the unit measured by the DC electronic circuit tester (high-impedance) with the chassis taken as standard. Therefore, there may exist some errors in the voltage values, depending on the internal impedance of the DC circuit tester. No mark: Power ON

Important safety notice:

Components identified by Δ mark have special characteristics important for safety. Furthermore, special parts which have purposes of fire-retardant (resistors), high-quality sound (capacitors), low-noise (resistors), etc. are used. When replacing any of components, be sure to use only manufacturer's specified parts shown in the parts list.

This schematic diagram may be modified at any time with the development of new technology.

Caution!

IC and LSI are sensitive to static electricity. Secondary trouble can be prevented by taking care during repair. Cover the parts boxes made of plastics with aluminum foil. Ground the soldering iron. Put a conductive mat on the work table. Do not touch the legs of IC or LSI with the fingers directly.

Voltage and signal line

- : Positive voltage line.
- - - : Negative voltage line.
- ▨ : Phono signal line.
- ➔ : Recording output signal line.

The supply part number is described alone in the replacement parts list.

Part No.	Production Part No.	Supply Part No.
Z801	RCDHC-237-E	RCDHC-237

Power Source For (GC) area.

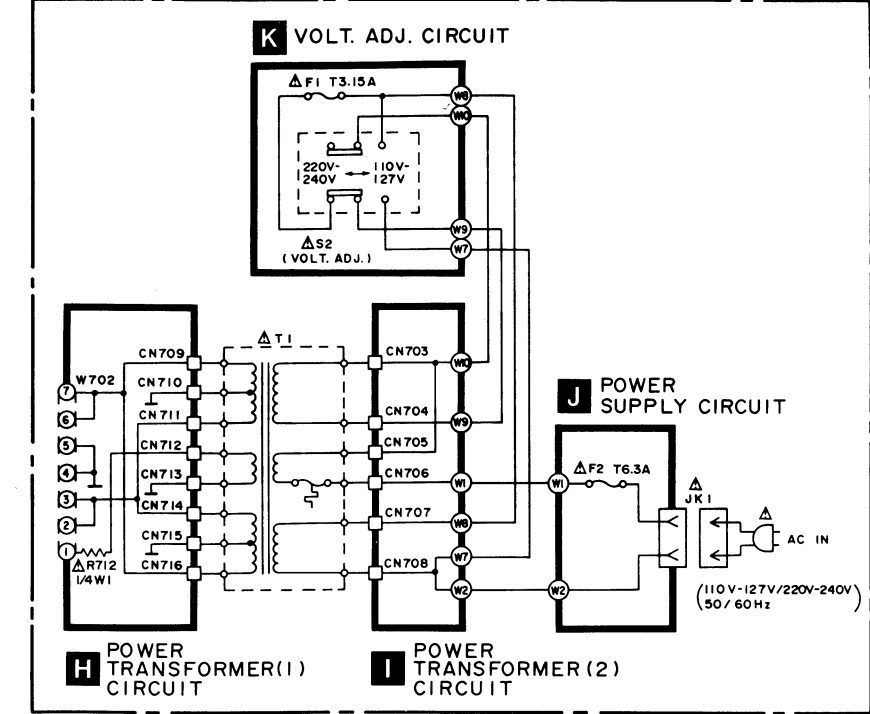

Printed Circuit Board Diagram

This circuit board diagram may be modified at any time with the development of new technology.

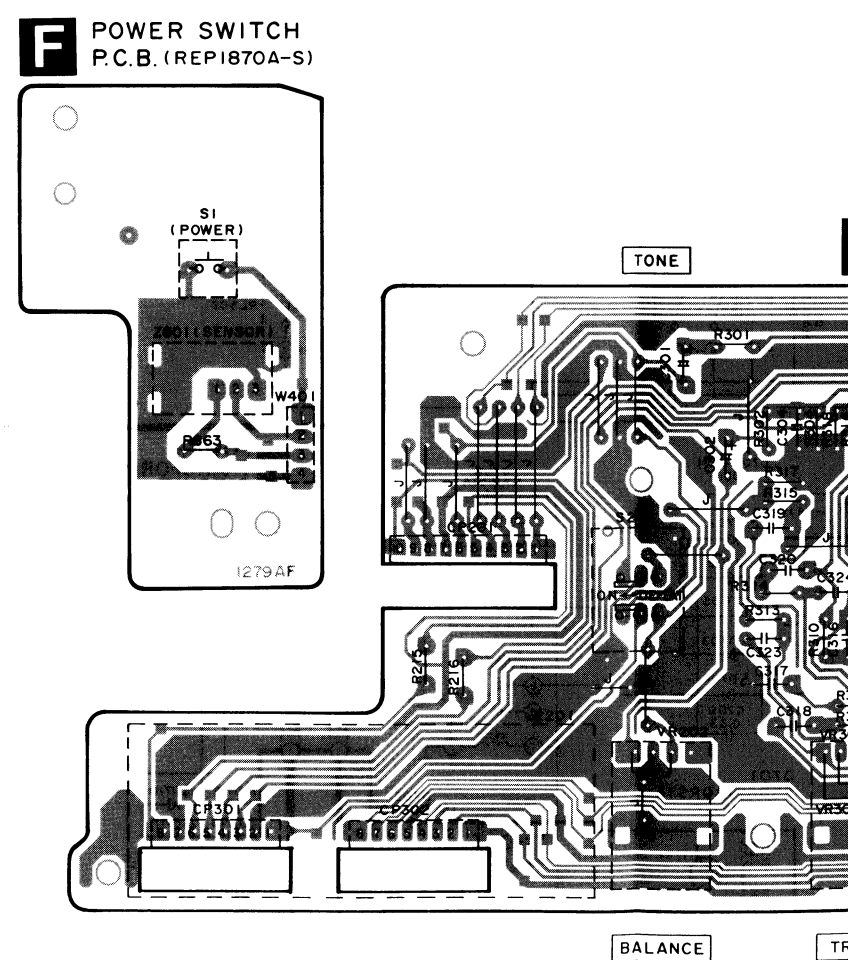
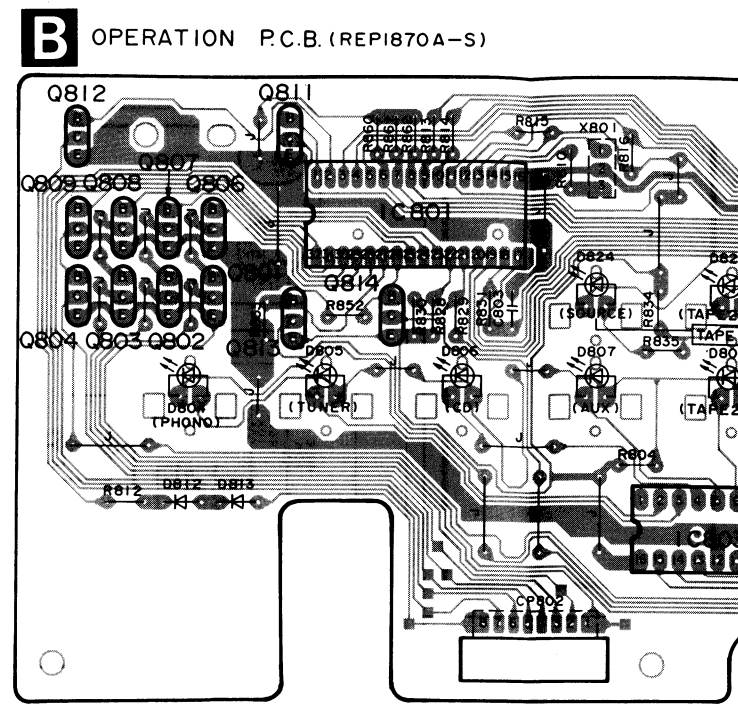
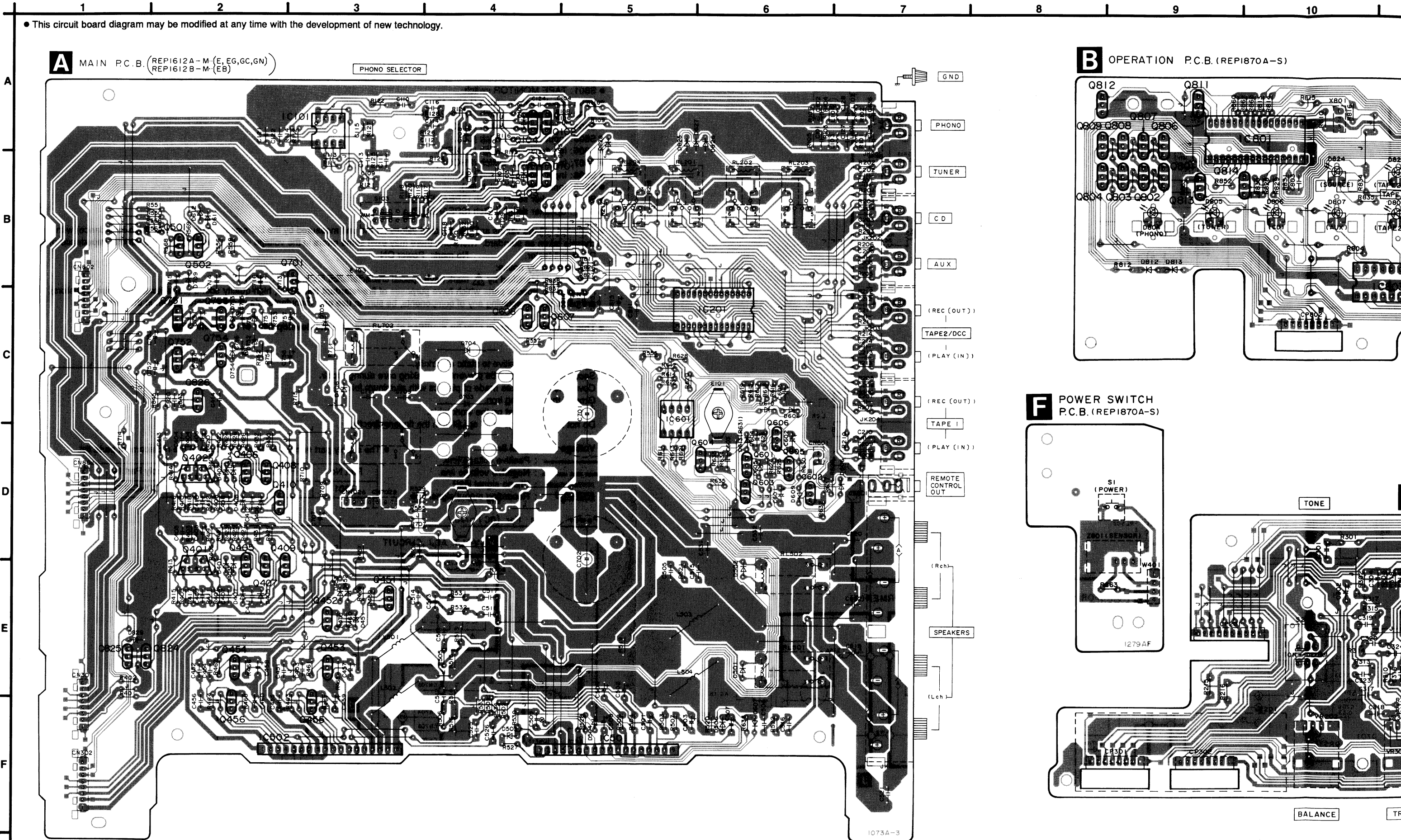

Power Source P.C.B. For (GC) area.

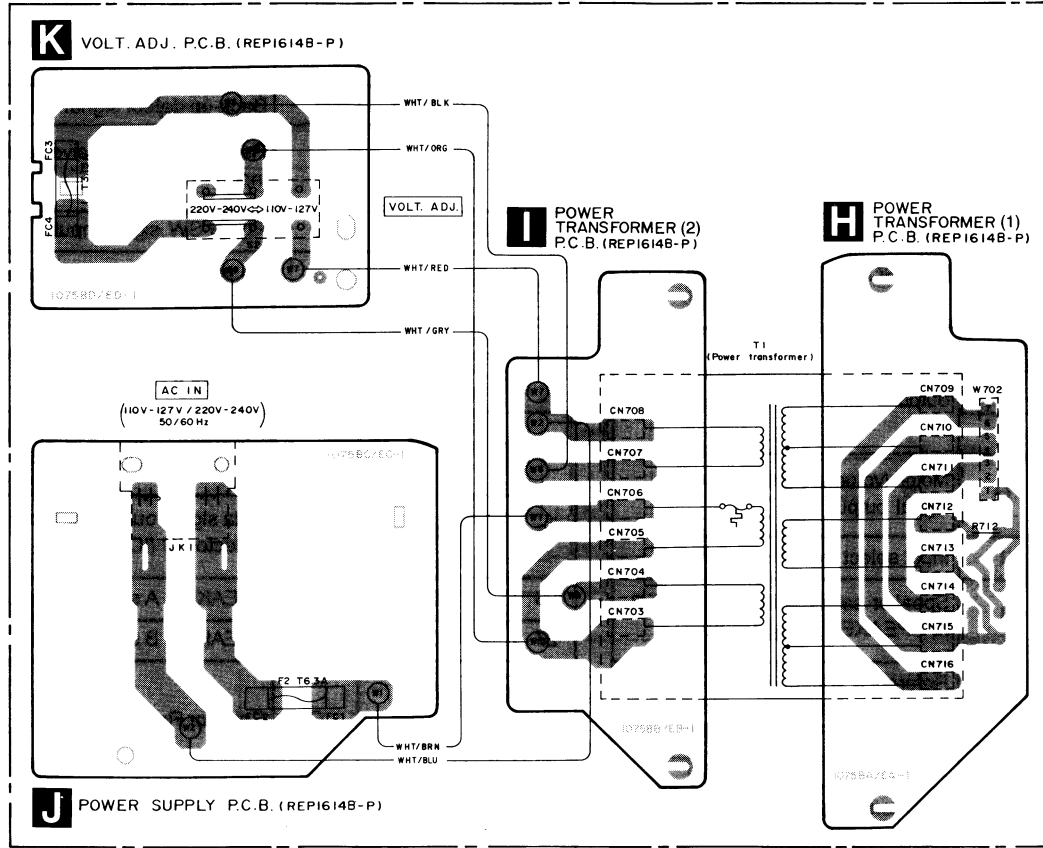

● Terminal guide of IC's, transistors and diodes

<p>M5218AP</p>	<p>UPC4570C 8 Pin</p> <p>NJU7312AL 28Pin</p>	<p>TC74HC42AP 16Pin</p> <p>M37470M2232S 32Pin</p>	<p>BA6218</p>
<p>RSN6000A</p> <p>SVI3205B</p>	<p>MN1381STA</p>	<p>2SA933QRSA</p> <p>2SA992EFPTA</p> <p>2SA1123RSTTA</p> <p>2SB621A-R</p> <p>2SC2631RSTTA</p> <p>2SD893RTA</p>	<p>2SK389BG</p>
	<p>2SA1309AIRTA</p> <p>2SC3311AIRTA</p> <p>UN421FTA</p> <p>UN4111</p> <p>UN4113TA</p> <p>UN4211</p> <p>UN4213</p>		<p>2SK170BLTPE2</p> <p>2SK301QRS</p>
	<p>MA165</p> <p>MA167</p> <p>MA29WA</p> <p>MA700</p> <p>1SS291TA</p> <p>1SR35200TB</p>		<p>MA4056MTA</p> <p>MA4068L</p>
	<p>MA4120</p> <p>MA4160M</p> <p>MA4360MTA</p>	<p>P300DLF</p>	<p>LN014305P</p> <p>LN018305P</p>

Wiring Connection Diagram

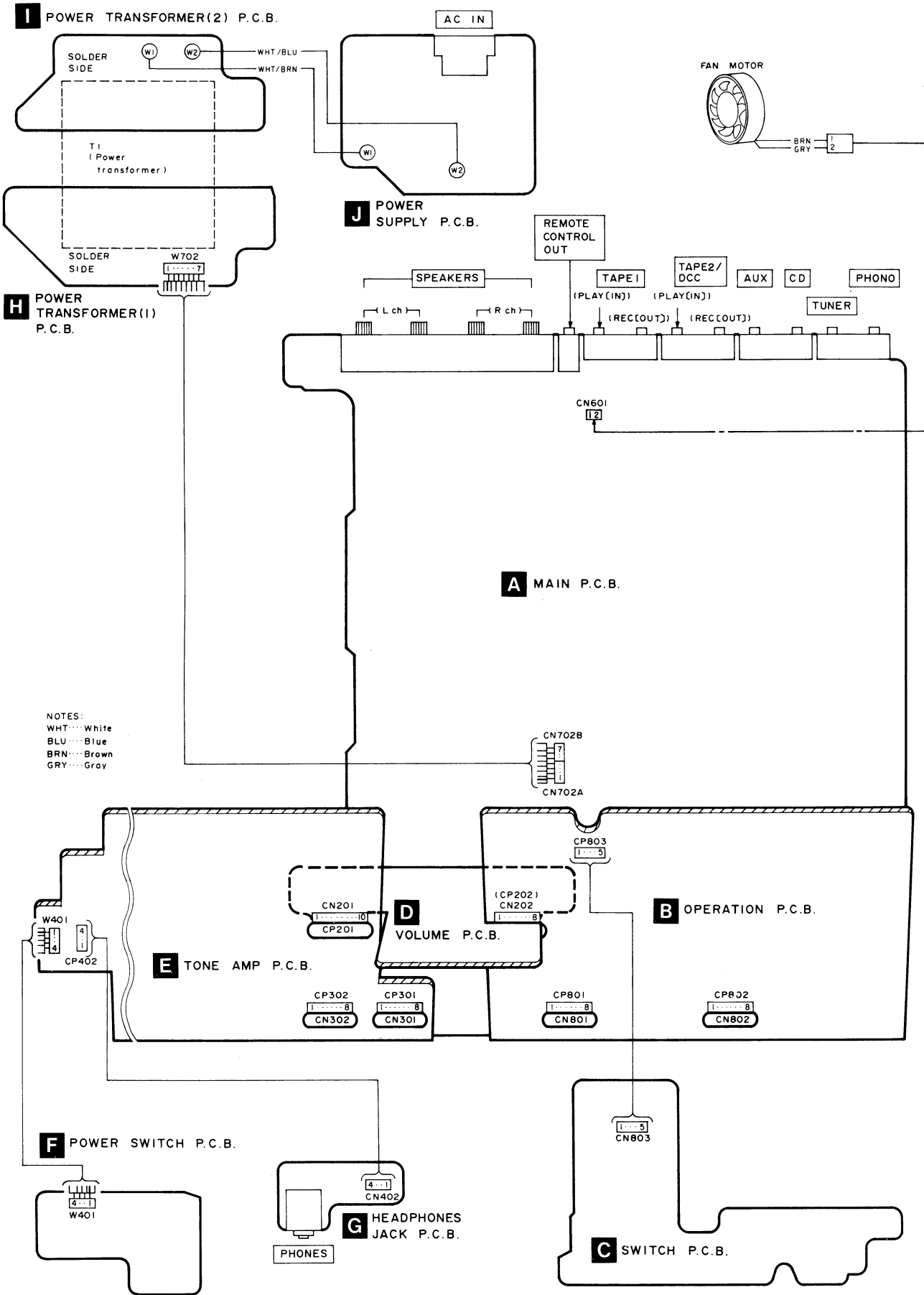

Block Diagram

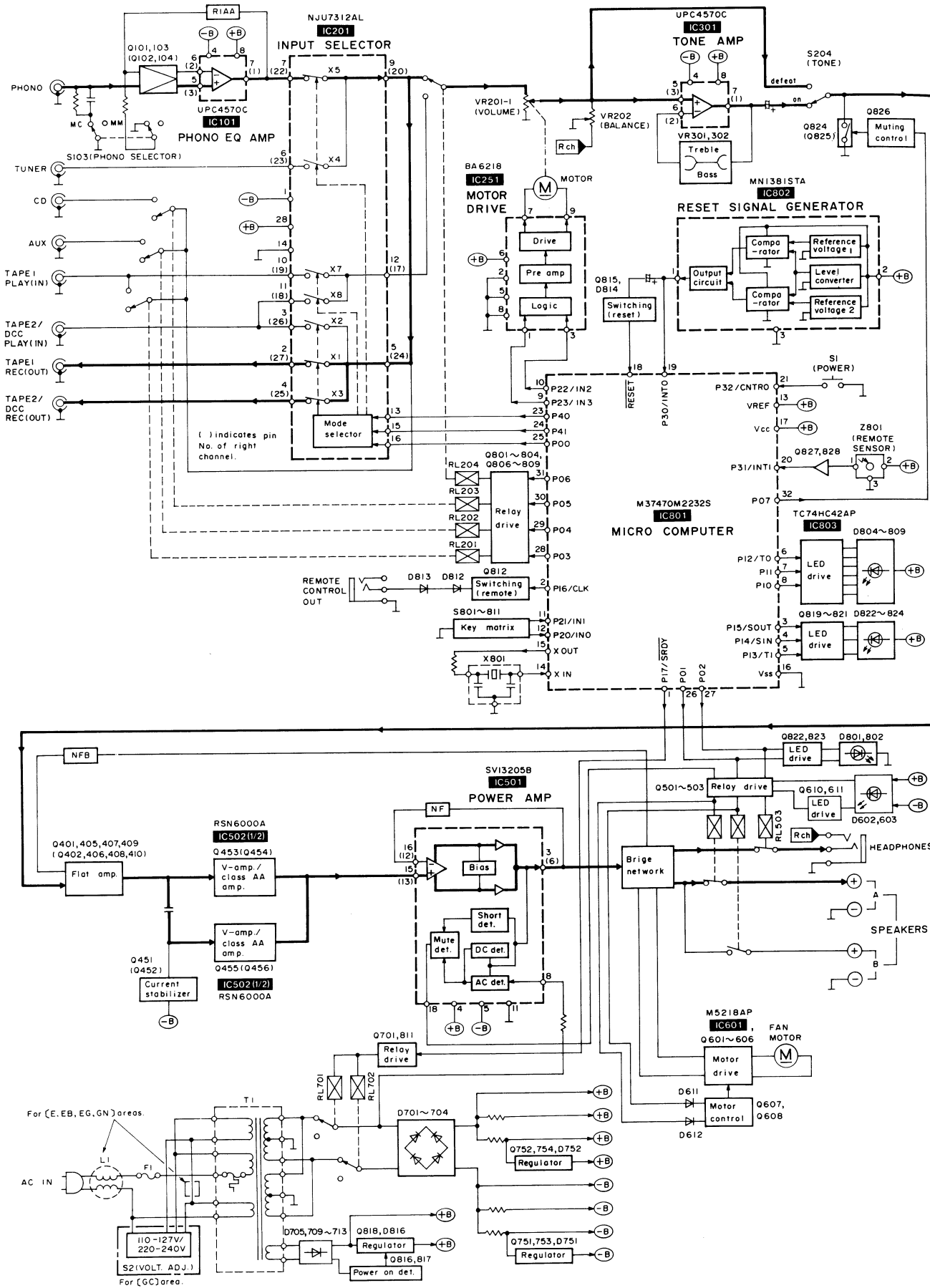

■ Function of IC Terminals

IC801 (M37470M2232S)

Pin No.	Terminal Name	I/O	Function
1	P17/SRDY	O	Relay (Power SW) drive signal output.
2	P16/CLK	O	Remote control signal output.
3	P15/SOUT	O	LED (TAPE 1) drive signal output.
4	P14/SIN	O	LED (TAPE 2) drive signal output.
5	P13/TI	O	LED (SOURCE) drive signal output.
6	P12/TO	O	Input select LED drive signal output.
7	P11	O	
8	P10	O	
9	P23/IN3	O	Motor (volume control) drive signal output.
10	P22/IN2		
11	P21/IN1	I	Input select switch signal input.
12	P20/IN0	I	Speaker select switch (SPEAKER A, SPEAKER B) signal input.
13	VREF	I	Reference voltage input.
14	XIN	I	Oscillator signal I/O terminal. (4 MHz)
15	XOUT	O	
16	VSS	—	GND terminal.
17	VCC	I	Power supply (+5V).

Pin No.	Terminal Name	I/O	Function
18	RESET	I	System reset signal input.
19	P30/INTO	I	Back-up detect signal input.
20	P31/INTI	I	Remote control receive signal input.
21	P32/CNRO	I	Power SW signal input.
22	P33/CNRI	—	No used. Connected to reference voltage line.
23	P40	O	Strobe signal output for Input Selector IC (IC201).
24	P41	O	Clock signal output for Input Selector IC (IC201).
25	P00	O	Data signal output for Input Selector IC (IC201).
26	P01	O	SPEAKER A select signal output.
27	P02		SPEAKER B select signal output.
28 } 31	P03 } P06	O	Selector Relay drive signal output.
32	P07	O	Audio muting control signal output.

■ Replacement Parts List

Notes: *Important safety notice:

 Components identified by Δ mark have special characteristics important for safety.

Furthermore, special parts which have purposes of fire-retardant (resistors), high-quality sound (capacitors), low-noise (resistors), etc. are used.

When replacing any of components, be sure to use only manufacturer's specified parts shown in the parts list.

*The parenthesized indications in the Remarks columns specify the areas. (Refer to the cover page for area.)

Parts without these indications can be used for all areas.

*Remote Control Ass'y: Supply period for three years from termination of production.

*The "(SF)" mark denotes the standard part.

Ref. No.	Part No.	Part Name & Description	Remarks	Ref. No.	Part No.	Part Name & Description	Remarks
				Q824, 825	2SK301QRS	TRANSISTOR	
		INTEGRATED CIRCUIT(S)		Q826	2SA933QRSTA	TRANSISTOR	
				Q827	2SC3311AIRTA	TRANSISTOR	
IC101	UPC4570C	I. C, PHONO EQ. AMP.		Q828	UN4111	TRANSISTOR	
IC201	NJU7312AL	I. C, INPUT SELECTOR				DIODE (S)	
IC251	BA6218	I. C, VOLUME MOTOR DRIVE					
IC301	UPC4570C	I. C, TONE AMP.		D101, 102	MA165	DIODE	
IC501	SV13205B	I. C, POWER AMP.	Δ	D401-404	MA165	DIODE	
IC502	RSN6000A	I. C, V-AMP.		D405, 406	MA167	DIODE	
IC601	M5218AP	I. C, FAN MOTOR DRIVE		D407, 408	MA165	DIODE	
IC801	M37470M232S	I. C, MICRO COMPUTER		D451	MA165	DIODE	
IC802	MN1381STA	I. C, RESET		D452	MA4056MTA	DIODE	Δ
IC803	TC74HC42AP	I. C, LED DRIVE		D453	MA29WA	DIODE	
		TRANSISTOR(S)		D501, 502	MA165	DIODE	
				D503, 504	MA4160M	DIODE	Δ
Q101-104	2SK170BLTPE2	TRANSISTOR		D505	MA165	DIODE	
Q401, 402	2SK389BG	TRANSISTOR		D506	1SS291TA	DIODE	
Q405-408	2SC2631RSTTA	TRANSISTOR		D602, 603	LN018305PH	L. E. D.	
Q409, 410	2SA1123RSTTA	TRANSISTOR		D605	MA4120	DIODE	
Q451, 452	2SC2631RSTTA	TRANSISTOR		D606-610	MA165	DIODE	
Q453, 454	2SC3311AIRTA	TRANSISTOR		D611, 612	MA167	DIODE	
Q455, 456	2SA1309AIRTA	TRANSISTOR		D613	MA165	DIODE	
Q501-503	2SA992EFPTA	TRANSISTOR		D615	MA4360MTA	DIODE	
Q601	2SD893R	TRANSISTOR		D616	MA165	DIODE	
Q602	2SA933QRSTA	TRANSISTOR		D701-704	P300DLF	DIODE	Δ
Q603, 604	2SA933QRSTA	TRANSISTOR		D705	1SR35200TB	DIODE	
Q605, 606	2SC3311AIRTA	TRANSISTOR		D706	MA165	DIODE	
Q607	UN4113TA	TRANSISTOR		D709	MA165	DIODE	
Q608	UN4213	TRANSISTOR		D710-713	1SR35200TB	DIODE	Δ (E, EB, EG, GN)
Q610	2SC3311AIRTA	TRANSISTOR		D751, 752	MA4160M	DIODE	Δ
Q611	UN421FTA	TRANSISTOR		D753, 754	MA165	DIODE	
Q701	2SB621A-R	TRANSISTOR		D801, 802	LN018305PH	L. E. D.	
Q751	2SD1265PQ	TRANSISTOR	Δ	D804-809	LN018305PH	L. E. D.	
Q752	2SB941-P	TRANSISTOR	Δ	D812-814	MA165	DIODE	
Q753	2SK330GRYTA	TRANSISTOR	Δ	D815	1SS291TA	DIODE	
Q754	2SJ105GRYTA	TRANSISTOR	Δ	D816	MA4068L	DIODE	Δ
Q801-804	UN4111	TRANSISTOR		D817	MA165	DIODE	
Q806-809	UN4211	TRANSISTOR		D822, 823	LN014305PH	L. E. D.	
Q811, 812	UN4211	TRANSISTOR		D824	LN018305PH	L. E. D.	
Q813, 814	UN4111	TRANSISTOR		D825-828	MA165	DIODE	
Q815, 816	UN4211	TRANSISTOR		D829	MA700	DIODE	
Q817	2SC3311AIRTA	TRANSISTOR		D830-832	MA165	DIODE	
Q818	2SD2037DEFTA	TRANSISTOR	Δ			VARIABLE RESISTOR (S)	
Q819-821	UN4211	TRANSISTOR					
Q822, 823	UN4111	TRANSISTOR					

Ref. No.	Part No.	Part Name & Description	Remarks	Ref. No.	Part No.	Part Name & Description	Remarks
VR201	EWCPG3020A15	V. R, MAIN VOLUME CONTROL					
VR202	EVJ02QF01G15	V. R, BALANCE				CONNECTOR(S)	
VR301, 302	EVJA1F01C15	V. R, BASS/TREBLE CONTROL					
		THERMISTOR(S)		CN201	RJU003K010M1	SOCKET (10P)	
				CN202	RJU003K008M1	SOCKET (8P)	
TH201, 202	ERTD2ZHL104T	THERMISTOR		CN301, 302	RJU003K008M1	SOCKET (8P)	
		COMPONENT COMBINATION (S)		CN402	RJU057W004	SOCKET (4P)	
				CN601	SJT3213	CONNECTOR (2P)	
Z801	RCDHC-278N	REMOTE SENSOR		CN703-716	RJS1A1101T1	SOCKET (1P)	
		COIL (S)		CN801, 802	RJU003K008M1	SOCKET (8P)	
				CN803	RJU066H05	SOCKET (5P)	
L1	RLQZ271M	COIL	△ (E, EB, EG, GN)	CN702A	RJS1A6604	CONNECTOR (4P)	
L101-104	ELEXT101KA9	COIL		CN702B	RJS1A6603	CONNECTOR (3P)	
L251, 252	ELEXT1R0KA9	COIL		CP201	RJT003K010-1	CONNECTOR (10P)	
L501-504	SLQY18G-10	COIL		CP202	RJT003K008-1	CONNECTOR (8P)	
L551	ELEPK2R2MA	COIL		CP301, 302	RJT003K008-1	CONNECTOR (8P)	
L801	ELEXT101KA9	COIL		CP402	RJT057W004-1	CONNECTOR (4P)	
		TRANSFORMER (S)		CP801, 802	RJT003K008-1	CONNECTOR (8P)	
				CP803	RJT066H05A	CONNECTOR (5P)	
T1	RTP7L5B001-W	POWER TRANSFORMER	△ (EB, GC, GN)			JACK(S)	
T1	RTP7L5E001-W	POWER TRANSFORMER	△ (E, EG)				
		OSCILLATOR(S)		JK1	SJS9236	AC INLET	△ (E, EB, EG, GC)
				JK1	SJSD16	AC INLET	△ (GN)
X801	EF0GC4004A4	OSCILLATOR (4MHz)		JK201	SJF3069N	INPUT TERMINAL (PHONO/TUNER)	
		FUSE (S)		JK202	SJF3069N	INPUT TERMINAL (CD/AUX)	
				JK203	SJF3069N	IN/OUTPUT (TAPE2/DCC)	
F1	XBA2C31TBO	FUSE, 250V, 3. 15A	△	JK204	SJF3069N	IN/OUTPUT (TAPE1)	
F2	XBA2C63TBO	FUSE, 250V T6. 3A	△ (GC)	JK501	RJH4801-2	SPEAKERS TERMINAL	(EB)
		SWITCH(ES)		JK501	RJH4801-1	SPEAKERS TERMINAL	(E, EG, GC, GN)
				JK502	QJA0455ZC-A	HEADPHONES JACK	
S1	EVQ21405R	SW, POWER		JK801	RJJ33TR01	REMOTE CONTROL OUT JACK	
S2	ESD26200A	SW, VOLTAGE SELECTOR	△ (GC)			EARTH TERMINAL (S)	
S103	RSP2D010-J	SW, PHONO SELECTOR		E101, 102	SNE1004-2	GND PLATE	
S204	ESB68113	SW, TONE ON/DEFEAT		E103	SMC949	SHIELD PLATE	
S801	EVQ21405R	SW, TAPE MONITOR		E201	RSC0340	SHIELD PLATE	
S802	EVQ21405R	SW, INPUT SELECTOR(TAPE1)				FUSE HOLDER(S)	
S803	EVQ21405R	SW, INPUT (TAPE2/DCC)		FC1, 2	EYF52BC	FUSE HOLDER	
S804	EVQ21405R	SW, INPUT SELECTOR(AUX)		FC3, 4	SJT388	FUSE HOLDER	(GC)
S805	EVQ21405R	SW, INPUT SELECTOR(CD)				RELAY (S)	
S806	EVQ21405R	SW, INPUT SELECTOR(TUNER)		RL201-204	RSY0020M-R	RELAY	
S807	EVQ21405R	SW, INPUT SELECTOR(PHONO)		RL501, 502	RSY0013-0	RELAY	△
S808	EVQ21405R	SW, INPUT SELECTOR(LEFT)		RL503	RSY0020M-R	RELAY	
S809	EVQ21405R	SW, INPUT SELECTOR(RIGHT)		RL701, 702	RSY0019M-0	RELAY	△
S810	EVQ21405R	SW, SPEAKER(A)					
S811	EVQ21405R	SW, SPEAKER(B)					

Notes : * Capacity values are in microfarads (μF) unless specified otherwise, P=Pico-farads (pF) F=Farads (F)
 * Resistance values are in ohms, unless specified otherwise, 1K=1,000(OHM) , 1M=1,000k(OHM)

Ref. No.	Part No.	Values & Remarks	Ref. No.	Part No.	Values & Remarks	Ref. No.	Part No.	Values & Remarks
		RESISTORS	R470	ERDS2TJ102	1/4W 1K	R715	ERDS1FVJ331T	1/2W 330 Δ
			R501, 502	ERDS2TJ392T	1/4W 3.9K	R751, 752	ERDS2TJ105T	1/4W 1M
			R503, 504	ERDAF2VJ121T	1/4W 120 Δ	R753, 754	ERDS2TJ333	1/4W 33K
R101-104	ERDS2TJ102	1/4W 1K	R505, 506	ERDS2TJ392T	1/4W 3.9K	R801, 802	ERDS2TJ391	1/4W 390
R105, 106	ERDS2TJ473	1/4W 47K	R507, 508	ERDAF2VJ121T	1/4W 120 Δ	R803	ERDS2TJ390	1/4W 39
R107, 108	ERDS2TJ221	1/4W 220	R513-516	ERDAF2VJ100T	1/4W 10 Δ	R804	ERDS2TJ331	1/4W 330
R109, 110	ERDS2TJ220T	1/4W 22	R519, 520	ERDS1FVJ6R8T	1/2W 6.8 Δ	R810	ERDS2TJ102	1/4W 1K
R111-114	ERDAS3G332T	1/4W 3.3K	R521, 522	ERDS1FVJ100T	1/2W 10 Δ	R811	ERDS2TJ103	1/4W 10K
R115, 116	ERDAS3G472T	1/4W 4.7K	R527	ERDS2TJ223	1/4W 22K	R812	ERDS2TJ102	1/4W 1K
R117, 118	ERDS2TJ151	1/4W 150	R528	ERDS2TJ824	1/4W 820K	R813-817	ERDS2TJ103	1/4W 10K
R119, 120	ERDS2TJ100	1/4W 10	R529	ERDS2TJ124T	1/4W 120K	R818	ERDS2TJ821	1/4W 820
R121, 122	ERDS2TJ101	1/4W 100	R530	ERDS1FVJ472T	1/2W 4.7K Δ	R819	ERDS2TJ102	1/4W 1K
R123, 124	ERDS2TJ151	1/4W 150	R531, 532	ERDS1FVJ100T	1/2W 10 Δ	R820	ERDS2TJ122	1/4W 1.2K
R125, 126	ERDS2TJ682T	1/4W 6.8K	R533, 534	ERDS2TJ182	1/4W 1.8K	R821	ERDS2TJ152	1/4W 1.5K
R127, 128	ERDS2TJ823T	1/4W 82K	R535	ERDS2TJ562	1/4W 5.6K	R822	ERDS2TJ182	1/4W 1.8K
R129, 130	ERDS2TJ334	1/4W 330K	R550, 551	ERDS2TJ222	1/4W 2.2K	R823	ERDS2TJ222	1/4W 2.2K
R131, 132	ERDS2TJ561	1/4W 560	R555-558	ERG1SJ681E	1W 680	R824	ERDS2TJ332	1/4W 3.3K
R201-214	ERDAS3J102T	1/4W 1K	R559	ERG1SJ152E	1W 1.5K	R825	ERDS2TJ472	1/4W 4.7K
R215, 216	ERDLS2VJ332T	1/4W 3.3K	R560	ERG1SJ182E	1W 1.8K	R826, 827	ERDS2TJ103	1/4W 10K
R217, 218	ERDS2TJ334	1/4W 330K	R561, 562	ERG1SJ151E	1W 150	R828, 829	ERDS2TJ102	1/4W 1K
R251	ERDS1FVJ100T	1/2W 10 Δ	R563, 564	ERG1SJ181E	1W 180	R830	ERDS2TJ223	1/4W 22K
R301, 302	ERDAS3G561	1/4W 560	R565-570	ERDS2TJ223	1/4W 22K	R831	ERDS2TJ104	1/4W 100K
R303, 304	ERDS2TJ104	1/4W 100K	R604	ERDS2TJ181T	1/4W 180	R832	ERDS2TJ102	1/4W 1K
R305, 306	ERDS2TJ224T	1/4W 220K	R611-614	ERDAS3G223T	1/4W 22K	R833	ERDS2TJ103	1/4W 10K
R307, 308	ERDS2TJ392T	1/4W 3.9K	R615-618	ERDAS3G103T	1/4W 10K	R834	ERDS2TJ221	1/4W 220
R309, 310	ERDS2TJ223	1/4W 22K	R619	ERDS2TJ151	1/4W 150	R835	ERDS2TJ181T	1/4W 180
R311, 312	ERDS2TJ102	1/4W 1K	R620	ERDS2TJ153	1/4W 15K	R837, 838	ERDS2TJ102	1/4W 1K
R313, 314	ERDS2TJ392T	1/4W 3.9K	R621, 622	ERDS2TJ223	1/4W 22K	R839, 840	ERDS2TJ682T	1/4W 6.8K
R315, 316	ERDS2TJ222	1/4W 2.2K	R624	ERDS2TJ333	1/4W 33K	R843	ERDS2TJ472	1/4W 4.7K
R317, 318	ERDS2TJ391	1/4W 390	R625	ERDS2TJ223	1/4W 22K	R845	ERDS2TJ334	1/4W 330K
R319, 320	ERDS2TJ183T	1/4W 18K	R626	ERDS2TJ103	1/4W 10K	R852, 853	ERDS2TJ103	1/4W 10K
R401, 402	ERDLS2VJ102T	1/4W 1K	R628	ERDS2TJ564	1/4W 560K	R854	ERDS2TJ471	1/4W 470
R403, 404	ERDAS3G823T	1/4W 82K	R629	ERDS2TJ473	1/4W 47K	R860-862	ERDS2TJ104	1/4W 100K
R405, 406	ERDLS2VJ102T	1/4W 1K	R630	ERDS2TJ120T	1/4W 12	R863	ERDS2TJ102	1/4W 1K
R407, 408	ERDAS3G184T	1/4W 180K	R632	ERDS2TJ102	1/4W 1K	R864	ERDS2TJ223	1/4W 22K
R409-412	ERDAS3G562T	1/4W 5.6K	R633	ERDS2TJ563	1/4W 56K			
R413, 414	ERDAS3G101T	1/4W 100	R634	ERDS2TJ223	1/4W 22K			CAPACITORS
R415, 416	ERDS2TJ183T	1/4W 18K	R635, 636	ERDS2TJ103	1/4W 10K	C101, 102	ECBT1H101KB5	50V 100 μ
R417, 418	ERDAS3J271T	1/4W 270	R637	ERDS2TJ222	1/4W 2.2K	C103, 104	ECBT1H102KB5	50V 1000 μ
R419, 420	ERDAS3G822T	1/4W 8.2K	R650	ERDS2TJ562	1/4W 5.6K	C105, 106	ECBT1H820KB5	50V 82 μ
R421, 422	ERDAS3G153T	1/4W 15K	R651	ERDS2TJ912T	1/4W 9.1K	C107, 108	ECA0JM222B	6.3V 2200 μ
R423-426	ERDAS3G101T	1/4W 100	R652	ERDS2TJ333	1/4W 33K	C109, 110	ECKW1H222KB5	50V 2200 μ
R427-430	ERDAF2VJ122T	1/4W 1.2K Δ	R707, 708	ERDAF2VJ6R8T	1/4W 6.8 Δ	C111, 112	ECQB1H122JF3	50V 1200 μ
R431, 432	ERDAF2VJ101T	1/4W 100 Δ	R709	ERDAF2VJ470T	1/4W 47 Δ	C113, 114	ECQB1H103JF3	50V 0.01 μ
R457	ERDS2TJ183T	1/4W 18K	R710	ERDS1FVJ331T	1/2W 330 Δ	C115, 116	ECQB1H393JF3	50V 0.039 μ
R459, 460	ERDAF2VJ101T	1/4W 100 Δ	R711	ERDS2TJ222	1/4W 2.2K	C117, 118	ECA1HPXS010B	50V 1 μ
R461-464	ERDS2TJ333	1/4W 33K	R712	ERDAF2VJ1ROT	1/4W 1.0 Δ	C119, 120	ECQB1H472JF3	50V 4700 μ
R465-468	ERDAF2VJ101T	1/4W 100 Δ	R713	ERDS2TJ223	1/4W 22K	C121, 122	ECQB1H103JF3	50V 0.01 μ
R469	ERDS2TJ103	1/4W 10K	R714	ERDS2TJ222	1/4W 2.2K			

Ref. No.	Part No.	Values & Remarks	Ref. No.	Part No.	Values & Remarks
C123-126	ECBT1H270J5	50V 27P	C755, 756	ECEA1HBZ4R7B	50V 4. 7U
C127, 128	ECBT1H101KB5	50V 100P	C757, 758	ECA2APXS100B	100V 10U
C129, 130	ECBT1E103ZF	25V 0. 01U	C801-803	ECBT1C103NS5	16V 0. 01U
C201-214	ECKT1H101KB	50V 100P	C804	ECA1AM102B	10V 1000U
C251, 252	ECEAOJKA101B	6. 3V 100U	C805	ECEA1HKAR47B	50V 0. 47U
C253, 254	ECBT1H104ZF5	50V 0. 1U	C806	ECEA1HKA2R2B	50V 2. 2U
C301, 302	ECA1HPXS3R3B	50V 3. 3U	C807	ECBT1H102KB5	50V 1000P
C303, 304	ECCR1H101K5	50V 100P	C808	ECEAOJKA101B	6. 3V 100U
C305, 306	ECBT1H820KB5	50V 82P	C809	ECBT1C103NS5	16V 0. 01U
C307, 308	ECA1HPXS4R7B	50V 4. 7U	C810	ECEA1AKA470B	10V 47U
C309, 310	ECBT1H390J5	50V 39P	C811	ECBT1H101KB5	50V 100P
C311, 312	ECA1CPXS100B	16V 10U	C812, 813	ECKR1H103ZF5	50V 0. 01U
C313, 314	ECQV1H823JM3	50V 0. 082U	C814, 815	ECA1HPXS4R7B	50V 4. 7U
C315, 316	ECQB1H153JF3	50V 0. 015U	C820	ECQV1H224JM3	50V 0. 22U
C317, 318	ECQB1H183JF3	50V 0. 018U	C821	ECBT1H473ZF5	50V 0. 047U
C319, 320	ECQB1H222JF3	50V 2200P			
C321, 322	ECBT1E223ZF	25V 0. 022U			
C323, 324	ECBT1H121KB5	50V 120P			
C403, 404	ECKR1H271KB5	50V 270P			
C405, 406	RCE1EAS470B	25V 47U			
C407, 408	ECCR1H070D5	50V 7P			
C409, 410	ECKR1H391KB5	50V 390P			
C411, 412	ECCR1H030C5	50V 3P			
C413, 414	ECQB1H222JF3	50V 2200P			
C451, 452	ECKR1H333ZF5	50V 0. 033U			
C453-456	ECCV2H680K	500V 68P			
C457-460	ECEA1HKA3R3B	50V 3. 3U			
C501-504	ECA0JPXS101B	6. 3V 100U			
C505, 506	ECQV1H473JM3	50V 0. 047U			
C507	ECEA1CKA101B	16V 100U			
C508	ECA1HM470B	50V 47U			
C509	ECEA1HN100SB	50V 10U			
C511, 512	ECBT1H270J5	50V 27P			
C513-518	ECQV1H473JM3	50V 0. 047U			
C519-522	ECQB1H393JF3	50V 0. 039U			
C523, 524	ECBT1H102KB5	50V 1000P			
C525, 526	ECKD1H821KB	50V 820P			
C531, 532	ECBT1C332KR5	16V 3300P			
C601	ECEA1HKAR47B	50V 0. 47U			
C602	ECEA1CKA100B	16V 10U			
C603	ECEA1HKA3R3B	50V 3. 3U			
C604	ECEA1HKAD10B	50V 1U			
C605	ECEAOJKA331B	6. 3V 330U			
C701, 702	ECETX1J123WX	63V 12000U Δ			
C707, 708	ECA1JPXH560E	63V 56U			
C709, 710	ECQE2334KFW	250V 0. 33U			
C711	ECQE2104KF3	250V 0. 1U			
C712	ECBT1C103NS5	16V 0. 01U			
C714	ECA1CM471B	16V 470U			
C715	ECEA1HKA2R2B	50V 2. 2U			
C716	ECA1CM102B	16V 1000U Δ			
C751-754	ECA1EPXS470B	25V 47U			

■ Cabinet Parts Location

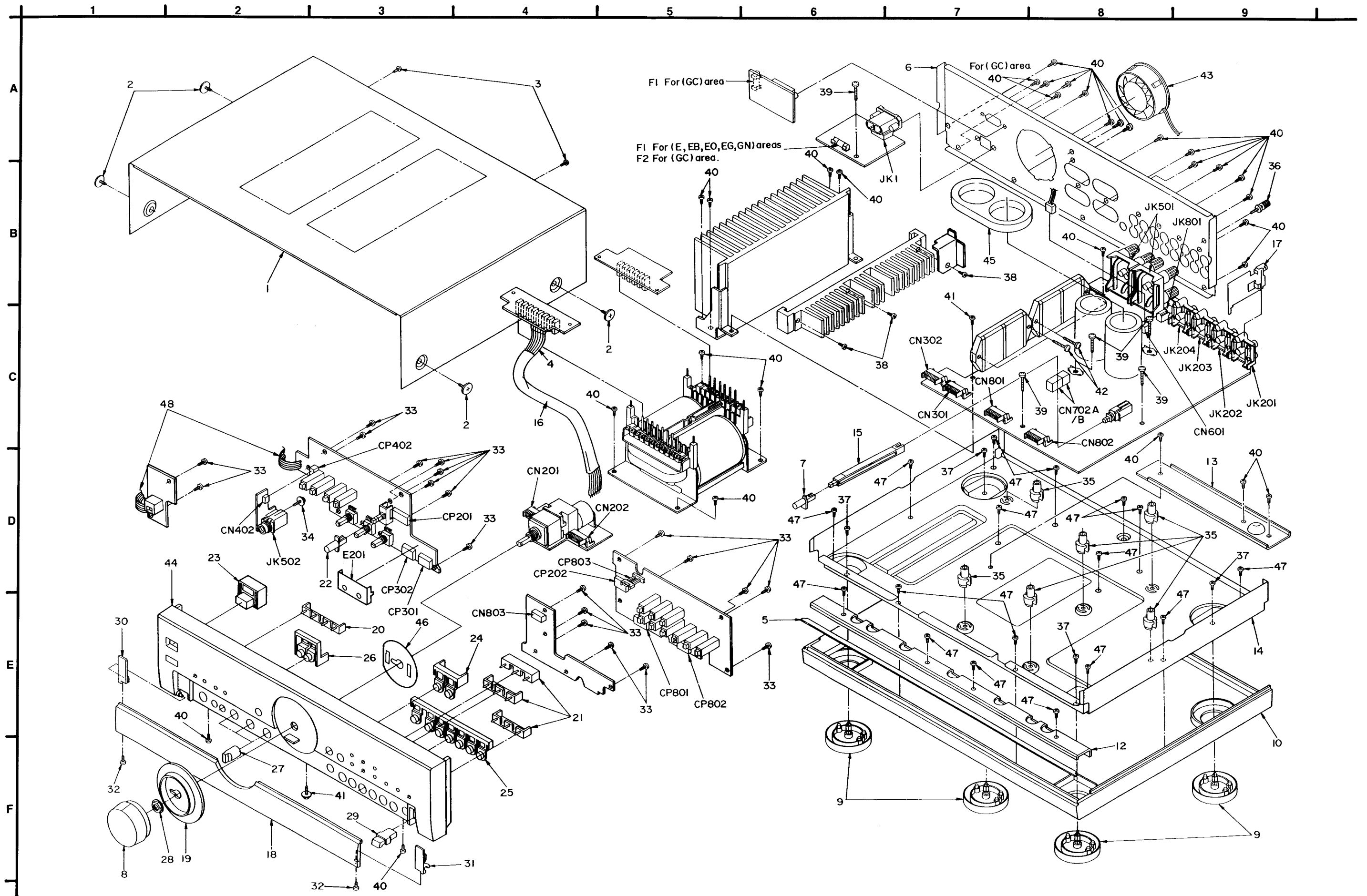

Ref. No.	Part No.	Part Name & Description	Remarks
		CABINET PARTS LIST	
1	RKM0089C-1K	CABINET	
2	RHD30035-K1	SCREW	
3	XTBS3+8JFZ1	SCREW	
4	RWJ3907330QQ	FLAT CABLE (7P) (W702)	
5	RGK0588-T	ORNAMENT RUBBER	
6	RGR0171E-C1C	REAR PANEL	(EB)
6	RGR0171A-EB	REAR PANEL	(E, EG)
6	RGR0171A-F1C	REAR PANEL	(GN)
6	RGR0171B-CC	REAR PANEL	(GC)
7	RGU0609-K	BUTTON, PHONO SELECTOR	
8	RGW0203-K	KNOB, VOLUME	
9	RKA0053-A	FOOT	
10	RKU0051-K	RUBBER BASE	
12	RMA0818	ANGLE	
13	RMA0744-1	ANGLE	
14	RMK0190B-2	BOTTOM CHASSIS	
15	RMMD104	SWITCH SHAFT	
16	RWZ120UNW240	TUBE	
17	RSCO322	SHIELD PLATE (PHONO)	
18	RKFO314-K	OPERATION DOOR	
19	RGK0630-S	ORNAMENT	
20	RGLO189-Q	PANEL LIGHT (A)	
21	RGLO190-Q	PANEL LIGHT (B)	
22	RGU0282	BUTTON, TONE	
23	RGU0882-K	BUTTON, POWER	
24	RGU0891-K	BUTTON, INPUT SELECTOR	
25	RGU0892-K	BUTTON, TAPE MONITOR etc.	
26	RGU0893-K	BUTTON, SPEAKERS	
27	RGW0178-K	KNOB, BASS/TREBLE etc.	
28	RHIN90001	NUT	
29	RMQ0215A	DOOR STOPPER	
30	RMQ0378	DOOR HOLDER (R)	
31	RMQ0379	DOOR HOLDER (L)	
32	XQN26+AJ6FZ	SCREW	
33	XTBS26+8J	SCREW	
34	XTWS3+8T	SCREW	
35	SHE187-2	P. C. B. SUPPORT	
36	SNE2123	GND SCREW	
37	XTB3+14G	SCREW	
38	XTB3+16JFZ	SCREW	
39	XTB3+20JFZ	SCREW	
40	XTBS3+8JFZ1	SCREW	
41	XTWS3+8T	SCREW	
42	XTW3+15T	SCREW	
43	REMO040	FAN MOTOR	
44	RFKGA900MKEB	FRONT PANEL ASS'Y	
45	RFMD174	CUSHION	
46	RSCO323	SHIELD PLATE (VOLUME)	
47	XTB3+8GFZ	SCREW	
48	REZ0663	FLAT CABLE (4P) (W401)	

Ref. No.	Part No.	Part Name & Description	Remarks
		PACKING MATERIALS	
P1	RPG2035	PACKING CASE	(EB)
P1	RPG2034	PACKING CASE	(E, EG, GC, GN)
P2	RPN0685	PAD	
P3	RPQ0164	ACCESSORY PAD	
P4	XZB50X65A02Z	PROTECTION COVER	
P5	XZB24X34C04	PROTECTION COVER	
P6	RP10032	PROTECTION SHEET	(EB, GN)
		ACCESSORIES	
A1	RAK-SU129WH	REMOTE CONTROL TRANSMITTER	
A1-1	RKK0057-K	BATTERY COVER	
A2	VJA0733	AC POWER SUPPLY CORD	△ (EB) (SF)
A2	RJA0019-2K	AC POWER SUPPLY CORD	△ (E, EG, GC) (SF)
A2	RJA0036-K	AC POWER SUPPLY CORD	△ (GN)
A3	RQA0013	WARRANTY CARD	(E, EB, EG)
A3	RQX7433ZA	WARRANTY CARD	(GN)
A4	RQCB0169	SERVICE CENTER LIST	
A5	RFKSA800MK2E	INSTRUCTIONS MANUAL	(E)
A5	RFKSA800MKEB	INSTRUCTIONS MANUAL	(EB, GN)
A5	RFKSA800MKEG	INSTRUCTIONS MANUAL	(EG)
A5	RFKSA900MKGC	INSTRUCTIONS MANUAL	(GC)
A7	SJP5213-2	POWER PLUG ADAPTOR	△ (GC)

■ Packaging

