

[Table Of Contents](#)
[COVER](#)
[1 Note](#)
[2 Location of Controls](#)
[3 To Supply Power Source](#)
[3.1 Power Supply to Main](#)
[Circuit](#)
[3.2 Operation Check](#)
[4 Operation Checks and Component](#)
[Replacement Procedures](#)
[5 Type Illustration of ICs](#)
[Transistors and Diodes](#)
[6 Schematic Diagram](#)
[6.1 Schematic Diagram](#)
[Notes](#)
[6.2 Schematic Diagram](#)
[7 Printed Circuit Board](#)
[Diagram](#)
[8 Block Diagram](#)
[9 Wiring Connection](#)
[Diagram](#)
[10 Measurements and Adjustments](#)
[10.1 Measurement](#)
[instruments and Special tools](#)
[10.2 Output Voltage](#)
[Adjustment](#)
[11 Terminal Function of ICs](#)
[11.1 IC701](#)
[\(M38503M2404F\) : Micro Computer](#)
[12 Replacement Parts List](#)
[13 Cabinet Parts Location](#)
[14 Packaging](#)

Service Manual

[TOP NEXT](#)

AD9907176C2

Control Amplifier

- SU-C909U

Colour

(K).....Black Type

Area

(E).....Europe and Russia.

Service Manual



Because of unique interconnecting cables, when a component requires service, send or bring in the entire system.

System: SU-A909

Control Amplifier	SU-C909U
Power Amplifier	SE-A909S

Specifications (DIN 45 500)

Input sensitivity/impedance:

PHONO MM;	2.5 mV/47 kΩ
TUNER, CD, DVD, AUX, TAPE 1, TAPE 2/MD;	200 mV/22 kΩ

Total harmonic distortion (VGCA ON)

(Vol. MAX, 20 Hz – 20 kHz):

PHONO MM;	0.01 %
TUNER, CD, DVD, AUX, TAPE 1, TAPE 2/MD;	0.01 %

S/N (VGCA ON):

PHONO MM;	75 dB (77 dB, IHF '66)
TUNER, CD, DVD, AUX, TAPE 1, TAPE 2/MD;	103 dB (100 dB, IHF '66)
	114 dB (IHF A S=2 V rated output)

Frequency response (VGCA ON):

PHONO MM;	RIAA standard curve ± 1 dB (20 Hz – 15 kHz)
-----------	--

Phono maximum input voltage (1 kHz, RMS):

MM;	90 mV (IHF '66)
-----	-----------------

Tone controls:

BASS;	+ 10 dB, –10 dB (50 Hz)
TREBLE;	+ 10 dB, –10 dB (20 kHz)

Muting:

–∞ dB

Output voltage:

TAPE 1, TAPE 2 REC OUT;	200 mV
PRE OUT;	1 V

■ GENERAL

Dimensions (W × H × D): 430 × 91.5 × 300 mm

Weight: 2.85 kg

Note:

**TUNER, CD, DVD-6CH, AUX,
TAPE 1, TAPE 2/MD;**

(30 Hz – 15 kHz)
3 Hz – 100 kHz (+0 dB, –3 dB)
+0 dB, –0.3 dB (20 Hz – 20 kHz)

Note:

- Specifications are subject to change without notice.
Weight and dimensions are approximate.

© 1999 Matsushita Electric Industrial Co., Ltd. All rights reserved. Unauthorized copying and distribution is a violation of law.

 **WARNING**

This service information is designed for experienced repair technicians only and is not designed for use by the general public. It does not contain warnings or cautions to advise non-technical individuals of potential dangers in attempting to service a product. Products powered by electricity should be serviced or repaired only by experienced professional technicians. Any attempt to service or repair the product or products dealt with in this service information by anyone else could result in serious injury or death.

Technics

•@

[TOP NEXT](#)

Table Of Contents

COVER

1 Note

2 Location of Controls

3 To Supply Power Source

3.1 Power Supply to Main Circuit

3.2 Operation Check

4 Operation Checks and Component Replacement Procedures

5 Type Illustration of ICs, Transistors and Diodes

6 Schematic Diagram

6.1 Schematic Diagram Notes

6.2 Schematic Diagram

7 Printed Circuit Board Diagram

8 Block Diagram

9 Wiring Connection Diagram

10 Measurements and Adjustments

10.1 Measurement instruments and Special tools

10.2 Output Voltage Adjustment

11 Terminal Function of ICs

11.1 IC701 (M38503M2404F) : Micro Computer

[12 Replacement Parts List](#)

[13 Cabinet Parts Location](#)

[14 Packaging](#)

Service Manual

Control Amplifier

- SU-C909U

Colour

(K).....Black Type

Area

(E).....Europe and Russia.

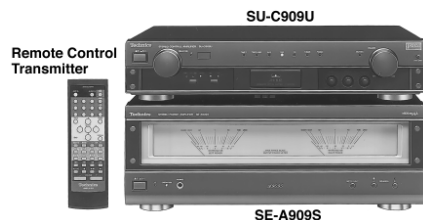

Because of unique interconnecting cables, when a component requires service, send or bring in the entire system.

System: SU-A909

Control Amplifier	SU-C909U
Power Amplifier	SE-A909S

Specifications (DIN 45 500)

Input sensitivity/impedance:

PHONO MM; 2.5 mV/47 kΩ

TUNER, CD, DVD, AUX,
TAPE 1, TAPE 2/MD; 200 mV/22 kΩ

Total harmonic distortion (VGCA ON)

(Vol. MAX, 20 Hz – 20 kHz):

PHONO MM; 0.01 %

TUNER, CD, DVD, AUX, TAPE 1, TAPE 2/MD; 0.01 %

S/N (VGCA ON):

PHONO MM; 75 dB (77 dB, IHF '66)

TUNER, CD, DVD, AUX,
TAPE 1, TAPE 2/MD; 103 dB (100 dB, IHF '66)

114 dB (IHF A S=2 V rated output)

Phono maximum input voltage (1 kHz, RMS):

MM; 90 mV (IHF '66)

Tone controls:

BASS; + 10 dB, -10 dB (50 Hz)

TREBLE; + 10 dB, -10 dB (20 kHz)

Muting: -∞ dB

Output voltage:

TAPE 1, TAPE 2 REC OUT; 200 mV

PRE OUT; 1 V

■ GENERAL

Dimensions (W × H × D): 430 × 91.5 × 300 mm

Weight: 2.85 kg

114 dB (IHF A S=2 V rated output)

Weight:

2.85 kg

Frequency response (VGCA ON):

PHONO MM;

RIAA standard curve ± 1 dB
(30 Hz – 15 kHz)

TUNER, CD, DVD-6CH, AUX,

TAPE 1, TAPE 2/MD;

3 Hz – 100 kHz (+0 dB, –3 dB)
+0 dB, –0.3 dB (20 Hz – 20 kHz)

Note:

- Specifications are subject to change without notice.
Weight and dimensions are approximate.

© 1999 Matsushita Electric Industrial Co., Ltd. All rights reserved. Unauthorized copying and distribution is a violation of law.

 **WARNING**

This service information is designed for experienced repair technicians only and is not designed for use by the general public. It does not contain warnings or cautions to advise non-technical individuals of potential dangers in attempting to service a product. Products powered by electricity should be serviced or repaired only by experienced professional technicians. Any attempt to service or repair the product or products dealt with in this service information by anyone else could result in serious injury or death.

Technics

•@

[TOP NEXT](#)

1 Note

[TOP](#) [PREVIOUS](#) [NEXT](#)

Refer to the service manual for Model No. SE-A909S (ORDER No. AD9907177C2) for information on Accessories, Connections, Operations and Packaging.

- @

[TOP](#) [PREVIOUS](#) [NEXT](#)

2 Location of Controls

[TOP](#) [PREVIOUS](#) [NEXT](#)

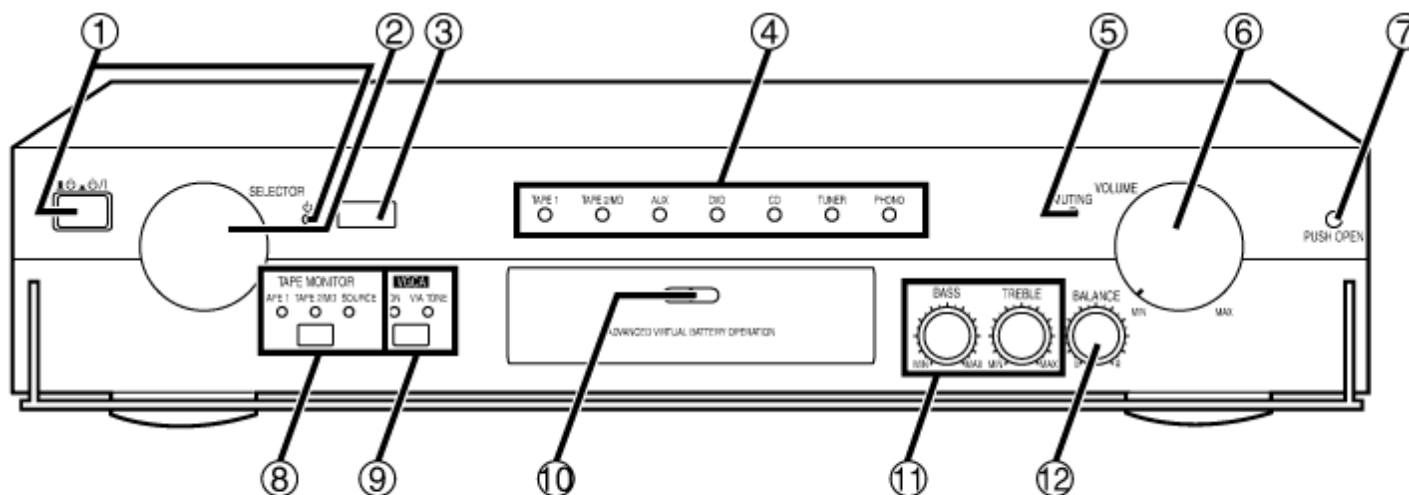

Main units

No.	Name
-----	------

- ① **Unit on/off button** ()
and remote standby indicator ()

Use this button to turn the unit on and off.

- (off): The unit is in standby mode.
- (on): The unit is on. The unit can be turned on and off with the remote control. When the unit is turned off with the remote control it is in remote standby and the indicator lights.





The unit is still using a small amount of power in the standby and remote standby conditions. Standby uses less power.

Note

The control amplifier switches between ON and the standby mode only if the power amplifier switch is in

No.	Name
-----	------

- ⑦ **Panel button (PUSH OPEN)**
 Press to open the clear panel. Close by hand.
- ⑧ **Tape monitor button/indicators (TAPE MONITOR)**
- ⑨ **VGCA button/indicators (**VGCA**)**
- ⑩ **“ADVANCED VIRTUAL BATTERY OPERATION” indicator**
 This will illuminate to indicate that the advanced virtual battery (a circuit which removes the noise contained in the power supply while playing a sound input source) is functioning.
- ⑪ **Tone controls (BASS, TREBLE)**
- ⑫ **Balance control (BALANCE)**

The control amplifier switches between ON and the standby mode only if the power amplifier [   ] switch is in the “  /I ” position.

- ② **Input selector (SELECTOR)**
- ③ **Remote control signal sensor**
- ④ **Input indicator**
- ⑤ **Muting indicator (MUTING)**
- ⑥ **Volume control (VOLUME)**

•@

[TOP](#) [PREVIOUS](#) [NEXT](#)

⑫ **Balance control (BALANCE)**

3 To Supply Power Source

[TOP](#) [PREVIOUS](#) [NEXT](#)

This unit SU-C909U is designed to operate on power supplied from the Power Amplifier SE-A909S.

When operating the unit SU-C909U alone for testing and servicing, without having power supplied from the Power Amplifier SE-A909S, use the following method.

[3.1 Power Supply to Main Circuit](#)

[3.2 Operation Check](#)

- @

[TOP](#) [PREVIOUS](#) [NEXT](#)

3.1 Power Supply to Main Circuit

[TOP](#) [PREVIOUS](#) [NEXT](#)

1. Apply 10 V AC power to the section between the point [TP1](#) and the point [TP2](#) . Shown in [Fig.1](#)
2. Connect the DC+12 V to+15 V (more than 0.1 A) to the point [TP5](#) , and the GND terminal to the point [TP4](#) using the DC power supply. Shown in [Fig.1](#)
3. Connect the DC -12 V to -15 V (more than 0.1 A) to the point [TP3](#) , and the GND terminal to the point [TP4](#) using the DC power supply. Shown in [Fig.1](#)

•@

[TOP](#) [PREVIOUS](#) [NEXT](#)

3.2 Operation Check

[TOP](#) [PREVIOUS](#) [NEXT](#)

1. Input a signal (1 kHz, 100 mV) to the each line-in terminal.
2. Connect the oscilloscope or the speaker with the built-in amplifier to the PRE OUT terminals and check if the signals are outputting from this unit.

Fig.1

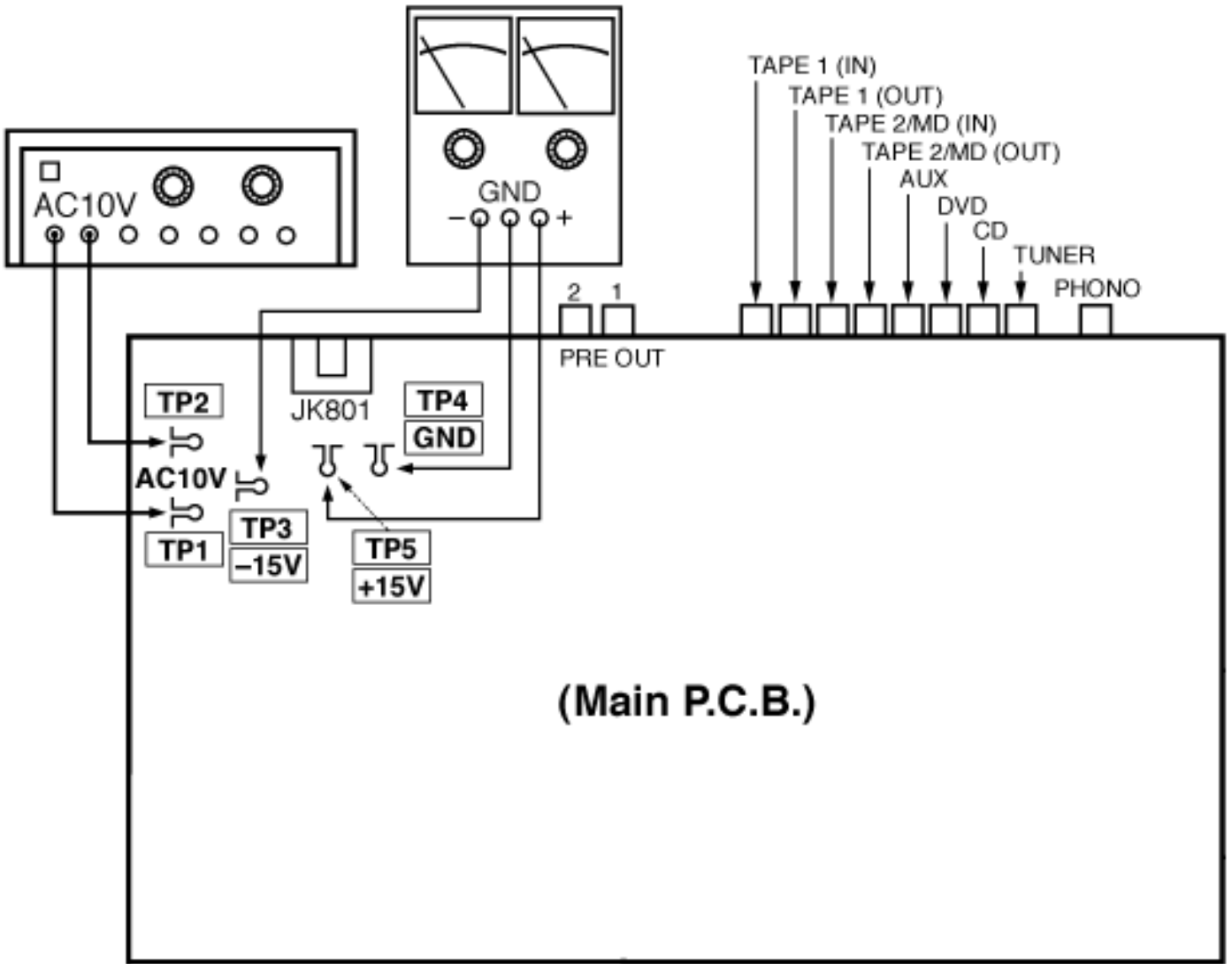

•@

[TOP](#) [PREVIOUS](#) [NEXT](#)

4 Operation Checks and Component Replacement/Procedures

[TOP](#) [PREVIOUS](#) [NEXT](#)

- NOTE**
1. This section describes procedures for checking the operation of the major printed circuit boards and replacing the main components.
 2. For reassembly after operation checks or replacement, reverse the respective procedures. Special reassembly procedures are described only when required.

1. Checking for the operation (1) P.C.B., operation (2) P.C.B. and main P.C.B.

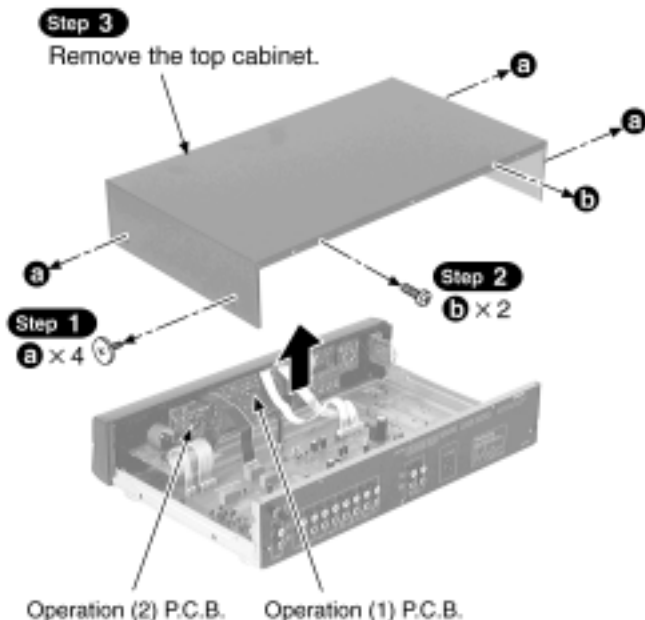

- Check the operation (1) P.C.B. and operation (2) P.C.B. as shown above

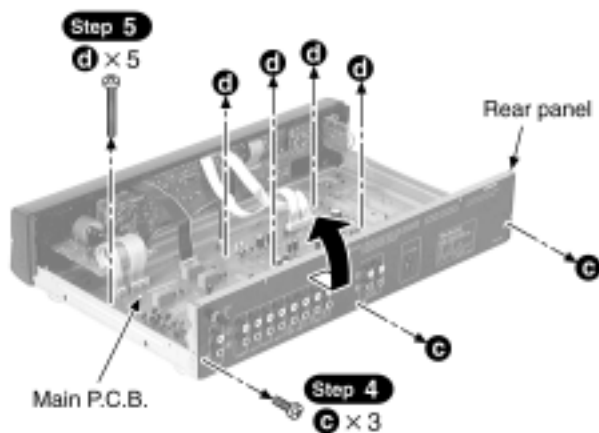

- Step 6**
Remove the main P.C.B. and rear panel in the direction of arrow.

- Check the main P.C.B. as shown below.

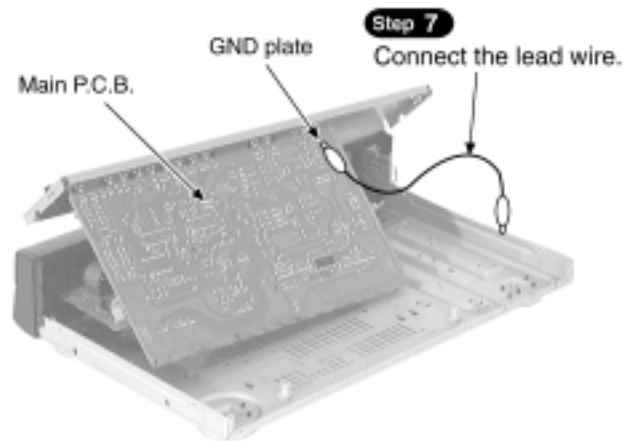

To remove each P.C.B.

- Follow the **Step 1** ~ **Step 3** of the item 1.

- Step 1**
Remove the 6 connectors.

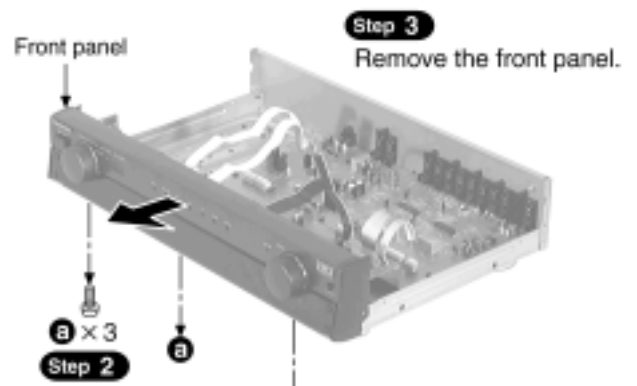
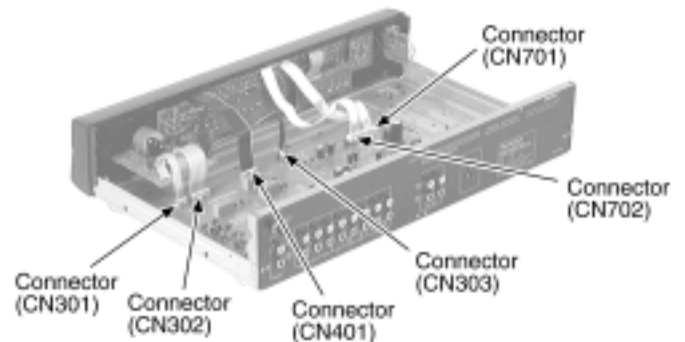

Main P.C.B.

Step 4
C × 3

Step 6

Remove the main P.C.B. and rear panel in the direction of arrow.

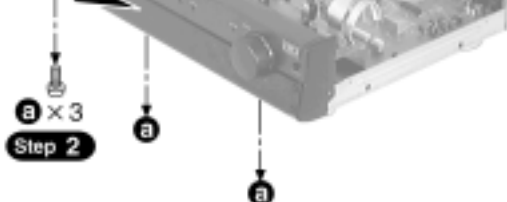

Step 4

Remove the volume knob and nut.

Step 6

Remove the selector knob and nut.

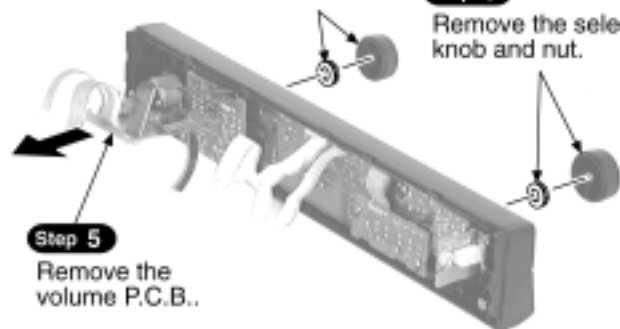

Step 5

Remove the volume P.C.B..

Step 15

Remove the operation (1) P.C.B..

Step 14

C × 6

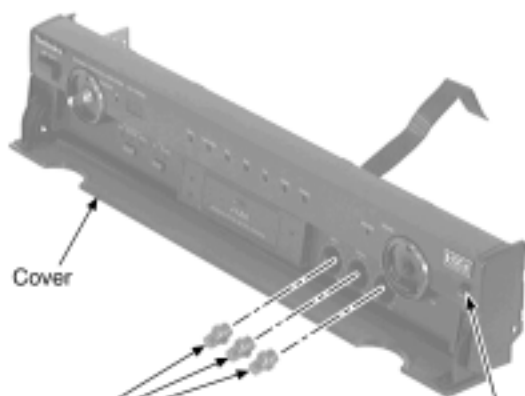
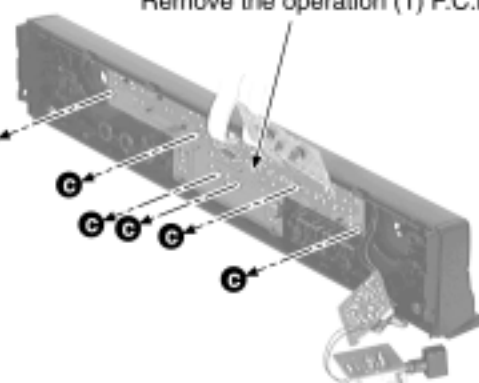

Step 8

Pull out the balance knob, treble knob and bass knob.

Open button

Step 7

Push the open button, and then open the cover.

Step 10

Remove the operation (2) P.C.B..

Step 11

Remove the operation (3) P.C.B..

Step 12

Remove the selector P.C.B..

Step 9

b × 8

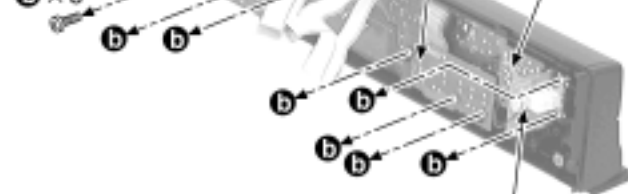

Step 13

Remove the power switch P.C.B..

Step 13

Remove the power
switch P.C.B..

•@

[TOP](#) [PREVIOUS](#) [NEXT](#)

5 Type Illustration of ICs, Transistors and Diodes

[TOP](#) [PREVIOUS](#) [NEXT](#)



•@

[TOP](#) [PREVIOUS](#) [NEXT](#)

6 Schematic Diagram

[TOP](#) [PREVIOUS](#) [NEXT](#)

[6.1 Schematic Diagram Notes](#)

[6.2 Schematic Diagram](#)

•@

[TOP](#) [PREVIOUS](#) [NEXT](#)

6.1 Schematic Diagram Notes

[TOP](#) [PREVIOUS](#) [NEXT](#)

- This schematic diagram may be modified at any time with the development of new technology.

Notes:

- S801:

VGCA switch (



- S802:

Tape monitor switch (TAPE MONITOR)

- S804:

Input select switch (SELECTOR)

- S805:

Unit on/off switch (



- VR301:

Volume control VR (VOLUME)

- VR311:

Output voltage adjustment VR (L ch)

- VR312:

Output voltage adjustment VR (R ch)

- VR401:

Balance control VR (BALANCE)

- VR402:

Tone control VR (BASS)

- VR403:

Tone control VR (TREBLE)

- Indicated voltage values are the standard values for the unit measured by the DC electronic circuit tester (high-impedance) with the chassis taken as standard. Therefore, there may exist some errors in the voltage values, depending on the internal impedance of the DC circuit tester.

No mark : Power ON

- Important safety notice:

Components identified by  mark have special characteristics important for safety.

Furthermore, special parts which have purposes of fire-retardant (resistors), high-quality sound (capacitors), low-noise (resistors), etc. are used.

When replacing any of components, be sure to use only manufacturers specified parts shown in the parts list.

- **Caution!**

IC and LSI are sensitive to static electricity.

Secondary trouble can be prevented by taking care during repair.

Cover the parts boxes made of plastics with aluminum foil.

Ground the soldering iron.

Put a conductive mat on the work table.

Do not touch the legs of IC or LSI with the fingers directly.

- Voltage and signal line

-



: Positive voltage line

-



: Negative voltage line

-

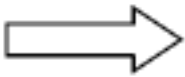

: Phono signal line

-



: Tape rec signal line

•@

[TOP](#) [PREVIOUS](#) [NEXT](#)

6.2 Schematic Diagram

[TOP](#) [PREVIOUS](#) [NEXT](#)



•@

[TOP](#) [PREVIOUS](#) [NEXT](#)

7 Printed Circuit Board Diagram

[TOP](#) [PREVIOUS](#) [NEXT](#)



•@

[TOP](#) [PREVIOUS](#) [NEXT](#)

8 Block Diagram

[TOP](#) [PREVIOUS](#) [NEXT](#)



•@

[TOP](#) [PREVIOUS](#) [NEXT](#)

9 Wiring Connection Diagram

[TOP](#) [PREVIOUS](#) [NEXT](#)



•@

[TOP](#) [PREVIOUS](#) [NEXT](#)

10 Measurements and Adjustments

[TOP](#) [PREVIOUS](#) [NEXT](#)

[10.1 Measurement instruments and Special tools](#)

[10.2 Output Voltage Adjustment](#)

•@

[TOP](#) [PREVIOUS](#) [NEXT](#)

10.1 Measurement instruments and Special tools

[TOP](#) [PREVIOUS](#) [NEXT](#)

- AC electric voltmeter (AC EVM)
- AF oscillator

•@

[TOP](#) [PREVIOUS](#) [NEXT](#)

10.2 Output Voltage Adjustment

[TOP](#) [PREVIOUS](#) [NEXT](#)

1. Turn on the power.
2. Select the input source to CD.
3. Connect the measuring instrument as shown in [Fig.2](#)
4. Apply 1 kHz, 200 mV signal to CD terminal.
5. Adjust the VOLUME to maximum.
6. Adjust **VR311** (L ch) and **VR312** (R ch) so that the output voltage to AC 1.00 V \pm 0.2 dB. Shown in [Fig.3](#)

Fig.2

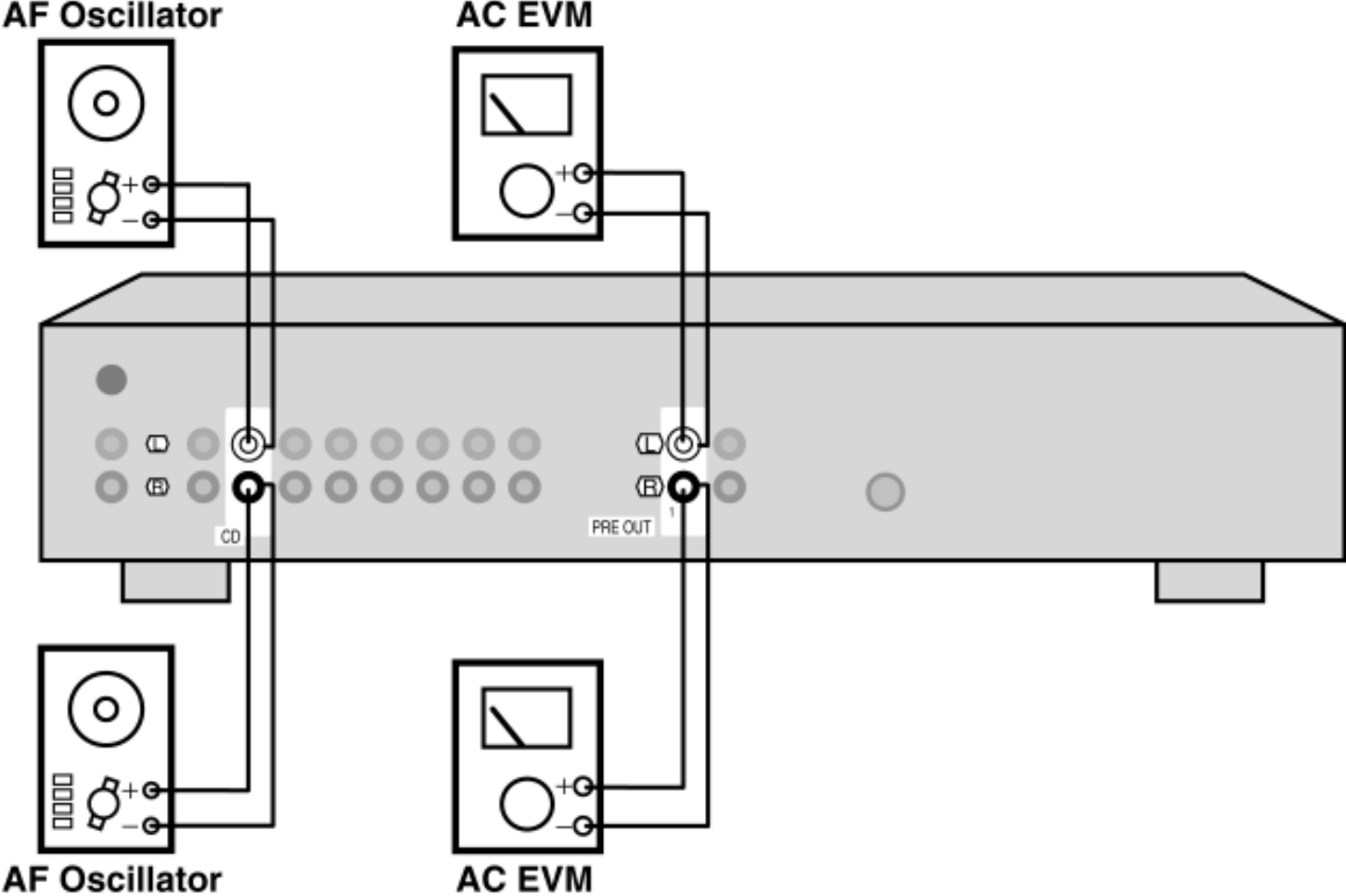

- [Adjustment Point](#)

Fig.3

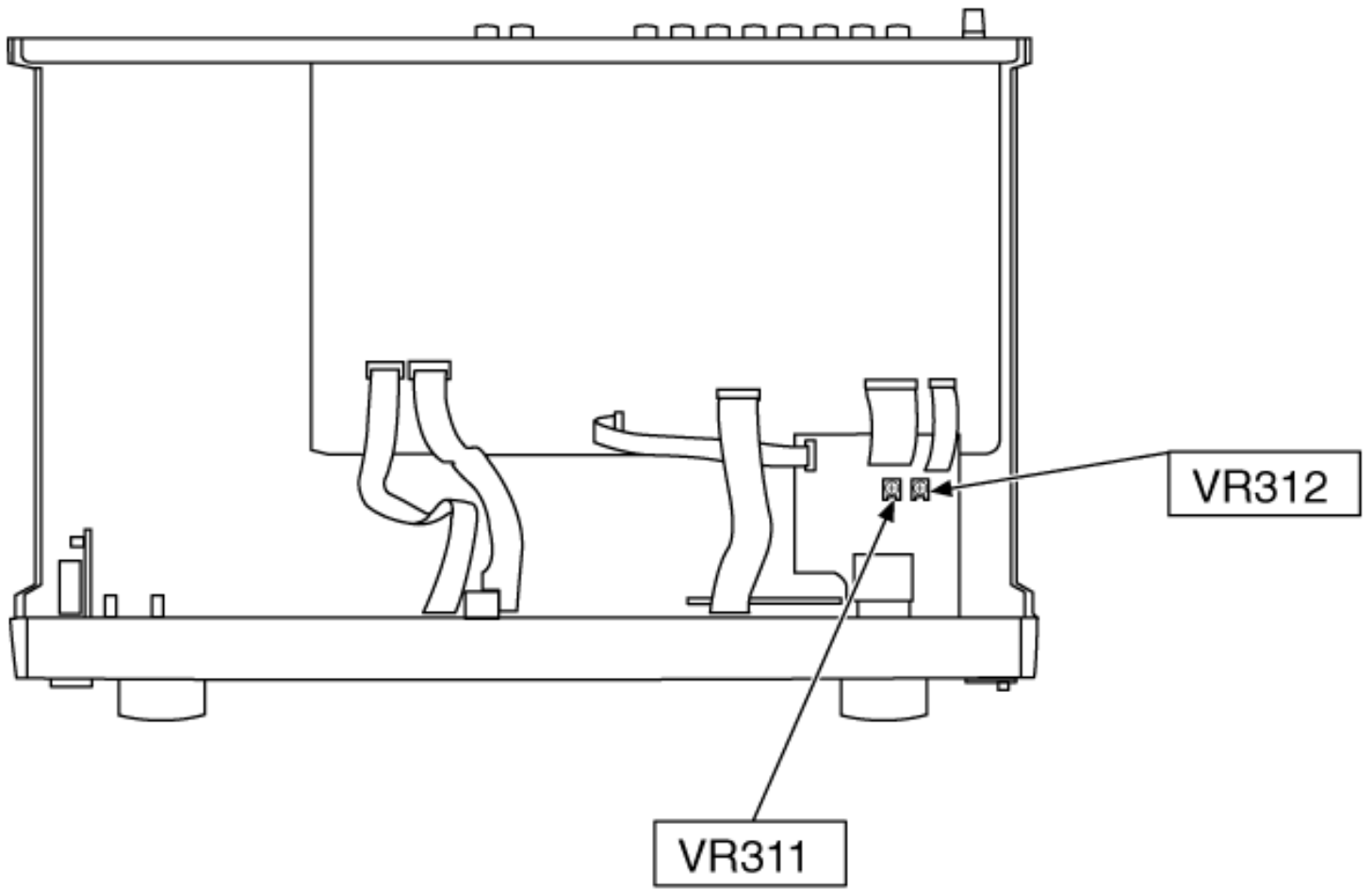

•@

[TOP](#) [PREVIOUS](#) [NEXT](#)

11 Terminal Function of ICs

[TOP](#) [PREVIOUS](#) [NEXT](#)

[11.1 IC701 \(M38503M2404F\) : Micro Computer](#)

•@

[TOP](#) [PREVIOUS](#) [NEXT](#)

11.1 IC701 (M38503M2404F) : Micro Computer

[TOP](#) [PREVIOUS](#) [NEXT](#)

Pin No.	Name	I/O	Function
1	VCC	I	Power supply (+5 V) terminal
2	VREF	I	Reference voltage input
3	AGND	-	GND terminal
4	CS	I	Chip select signal input
5	NC	-	Not used, open
6	REMCON	I	Remote control signal input
7	BACKUP	I	Power failure detect signal input
8	NC	-	Not used, open
9	SELDATA	O	Data signal output for input select IC (IC201 and IC202)
10	SELCLK	O	Clock signal output for input select IC (IC201 and IC202)
11	SELSTB	O	Strobe signal output for input select IC (IC201 and IC202)
12	POWERSW	I	Selector switch (S804) detect signal input
13	LEDCLK	O	Clock signal output for LED drive IC
14	LEDDATA	O	Data signal output for LED drive IC
15	CNVSS	-	Connected to GND
16	VRDOWN	O	Motor drive signal output (Volume down)
17	VRUP	O	Motor drive signal output (Volume up)
18	RESET	I	System reset signal input
19	XIN	I	Connected to the ceramic oscillator (8 MHz)
20	XOUT	O	Connected to the ceramic oscillator (8 MHz)
21	GND	-	GND terminal
22	BATELED	-	Battery level (empty) LED (D809) drive signal output (Not used, open)
23	BATFLED	-	Battery level (full) LED (D809) drive signal output (Not used, open)
24	VIALED	O	VIA LED drive signal output
25	VGALED	O	VGCA LED drive signal output
26	STABYLED	O	Stand by LED drive signal output
27	FRNTOUT	O	Front output control signal output
28	CSWSOUT	-	Center/S.woofer/Surround output control signal output (Not used, open)
29	PWRRLY	O	Power control signal output
30	CHRGRLY	-	Battery charge relay control signal output (Not used, open)
31	BATRLY	-	Battery drive relay control signal output (Not used, open)

32	VGARLY	O	VGCA mode relay control signal output
33 36	NC	-	Not used, open
37	SELPH	-	Not used, open
38	BATLVL2	-	Battery voltage detection (2) signal input (Not used, open)
39	NC	-	Not used, open
40	RSWAD	I	Power switch (S805) detect signal input
41	KEYAD	I	Tape monitor and VGCA switch input
42	BATLVL1	-	Battery voltage detection (1) signal input (Not used, open)

•@

[TOP](#) [PREVIOUS](#) [NEXT](#)

12 Replacement Parts List

[TOP](#) [PREVIOUS](#) [NEXT](#)

Notes:

- Important safety notice:

Components identified by  mark have special characteristics important for safety.

Furthermore, special parts which have purposes of fire-retardant (resistors), high-quality sound (capacitors), low-noise (resistors), etc. are used.



When replacing any of components, be sure to use only manufactures specified parts shown in the parts list.





- The marking (RTL) indicates that Retention Time is Limited for this item. After the discontinuation of this assembly in production, the item will continue to be available for a specific period of time. The retention period of availability is dependent on the type of assembly, and in accordance with the laws governing part and product retention. After the end of this period, the assembly will no longer be available.
- All parts are supplied by MESA.



Ref. No.	Part No.	Part Name& Description	Pcs.	Remarks
1	RKM0078-1K	TOP CABINET	1	
2	RHD30035-K1	SCREW	4	
3	XTBS3+8JFZ1	SCREW	2	
4	RGW0229-K	KNOB,SELECTOR	1	
5	RGW0230-K	KNOB,VOLUME	1	
6	RKA0053-A	FOOT	4	
6-1	RMG0270-K	RUBBER	4	
7	RDG0449	GEAR	2	
8	RGB0031-A	TECHNICS BADGE	1	
9	RGB0112-N	VGCA BADGE	1	
10	RGG0168C-K	PANEL	1	
11	RGK0747-S	RING ORNAMENT	2	

<u>12</u>	RGK1111-K	NUT	4	
<u>13</u>	RGK1163-K	DISPLAY 1	1	
<u>14</u>	RGK1164A-K1	DISPLAY 2	1	
<u>15</u>	RGL0453-Q	PANEL LIGHT 1	2	
<u>16</u>	RGL0454-Q	PANEL LIGHT 2	2	
<u>17</u>	RGP0740A-K	SUB GRILL	1	
<u>18</u>	RGP0743-K	GRILL	1	
<u>19</u>	RGU0890-1K	BUTTON,POWER	1	
<u>20</u>	RGU1712-K	BUTTON,OPEN	1	
<u>21</u>	RGU1774-S	BUTTON,VGCA	1	
<u>22</u>	RGW0205-S	KNOB,	3	
<u>23</u>	RHD26033	SCREW	4	
<u>24</u>	RHD26034	SCREW	3	
<u>25</u>	RHN90001	NUT	2	
<u>26</u>	RKF0593-Q	DOOR	1	
<u>27</u>	RKG0009	MAGNET	1	
<u>28</u>	RKW0273A-K	FILTER	1	
<u>29</u>	RME0284	SPRING	1	
<u>30</u>	RMR1202-K	ARM(L)	1	
<u>31</u>	RMR1203-K	ARM(R)	1	
<u>32</u>	RMR1204-K	MAGNET HOLDER	1	
<u>33</u>	RMR1205-K	DAMPER HOLDER	2	
<u>34</u>	RMR1206-K	DAMPER(R)	1	
<u>35</u>	RMR1207-K	DAMPER(L)	1	
<u>36</u>	XTBS26+8J	SCREW	20	
<u>37</u>	XTS2+4GFZ	SCREW	4	
<u>38</u>	SNE2123	SCREW	1	
<u>39</u>	XTBS3+8JFZ1	SCREW	10	
<u>40</u>	XTB3+20JFZ	SCREW	5	
<u>41</u>	XTB3+6JFZ	SCREW	3	
C101,02	ECBT1H221KB5	50V 220P	2	
C103,04	ECA1HPXS4R7B	50V 4.7U	2	
C107,08	RCE1AKA330BG	10V 33U	2	

C113,14	ECQB1H682JF3	50V 6800P	2	
C115,16	ECQB1H223JF3	50V 0.022U	2	
C117,18	ECEA1VKA4R7B	35V 4.7U	2	
C119,20	ECQB1H472JF3	50V 4700P	2	
C121,22	ECKR1H103ZF5	50V 0.01U	2	
C123,24	ECBT1H102KB5	50V 1000P	2	
C201,02	ECBT1H101KB5	50V 100P	2	
C203-06	ECCR1H101K5	50V 100P	4	
C211,12	ECBT1H101KB5	50V 100P	2	
C215	ECBT1H101KB5	50V 100P	1	
C217,18	ECBT1C103NS5	16V 0.01U	2	
C219,20	ECA1HPXS4R7B	50V 4.7U	2	
C221	ECBT1H101KB5	50V 100P	1	
C223,24	ECBT1C103NS5	16V 0.01U	2	
C225,26	ECA1HPXS4R7B	50V 4.7U	2	
C231	ECBT1E103ZF	25V 0.01U	1	
C251-58	ECBT1H101KB5	50V 100P	8	
C301,02	ECBT1H181KB5	50V 180P	2	
C303,04	ECBT1E103ZF	25V 0.01U	2	
C305,06	ECA1EPXS100B	25V 10U	2	
C351,52	ECA1EPXS100B	25V 10U	2	
C353,54	ECCR1H101K5	50V 100P	2	
C355,56	ECA1APXS221	10V 220U	2	
C357,58	ECBT1H820KB5	50V 82P	2	
C359,60	ECBT1H390J5	50V 39P	2	
C361,62	ECA1HPXS3R3	50V 3.3U	2	
C363,64	ECBT1E103ZF	25V 0.01U	2	
C367,68	ECA1EPXS220B	25V 22U	2	
C391,92	ECEA0JKS101	6.3V 100U	2	
C393,94	ECFR1E104ZF5	25V 0.1U	2	
C401,02	ECEA1HKS010	50V 1U	2	
C403-06	ECBT1H101KB5	50V 100P	4	
C407,08	ECBT1H560J5	50V 56P	2	
C409,10	RCE1CKA470BG	16V 47U	2	
C411,12	ECBT1E103ZF	25V 0.01U	2	
C415,16	ECBT1C222KR5	16V 2200P	2	
C417,18	ECBT0J153MS5	6.3V 0.015U	2	

C419,20	ECBT1C332KR5	16V 3300P	2	
C421,22	ECQV1H823JZ	50V 0.082U	2	
C423,24	ECBT0J153MS5	6.3V 0.015U	2	
C425,26	ECBT1H121KB5	50V 120P	2	
C427,28	ECEA1HKS010	50V 1U	2	
C513,14	ECEA1HPS010	50V 1U	2	
C515,16	ECCR1H101J5	50V 100P	2	
C519,20	ECA1EPXS100B	25V 10U	2	
C521,22	ECA1CPXS470B	16V 47U	2	
C523,24	ECCR1H331J5	50V 330P	2	
C601	ECEA1HKS010	50V 1U	1	
C607,08	ECA1EPXS470B	25V 47U	2	
C651	ECA1EM222	25V 2200U	1	
C655	RCE1CKA470BG	16V 47U	1	
C656	ECQV1H104JM3	50V 0.1U	1	
C658	ECBT1C103NS5	16V 0.01U	1	
C701,02	ECA0JM102	6.3V 1000U	2	
C703	RCE1HKAR47BG	50V 0.47U	1	
C704	ECEA1HKS2R2	50V 2.2U	1	
C705,06	ECBT1C103NS5	16V 0.01U	2	
C707,08	RCE1HKAR22BG	50V 0.22U	2	
C709	ECBT1C103NS5	16V 0.01U	1	
C801	ECEA0JKS101	6.3V 100U	1	
C802	ECBT1E103ZF	25V 0.01U	1	
C803	ECBT1H104ZF5	50V 0.1U	1	
C804,05	ECBT1H101KB5	50V 100P	2	
C806	ECBT1H104ZF5	50V 0.1U	1	
CN301	RJS1A6604	CONNECTOR(4P)	1	
CN302	RJS1A6607T1	CONNECTOR(7P)	1	
CN303	RJS1A6604	CONNECTOR(4P)	1	
CN401	RJS1A6607T1	CONNECTOR(7P)	1	
CN701	RJS7T4ZA	CONNECTOR(7P)	1	
CN702	RJS8T4ZA	CONNECTOR(8P)	1	
D201,02	MA165	DIODE	2	
D501	MA165	DIODE	1	

D521	MA165	DIODE	1	
D601	MA165	DIODE	1	
D607	MA165	DIODE	1	
D651-54	RL1N4003N02	DIODE	4	
D655,56	MA167	DIODE	2	
D658	MA4056M	DIODE	1	
D701	1SS291TA	DIODE	1	
D702	MA165	DIODE	1	
D704	1SS291TA	DIODE	1	
D705-07	MA165	DIODE	3	
D709,10	MA165	DIODE	2	
D712	MA165	DIODE	1	
D801-04	SLR325VCT31	LED	4	
D806-08	SLR325VCT31	LED	3	
D811	SLR325DCT31	LED	1	
D812,13	SLR325VCT31	LED	2	
D814,15	SLR325DCT31	LED	2	
D816-18	SLR325VCT31	LED	3	
IC101	AN6558F	IC	1	
IC201	TC9163N	IC	1	
IC202	TC9164N	IC	1	
IC311	UPC4570C	IC	1	
IC351	UPC4570C	IC	1	
IC391	BA6218	IC	1	
IC401	NJM4580EDTE1	IC	1	
IC511	UPC4570C	IC	1	
IC601	M5F78M05L	IC	1	
IC701	M38503M2404F	IC	1	
IC801	BU2090AFE2	IC	1	
JK201	SJF3069-11N	JACK,PHONO	1	
JK202-05	SJF3069N	JACK,IN/OUT	4	
JK501	SJF3069N	JACK,PRE/OUT	1	
JK801	RJS1D0706	JACK(7P)	1	
L391,92	ELEXT1R0KA9	COIL	2	

L601-07	ELEXT1R0KA9	COIL	7	
L701	ELEXT101KA9	COIL	1	
L801	ELEXT101KA9	COIL	1	
L802	ELEXT100KA9	COIL	1	
<u>P1</u>	RPG4512	PACKING CASE	1	
<u>P2</u>	RPN1206	PAD	1	
<u>P3</u>	SPP756	PROTECTION COVER	1	
PCB1	REP2873A-M	MAIN PCB	1	(RTL)
PCB2	REP2841D-S	PANEL PCB	1	(RTL)
Q201	DTC124EST	TRANSISTOR	1	
Q202	DTA124ESTP	TRANSISTOR	1	
Q203	DTC124EST	TRANSISTOR	1	
Q204	DTA124ESTP	TRANSISTOR	1	
Q501	DTA124ESTP	TRANSISTOR	1	
Q502	DTC124EST	TRANSISTOR	1	
Q521	DTC124EST	TRANSISTOR	1	
Q522	DTA124ESTP	TRANSISTOR	1	
Q601,02	DTA124ESTP	TRANSISTOR	2	
Q603	DTC144ESTP	TRANSISTOR	1	
Q701	DTC114ESTP	TRANSISTOR	1	
Q702	DTC114YSTP	TRANSISTOR	1	
Q710	DTC114YSTP	TRANSISTOR	1	
R101,02	ERDS2FJ152	1/4W 1.5K	2	
R103,04	ERDS2FJ224	1/4W 220K	2	
R105,06	ERDS2FJ563	1/4W 56K	2	
R117,18	ERDS2FJ181	1/4W 180	2	
R123,24	ERDS2FJ680	1/4W 68	2	
R125,26	ERDS2FJ123	1/4W 12K	2	
R127,28	ERDS2FJ184	1/4W 180K	2	
R129,30	ERDS2FJ563	1/4W 56K	2	
R131,32	ERDS2FJ102	1/4W 1K	2	
R201-06	ERDS2FJ102	1/4W 1K	6	
R211,12	ERDS2FJ102	1/4W 1K	2	

R215-17	ERDS2FJ103	1/4W 10K	3	
R219-21	ERDS2FJ103	1/4W 10K	3	
R222,23	ERDS2FJ102	1/4W 1K	2	
R224	ERDS2FJ472	1/4W 4.7K	1	
R227	ERDS2FJ472	1/4W 4.7K	1	
R251-58	ERDS2FJ102	1/4W 1K	8	
R301,02	ERDS2FJ104	1/4W 100K	2	
R315,16	ERDS2FJ272	1/4W 2.7K	2	
R351,52	ERDS2FJ102	1/4W 1K	2	
R353,54	ERDS2FJ333	1/4W 33K	2	
R355,56	ERDS2FJ272	1/4W 2.7K	2	
R357,58	ERDS2FJ224	1/4W 220K	2	
R361,62	ERDS2FJ183	1/4W 18K	2	
R363,64	ERDS2FJ103	1/4W 10K	2	
R365,66	ERDS2FJ102	1/4W 1K	2	
R391	ERDS1FJ100	1/2W 10	1	
R401,02	ERDS2FJ472	1/4W 4.7K	2	
R403-06	ERDS2FJ224	1/4W 220K	4	
R407,08	ERDS2FJ392	1/4W 3.9K	2	
R409,10	ERDS2FJ102	1/4W 1K	2	
R411,12	ERDS2FJ183	1/4W 18K	2	
R413,14	ERDS2FJ392	1/4W 3.9K	2	
R415-18	ERDS2FJ223	1/4W 22K	4	
R503,04	ERDS2FJ332	1/4W 3.3K	2	
R513,14	ERDS2FJ104	1/4W 100K	2	
R515,16	ERDS2FJ224	1/4W 220K	2	
R521,22	ERDS2FJ331	1/4W 330	2	
R523,24	ERDS2FJ473	1/4W 47K	2	
R525,26	ERDS2FJ101	1/4W 100	2	
R655,56	ERDS2FJ103	1/4W 10K	2	
R701	ERDS2FJ681	1/4W 680	1	
R702,03	ERDS2FJ103	1/4W 10K	2	
R704,05	ERDS2FJ104	1/4W 100K	2	
R706	ERDS2FJ103	1/4W 10K	1	
R707-09	ERDS2FJ104	1/4W 100K	3	
R710	ERDS2FJ103	1/4W 10K	1	
R723-25	ERDS2FJ103	1/4W 10K	3	

R726	ERDS2FJ102	1/4W 1K	1	
R728	ERDS2FJ104	1/4W 100K	1	
R801	ERDS2FJ821	1/4W 820	1	
R802	ERDS2FJ102	1/4W 1K	1	
R803	ERDS2FJ122	1/4W 1.2K	1	
R804	ERDS2FJ152	1/4W 1.5K	1	
R805	ERDS2FJ182	1/4W 1.8K	1	
R806	ERDS2FJ222	1/4W 2.2K	1	
R807	ERDS2FJ332	1/4W 3.3K	1	
R808	ERDS2FJ472	1/4W 4.7K	1	
R809	ERDS2FJ682	1/4W 6.8K	1	
R810	ERDS2FJ123	1/4W 12K	1	
R811	ERDS2FJ223	1/4W 22K	1	
R812	ERDS2FJ561	1/4W 560	1	
R813,14	ERDS2FJ181	1/4W 180	2	
R815	ERDS2FJ331	1/4W 330	1	
R819	ERDS2FJ271	1/4W 270	1	
R820	ERDS2FJ223	1/4W 22K	1	
R821	ERDS2FJ123	1/4W 12K	1	
R822	ERDS2FJ331	1/4W 330	1	
R823	ERDS2FJ181	1/4W 180	1	
R824,25	ERDS2FJ331	1/4W 330	2	
R826,27	ERDS2FJ101	1/4W 100	2	
R828,29	ERDS2FJ103	1/4W 10K	2	
R830	ERDS2FJ331	1/4W 330	1	
RL201 ,02	RSY0020M-R	RELAY	2	
RL501	RSY0020M-R	RELAY	1	
RL521	RSY0020M-R	RELAY	1	
S801,02	EVQ21405R	SW,PUSH	2	
S804	RSR9A001-A	SW,SELECTOR	1	
S805	RSP2B023-A	SW,UNIT ON/OFF	1	
TP1-P5	QJT1090	TEST POINT	5	
VR301	RRV16J05Z24A	VR,VOLUME	1	

VR311, 12	EVNDXAA00B23	VR,OUTPUT VOLT.ADJ.	2	
VR401	EVJ02QF01G15	VR,BALANCE	1	
VR402 ,03	EVJYA1F01C15	VR,BASS/TREBLE	2	
X701	RSXY8M00D01T	OSCILLATOR	1	
Z801	RCD12042TH	COMPONENT COMBINATION	1	

•@

[TOP](#) [PREVIOUS](#) [NEXT](#)

13 Cabinet Parts Location

[TOP](#) [PREVIOUS](#) [NEXT](#)



•@

[TOP](#) [PREVIOUS](#) [NEXT](#)

14 Packaging

[TOP PREVIOUS](#)



•@

[TOP PREVIOUS](#)

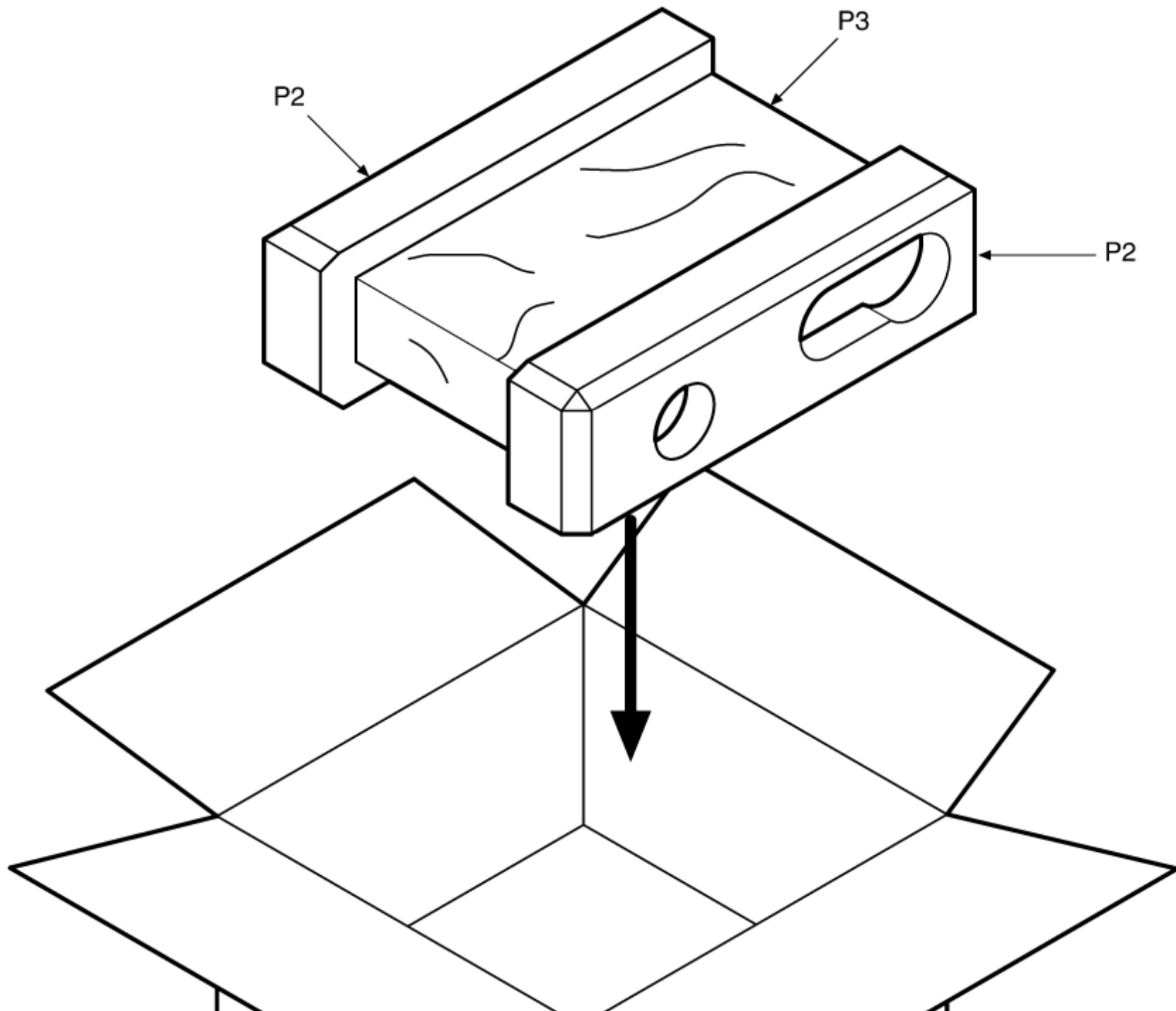

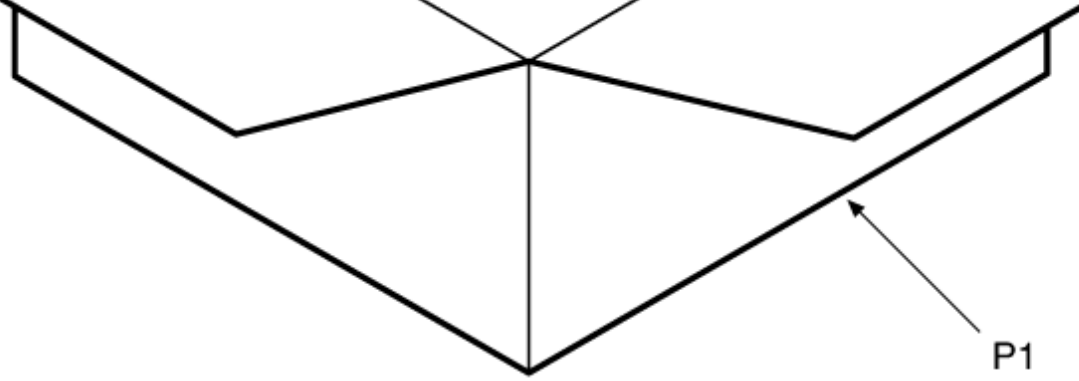

P1

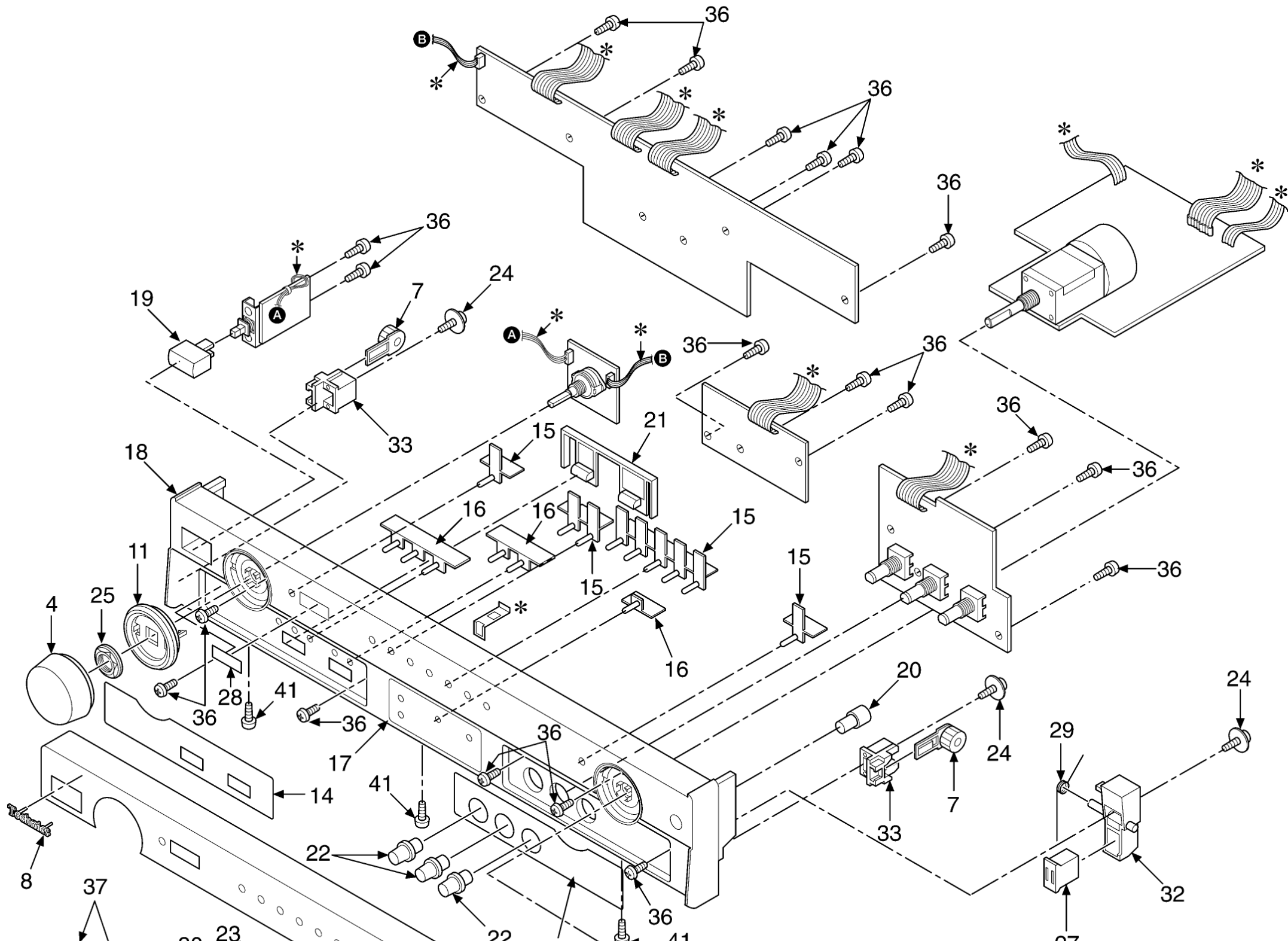

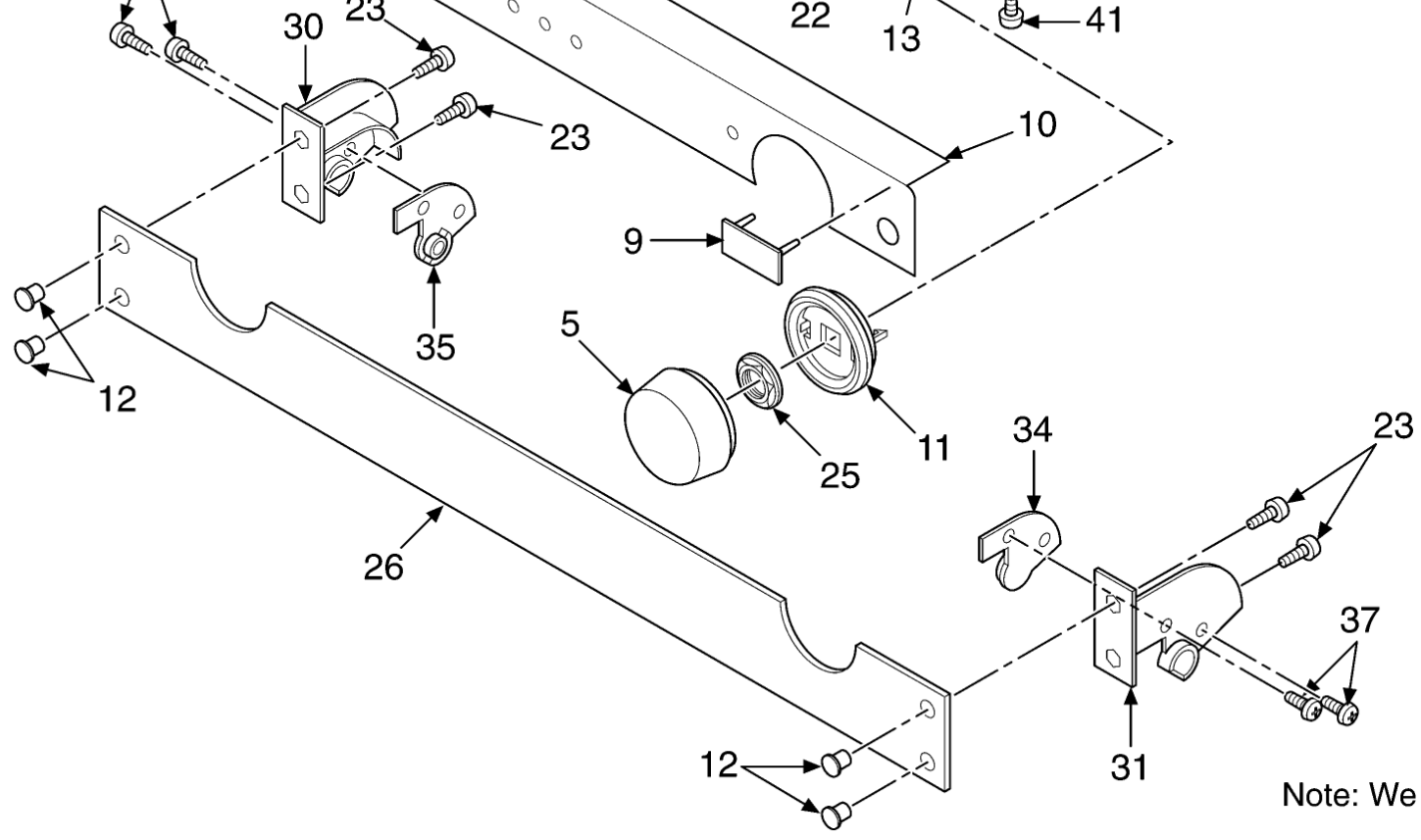

Note: We do not supply those items of parts marked *.

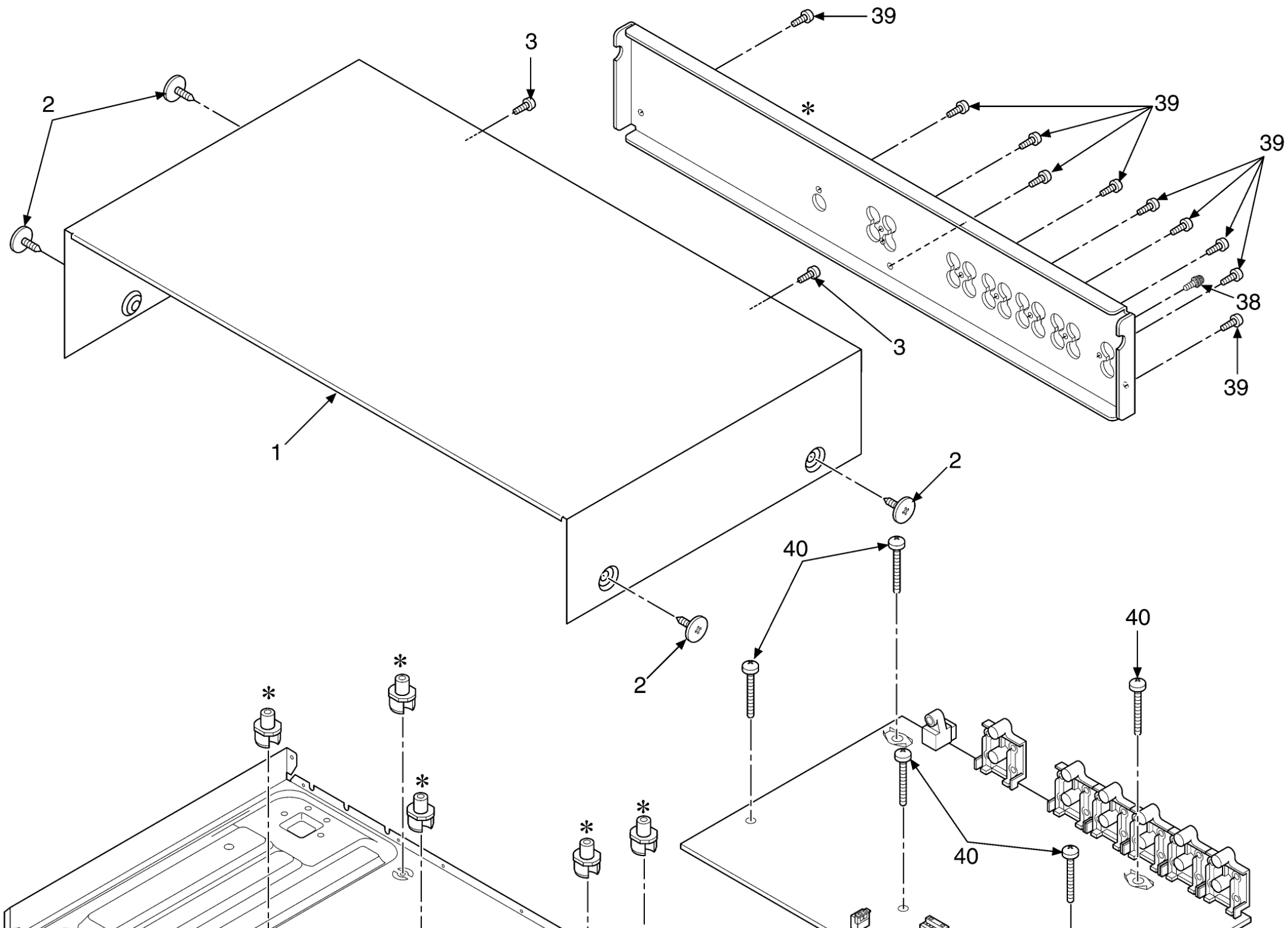

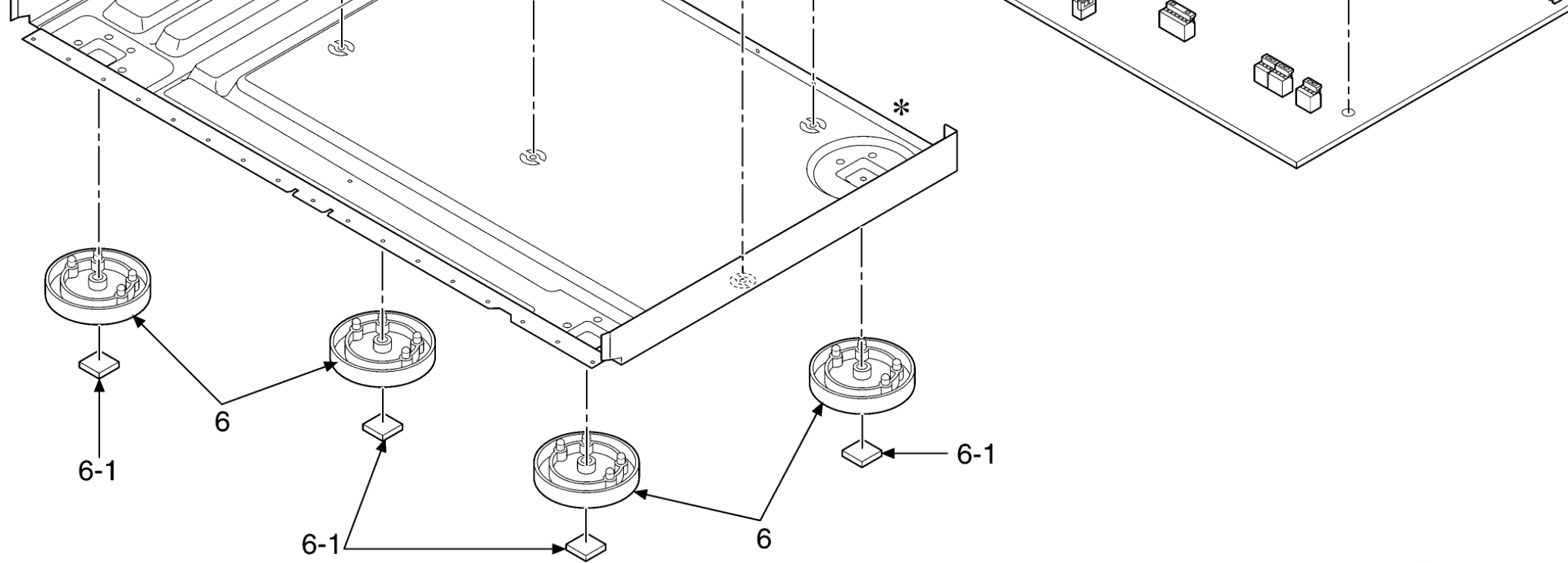

Note: We do not supply those items of parts marked*.

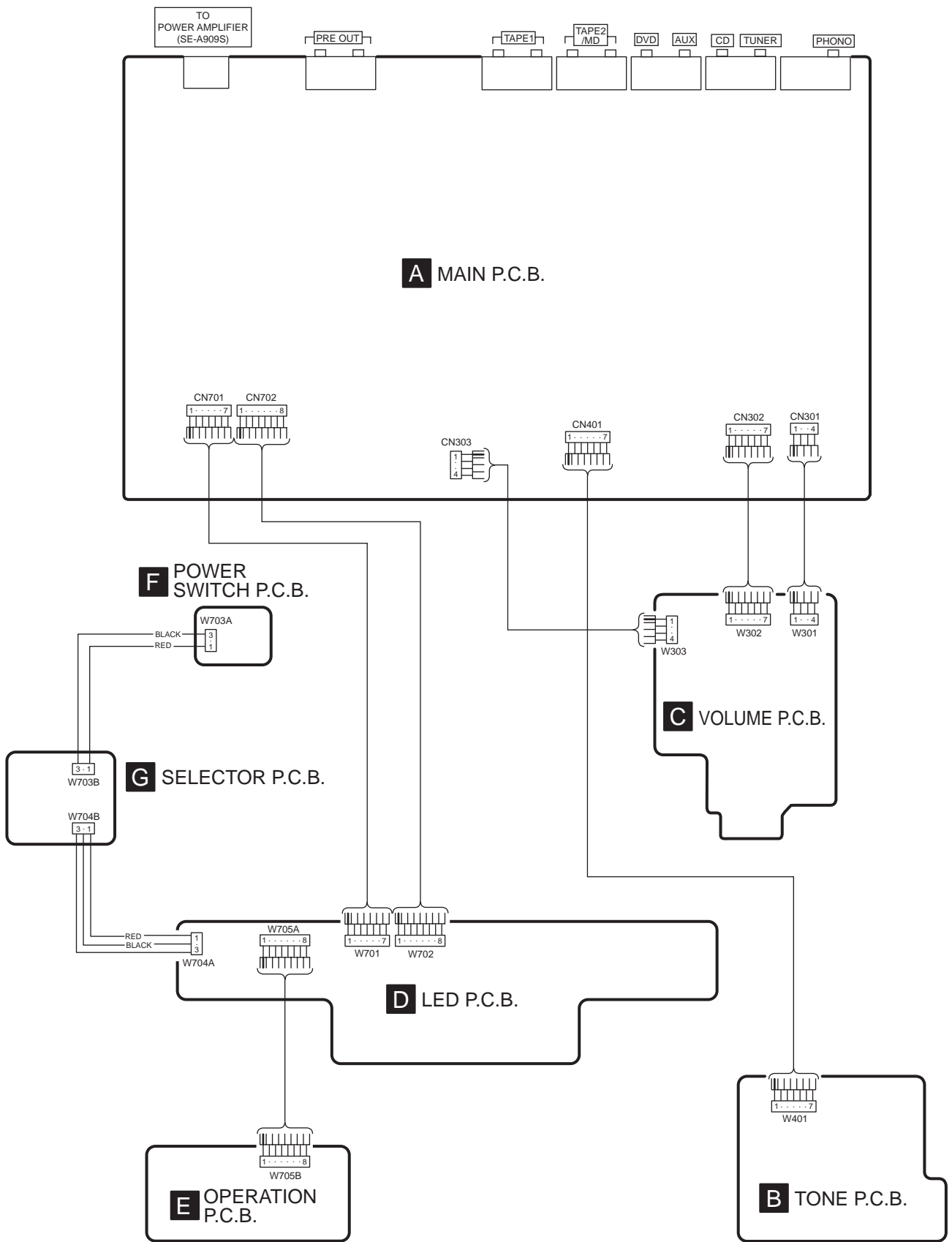

A MAIN P.C.B.

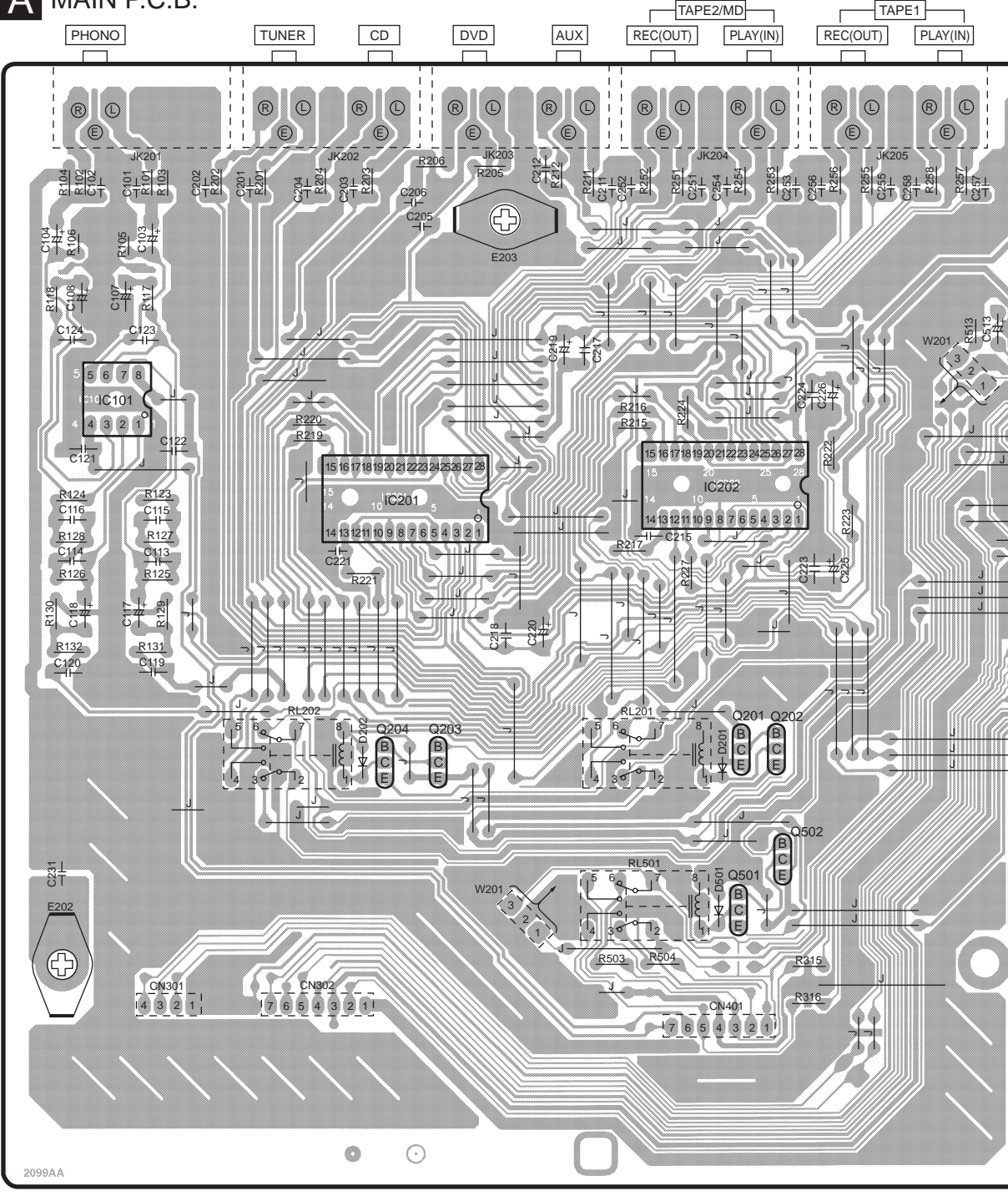

2099AA
(REP2873A-M)

G

H

I

J

K

L

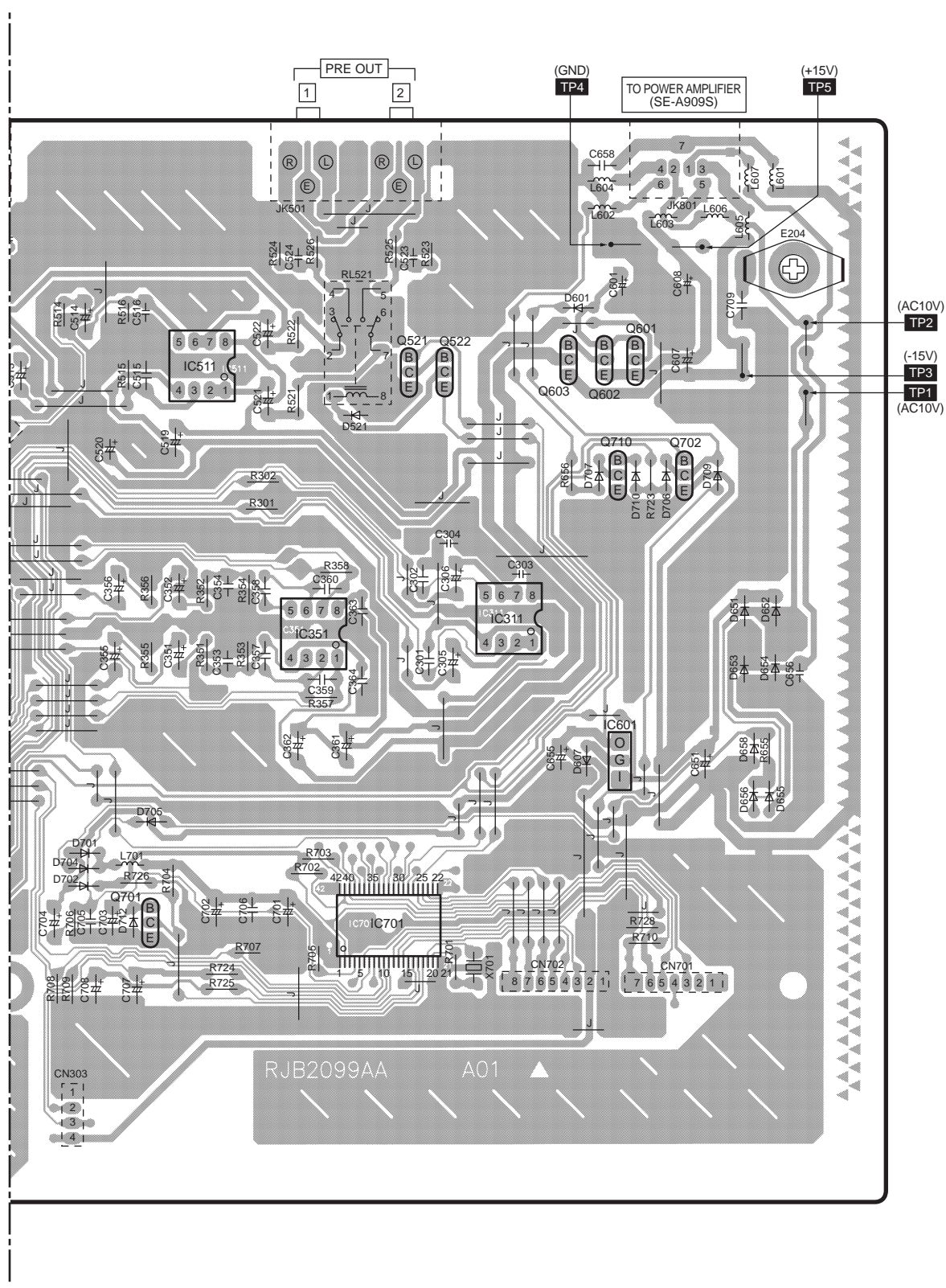

PRE OUT
1 2

(GND)
TP4

TO POWER AMPLIFIER
(SE-A909S)

(+15V)
TP5

(AC10V)
TP2

(-15V)
TP3

(AC10V)
TP1

RJB2099AA A01

■ ELECTRICAL PARTS LOCATION

Ref. No.	Lo. No.	Ref. No.	Lo. No.	Ref. No.	Lo. No.	Ref. No.	Lo. No.	Ref. No.	Lo. No.	Ref. No.	Lo. No.	Ref. No.	Lo. No.	Ref. No.	Lo. No.	Ref. No.	Lo. No.	Ref. No.	Lo. No.
A MAIN P.C.B.																			
IC101	3B	D601	3J	X701	6I	TP4	2J	R206	2C	R352	4H	R706	6G	C123	3B	C256	2E	C516	3G
IC201	4C	D607	5J	RL201	5E	TP5	2J	R211	2D	R353	4H	R707	6H	C124	3A	C257	2F	C519	3G
IC202	4E	D651	4K	RL202	5C	R101	2B	R212	2D	R354	4H	R708	6G	C201	2B	C258	2F	C520	3G
IC311	4I	D652	4K	RL501	6E	R102	2A	R215	3D	R355	4G	R709	6G	C202	2B	C301	5I	C521	3H
IC351	4H	D653	5K	RL521	3H	R103	2B	R216	3D	R356	4G	R710	6J	C203	2C	C302	4I	C522	3H
IC511	3H	D654	5K	CN301	7B	R104	2A	R217	4D	R357	5H	R723	4J	C204	2C	C303	4I	C523	2I
IC601	5J	D655	5K	CN302	7C	R104	3B	R219	4C	R358	4H	R724	6H	C205	2C	C304	4I	C524	2H
IC701	6I	D656	5K	CN303	7G	R105	2B	R220	3C	R503	6D	R725	6H	C206	2C	C305	5I	C601	2J
Q201	5E	D658	5K	CN401	7E	R106	2A	R221	4C	R504	6E	R726	6G	C211	2D	C306	4I	C607	3J
Q202	5E	D701	6G	CN701	6J	R117	3B	R222	4F	R513	3F	R728	6J	C212	2D	C351	4G	C608	2J
Q203	5C	D702	6G	CN702	6J	R118	3A	R223	4F	R514	3G	C101	2B	C215	4E	C352	4G	C651	5J
Q204	5C	D704	6G	JK201	2B	R123	4B	R224	3E	R515	3G	C102	2B	C217	3D	C353	5H	C655	5J
Q501	6E	D705	5G	JK202	2C	R124	4A	R227	4E	R516	3G	C103	2B	C218	5D	C354	4H	C656	5K
Q502	6E	D706	4J	JK203	2D	R125	4B	R251	2E	R521	3H	C104	2A	C219	3D	C355	5G	C658	2J
Q521	3I	D707	3J	JK204	2E	R126	4A	R252	2E	R522	6G	C107	3B	C220	5D	C356	4G	C701	6H
Q522	3I	D709	3J	JK205	2F	R127	4B	R253	2E	R523	2I	C108	3A	C221	4C	C357	4H	C702	6H
Q601	3J	D710	4J	JK501	2H	R128	4A	R254	2E	R524	2H	C113	4B	C223	4E	C358	4H	C703	6G
Q602	3J	D712	6G	JK801	2J	R129	4B	R255	2F	R525	2I	C114	4A	C224	3E	C359	5H	C704	6G
Q603	3J	L601	2K	E202	6A	R130	4A	R256	2F	R526	2H	C115	4B	C225	4F	C360	4H	C705	6G
Q701	6G	L602	2J	E203	2D	R131	5B	R257	2F	R655	5K	C116	4A	C226	3F	C361	5H	C706	6H
Q702	3J	L603	2J	E204	2K	R132	5A	R258	2F	R656	3J	C117	4B	C231	6A	C362	5H	C707	6G
Q710	3J	L604	2J	W201	6D	R201	2B	R301	4H	R701	6I	C118	4A	C251	2E	C363	4H	C708	6G
D201	5E	L605	2K	W201	3F	R202	2B	R302	4H	R702	6H	C119	5B	C252	2D	C364	5H	C709	3K
D202	5C	L606	2J	TP1	3K	R203	2C	R315	6E	R703	6H	C120	5A	C253	2E	C513	3F		
D501	6E	L607	2K	TP2	3K	R204	2C	R316	7E	R704	6G	C121	4A	C254	2E	C514	3G		
D521	3H	L701	6G	TP3	3K	R205	2D	R351	4H	R705	6H	C122	4B	C255	2F	C515	3G		

C VOLUME P.C.B.

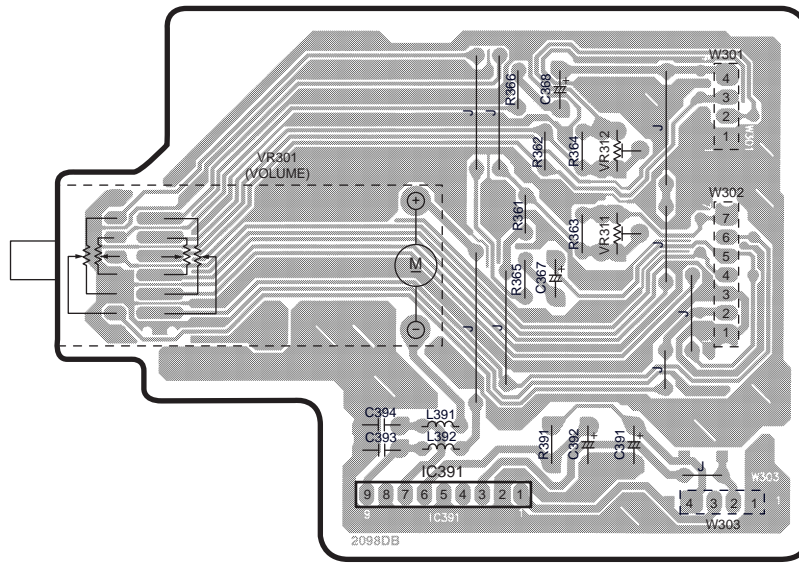

(REP2841D-S)

■ ELECTRICAL PARTS LOCATION

Ref. No.	Lo. No.	Ref. No.	Lo. No.
C VOLUME P.C.B.			
IC391	6C	R363	5C
VR301	5B	R364	5C
VR311	5D	R365	5C
VR312	5D	R366	4C
L391	6C	R391	6C
L392	6C	C367	5C
W301	4D	C368	4C
W302	5D	C391	6D
W303	6D	C392	6C
R361	5C	C393	6C
R362	5C	C394	6C
E OPERATION P.C.B.			
D811	8B	R813	7D
D812	8B	R814	7C
D813	8C	R815	7C
D814	8C	R820	8B
D815	8D	R821	8B
S801	8B	R822	7C
S802	8C	R823	7C
W705B	7B		

E OPERATION P.C.B.

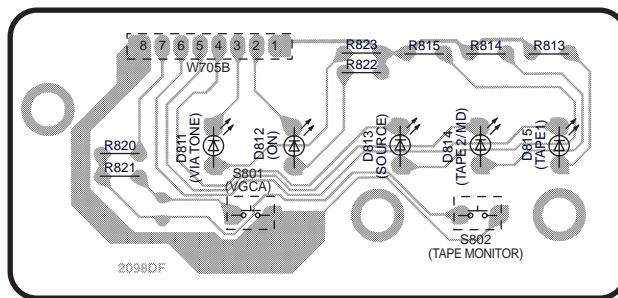

(REP2841D-S)

D LED P.C.B.

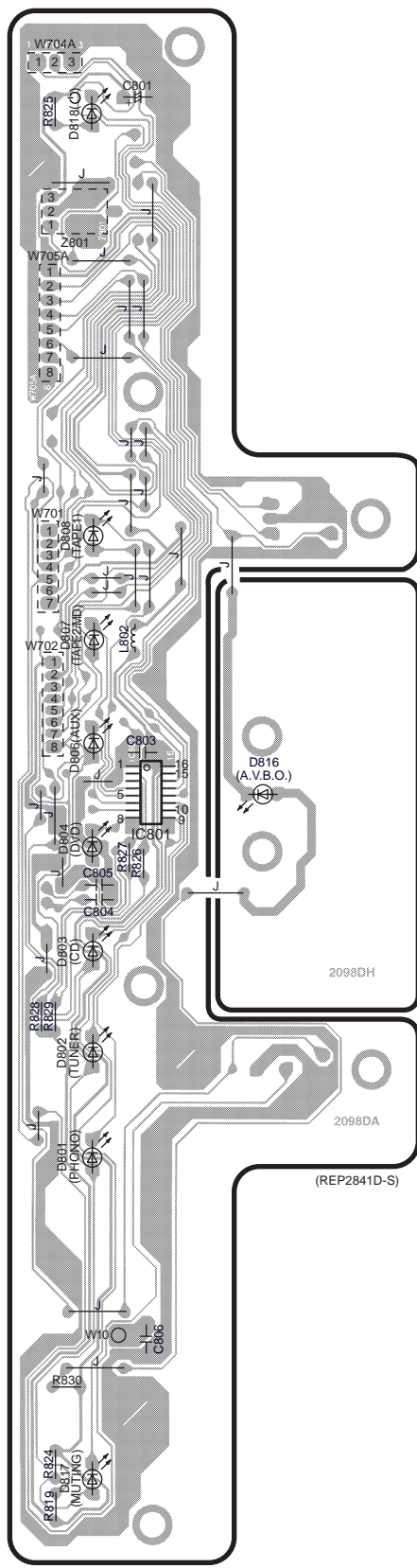

B TONE P.C.B.

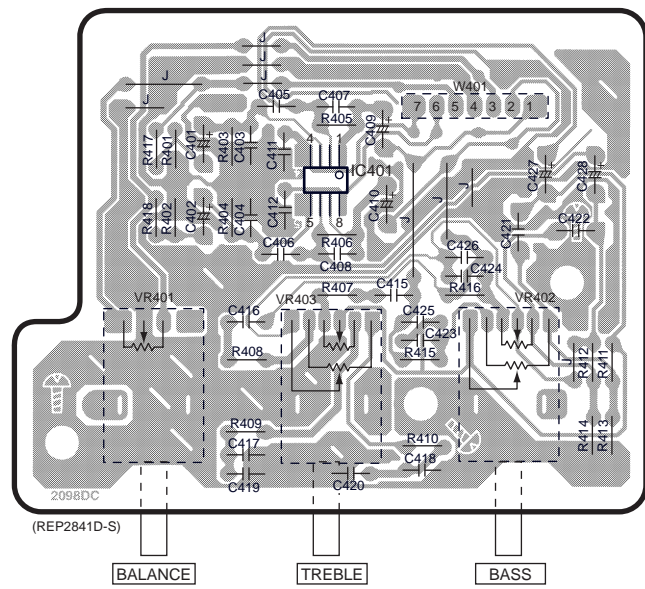

G SELECTOR P.C.B.

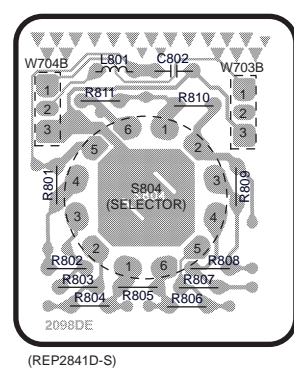

F POWER SWITCH P.C.B.

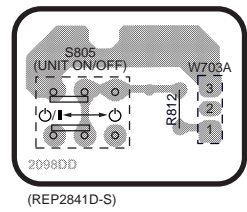

ELECTRICAL PARTS LOCATION

Ref. No.	Lo. No.	Ref. No.	Lo. No.	Ref. No.	Lo. No.	Ref. No.	Lo. No.	Ref. No.	Lo. No.
B TONE P.C.B.									
IC401	2E	R406	2E	R416	2E	C408	2E	C420	3E
VR401	3D	R407	2E	R417	2D	C409	2E	C421	2F
VR402	3F	R408	3D	R418	2D	C410	2E	C422	2F
VR403	3E	R409	3D	C401	2D	C411	2E	C423	2E
W401	1E	R410	3E	C402	2D	C412	2E	C424	2E
R401	2D	R411	3F	C403	2D	C415	2E	C425	2E
R402	2D	R412	3F	C404	2D	C416	2D	C426	2E
R403	2D	R413	3F	C405	1E	C417	3D	C427	2F
R404	2D	R414	3F	C406	2E	C418	3E	C428	2F
R405	1E	R415	3E	C407	1E	C419	3D		
D LED P.C.B.									
IC801	5B	D808	4A	W701	4A	R826	5A	C804	5A
D801	7A	D816	5B	W702	4A	R827	5A	C805	5A
D802	6A	D817	8A	W704A	1A	R828	6A	C806	7B
D803	6A	D818	2A	W705A	3A	R829	6A		
D804	5A	L802	4A	R819	8A	R830	8A		
D806	5A	Z801	2A	R824	8A	C801	1A		
D807	4A	W10	7A	R825	2A	C803	5B		
F POWER SWITCH P.C.B.									
S805	5D	W703A	5D	R812	5D				
G SELECTOR P.C.B.									
L801	4E	R801	5E	R805	5E	R809	5F		
S804	5E	R802	5E	R806	5F	R810	4F		
W703B	4F	R803	5E	R807	5F	R811	4E		
W704B	4F	R804	5E	R808	5F	C802	4F		

1
2
3
4
5
6
7
8

W704A
R825
D818
C801
Z801
W705A
W701
W702
L802
D806(AUX)
D806(CD)
IC801
R827
R826
C805
C804
R828
R829
D801 (PHONO)
D802 (TUNER)
D803 (CD)
W10
C806
R830
R819
R824 (MULTI)
D816 (A.V.B.O.)
2098DH
2098DA
(REP2841D-S)

W401
C405
C407
R417
R401
C401
R403
C403
IC401
C410
C409
R418
R402
C402
R404
C404
C412
C406
R406
C408
R407
C415
C426
C424
R416
VR402
C427
C428
C422
VR401
VR403
R408
C416
C425
C423
R415
R412
R411
R414
R413
R410
C418
C419
C420
2098DC
(REP2841D-S)
BALANCE
TREBLE
BASS

W704B
L801
C902
W703B
R811
R810
R801
R809
R802
R806
R803
R804
R805
R807
R808
S804 (SELECTOR)
2098DE
(REP2841D-S)

S805 (UNIT ON/OFF)
W703A
R812
2098DD
(REP2841D-S)

A MAIN CIRCUIT

→ : POSITIVE VOLTAGE LINE
⇨ : PHONO SIGNAL LINE
- - - : NEGATIVE VOLTAGE LINE
➡ : TAPE REC SIGNAL LINE

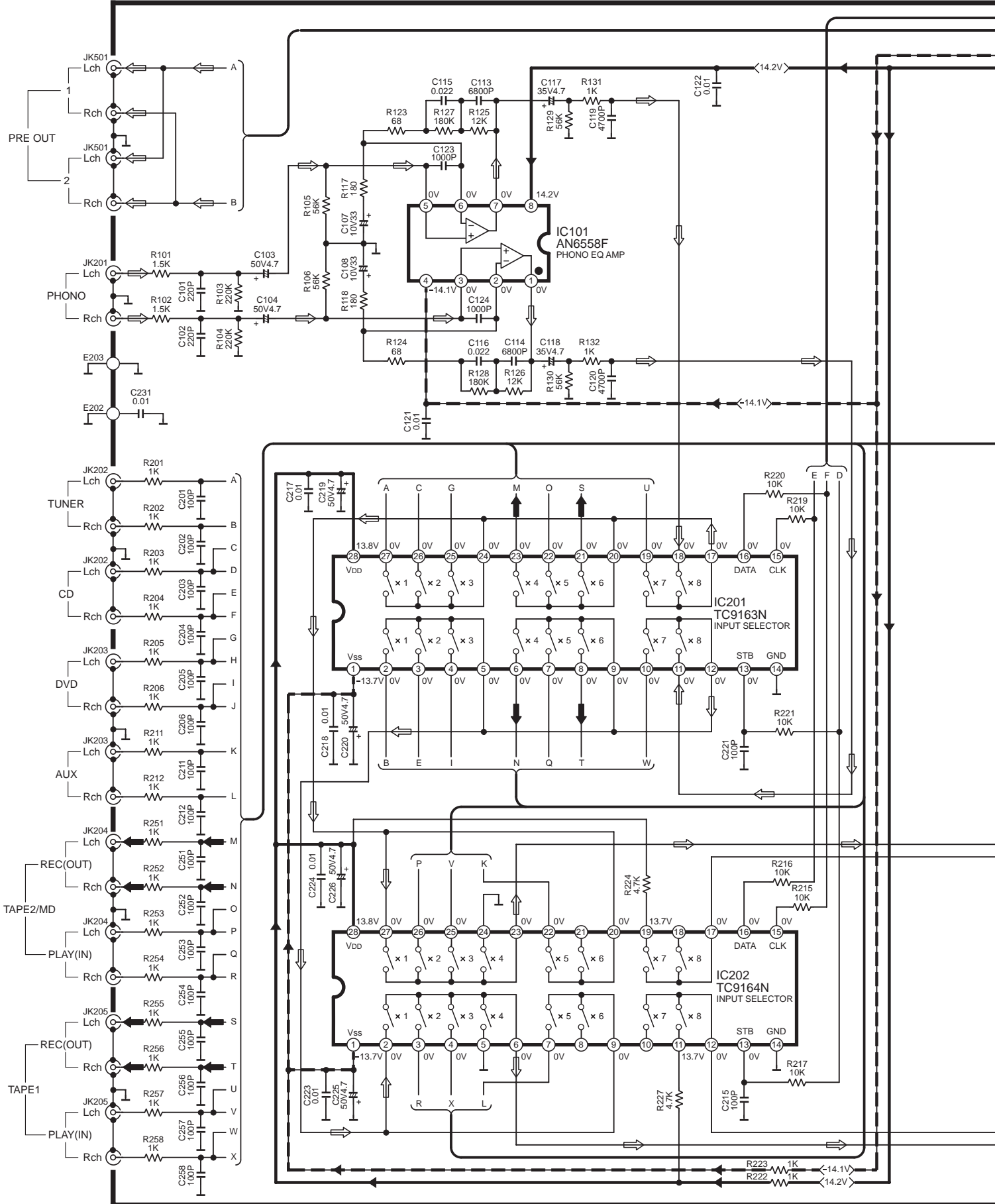

➔ : POSITIVE VOLTAGE LINE ➔➔ : NEGATIVE VOLTAGE LINE ⇨ : PHONO SIGNAL LINE

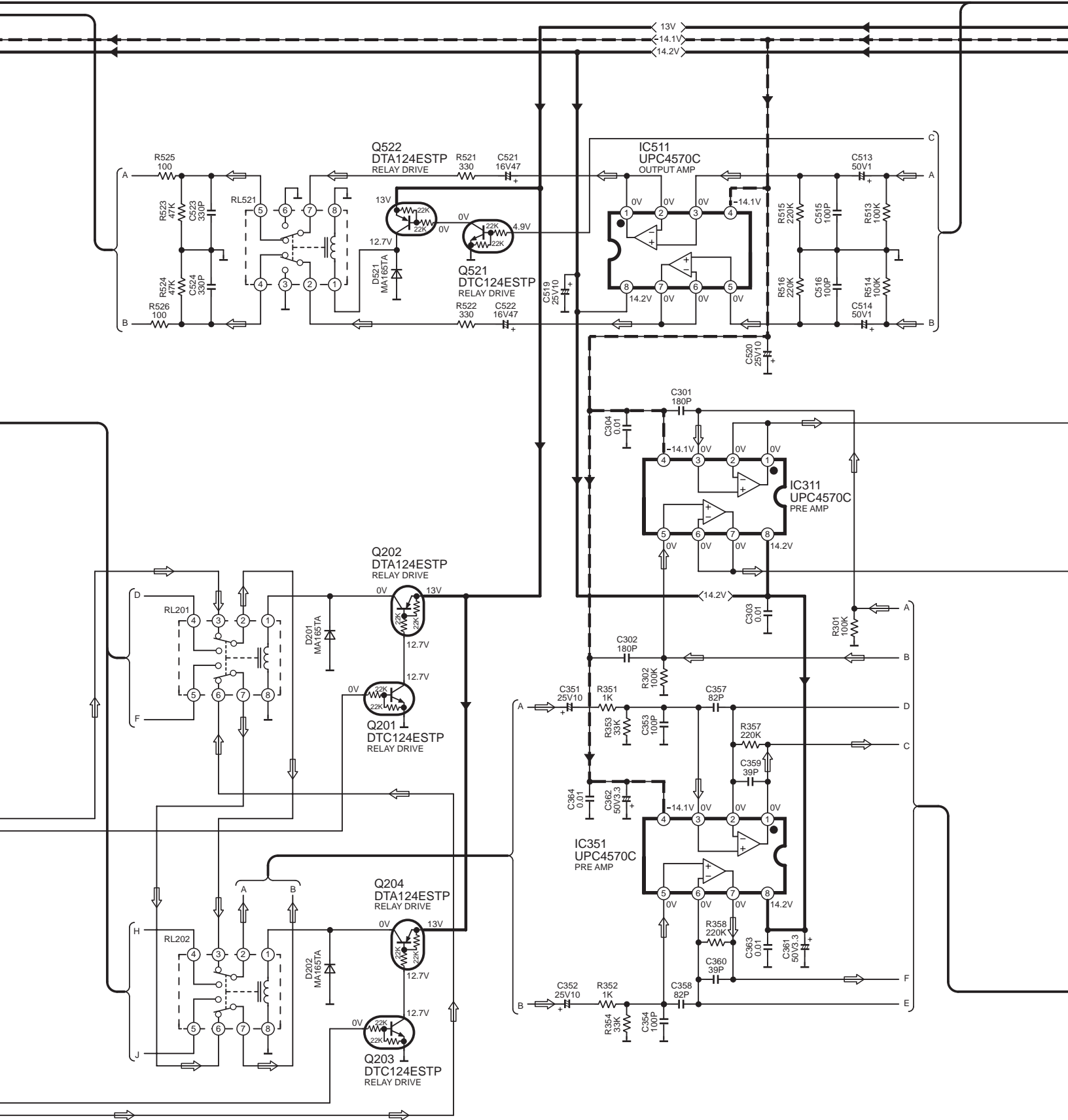

A MAIN CIRCUIT

→ : POSITIVE VOLTAGE LINE - - - -> : NEGATIVE VOLTAGE LINE ⇨ : PHONO SIGNAL LINE

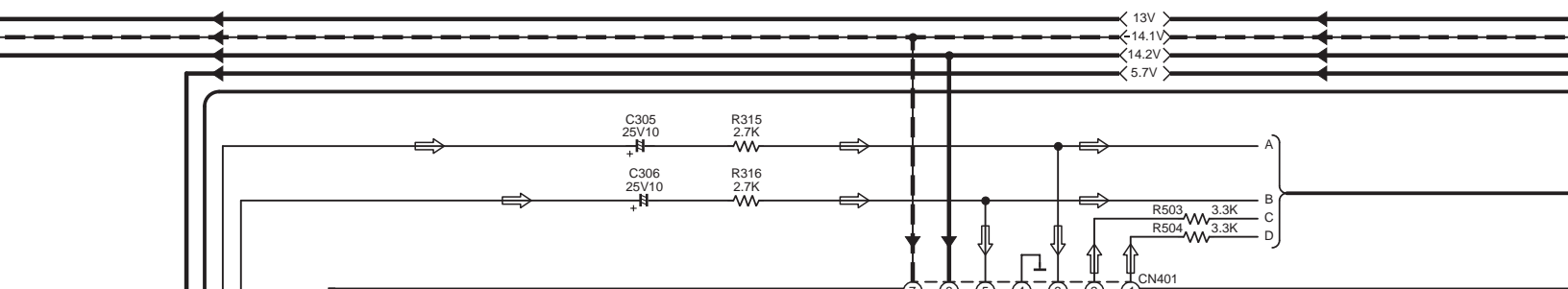

B TONE CIRCUIT

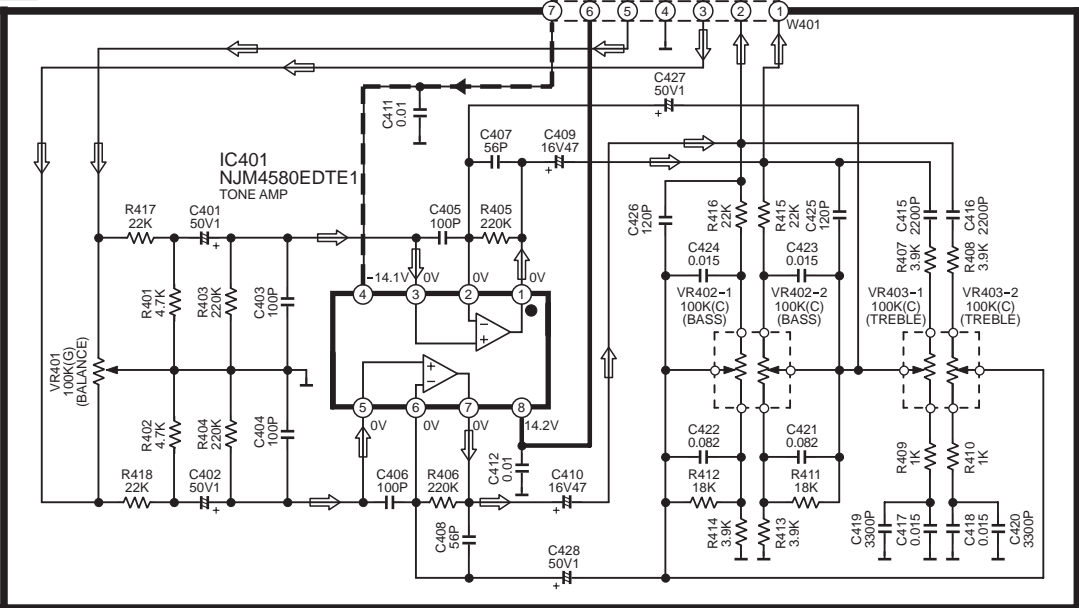

C VOLUME CIRCUIT

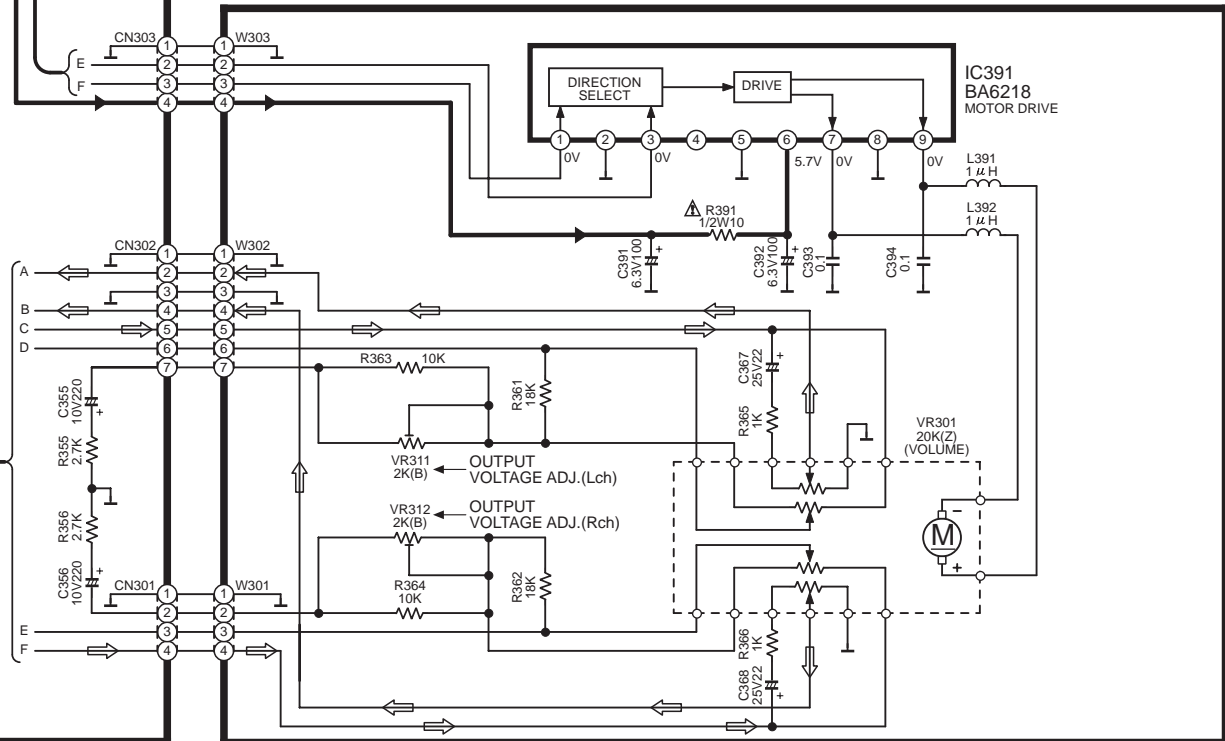

→ : POSITIVE VOLTAGE LINE - - - - - : NEGATIVE VOLTAGE LINE

13V
14.1V
14.2V
5.7V

D LED CIRCUIT

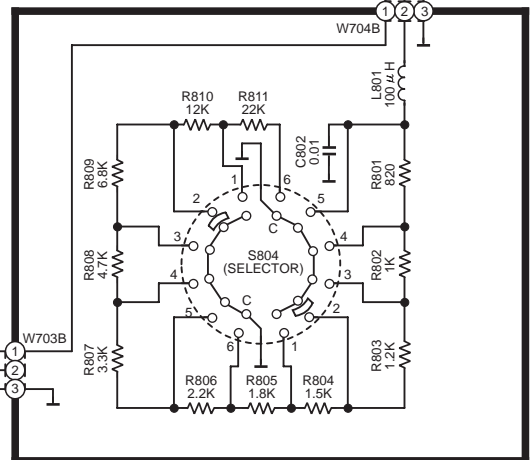
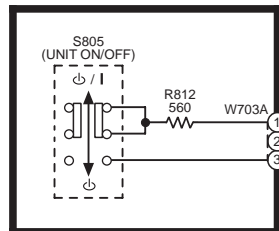
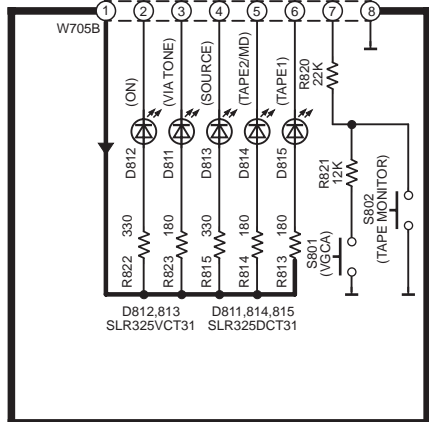
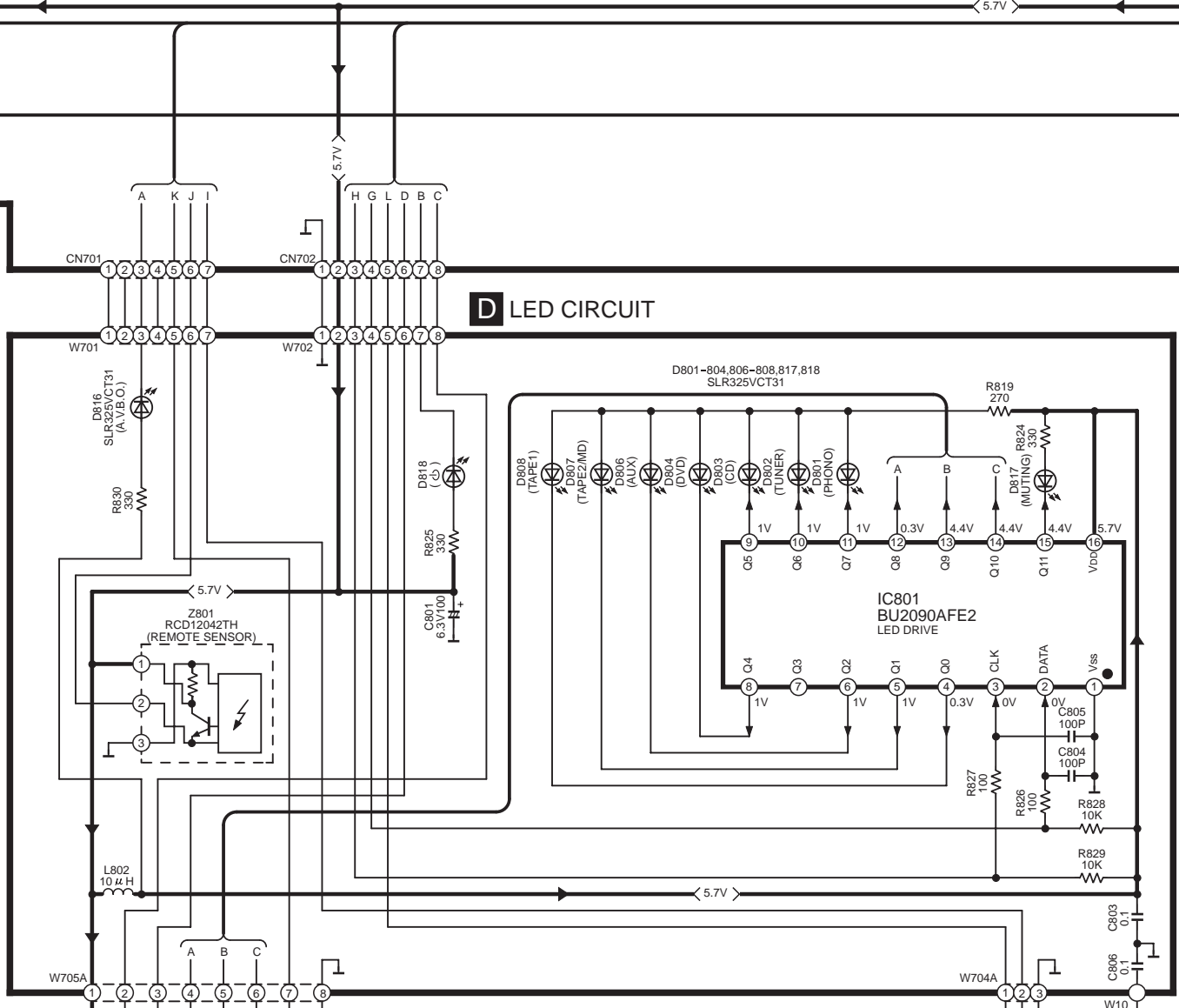

E OPERATION CIRCUIT

F POWER SWITCH CIRCUIT

G SELECTOR CIRCUIT

A MAIN CIRCUIT

→ : POSITIVE VOLTAGE LINE - - - - - : NEGATIVE VOLTAGE LINE ⇨ : PHONO SIGNAL LINE

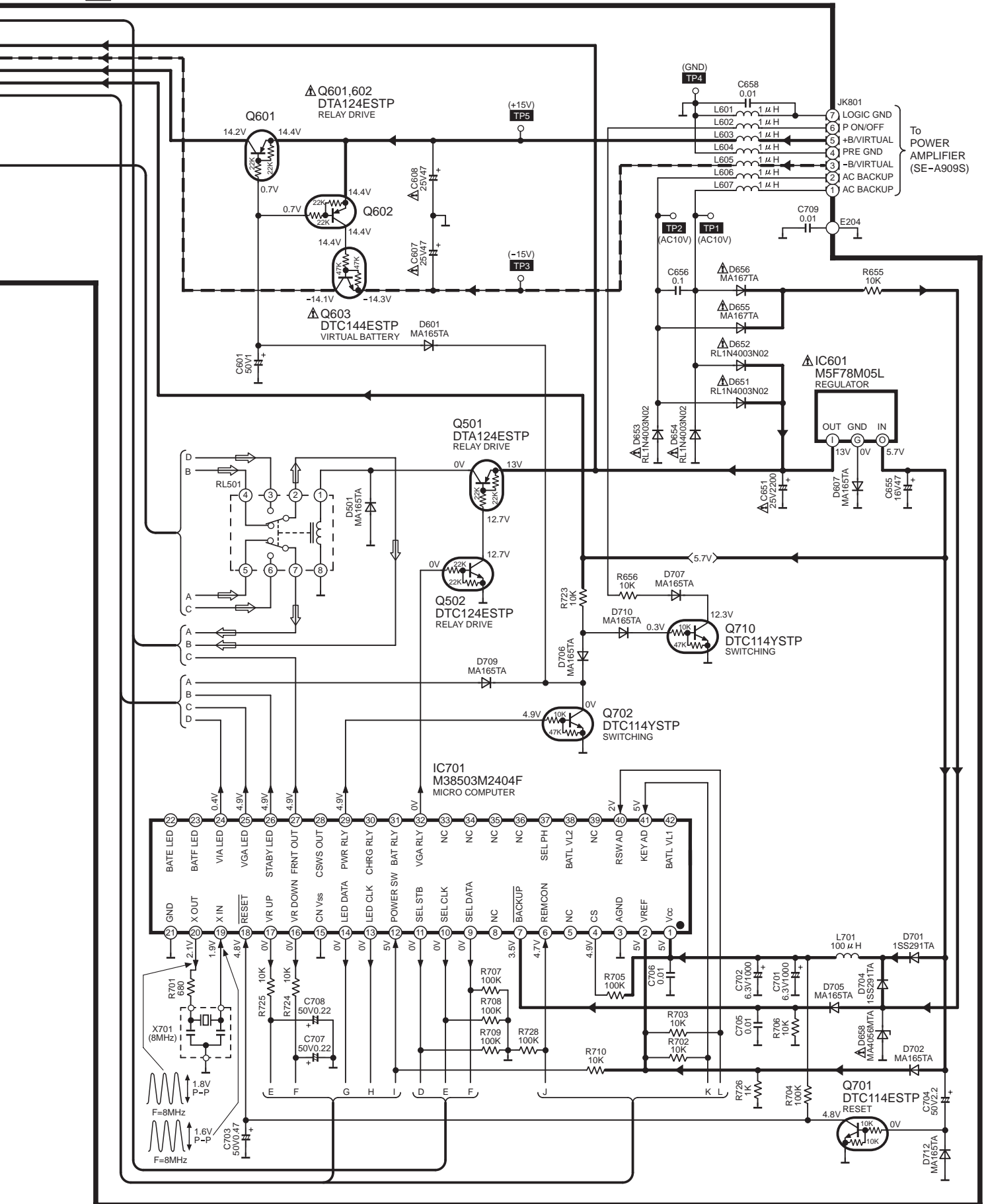

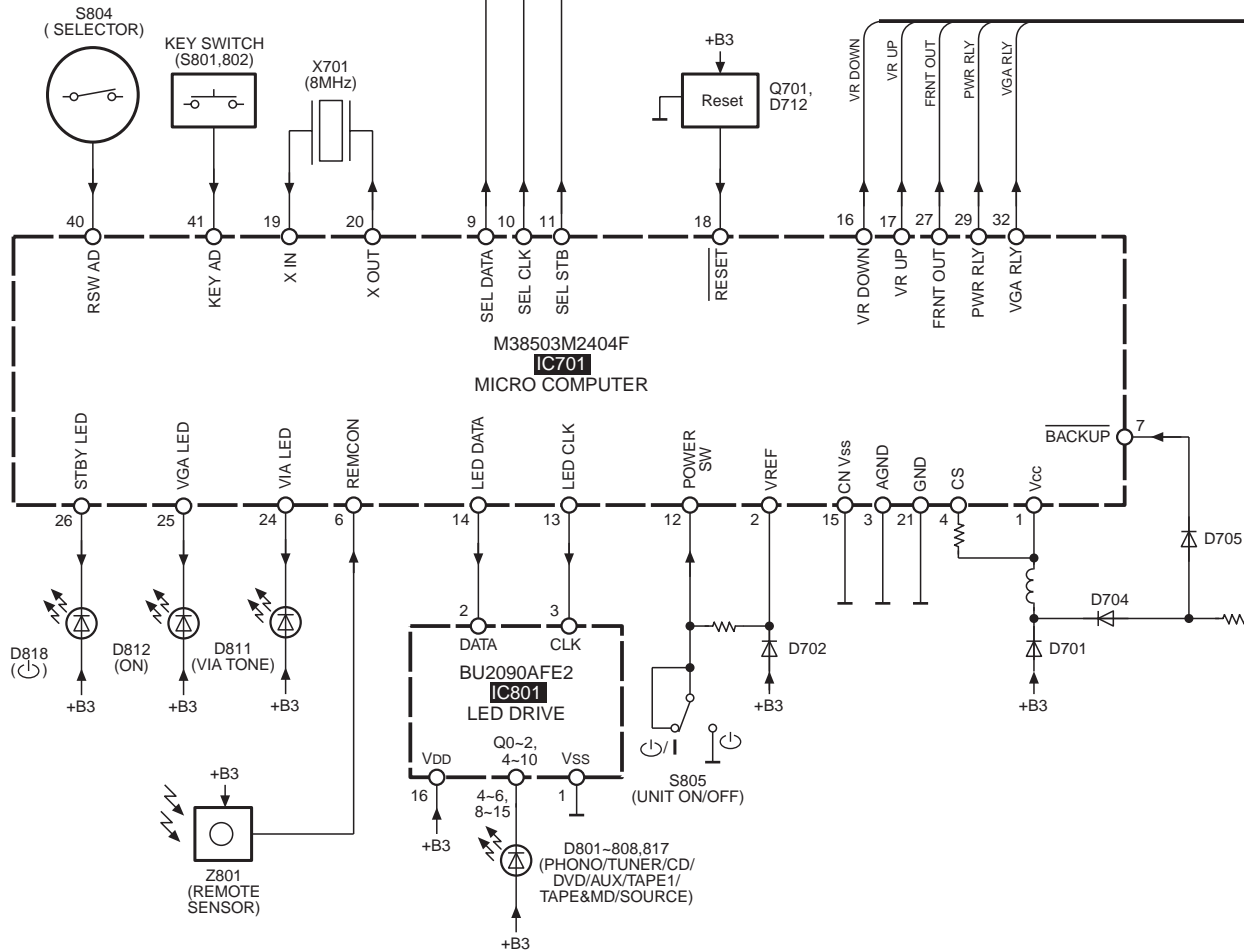
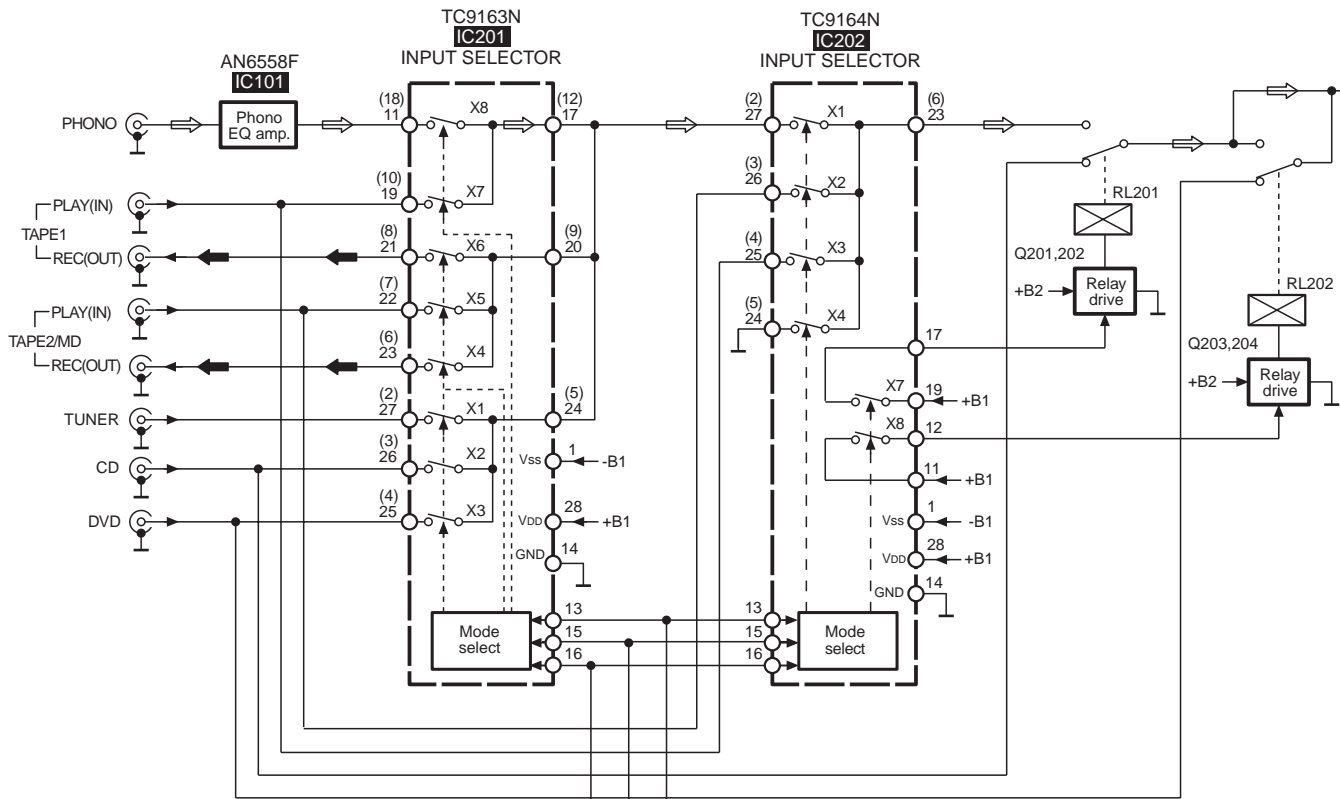

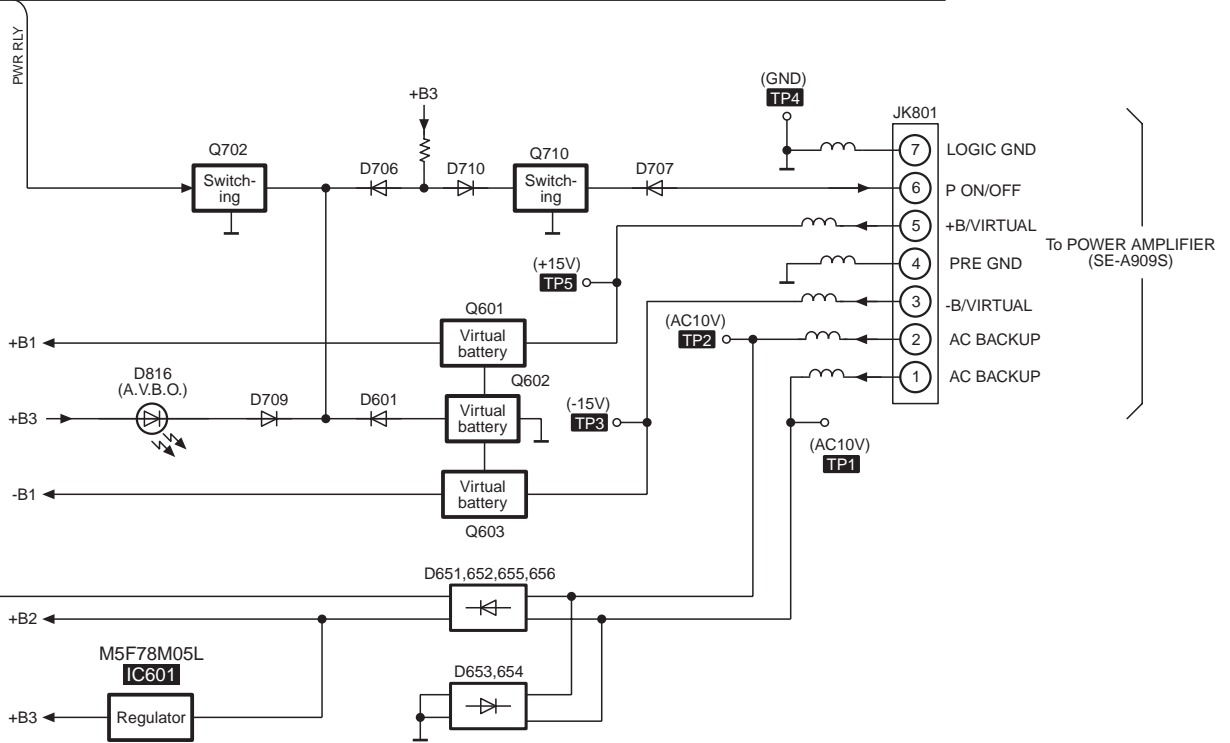
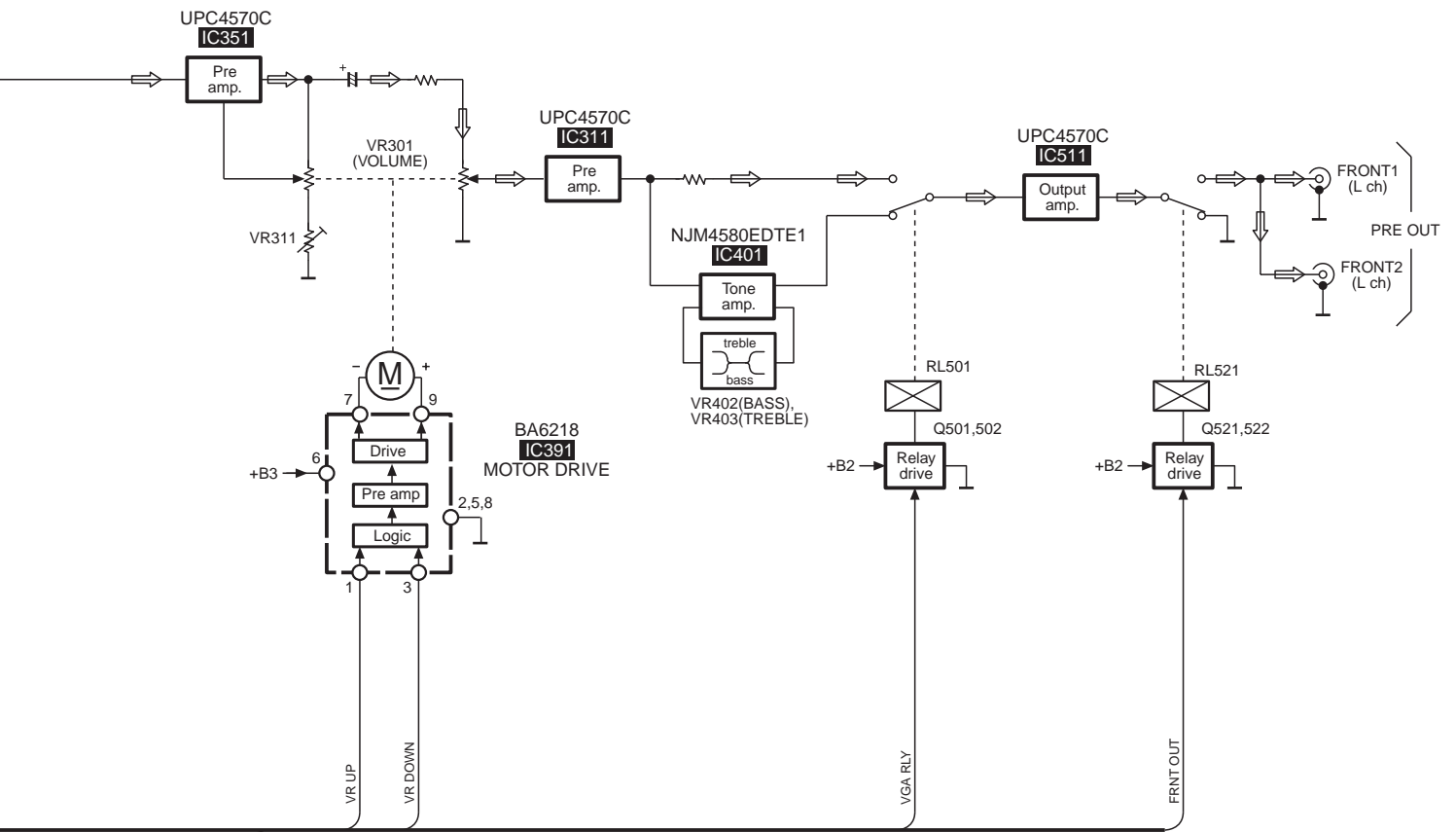

Notes

- Signal line
- ➡ : PHONO signal
- ➡ : TAPE REC signal
- () indicates pin No. Right channel.

UPC4570C
AN6558F

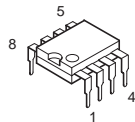

BA6218

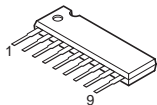

TC9163N	28PIN
TC9164N	28PIN

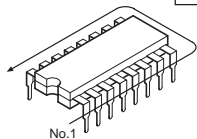

NJM4580EDTE1	8PIN
BU2090AFE2	16PIN
M38503M2404F	42PIN

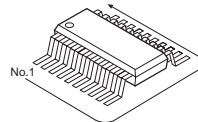

M5F78M05L

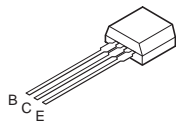
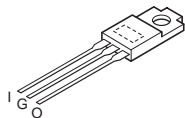

DTC114ESTP
DTC114YSTP
DTA124ESTP
DTC124ESTP
DTC144ESTP

RL1N4003N02

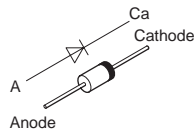

MA165TA
MA167TA

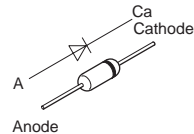

1SS291TA

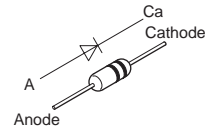

SLR325DCT31
SLR325VCT31

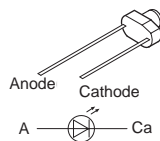

MA4056MTA

