

Service Manual

Stereo Integrated Amplifier

Original

SU-C04

[PA],[PE]

Areas

[PA] is available in for East PX.
[PE] is available in European Military.

Please use this manual together with the service manual for Model No. SU-C04 [EX, EK, XA, EL, EF, EH, EB] Order No. SD81061911C8.

CHANGES

REPLACEMENT PARTS LIST

Ref. No.		Change of Part No.		Part Name & Description	Per Set (Pcs.)	Remarks
		SU-C04 (SD81061911C8)	SU-C04 [PA], [PE]			
CABINET and CHASSIS PARTS						
1	○ ⊗	SYW521 SYW429	SYW463	Panel, Front Ass'y	1	○
10		SGP2750-1A [XA] SGP2750-2A [EX, EK, EF, EH, EB] SGP2750-3A [XL]	SGP2750-1B	Rear Panel	1	○
12	△ △ △ △	QFC1207MA [XL] SJA88 [EF, EH, EB, EX] QFC1205M [EK] SJA111 [XA]	RJA52Z	AC Cord	1	
13		SHR127 [EF, EH, EB, EX, XA] SHR129 [EK] SHR131 [XL]	SHR127	Bushing, AC Cord	1	
19	△	SJS9221 [XA]	SJS9221	AC Outlet	3	
		SGT24750 [EX] SGT24770 [EK, EF, EH, EB] SGT24790 [XA, XL]	SGT24790	Name Plate	1	
ACCESSORIES						
A1		SQF10819 [EX, EF, EH, EB] SQF10821-1 [EK, XL] SQF10823 [XA]	SQF10825	Instructions Book	1	○
A2	△	SJP5215 [XA]	Deletion	Plug Adapter, AC Power	0	
A3	△	SJP5213-1 [XA]	Deletion	Plug Adapter, AC Power	0	
A4	△	Addition	RJP120ZBS	Plug Adapter, AC Power	1	
PACKING PARTS						
P1		SGP3213 [EX, EK, XA, EH, EB] SGP3211 [EF] SGP3215 [XL]	SPG3213	Carton Box	1	
P2		SPS3227 SPS3227-1 [XL]	SPS3227	Pad, Left	1	
P3		SPS3229 SPS3229-1 [XL]	SPS3229	Pad, Right	1	

Technics

Panasonic Tokyo
Matsushita Electric Industrial Co., Ltd.
17-15,6-chome, Shinbashi, Minato-ku, Tokyo 105 Japan

Matsushita Electric Trading Co., Ltd.
P. O. Box 288, Central Osaka Japan

Printed in Japan
81070450 ⓂAM

1945

Service Manual

Stereo Integrated Amplifier

SU-C04

[EX],[EK],[XA],[XL],
[EF],[EH],[EB]

SU-C04 (K)

[EX],[EH],[XA]

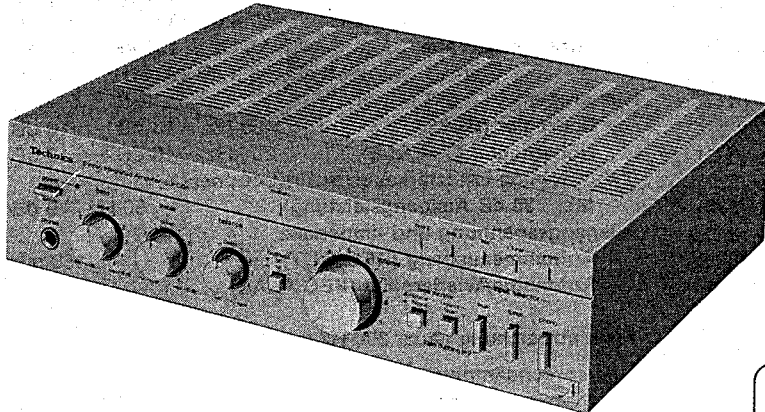

Areas

[EX] is available in Scandinavia.
 [EK] is available in United Kingdom.
 [XA] is available in Southeast Asia, Oceania, Africa, Middle
 Near East and Central South America.
 [XL] is available in Australia.
 [EF] is available in France.
 [EH] is available in Holland.
 [EB] is available in Belgium.

*The cabinet and front panel are available in black color and silver types.
 * The black type model is provided with (K) in the Service Manual.

English

Specifications

(Specifications are subject to change without notice for further improvement.)

Weights and dimensions shown are approximate.

(DIN 45 500)

■ AMPLIFIER SECTION

20 Hz~20 kHz continuous power output both channels driven	2 × 30W (8Ω)	-26 dB power PHONO	66 dB
40 Hz~16 kHz continuous power output both channels driven	2 × 30W (8Ω)	TUNER, AUX, TAPE	66 dB
1 kHz continuous power output both channels driven	2 × 30W (8Ω)	50 mW power PHONO	64 dB
Total harmonic distortion rated power at 20 Hz~20 kHz	0.007% (8Ω)	TUNER, AUX, TAPE	64 dB
rated power at 40 Hz~16 kHz	0.007% (8Ω)	Frequency response PHONO	RIAA standard curve ±0.8 dB (30 Hz~15 kHz) 5 Hz~100 kHz (-3 dB) 0 dB, -0.3 dB (20 Hz~20 kHz)
rated power at 1 kHz	0.003% (8Ω)	TUNER, AUX, TAPE	
half power at 20 Hz~20 kHz	0.007% (8Ω)	Tone controls BASS	50 Hz, +10 dB~-10 dB
half power at 1 kHz	0.003% (8Ω)	TREBLE	20 kHz, +10 dB~-10 dB
Intermodulation distortion rated power at 60 Hz: 7 kHz=4:1, SMPTE, 8Ω	0.007%	Loudness control (volume at -30 dB)	50 Hz, +9 dB
Power bandwidth both channels driven, -3 dB	5 Hz~50 kHz (8Ω, 0.02%)	Output voltage and impedance REC OUT	150 mV
Residual hum and noise	0.5 mV	REC/PLAY	30 mV/82kΩ
Damping factor	60 (8Ω)	Channel balance, AUX 250 Hz~6,300 Hz	±1.0 dB
Input sensitivity and impedance PHONO	2.5 mV/47kΩ	Channel separation, AUX 1 kHz	55 dB
TUNER, AUX	150 mV/22kΩ	Headphones output level and impedance	370 mV/330Ω
TAPE 1 REC/PLAY	150 mV/22kΩ	Load impedance	6Ω~16Ω
PHONO maximum input voltage (1 kHz, RMS) S/N	130 mV		
rated power PHONO	76 dB (IHF, A: 82 dB)	■ GENERAL	
TUNER, AUX, TAPE	90 dB (IHF, A: 98 dB)	Power consumption	300W
		Power supply	AC 50 Hz/60 Hz, 110V/120V/220V/240V
		Dimensions (W×H×D)	297 × 74 × 230 mm (11-11/16" × 2-29/32" × 9-1/16")
		Weight	4.5 kg (9.9 lb.)

Note:

Total harmonic distortion is measured by the digital spectrum analyzer (H.P. 3045 system).

Technics

Matsushita Electric Trading Co., Ltd.
 P.O. Box 288, Central Osaka Japan

TECHNISCHE DATEN (Spezifikationen Können infolge von Verbesserungen ohne Ankündigung geändert werden.)

(DIN 45 500)

■ VERSTÄRKERTEIL

Dauerton-Ausgangsleistung bei 20 Hz ~ 20 kHz beide Kanäle angesteuert	2 x 30W (8 Ω)
Dauerton-Ausgangsleistung bei 40 Hz ~ 16 kHz beide Kanäle angesteuert	2 x 30W (8 Ω)
Dauerton-Ausgangsleistung bei 1 kHz beide Kanäle angesteuert	2 x 30W (8 Ω)
Gesamtklirrfaktor	
Nennleistung bei 20 Hz ~ 20 kHz	0,007% (8 Ω)
Nennleistung bei 40 Hz ~ 16 kHz	0,007% (8 Ω)
Nennleistung bei 1 kHz	0,003% (8 Ω)
halbe Nennleistung bei 20 Hz ~ 20 kHz	0,007% (8 Ω)
halbe Nennleistung bei 1 kHz	0,003% (8 Ω)
Intermodulationsfaktor	
Nennleistung bei 60 Hz: 7 kHz = 4:1, nach SMPTE, 8 Ω	0,007%
Leistungsbandbreite	
beide Kanäle angesteuert bei -3 dB	5 Hz ~ 50 kHz (8 Ω, 0,02%)
Restbrumm und Geräusch	0,5 mV
Dämpfungsfaktor	60 (8 Ω)
Eingangsempfindlichkeit und -impedanz	
Phono	2,5 mV/47 kΩ
Tuner, Aux	150 mV/22 kΩ
Tape 1 Aufnahme/Wiedergabe (TAPE 1 REC/PLAY)	150 mV/22 kΩ
Maximale TA-Eingangsspannung (1 kHz, eff.)	130 mV
Geräuschabstand	
Nennleistung	
Phono	76 dB (nach IHF, A: 82 dB)
Tuner, Aux, Tape	90 dB (nach IHF, A: 98 dB)
-26 dB Leistung	
Phono	66 dB
Tuner, Aux, Tape	66 dB
50 mW Leistung	
Phono	64 dB
Tuner, Aux, Tape	64 dB

Frequenzgang	
Phono	RIAA-Standardkurve ±0,8 dB (30 Hz ~ 15 kHz)
Tuner, Aux, Tape	5 Hz ~ 100 kHz (-3 dB) 0 dB, -0,3 dB (20 Hz ~ 20 kHz)
Klangregler	
Baßregler (BASS)	50 Hz, +10 dB ~ -10 dB
Höhenregler (TREBLE)	20 kHz, +10 dB ~ -10 dB
Gehörliche Lautstärkekorrektur (Loudness) (bei -30 dB Ausgangsleistung)	50 Hz, +9 dB
Ausgangsspannung und -impedanz	
Aufnahmeausgang (REC OUT)	150 mV
Aufnahme/Wiedergabe (REC/PLAY)	30 mV/82 kΩ
Kanalabweichung (Aux, 250 Hz ~ 6300 Hz)	±1,0 dB
Übersprechdämpfung (Aux, 1 kHz)	55 dB
Kopfhörerpegel und -impedanz	370 mV/330 Ω
Lautsprecherimpedanz	6 Ω ~ 16 Ω

■ ALLGEMEINE DATEN

Leistungsaufnahme	300 W
Netzspannung	Wechselstrom 50 Hz/60 Hz, 110V/120V/220V/240V
Abmessungen (B×H×T)	297 x 74 x 230 mm
Gewicht	4,5 kg

Bemerkung:

Der Gesamtklirrfaktor wurde mit einem digitalen Rauschspektrometer (Anlage H.P. 3045) gemessen.

CARACTERISTIQUES (Sujet à changement sans préavis.)

(DIN 45 500)

■ SECTION AMPLIFICATEUR

Puissance de sortie continue de 20 Hz~20 kHz, les deux canaux en circuit	2 x 30W (8Ω)
Puissance de sortie continue de 40 Hz~16 kHz, les deux canaux en circuit	2 x 30W (8Ω)
Puissance de sortie continue à 1 kHz les deux canaux en circuit	2 x 30W (8Ω)
Distorsion harmonique totale	
à puissance nominale (20 Hz~20 kHz)	0,007% (8Ω)
à puissance nominale (40 Hz~16 kHz)	0,007% (8Ω)
à puissance nominale (1 kHz)	0,003% (8Ω)

à demi-puissance (20 Hz~20 kHz)	0,007% (8Ω)
à demi-puissance (1 kHz)	0,003% (8Ω)
Distorsion d'intermodulation	
à puissance nominale à 60 Hz: 7 kHz=4:1, SMPTE, 8Ω	0,007%
Réponse de fréquences	
les deux canaux en circuit, -3 dB	5 Hz~50 kHz (8Ω, 0,02%)
Bruit et ronflement résiduels	0,5 mV
Coefficient d'amortissement	60 (8Ω)
Sensibilité et impédance d'entrée	
PHONO	2,5 mV/47kΩ
SYNTONISATEUR, AUX (TUNER, AUX)	150 mV/22kΩ
BANDE 1, ENREGISTREMENT/LECTURE (TAPE 1 REC/PLAY)	150 mV/22kΩ

PHONO (tension d'entrée maximum, 1 kHz RMS)	130 mV
Signal/Bruit	
à puissance nominale	
PHONO	76 dB (IHF, A: 82 dB)
SYNTONISATEUR, AUX, BANDE	
(TUNER, AUX, TAPE)	90 dB (IHF, A: 98 dB)
puissance de -26 dB	
PHONO	66 dB
SYNTONISATEUR, AUX, BANDE	
(TUNER, AUX, TAPE)	66 dB
puissance de 50 mW	
PHONO	64 dB
SYNTONISATEUR, AUX, BANDE	
(TUNER, AUX, TAPE)	64 dB
Réponse de fréquence	
PHONO	Courbe nominale RIAA ±0,8 dB (30 Hz~15 kHz)
SYNTONISATEUR, AUX, BANDE (TUNER, AUX, TAPE)	5 Hz~100 kHz (-3 dB) 0 dB, -0,3 dB (20 Hz~20 kHz)
Réglage de la tonalité	
BASSES (BASS)	50 Hz, +10 dB~-10 dB
AIGUS (TREBLE)	20 kHz, +10 dB~-10 dB

Compensateur physiologique (volume à -30 dB)	50 Hz, +9 dB
Tension de sortie et impédance	
SORTIE ENREGISTREMENT (REC OUT)	150 mV
ENREGISTREMENT/LECTURE(REC/PLAY)	30 mV/82kΩ
Equilibrage des canaux, AUX 250 Hz~6 300 Hz	±1,0 dB
Séparation des canaux, AUX 1 kHz	55 dB
Niveau de sortie des casques et impédance	370 mV/330Ω
Impédance de charge	6Ω~16Ω

■ **DIVERS**

Consommation	300W
Alimentation	CA 50 Hz/60 Hz, 110V/120V/220V/240V
Dimensions (LxHxPr)	297 x 74 x 230 mm
Poids	4,5 kg

Remarque:
On mesure la distorsion harmonique totale au moyen d'un analyseur de spectre digital (Système H.P. 3045).

■ **CONTENTS**

	Page
LOCATION OF CONTROLS	3, 4
DISASSEMBLY INSTRUCTIONS	4, 5
VARIABLE RESISTORS	5
MEASUREMENTS AND ADJUSTMENTS (English) ...	6
MESSUNGEN UND JUSTIERUNGEN (Deutsch)	6
MESURAGES ET REGLAGES (Français)	6
BLOCK DIAGRAM	7

	Page
CIRCUIT BOARDS AND WIRING	
CONNECTION DIAGRAM	8 ~ 10
SCHEMATIC DIAGRAM	11 ~ 14
REPLACEMENT PARTS LIST (Electrical Parts)	15, 16
REPLACEMENT PARTS LIST (Cabinet and Chassis Parts) ...	16
EXPLODED VIEW	17, 18

■ **LOCATION OF CONTROLS**

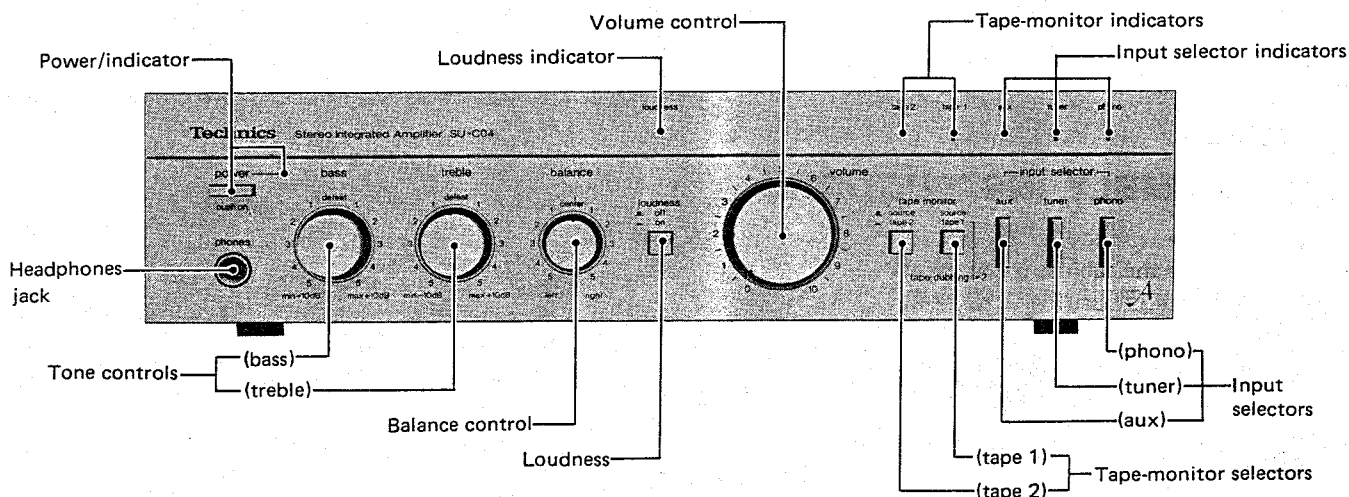

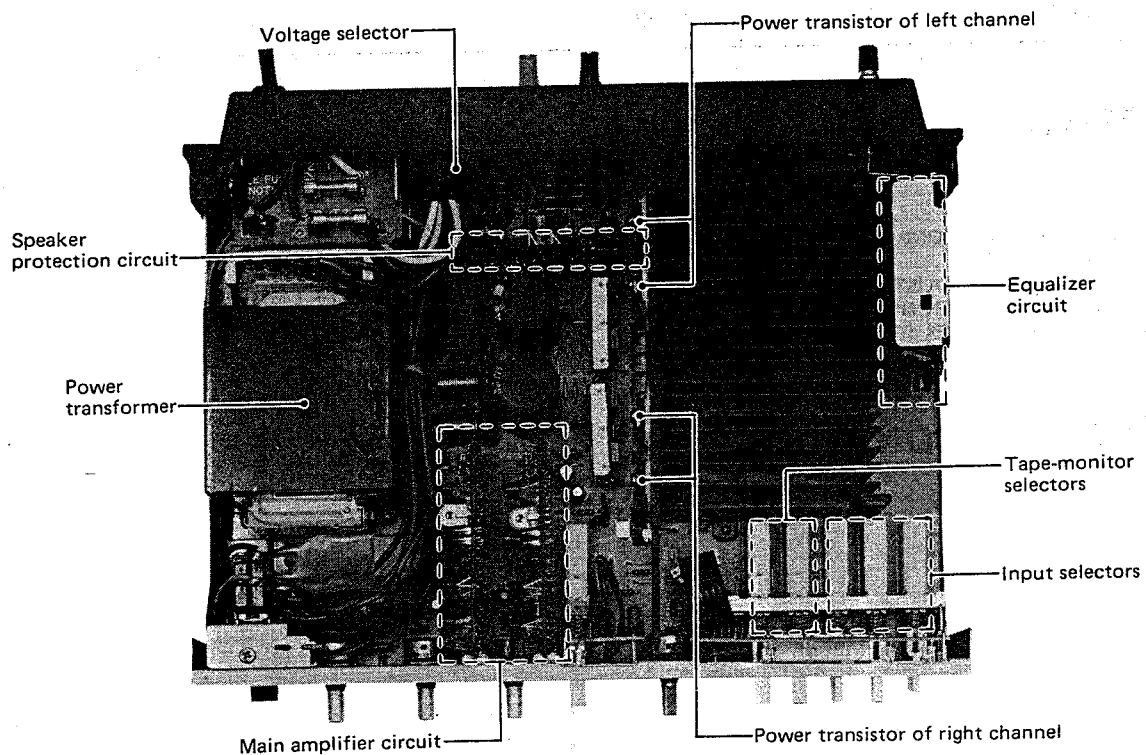
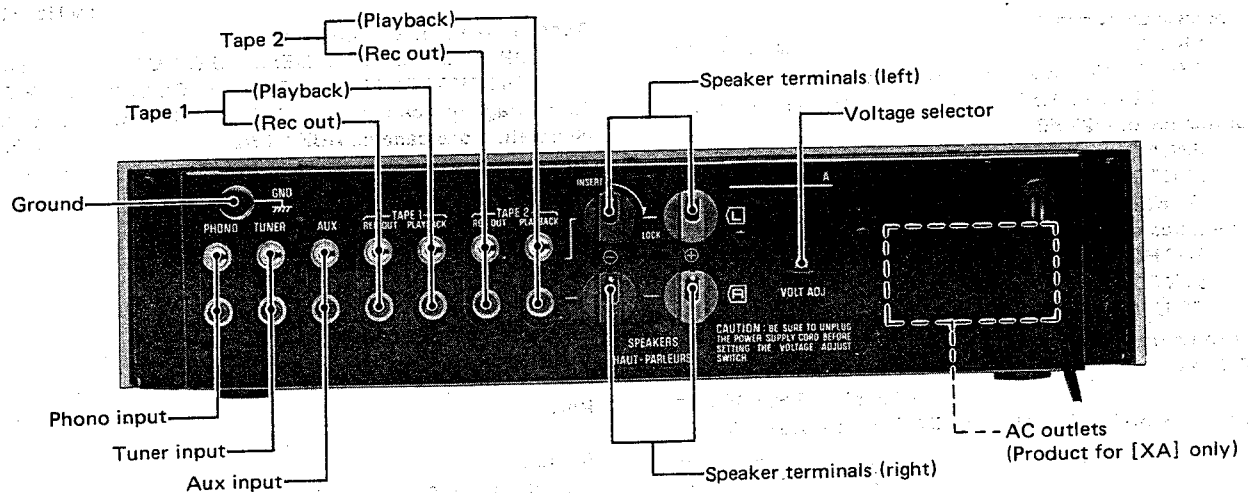

DISASSEMBLY INSTRUCTIONS

How to remove the cabinet (front panel)

1. Remove the 4 knobs (Fig. 1: ① ~ ④).
2. Remove the 4 setscrews (Fig. 1: ⑤ ~ ⑧) of the cabinet.
3. Pull the cabinet toward you and lift it up, holding it by the right and left edges, in the direction of arrow **A** in Fig. 1.

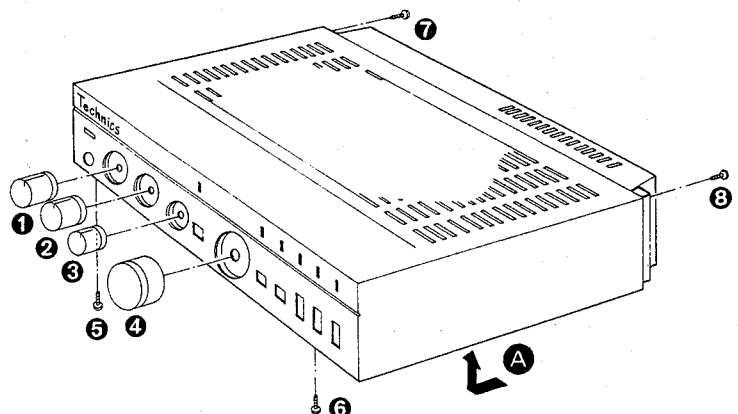

Fig. 1

SU-C04 SU-C04

How to remove the bottom board

Remove the 4 setscrews (Fig. 2: 9 ~ 12) of the bottom board.

How to remove the power transistor

1. Unsolder the power transistor as shown in Fig. 3.
2. Remove the 4 setscrews (Fig. 4: 13 ~ 16) of the heat-sink and the shielding plate setscrew (Fig. 4: 17) of the equalizer circuit printed board.
3. Pull out the speaker protection circuit printed board.
4. Lift the heat-sink along with the power transistor.
5. To install the power transistor, apply heat diffuser (silicone compound, etc.) on both sides of mica plate and attach it to the heat-sink with setscrews. And then, secure the heat-sink on the chassis and solder the power transistor.

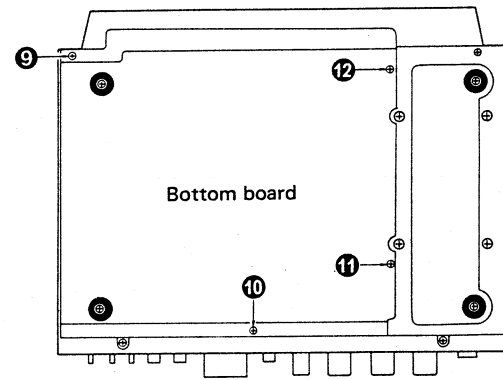

Fig. 2

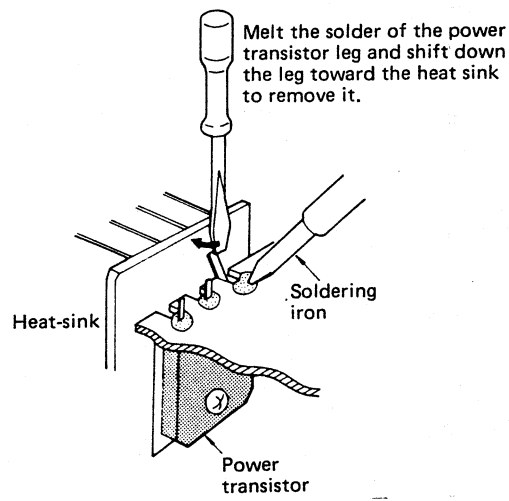

Fig. 3

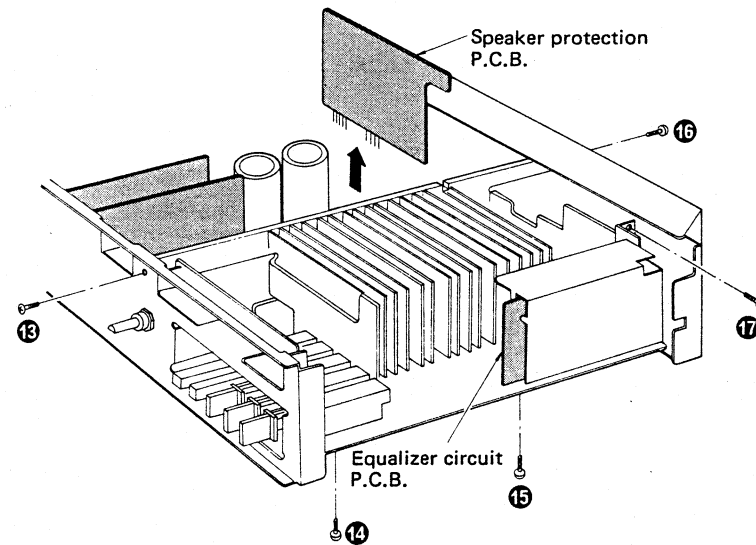
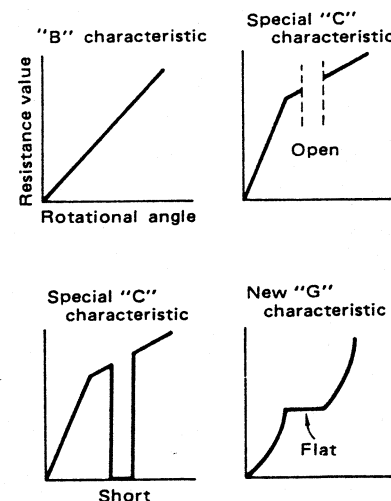

Fig. 4

VARIABLE RESISTORS

Variable resistors used in this unit

The sound volume VR and circuit adjusting semifixed volume VR are using "B" characteristic of which resistance varies in proportion to rotational angle. Treble volume VR uses special "C" characteristic of which both ends of volume are open at the middle. Bass volume VR uses special "C" characteristic of which both ends of volume are short-circuited at the middle. Balance volume VR uses "G" characteristic of which the resistance value is constant at the middle.



MEASUREMENTS AND ADJUSTMENTS English

Setting of controls and instruments to be used.

1. Sound volume 0 (minimum)
2. DC voltmeter (capable to measure 5mV)

Adjustment	DC Voltmeter Connections	Adjusting Point	Adjustment Procedure
ICQ	L channel Between TP1 and TP2 (minus probe)	VR301	* Adjust VR301 (L ch.) and VR302 (R ch.) so that the voltage is 2mV, about 1 min. after power supply ON.
	R channel Between TP3 and TP4 (minus probe)	VR302	

MESSUNGEN UND JUSTIERUNGEN Deutsch

Einstellungen und verwendete instrumente.

1. Lautstärke 0 (Minimum)
2. Gleichstrom-Voltmeter (zum Messen von 5mV geeignet)

Einstellungen	Gleichstrom-Voltmeter bindungen	Einstellungspunkte	Einstellungsvorgang
ICQ	L-Kanal Zwischen TP1 und TP2 (Minustest)	VR301	* VR301 (L-Kanal) und VR302 (R-Kanal) so justieren, daß die spannung, ca. 1 Minuten nach dem Einschalten der stromzufuhr, 2mV beträgt.
	R-Kanal Zwischen TP3 und TP4 (Minustest)	VR302	

MESURAGES ET RÉGLAGES Français

Réglages et appareils utilisés

1. Volume sonore 0 (minimum)
2. Voltmètre à C.C. (capable de mesurer 5mV)

Réglages	Connexions du voltmètre C.C.	Point de réglage	Procédé de réglage
ICQ	Canal de gauche Entre TP1 et TP2 (sonde au moins)	VR301	* Régler VR301 (canal de gauche) et VR302 (canal de droite) de façon à ce que la tension soit de 2mV, environ 1 minute après la mise en marche de la tension d'alimentation.
	Canal de droite Entre TP3 et TP4 (sonde au moins)	VR302	

Adjustment points

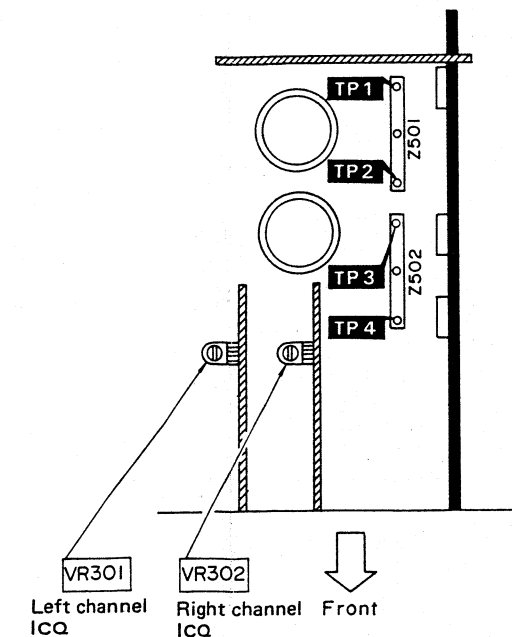

MEASUREMENTS AND ADJUSTMENTS — English

● **Setting of controls and instruments to be used.**
 1. Sound volume 0 (minimum)
 2. DC voltmeter (capable to measure 5mV)

Adjustment	DC Voltmeter Connections	Adjusting Point	Adjustment Procedure
ICQ	L channel Between TP1 and TP2 (minus probe)	VR301	* Adjust VR301 (L ch.) and VR302 (R ch.) so that the voltage is 2mV, about 1 min. after power supply ON.
	R channel Between TP3 and TP4 (minus probe)	VR302	

MESSUNGEN UND JUSTIERUNGEN — Deutsch

● **Einstellungen und verwendete instrumente.**
 1. Lautstärke 0 (Minimum)
 2. Gleichstrom-Voltmeter (zum Messen von 5mV geeignet)

Einstellungen	Gleichstrom-Voltmeter bindungen	Einstellungspunkte	Einstellungsvorgang
ICQ	L-Kanal Zwischen TP1 und TP2 (Minustest)	VR301	* VR301 (L-Kanal) und VR302 (R-Kanal) so justieren, daß die spannung, ca. 1 Minuten nach dem Einschalten der stromzufuhr, 2mV beträgt.
	R-Kanal Zwischen TP3 und TP4 (Minustest)	VR302	

MESURAGES ET RÉGLAGES — Français

● **Réglages et appareils utilisés**
 1. Volume sonore 0 (minimum)
 2. Voltmètre à C.C. (capable de mesurer 5mV)

Réglages	Connexions du voltmètre C.C.	Point de réglage	Procédé de réglage
ICQ	Canal de gauche Entre TP1 et TP2 (sonde au moins)	VR301	* Régler VR301 (canal de gauche) et VR302 (canal de droite) de façon à ce que la tension soit de 2mV, environ 1 minute après la mise en marche de la tension d'alimentation.
	Canal de droite Entre TP3 et TP4 (sonde au moins)	VR302	

● Adjustment points

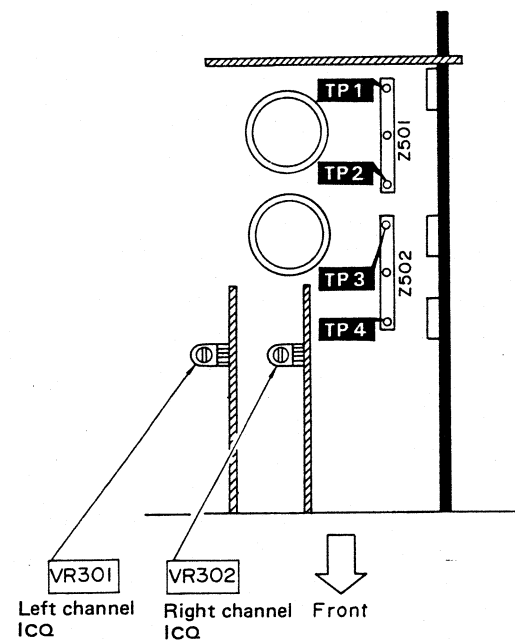

BLOCK DIAGRAM

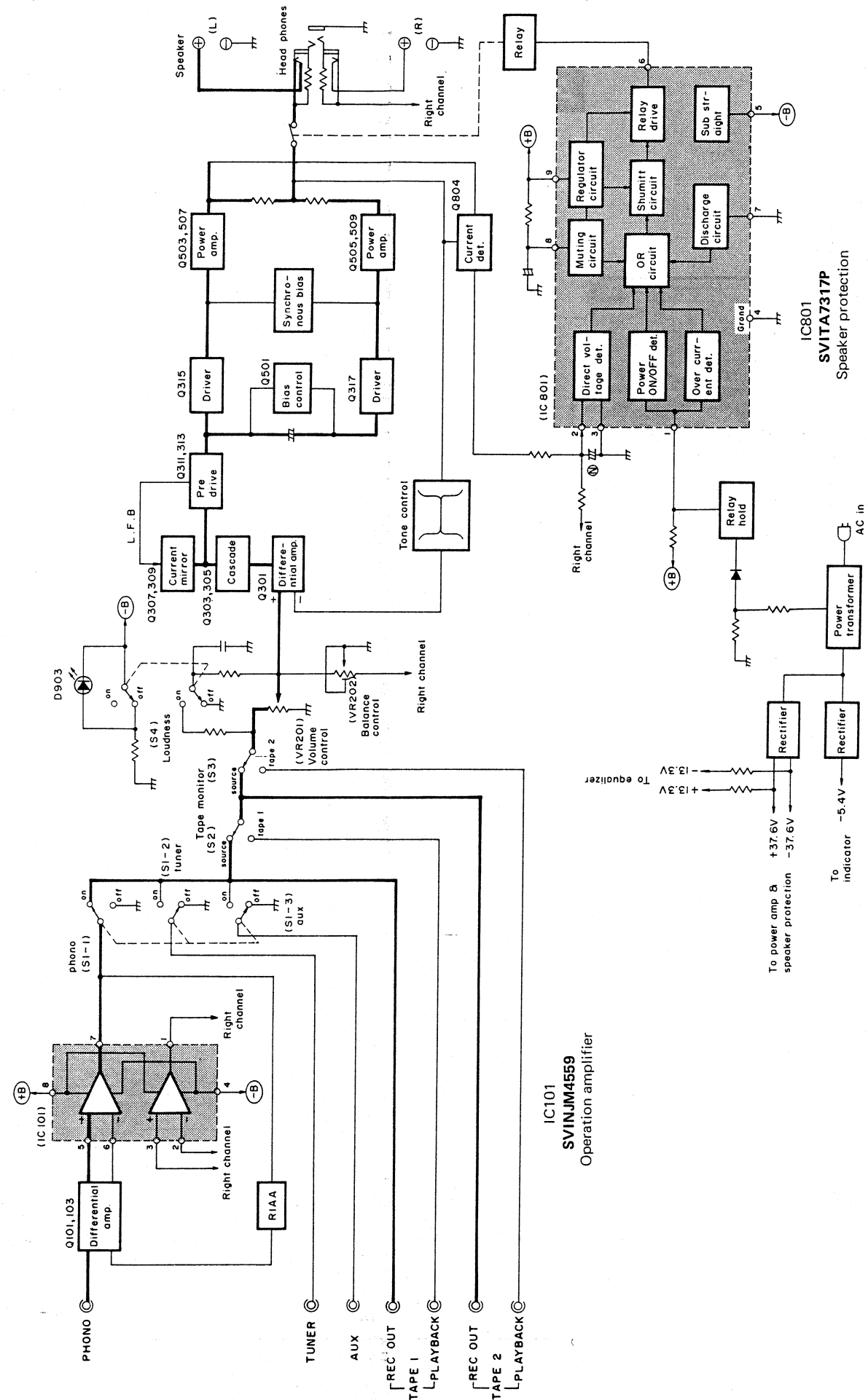

CIRCUIT BOARDS AND WIRING CONNECTION DIAGRAM

Ground (Earth) lines

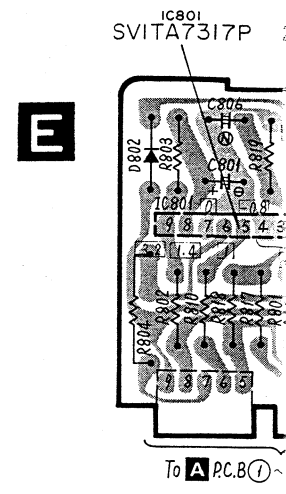
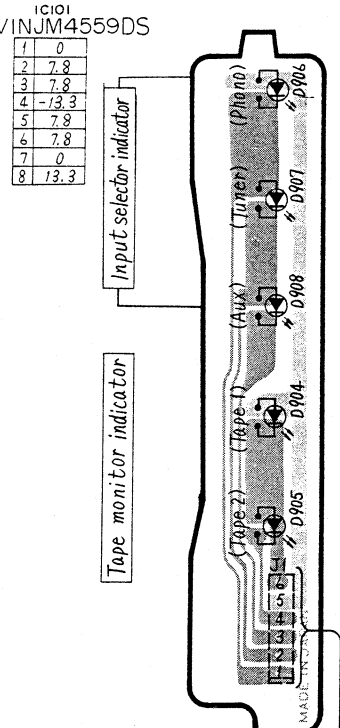
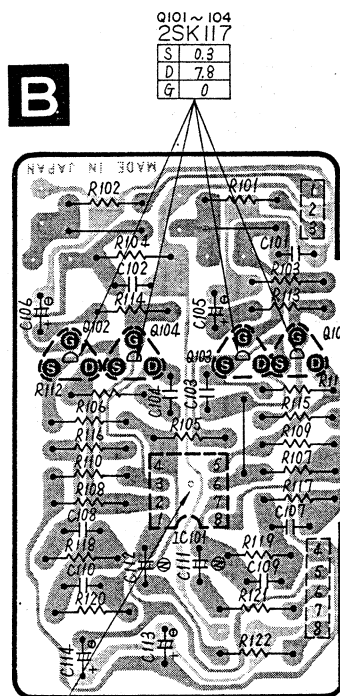
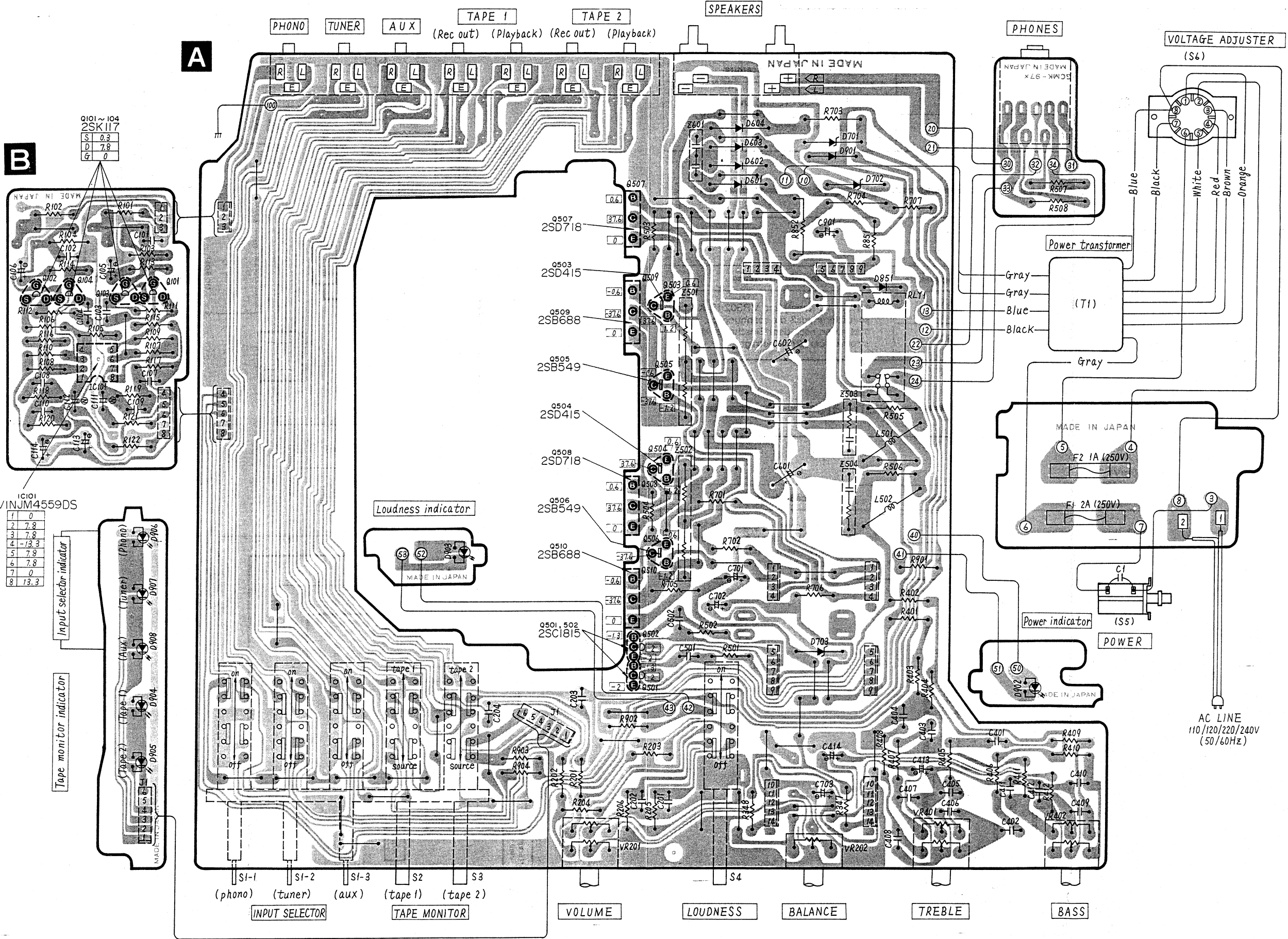

A
B
C
D
E
F

PHONO
Lch
Rch

TUNER (Lch)
AUX
REC OUT TAPE 1
PLAYBACK
REC OUT TAPE 2
PLAYBACK
TUNER (Rch)
AUX
REC OUT TAPE 1
PLAYBACK
REC OUT TAPE 2
PLAYBACK

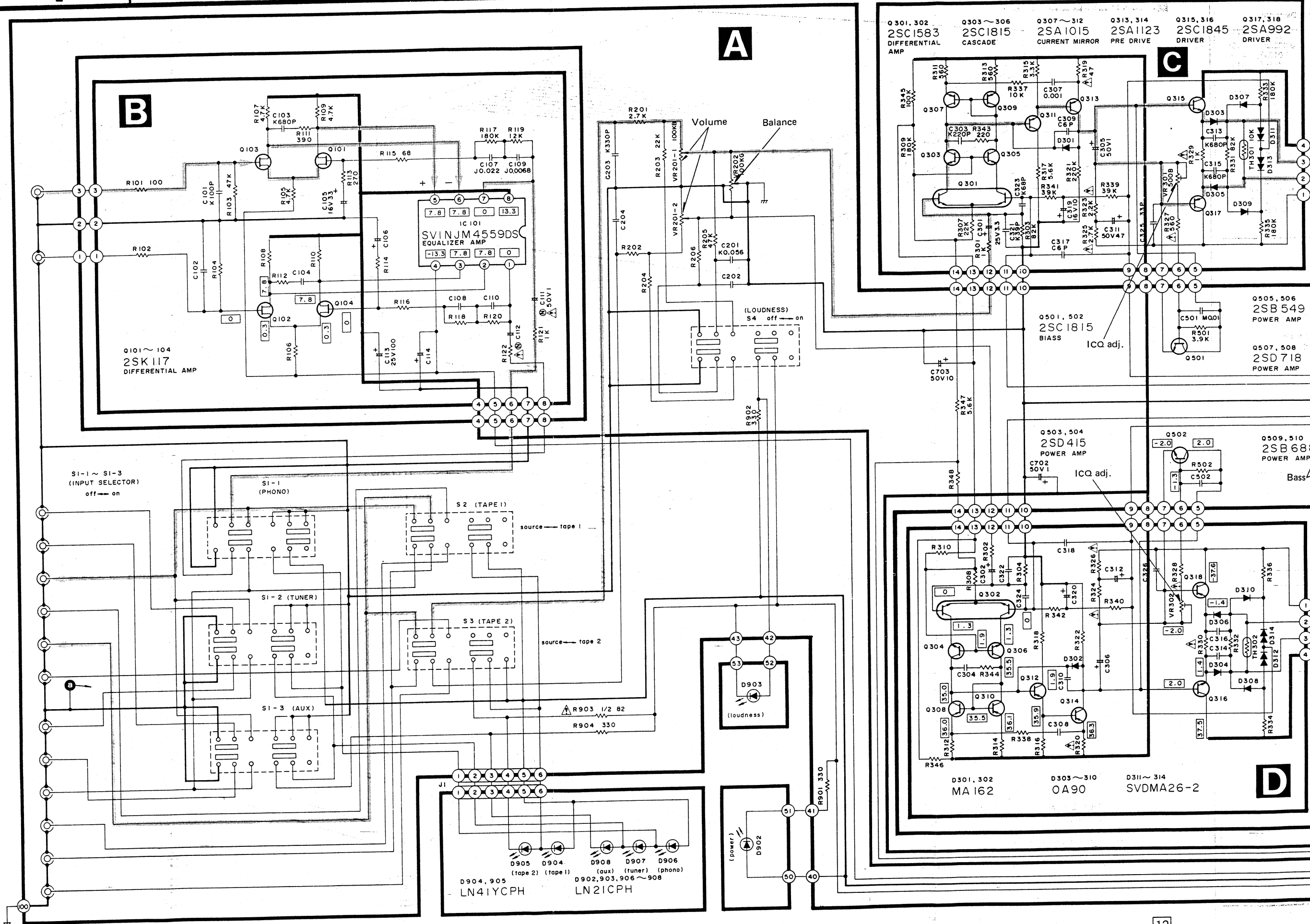

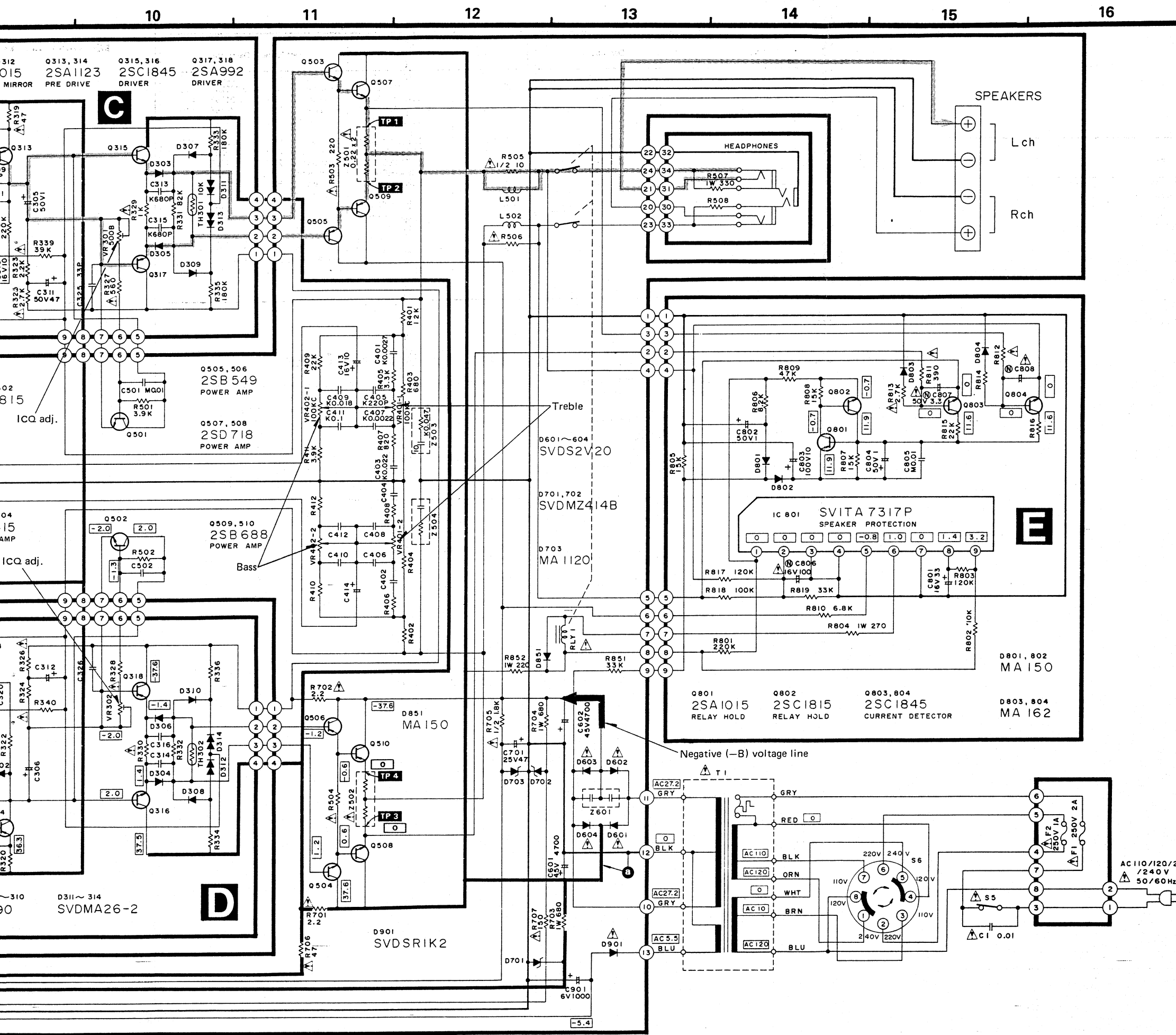

SCHEMATIC DIAGRAM

(This schematic diagram may be modified at any time with the development of new technology.)

Notes:

- S1-1~S1-3:** Input selector switch in "phono" position.
S1-1 — phono, S1-2 — tuner, S1-3 — aux
- S2:** Tape 1 monitor switch in "source" position.
source ↔ tape 1/tape dubbing 1 ▶ 2
- S3:** Tape 2 monitor switch in "source" position.
source ↔ tape 2
- S4:** Loudness switch in "off" position.
- S5:** Power switch in "on" position.
- S6:** Voltage selector switch in "120V" position.
120V ↔ 110V ↔ 220V ↔ 240V
- Indicated voltage values are the standard values for the DC electronic circuit tester (high impedance) with the chassis taken as standard. Therefore, there may exist some errors in the voltage values, depending on the internal impedance of the DC circuit tester.
- Phono signal lines of left channel.
Positive (+B) voltage lines.
- Important safety notice:** Components identified by Δ mark have special characteristics important for safety. When replacing any of these components, use only manufacturer's specified parts.

Power source circuit for [XA] area only

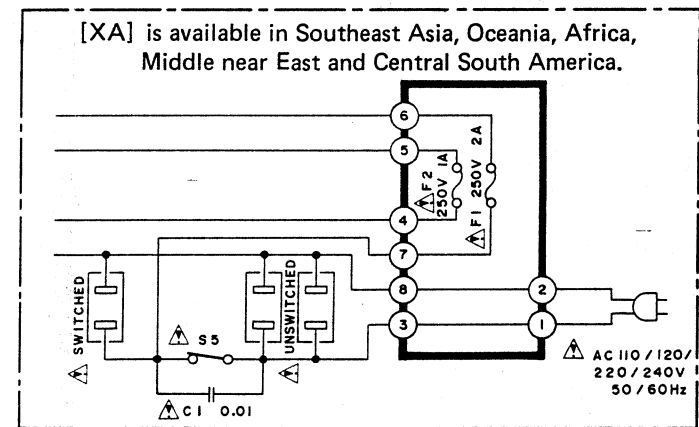

Power source circuit for [XL] area only

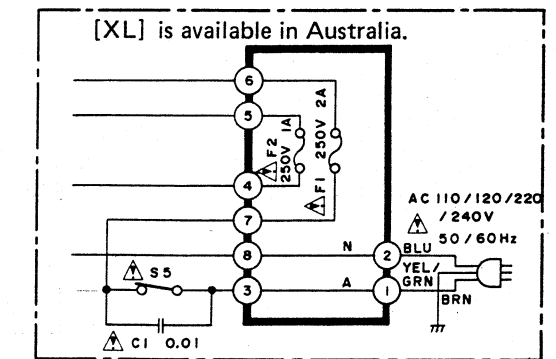

REPLACEMENT PARTS LIST Electric Parts

Notes: 1. Part numbers are indicated on most mechanical parts. Please use this part number for parts orders.
 2. Important safety notice:
 Components identified by Δ mark have special characteristics important for safety.
 When replacing any of these components, use only manufacturer's specified parts.

Ref. No.	Part No.	Part Name & Description
INTEGRATED CIRCUITS		
IC101 IC801	SVINJM459DD SVITA7317P	IC, Equalizer Amplifier IC, Speakers Protection
TRANSISTORS		
Q101 ~ 104	2SK117-GR	Transistor, Equalizer Differential Amplifier [FET]
Q301, 302 Q303 ~ 306 802	2SC1583-G 2SC1815-Y	Transistor, Differential Amplifier Transistor, Cascade and Relay Hold
Q307 ~ 312 801	2SA1015-Y	Transistor, Current Mirror and Relay Hold
Q313, 314 Q315, 316 Q317, 318	2SA1123-R 2SC1845	Transistor, Pre Drive Transistor, Driver } Use pair ranks
Q501, 502 Q503, 504 Q505, 506 Q507, 508 Q509, 510 Q803, 804	2SA992 2SC1815-Y 2SD415-Q 2SB549-Q 2SD718-O 2SB688-O 2SC1845	Transistor, Driver } Transistor, Constant Current Transistor, Power Amplifier } Use pair ranks Transistor, Power Amplifier } Transistor, Power Amplifier } R or O Transistor, Current Detector
DIODES		
D301, 302 803, 804	MA162A	Diode, Detector
D303 ~ 310 D311 ~ 314 D601 ~ 604	20A90 MA27A-2 SVDS2V20	Diode, Synchronous Bias Diode, Current Limiter Diode, Rectifier
D701, 702 D703	SVDMZ414 RVDRD12FB	Diode, 14V Zener Diode, 12V Zener
D801, 802 D851 D901	MA162A MA162A	Diode, Bias Diode, Detector
D902, 903 906 ~ 908 D904, 905	SVDSR1K2 LN21CPH LN41YCPH	Diode, Rectifier Light Emitting Diode, Power, Loudness and Input Indicator Light Emitting Diode, Tape 1, 2 Indicator
COILS		
L501, 502	SLQY15G-30	Coil, Choke
TRANSFORMER		
T1	SLT5M163-W	Transformer, Power Source
VARIABLE RESISTORS		
VR201 VR202	EWJGGA066B15 EWHHMA531G15	Volume Control, 100k Ω (B) Balance Control, 100k Ω (G)
VR301, 302 VR401 VR402	EVNMOA00B52 EWJFC0066C15 EWJFCY066530	DC Balance Adjustment, 500k Ω (B) Treble Control, 100k Ω (C) Bass Control, 100k Ω (C)
COMPONENT COMBINATIONS		
Z501, 502 Z503, 504 Z601	ERF3GBKR22N ECQJ0517 SXRFS203ZSM	Component Combination, 0.22 Ω x 2 Component Combination, 10 Ω x 0.047 μ F Component Combination, 0.01 μ F x 2
SWITCHES		
S1 ~ 3	SSH535	Switch, Input Selector and Tape Monitor
S4 S5 S6	SSH1007 ESB90619S ESE37200	Switch, Loudness Switch, Power Switch, Voltage Adjuster
RELAY		
RLY1	SSY91	Relay, Speaker Protection
THERMISTORS		
TH301, 302	ERTD2FHL103S	Thermistor, Thermal Compensation, 10k Ω
FUSES		
F1 F2	XBA2C20TRO XBA2C10TRO	Fuse, T 2.0A (250V) Fuse, T 1.0A (250V)
RESISTORS		
R101, 102 R103, 104 R105, 106 R107, 108 R109, 110	ERD25FJ101 ERD25TJ473 ERD25FJ472 ERD25FJ472 ERD25FJ472	Carbon, 1/4W, 100 Ω , \pm 5% Carbon, 1/4W, 47k Ω , \pm 5% Carbon, 1/4W, 4.7k Ω , \pm 5% Carbon, 1/4W, 4.7k Ω , \pm 5% Carbon, 1/4W, 4.7k Ω , \pm 5%

Ref. No.	Part No.	Part Name & Description
R111, 112 R113, 114 R115, 116 R117, 118 R119, 120	ERD25FJ391 ERD25FJ271 ERD25FJ680 ERD25TJ184 ERD25TJ123	Carbon, 1/4W, 390 Ω , \pm 5% Carbon, 1/4W, 270 Ω , \pm 5% Carbon, 1/4W, 68 Ω , \pm 5% Carbon, 1/4W, 180k Ω , \pm 5% Carbon, 1/4W, 12k Ω , \pm 5%
R121, 122 R201, 202 R203, 204 R205, 206 R301, 302 R303, 304 R307, 308 R309, 310 R311, 312 R313, 314	ERD25FJ102 ERD25FJ272 ERD25TJ223 ERD25TJ473 ERD25FJ102 ERD25TJ823 ERD25TJ223 ERD25TJ184 ERD25FJ561 ERD25FJ561	Carbon, 1/4W, 1k Ω , \pm 5% Carbon, 1/4W, 2.7k Ω , \pm 5% Carbon, 1/4W, 22k Ω , \pm 5% Carbon, 1/4W, 47k Ω , \pm 5% Carbon, 1/4W, 1k Ω , \pm 5% Carbon, 1/4W, 82k Ω , \pm 5% Carbon, 1/4W, 22k Ω , \pm 5% Carbon, 1/4W, 180k Ω , \pm 5% Carbon, 1/4W, 560 Ω , \pm 5% Carbon, 1/4W, 560 Ω , \pm 5%
R315, 316 R317, 318 R319, 320 R321, 322 R323, 324 R325, 326 R327, 328 R329, 330 R331, 332 R333, 334	ERD25FJ332 ERD25FJ562 ERD25TJ470 ERD25TJ224 ERD25FJ222 ERD25FJ272 ERD25FJ561 ERD25FJ102 ERD25TJ823 ERD25TJ184	Carbon, 1/4W, 3.3k Ω , \pm 5% Carbon, 1/4W, 5.6k Ω , \pm 5% Carbon, 1/4W, 47 Ω , \pm 5% Carbon, 1/4W, 220k Ω , \pm 5% Carbon, 1/4W, 2.2k Ω , \pm 5% Carbon, 1/4W, 2.7k Ω , \pm 5% Carbon, 1/4W, 560 Ω , \pm 5% Carbon, 1/4W, 1k Ω , \pm 5% Carbon, 1/4W, 82k Ω , \pm 5% Carbon, 1/4W, 180k Ω , \pm 5%
R335, 336 R337, 338 R339, 340 R341, 342 R343, 344 R345, 346 R347, 348 R401, 402 R403, 404 R405, 406	ERD25TJ184 ERD25FJ103 ERD25TJ393 ERD25TJ393 ERD25FJ221 ERD25TJ104 ERD25FJ562 ERD25TJ123 ERD25FJ681 ERD25FJ681 ERD25FJ332	Carbon, 1/4W, 180k Ω , \pm 5% Carbon, 1/4W, 10k Ω , \pm 5% Carbon, 1/4W, 39k Ω , \pm 5% Carbon, 1/4W, 39k Ω , \pm 5% Carbon, 1/4W, 220 Ω , \pm 5% Carbon, 1/4W, 100k Ω , \pm 5% Carbon, 1/4W, 5.6k Ω , \pm 5% Carbon, 1/4W, 12k Ω , \pm 5% Carbon, 1/4W, 680 Ω , \pm 5% Carbon, 1/4W, 3.3k Ω , \pm 5%
R407, 408 R409, 410 R411, 412 R501, 502 R503, 504 R505, 506 R507, 508 R701, 702 R703, 704 R705	ERD25FJ821 ERD25TJ223 ERD25FJ392 ERD25FJ392 ERD25FJ221 ERD50FJ100 ERG1ANJ331 ERD25FJ2R2 ERG1ANJ681 ERD50FJ182	Carbon, 1/4W, 820 Ω , \pm 5% Carbon, 1/4W, 22k Ω , \pm 5% Carbon, 1/4W, 3.9k Ω , \pm 5% Carbon, 1/4W, 3.9k Ω , \pm 5% Carbon, 1/4W, 220 Ω , \pm 5% Carbon, 1/2W, 10 Ω , \pm 5% Metal Oxide, 1W, 330 Ω , \pm 5% Carbon, 1/4W, 2.2 Ω , \pm 5% Metal Oxide, 1W, 680 Ω , \pm 5% Carbon, 1/2W, 1.8k Ω , \pm 5%
R706 R707 R801 R802 R803 R804 R805 R806 R807, 808 R809	ERD25FJ470 ERD25FJ151 ERD25TJ224 ERD25FJ103 ERD25TJ124 ERG1ANJ271 ERD25TJ153 ERD25FJ822 ERD25TJ153 ERD25TJ473	Carbon, 1/4W, 47 Ω , \pm 5% Carbon, 1/4W, 150 Ω , \pm 5% Carbon, 1/4W, 220k Ω , \pm 5% Carbon, 1/4W, 10k Ω , \pm 5% Carbon, 1/4W, 120k Ω , \pm 5% Metal Oxide, 1W, 270 Ω , \pm 5% Carbon, 1/4W, 15k Ω , \pm 5% Carbon, 1/4W, 8.2k Ω , \pm 5% Carbon, 1/4W, 15k Ω , \pm 5% Carbon, 1/4W, 47k Ω , \pm 5%
R810 R811, 812 R813, 814 R815, 816 R817 R818 R819 R851 R852 R901, 902 R903 R904	ERD25FJ682 ERD25FJ391 ERD25FJ272 ERD25TJ104 ERD25TJ124 ERD25TJ104 ERD25TJ333 ERD25TJ333 ERG1ANJ221 ERD25FJ331 ERD50FJ820 ERD25FJ331	Carbon, 1/4W, 6.8k Ω , \pm 5% Carbon, 1/4W, 390 Ω , \pm 5% Carbon, 1/4W, 2.7k Ω , \pm 5% Carbon, 1/4W, 100k Ω , \pm 5% Carbon, 1/4W, 120k Ω , \pm 5% Carbon, 1/4W, 100k Ω , \pm 5% Carbon, 1/4W, 33k Ω , \pm 5% Carbon, 1/4W, 33k Ω , \pm 5% Metal Oxide, 1W, 220 Ω , \pm 5% Carbon, 1/4W, 330 Ω , \pm 5% Carbon, 1/2W, 82 Ω , \pm 5% Carbon, 1/4W, 330 Ω , \pm 5%
CAPACITORS		
C1, 2 C101, 102 C103, 104 C105, 106 C107, 108 C109, 110	ECKDKC103PE ECCD1H101K ECKD1H681KB ECEA1CG330S ECQM1H223J ECQM1H682J	Ceramic, 400VAC, 0.01 μ F, \pm 10% Ceramic, 50V, 100pF, \pm 10% Ceramic, 50V, 680pF, \pm 10% Electrolytic, 16V, 33 μ F Polyester, 50V, 0.022 μ F, \pm 5% Polyester, 50V, 0.0068 μ F, \pm 5%

Ref. No.	Part No.	Part Name & Description
C111, 112 C113, 114 C201, 202 C203, 204	ECEA1HGNO10S ECEA1EG101S ECQM1H563KZ ECKD1H331KB	Non-Polar Electrolytic, 50V, 1 μ F Electrolytic, 25V, 100 μ F Polyester, 50V, 0.056 μ F, \pm 10% Ceramic, 50V, 330pF, \pm 10%
C301, 302 C303, 304 C305, 306 C307, 308 C309, 310 C311, 312 C313, 314 C315, 316 C317, 318 C319, 320	ECEA1EKL3R3 ECKD1H221KB ECEA1HKL010 ECKD1H102MD ECCD1H060C ECEA1HG470S ECKD1H681KB ECKD1H681KB ECCD1H060C ECEA1CKL100	Electrolytic, 25V, 3.3 μ F Ceramic, 50V, 220pF, \pm 10% Electrolytic, 50V, 1 μ F Ceramic, 50V, 0.001 μ F, \pm 20% Ceramic, 50V, 6pF, \pm 0.25pF Electrolytic, 50V, 47 μ F Ceramic, 50V, 680pF, \pm 10% Ceramic, 50V, 680pF, \pm 10% Ceramic, 50V, 6pF, \pm 0.25pF Electrolytic, 16V, 10 μ F
C321, 322 C323, 324 C325, 326 C401, 402 C403, 404	ECCD1H390K ECCD1H680K ECCD1H330K ECQM1H272KZ ECQM1H223KZ	Ceramic, 50V, 39pF, \pm 10% Ceramic, 50V, 68pF, \pm 10% Ceramic, 50V, 33pF, \pm 10% Polyester, 50V, 0.0027 μ F, \pm 10% Polyester, 50V, 0.022 μ F, \pm 10%

Ref. No.	Part No.	Part Name & Description
C405, 406 C407, 408 C409, 410 C411, 412 C413, 414	ECCD1H221K ECQM1H222KZ ECQM1H183KZ ECQM1H104KZ ECEA1CKL100	Ceramic, 50V, 220pF, \pm 10% Polyester, 50V, 0.0022 μ F, \pm 10% Polyester, 50V, 0.018 μ F, \pm 10% Polyester, 50V, 0.1 μ F, \pm 10% Electrolytic, 16V, 10 μ F
C501, 502 C601, 602 C701 C702 C703 C801 C802 C803 C804 C805 C806 C807, 808 C901	ECKD1H103MD ECES45R472Z ECEA1EG470S ECEA1HG101S ECEA1HG100S ECEA1CG330S ECEA1HKL010 ECEA2AG100S ECEA1HKL010 ECKD1H103MD ECEA1CGN101S ECEA1HG3R3S ECEA0JG102S	Ceramic, 50V, 0.01 μ F, \pm 20% Electrolytic, 45V, 4700 μ F Electrolytic, 25V, 47 μ F Electrolytic, 50V, 1 μ F Electrolytic, 50V, 10 μ F Electrolytic, 16V, 33 μ F Electrolytic, 50V, 1 μ F Electrolytic, 100V, 10 μ F Electrolytic, 50V, 1 μ F Ceramic, 50V, 0.01 μ F, \pm 20% Non-Polar Electrolytic, 16V, 100 μ F Non-Polar Electrolytic, 50V, 3.3 μ F Electrolytic, 6.3V, 1000 μ F

REPLACEMENT PARTS LIST Cabinet and Chassis Parts

Notes: 1. Part numbers are indicated on most mechanical parts. Please use this part number for parts orders.
 2. Important safety notice:
 Components identified by Δ mark have special characteristics important for safety.
 When replacing any of these components, use only manufacturer's specified parts.
 3. \square -marked parts are used for black only, while \circ -marked parts are for silver type only.
 4. Parts other than \square and \circ -marked are used for both black and silver types.
 5. Bracketed indications in Ref. No. columns specify the area. Parts without these indications can be used for all areas.

Black type model No.: SU-C04 (K)

Ref. No.	Part No.	Part Name & Description
CABINET and CHASSIS PARTS		
1 1	SYW521 SYW479	Panel, Front Ass'y (Silver) Panel, Front Ass'y (Black)
2 3 4 5 6 7 8 9	SBN1053 SBN1055 SBN1057 SBC315-1 SBC399 XCJ56P21E-A SFJ3049N SJF4431	Knob, Volume Control Knob, Balance Knob, Bass/Treble Control Button, Input Selector Button, Loudness and Tape Monitor Jack, Head Phone Terminal Board, Input Terminal Board, Speakers
10 [XA] 10 [EX, EK, EF, EH, EB] 10 [XL]	SGP2750-1A SGP2750-2A SGP2750-3A	Rear Panel Rear Panel Rear Panel
11	SJF4101	Terminal, Ground
12 [XL] 12 [EF, EH, EB, EX] 12 [EK] 12 [XA]	QFC1207MA SJA88 QFC1205M SJA111	AC Cord AC Cord AC Cord AC Cord
13 [EF, EH, EB, EX, XA] 13 [EK] 13 [XL]	SHR127 SHR129 SHR131	Bushing, AC Cord Bushing, AC Cord Bushing, AC Cord
14 15 16	SUV453 SKL261 SKU9310	Cover, Voltage Adjuster Switch Foot, Set Bottom Board
17 17 17 17	SJS5627 SJS5335 SJS5429 SJS5527	Connector, 6 pin Connector, 3 pin Connector, 4 pin Connector, 5 pin
18 19	SJT347 SJS9221 SGT24750 SGT24770 SGT24790	Fuse Clamp AC Outlets Name Plate Name Plate Name Plate

Ref. No.	Part No.	Part Name & Description
SCREWS, WASHERS and NUTS		
N1 N2 N3 N4 N5 N6 N7 N8 N9 N10	XTB3+8GFZ XTB3+8BFN XTB3+8BFZ SNE4021 SNE59-1 XNS12 XWC6B XNGR6 XWA3BFZ XSN3+6BVS	Screw, Tapping, \oplus 3x8 Screw, Tapping, \oplus 3x8 Screw, Tapping, \oplus 3x8 Nut Washer Washer Washer Washer Washer Washer Screw, Tapping, \oplus 3x6
ACCESSORIES		
A1 [EX, EF, EH, EB] A1 [EK, XL] A1 [XA]	SQF10819 SQF10821-1 SQF10823	Instructions Book Instructions Book Instructions Book
A2 [XA] A3 [XA]	SJP5215 SJP5213-1	Plug Adapter, AC Power Plug Adapter, AC Power
PACKING PARTS		
P1 [EX, EK, XA, EH, EB] P1 [EF] P1 [XL]	SPG3213 SPG3211 SPG3215	Carton Box Carton Box Carton Box
P2 P2 [XL]	SPS3227 SPS3227-1	Pad, Left Pad, Left
P3 P3 [XL]	SPS3229 SPS3229-1	Pad, Right Pad, Right
P4	SPP691	Polyethylene Bag

