

Service Manual

Stereo Control Amplifier

SU-C1010

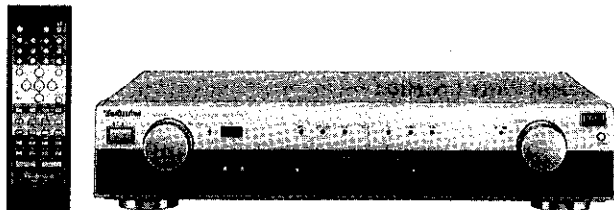

Colours

(K).....Black Type

(N).....Gold Type

Areas

(E).....Europe.

(EB).....Great Britain.

(EG).....Germany.

Specifications (DIN 45 500)

Input sensitivity/Impedance:

PHONO MM;	2.5 mV/47 k Ω
TUNER, CD, DVD-6CH, AUX, TAPE 1, TAPE 2/MD;	200 mV/22 k Ω

Total harmonic distortion (VGCA ON)

(Vol. MAX, 20 Hz – 20 kHz):

PHONO MM;	0.01 %
TUNER, CD, DVD-6CH, AUX, TAPE 1, TAPE 2/MD;	0.01 %

S/N (VGCA ON):

PHONO MM;	75 dB (77 dB, IHF '66)
TUNER, CD, DVD-6CH, AUX, TAPE 1, TAPE 2/MD;	104 dB (102 dB, IHF '66)
	112 dB (IHF A S=2 V rated output)

Frequency response (VGCA ON):

PHONO MM;	RIAA standard curve ± 0.8 dB (30 Hz – 15 kHz)
TUNER, CD, DVD-6CH, AUX, TAPE 1, TAPE 2/MD;	3 Hz – 100 kHz (+0 dB, -3 dB) +0 dB, -0.3 dB (20 Hz – 20 kHz)

Phono maximum input voltage (1 kHz, RMS):

MM; 85 mV (IHF '66)

Tone controls (VGCA OFF):

BASS;	+10 dB, -10 dB (50 Hz)
TREBLE;	+10 dB, -10 dB (20 kHz)

Muting:

$-\infty$ dB

Output voltage:

TAPE 1, TAPE 2 REC OUT;	200 mV
PRE OUT;	1 V

■ GENERAL

Power supply:

(E) and (EG) areas;	AC 50 Hz, 230 V
(EB) area;	AC 50 Hz, 230 – 240 V

Power consumption:

STANDBY;	12 W
Charging with STANDBY;	1 W
	6 W

Dimensions (W x H x D):

430 x 91.5 x 300 mm

Weight:

3.8 kg

Notes:

- Specifications are subject to change without notice. Weight and dimensions are approximate.
- Total harmonic distortion is measured by the digital spectrum analyzer.
- For (EB) area: The specification values given have been measured while using a 240 V-power supply.

⚠ WARNING

This service information is designed for experienced repair technicians only and is not designed for use by the general public. It does not contain warnings or cautions to advise non-technical individuals of potential dangers in attempting to service a product. Products powered by electricity should be serviced or repaired only by experienced professional technicians. Any attempt to service or repair the product or products dealt with in this service information by anyone else could result in serious injury or death.

Technics®

© 1999 Matsushita Electronic Industrial Co., Ltd. All rights reserved. Unauthorized copying and distribution is a violation of law.

CONTENTS

	Page		Page
1 Before Repair	2	9 Type Illustration of ICs, Transistors and Diodes	29
2 Protection Circuitry	2	10 Block Diagram	30
3 Accessories	2	11 Wiring Connection Diagram	32
4 Caution for AC Mains Lead	3	12 Measurement and Adjustment	33
5 Operations	4	12.1. Measurement instruments and Special tools	33
6 Operation Checks and Component Replacement Procedures	14	12.2. Output voltage Adjustment	33
7 Schematic Diagram	16	13 Terminal Function of ICs	34
7.1. Schematic Diagram Notes	16	13.1. IC701 (M38503M2404F) : Micro Computer	34
7.2. Schematic Diagram	17	14 Replacement Parts List	35
8 Printed Circuit Board Diagram	24	15 Cabinet Parts Location	40
		16 Packaging	42

1 Before Repair

1. Turn off the power supply. Using a 10 Ω, 10 W resistor, connect both ends of power supply capacitors (C651) in order to discharge the voltage.
2. Before turning the power supply on, after completion of repair, slowly apply the primary voltage by using a power supply voltage controller to make sure that the consumed

current at 50 Hz in NO SIGNAL mode should be shown below with respect to supply voltage 230/240 V.

Power supply voltage	AC 230 V, 50 Hz	AC 240 V, 50 Hz
Consumed current	20-34 mA	21-35 mA

2 Protection Circuitry

The protection circuitry may have operated if either of the following conditions is noticed:

- No sound is heard when the power is switched ON.
- Sound stops during a performance.

The functions of this circuitry is to prevent circuitry damage if, for example, the positive and negative speaker connection wires are shorted, or if speaker systems with an impedance less than the indicated rated impedance of this unit are used.

If this occurs, follow the procedure outlined below:

1. Switch OFF the power.
2. Determine the cause of the problem and correct it.
3. Switch ON the power once again.

Note:

When the protection circuitry functions, the unit will not operate unless the power is first switched OFF and ON again.

3 Accessories

- AC mains lead
(EB) area : (RJA0053-2X).....1 pc.
(E) and (EG) area : (RJA0019-X).....1 pc.

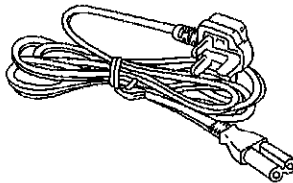

- Remote control transmitter
(RAK-SUA11WH).....1 pc.

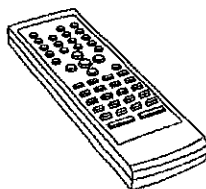

- Stereo phono cable
(SJP2276).....1 pc.

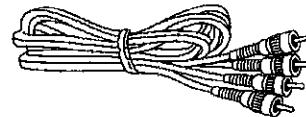

- Rechargeable battery
(P-06RM/8A13).....1 pc.

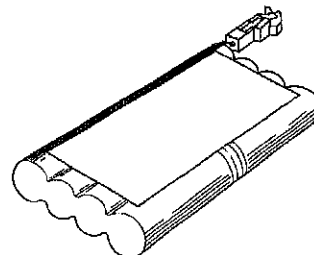

- Batteries for remote control transmitter (R6/LR6, AA, UM-3).....2 pcs.



Note: These are available on sales route.

4 Caution for AC Mains Lead (For United Kingdom)

(“EB” area code model only)

For your safety, please read the following text carefully.

This appliance is supplied with a moulded three pin mains plug for your safety and convenience.

A 5-ampere fuse is fitted in this plug.

Should the fuse need to be replaced please ensure that the replacement fuse has a rating of 5-ampere and that it is approved by ASTA or BSI to BS1362.

Check for the ASTA mark  or the BSI mark  on the body of the fuse.

If the plug contains a removable fuse cover you must ensure that it is refitted when the fuse is replaced.

If you lose the fuse cover the plug must not be used until a replacement cover is obtained.

A replacement fuse cover can be purchased from your local dealer.

CAUTION!

IF THE FITTED MOULDED PLUG IS UNSUITABLE FOR THE SOCKET OUTLET IN YOUR HOME THEN THE FUSE SHOULD BE REMOVED AND THE PLUG CUT OFF AND DISPOSED OF SAFELY. THERE IS A DANGER OF SEVERE ELECTRICAL SHOCK IF THE CUT OFF PLUG IS INSERTED INTO ANY 13-AMPERE SOCKET.

If a new plug is to be fitted please observe the wiring code as shown below.

If in any doubt please consult a qualified electrician.

IMPORTANT

The wires in this mains lead are coloured in accordance with the following code:

Blue: Neutral, Brown: Live.

As these colours may not correspond with the coloured markings identifying the terminals in your plug, proceed as follows:

The wire which is coloured Blue must be connected to the terminal which is marked with the letter N or coloured Black or Blue.

The wire which is coloured Brown must be connected to the terminal which is marked with the letter L or coloured Brown or Red.

WARNING: DO NOT CONNECT EITHER WIRE TO THE EARTH TERMINAL WHICH IS MARKED WITH THE LETTER E, BY THE EARTH SYMBOL  OR COLOURED GREEN OR GREEN/YELLOW.

THIS PLUG IS NOT WATERPROOF—KEEP DRY.

Before use

Remove the connector cover.

How to replace the fuse

The location of the fuse differ according to the type of AC mains plug (figures A and B). Confirm the AC mains plug fitted and follow the instructions below.

Illustrations may differ from actual AC mains plug.

1. Open the fuse cover with a screwdriver.

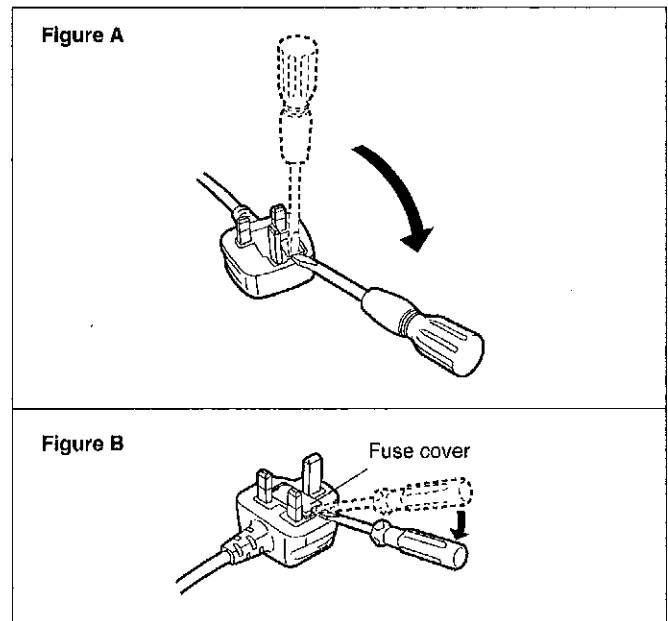

2. Replace the fuse and close or attach the fuse cover.

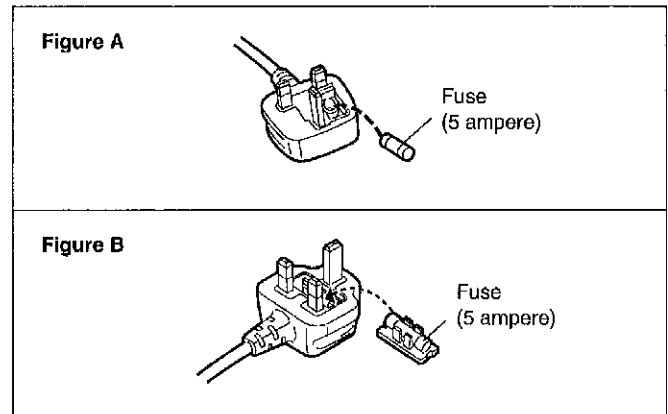

5 Operations

■ Front Panel Controls

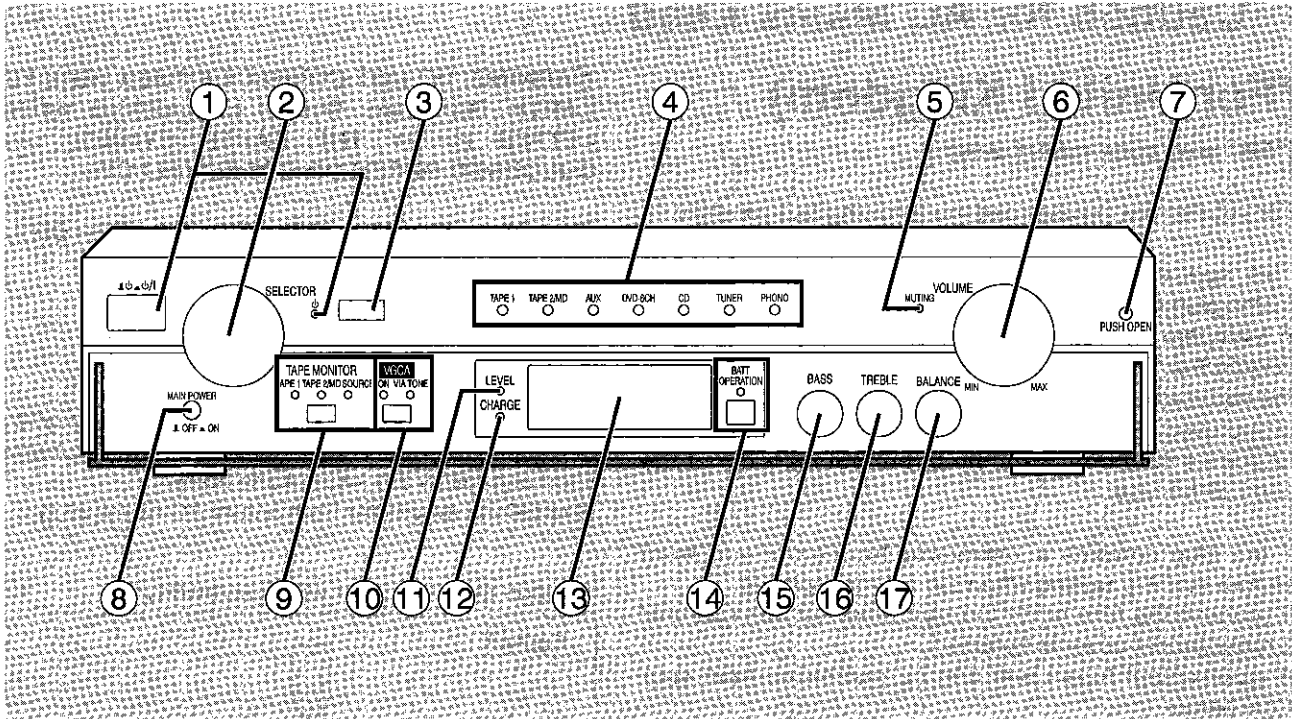

- | No. | Name |
|-----|---|
| ① | Unit on/off button (/) and remote standby indicator ()
Use this button to turn the unit on and off.
<ul style="list-style-type: none"> (off): The unit is in standby mode. (on): The unit is on. The unit can be turned on and off with the remote control. When the unit is turned off with the remote control it is in remote standby and the indicator lights. The unit is still using a small amount of power in the standby and remote standby conditions. Standby uses less power. |
| ② | Input selector (SELECTOR) |
| ③ | Remote control signal sensor |
| ④ | Input indicator |
| ⑤ | Muting Indicator (MUTING) |
| ⑥ | Volume control (VOLUME) |
| ⑦ | Panel button (PUSH OPEN)
Press to open the clear panel.
Close by hand. |

- | No. | Name |
|-----|--|
| ⑧ | Main power on/off button (MAIN POWER) |
| ⑨ | Tape monitor button/indicators (TAPE MONITOR) |
| ⑩ | VGCA button/indicators (VGCA) |
| ⑪ | Battery condition indicator (LEVEL) |
| ⑫ | Battery charge indicator (CHARGE) |
| ⑬ | Battery case |
| ⑭ | Battery operation button/indicator (BATT OPERATION) |
| ⑮ | Bass control (BASS) |
| ⑯ | Treble control (TREBLE) |
| ⑰ | Balance control (BALANCE) |

If the clear panel comes off

1. Insert the panel as shown in the illustration.
2. Ensure the panel is parallel to the unit, then press firmly down and in on the levers until they click into place.
3. Check that the panel now moves correctly.
If it does not, remove it and repeat the above procedure.

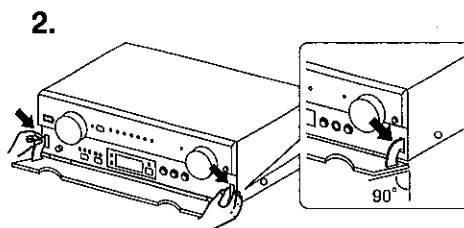
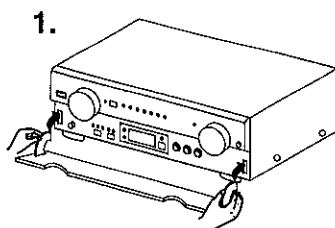

■ Inserting the Rechargeable Battery

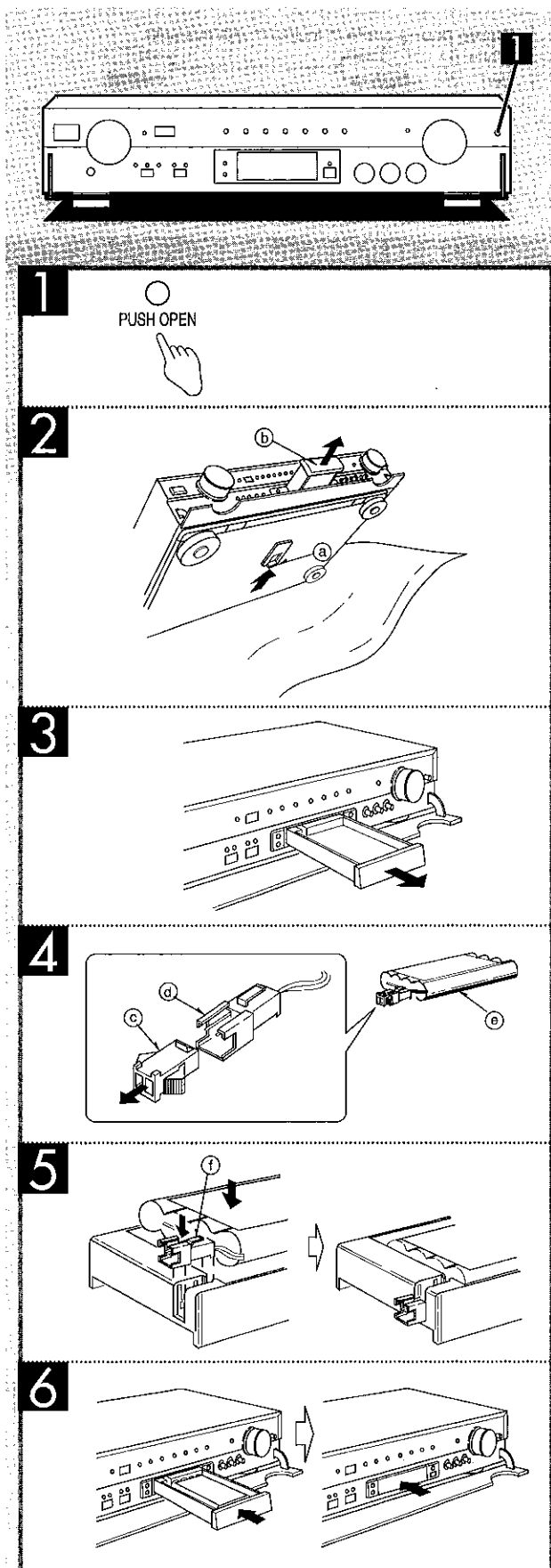

- Place the unit on top of a soft cloth to protect it from damage.
- Insert with the AC mains lead disconnected.

1 Press [PUSH OPEN] to open the clear panel.

2 Pull the lever (a) at the bottom of the unit toward you.
The battery case (b) will spring up by 1–2 cm.

3 Remove the battery case.

4 Remove the protective cap (c) from the connector (d) of the rechargeable battery (e) which is supplied as an accessory.
Keep the protective cap in a safe place.

5 Hold the connector so that the pawl (f) is facing upward, then securely insert the connector into the battery case groove until it snaps into place.
When taking the battery out of the case, be sure to lift the connector out first.

6 Insert the battery case into the main unit.
Ensure it is completely inserted.

Note

- Do not insert anything other than the rechargeable battery into the battery compartment.

For your reference

You can still use the unit with AC power even if the rechargeable battery isn't inserted.

■ Connections

- Make sure that the AC mains lead for all components has been turned off before making any connections.
- Connect the power cord to the amplifier only after all other connections between components have been made.

Note

Do not put this unit on units that produce heat, such as a power amplifier, as this can damage the rechargeable battery.

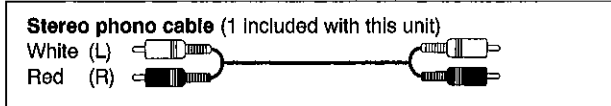

Connection to a power amplifier

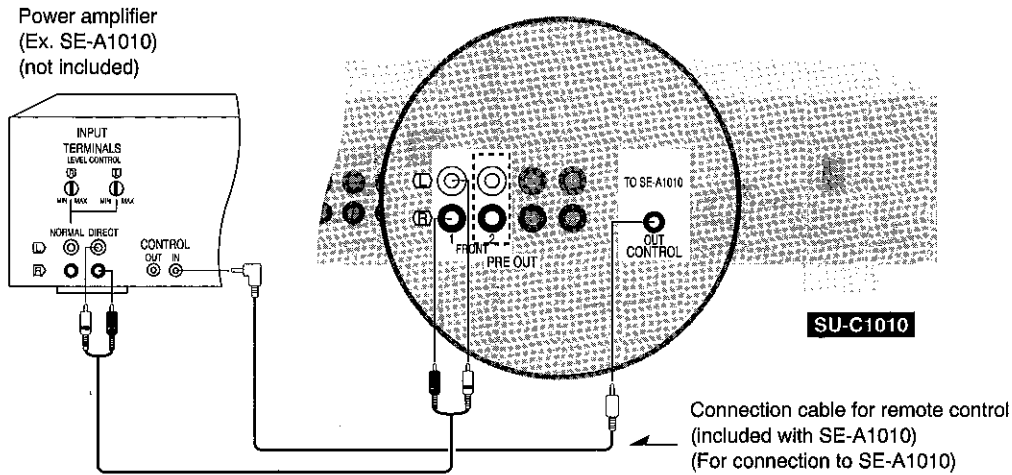

“PRE OUT FRONT 2” terminals:

These terminals let you connect a second power amplifier. To improve the sound quality, connect two Technics SE-A1010 power amplifiers to this unit. For details, see SE-A1010 Operating instructions.

When connecting a graphic equalizer

Connect it between the PRE OUT FRONT terminals of this unit and the INPUT terminals of the power amplifier.

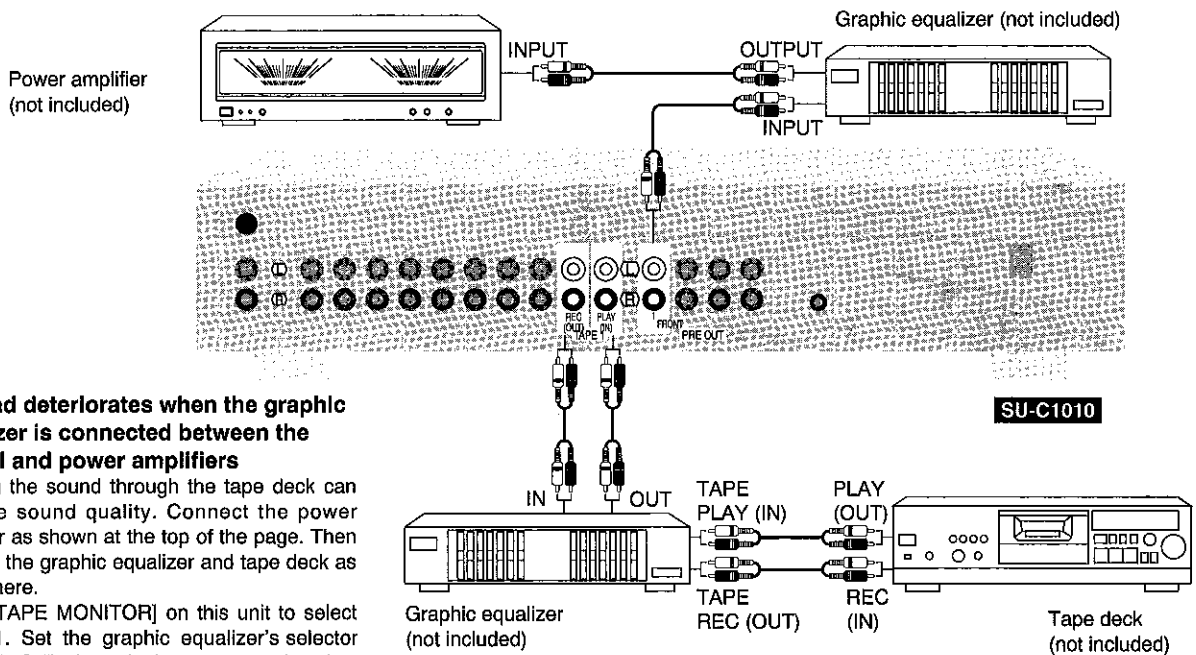

If sound deteriorates when the graphic equalizer is connected between the control and power amplifiers

Passing the sound through the tape deck can improve sound quality. Connect the power amplifier as shown at the top of the page. Then connect the graphic equalizer and tape deck as shown here.

Press [TAPE MONITOR] on this unit to select TAPE 1. Set the graphic equalizer's selector to "SOURCE" when playing sources other than the tape deck used in this connection (see the graphic equalizer's manual for details).

Connections to other equipment

See "Connecting a DVD player" for DVD player connection details.

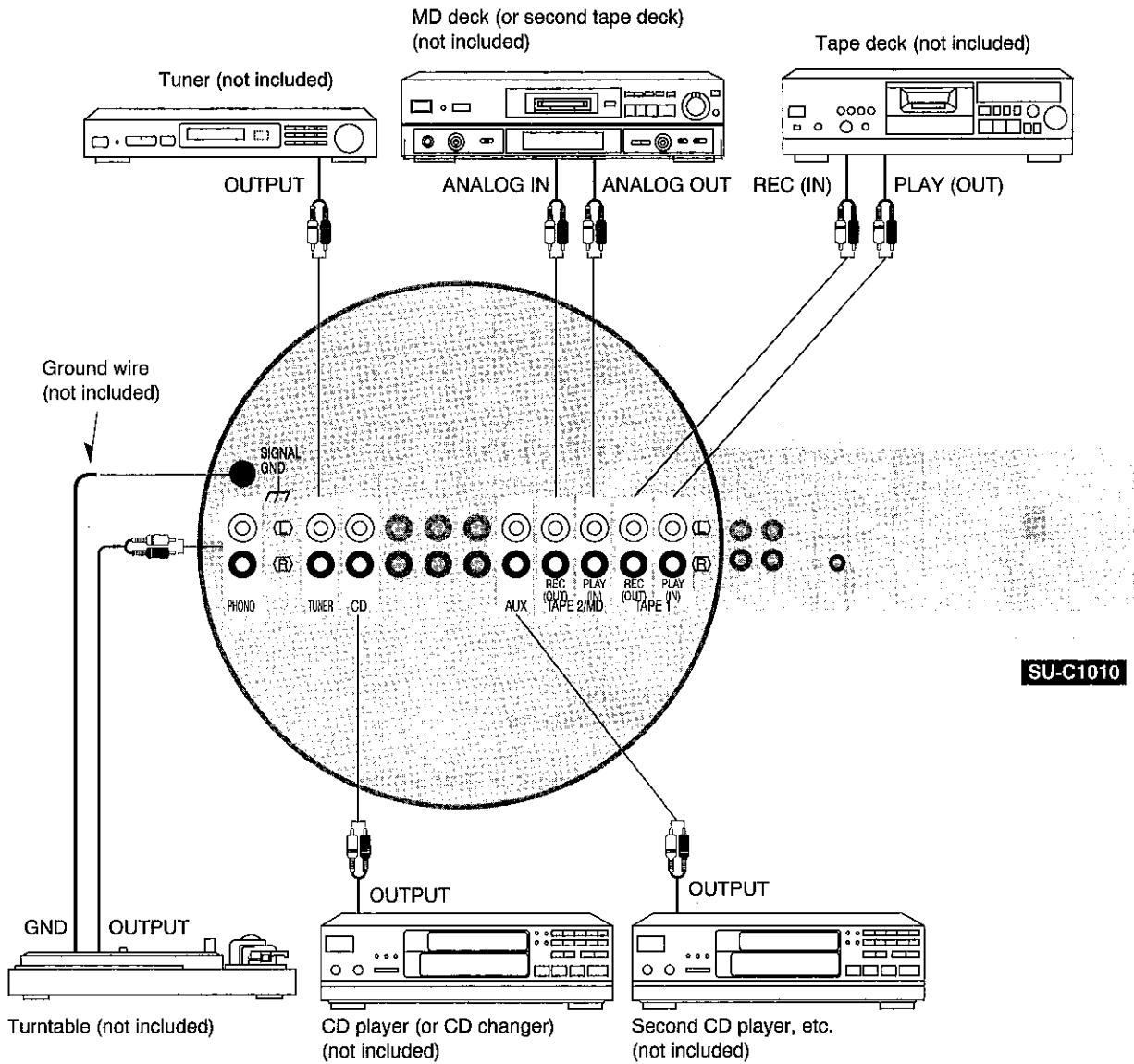
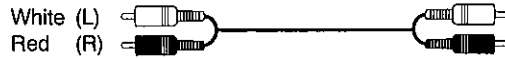

Stereo phono cable



Connecting a DVD player

Connect the DVD player to the TV with a video connection cable.

Stereo phono cable (1 included with this unit)

White (L) 
 Red (R) 

• 6 channel discrete connection

6 channel discrete connection enables you to enjoy the sound field effects recorded on DVDs.

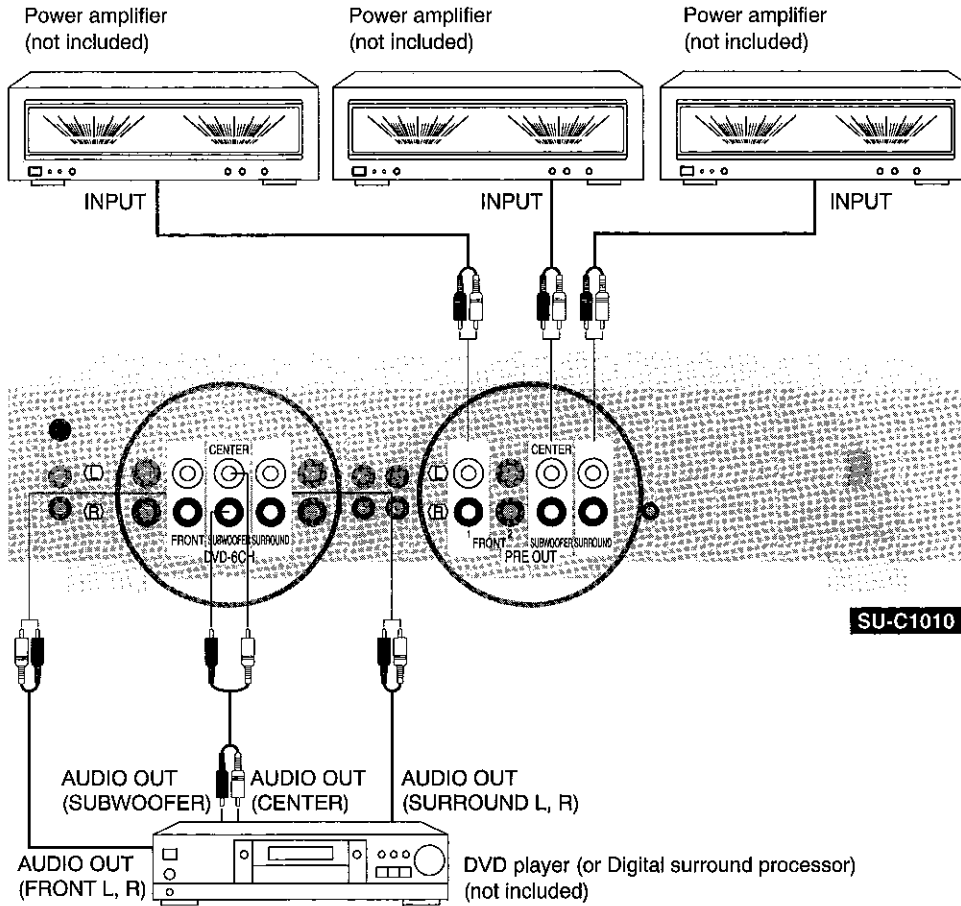

• 2 channel (stereo) connection

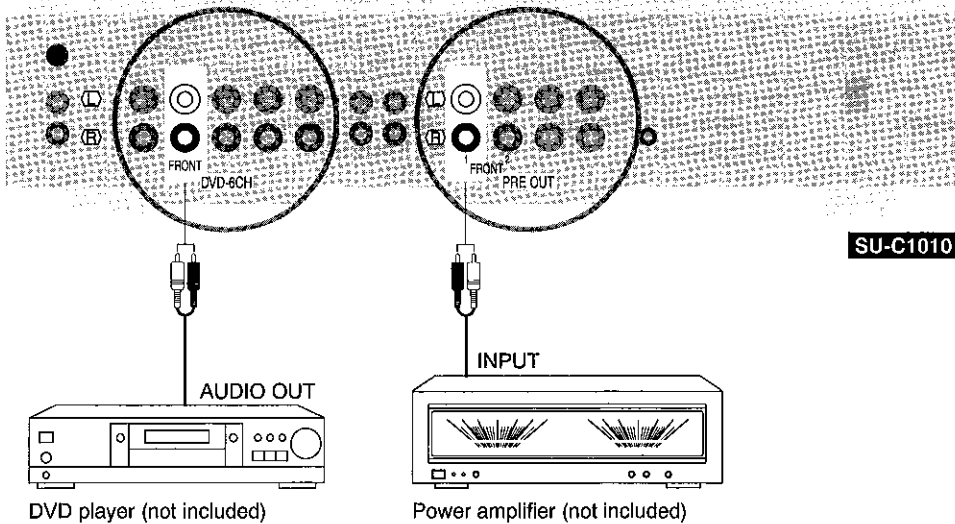

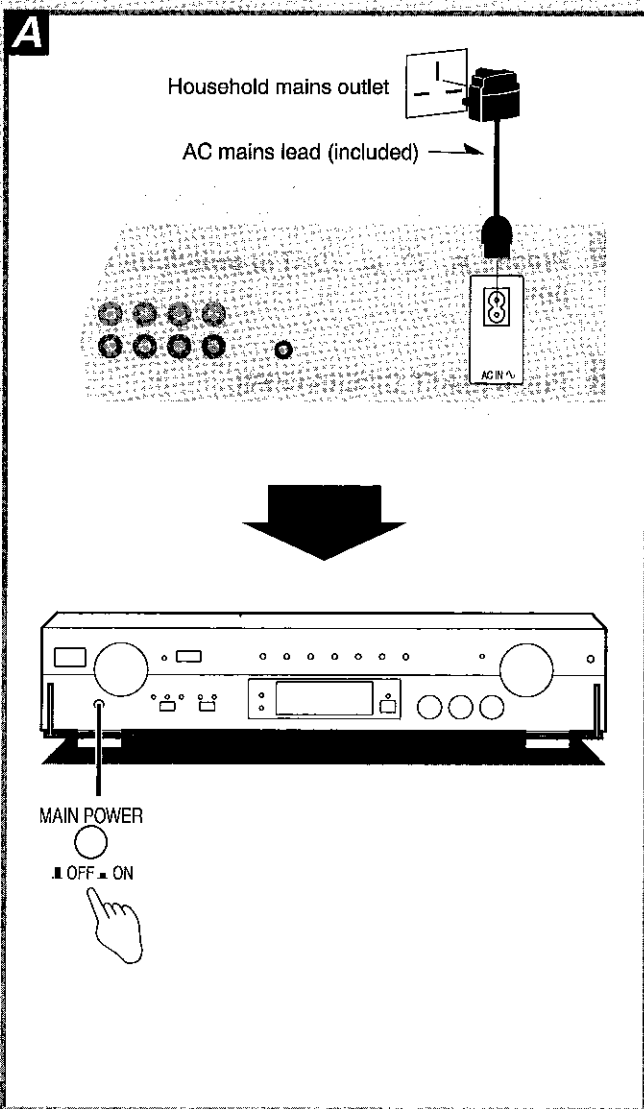

Connecting the power supply A

BE SURE TO READ THE CAUTION FOR THE AC MAINS LEAD BEFORE THE FOLLOWING CONNECTION.

Connect the power supply only after all other connections have been made.

Insertion of Connector

Even when the connector is perfectly inserted, the front part of the connector juts out as shown in the drawing. However there is no problem using the unit.

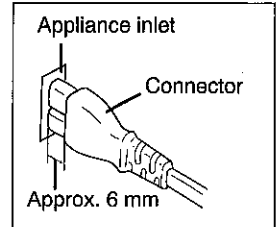

After connecting the AC mains lead
Press [MAIN POWER] to "ON".

Recharging the Battery B

First insert the rechargeable battery.
 (→ Refer to "Inserting the rechargeable battery".)

This unit's recharging system

There are two types of recharging.

Initial recharging

Initial recharging takes place when the battery is used for the first time, and when the battery case is taken out and inserted again. It takes about 10 hours for the battery to recharge and battery power cannot be used during this time. The unit can still be used on AC power during recharging.

Automatic recharging

The battery is recharged automatically when [MAIN POWER] is switched to "ON" after the battery has been used for a total of over about eight hours.

Recharging requires 1 hour for every 2 hours the unit was used.

The unit can use battery power even if automatic recharging is incomplete, but recharging stops as soon as operation is started.

Recharging

Initial recharging starts as soon as [MAIN POWER] is switched to "ON" after the battery has been inserted for the first time. "CHARGE" lights up.

No special steps are required to start recharging once the battery has been inserted.

Note

Leave the battery case in place unless you are replacing the battery or removing it for storage during non-use periods.

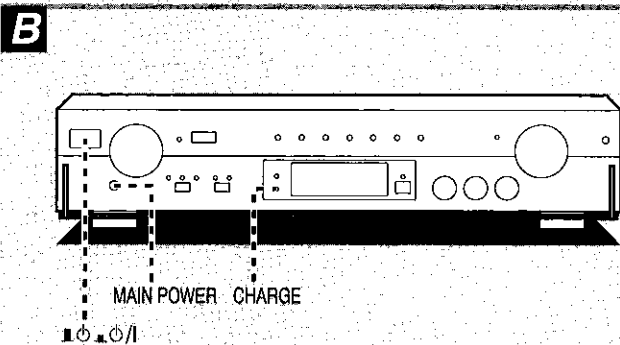

■ Using Battery Power

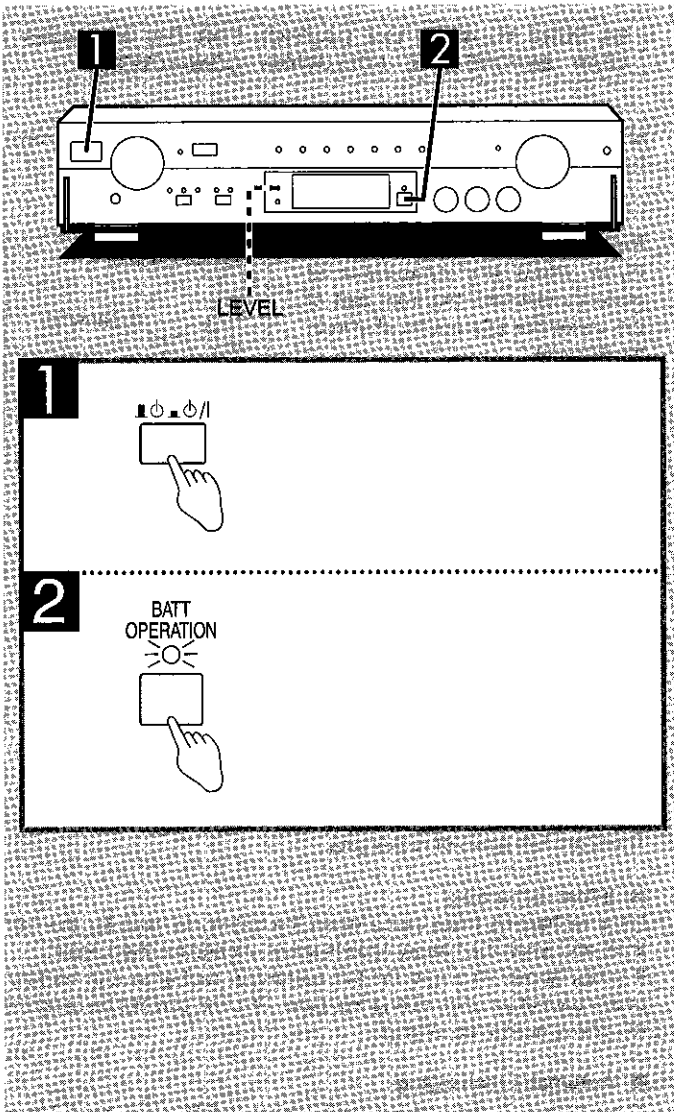

Noise can occur when audio equipment is used on AC power. This noise can be cut out by using battery power, thus enabling a much clearer sound.

Battery power can be used once initial recharging has been completed (→ refer to "Recharging").

1 Press [] to switch on the power.

2 Press [BATT OPERATION].
The indicator above the button lights and battery operation begins.

After this, carry out the steps on the following pages.

Turning the unit off

Press [] to " ".

Battery operation stops when the unit is turned off. The unit cannot operate solely on battery power.

When the unit is turned off in this fashion, the next time you press [] to switch to " ", the unit immediately starts operating on battery power.

Switching to AC power

Press [BATT OPERATION] to turn the indicator off.

For your reference

When the unit is used on battery power without recharging for about 15 hours and the voltage falls to a certain level, the unit automatically switches to AC power and initial recharging starts. The "BATT OPERATION" indicator goes out at this time. Playback and recording are not affected by this switch in power source.

If the "LEVEL" indicator is flashing

If you press [BATT OPERATION] and the "LEVEL" indicator flashes, initial recharging has not been completed and battery power is not yet available.

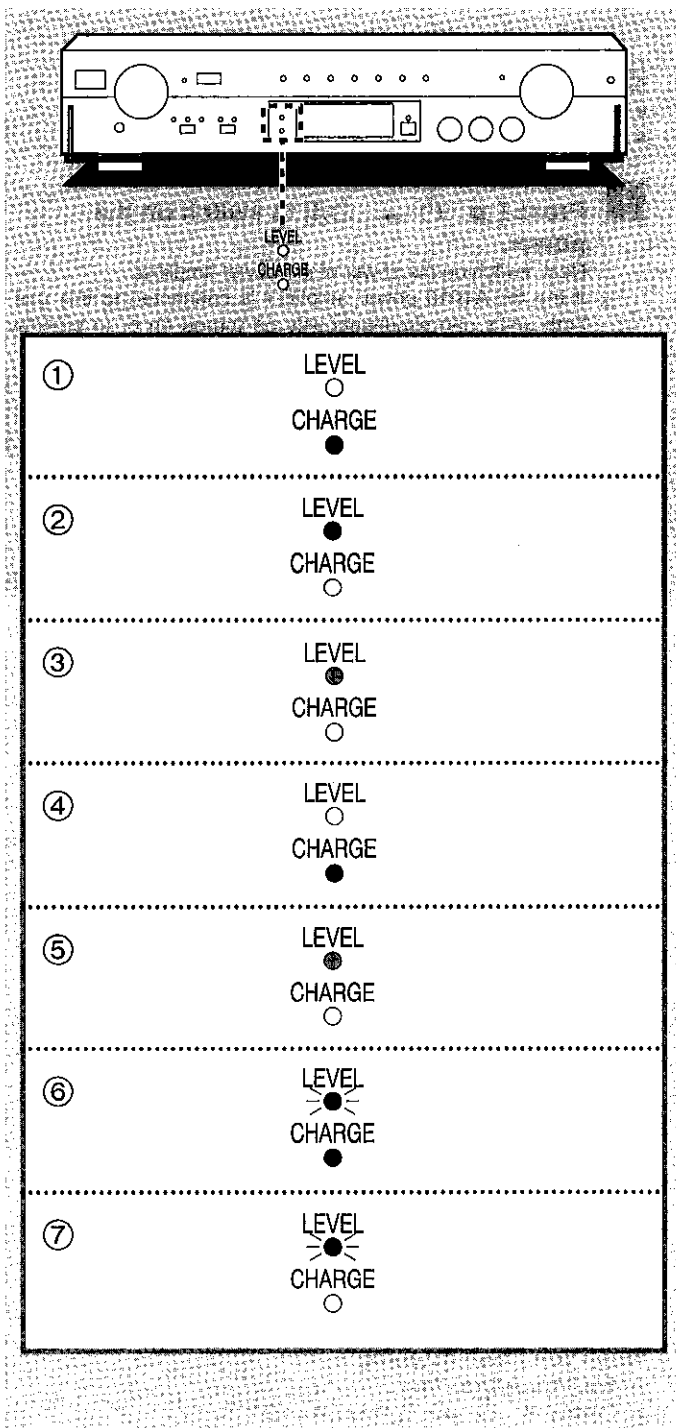

Checking the battery condition

The "LEVEL" and "CHARGE" indicators tell you whether the battery is in use, if it is recharging, and if it is running out of life.

When battery power is being used, each indicator changes as shown (① → ② → ③ → ④) during normal operation.

Lamp Indications

The following indicate the condition of the lamps

○ ...off ● ...on ☉ ...flashing

- ① **"CHARGE" is on**
Now initial recharging. Battery power cannot be used even when the unit is turned on. Once recharging is complete, "CHARGE" goes off and changes to ②.
- ② **"LEVEL" is green**
There is enough voltage in the battery.
Changes to ③ when the voltage goes down.
- ③ **"LEVEL" is orange**
The voltage in the battery is running out. Battery power can still be used. Changes to ④ when the unit is turned off and automatic recharging starts.
- ④ **"CHARGE" is on**
Now automatic recharging. Battery power can be used when the unit is turned on. Once recharging is complete, "CHARGE" goes off and changes to ②.
- ⑤ **"LEVEL" remains orange after recharging**
The battery is approaching the end of its useful life. Battery power can still be used.
- ⑥ **"CHARGE" is on and "LEVEL" flashes**
1) You tried to use battery power before initial charging was complete.
2) The battery has reached the end of its useful life.
- ⑦ **"CHARGE" is off and "LEVEL" flashes**
1) The battery hasn't been put into the battery case.
2) A problem has occurred with the unit's circuits.

Replacing the rechargeable battery

The operation life of the rechargeable battery is approximately two years. However, this depends on the conditions of use.

Note

Open the clear panel before removing the battery case.

■ Listening

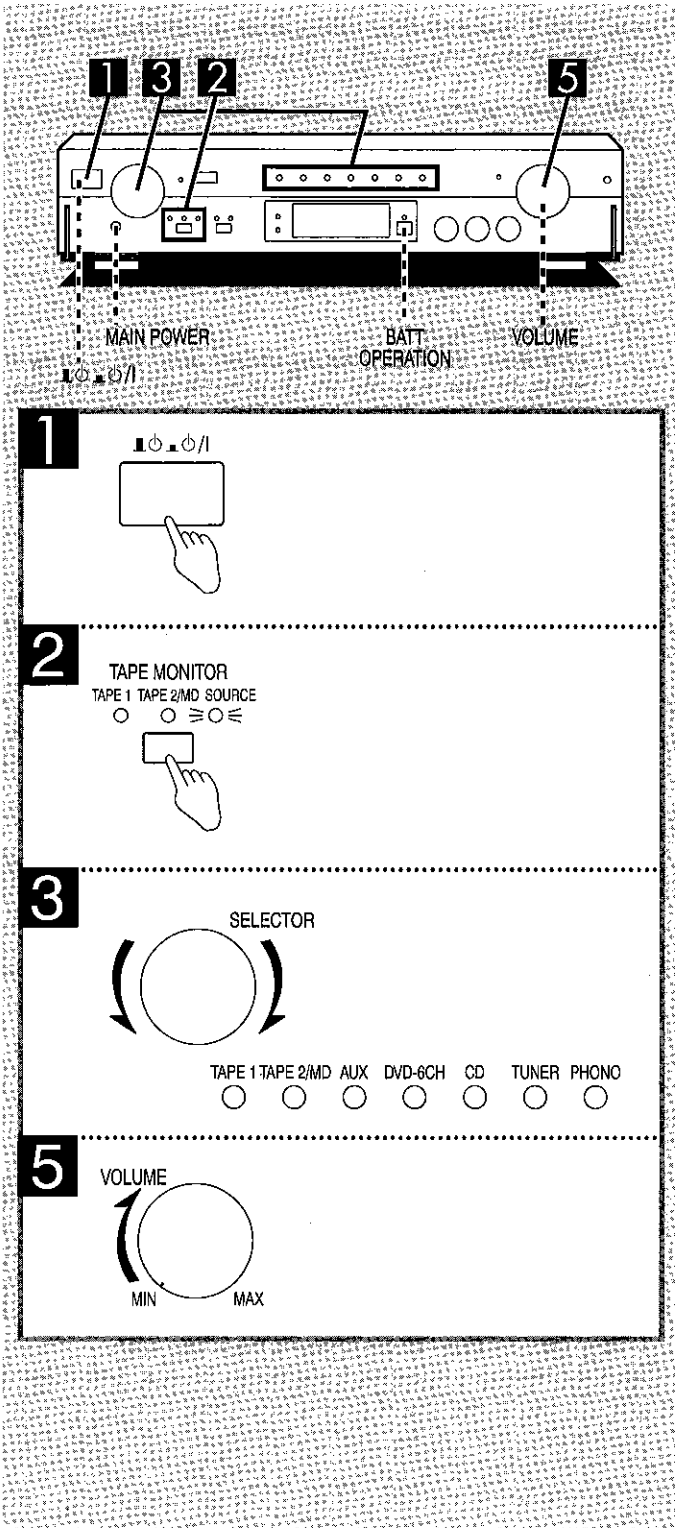

Preparation

- Press [MAIN POWER] to "ON".
- Before operation, set [VOLUME] to the "MIN" position.

1 Press [MAIN POWER] to switch on the power.

Next, switch on the power of the power amplifier. If the SE-A1010 power amplifier is connected to this unit, both unit's can simultaneously be turned on or to standby simply by pressing [MAIN POWER].

When you want to operate the unit on battery power, press [BATT OPERATION] to turn the indicator on.

2 Press [TAPE MONITOR] so that the "SOURCE" indicator lights up.

Each time the button is pressed, the indicator will change as follows.

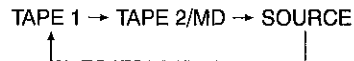

3 Turn [SELECTOR] to select the desired source.

The indicator which corresponds to the selected input source will light up.

- TAPE 1: Tape deck
- TAPE 2/MD: Second tape deck or MD deck
- AUX: Component connected to the "AUX" terminals
- DVD-6CH: DVD player
- CD: CD player (or CD changer)
- TUNER: Tuner
- PHONO: Turntable

4 Start the desired source.

Refer to the appropriate operating instructions for details.

5 Adjust the volume.

When you finish listening

1. Set [VOLUME] to "MIN".
2. Press [MAIN POWER] to "OFF".

The unit turns off.

If connected to a Technics SE-A1010 by a remote control cable, the SE-A1010 also turns off.

If this connection is not used, noise can be fed to the speakers when the control amplifier (this unit) is turned off. Avoid this by turning the power amplifier off first.

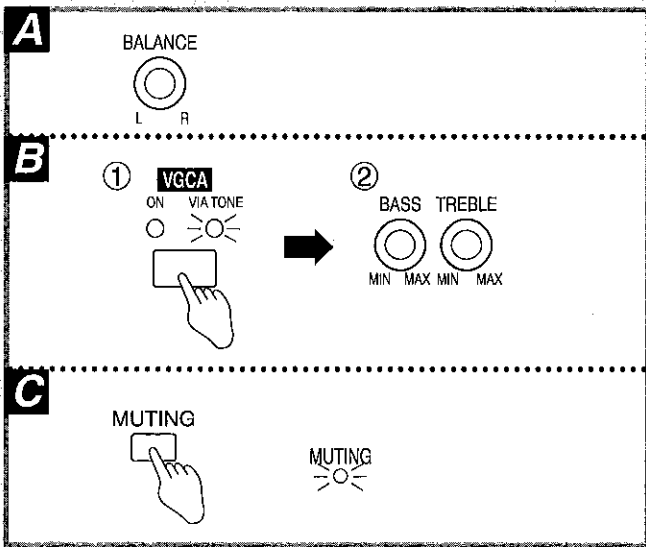
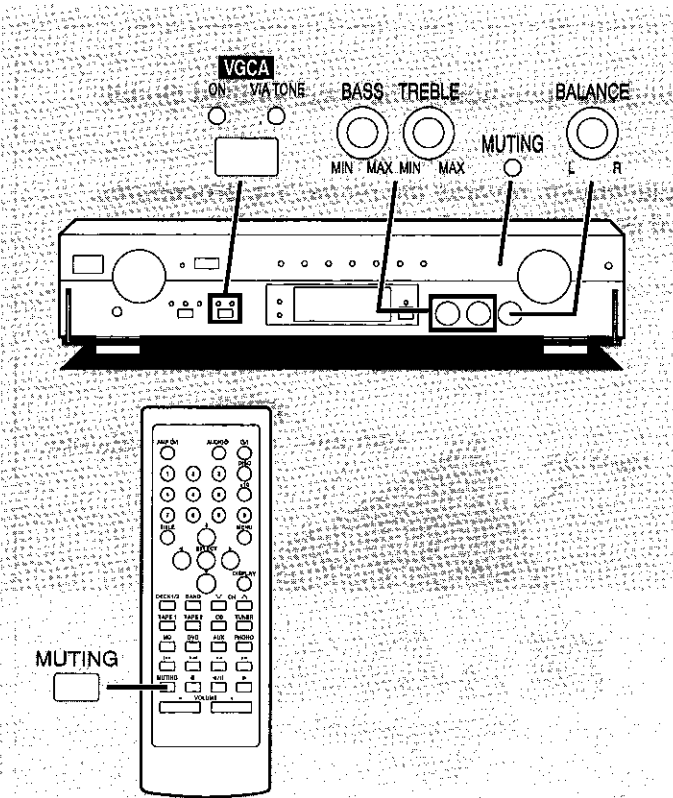

To adjust the sound balance **A**

Turn **[BALANCE]** to adjust the left/right sound balance.

The VGCA circuit

This unit features a state-of-the-art variable gain control amplifier (VGCA).

Rather than reducing the volume of the input signal and then amplifying it as was done in the past, this unit uses the VGCA circuit to change the gain of the amplifier itself.

This has resulted in a 10 dB improvement on the S/N ratio of past models.

Leave VGCA on during normal use.

VGCA is switched on at the time of purchase.

To adjust the tone quality **B**

- ① Press **[VGCA]** to turn the "VIA TONE" indicator on.
- ② Turn **[BASS]** to adjust the low-frequency sound. Turn **[TREBLE]** to adjust the high-frequency sound.

Press again to turn VGCA on again. Sound is heard unadjusted.

To mute the sound level **C**

Remote control only

Press **[MUTING]**.

The "MUTING" indicator on this unit will light up.

Press once again to return to the previous volume level. The "MUTING" indicator will turn off.

Note

Muting is also canceled when the unit is turned off.

6 Operation Checks and Component Replacement Procedures

- NOTE** 1. This section describes procedures for checking the operation of the major printed circuit boards and replacing the main components.
2. For reassembly after operation checks or replacement, reverse the respective procedures. Special reassembly procedures are described only when required.

1. Checking for the operation (1) P.C.B., tone P.C.B., pre out P.C.B. and main P.C.B.

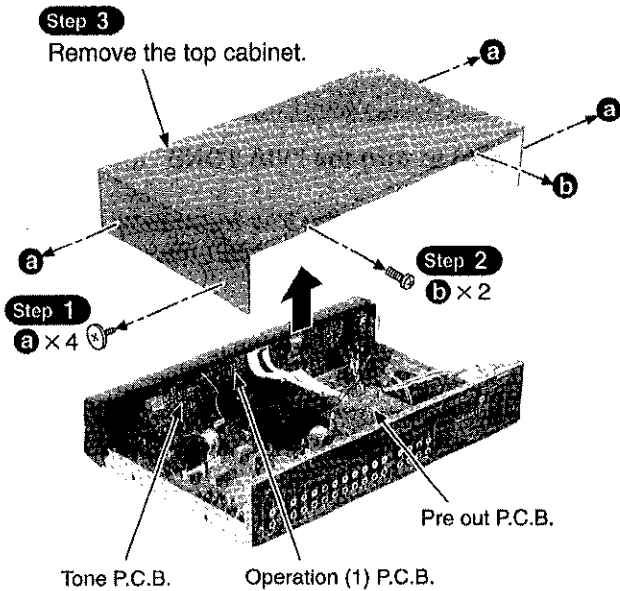

• Check the operation (1) P.C.B., tone P.C.B. and pre out P.C.B. as shown above

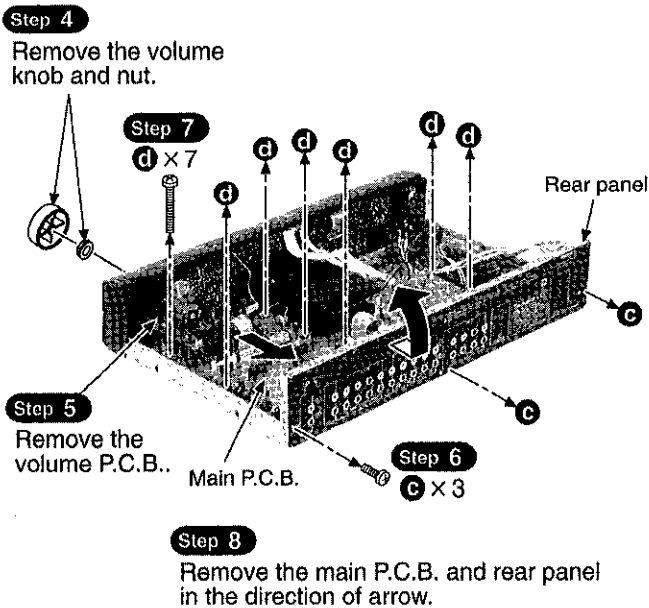

• Check the main P.C.B. as shown below.

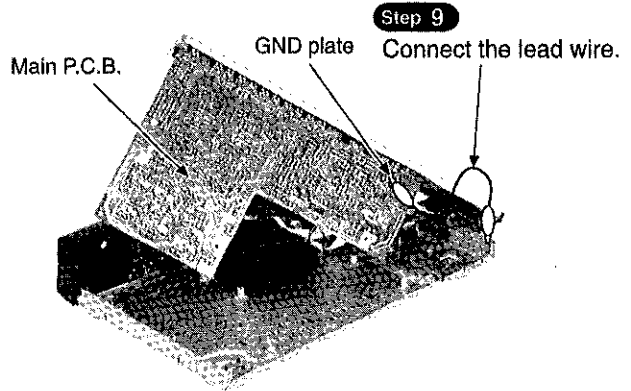

To remove each P.C.B.

• Follow the Step 1 ~ Step 3 of the item 1.

Step 1
Remove the 6 connectors.

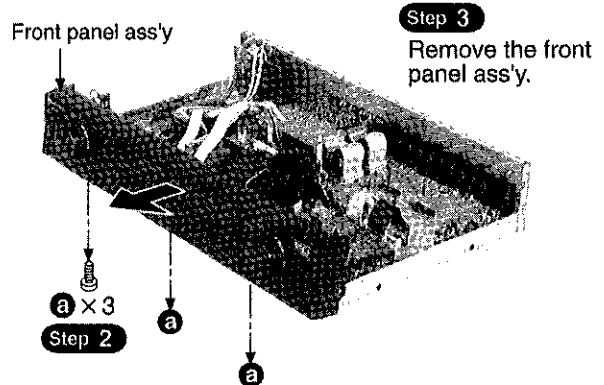
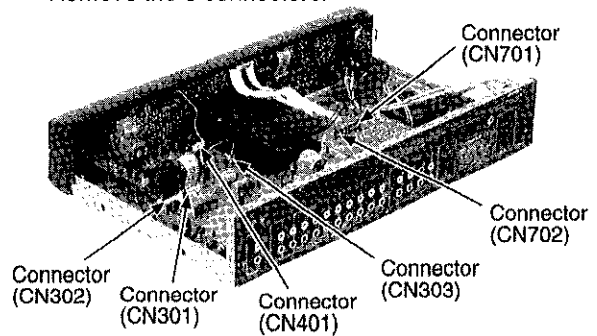

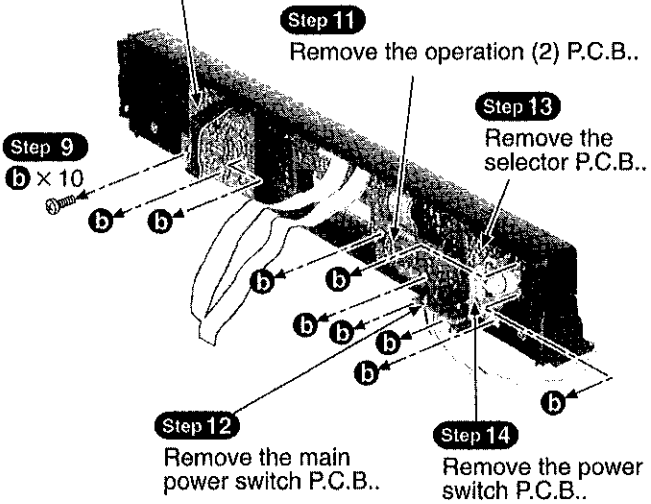
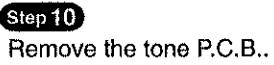
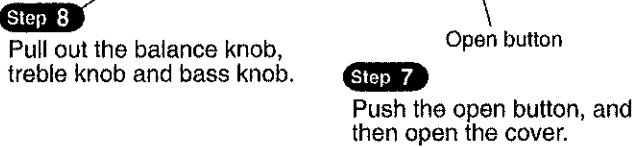
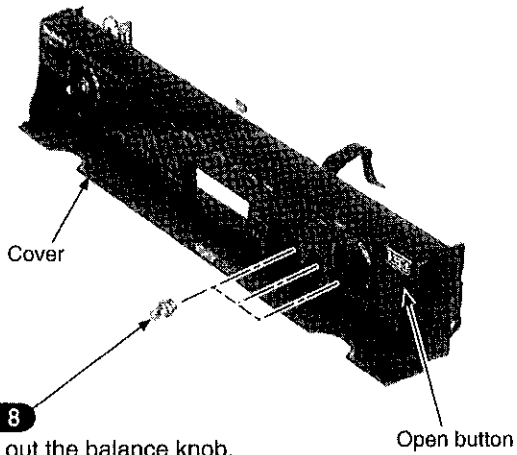
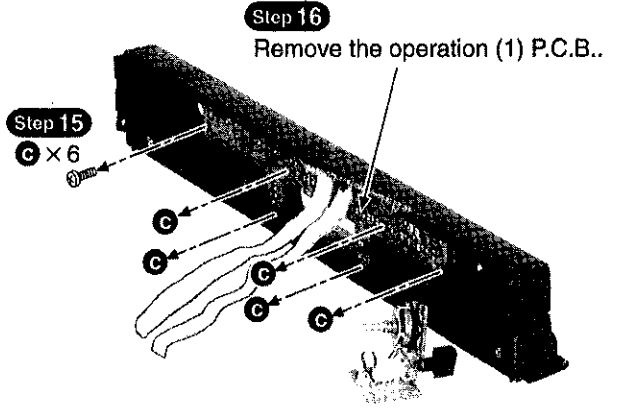
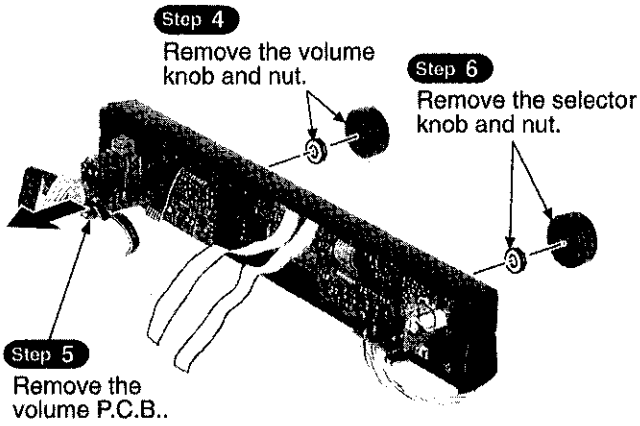



7 Schematic Diagram

7.1. Schematic Diagram Notes

- This schematic diagram may be modified at any time with the development of new technology.

Notes:

S1:	Main Power on/off switch (MAIN POWER)
S801:	VGCA switch (VGCA)
S802:	Tape monitor switch (TAPE MONITOR)
S803:	Battery operation switch (BATT OPERATION)
S804:	Input select switch (SELECTOR)
S805:	Unit on/off switch (   I)
VR301:	Volume control VR (VOLUME)
VR321:	Output voltage adjustment VR (L ch)
VR322:	Output voltage adjustment VR (R ch)
VR401:	Balance control VR (BALANCE)
VR402:	Bass control VR (BASS)
VR403:	Treble control VR (TREBLE)

- Indicated voltage values are the standard values for the unit measured by the DC electronic circuit tester (high-impedance) with the chassis taken as standard. Therefore, there may exist some errors in the voltage values, depending on the internal impedance of the DC circuit tester.

No mark : Power ON

- Important safety notice:

Components identified by  mark have special characteristics important for safety.

Furthermore, special parts which have purposes of fire-retardant (resistors), high-quality sound (capacitors), low-noise (resistors), etc. are used.

When replacing any of components, be sure to use only manufacturers specified parts shown in the parts list.

- **Caution!**

IC and LSI are sensitive to static electricity.

Secondary trouble can be prevented by taking care during repair.

Cover the parts boxes made of plastics with aluminum foil.

Ground the soldering iron.

Put a conductive mat on the work table.

Do not touch the legs of IC or LSI with the fingers directly.

- Voltage and signal line

 : Positive voltage line

 : Negative voltage line

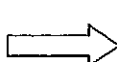
 : Phono signal line

 : Tape rec signal line

- **Forced Switching to Battery Power for Testing and Maintenance**

When the rechargeable battery is replaced or reinstalled, it remains in a state of charging for approximately 10 hours. While it is in this state, the power supply cannot be switched over to battery power by pressing the Battery Operation button. To forcibly switch to battery power, turn off the unit (with the Standby indicator on) and then back on again while holding down the Battery Operation button. The unit will switch to battery power and the Battery Operation indicator will light up. If the Battery Operation indicator does not light, there is a malfunction in the rechargeable battery or a circuit in the battery system.

7.2. Schematic Diagram

SCHEMATIC DIAGRAM-1

——— : POSITIVE VOLTAGE LINE
 - - - : NEGATIVE VOLTAGE LINE
 ⇨ : PHONO SIGNAL LINE

A MAIN CIRCUIT

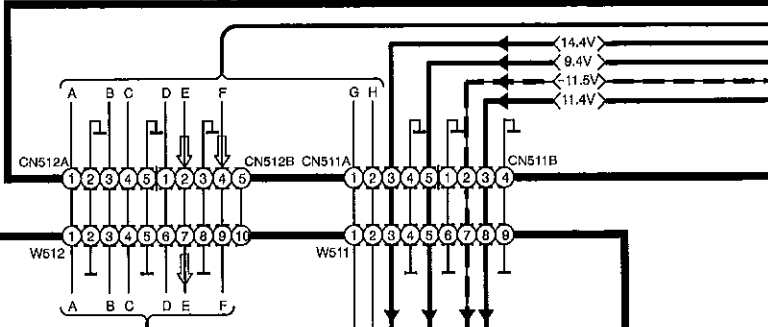

B PRE OUT CIRCUIT

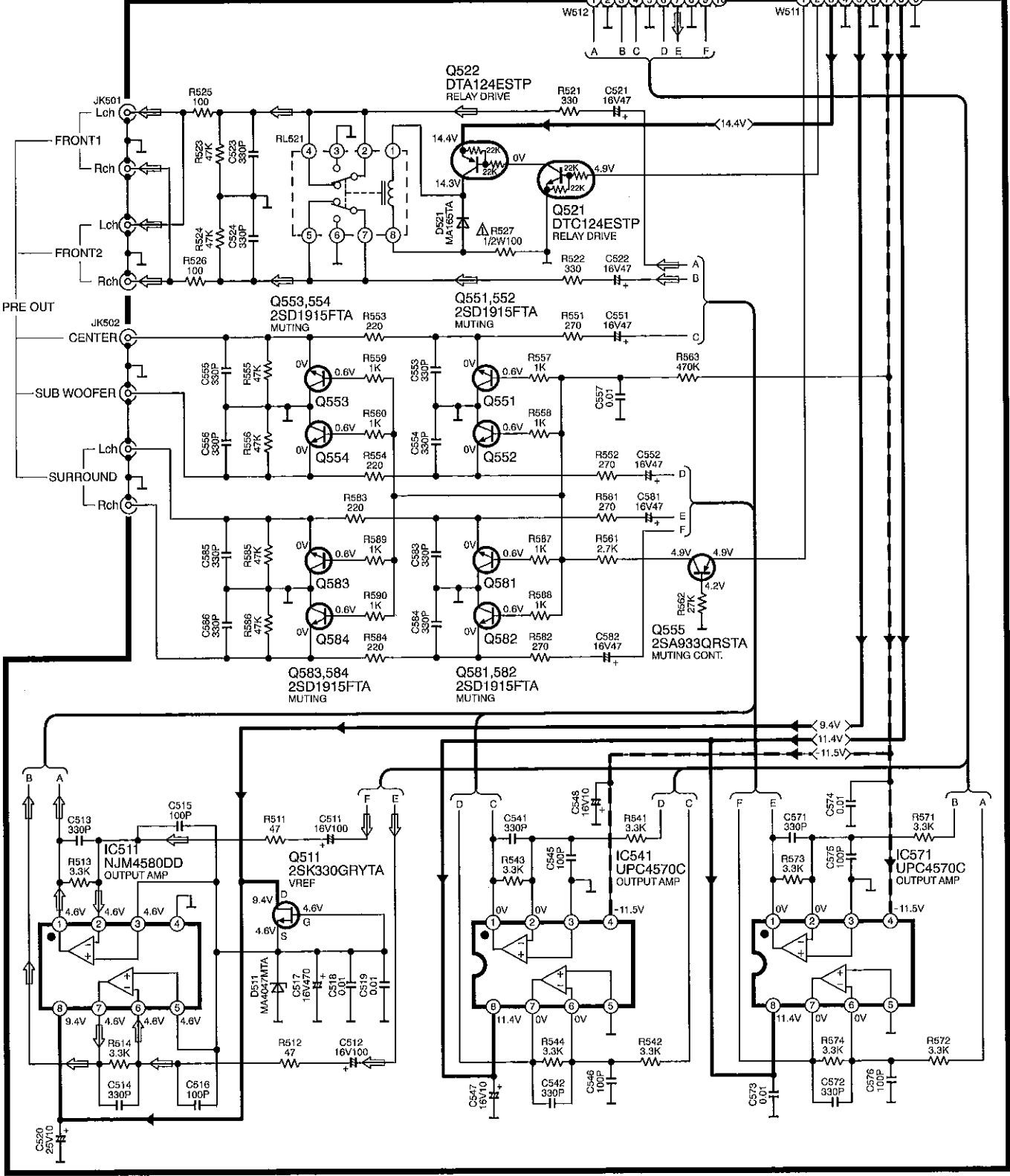

SCHEMATIC DIAGRAM-2

——— : POSITIVE VOLTAGE LINE ⇨ : PHONO SIGNAL LINE
 - - - : NEGATIVE VOLTAGE LINE ⇨ : TAPE REC SIGNAL LINE

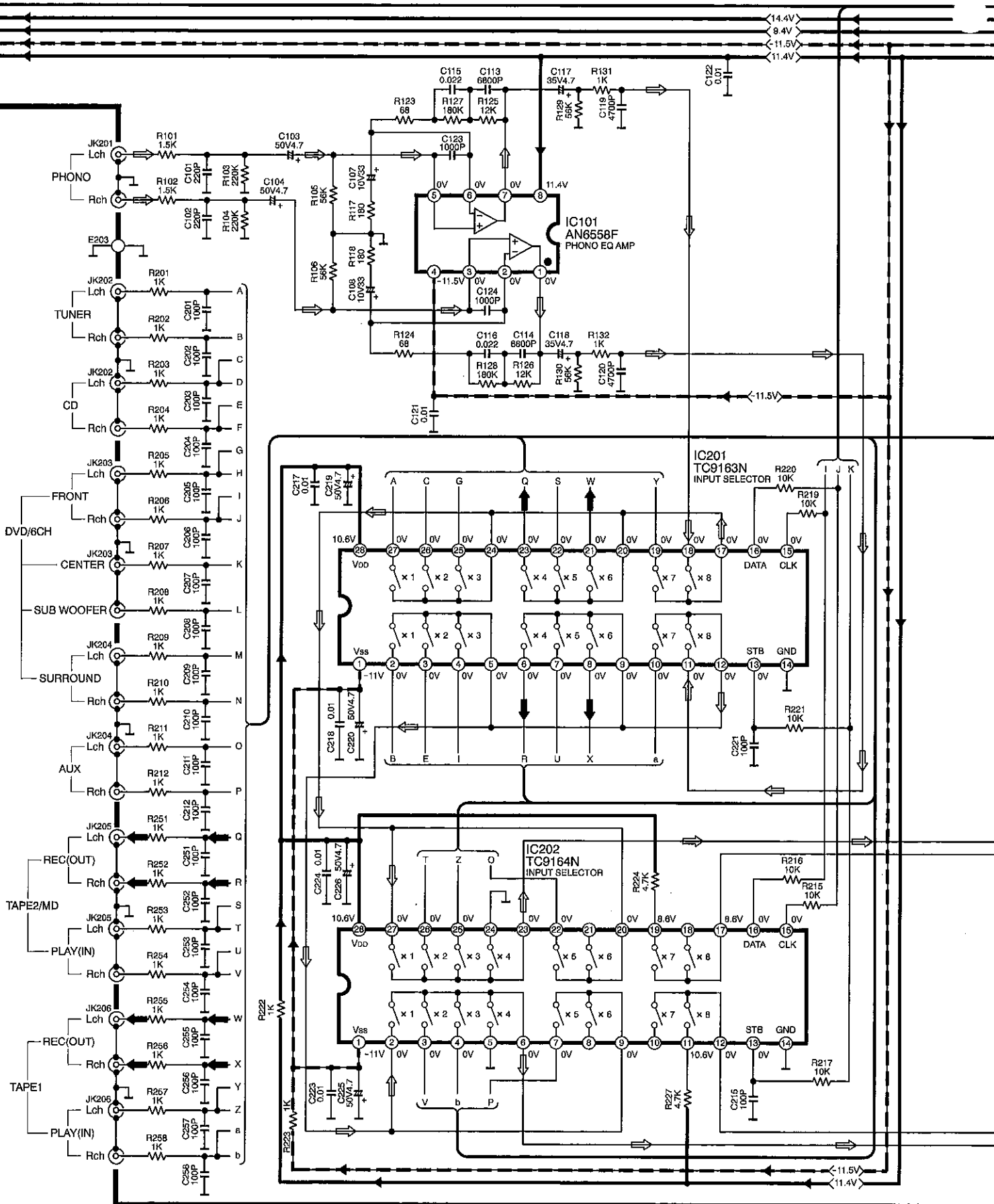

SCHEMATIC DIAGRAM-3

A MAIN CIRCUIT

→ : POSITIVE VOLTAGE LINE - - - - - : NEGATIVE VOLTAGE LINE ⇨ : PHONO SIGNAL LINE

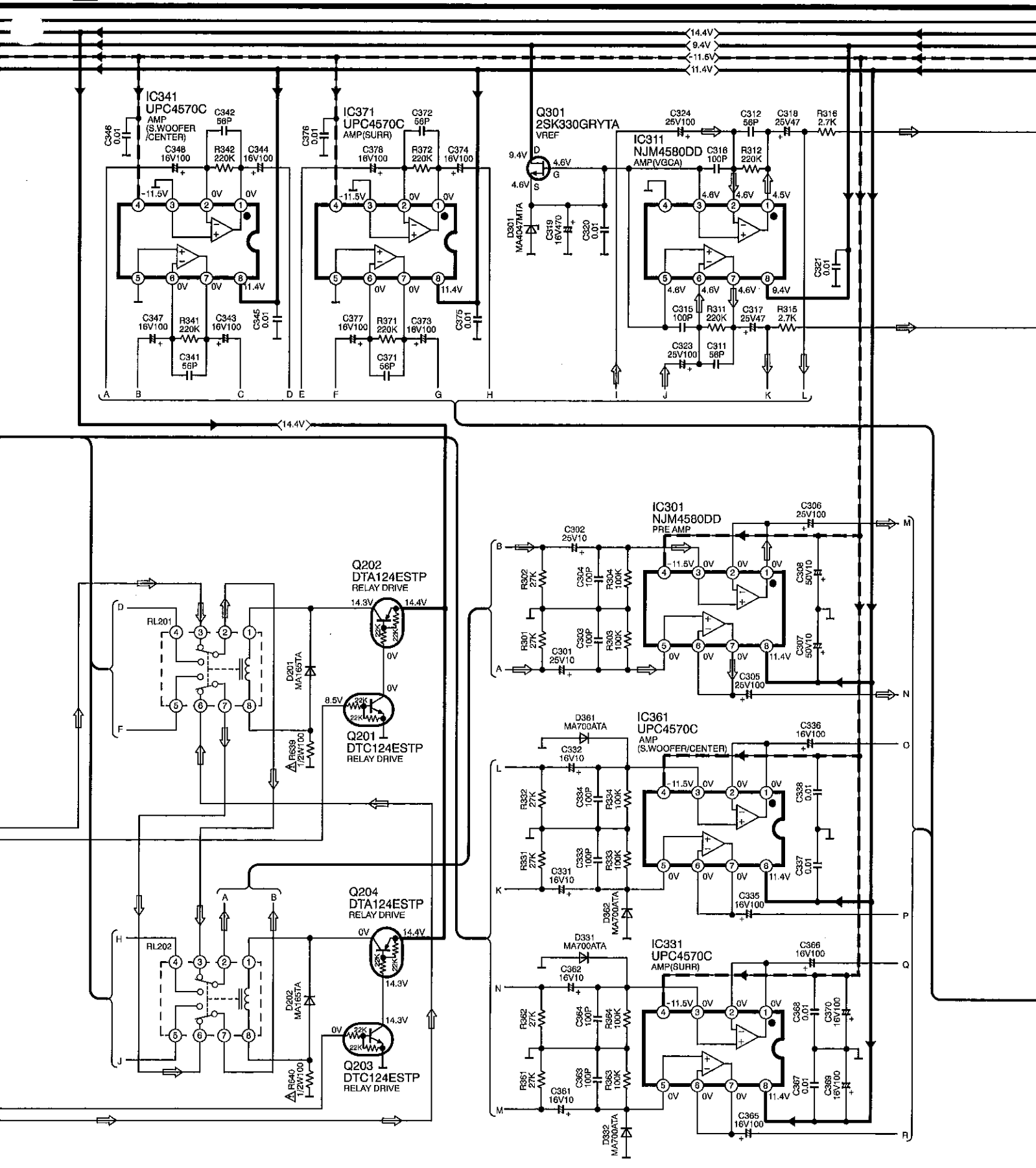

SCHEMATIC DIAGRAM-4

→ : POSITIVE VOLTAGE LINE - - - - - : NEGATIVE VOLTAGE LINE ⇨ : PHONO SIGNAL LINE

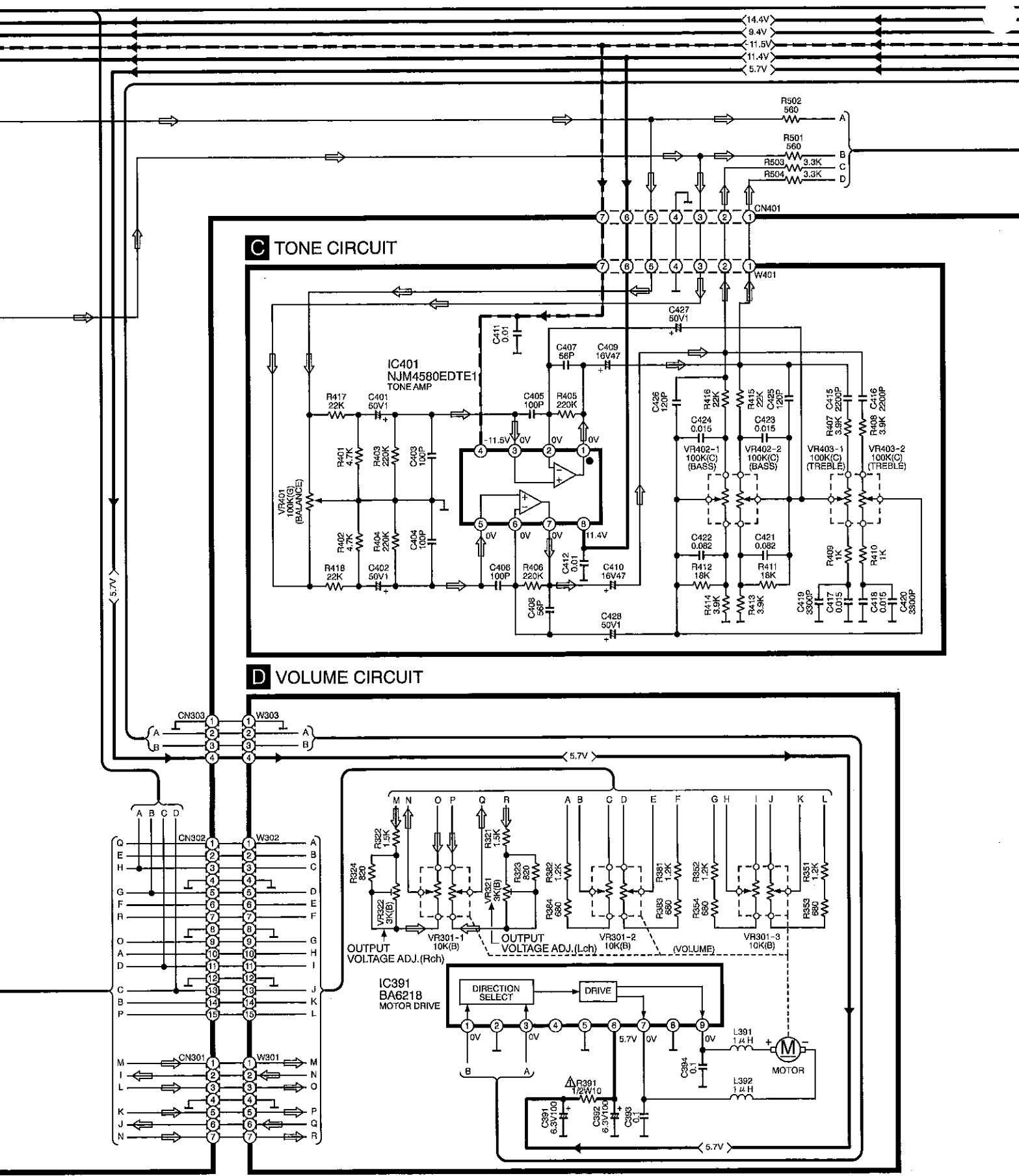

SCHEMATIC DIAGRAM-5

A MAIN CIRCUIT

→ : POSITIVE VOLTAGE LINE -> : NEGATIVE VOLTAGE LINE

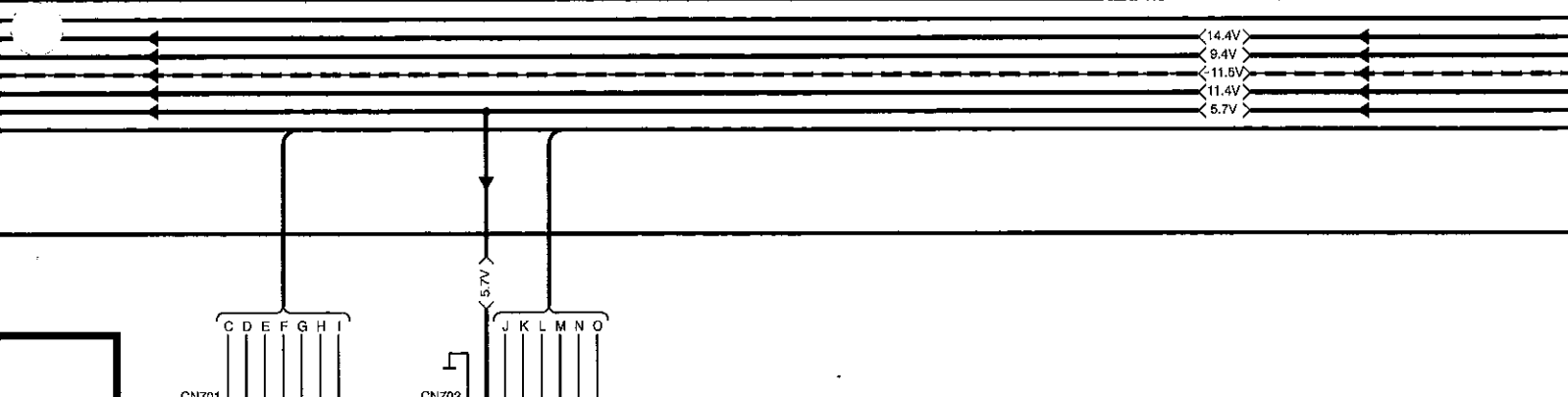

E OPERATION(1) CIRCUIT

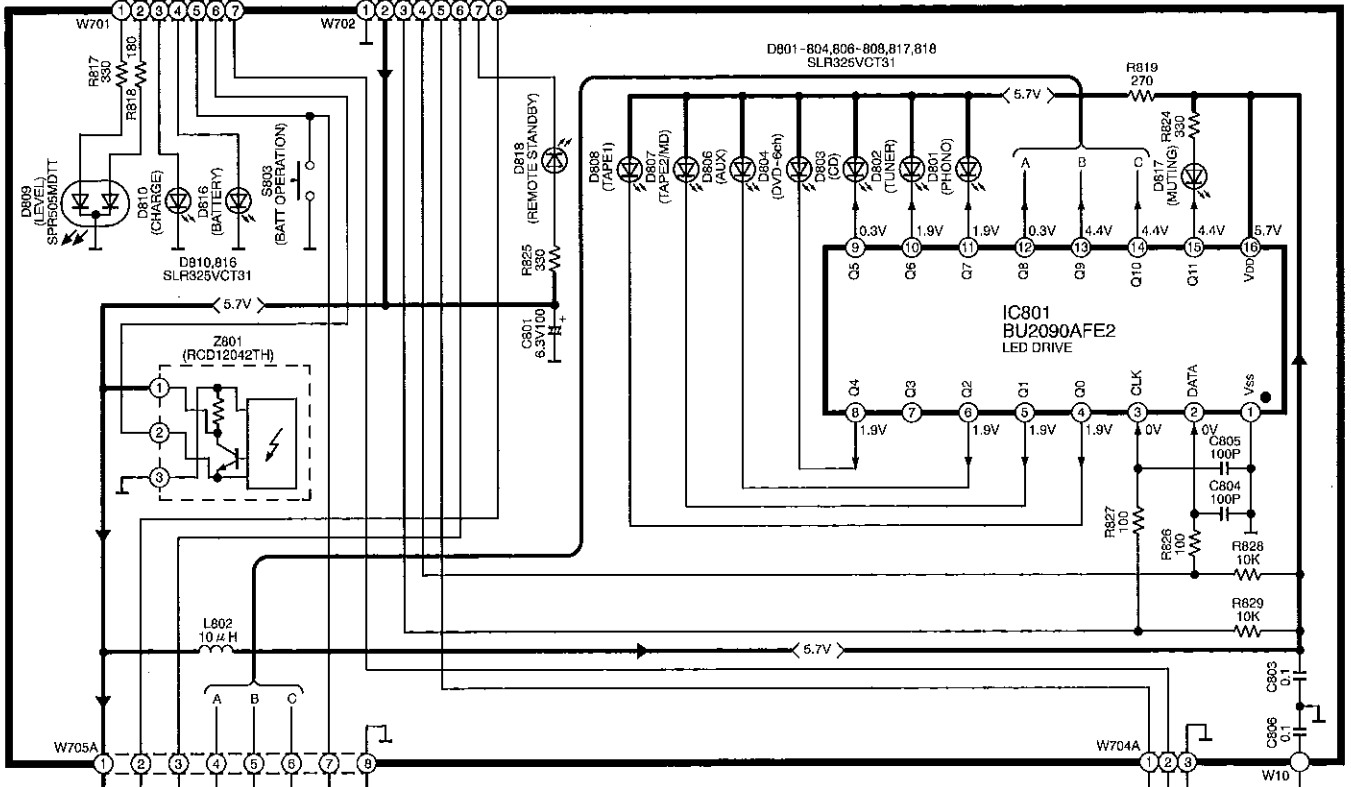

F OPERATION(2) CIRCUIT

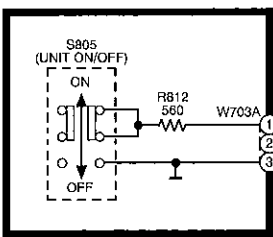
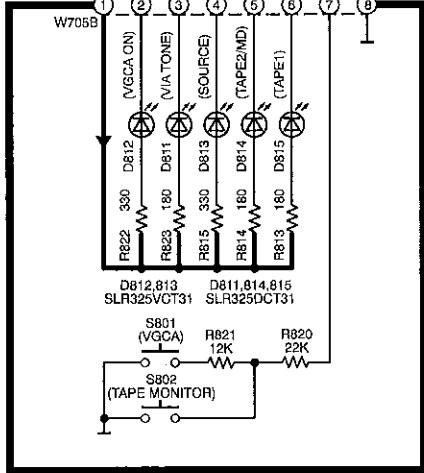

G POWER SWITCH CIRCUIT

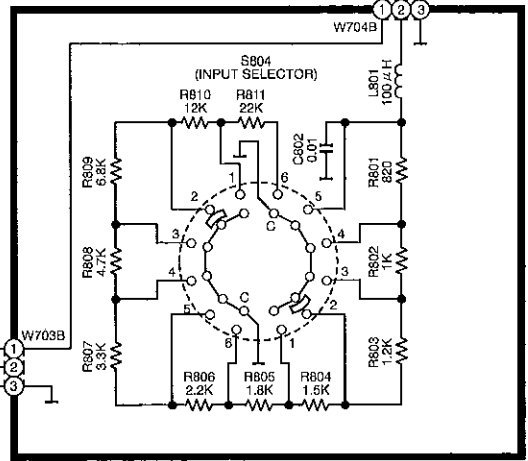

H SELECTOR CIRCUIT

SCHEMATIC DIAGRAM-6

→ : POSITIVE VOLTAGE LINE - - - - - : NEGATIVE VOLTAGE LINE ⇨ : PHONO SIGNAL LINE

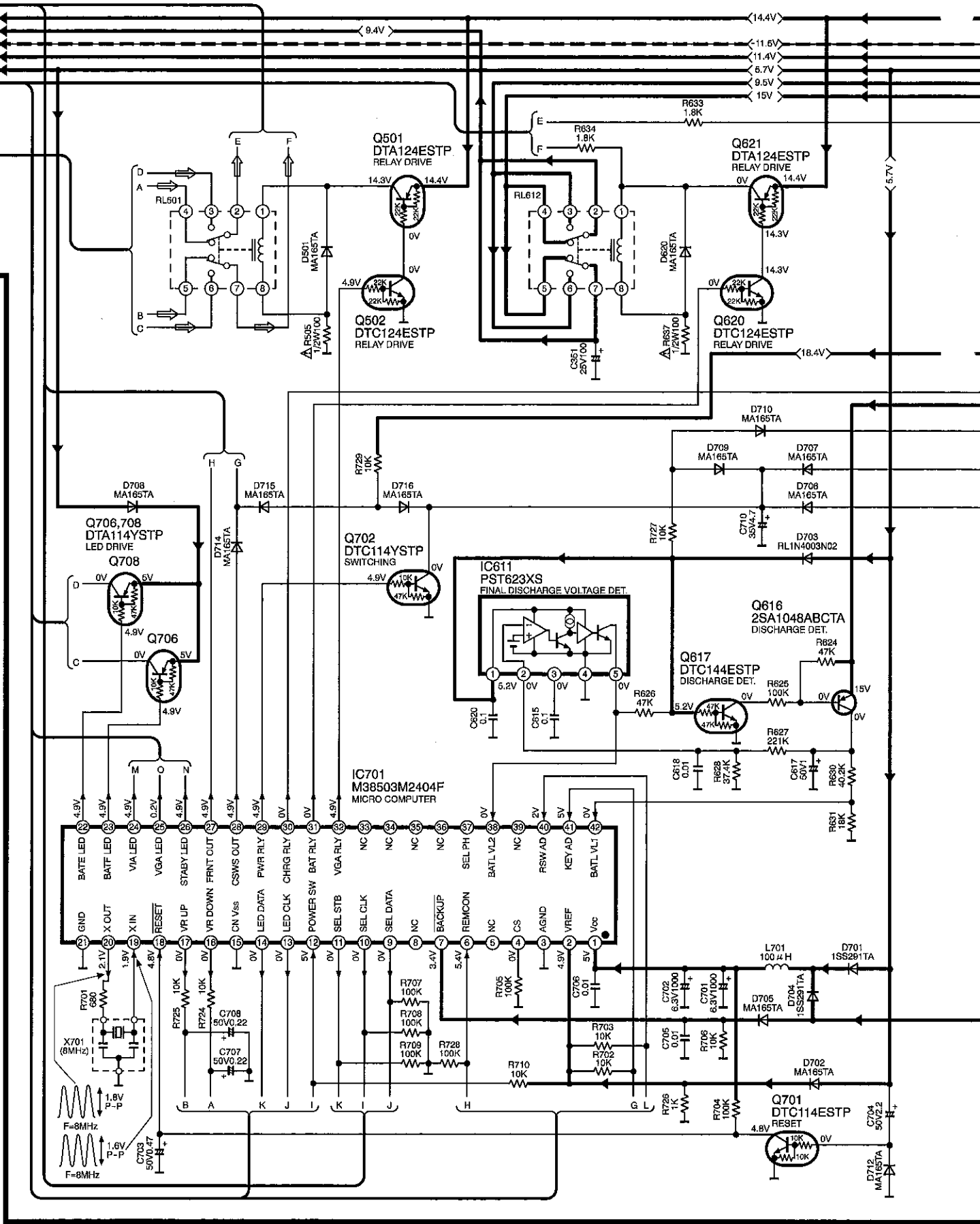

SCHEMATIC DIAGRAM-7

A MAIN CIRCUIT

→ POSITIVE VOLTAGE LINE - - - - - NEGATIVE VOLTAGE LINE

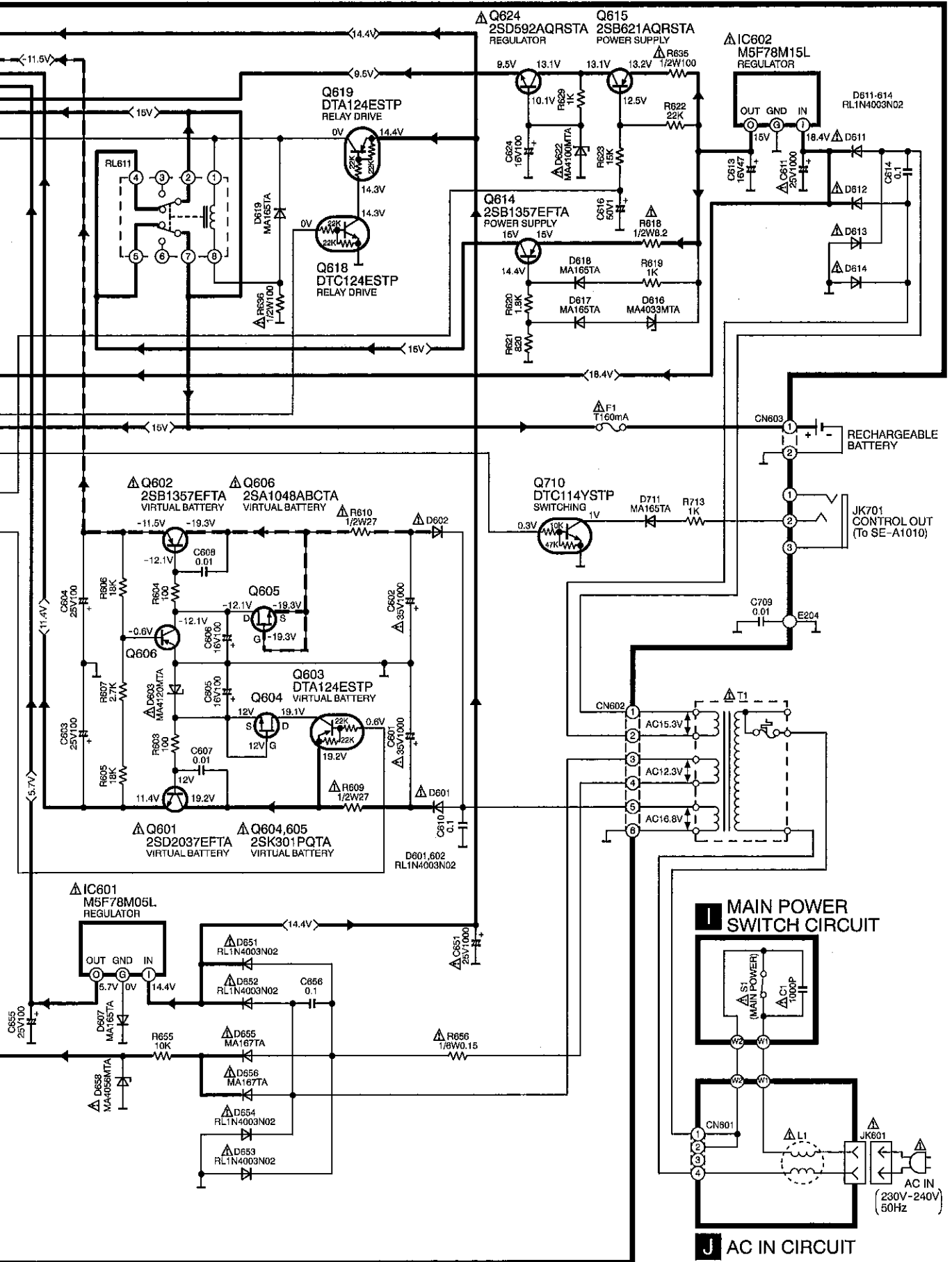

8 Printed Circuit Board Diagram

This printed circuit board diagram may be modified at any time with the development of new technology.

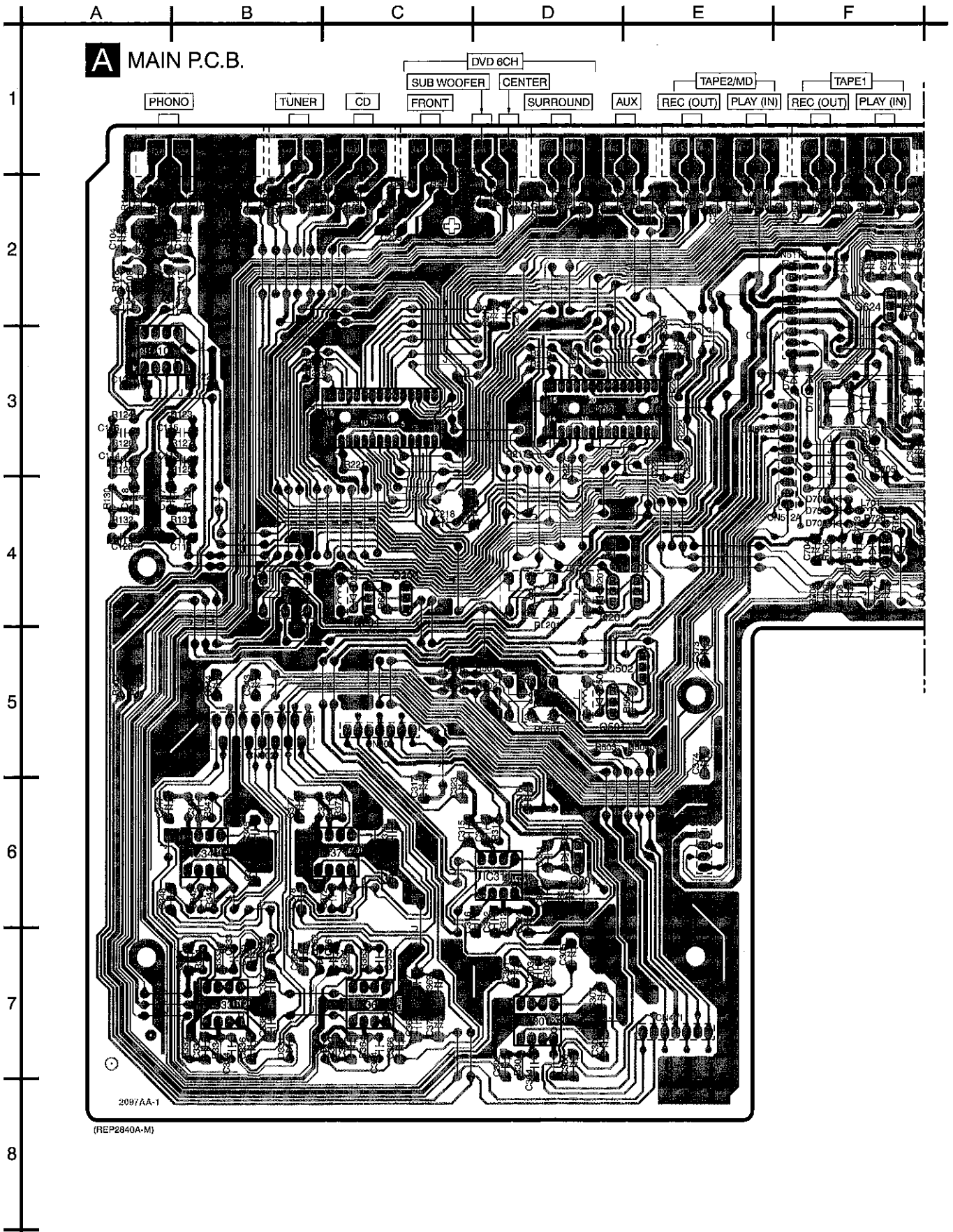

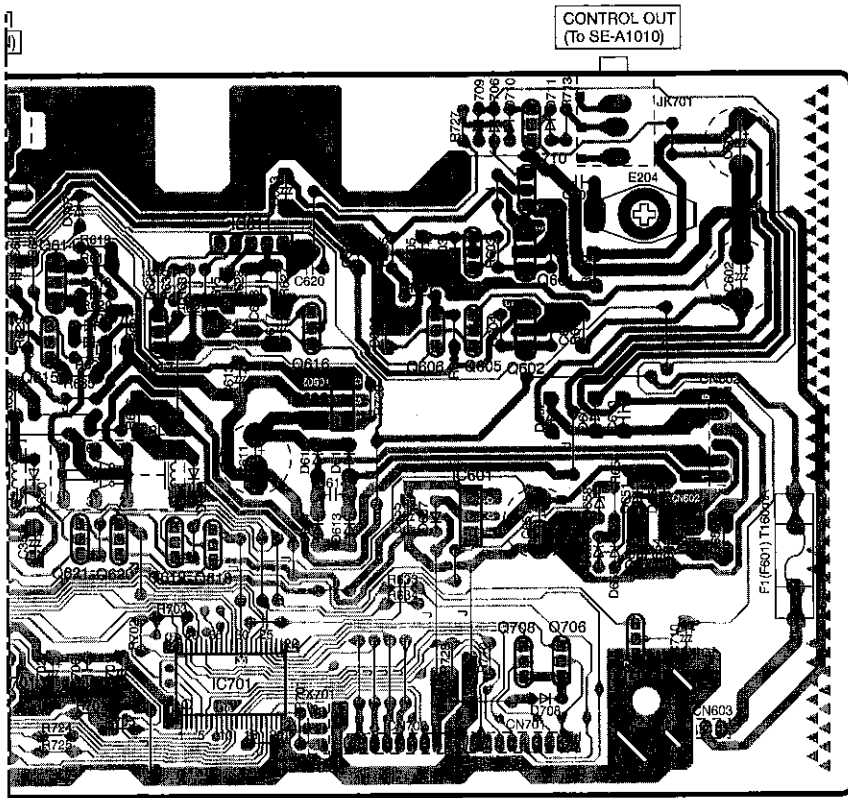
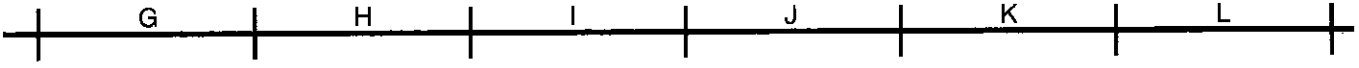

■ ELECTRICAL PARTS LOCATION

Ref. No.	Lo. No.	Ref. No.	Lo. No.	Ref. No.	Lo. No.	Ref. No.	Lo. No.	Ref. No.	Lo. No.	Ref. No.	Lo. No.	Ref. No.	Lo. No.	Ref. No.	Lo. No.	Ref. No.	Lo. No.	Ref. No.	Lo. No.
A MAIN P.C.B.																			
IC101	3A	Q706	4I	D706	1I	JK206	1F	R219	3B	R503	5D	R705	4G	C207	2D	C318	6D	C375	6C
IC201	3C	Q708	4I	D707	2G	JK701	1I	R220	3B	R504	5E	R706	4F	C208	2D	C319	6D	C376	6C
IC202	3D	Q710	1I	D708	4I	E203	2C	R221	3C	R505	5E	R707	4G	C209	2D	C320	6D	C377	6B
IC301	7D	D201	4D	D709	1I	E204	2I	R222	3E	R603	2I	R708	4F	C210	2D	C321	6D	C378	6B
IC311	6D	D202	4C	D710	1I	R101	2B	R223	3E	R604	2I	R709	4F	C211	2E	C323	6C	C601	2J
IC331	7B	D301	6D	D711	1I	R102	2A	R224	3D	R605	2H	R710	4I	C212	2D	C324	6D	C602	2J
IC341	6B	D331	7B	D712	4F	R103	2B	R227	3D	R606	2I	R713	1I	C215	3D	C331	7B	C603	2H
IC361	7C	D332	7B	D714	3F	R104	2A	R251	2E	R607	2H	R724	4G	C217	2D	C332	7B	C604	2H
IC371	6C	D361	7C	D715	3F	R105	2A	R252	2E	R609	2I	R725	4G	C218	4C	C333	7B	C605	2H
IC601	3I	D362	7B	D716	2F	R106	2A	R253	2E	R610	2I	R726	4F	C219	2D	C334	7B	C606	2H
IC602	3H	D501	5D	L701	4F	R117	2B	R254	2E	R618	2G	R727	1I	C220	4D	C335	7B	C607	2I
IC611	2H	D601	3I	X701	4H	R118	2A	R255	2F	R619	2G	R728	4I	C221	3C	C336	7B	C608	2I
IC701	4G	D602	3I	F1(F601)	3J	R123	3B	R256	2F	R620	2G	R729	3H	C223	3E	C337	7B	C610	3I
Q201	4D	D603	2I	F611	4J	H124	3A	R257	2F	R621	2G	C101	2B	C224	3E	C338	7B	C611	3H
Q202	4E	D607	3H	F612	3J	R125	3B	R258	2F	R622	2G	C102	2A	C225	3E	C341	6B	C613	3H
Q203	4C	D611	3H	RL201	4D	R126	3A	R301	5A	R623	2G	C103	2B	C226	3E	C342	6B	C614	3H
Q204	4C	D612	3H	RL202	4B	R127	3B	R302	5A	R624	2G	C104	2A	C251	2E	C343	5B	C615	2H
Q301	6D	D613	3H	RL501	5D	R128	3A	R303	7D	R625	2G	C107	2A	C252	2E	C344	5B	C616	2F
Q501	5D	D614	3H	RL611	3G	R129	4B	R304	7D	R626	2G	C108	2A	C253	2F	C345	6B	C617	2H
Q502	5E	D616	2G	RL612	3F	R130	4A	R311	6D	R627	2H	C113	3B	C254	2E	C346	6B	C618	2H
Q601	2I	D617	2G	CN301	5C	R131	4B	R312	6D	R628	2H	C114	3A	C255	2F	C347	6A	C620	2H
Q602	2I	D618	2G	CN302	5B	R132	4A	R315	5C	R629	2F	C115	3B	C256	2F	C348	6A	C624	2F
Q603	2I	D619	3G	CN303	6E	R201	2B	R316	5C	R630	2G	C116	3A	C257	2G	C351	3G	C651	3I
Q604	2I	D620	3G	CN401	7E	R202	2B	R331	7B	R631	2G	C117	4A	C258	2F	C361	7C	C655	3H
Q605	2I	D622	2F	CN511A	3F	R203	2C	R332	7B	R633	4H	C118	4A	C301	7D	C362	7C	C656	3J
Q606	2H	D651	3I	CN511B	2F	R204	2C	R333	7B	R634	4H	C119	4B	C302	7D	C363	7C	C701	4G
Q614	2G	D652	3J	CN512A	4F	R205	2C	R334	7B	R635	3G	C120	4A	C303	7D	C364	7C	C702	4G
Q615	2G	D653	3I	CN512B	3F	R206	2C	R341	6B	R636	3G	C121	3A	C304	7D	C365	7B	C703	4F
Q616	2H	D654	3J	CN602	3J	R207	2D	R342	6B	R637	3F	C122	3B	C305	7D	C366	7C	C704	4F
Q617	2G	D655	3I	CN603	4J	R208	2D	R361	7C	R639	4D	C123	2B	C306	7D	C367	7C	C705	4F
Q618	3G	D656	3I	CN701	4I	R209	2D	R362	7C	R640	4C	C124	2A	C307	7D	C368	7C	C706	4G
Q619	3G	D658	3I	CN702	4H	R210	2D	R363	7C	R655	3I	C201	2B	C308	7D	C369	7C	C707	4F
Q620	3G	D701	4F	JK201	1B	R211	2E	R364	7C	R656	3J	C202	2B	C311	6D	C370	7C	C708	4F
Q621	3G	D702	4F	JK202	1C	R212	2D	R371	6C	R701	4H	C203	2C	C312	6D	C371	6C	C709	2I
Q624	2F	D703	3F	JK203	1C	R215	3D	R372	6C	R702	4G	C204	2B	C315	6C	C372	6C	C710	4J
Q701	4F	D704	4F	JK204	1D	R216	3D	R501	5D	R703	4G	C205	2C	C316	6C	C373	5E		
Q702	4I	D705	3F	JK205	1E	R217	3D	R502	5D	R704	4F	C206	2C	C317	6C	C374	5E		

A B C D E F

B PRE OUT P.C.B.

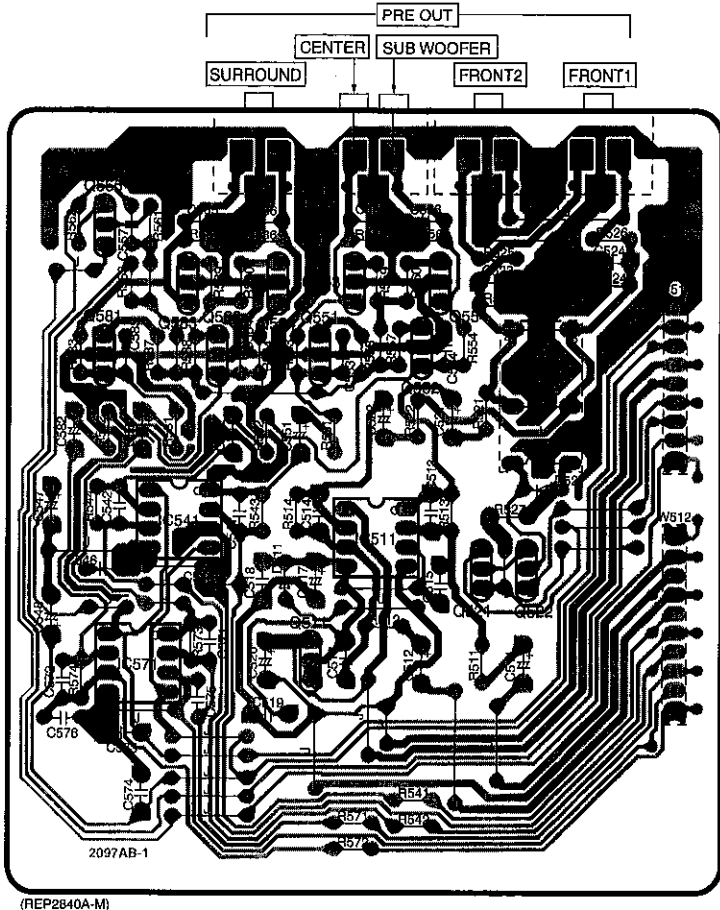

ELECTRICAL PARTS LOCATION

Ref. No.	Lo. No.	Ref. No.	Lo. No.
B PRE OUT P.C.B.			
IC511	3C	R573	4B
IC541	3B	R574	4A
IC571	4B	R581	3B
Q511	4C	R582	3B
Q521	4C	R583	3A
Q522	4C	R584	3B
Q551	3C	R585	2B
Q552	3C	R586	2B
Q553	2C	R587	3B
Q554	2C	R588	3B
Q555	2B	R589	2B
Q581	3B	R590	2B
Q582	3B	C511	4C
Q583	2B	C512	4C
Q584	2B	C513	3C
D511	4B	C514	3C
D521	3D	C515	4C
RL521	3D	C516	4C
JK501	2D	C517	4C
JK502	2C	C518	4B
W511	3D	C519	4B
W512	4D	C620	4B
R511	4C	C521	3C
R512	4C	C522	3C
R513	3C	C523	2C
R514	3B	C524	2D
R521	3C	C541	3B
R522	3C	C542	3B
R523	2C	C545	4B
R524	2D	C546	4B
R525	2C	C547	3A
R526	2D	C548	4A
R527	3C	C551	3B
R541	5C	C552	3B
R542	5C	C553	3C
R543	3B	C554	3C
R544	3B	C555	2C
R551	3C	C556	2C
R552	3B	C557	2B
R553	3B	C571	4B
R554	3C	C572	4A
R555	2C	C573	4B
R556	2C	C574	5B
R557	3C	C575	4B
R558	3C	C576	4A
R559	2C	C581	3B
R560	2C	C582	3A
R561	2B	C583	3B
R562	2A	C584	3B
R563	2B	C585	2B
R571	5C	C586	2B
R572	5C		
D VOLUME P.C.B.			
IC391	8C	R351	6B
VR301	7B	R352	6B
VR321	7D	R353	6B
VR322	7D	R354	6B
L391	7C	R381	6D
L392	8C	R382	7D
W301	7E	R383	6C
W302	6E	R384	6C
W303	8D	R391	8D
R321	7D	C391	8D
R322	7D	C392	8C
R323	7D	C393	8B
R324	7D	C394	7B

D VOLUME P.C.B.

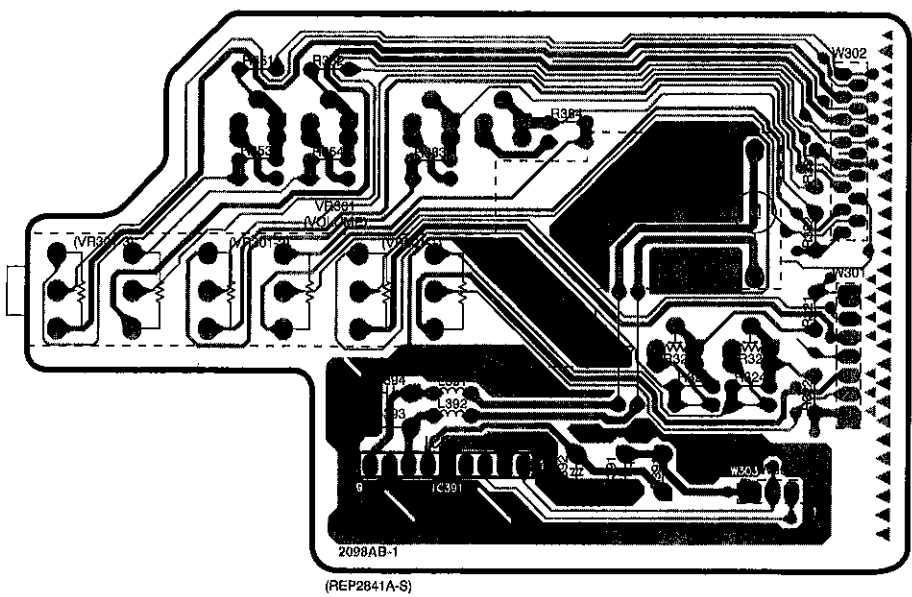

E OPERATION (1) P.C.B.

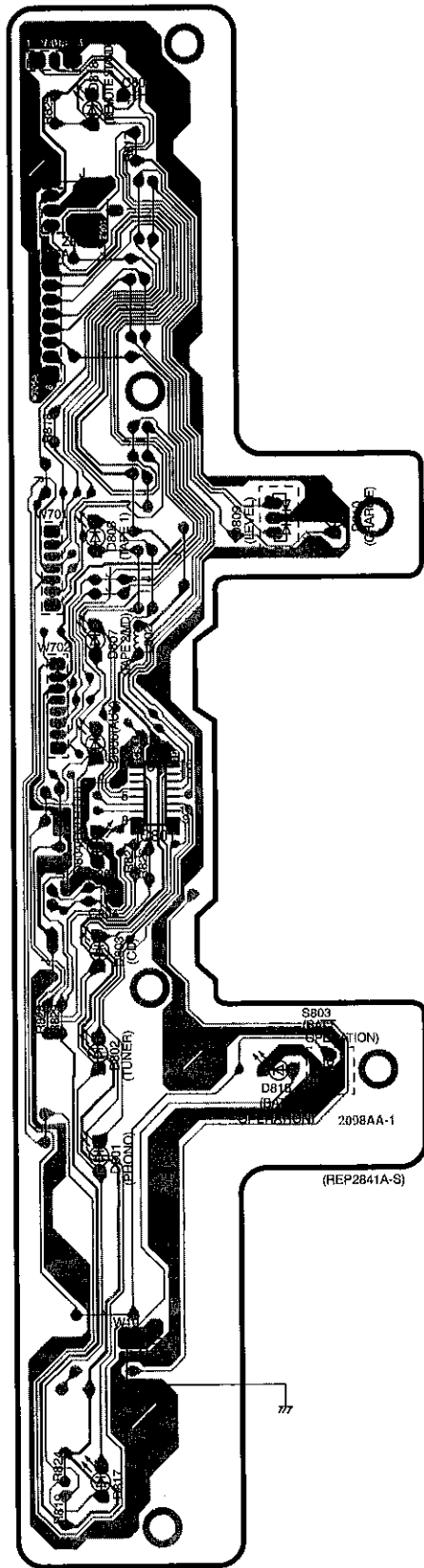

C TONE P.C.B.

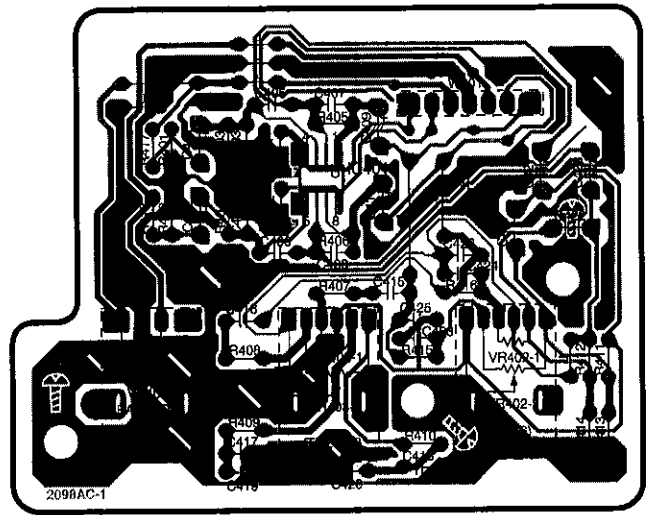

(REP2841A-S)

G POWER SWITCH P.C.B.

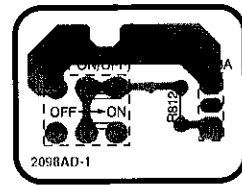

(REP2841A-S)

H SELECTOR P.C.B.

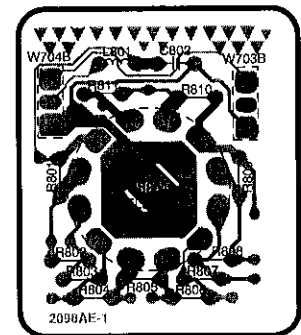

(REP2841A-S)

ELECTRICAL PARTS LOCATION

Ref. No.	Lo. No.	Ref. No.	Lo. No.	Ref. No.	Lo. No.	Ref. No.	Lo. No.	Ref. No.	Lo. No.
OPERATION (1) P.C.B.									
IC801	5B	D808	4A	Z801	2A	R818	3A	R829	6A
D801	7A	D809	3B	S803	6B	R819	9A	C801	1A
D802	6A	D810	3B	W701	4A	R824	8A	C803	5B
D803	6A	D816	6B	W702	4A	R825	2A	C804	5A
D804	5A	D817	8A	W704A	1A	R826	5B	C805	5A
D806	5A	D818	2A	W705A	2A	R827	5A		
D807	4A	L802	4A	R817	2A	R828	6A		
TONE P.C.B.									
IC401	2E	R406	2E	R416	2E	C408	2E	C420	3E
VR401	3D	R407	2E	R417	2D	C409	2E	C421	2F
VR402	3F	R408	3D	R418	2D	C410	2E	C422	2F
VR403	3E	R409	3D	C401	2D	C411	2E	C423	2E
W401	1E	R410	3E	C402	2D	C412	2E	C424	2E
R401	2D	R411	3F	C403	2D	C415	2E	C425	2E
R402	2D	R412	3F	C404	2D	C416	2D	C426	2E
R403	2D	R413	3F	C405	1E	C417	3D	C427	2F
R404	2D	R414	3F	C406	2E	C418	3E	C428	2F
R405	2E	R415	3E	C407	1E	C419	3D		
POWER SWITCH P.C.B.									
S805	4D	W703A	4D	R812	4D				
SELECTOR P.C.B.									
L801	4E	R801	5E	R805	5E	R809	5F		
S804	5E	R802	5E	R806	5F	R810	4F		
W703B	4F	R803	5E	R807	5F	R811	4E		
W704B	4E	R804	5E	R808	5F	C802	4F		

A B C D E F

1
2
3
4
5
6
7
8

F OPERATION (2) P.C.B.

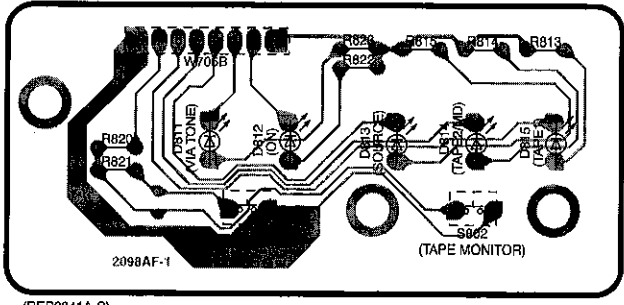

(REP2841A-S)

I MAIN POWER SWITCH P.C.B.

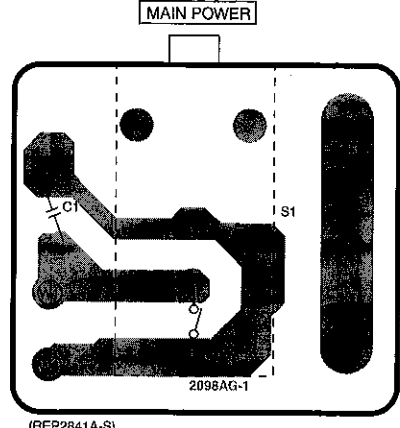

(REP2841A-S)

J AC IN P.C.B.

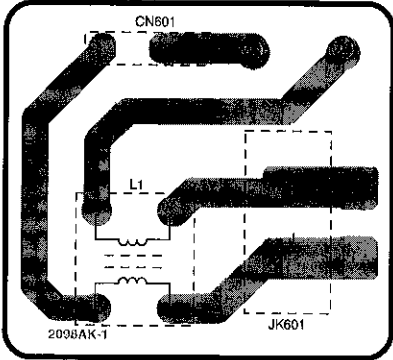

(REP2841A-S)



(230-240V, 50Hz)

AC IN

ELECTRICAL PARTS LOCATION

Ref. No.	Lo. No.	Ref. No.	Lo. No.	Ref. No.	Lo. No.	Ref. No.	Lo. No.
F OPERATION (2) P.C.B.							
D811	2B	D815	2C	R813	2C	R821	2A
D812	2B	S801	2B	R814	2C	R822	2B
D813	2C	S802	2C	R815	2C	R823	2B
D814	2C	W705B	2B	R820	2A		
I MAIN POWER SW P.C.B.							
S1	2E	W1	3E	W2	3E	C1	2E
J AC IN P.C.B.							
L1	5C	JK601	5D	W1	4D	W2	4D
CN601	4C						

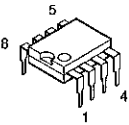
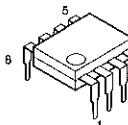
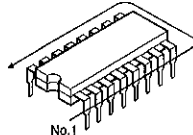
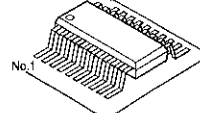
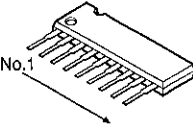
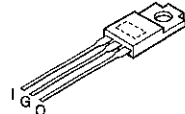
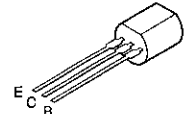
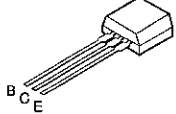
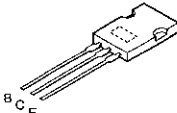
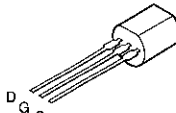
9 Type Illustration of ICs, Transistors and Diodes

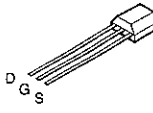
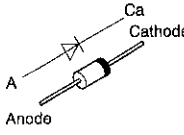
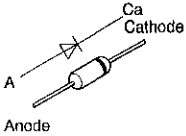
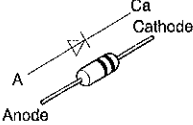
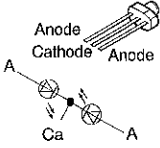
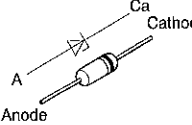
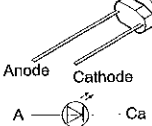
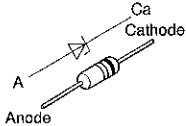
<p>UPC4570C AN6558F</p> 	<p>NJM4580DD</p> 	<table border="1" data-bbox="798 134 1021 201"> <tr> <td>TC9163N</td> <td>28PIN</td> </tr> <tr> <td>TC9164N</td> <td>28PIN</td> </tr> </table> 	TC9163N	28PIN	TC9164N	28PIN	<table border="1" data-bbox="1244 134 1468 224"> <tr> <td>NJM4580EDTE1</td> <td>8PIN</td> </tr> <tr> <td>BU2090AFE2</td> <td>16PIN</td> </tr> <tr> <td>M38503M2404F</td> <td>42PIN</td> </tr> </table> 	NJM4580EDTE1	8PIN	BU2090AFE2	16PIN	M38503M2404F	42PIN
TC9163N	28PIN												
TC9164N	28PIN												
NJM4580EDTE1	8PIN												
BU2090AFE2	16PIN												
M38503M2404F	42PIN												
 <table border="1" data-bbox="375 369 566 436"> <tr> <td>BA6218</td> <td>9PIN</td> </tr> <tr> <td>PST623XS</td> <td>5PIN</td> </tr> </table>	BA6218	9PIN	PST623XS	5PIN	<p>M5F78M05L M5F78M15L</p> 	<p>2SA933QRSTA 2SB621AQRSTA 2SD592AQRSTA</p> 	 <p>DTA114YSTP DTC114ESTP DTC114YSTP DTA124ESTP DTC124ESTP DTC144ESTP 2SA1048ABCTA</p>						
BA6218	9PIN												
PST623XS	5PIN												
<p>2SB1357EFTA 2SD2037EFTA</p> 	<p>2SK301PQTA</p> 	<p>2SD1915FTA</p> 	<p>2SK330GRYTA</p> 	<p>RL1N4003N02</p> 	<p>MA165TA MA167TA MA700ATA</p> 								
<p>1SS291TA</p> 	<p>SPR505MDTT</p> 	<p>MA4100MTA MA4120MTA</p> 	<p>SLR325DCT31 SLR325VCT31</p> 	<p>MA4033MTA MA4047MTA MA4056MTA</p> 									

10 Block Diagram

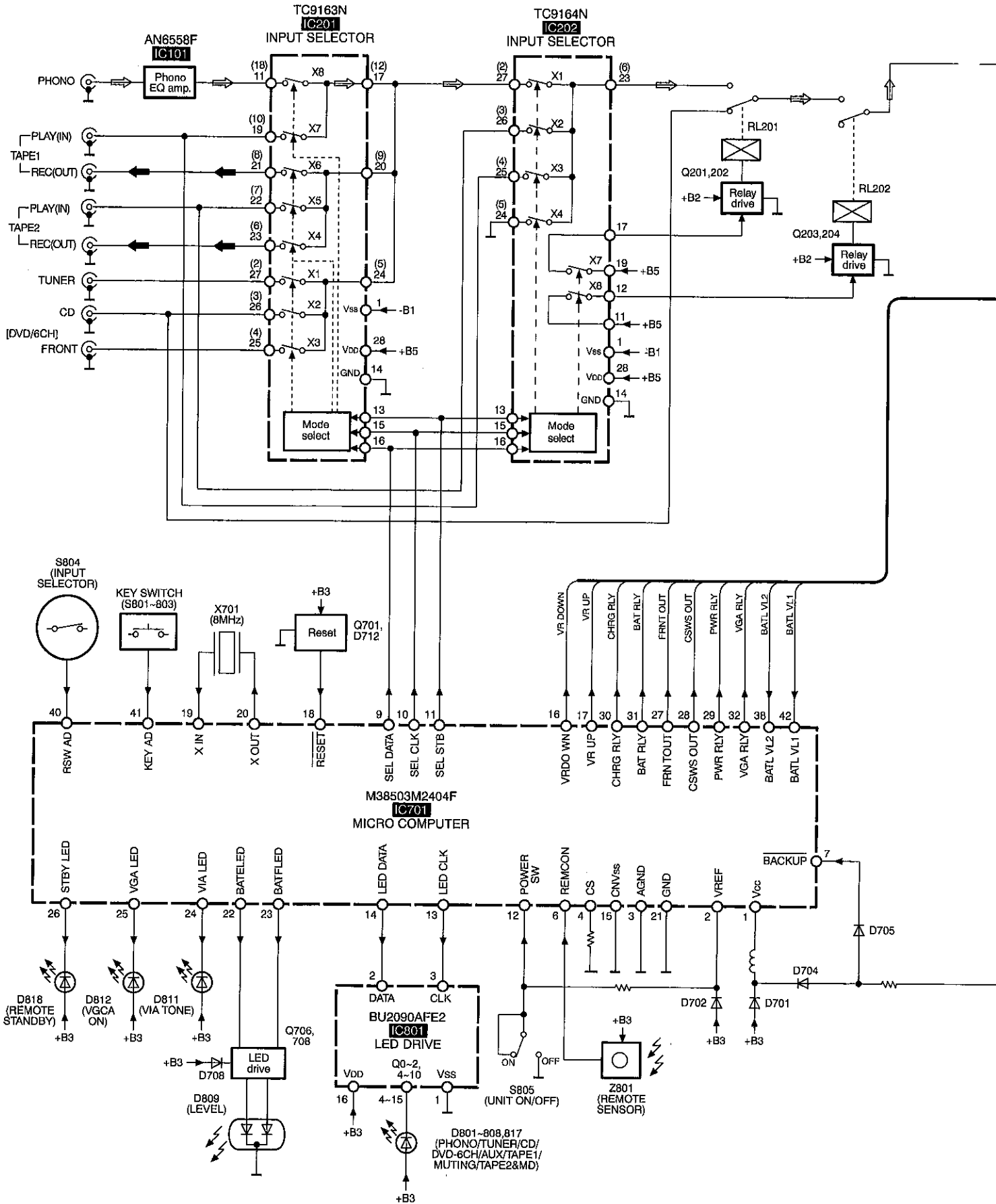

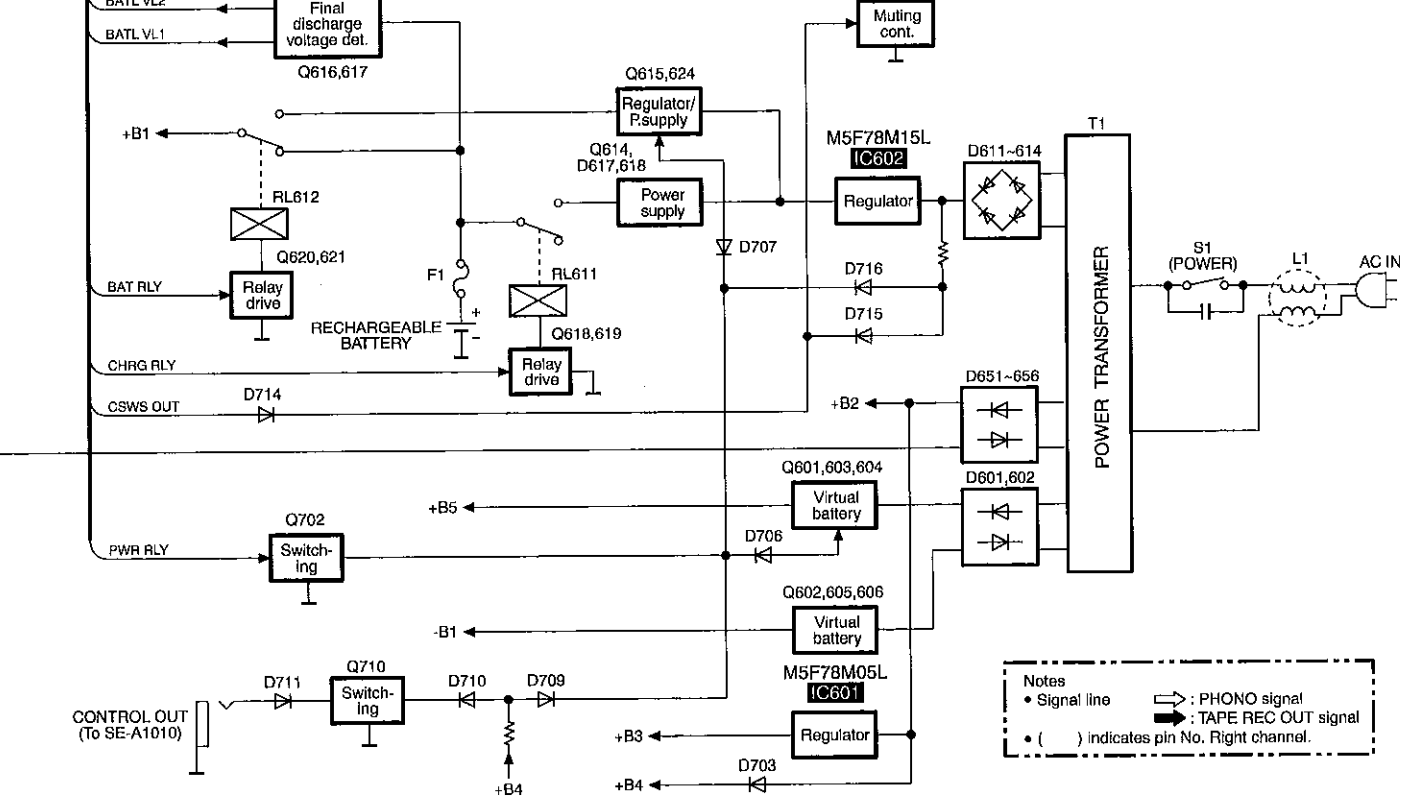
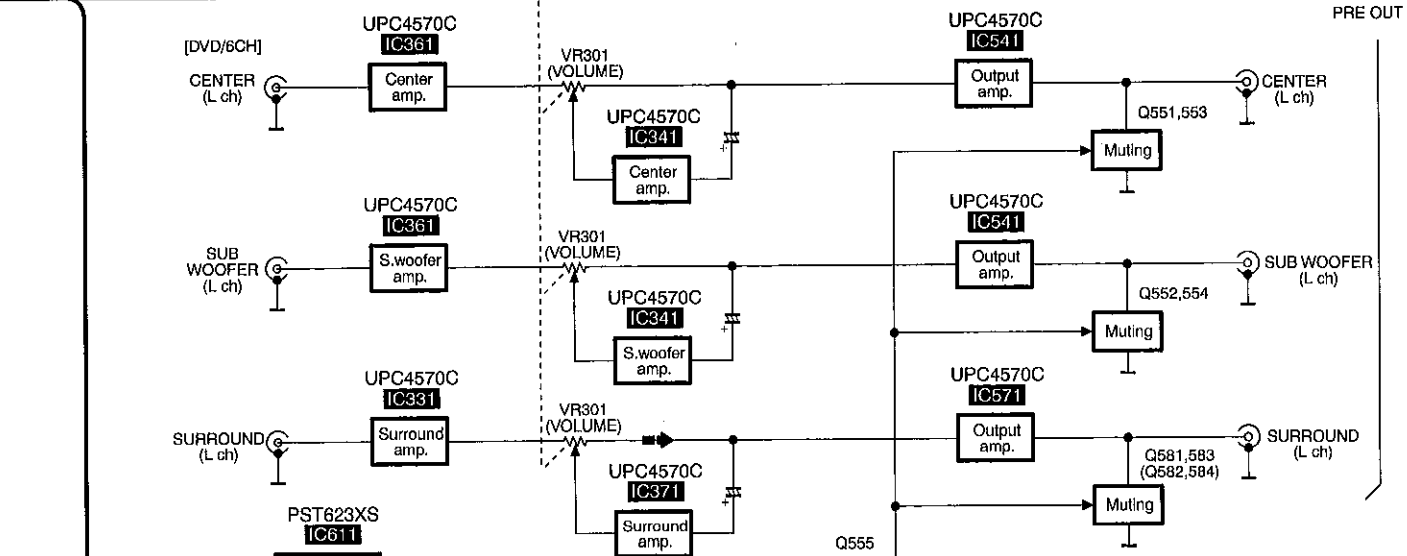
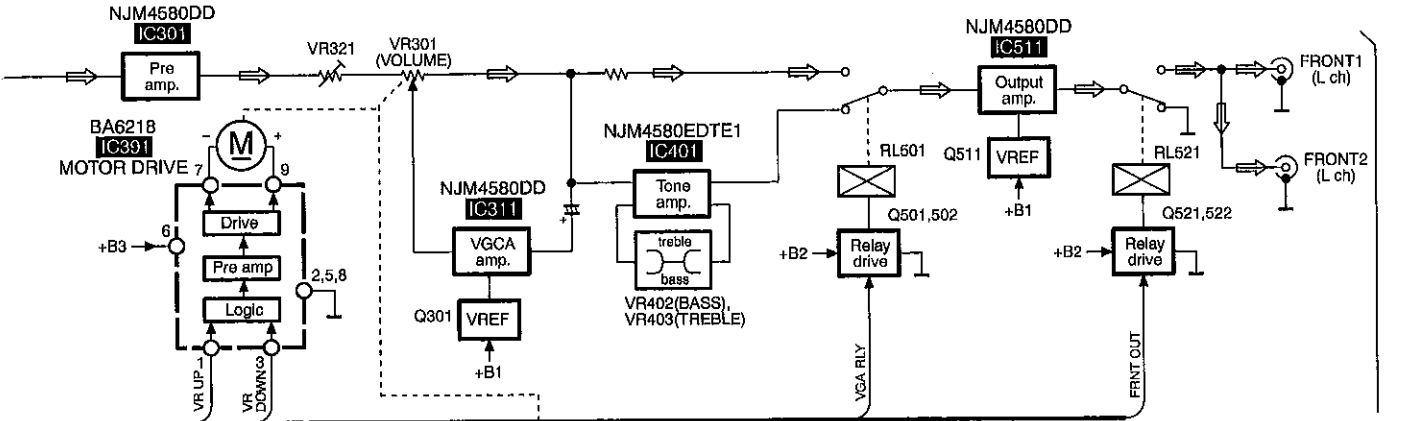

- Notes
- Signal line
 - ◀ : PHONO signal
 - ▶ : TAPE REC OUT signal
 - () indicates pin No. Right channel.

11 Wiring Connection Diagram

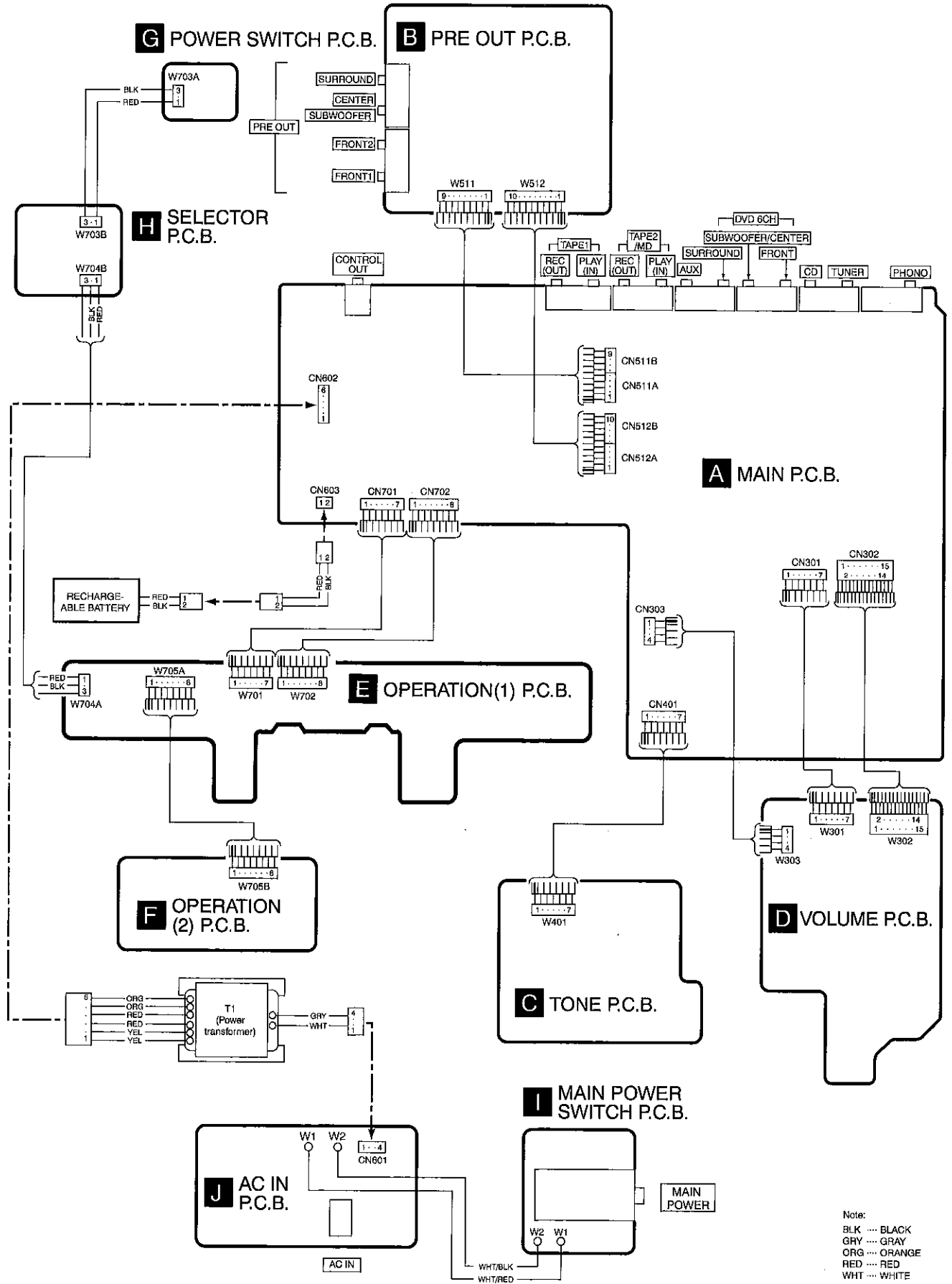

Note:
 BLK BLACK
 GRY GRAY
 ORG ORANGE
 RED RED
 WHT WHITE

12 Measurement and Adjustment

12.1. Measurement instruments and Special tools

• AC electric voltmeter (AC EVM)

• AF oscillator

12.2. Output voltage Adjustment

1. Turn on the power after the MAIN POWER turned on.
2. Select the input source to CD.
3. Connect the measuring instrument as shown in Fig.1.
4. Apply 1 kHz, 200 mV signal to CD terminal.

5. Adjust the VOLUME to maximum.

6. Adjust **VR321** (L ch) and **VR322** (R ch) so that the output voltage to AC 1.00 V \pm 0.2 dB.

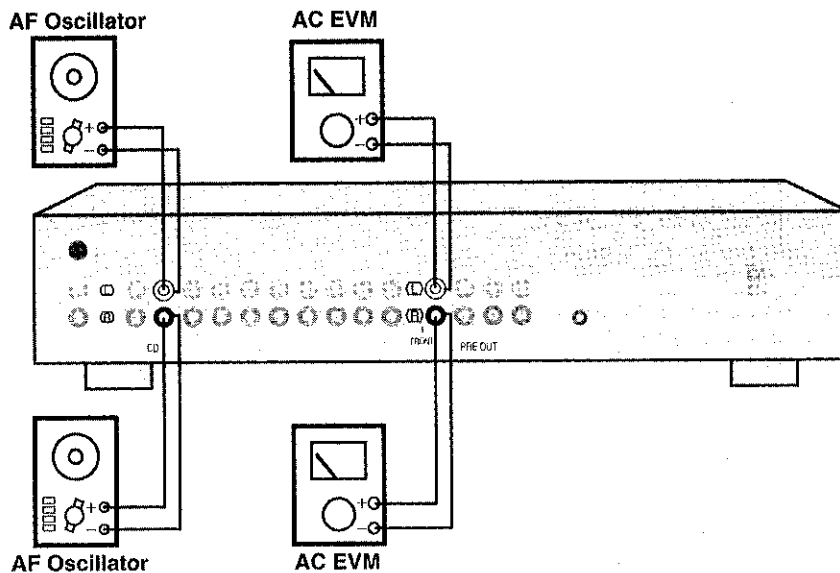
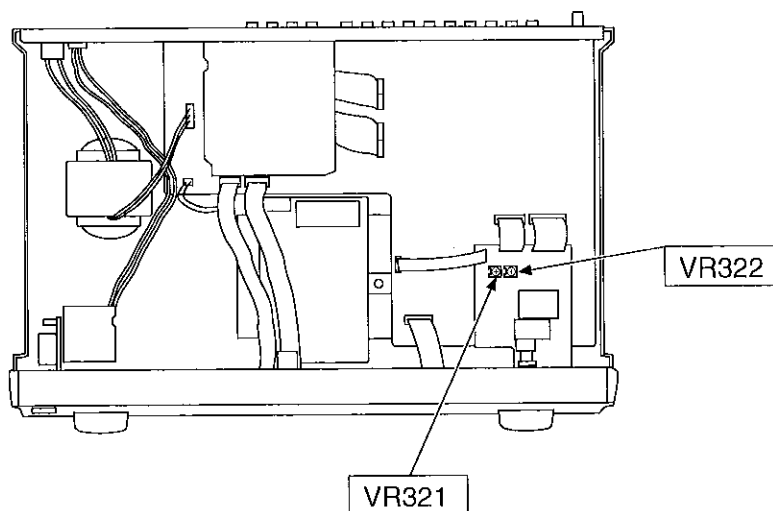

Fig.1.

• Adjustment Point



13 Terminal Function of ICs

13.1. IC701 (M38503M2404F) : Micro Computer

Pin No.	Name	I/O	Function
1	V _{CC}	I	Power supply (+5 V) terminal
2	VREF	I	Reference voltage input
3	AV _{SS}	-	GND terminal
4	CS	I	Chip select signal input
5	NC	-	Not used, open
6	REMOCON	I	Remote control signal input
7	BACKUP	I	Power failure detect signal input
8	NC	-	Not used, open
9	SELDATA	O	Data signal output for input select IC (IC201 and IC202)
10	SELCLK	O	Clock signal output for input select IC (IC201 and IC202)
11	SELSTB	O	Strobe signal output for input select IC (IC201 and IC202)
12	POWER SW	I	Power switch (S805) detect signal input
13	LEDCLK	O	Clock signal output for LED drive IC
14	LEDDATA	O	Data signal output for LED drive IC
15	CNV _{SS}	-	Connected to GND
16	VRDOWN	O	Motor drive signal output (Volume down)
17	VRUP	O	Motor drive signal output (Volume up)
18	RESET	I	System reset signal input
19	XIN	I	Connected to the ceramic oscillator (8 MHz)
20	XOUT	O	Connected to the ceramic oscillator (8 MHz)
21	V _{SS}	-	GND terminal
22	BATELED	O	Battery level (empty) LED (D809) drive signal output
23	BATFLED	O	Battery level (full) LED (D809) drive signal output
24	VIALED	O	VIA LED drive signal output
25	VGCALED	O	VGCA LED drive signal output
26	STBYLED	O	Stand by LED drive signal output
27	FRNTOUT	O	Front output control signal output
28	CSWSOUT	O	Center/S.woofer/Surround output control signal output
29	PWRRLY	O	Power control signal output
30	CHRGRLY	O	Battery charge relay control signal output
31	BATRLY	O	Battery drive relay control signal output
32	VGCARLY	O	VGCA mode relay control signal output
33 36	NC	-	Not used, open
37	SELPH	O	
38	BATLVL2	I	Battery voltage detection (2) signal input
39	NC	-	Not used, open
40	RSWAD	I	Input selector switch (S804)
41	KEYAD	I	Tape monitor and VGCA switch input
42	BATLVL1	I	Battery voltage detection (1) signal input

14 Replacement Parts List

Notes:

- Important safety notice:

Components identified by Δ mark have special characteristics important for safety.

Furthermore, special parts which have purposes of fire-retardant (resistors), high-quality sound (capacitors), low-noise (resistors), etc. are used.

When replacing any of components, be sure to use only manufactures specified parts shown in the parts list.

- The mark in Remarks indicates as follow.

– Language of instruction manual.

<IA> : English, Spanish, Swedish, Russian, Polish, Czech

<IB> : English

<IC> : German, Italian, French

<ID> : Netherlandish, Danish

– Specify the colours

<K> : For Black Type.

<N> : For Gold Type

- The parenthesized indications in the Remarks columns specify the areas. (Refer to the cover page for area.)
- The marking (RTL) indicates that Retention Time is Limited for this item. After the discontinuation of this assembly in production, the item will continue to be available for a specific period of time. The retention period of availability is dependent on the type of assembly, and in accordance with the laws governing part and product retention. After the end of this period, the assembly will no longer be available.
- All parts are supplied by MESA.

Ref. No.	Part No.	Part Name & Description	Pcs.	Remarks
1	RKM007B-1K	TOP CABINET	1	<K>
1	RKM007B-N	TOP CABINET	1	<N>
2	RHD30035-K1	SCREW	4	<K>
2	SNE2129	SCREW	4	<N>
3	XTBS3+8JFZ1	SCREW	2	
4	REX0758	WIRE ASS'Y	1	
5	RGK1162-K	TRAY ORNAMENT	1	<K>
5	RGK1162-N	TRAY ORNAMENT	1	<N>
6	RGQ0179B-K	BATTERY TRAY	1	
7	RGW0229-K	KNOB, SELECTOR	1	<K>
7	RGW0229-N	KNOB, SELECTOR	1	<N>
8	RGW0230-K	KNOB, VOLUME	1	<K>
8	RGW0230-N	KNOB, VOLUME	1	<N>
9	RHD26016	SCREW	1	
10	RKA0053-A	FOOT	4	
10-1	RMG0270-K	RUBBER	4	
11	RME0190	SPRING	1	
12	RMR0904-K	BATTERY BASE	1	
13	RMR0905-K	LEVER	1	
14	RMR0910-K	ARM	1	
15	RMR0911-K	BATTERY COVER	1	
16	RDG0449	GEAR	2	
17	RGB0031-A	TECHNICS BADGE	1	
18	RGB0112-N	VGCA BADGE	1	
19	GGG0168-K	PANEL	1	<K>
19	GGG0168-N	PANEL	1	<N>
20	RGK0747-S	RING ORNAMENT	1	<K>
20	RGK0747-N	RING ORNAMENT	2	<N>

Ref. No.	Part No.	Part Name & Description	Pcs.	Remarks
21	RGK1111-K	NUT	4	
22	RGK1163-K	DISPLAY 1	1	<K>
22	RGK1163-N	DISPLAY 1	1	<N>
23	RGK1164-K1	DISPLAY 2	1	<K>
23	RGK1164-N1	DISPLAY 2	1	<N>
24	RGL0453-Q	PANEL LIGHT 1	2	
25	RGL0454-Q	PANEL LIGHT 2	3	
26	RGF0740-K	SUB GRILL	1	<K>
26	RGF0740-N	SUB GRILL	1	<N>
27	RGF0743-K	GRILL	1	<K>
27	RGF0743-N	GRILL	1	<N>
28	RGU0890-1K	BUTTON, POWER	1	<K>
28	RGU0890-1N	BUTTON, POWER	1	<N>
29	RGU1207-S	BUTTON, MAIN POWER	1	<K>
29	RGU1207-1N	BUTTON, MAIN POWER	1	<N>
30	RGU1712-K	BUTTON, OPEN	1	<K>
30	RGU1712-N	BUTTON, OPEN	1	<N>
31	RGU1774-S	BUTTON, VGCA	1	<K>
31	RGU1774-N	BUTTON, VGCA	1	<N>
32	RGW0205-S	KNOB, BALANCE	3	<K>
32	RGW0205-N	KNOB, BALANCE	3	<N>
33	RHD26033	SCREW	4	
34	RHD26034	SCREW	3	
35	RHN90001	NUT	2	
36	RKF0593-Q	DOOR	1	<K>
36	RKF0593-2Q	DOOR	1	<N>
37	RKG0009	MAGNET	1	
38	RKW0273A-K	WINDOW	1	<K>
38	RKW0273-N	WINDOW	1	<N>
39	RME0284	SPRING	1	
40	RMR1202-K	ARM(L)	1	<K>
40	RMR1202-H	ARM(L)	1	<N>
41	RMR1203-K	ARM(R)	1	<K>
41	RMR1203-H	ARM(R)	1	<N>
42	RMR1204-K	MAGNET HOLDER	1	
43	RMR1205-K	DAMPER HOLDER	2	
44	RMR1206-K	DAMPER (R)	1	<K>
44	RMR1206-H	DAMPER (R)	1	<N>
45	RMR1207-K	DAMPER (L)	1	<K>
45	RMR1207-H	DAMPER (L)	1	<N>
46	XTBS26+8J	SCREW	26	
47	XTS2+4GEZ	SCREW	4	
48	SJS9231A	AC INLET COVER	1	
49	SNE2123	SCREW	1	
50	XTBS3+8JFZ1	SCREW	11	
51	XTB3+12JFZ	SCREW	2	
52	XTB3+20JFZ	SCREW	7	
53	XTB3+6JFZ	SCREW	7	
55	XTB3+8JFZ	SCREW	3	
A1	P-06RM/8A13	BATTERY PACK	1	
A2	RAK-SUA11WH	REMOTE CONT. TRANSMITTER	1	
A2-1	RKK0123-K	BATTERY COVER	1	
A3	RJA0019-X	AC POWER SUPPLY CORD	1	(E, EG)
Δ				
A3	RJA0053-2X	AC POWER SUPPLY CORD	1	(EB)
Δ				
A4	SJP2276	PIN CORD	1	
A5	RQCB0169	SERVICE CENTER LIST	1	
A6	RQA0117	WARRANTY CARD	1	
A7	RQT5007-E	OPERATING INSTRUCTIONS	1	(E) <IA>
A8	RQT5010-B	OPERATING INSTRUCTIONS	1	(EB) <IB>
A9	RQT5008-D	OPERATING INSTRUCTIONS	1	(EG) <IC>
A10	RQT5009-H	OPERATING INSTRUCTIONS	1	(EG) <ID>
C1	Δ ECKWRS102MBC	125V 1000P	1	

Ref. No.	Part No.	Part Name & Description	Pcs.	Remarks
C101,02	ECBT1H221KB5	50V 220P	2	
C103,04	ECA1HPXS4R7B	50V 4.7U	2	
C107,08	RCE1AKA330BG	10V 33U	2	
C113,14	ECQB1H682JF3	50V 6800P	2	
C115,16	ECQB1H223JF3	50V 0.022U	2	
C117,18	ECEA1VKA4R7B	35V 4.7U	2	
C119,20	ECQB1H472JF3	50V 4700P	2	
C121,22	ECKR1H103ZF5	50V 0.01U	2	
C123,24	ECBT1H102KB5	50V 1000P	2	
C201,02	ECBT1H101KB5	50V 100P	2	
C203-06	ECCR1H101K5	50V 100P	4	
C207-12	ECBT1H101KB5	50V 100P	6	
C215	ECBT1H101KB5	50V 100P	1	
C217,18	ECBT1C103NS5	16V 0.01U	2	
C219,20	ECA1HPXS4R7B	50V 4.7U	2	
C221	ECBT1H101KB5	50V 100P	1	
C223,24	ECBT1C103NS5	16V 0.01U	2	
C225,26	ECA1HPXS4R7B	50V 4.7U	2	
C251-58	ECBT1H101KB5	50V 100P	8	
C301,02	ECA1EPXS100B	25V 10U	2	
C303,04	ECCR1H101J5	50V 100P	2	
C305,06	ECA1EPXS101B	25V 100U	2	
C307	ECA1HPXS100B	50V 10U	1	
C308	ECA1HPXS100B	50V 10U	1	
C311,12	ECCR1H560JC5	50V 56P	2	
C315,16	ECCR1H101J5	50V 100P	2	
C317,18	ECA1EPXS470B	25V 47U	2	
C319	ECA1CAM471XB	16V 470U	1	
C320,21	ECQB1H103JZ	50V 0.01U	2	
C323,24	ECA1EPXS101B	25V 100U	2	
C331,32	ECA1CAK100XB	16V 10U	2	
C333,34	ECBT1H101KB5	50V 100P	2	
C335,36	ECA1CAK101XB	16V 100U	2	
C337,38	ECKR1H103ZF5	50V 0.01U	2	
C341,42	ECBT1H560J5	50V 56P	2	
C343,44	ECA1CPXS101	16V 100U	2	
C345,46	ECKR1H103ZF5	50V 0.01U	2	
C347,48	ECA1CAK101XB	16V 100U	2	
C351	ECA1EPX101TB	25V 100U	1	
C361,62	ECA1CAK100XB	16V 10U	2	

Ref. No.	Part No.	Part Name & Description	Pcs.	Remarks
C363,64	ECBT1H101KB5	50V 100P	2	
C365,66	ECA1CAK101XB	16V 100U	2	
C367,68	ECKR1H103ZF5	50V 0.01U	2	
C369,70	ECA1CAK101XB	16V 100U	2	
C371,72	ECBT1H560J5	50V 56P	2	
C373,74	ECA1CPXS101	16V 100U	2	
C375,76	ECKR1H103ZF5	50V 0.01U	2	
C377,78	ECA1CAK101XB	16V 100U	2	
C391,92	ECEA0JKS101	6.3V 100U	2	
C393,94	ECQV1H104JM3	50V 0.1U	2	
C401,02	ECEA1HKS010	50V 1U	2	
C403-06	ECBT1H101KB5	50V 100P	4	
C407,08	ECBT1H560J5	50V 56P	2	
C409,10	RCE1CKA470BG	16V 47U	2	
C411,12	ECBT1E103ZF	25V 0.01U	2	
C415,16	ECBT1C222KR5	16V 2200P	2	
C417,18	ECBT0J153MS5	6.3V 0.015U	2	
C419,20	ECBT1C332KR5	16V 3300P	2	
C421,22	ECQV1H823JZ	50V 0.082U	2	
C423,24	ECBT0J153MS5	6.3V 0.015U	2	
C425,26	ECBT1H121KB5	50V 120P	2	
C427,28	ECEA1HKS010	50V 1U	2	
C511,12	ECA1CPXS101	16V 100U	2	
C513,14	ECCR1H331J5	50V 330P	2	
C515,16	ECCR1H101J5	50V 100P	2	
C517	ECA1CAM471XB	16V 470U	1	
C518,19	ECQB1H103JZ	50V 0.01U	2	
C520	ECA1EPXS100B	25V 10U	1	
C521,22	ECA1CPXS470B	16V 47U	2	
C523,24	ECCR1H331J5	50V 330P	2	
C541,42	ECBT1H331KB5	50V 330P	2	
C545,46	ECBT1H101KB5	50V 100P	2	
C547,48	ECA1CPXS100B	16V 10U	2	
C551,52	ECA1CPXS470B	16V 47U	2	
C553-56	ECBT1H331KB5	50V 330P	4	
C557	ECBT1E103ZF	25V 0.01U	1	
C571,72	ECBT1H331KB5	50V 330P	2	
C573,74	ECKR1H103ZF5	50V 0.01U	2	
C575,76	ECBT1H101KB5	50V 100P	2	
C581,82	ECA1CPXS470B	16V 47U	2	
C583-86	ECBT1H331KB5	50V 330P	4	

Ref. No.	Part No.	Part Name & Description	Pcs.	Remarks
C601,02	EEUPL1V102ZE	35V 1000U	2	
C603,04	ECA1EPXS101B	25V 100U	2	
C605,06	ECA1CPXS101	16V 100U	2	
C607,08	ECBT1C103NS5	16V 0.01U	2	
C610	ECQV1H104JM3	50V 0.1U	1	
C611	ECA1EPX102E	25V 1000U	1	
C613	ECA1CPXS470B	16V 47U	1	
C614	ECQV1H104JM3	50V 0.1U	1	
C615	ECQB1H103JZ	50V 0.1U	1	
C616,17	ECEA1HKS010	50V 1U	2	
C618	ECBT1E103ZF	25V 0.01U	1	
C620	ECBT1H104ZF5	50V 0.1U	1	
C624	ECA1CPXS101	16V 100U	1	
C651	ECA1EAM102XE	25V 1000U	1	
C655	ECA1EPX101TB	25V 100U	1	
C656	ECQV1H104JM3	50V 0.1U	1	
C701,02	ECA0JM102	6.3V 1000U	2	
C703	RCE1HKAR47BG	50V 0.47U	1	
C704	ECEA1HKS2R2	50V 2.2U	1	
C705,06	ECBT1C103NS5	16V 0.01U	2	
C707,08	RCE1HKAR22BG	50V 0.22U	2	
C709	ECBT1C103NS5	16V 0.01U	1	
C710	ECEA1VKA4R7B	35V 4.7U	1	
C801	ECEA0JKS101	6.3V 100U	1	
C802	ECBT1E103ZF	25V 0.01U	1	
C803	ECBT1H104ZF5	50V 0.1U	1	
C804,05	ECBT1H101KB5	50V 100P	2	
C806	ECBT1H104ZF5	50V 0.1U	1	
CN301	RJS1A6607T1	CONNECTOR (7P)	1	
CN302	RJS2A5515	CONNECTOR (15P)	1	
CN303	RJS1A6604	CONNECTOR (4P)	1	
CN401	RJS1A6607T1	CONNECTOR (7P)	1	
CN511A	RJS1A6605	CONNECTOR (5P)	1	
CN511B	RJS1A6604	CONNECTOR (4P)	1	
CN512A	RJS1A6605	CONNECTOR (5P)	1	
CN512B	RJS1A6605	CONNECTOR (5P)	1	
CN601	RJPLA4204-1	CONNECTOR (4P)	1	
CN602	SJT3611	CONNECTOR (6P)	1	
CN603	SJT3213	CONNECTOR (2P)	1	
CN701	RJS7T4ZA	CONNECTOR (7P)	1	
CN702	RJS8T4ZA	CONNECTOR (8P)	1	
D201,02	MA165	DIODE	2	
D301	MA4047M	DIODE	1	
D331,32	MA700	DIODE	2	
D361,62	MA700	DIODE	2	
D501	MA165	DIODE	1	
D511	MA4047M	DIODE	1	
D521	MA165	DIODE	1	

Ref. No.	Part No.	Part Name & Description	Pcs.	Remarks
D601,02	RL1N4003N02	DIODE	2	
D603	MA4120M	DIODE	1	
D607	MA165	DIODE	1	
D611-14	RL1N4003N02	DIODE	4	
D616	MA4033M	DIODE	1	
D617-20	MA165	DIODE	4	
D622	MA4100M	DIODE	1	
D651-54	RL1N4003N02	DIODE	4	
D655,56	MA167	DIODE	2	
D658	MA4056M	DIODE	1	
D701	1SS291TA	DIODE	1	
D702	MA165	DIODE	1	
D703	RL1N4003N02	DIODE	1	
D704	1SS291TA	DIODE	1	
D705-12	MA165	DIODE	8	
D714-16	MA165	DIODE	3	
D801-04	SLR325VCT31	LED	4	
D806-08	SLR325VCT31	LED	3	
D809	SPR505MDTT	LED	1	
D810	SLR325VCT31	LED	1	
D811	SLR325DCT31	LED	1	
D812,13	SLR325VCT31	LED	2	
D814,15	SLR325DCT31	LED	2	
D816-18	SLR325VCT31	LED	3	
F1	XBA2C016TB0S	FUSE	1	
IC101	AN6558F	IC	1	
IC201	TC9163N	IC	1	
IC202	TC9164N	IC	1	
IC301	NJM4580DD	IC	1	
IC311	NJM4580DD	IC	1	
IC331	UPC4570C	IC	1	
IC341	UPC4570C	IC	1	
IC361	UPC4570C	IC	1	
IC371	UPC4570C	IC	1	
IC391	BA6218	IC	1	
IC401	NJM4580EDTE1	IC	1	
IC511	NJM4580DD	IC	1	
IC541	UPC4570C	IC	1	
IC571	UPC4570C	IC	1	
IC601	M5F78M05L	IC	1	
IC602	M5F78M15L	IC	1	
IC611	FST623XS	IC	1	
IC701	M3B503M2404F	IC	1	
IC801	BU2090AFE2	IC	1	
JK201	SJF3069-11A	JACK	1	
JK202	SJF3069A	JACK	1	
JK203	SJF3069-21A	JACK	1	
JK204-06	SJF3069A	JACK	3	
JK501	SJF3069-14A	JACK	1	
JK502	SJF3069-22A	JACK	1	

Ref. No.	Part No.	Part Name & Description	Pcs.	Remarks
JK601 △	SJS9231-1B	JACK	1	
JK701	RJJ33T01	JACK	1	
L1 △	SLQZ650MH49	COIL	1	
L391,9 2	ELEXT1ROKA9	COIL	2	
L701	ELEXT101KA9	COIL	1	
L801	ELEXT101KA9	COIL	1	
L802	ELEXT100KA9	COIL	1	
P1	RPQ0164	PAD	1	
P2	REF0139	PROTECTION COVER	1	
P3	RPG4456	PACKING CASE	1	(E) <K>
P3	RPG4458	PACKING CASE	1	(E) <N>
P3	RPG4573	PACKING CASE	1	(EB) <K>
P3	RPG4459	PACKING CASE	1	(EB) <N>
P3	RPG4457	PACKING CASE	1	(EG) <K>
P3	RPG4572	PACKING CASE	1	(EG) <N>
P4	RPN1206	PAD	1	
P5	SPP756	PROTECTION COVER	1	
P6	RPQ0976	PAD	1	(EB)
PCB1	REP2840A-M	MAIN PCB	1	(RTL)
PCB2	REP2841A-S	PANEL PCB	1	(RTL)
Q201	DTC124EST	TRANSISTOR	1	
Q202	DTA124ESTP	TRANSISTOR	1	
Q203	DTC124EST	TRANSISTOR	1	
Q204	DTA124ESTP	TRANSISTOR	1	
Q301	2SK330GRYTA	TRANSISTOR	1	
Q501	DTA124ESTP	TRANSISTOR	1	
Q502	DTC124EST	TRANSISTOR	1	
Q511	2SK330GRYTA	TRANSISTOR	1	
Q521	DTC124EST	TRANSISTOR	1	
Q522	DTA124ESTP	TRANSISTOR	1	
Q551- 54	2SD1915FTA	TRANSISTOR	4	
Q555	2SA1048GR	TRANSISTOR	1	
Q581- 84	2SD1915FTA	TRANSISTOR	4	
Q601 △	2SD2037EFTA	TRANSISTOR	1	
Q602 △	2SB1357EFTA	TRANSISTOR	1	
Q603	DTA124ESTP	TRANSISTOR	1	
Q604,0 5 △	2SK301PQTA	TRANSISTOR	2	
Q606 △	2SA1048GR	TRANSISTOR	1	
Q614	2SB1357EFTA	TRANSISTOR	1	
Q615	2SB621A-R	TRANSISTOR	1	
Q616	2SA1048GR	TRANSISTOR	1	
Q617	DTC144ESTP	TRANSISTOR	1	
Q618	DTC124EST	TRANSISTOR	1	
Q619	DTA124ESTP	TRANSISTOR	1	
Q620	DTC124EST	TRANSISTOR	1	
Q621	DTA124ESTP	TRANSISTOR	1	
Q624 △	2SD592AR	TRANSISTOR	1	
Q701	DTC114ESTP	TRANSISTOR	1	
Q702	DTC114YSTP	TRANSISTOR	1	
Q706	DTA114YSTP	TRANSISTOR	1	
Q708	DTA114YSTP	TRANSISTOR	1	
Q710	DTC114YSTP	TRANSISTOR	1	
R101,0 2	ERDS2FJ152	1/4W 1.5K	2	
R103,0 4	ERDS2FJ224	1/4W 220K	2	

Ref. No.	Part No.	Part Name & Description	Pcs.	Remarks
R105,0 6	ERDS2FJ563	1/4W 56K	2	
R117,1 8	ERDS2FJ181	1/4W 180	2	
R123,2 4	ERDS2FJ680	1/4W 68	2	
R125,2 6	ERDS2FJ123	1/4W 12K	2	
R127,2 8	ERDS2FJ184	1/4W 180K	2	
R129,3 0	ERDS2FJ563	1/4W 56K	2	
R131,3 2	ERDS2FJ102	1/4W 1K	2	
R201- 12	ERDS2FJ102	1/4W 1K	12	
R215- 17	ERDS2FJ103	1/4W 10K	3	
R219- 21	ERDS2FJ103	1/4W 10K	3	
R222,2 3	ERDS2FJ102	1/4W 1K	2	
R224	ERDS2FJ472	1/4W 4.7K	1	
R227	ERDS2FJ472	1/4W 4.7K	1	
R251- 58	ERDS2FJ102	1/4W 1K	8	
R301,0 2	ERDS2FJ273	1/4W 27K	2	
R303,0 4	ERDS2FJ104	1/4W 100K	2	
R311,1 2	ERDS2FJ224	1/4W 220K	2	
R315,1 6	ERDS2FJ272	1/4W 2.7K	2	
R321,2 2	ERDS2FJ152	1/4W 1.5K	2	
R323,2 4	ERDS2FJ821	1/4W 820	2	
R331,3 2	ERDS2FJ273	1/4W 27K	2	
R333,3 4	ERDS2FJ104	1/4W 100K	2	
R341,4 2	ERDS2FJ224	1/4W 220K	2	
R351,5 2	ERDS2FJ122	1/4W 1.2K	2	
R353,5 4	ERDS2FJ681	1/4W 680	2	
R361,6 2	ERDS2FJ273	1/4W 27K	2	
R363,6 4	ERDS2FJ104	1/4W 100K	2	
R371,7 2	ERDS2FJ224	1/4W 220K	2	
R381,8 2	ERDS2FJ122	1/4W 1.2K	2	
R383,8 4	ERDS2FJ681	1/4W 680	2	
R391 △	ERDS1FJ100	1/2W 10	1	
R401,0 2	ERDS2FJ472	1/4W 4.7K	2	
R403- 06	ERDS2FJ224	1/4W 220K	4	
R407,0 8	ERDS2FJ392	1/4W 3.9K	2	
R409,1 0	ERDS2FJ102	1/4W 1K	2	
R411,1 2	ERDS2FJ183	1/4W 18K	2	
R413,1 4	ERDS2FJ392	1/4W 3.9K	2	
R415- 18	ERDS2FJ223	1/4W 22K	4	
R501,0 2	ERDS2FJ561	1/4W 560	2	
R503,0 4	ERDS2FJ332	1/4W 3.3K	2	
R505 △	ERDS1FJ101	1/2W 100	1	

Ref. No.	Part No.	Part Name & Description	Pcs.	Remarks
R511,1 2	ERDS2FJ470	1/4W 47	2	
R513,1 4	ERDS2FJ332	1/4W 3.3K	2	
R521,2 2	ERDS2FJ331	1/4W 330	2	
R523,2 4	ERDS2FJ473	1/4W 47K	2	
R525,2 6	ERDS2FJ101	1/4W 100	2	
R527 △	ERDS1FJ101	1/2W 100	1	
R541- 44	ERDS2FJ332	1/4W 3.3K	4	
R551,5 2	ERDAS3J271T	1/4W 270	2	
R553,5 4	ERDS2FJ221	1/4W 220	2	
R555,5 6	ERDS2FJ473	1/4W 47K	2	
R557- 60	ERDS2FJ102	1/4W 1K	4	
R561	ERDS2FJ272	1/4W 2.7K	1	
R562	ERDS2FJ273	1/4W 27K	1	
R563	ERDS2FJ474	1/4W 470K	1	
R571- 74	ERDS2FJ332	1/4W 3.3K	4	
R581,8 2	ERDAS3J271T	1/4W 270	2	
R583,8 4	ERDS2FJ221	1/4W 220	2	
R585,8 6	ERDS2FJ473	1/4W 47K	2	
R587- 90	ERDS2FJ102	1/4W 1K	4	
R603,0 4	ERDS2FJ101	1/4W 100	2	
R605,0 6	ERDS2FJ183	1/4W 18K	2	
R607	ERDS2FJ272	1/4W 2.7K	1	
R609,1 0 △	ERDS1FJ270	1/2W 27	2	
R618 △	ERDS1FJ8R2	1/2W 8.2	1	
R619	ERDS2FJ102	1/4W 1K	1	
R620	ERDS2FJ182	1/4W 1.8K	1	
R621	ERDS2FJ821	1/4W 820	1	
R622	ERDS2FJ223	1/4W 22K	1	
R623	ERDS2FJ153	1/4W 15K	1	
R624	ERDS2FJ473	1/4W 47K	1	
R625	ERDS2FJ104	1/4W 100K	1	
R626	ERDS2FJ473	1/4W 47K	1	
R627	EROS2TKF221 3	1/4W 221K	1	
R628	EROS2TKF374 2	1/4W 37.4K	1	
R629	ERDS2FJ102	1/4W 1K	1	
R829	ERDS2FJ103	1/4W 10K	1	
R630	EROS2TKF402 2	1/4W 40.2K	1	
R631	EROS2TKF180 2	1/4W 18K	1	
R633,3 4	ERDS2FJ182	1/4W 1.8K	2	
R635- 37 △	ERDS1FJ101	1/2W 100	3	
R639,4 0 △	ERDS1FJ101	1/2W 100	2	
R655	ERDS2FJ103	1/4W 10K	1	
R656 △	ERQ16NKWR15 E	1/6W 0.15	1	
R701	ERDS2FJ681	1/4W 680	1	
R702,0 3	ERDS2FJ103	1/4W 10K	2	
R704,0 5	ERDS2FJ104	1/4W 100K	2	

Ref. No.	Part No.	Part Name & Description	Pcs.	Remarks
R706	ERDS2FJ103	1/4W 10K	1	
R707- 09	ERDS2FJ104	1/4W 100K	3	
R710	ERDS2FJ103	1/4W 10K	1	
R713	ERDS2FJ102	1/4W 1K	1	
R724,2 5	ERDS2FJ103	1/4W 10K	2	
R726	ERDS2FJ102	1/4W 1K	1	
R727	ERDS2FJ103	1/4W 10K	1	
R728	ERDS2FJ104	1/4W 100K	1	
R729	ERDS2FJ103	1/4W 10K	1	
R801	ERDS2FJ821	1/4W 820	1	
R802	ERDS2FJ102	1/4W 1K	1	
R803	ERDS2FJ122	1/4W 1.2K	1	
R804	ERDS2FJ152	1/4W 1.5K	1	
R805	ERDS2FJ182	1/4W 1.8K	1	
R806	ERDS2FJ222	1/4W 2.2K	1	
R807	ERDS2FJ332	1/4W 3.3K	1	
R808	ERDS2FJ472	1/4W 4.7K	1	
R809	ERDS2FJ682	1/4W 6.8K	1	
R810	ERDS2FJ123	1/4W 12K	1	
R811	ERDS2FJ223	1/4W 22K	1	
R812	ERDS2FJ561	1/4W 560	1	
R813,1 4	ERDS2FJ181	1/4W 180	2	
R815	ERDS2FJ331	1/4W 330	1	
R817	ERDS2FJ331	1/4W 330	1	
R818	ERDS2FJ181	1/4W 180	1	
R819	ERDS2FJ271	1/4W 270	1	
R820	ERDS2FJ223	1/4W 22K	1	
R821	ERDS2FJ123	1/4W 12K	1	
R822	ERDS2FJ331	1/4W 330	1	
R823	ERDS2FJ181	1/4W 180	1	
R824,2 5	ERDS2FJ331	1/4W 330	2	
R826,2 7	ERDS2FJ101	1/4W 100	2	
R828,2 9	ERDS2FJ103	1/4W 10K	2	
RL201 02	RSY0020M-R	RELAY	2	
RL501	RSY0020M-R	RELAY	1	
RL521	RSY0020M-R	RELAY	1	
RL611 12	RSY0020M-R	RELAY	2	
S1 △	ESB92S22B	SW	1	
S801- 03	EVQ21405R	SW	3	
S804	RSR9A001-A	SW	1	
S805	RSP2B023-A	SW	1	
T1 △	RTP7B5B001- W	POWER TRANSFORMER	1	
VR301	RRV18J01B14 A	VR	1	
VR321, 22	EVNDXAA00B3	VR	2	
VR401	EVJ02QF01G1 5	VR	1	
VR402, 03	EVJYA1F01C1 5	VR	2	
X701	RSKY8M00D01 T	OSCILLATOR	1	
Z801	RCD12042TH	COMPONENT COMBINATION	1	

15 Cabinet Parts Location

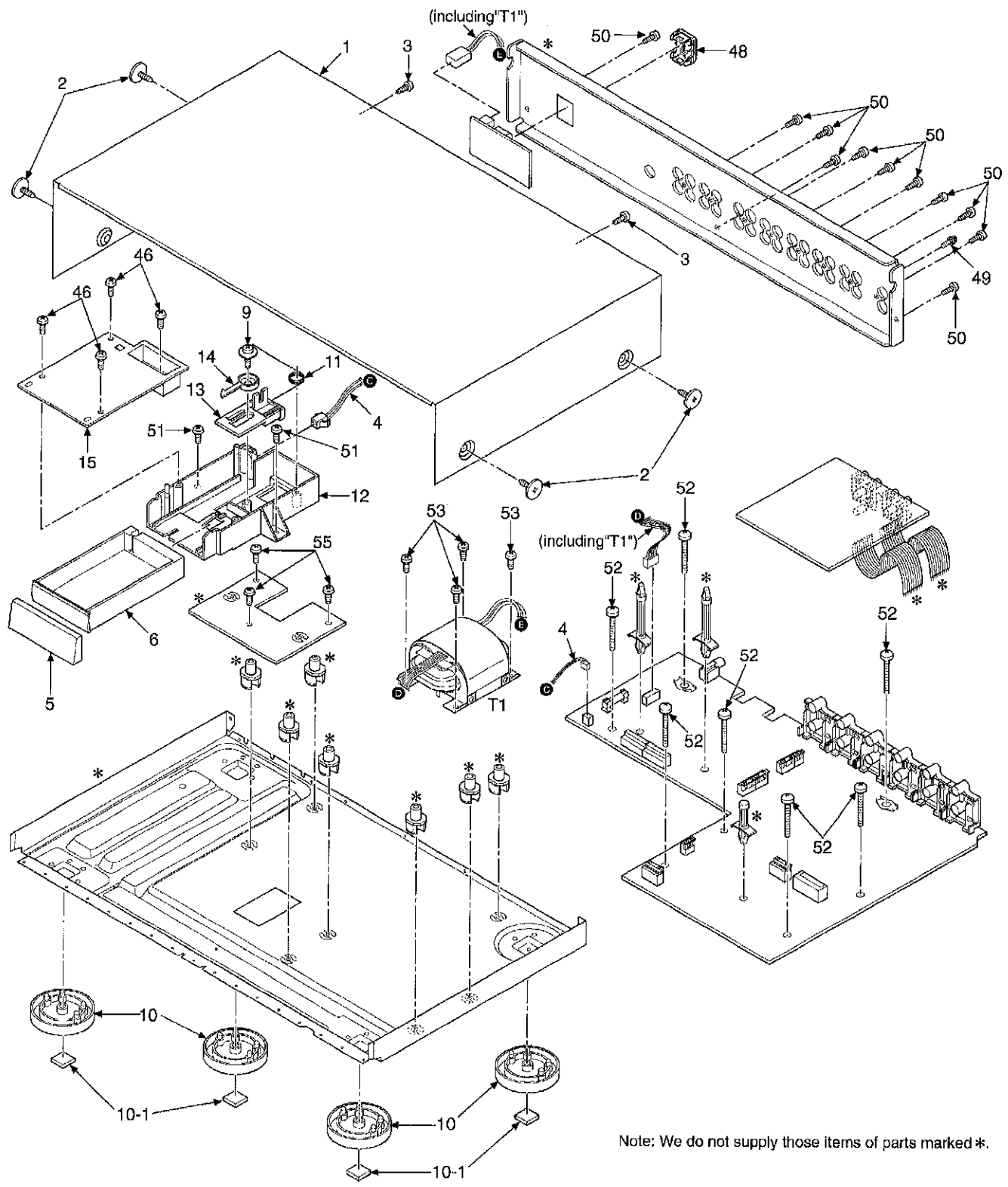

Note: We do not supply those items of parts marked *.

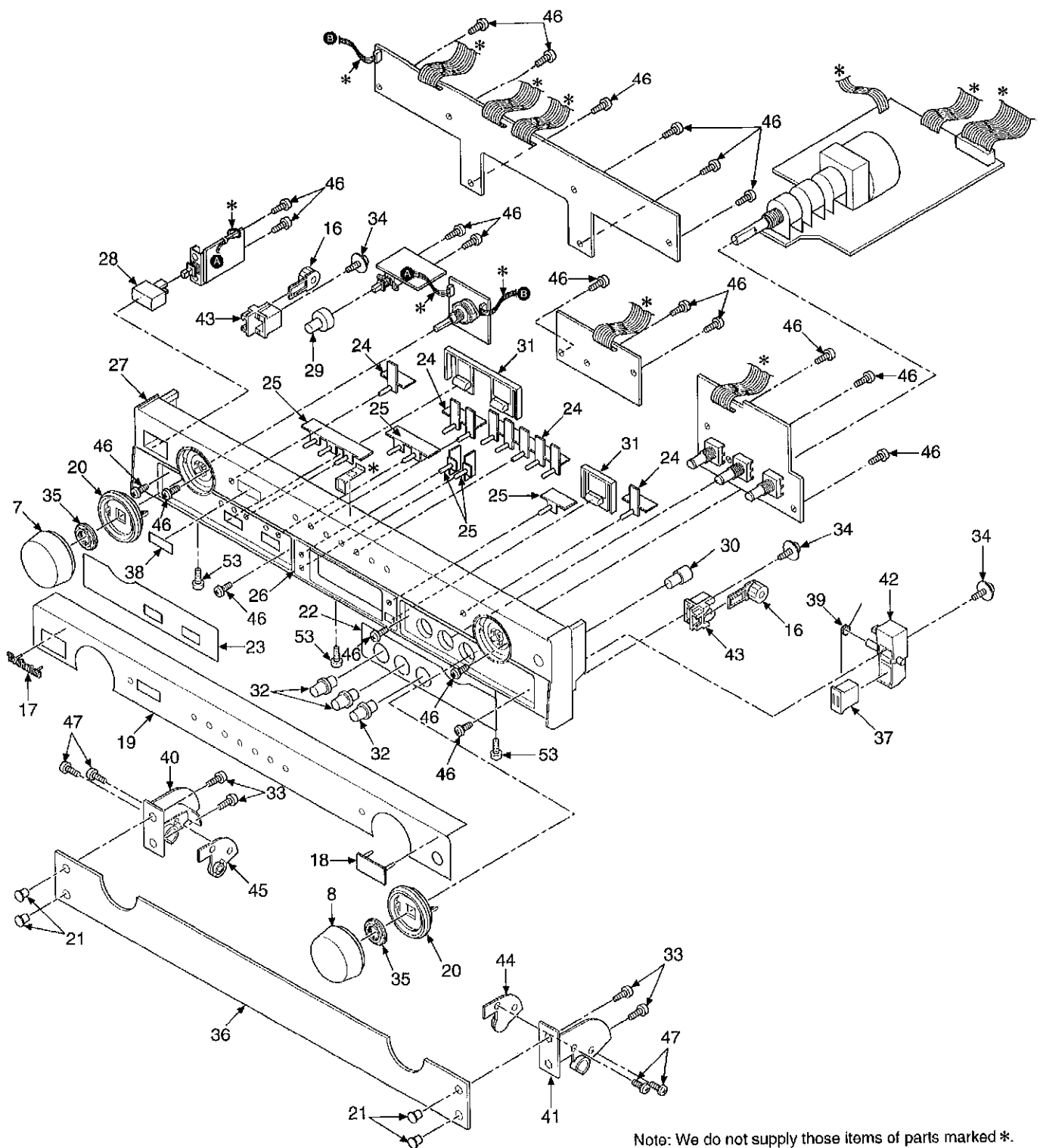

Note: We do not supply those items of parts marked *.

16 Packaging

