

Service Manual

Stereo Integrated Amplifier

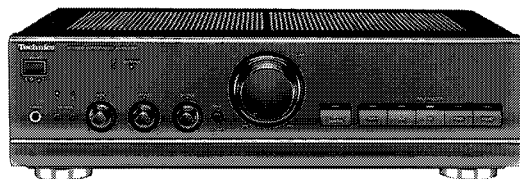

SU-V300M2

Colour

(K).....Black Type

Areas

(E).....Europe.

(EB).....Great Britain.

(EG).....Germany.

Specifications

MAIN AMP section

Power output [at power supply 240 V for (EB) area]:

40 Hz – 20 kHz continuous power output both channels driven;	2 × 27 W (8 Ω)
1 kHz continuous power output both channels driven (THD: 1 %):	2 × 33 W (8 Ω) 2 × 40 W (4 Ω)
63 Hz – 12.5 kHz continuous power output both channels driven (THD: 1 %):	2 × 30 W (8 Ω) 2 × 35 W (4 Ω)

Total harmonic distortion:

rated power at 20 Hz – 20 kHz;	0.2 % (8 Ω)
Intermodulation distortion (50 Hz: 7 kHz = 4 : 1, SMPTE):	0.2 % (8 Ω)
rated power;	1 mV
Residual hum and noise:	60 (8 Ω) 30 (4 Ω)
Damping factor:	240 mV/47 Ω

Headphones output level/impedance:

Load impedance:	4 Ω – 16 Ω
A or B;	8 Ω – 16 Ω
A and B;	

PRE AMP section

Input sensitivity/impedance:

PHONO MM;	2.5 mV/47 kΩ
TUNER, CD, AUX, TAPE1, TAPE2;	150 mV/22 kΩ
Input capacitance:	270 pF
PHONO maximum input voltage (1 kHz, RMS):	150 mV (IHF '66)
MM;	
S/N (Rated power, 4 Ω):	
PHONO MM;	76 dB (76 dB, IHF '66)
TUNER, CD, AUX, TAPE1, TAPE2;	90 dB (76 dB, IHF '66)

S/N at –26 dB power (4 Ω):

PHONO MM;	67 dB
TUNER, CD, AUX, TAPE1, TAPE2;	70 dB
S/N at 50 mW (4 Ω):	
PHONO MM;	63 dB
TUNER, CD, AUX, TAPE1, TAPE2;	63 dB

Frequency response:

PHONO MM;	RIAA standard curve ±1 dB (30 Hz – 15 kHz)
TUNER, CD, AUX, TAPE1, TAPE2;	+0, –3 dB (3 Hz – 60 kHz) +0, –0.3 dB (20 Hz – 20 kHz)

Tone controls:

BASS;	50 Hz, +10 dB to –10 dB
TREBLE;	20 kHz, +10 dB to –10 dB

Output voltage:

TAPE1, TAPE2 REC OUT;	150 mV
Channel balance (AUX 250 Hz – 6.3 kHz):	±1 dB
Channel separation (AUX 1 kHz):	50 dB

General

Power supply:

For (E) and (EG) areas;	AC 230V, 50/60 Hz
For (EB) area;	AC 230 – 240 V, 50/60 Hz

Power consumption:

Dimensions (W × H × D):	430 × 125 × 310 mm
Weight:	5.4 kg

Notes: Specifications are subject to change without notice.

Weight and dimensions are approximate.

Total harmonic distortion is measured by the digital spectrum analyzer.

⚠ WARNING

This service information is designed for experienced repair technicians only and is not designed for use by the general public. It does not contain warnings or cautions to advise non-technical individuals of potential dangers in attempting to service a product. Products powered by electricity should be serviced or repaired only by experienced professional technicians. Any attempt to service or repair the product or products dealt with in this service information by anyone else could result in serious injury or death.

CONTENTS

Page	Page		
1 Note	2	9 Schematic Diagram Notes	8
2 Before Repairs	2	10 Schematic Diagram	9
3 Protection Circuitry	2	11 Printed Circuit Board Diagram	14
4 Accessories	2	12 Wiring Connection Diagram	18
5 Caution for AC Mains Lead	3	13 Block Diagram	19
6 Location of Controls	4	14 Terminal Function of ICs	20
7 Operation Checks and Component Replacement Procedures	5	14.1. IC801 (M37470M2536S):Micro Computer	20
7.1. Checking for the operation P.C.B. and tone amp P.C.B. ..	5	15 Replacement Parts List	20
7.2. Checking for the main P.C.B.	6	16 Cabinet Parts Location	23
7.3. Replacement for the power IC	6	17 Packaging	25
8 Type Illustration of ICs, Transistors and Diodes	8		

1 Note

- The contents changed from Model No. SU-V300M2 (Order No. AD99003072C2)

This model [SU-V300M2 (Order No. AD0104089C2)] is changed from Model No. SU-V300M2 (Order No. AD9903072C2) about Printed Circuit Board. So you need to use the service manual properly with distinguishing the unit is sold on and after April 2001 or not.

When the unit is repaired, refer to the table as shown below and confirm IC601 and Part No. of operation P.C.B.

	SU-V300M2 (AD9903072C2)	SU-V300M2 (AD0104089C2)
IC601	RSN3502A	RSN3502C
Operation P.C.B.	RJB1273BB-2	RJB1273BB-3
The time of sales	Before April 2001	On and after April 2001

2 Before Repairs

1. Turn off the power supply. Using a 10 Ω , 10 W resistor, connect both ends of power supply capacitors (C703, C704) in order to discharge the voltage.
2. Before turning the power supply on, after completion of repair, slowly apply the primary voltage by using a power supply voltage controller to make sure that the consumed current at 50 Hz in NO SIGNAL mode should be shown below with respect to supply voltage 230/240 V.

Power supply voltage	AC 230 V	AC 240 V
Consumed current 50 Hz	47 ~ 157 mA	45 ~ 150 mA

4 Accessories

- AC power supply cord for (E) and (EG) areas (RJA0019-1X).....1 pc.

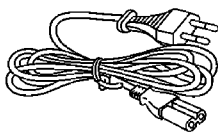

- AC power supply cord for (EB) area (RJA0035-2X).....1 pc.

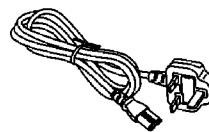

5 Caution for AC Mains Lead

(For United Kingdom)

("EB" area code model only)

For your safety, please read the following text carefully.

This appliance is supplied with a moulded three pin mains plug for your safety and convenience.

A 5-ampere fuse is fitted in this plug.

Should the fuse need to be replaced please ensure that the replacement fuse has a rating of 5-ampere and that it is approved by ASTA or BSI to BS1362.

Check for the ASTA mark  or the BSI mark  on the body of the fuse.

If the plug contains a removable fuse cover you must ensure that it is refitted when the fuse is replaced.

If you lose the fuse cover the plug must not be used until a replacement cover is obtained.

A replacement fuse cover can be purchased from your local dealer.

CAUTION!

IF THE FITTED MOULDED PLUG IS UNSUITABLE FOR THE SOCKET OUTLET IN YOUR HOME THEN THE FUSE SHOULD BE REMOVED AND THE PLUG CUT OFF AND DISPOSED OF SAFELY. THERE IS A DANGER OF SEVERE ELECTRICAL SHOCK IF THE CUT OFF PLUG IS INSERTED INTO ANY 13-AMPERE SOCKET.

If a new plug is to be fitted please observe the wiring code as shown below.

If in any doubt please consult a qualified electrician.

IMPORTANT

The wires in this mains lead are coloured in accordance with the following code:

Blue: Neutral, Brown: Live.

As these colours may not correspond with the coloured markings identifying the terminals in your plug, proceed as follows:

The wire which is coloured Blue must be connected to the terminal which is marked with the letter N or coloured Black or Blue.

The wire which is coloured Brown must be connected to the terminal which is marked with the letter L or coloured Brown or Red.

WARNING: DO NOT CONNECT EITHER WIRE TO THE EARTH TERMINAL WHICH IS MARKED WITH THE LETTER E, BY THE EARTH SYMBOL  OR COLOURED GREEN OR GREEN/YELLOW.

THIS PLUG IS NOT WATERPROOF—KEEP DRY.

Before use

Remove the connector cover.

How to replace the fuse

The location of the fuse differ according to the type of AC mains plug (figures A and B). Confirm the AC mains plug fitted and follow the instructions below.

Illustrations may differ from actual AC mains plug.

1. Open the fuse cover with a screwdriver.

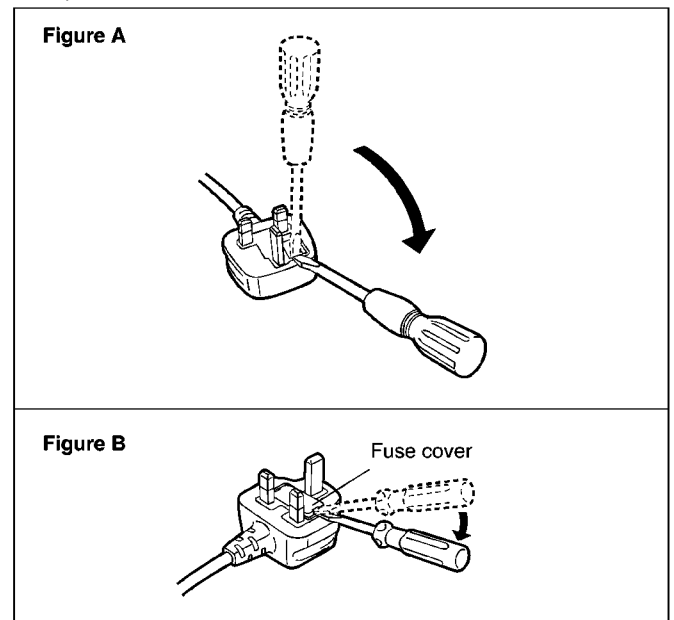



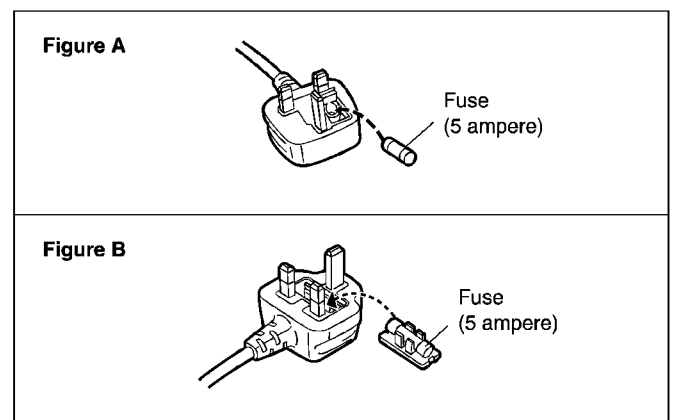

2. Replace the fuse and close or attach the fuse cover.

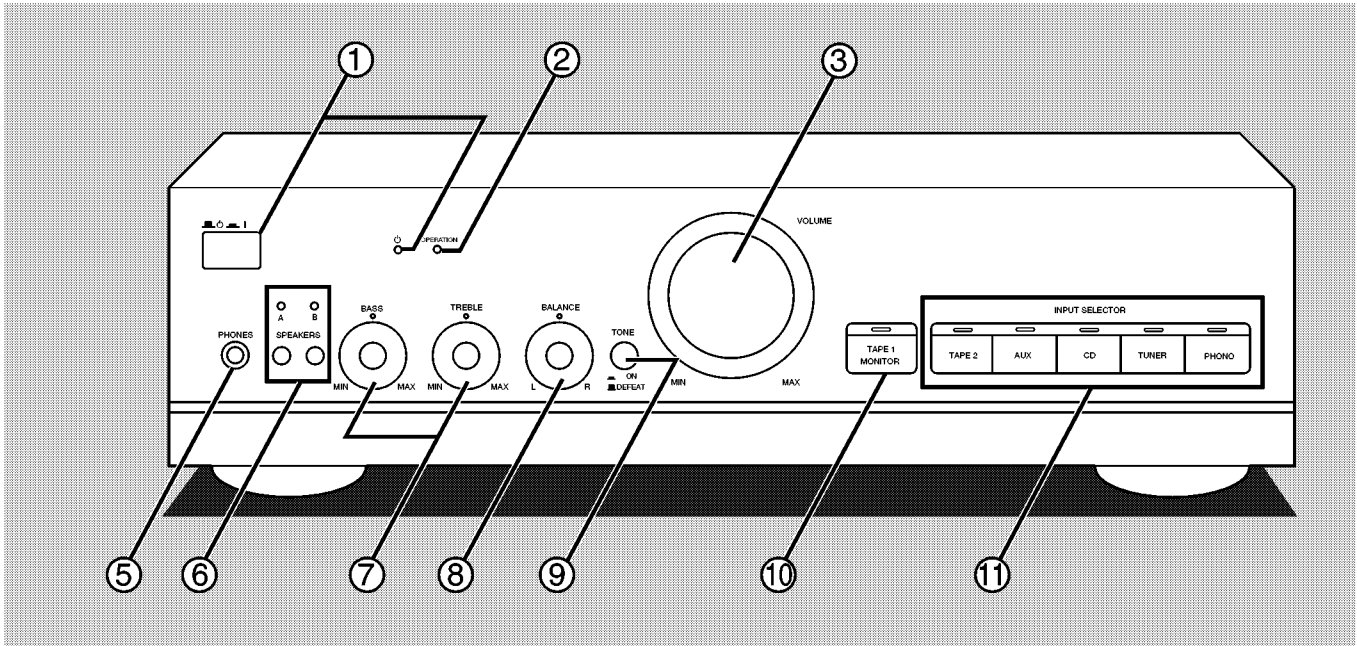

6 Location of Controls



No.	Name
-----	------

① **Unit on/off button (  ) and standby indicator ()**

Press to switch the unit from on to standby mode or visa versa.

 (off): The unit is in standby mode.

 (on): The unit is on.

In standby mode, the unit is still consuming a small amount of power.

When the unit is connected to the AC mains supply, the indicator lights up in standby mode and goes out when the unit is turned on.

No.	Name
-----	------

② **Operation indicator (OPERATION)**

When the power is switched ON, this indicator illuminates after about 2 seconds when the unit is in the operating condition.

③ **Volume control (VOLUME)**

⑤ **Headphone jack (PHONES)**

⑥ **Speaker select buttons/indicators (SPEAKERS)**

⑦ **Tone controls (BASS, TREBLE)**

⑧ **Balance control (BALANCE)**

⑨ **Tone control button (TONE)**

⑩ **TAPE 1 MONITOR button/indicator (TAPE 1 MONITOR)**

⑪ **Input select buttons/indicators (INPUT SELECTOR)**

7 Operation Checks and Component Replacement Procedures

- This section describes procedures for checking the operation of the major printed circuit boards and replacing the main components.
- For reassembly after operation checks or replacement, reverse the respective procedures. Special reassembly procedures are described only when required.

7.1. Checking for the operation P.C.B. and tone amp P.C.B.

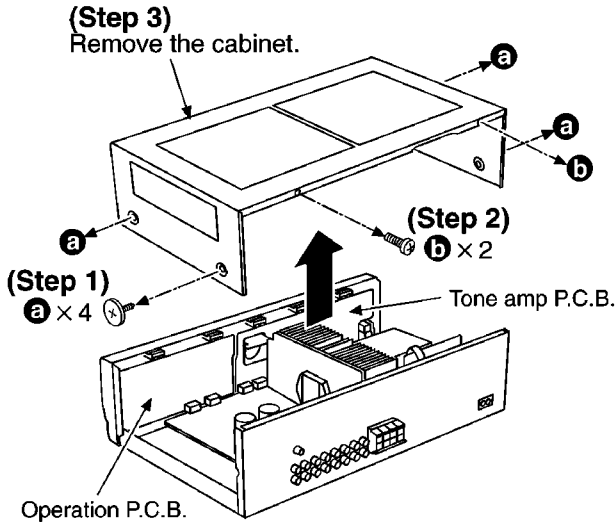

- Check the operation P.C.B. and tone amp P.C.B. as shown above.

To remove each P.C.B.

(Step 5) Pull out the front panel ass'y.

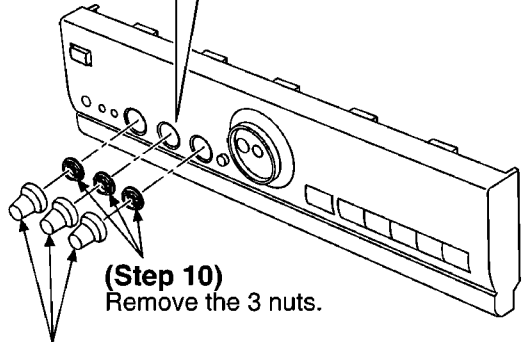
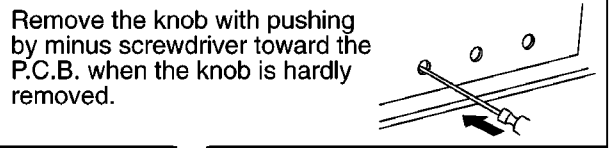
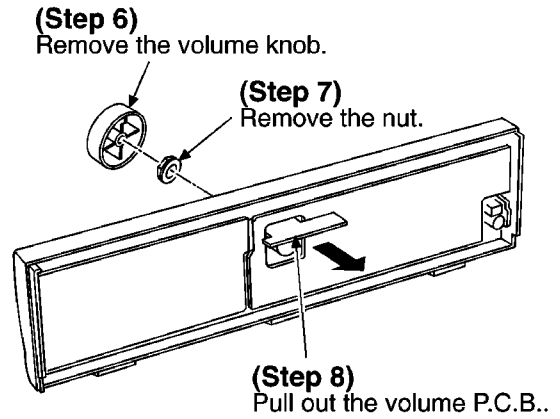
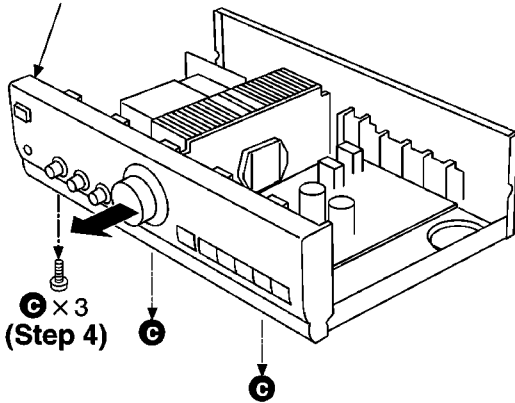

(Step 9) Remove the 3 knobs.

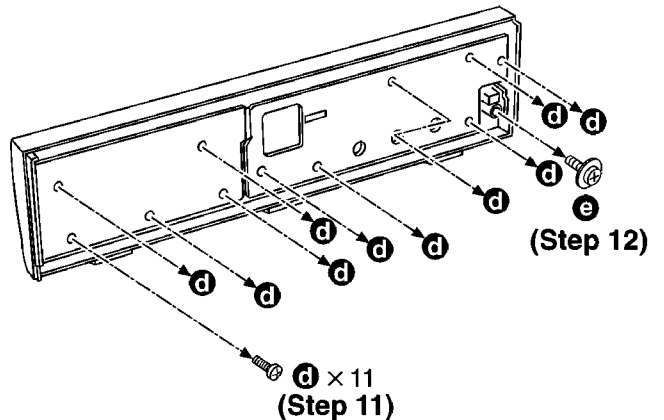

(Step 14)

Remove the connector, and then remove the operation P.C.B. and tone amp P.C.B..

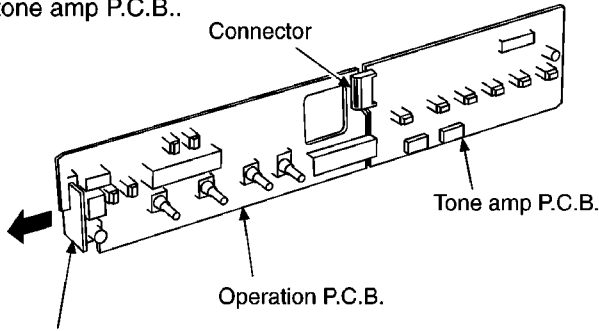

(Step 13)

Remove the headphones jack P.C.B..

7.2. Checking for the main P.C.B.

• Follow the (Step 1) - (Step 5) of item 7.1.

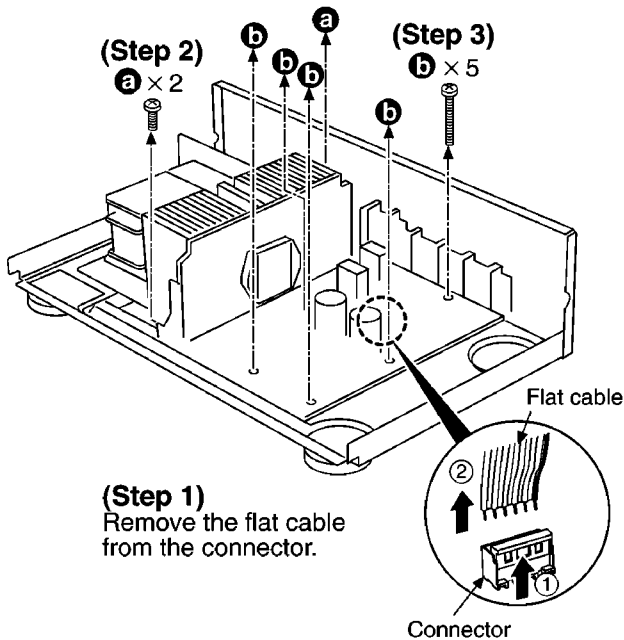

(Step 1)

Remove the flat cable from the connector.

(Step 7)

Connect the front panel ass'y of the P.C.B. connectors to the main P.C.B..

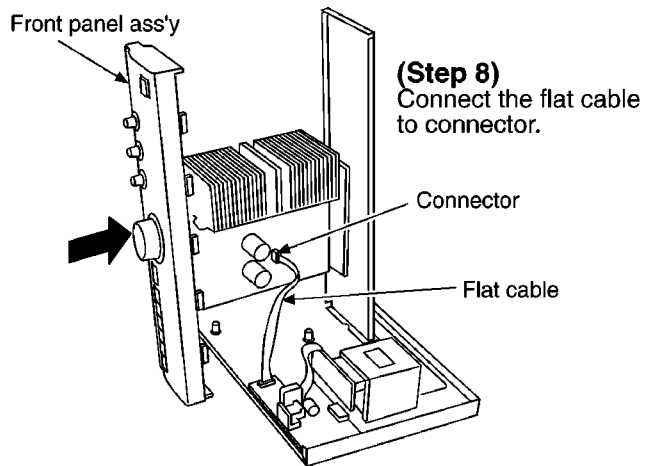

(Step 8)

Connect the flat cable to connector.

• Check the main P.C.B. as shown below.

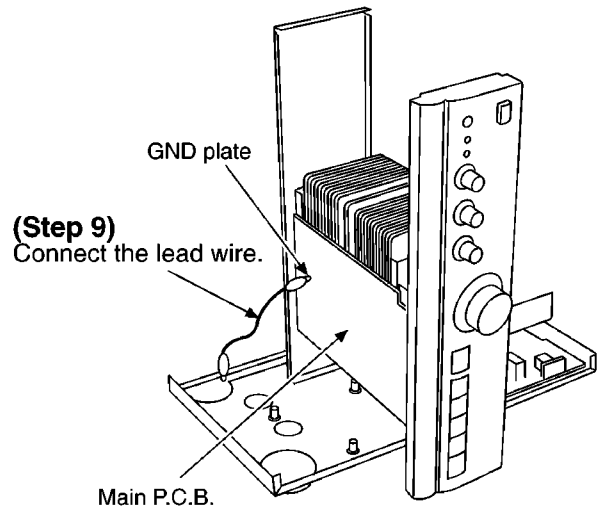

(Step 9)

Connect the lead wire.

7.3. Replacement for the power IC

• Follow the (Step 1) - (Step 3) of item 7.1.

(Step 1)

Cut the joints as shown below. (6 portions)

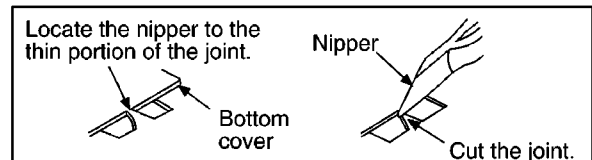

(Step 6)

Release the 2 hooks, and then remove the main P.C.B. and rear panel.

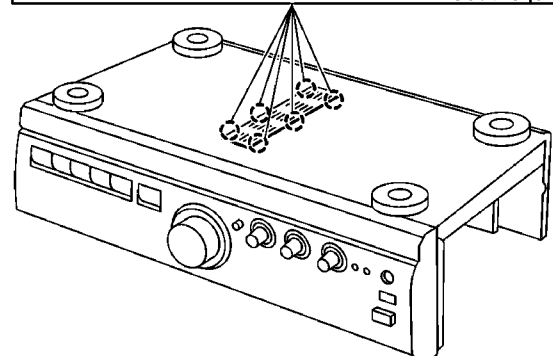
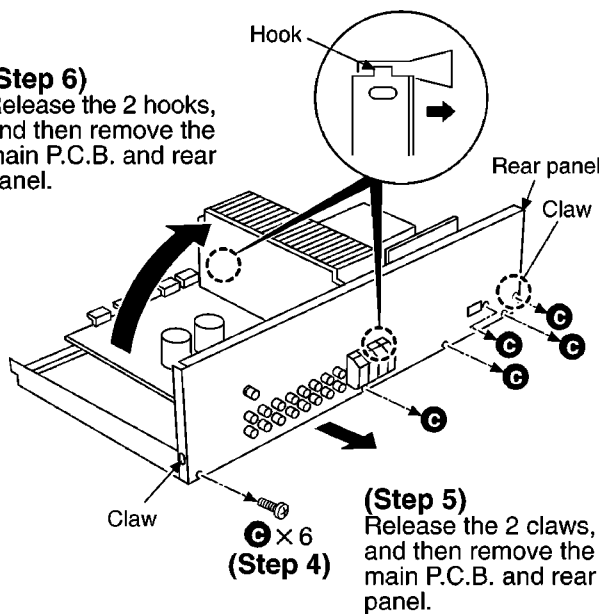

(Step 2)
Fold the joints. (6 portions)

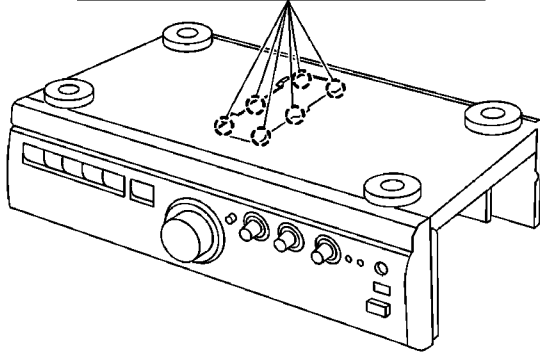
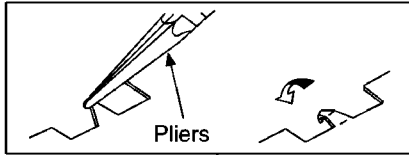

(Step 3)
Unsolder the terminals of power IC.

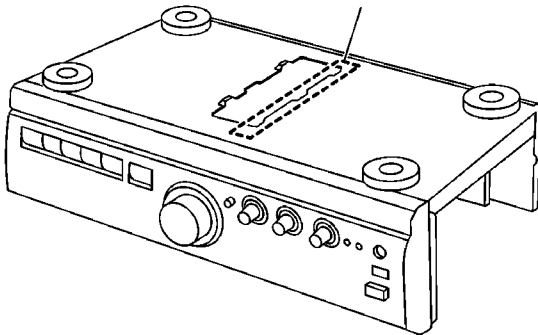

Power IC (IC601)
[RSN3502C]

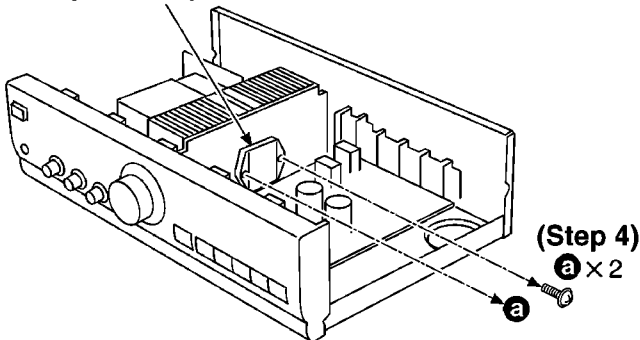

(Step 4)
a × 2

NOTE:

1. After replacing the power IC, apply a sufficient quantity of compound grease (RFKX0002) between the heat sink and the power IC (Radiation of power IC).
2. Tighten enough the screws (a) after replacing the power IC. Otherwise, the heat radiation works little.

Installation of the bottom cover after replacement

(Step 1)

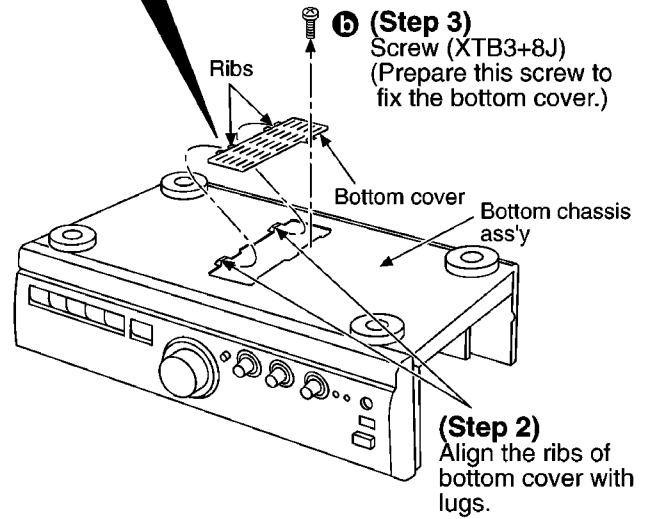
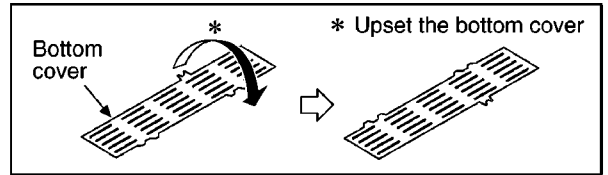

(Step 3)
Screw (XTB3+8J)
(Prepare this screw to fix the bottom cover.)

(Step 2)
Align the ribs of bottom cover with lugs.

8 Type Illustration of ICs, Transistors and Diodes

<p>M5218AP</p>	<p>M37470M2536S</p>	<p>RSN3502C</p>	<table border="1"> <tr> <td>UPC4570C</td> <td>8PIN</td> </tr> <tr> <td>NJU7312AL</td> <td>28PIN</td> </tr> <tr> <td>AN6558F</td> <td>8PIN</td> </tr> </table>	UPC4570C	8PIN	NJU7312AL	28PIN	AN6558F	8PIN	<p>2SD2037EFTA</p>
UPC4570C	8PIN									
NJU7312AL	28PIN									
AN6558F	8PIN									
<p>2SK330GRYTA</p>	<p>2SC3327ABTP DTA124ESTP</p>	<p>2SA1309AQT 2SA1309ART 2SC3311ART 2SC3312RSTTA 2SC2785FETA UN4111TA UN4211TA</p>	<p>LN014304P LN018304P</p>	<p>P300DLF</p>						
<p>MA4150MTA MA4160MTA MA4240MTA</p>	<p>MA4051MTA MA4068LTA MA4075MTA</p>	<p>MA165TA MA167ATA 1SR35200TB</p>	<p>1SS291TA</p>							

9 Schematic Diagram Notes

• This schematic diagram may be modified at any time with the development of new technology.

Notes:

- S401: Tone control switch (TONE)
- S801: Input selector switch (PHONO)
- S802: Input selector switch (TUNER)
- S803: Input selector switch (CD)
- S804: Input selector switch (AUX)
- S805: Input selector switch (TAPE2)
- S806: Tape1 monitor switch (TAPE1 MONITOR)
- S807: Unit on/off switch ()
- S808: Speaker select switch (SPEAKERS A)
- S809: Speaker select switch (SPEAKERS B)
- VR471: Bass control VR (BASS)
- VR472: Treble control VR (TREBLE)
- VR501: Volume control VR (VOLUME)
- VR502: Balance control VR (BALANCE)

• Indicated voltage values are the standard values for the unit measured by the DC electronic circuit tester (high-impedance) with the chassis taken as standard. Therefore, there may exist some errors in the voltage values, depending on the internal impedance of the DC circuit tester.

No mark : Power ON

• Important safety notice:

Components identified by mark have special characteristics important for safety.

Furthermore, special parts which have purposes of fire-

retardant (resistors), high-quality sound (capacitors), low-noise (resistors), etc. are used.

When replacing any of components, be sure to use only manufacturer's specified parts shown in the parts list.

• The supply part number is described alone in the replacement parts list.

• **Caution!**

IC and LSI are sensitive to static electricity.

Secondary trouble can be prevented by taking care during repair.

Cover the parts boxes made of plastics with aluminum foil. Ground the soldering iron.

Put a conductive mat on the work table.

Do not touch the legs of IC or LSI with the fingers directly.

• Voltage and signal line

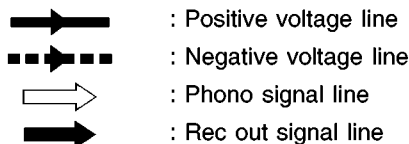

SCHEMATIC DIAGRAM-3

E MAIN CIRCUIT

— : POSITIVE VOLTAGE LINE ⇨ : PHONO SIGNAL LINE
 - - - : NEGATIVE VOLTAGE LINE ⇨ : REC OUT SIGNAL LINE

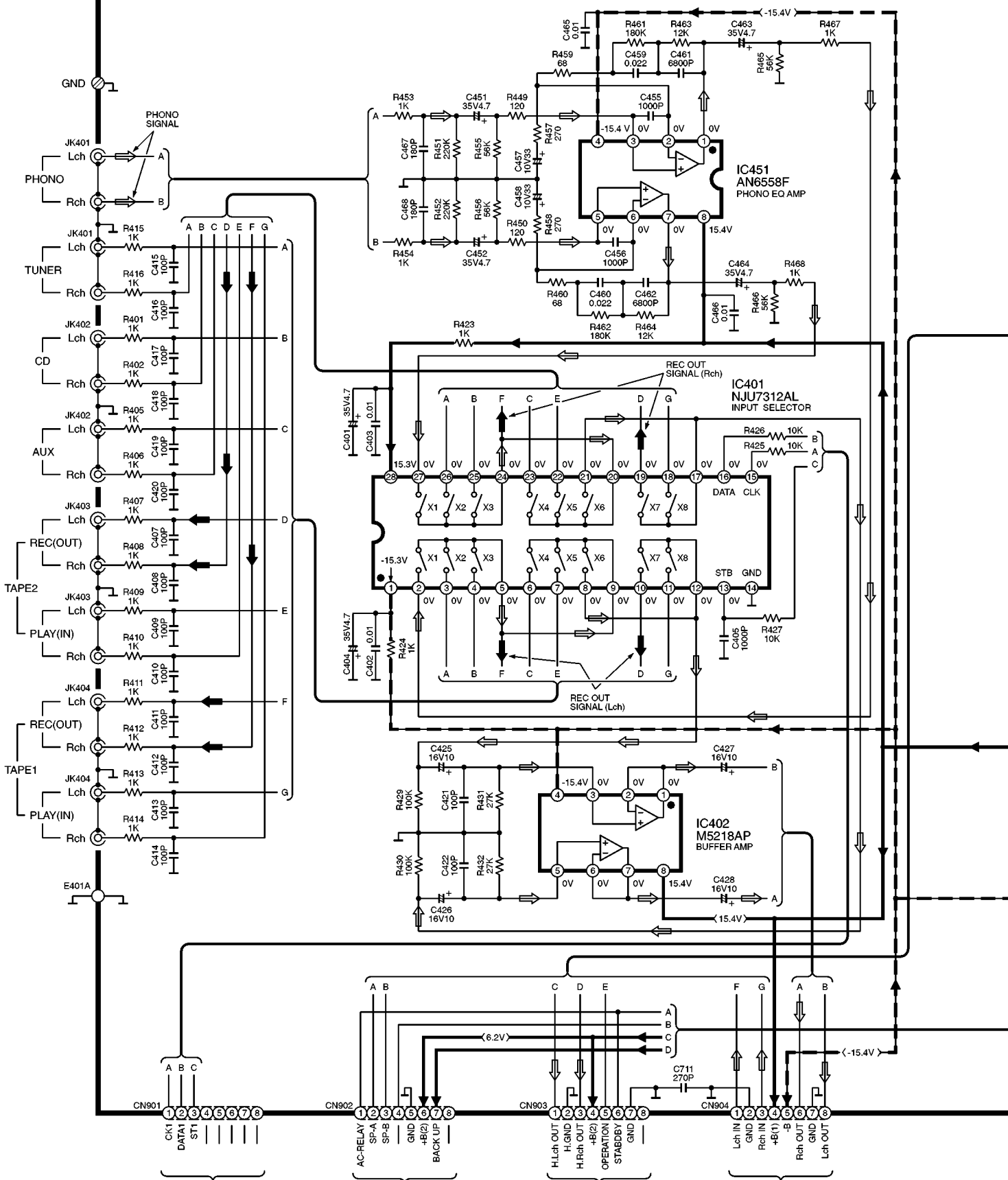

To **A** OPERATION CIRCUIT (CP901) on SCHEMATIC DIAGRAM-1 To **A** OPERATION CIRCUIT (CP902) on SCHEMATIC DIAGRAM-1
 To **C** TONE AMP CIRCUIT (CP903) on SCHEMATIC DIAGRAM-2 To **C** TONE AMP CIRCUIT (CP904) on SCHEMATIC DIAGRAM-2

SCHEMATIC DIAGRAM-4

➔ : POSITIVE VOLTAGE LINE ➔ - - : NEGATIVE VOLTAGE LINE ⇨ : PHONO SIGNAL LINE

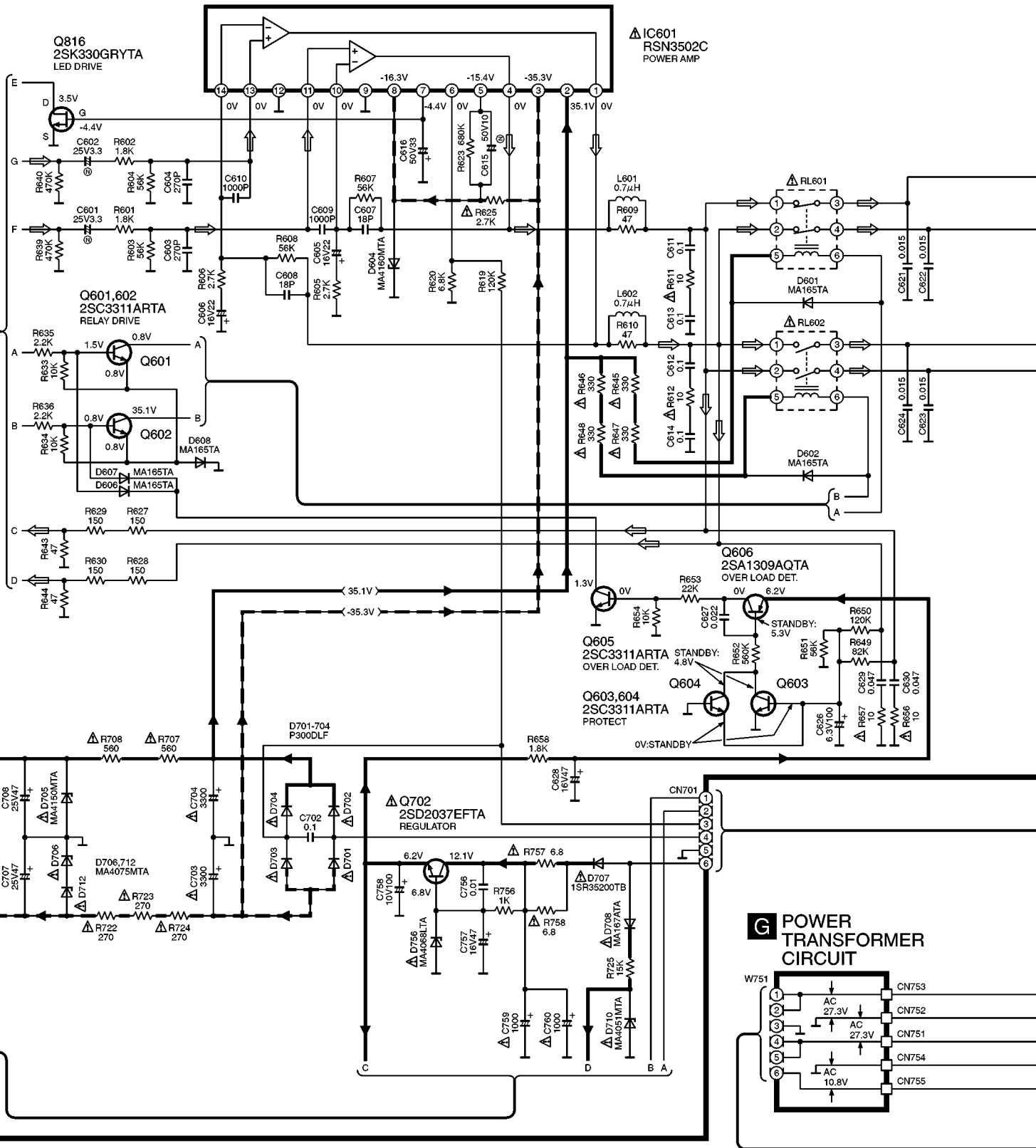

SCHEMATIC DIAGRAM-5

➔ : POSITIVE VOLTAGE LINE ⇨ : PHONO SIGNAL LINE

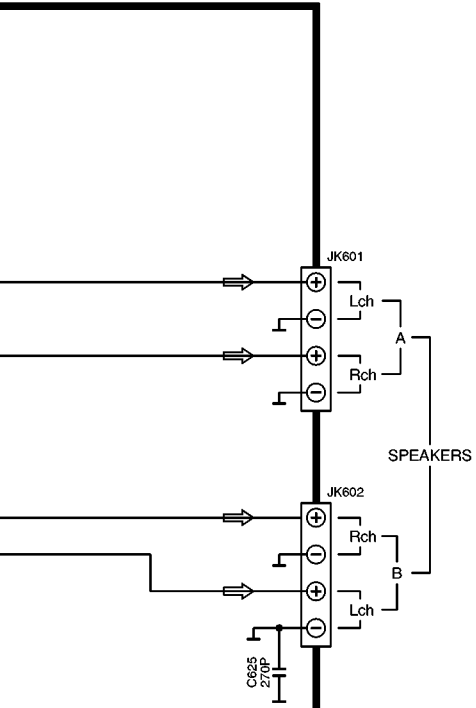

F POWER SUPPLY CIRCUIT

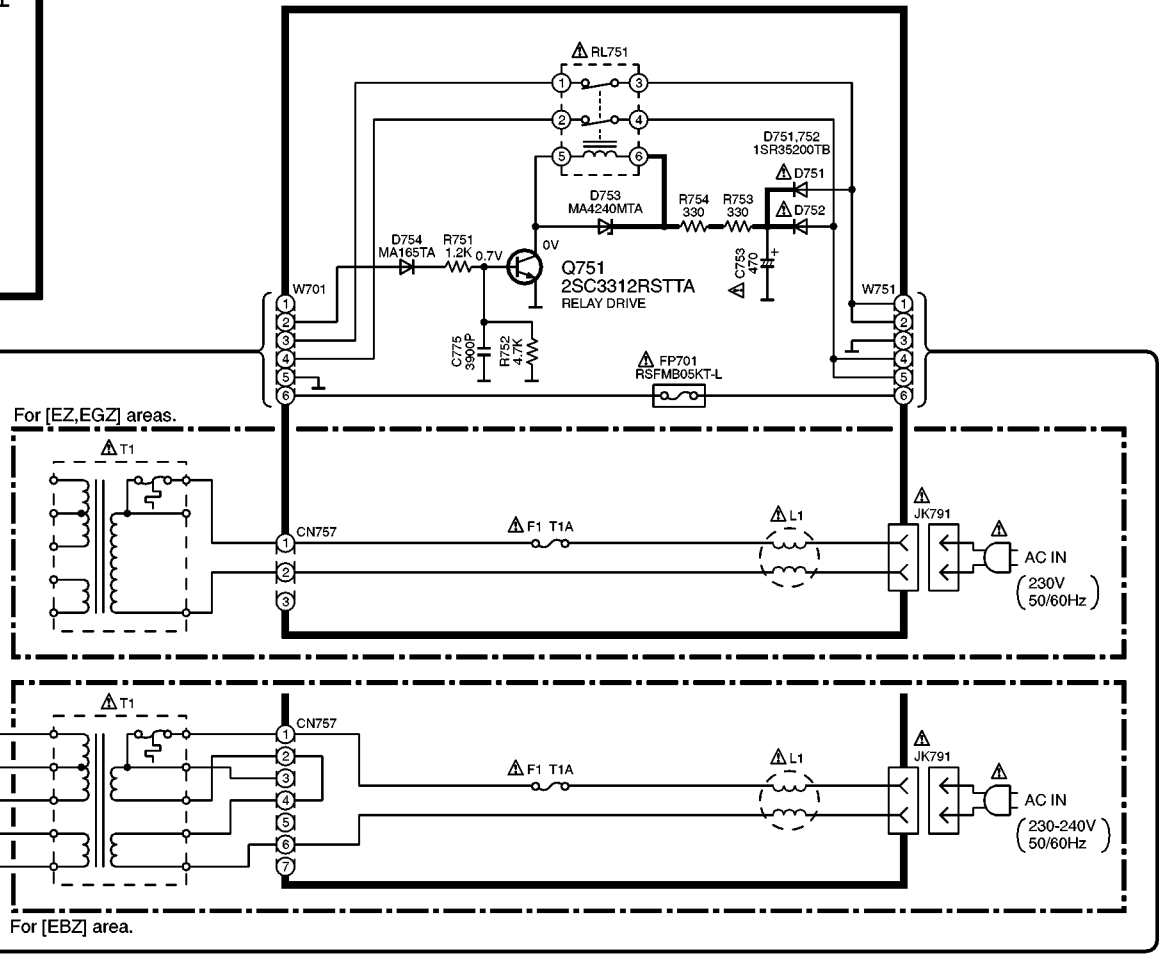

11 Printed Circuit Board Diagram

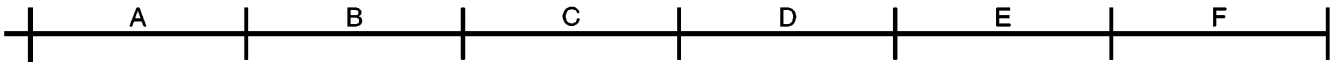

This circuit board diagram may be modified at any time with the development of new technology.

A OPERATION P.C.B.

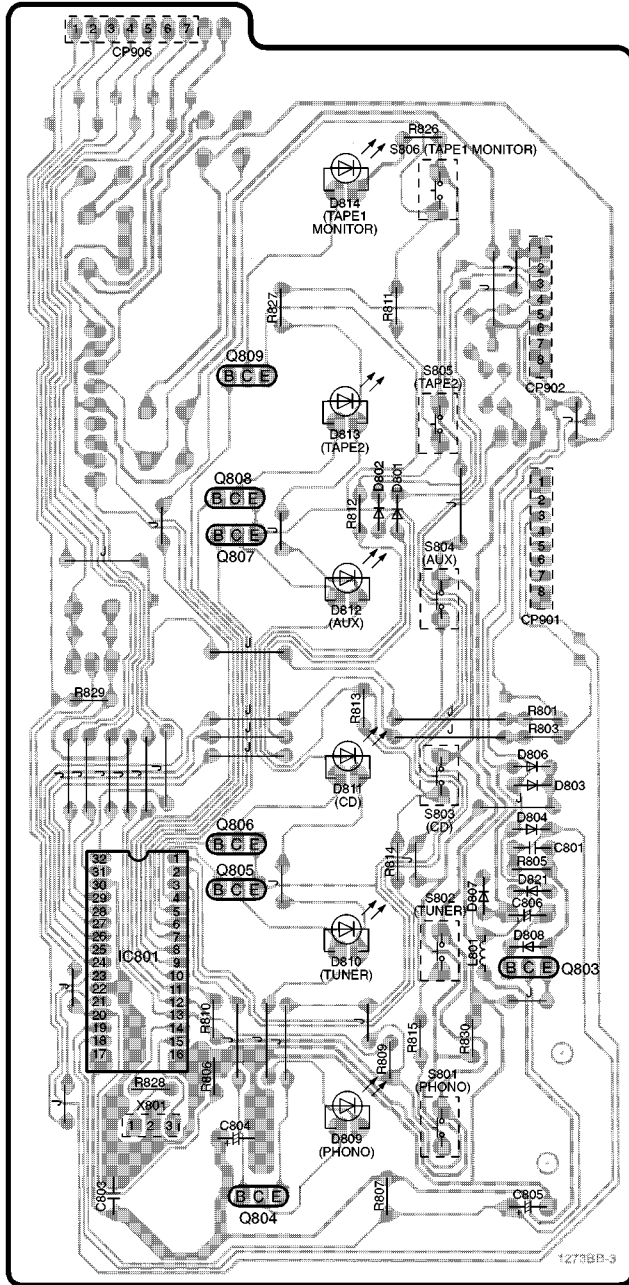

B VOLUME P.C.B.

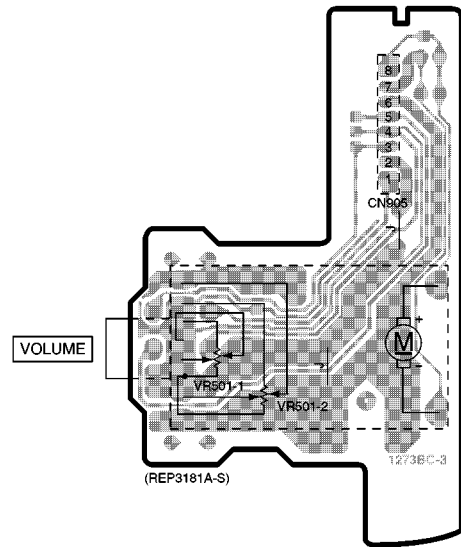

(REP3181A-S)

A B C D E F

1
2
3
4
5
6
7
8

C TONE AMP P.C.B.

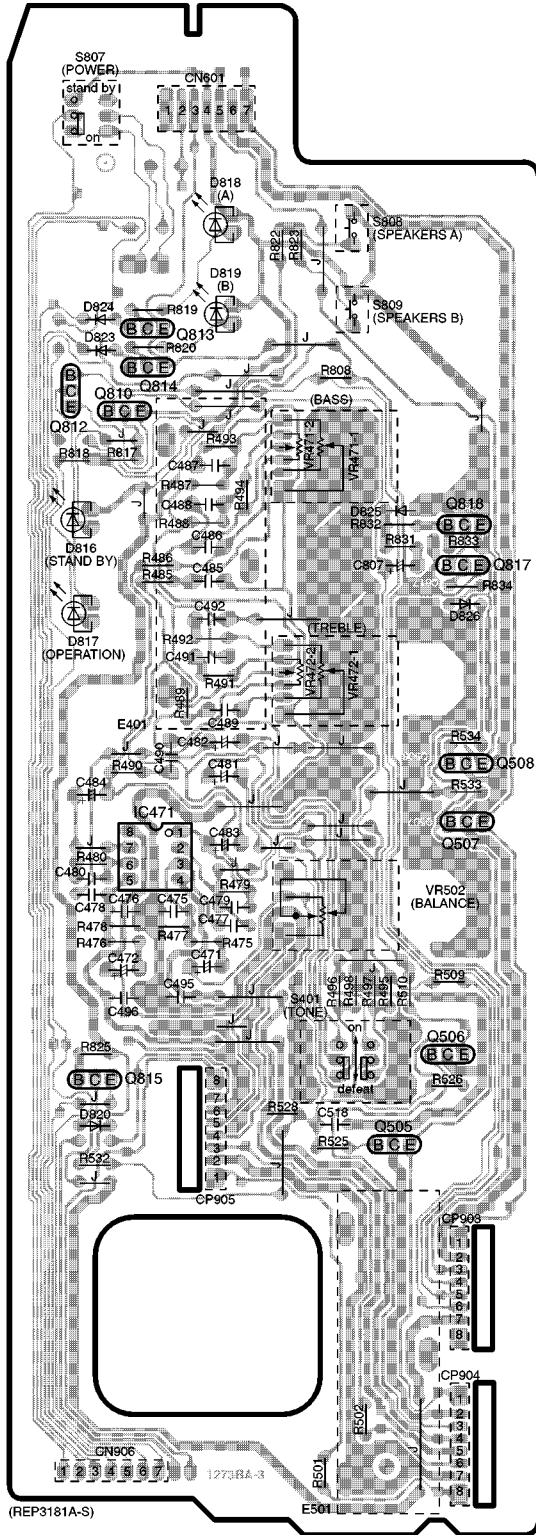

D HEADPHONES JACK P.C.B.

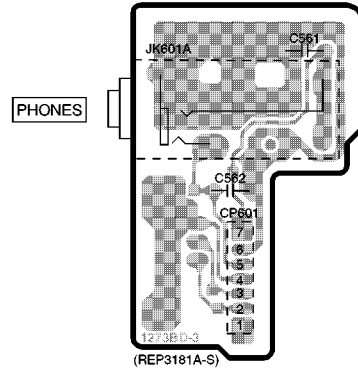

A B C D E F

1
2
3
4
5
6
7
8

E MAIN P.C.B.

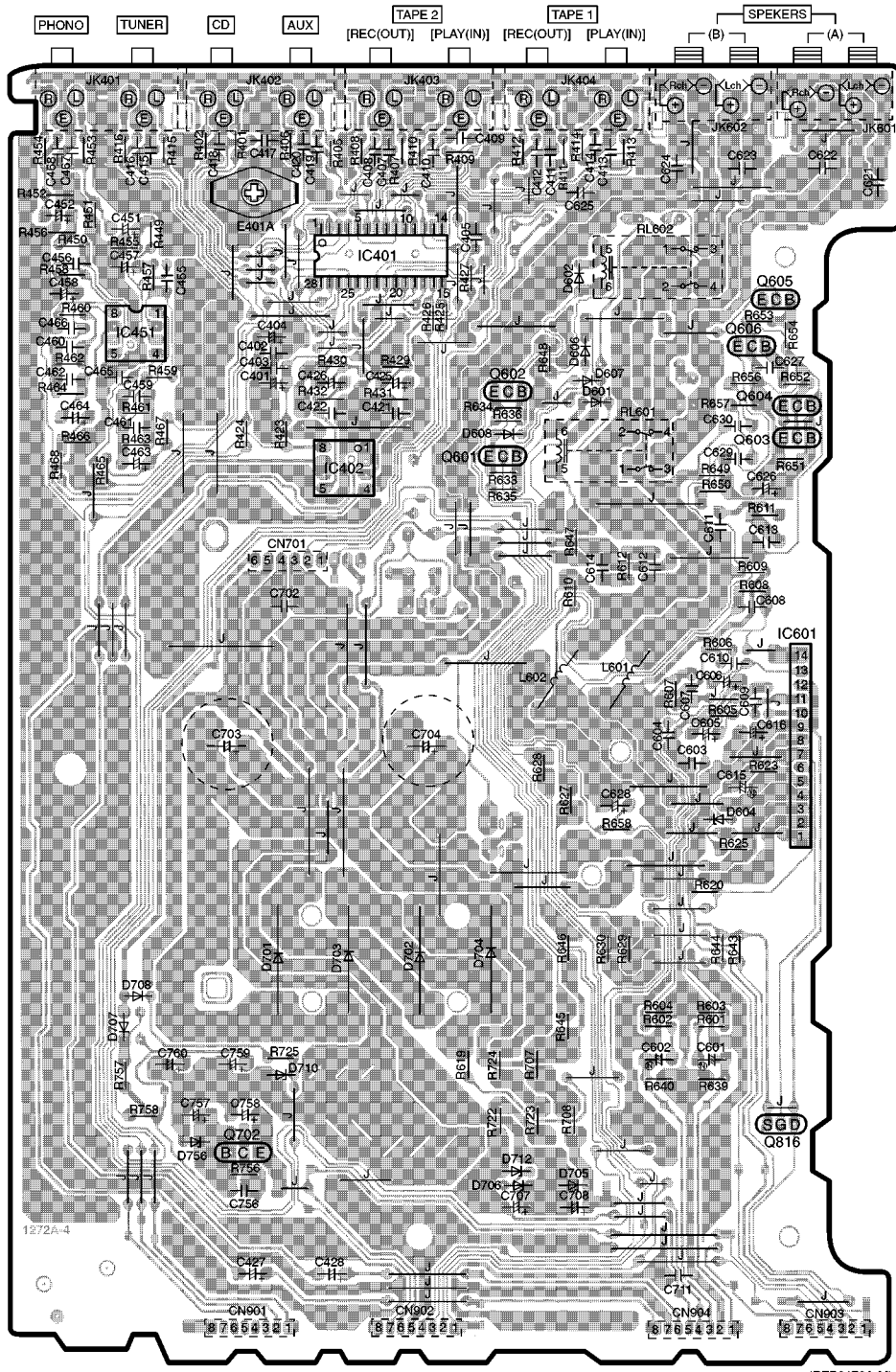

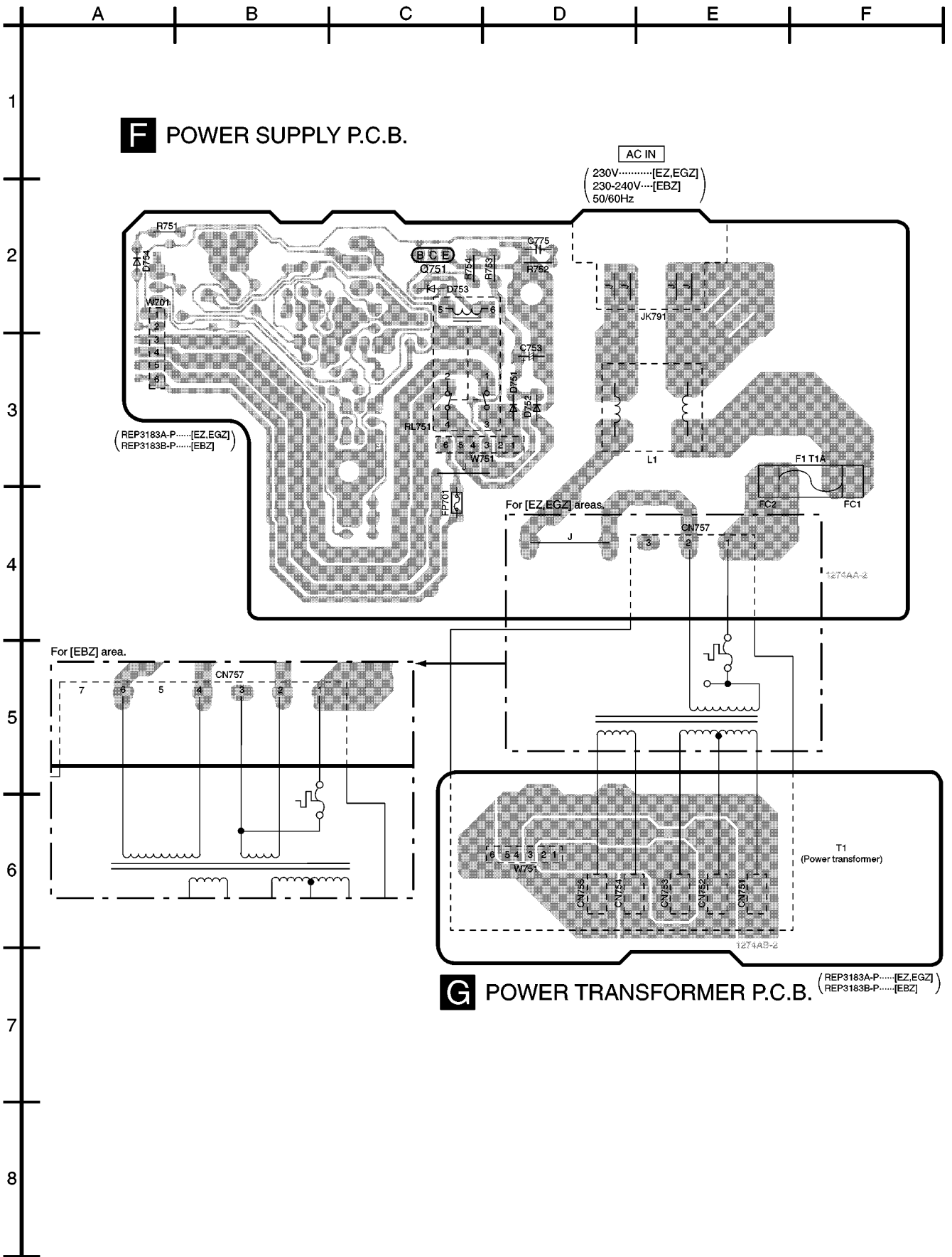

12 Wiring Connection Diagram

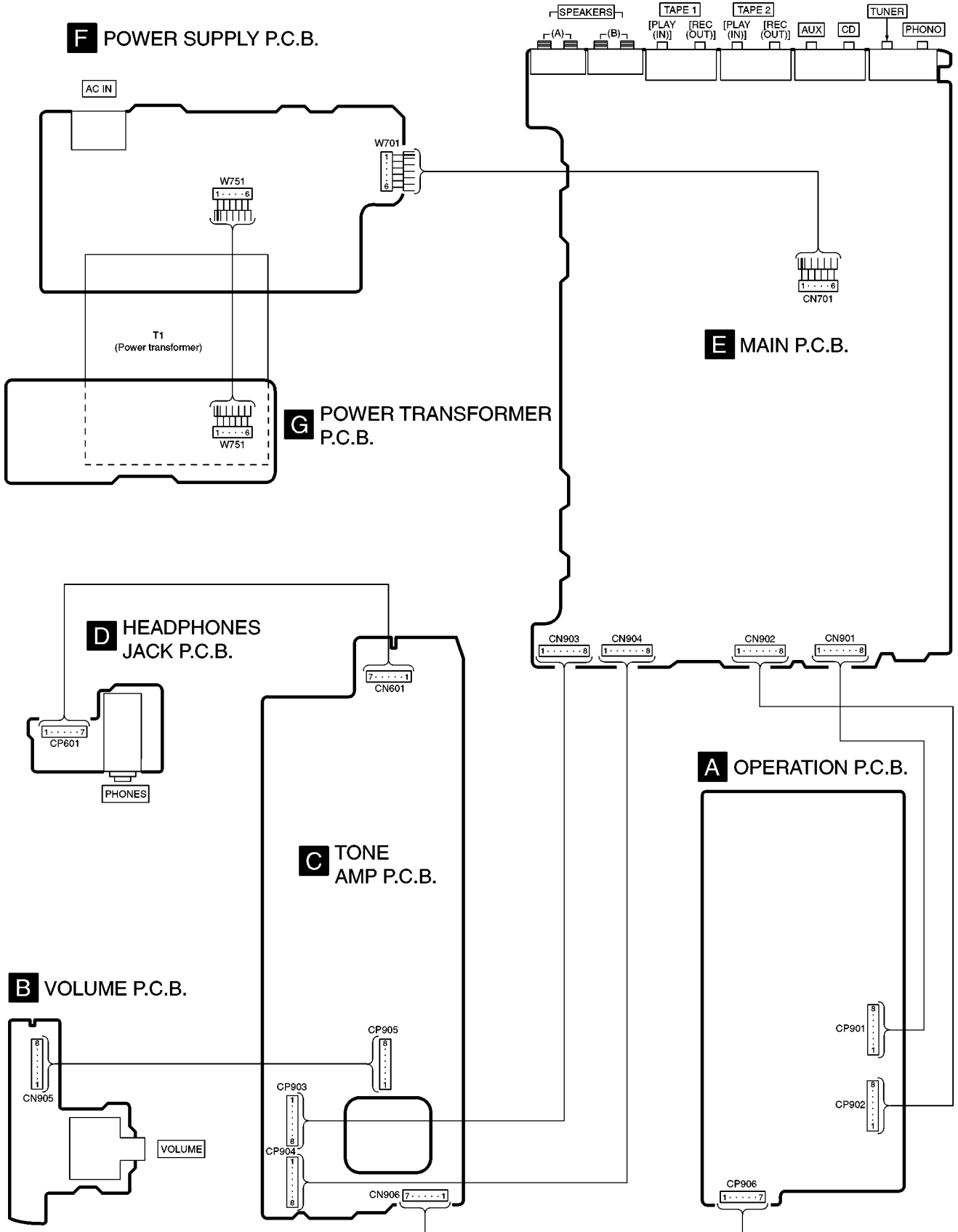

14 Terminal Function of ICs

14.1. IC801 (M37470M2536S): Micro Computer

Pin No.	Terminal Name	I/O	Function
1	P17/SRDY	O	Relay drive signal output
2	P16/CLK	-	Remote control signal output (Not used, open)
3	P15/SOUT	O	LED (PHONO) drive signal output
4	P14/SIN	O	LED (TUNER) drive signal output
5	P13/T1	O	LED (CD) drive signal output
6	P12/T0	O	LED (AUX) drive signal output
7	P11	O	LED (TAPE2) drive signal output
8	P10	O	LED (TAPE1 MONITOR) drive signal output
9	P23/IN3	-	Motor (volume control) drive signal output (Not used, open)
10	P22/IN2		
11	P21/IN1	I	Input selector switch signal input
12	P20/INO	I	Speaker A, B select switch signal input
13	VREF	I	Reference voltage input

Pin No.	Terminal Name	I/O	Function
14	X IN	I	Crystal oscillator connected terminal (F=4 MHz)
15	X OUT	O	
16	V _{SS}	-	GND
17	V _{CC}	I	Power supply terminal
18	RESET	I	System reset signal input
19	P30/INT0	I	Back up detect signal input
20	P31/INT1	-	Not used, connected to GND
21	P32/CNTR0	I	Power switch signal input (Not used, connected to GND)
22	P23/CNTR1	-	Not used, connected to GND
23	P40	O	Strobe signal output for input selector
24	P41	O	Clock signal output for input selector
25	P00	O	Data signal output for input selector
26	P01	O	Speaker A select signal output
27	P02	O	Speaker B select signal output
28	P03	O	LED (SPEAKER A) drive signal output
29	P04	O	LED (SPEAKER B) drive signal output
30	P05	-	Not used, connected to GND
31	P06	-	Not used
32	P07	O	Audio muting control signal output

15 Replacement Parts List

Notes:

- Important safety notice:

Components identified by \triangle mark have special characteristics important for safety.

Furthermore, special parts which have purposes of fire-retardant (resistors), high-quality sound (capacitors), low-noise (resistors), etc. are used.

When replacing any of components, be sure to use only manufacturer's specified parts shown in the parts list.

- The <IA> <IB> <IC> <ID> <IE> marks in Remarks indicate language of instruction manual.

<IA>: English, Spanish, Swedish

<IB>: Russian, Polish, Czech

<IC>: German, Italian, French

<ID>: Netherlands, Danish,

<IE>: English

- The parenthesized indications in the Remarks columns specify the areas. (Refer to the cover page for area.)
- The marking [RTL] indicates that Retention Time is Limited for this item. After the discontinuation of this assembly in production, the item will continue to be available for a specific period of time. The retention period of availability is dependent on the type of assembly, and in accordance with the laws governing part and product retention. After the end of this period, the assembly will no longer be available.

- All parts are supplied by MESA.

Ref. No.	Part No.	Part Name & Description	Pcs	Remarks
1	RHD30035-K1	SCREW	4	
2	RKM0036D-K	TOP CABINET	1	
3	XTBS3+8JFZ1	SCREW	17	
4	RGW0201-K	KNOB, VOLUME	1	
5	RHD30070	SCREW	1	

Ref. No.	Part No.	Part Name & Description	Pcs	Remarks
6	RKA0053-A	FOOT	4	
7	RMG0332-K	RUBBER	2	
8	RGF0389G-K1	FRONT PANEL	1	
9	RGB0031-A	TECHNICS BADGE	1	
10	RGL0184A-Q1	PANEL LIGHT 1	1	
11	RGL0185A-Q	PANEL LIGHT 2	1	
12	RGL0229-Q	PANEL LIGHT 3	1	
13	XTW3+15T	SCREW	2	
14	RGU0887A-K2	BUTTON, SPEAKER	1	
15	RGU0889-K	BUTTON, TONE	1	
16	RGU1038A-K	BUTTON, SELECTOR	1	
17	RGU1685-K	BUTTON, POWER	1	
18	RGW0177A-K	KNOB, TONE	3	
19	RHD26017	SCREW	11	
20	RHD26018	SCREW	1	
21	RHN90001	NUT	4	
22	RMR1181-K	COVER	1	
24	XTB3+20JFZ	SCREW	7	
25	XTB3+8JFZ	SCREW	8	
A1	RJA0019-1X	AC POWER SUPPLY CORD	1	(E, EG) \triangle
A1	RJA0053-2X	AC POWER SUPPLY CORD	1	(EB) \triangle
A3	RQCB0169	SERVICE CENTER LIST	1	
A4	RQT4663-1E	INSTRUCTION MANUAL	1	(E) <IA>
A4	RQT4664-1R	INSTRUCTION MANUAL	1	(E) <IB>
A4	RQT4665-1D	INSTRUCTION MANUAL	1	(EG) <IC>
A4	RQT4666-1H	INSTRUCTION MANUAL	1	(EG) <ID>
A4	RQT4667-1B	INSTRUCTION MANUAL	1	(EB) <IE>
C401	ECEA1VKA4R7B	35V 4.7U	1	
C402, 03	ECBA1E103ZF5	25V 0.01U	2	ECBT1E103ZF5
C404	ECEA1VKA4R7B	35V 4.7U	1	
C405	ECBT1H102KB5	50V 1000P	1	F1D1H102A012
C407-22	ECBT1H101KB5	50V 100P	16	F1D1H101A012
C425-28	ECEA1CKS100	16V 10U	4	
C451, 52	ECEA1VKA4R7B	35V 4.7U	2	
C455, 56	ECBT1H102KB5	50V 1000P	2	F1D1H102A012
C457, 58	RCE1AKA330BG	10V 33U	2	F2A1A330A011
C459, 60	ECQB1H223JF3	50V 0.022U	2	
C461, 62	ECQB1H682JF3	50V 6800P	2	

Ref. No.	Part No.	Part Name & Description	Pcs	Remarks
C463,64	ECEALVKA4R7B	35V 4.7U	2	
C465,66	ECBA1E103ZF5	25V 0.01U	2	ECBT1E103ZF5
C467,68	ECBT1H181KB5	50V 180P	2	
C471,72	RCE1HKA3R3BG	50V 3.3U	2	F2A1H3R3A015
C475,76	ECBT1H101KB5	50V 100P	2	F1D1H101A012
C477,78	ECBT1H221KB5	50V 220P	2	F1D1H221A012
C479,80	ECBT1H560J5	50V 56P	2	ECBT1H560J3
C481,82	ECEALVKA4R7B	35V 4.7U	2	
C483,84	ECEALHKS010	50V 1U	2	
C485,86	ECFR1E123KR	25V 0.012U	2	F1C1E123A005
C487,88	ECQV1H683JZ3	50V 0.068U	2	
C489,90	ECQB1H392JF3	50V 3900P	2	
C491,92	ECFR1E273KR	25V 0.027U	2	F1C1E273A011
C495,96	ECBA1E103ZF5	25V 0.01U	2	ECBT1E103ZF5
C518	ECBA1E103ZF5	25V 0.01U	1	ECBT1E103ZF5
C561,62	ECBT1H102KB5	50V 1000P	2	F1D1H102A012
C601,02	ECEALHKN3R3B	25V 3.3U	2	
C603,04	ECBT1H271KB5	50V 270P	2	F1D1H271A012
C605,06	ECEALCKS220	16V 22U	2	
C607,08	ECCR1H180JC5	50V 18P	2	
C609,10	ECBT1H102KB5	50V 1000P	2	F1D1H102A012
C611-14	ECQV1H104JM3	50V 0.1U	4	
C615	ECEALHN100SB	50V 10U	1	
C616	ECEALHKA330B	50V 33U	1	
C621-24	ECQB1H153JF3	50V 0.015U	4	
C625	ECBT1H271KB5	50V 270P	1	F1D1H271A012
C626	ECEA0JKS101	6.3V 100U	1	
C627	ECBT1E223ZF	25V 0.022U	1	F1D1E223A001
C628	RCE1CKA470BG	16V 47U	1	F2A1C470A017
C629,30	ECQV1H473JM3	50V 0.047U	2	
C702	ECQE2104KF3	250V 0.1U	1	
C703,04	ECEALHU332UE	3300U	2	△
C707,08	ECEALEKA470B	25V 47U	2	
C711	ECBT1H271KB5	50V 270P	1	F1D1H271A012
C753	ECA1HM471	470U	1	△
C756	ECKR1H103ZF5	50V 0.01U	1	F1B1H1030001
C757	RCE1CKA470BG	16V 47U	1	F2A1C470A017
C758	RCE1AKA101BG	10V 100U	1	F2A1A1010020
C759,60	RCE1CM102BV	1000U	2	△
C775	ECBT1C392KR5	16V 3900P	1	F1D1C392A010
C801	ECBT1C103NS5	16V 0.01U	1	
C803	ECBT1C103NS5	16V 0.01U	1	
C804	ECA0JM102	6.3V 1000U	1	
C805	RCE1HKAR47BG	50V 0.47U	1	F2A1HR47A015
C806	ECEALHKS2R2	50V 2.2U	1	
C807	ECEALEKS4R7	25V 4.7U	1	
CN601	RJU057W007	CONNECTOR (7P)	1	K1KB07B00017
CN701	RJS1A6606T1	CONNECTOR (6P)	1	K1MP06A00009
CN751-55	RJS1A1101T1	CONNECTOR (1P)	5	
CN757	SJS305-1	CONNECTOR (3P)	1	(E, EG)
CN757	SJS702-2	CONNECTOR (7P)	1	(EB)
CN901-05	RJU003K008M1	CONNECTOR (8P)	5	K1KB08A000046
CN906	SJS50782JQH	CONNECTOR (7P)	1	K1KB07B000016
CP601	RJT057W007-1	CONNECTOR (7P)	1	K1KA07A00102
CP901-05	RJT003K008-1	CONNECTOR (8P)	5	K1KA08C000002
CP906	SJT30745JQ	CONNECTOR (7P)	1	K1KA07B000053
D601,02	MA165	DIODE	2	MA2C165
D604	MA4160M	DIODE	1	MAZ41600M
D606-08	MA165	DIODE	3	MA2C165
D701-04	P300DLF	DIODE	4	BOEAKM000025 △
D705	MA4150M	DIODE	1	MAZ41500M △
D706	MA4075M	DIODE	1	MAZ40750M △
D707	1SR35200TB	DIODE	1	BOEAKM000076 △
D708	MA167	DIODE	1	MA2C167 △
D710	MA4051M	DIODE	1	MAZ40510M △

Ref. No.	Part No.	Part Name & Description	Pcs	Remarks
D712	MA4075M	DIODE	1	MAZ40750M △
D751,52	1SR35200TB	DIODE	2	BOEAKM000076 △
D753	MA4240H	DIODE	1	MAZ42400H
D754	MA165	DIODE	1	MA2C165
D756	MA4068L	DIODE	1	MAZ40680L △
D801-04	MA165	DIODE	4	MA2C165
D806	MA165	DIODE	1	MA2C165
D807	1SS291TA	DIODE	1	
D808	MA165	DIODE	1	MA2C165
D809-13	LN018304P	LED	5	
D814	LN014304P	LED	1	
D816-19	LN018304P	LED	4	
D820	MA165	DIODE	1	MA2C165
D821	1SS291TA	DIODE	1	
D823-26	MA165	DIODE	4	MA2C165
F1	XBA2C10TB0	FUSE	1	K5D102BL0001 △
FP701	RSFMB05KT-L	FUSE PROTECTOR	1	K5G500A00002 △
IC401	NJU7312AL	IC	1	C0JZAS000001
IC402	MS218AP	IC	1	C0AABB000055
IC451	AN6558F	IC	1	
IC471	UPC4570C	IC	1	
IC601	RSN3502C	IC	1	△
IC801	M37470M2536S	IC	1	C2BADB000023
JK401-04	SJF3069N	JACK, IN/OUT TERMINAL	4	
JK601	RJ63TA01	JACK, HEADPHONES	1	K2HB103J0064
JK601,02	RJR0054	JACK, SPEAKERS	2	K4BC04B00012
JK791	SJS9236-1	JACK, AC IN	1	K2AA2B000002 △
L1	RLQZ271M	COIL	1	ELF18D293DR △
L601,02	SLQY07G-40	COIL	2	G0ZZ00001629
L801	ELEXT101KA9	COIL	1	
P1	RPQ0164	PAD	1	
P2	RPF0139-1	PROTECTION BAG (F.B.)	1	
P3	RPG4289	PACKING CASE	1	(E)
P3	RPG4290	PACKING CASE	1	(EB, EG)
P4	RPN0684-3	CUSHION	1	
P5	SPP756	PROTECTION BAG	1	
P6	RPH0032	SHEET	1	(EB)
PCB1	REP3179A-M	MAIN P.C.B. ASS`Y	1	[RTL]
PCB2	REP3181A-S	P.C.B. ASS`Y	1	[RTL]
PCB3	REP3183A-P	P.C.B. ASS`Y	1	[RTL] (E, EG)
PCB3	REP3183B-P	P.C.B. ASS`Y	1	[RTL] (EB)
Q505-08	2SD1915FTA	TRANSISTOR	4	
Q601-05	2SC3311AR	TRANSISTOR	5	
Q606	2SA1309AR	TRANSISTOR	1	
Q702	2SD2037EFTA	TRANSISTOR	1	△
Q751	2SC2458GR	TRANSISTOR	1	
Q803	UN4211	TRANSISTOR	1	UNR4211
Q804-09	UN4111	TRANSISTOR	6	UNR4111
Q810	UN4211	TRANSISTOR	1	UNR4211
Q812	UN4211	TRANSISTOR	1	UNR4211
Q813,14	UN4111	TRANSISTOR	2	UNR4111
Q815	2SA1309AR	TRANSISTOR	1	
Q816	2SK330GRYTA	TRANSISTOR	1	
Q817	DTA124ESTP	TRANSISTOR	1	B1GCCFLL0003
Q818	2SC3311AR	TRANSISTOR	1	
R401,02	ERDS2FJ102	1/4W 1K	2	
R405-16	ERDS2FJ102	1/4W 1K	12	

Ref. No.	Part No.	Part Name & Description	Pcs	Remarks
R423, 24	ERDS2FJ102	1/4W 1K	2	
R425-27	ERDS2FJ103	1/4W 10K	3	
R429, 30	ERDS2FJ104	1/4W 100K	2	
R431, 32	ERDS2FJ273	1/4W 27K	2	
R449, 50	ERDS2FJ121	1/4W 120	2	
R451, 52	ERDS2FJ224	1/4W 220K	2	
R453, 54	ERDS2FJ102	1/4W 1K	2	
R455, 56	ERDS2FJ563	1/4W 56K	2	
R457, 58	ERDS2FJ271	1/4W 270	2	
R459, 60	ERDS2FJ680	1/4W 68	2	
R461, 62	ERDS2FJ184	1/4W 180K	2	
R463, 64	ERDS2FJ123	1/4W 12K	2	
R465, 66	ERDS2FJ563	1/4W 56K	2	
R467, 68	ERDS2FJ102	1/4W 1K	2	
R475, 76	ERDS2FJ471	1/4W 470	2	
R477, 78	ERDS2FJ104	1/4W 100K	2	
R479, 80	ERDS2FJ474	1/4W 470K	2	
R485, 86	ERDS2FJ223	1/4W 22K	2	
R487-90	ERDS2FJ392	1/4W 3.9K	4	
R491, 92	ERDS2FJ102	1/4W 1K	2	
R493, 94	ERDS2FJ563	1/4W 56K	2	
R495, 96	ERDS2FJ223	1/4W 22K	2	
R497, 98	ERDS2FJ392	1/4W 3.9K	2	
R501, 02	ERDS2FJ222	1/4W 2.2K	2	
R509, 10	ERDS2FJ222	1/4W 2.2K	2	
R525, 26	ERDS2FJ102	1/4W 1K	2	
R528	ERDS2FJ394	1/4W 390K	1	
R532	ERDS2FJ103	1/4W 10K	1	
R533, 34	ERDS2FJ102	1/4W 1K	2	
R601, 02	ERDS2FJ182	1/4W 1.8K	2	
R603, 04	ERDS2FJ563	1/4W 56K	2	
R605, 06	ERDS2FJ272	1/4W 2.7K	2	
R607, 08	ERDS2FJ563	1/4W 56K	2	
R609, 10	ERDS2FJ470	1/4W 47	2	
R611, 12	ERDS1FJ100	10	2	△
R619	ERDS2FJ124	1/4W 120K	1	
R620	ERDS2FJ682	1/4W 6.8K	1	
R623	ERDS2FJ684	1/4W 680K	1	
R625	ERDS1FJ272	2.7K	1	△
R627-30	ERGLS151	1W 150	4	
R633, 34	ERDS2FJ103	1/4W 10K	2	
R635, 36	ERDS2FJ222	1/4W 2.2K	2	
R639, 40	ERDS2FJ474	1/4W 470K	2	
R643, 44	ERDS2FJ470	1/4W 47	2	
R645-48	ERDS1FJ331	330	4	△
R649	ERDS2FJ823	1/4W 82K	1	
R650	ERDS2FJ124	1/4W 120K	1	
R651	ERDS2FJ563	1/4W 56K	1	
R652	ERDS2FJ564	1/4W 560K	1	
R653	ERDS2FJ223	1/4W 22K	1	
R654	ERDS2FJ103	1/4W 10K	1	
R656, 57	ERDS1FJ100	10	2	△
R658	ERDS2FJ182	1/4W 1.8K	1	
R707, 08	ERDS1FJ561	560	2	△
R722-24	ERDS1FJ271	270	3	△
R725	ERDS2FJ153	1/4W 15K	1	
R751	ERDS2FJ122	1/4W 1.2K	1	
R752	ERDS2FJ472	1/4W 4.7K	1	
R753, 54	ERGLS331	1W 330	2	
R756	ERDS2FJ102	1/4W 1K	1	
R757, 58	ERDS1FJ688	6.8	2	△
R801	ERDS2FJ103	1/4W 10K	1	
R803	ERDS2FJ103	1/4W 10K	1	
R805, 06	ERDS2FJ103	1/4W 10K	2	
R807	ERDS2FJ104	1/4W 100K	1	
R808-10	ERDS2FJ103	1/4W 10K	3	
R811	ERDS2FJ821	1/4W 820	1	
R812	ERDS2FJ102	1/4W 1K	1	
R813	ERDS2FJ122	1/4W 1.2K	1	
R814	ERDS2FJ152	1/4W 1.5K	1	
R815	ERDS2FJ182	1/4W 1.8K	1	
R817	ERDS2FJ221	1/4W 220	1	
R818-20	ERDS2FJ561	1/4W 560	3	

Ref. No.	Part No.	Part Name & Description	Pcs	Remarks
R822	ERDS2FJ821	1/4W 820	1	
R823	ERDS2FJ102	1/4W 1K	1	
R825	ERDS2FJ473	1/4W 47K	1	
R826	ERDS2FJ181	1/4W 180	1	
R827	ERDS2FJ331	1/4W 330	1	
R828	ERDS2FJ102	1/4W 1K	1	
R829	ERDS2FJ103	1/4W 10K	1	
R830	ERDS2FJ472	1/4W 4.7K	1	
R831	ERDS2FJ331	1/4W 330	1	
R832	ERDS2FJ105	1/4W 1M	1	
R833	ERDS2FJ334	1/4W 330K	1	
R834	ERDS2FJ103	1/4W 10K	1	
RL601, 02	RSY0013-0	RELAY	2	△
RL751	RSY0015M-0	RELAY	1	△
S401	ESB68047	SW, TONE	1	
S801-06	EVQ21405R	SW, PUSH	6	EVQ21405RJ
S807	RSP2B026-A	SW, PUSH	1	K0F122A00139
S808, 09	EVQ21405R	SW, SPEAKER A/B	2	EVQ21405RJ
T1	RTP2M5B005	POWER TRANSFORMER	1	ETP68VRU71EA (EB) △
T1	RTP2M5E001	POWER TRANSFORMER	1	ETP68VRU61DA (E, EG) △
VR471, 72	EVJYA1F04C15	VR, BASS/TREBLE	2	
VR501	RRV16B05B15A	VR, VOLUME	1	D2BHD15Y0002
VR502	EVJ02QF04G15	VR, BALANCE	1	
X801	EF0EC4004T4	OSCILLATOR	1	EFOEC4004T4

16 Cabinet Parts Location

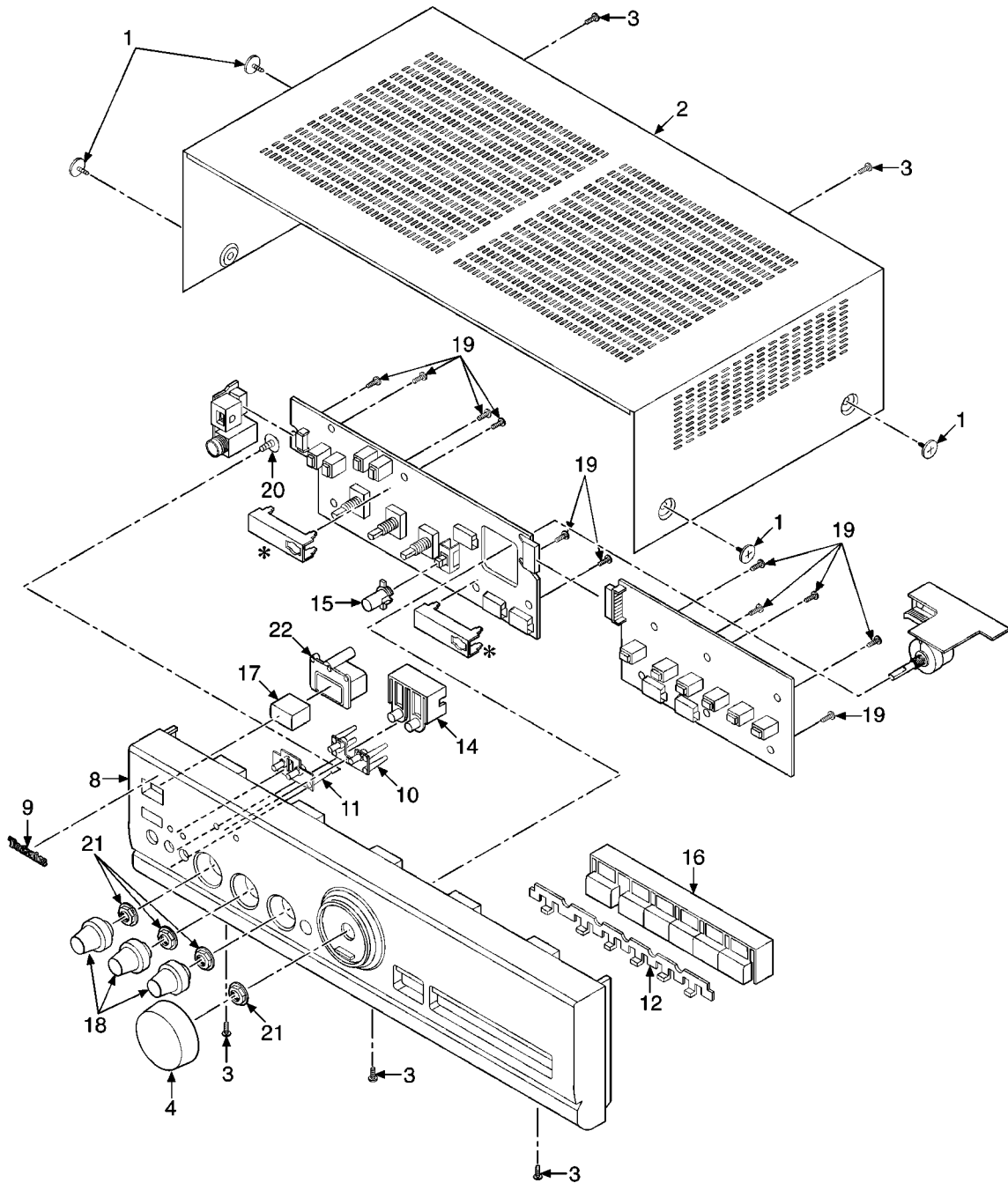

Note : We do not supply those items of parts marked * .

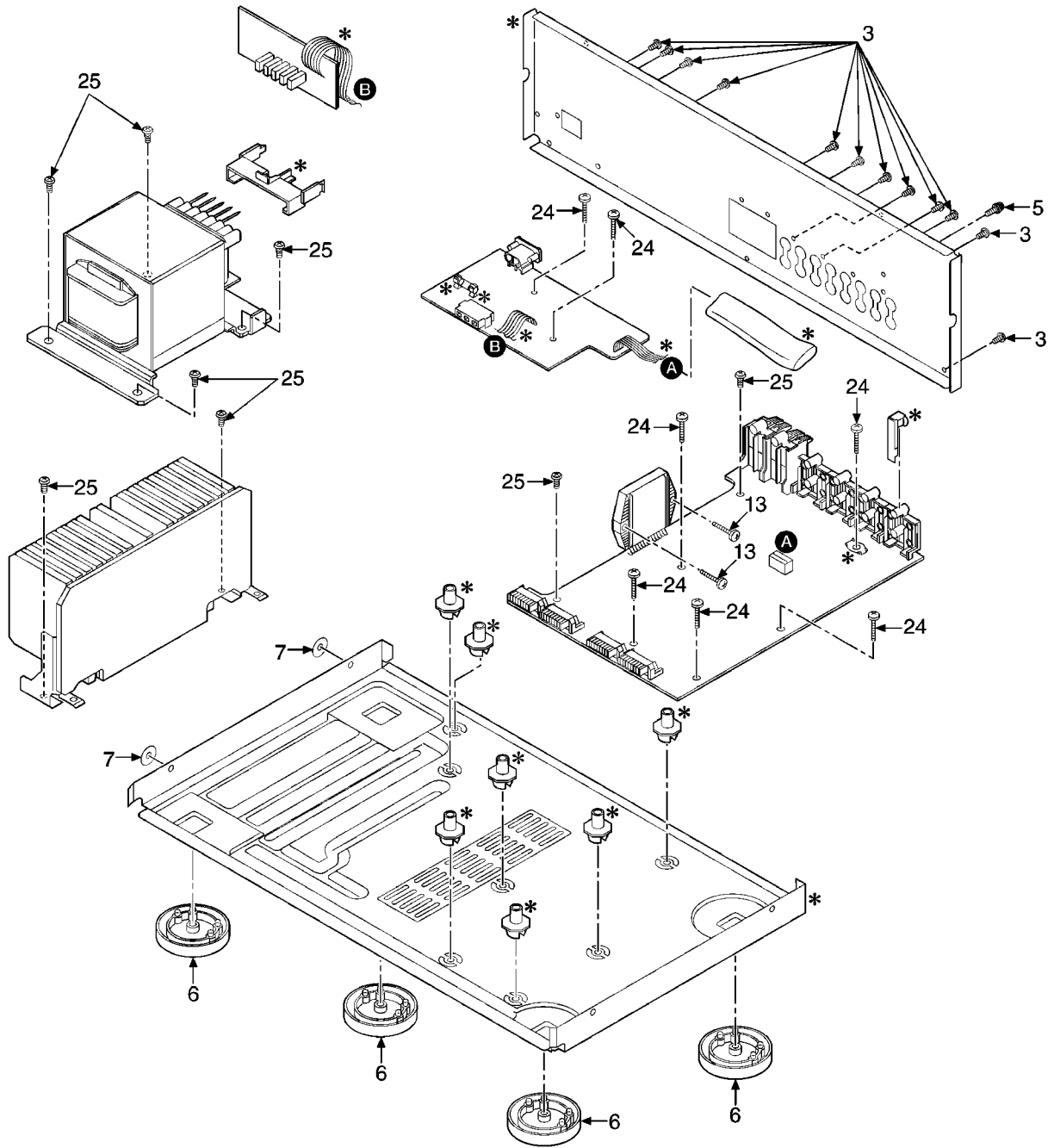

Note : We do not supply those items of parts marked * .

17 Packaging

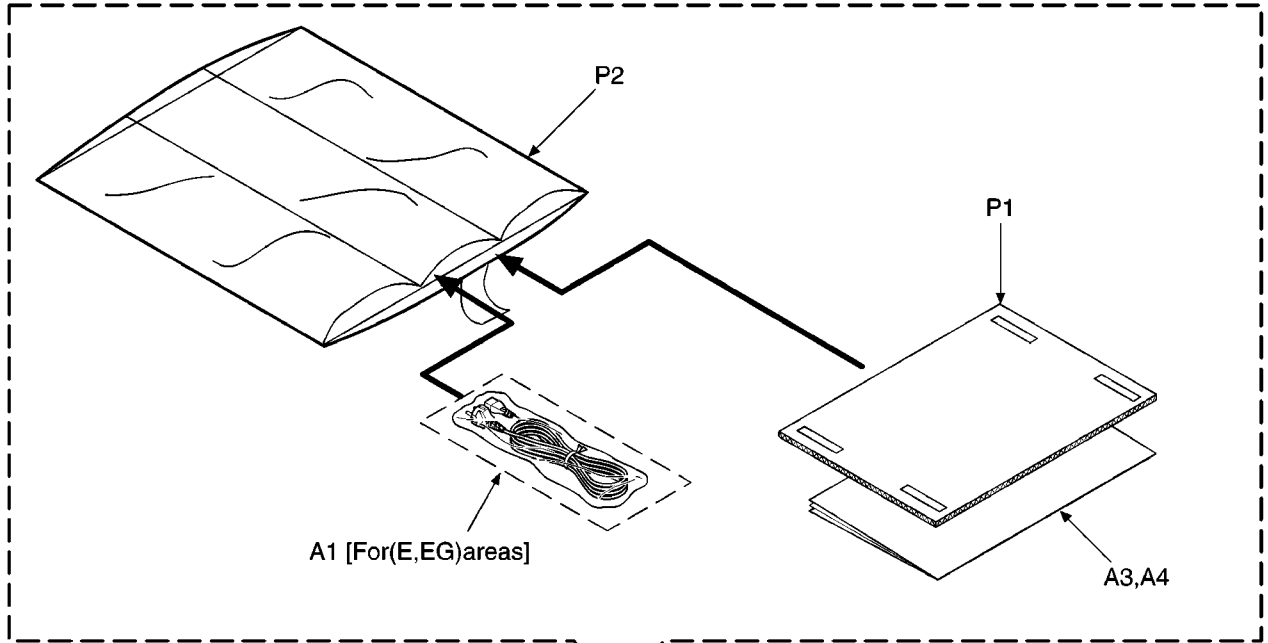

[For(EB)area]

