

Service Manual

Stereo Integrated Amplifier

Amplifier

SU-V500

Colour

(K) Black Type



Specifications (DIN 45 500)

20 Hz – 20 kHz continuous power output both channels driven	2 × 30 W (8 Ω)
40 Hz – 20 kHz continuous power output both channels driven	2 × 27 W (8 Ω)
For (GC) area only	2 × 38 W (8 Ω)
1 kHz continuous power output both channels driven (THD: 1%)	2 × 50 W (4 Ω)
For (GC) area only	2 × 33 W (8 Ω)
	2 × 40 W (4 Ω)
63 Hz – 12.5 kHz continuous power output both channels driven (THD: 1%)	2 × 35 W (8 Ω)
For (GC) area only	2 × 45 W (4 Ω)
	2 × 30 W (8 Ω)
	2 × 35 W (4 Ω)
Total harmonic distortion rated power at 20 Hz – 20 kHz	0.1% (8 Ω)
Intermodulation distortion (50 Hz: 7 kHz = 4:1, SMPTE) rated power	0.1% (8 Ω)
Residual hum and noise	1 mV
Damping factor	60 (8 Ω)
	30 (4 Ω)
Headphones output level/impedance	340 mV/47 Ω
Load impedance	
A or B	4 – 16 Ω
A and B	8 – 16 Ω
Input sensitivity/impedance	
PHONO MM	2.5 mV/47 kΩ
TUNER, CD, AUX, TAPE 1, TAPE 2/DCC	150 mV/22 kΩ
Phono maximum input voltage (1 kHz, RMS)	
MM	150 mV (IHF '66)
S/N (rated power, 4Ω)	
PHONO MM	76 dB (77 dB, IHF '66)
For (GC) area only	76 dB (76 dB, IHF '66)
TUNER, CD, AUX, TAPE 1, TAPE 2/DCC	
For (GC) area only	90 dB (95 dB, IHF '66)
S/N at –26 dB power (4 Ω)	
PHONO MM	67 dB
TUNER, CD, AUX, TAPE 1, TAPE 2/DCC	70 dB
S/N at 50 mW power (4 Ω)	
PHONO MM	63 dB
TUNER, CD, AUX, TAPE 1, TAPE 2/DCC	63 dB

Areas

Suffix for Model No.	Area	Colour
(E)	Europe	(K)
(EB)	Great Britain	
(EG)	Germany and Italy	
(EO)	Switzerland	
(GC)	Asia, Latin America, Middle Near East and Africa	
(GN)	Oceania	

Frequency response

PHONO MM

RIAA standard curve ±1 dB
(30 Hz – 15 kHz)

TUNER, CD, AUX, TAPE 1, TAPE 2/DCC

3 Hz – 80 kHz (+0, –3 dB)
+0 dB, –0.3 dB (20 Hz – 20 kHz)

Tone controls

BASS

50 Hz, +10 to –10 dB

TREBLE

20 kHz, +10 to –10 dB

Output voltage

TAPE 1, TAPE 2/DCC REC OUT

150 mV

Channel balance (AUX 250 Hz – 6.3 kHz)

±1 dB

Channel separation (AUX 1 kHz)

50 dB

GENERAL

Power consumption

130 W

Power supply

For (E), (EG), and (EO) area

50 Hz/60 Hz AC, 230 V

For (EB), (GN) areas

50 Hz/60 Hz AC, 230 V – 240 V

For (GC) area only

50 Hz/60 Hz AC, 110 V – 127 V / 220 V – 240V

Dimensions (W × H × D)

430 × 125 × 310 mm

Weight

6.0 kg

For (GC) area only

5.4 kg

Notes:

- Specifications are subject to change without notice.
Weight and dimensions are approximate.
- Total harmonic distortion is measured by the digital spectrum analyzer.
- For areas except Europe
The specification values given have been measured while using a 240 V power supply.

For (EB) area only

This apparatus was produced to BS 800.

Technics

■ Contents

	Page		Page
● Before Repair	2	● Block Diagram	14
● Protection Circuitry	2	● Schematic Diagram	15~20
● Accessories	2	● Wiring Connection Diagram	21
● Caution for Mains Lead	3	● Printed Circuit Board Diagram	22~27
● Front Panel Controls	4	● Function of IC Terminals	28
● Connections	5, 6	● Replacement Parts List	29~35
● Listening to Sound	7, 8	● Packaging	32
● Recording	9	● Cabinet Parts Location	33, 34
● Operation Check and Main Component Replacement Procedures	10~13		

■ Before Repair

- (1) Turn off the power supply. Using a 10 Ω, 10 W resistor, connect both ends of power supply capacitors (C701, C702) in order to discharge the voltage.
- (2) Before turning the power supply on, after completion of repair, slowly apply the primary voltage by using a power supply voltage controller to make sure that the consumed current at 50/60 Hz in NO SIGNAL mode should be shown below with respect to supply voltage 110 V/127 V/220 V/240 V.

Power supply voltage	AC 230 V	AC 240 V	AC 110~127 V	AC 220~240 V
Consumed current 50Hz	47~157 mA	45~150 mA	80~300 mA	45~150 mA

■ Protection circuitry

The protection circuitry may have operated if either of the following conditions is noticed:

- * No sound is heard when the power is switched ON.
- * Sound stops during a performance.

The functions of this circuitry is to prevent circuitry damage if, for example, the positive and negative speaker connection wires are "shorted", or if speaker systems with an impedance less than the indicated rated impedance of this unit are used.

If this occurs, follow the procedure outlined below:

1. Switch OFF the power.
2. Determine the cause of the problem and correct it.
3. Switch ON the power once again.

Note:

When the protection circuitry functions, the unit will not operate unless the power is first switched OFF and then ON again.

For areas except (E) (EB) (EG) (EO) (GN)

CAUTION:

The AC voltage differs according to the area.
Be sure to set the proper voltage in your area before use.
(For details, please refer to page 6.)

■ Accessories

- AC power supply cord

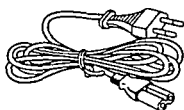

for (E), (EG), (EO), (GC) areas : (RJA0019-2K)

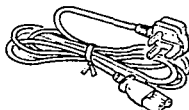

for (EB) area : (VJA0733)

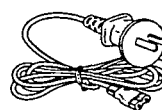

for (GN) area : (RJA0036-K)

- Remote control transmitter
(RAK-SU129WH)

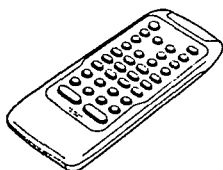

- Batteries
(UM-4, "AAA", R03)



Note: These are available on sales route.

- Power plug adaptor
(SJP5213-2)



for (GC) area only



■ Caution for AC Mains Lead (For United Kingdom)

("EB" area code model only)

For your safety, please read the following text carefully.

This appliance is supplied with a moulded three pin mains plug for your safety and convenience.

A 5-ampere fuse is fitted in this plug.

Should the fuse need to be replaced please ensure that the replacement fuse has a rating of 5-ampere and that it is approved by ASTA or BSI to BS1362. Check for the ASTA mark  or the BSI mark  on the body of the fuse.

If the plug contains a removable fuse cover you must ensure that it is refitted when the fuse is replaced.

If you lose the fuse cover the plug must not be used until a replacement cover is obtained.

A replacement fuse cover can be purchased from your local dealer.

CAUTION!

IF THE FITTED MOULDED PLUG IS UNSUITABLE FOR THE SOCKET OUTLET IN YOUR HOME THEN THE FUSE SHOULD BE REMOVED AND THE PLUG CUT OFF AND DISPOSED OF SAFELY.

THERE IS A DANGER OF SEVERE ELECTRICAL SHOCK IF THE CUT OFF PLUG IS INSERTED INTO ANY 13-AMPERE SOCKET.

If a new plug is to be fitted please observe the wiring code as shown below.

If in any doubt please consult a qualified electrician.

IMPORTANT

The wires in this mains lead are coloured in accordance with the following code:

Blue: Neutral

Brown: Live

As the colours of the wires in the mains lead of this appliance may not correspond with the coloured markings identifying the terminals in your plug, proceed as follows:

The wire which is coloured BLUE must be connected to the terminal in the plug which is marked with the letter N or coloured BLACK.

The wire which is coloured BROWN must be connected to the terminal in the plug which is marked with the letter L or coloured RED.

Under no circumstances should either of these wires be connected to the earth terminal of the three pin plug, marked with the letter E or the Earth Symbol .

Before use

Remove the connector cover as follows.

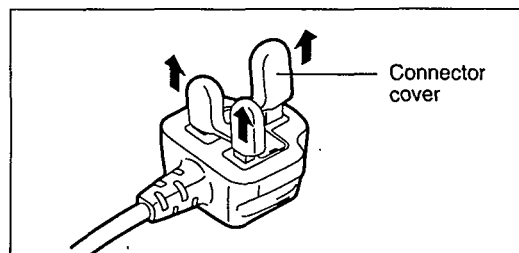

How to replace the fuse

1. Remove the fuse cover with a screwdriver.

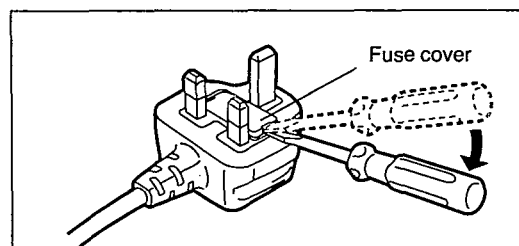

2. Replace the fuse and attach the fuse cover.

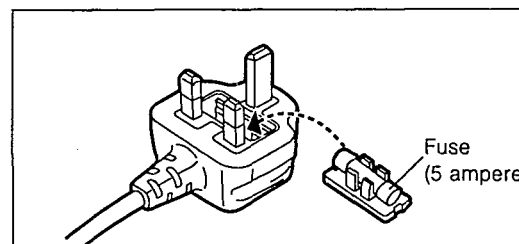

■ Front Panel Controls

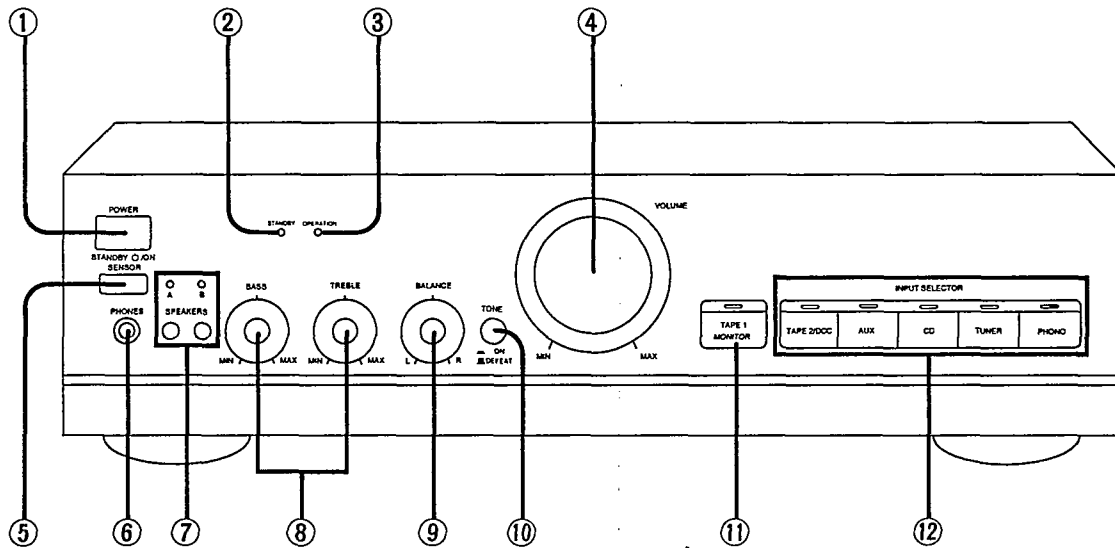

No.	Name
①	Power "STANDBY ON" switch (POWER, STANDBY ON) Press to switch the unit from on to standby mode or vice versa. In standby mode, the unit is still consuming a small amount of power.
②	"STANDBY" indicator (STANDBY) When the unit is connected to the AC mains supply, this indicator lights up in standby mode and goes out when the unit is turned on.
③	Operation indicator (OPERATION) When the power is switched ON, this indicator illuminates after about 2 seconds when the unit is in the operating condition. If an abnormal condition in the circuitry is detected, such as a short-circuit of the positive (+) and negative (-) wires from the speaker terminals, the protection circuit functions and this indicator will not illuminate.
④	Volume control (VOLUME)
⑤	Remote control signal receptor (SENSOR) Receives the signals from the remote control.
⑥	Headphones jack (PHONES)

No.	Name
⑦	Speaker select buttons/indicators (SPEAKERS)
⑧	Tone controls (BASS/TREBLE)
⑨	Balance control (BALANCE)
⑩	Tone control button (TONE)
⑪	TAPE 1 MONITOR button/indicator (TAPE 1 MONITOR)
⑫	Input select buttons/indicators (INPUT SELECTOR)

■ Connections

To connect to each terminal

Make connections to each component in the system by using stereo connection cables (not included).

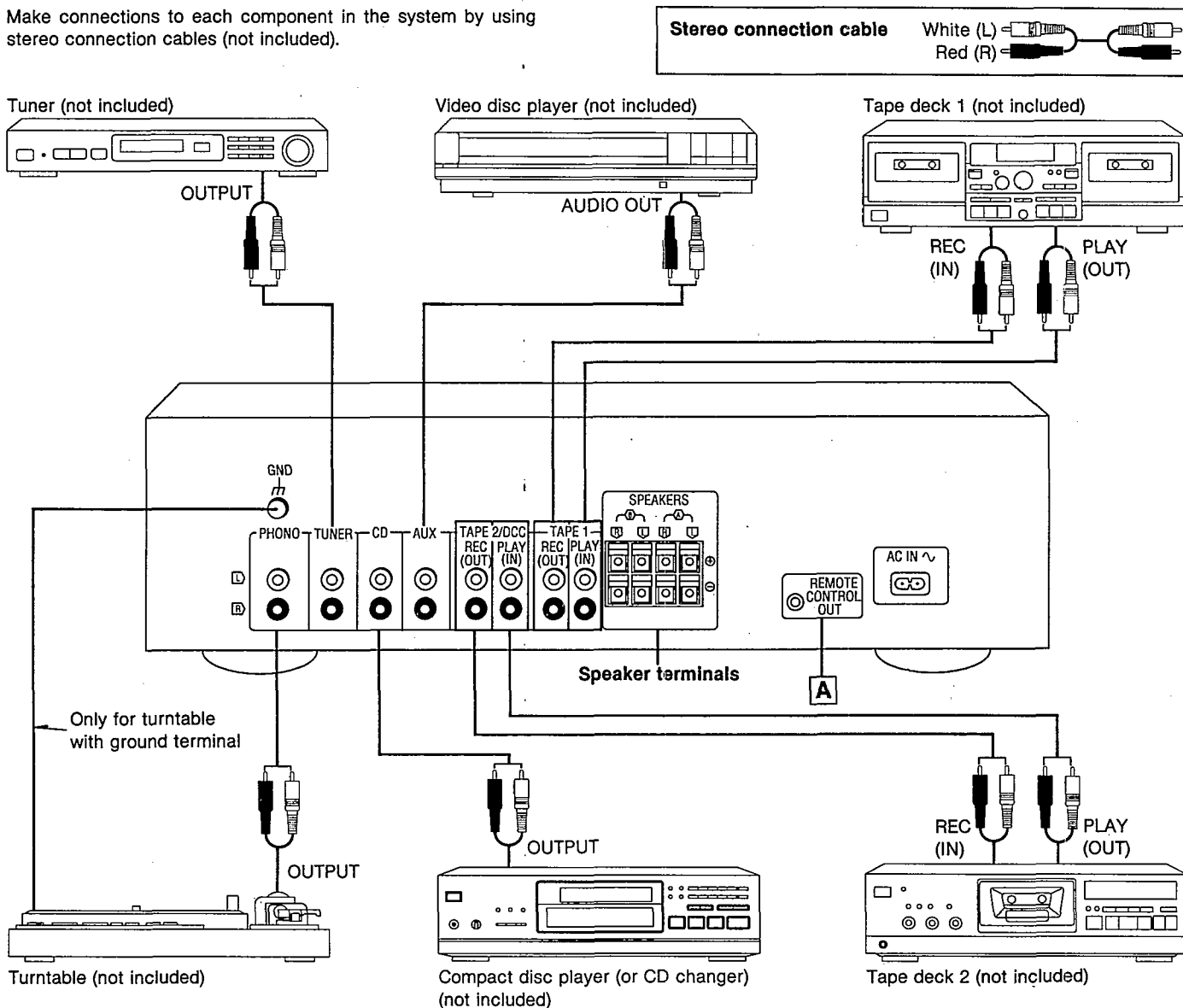

A "REMOTE CONTROL OUT" terminal

Connect the connection cable for the remote control to a Technics tape deck and/or CD player (or CD changer) which has the appropriate remote control terminal as shown at the right.

If a tape deck is not being used, the CD player (or CD changer) can be connected directly (dotted line).

Note

For a tape deck and/or CD player (or CD changer) with a remote control sensor, this connection is not necessary.

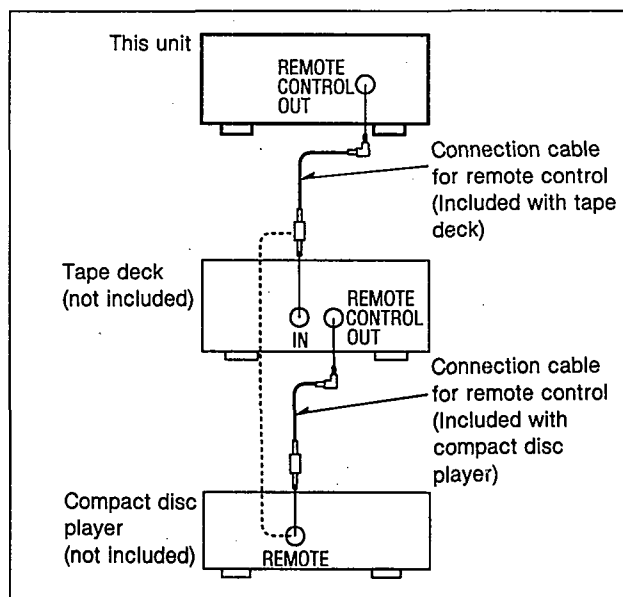

To connect the speakers

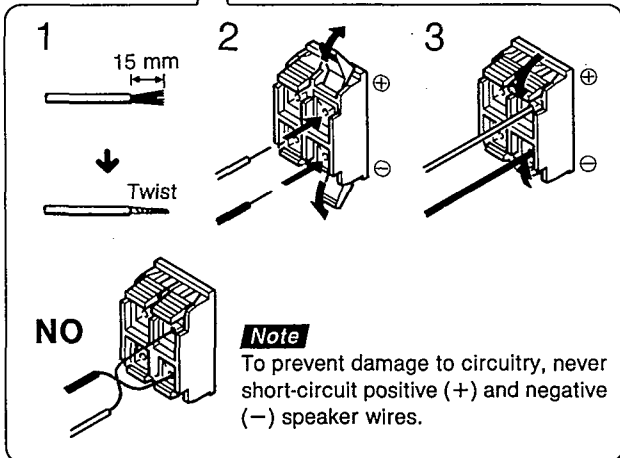
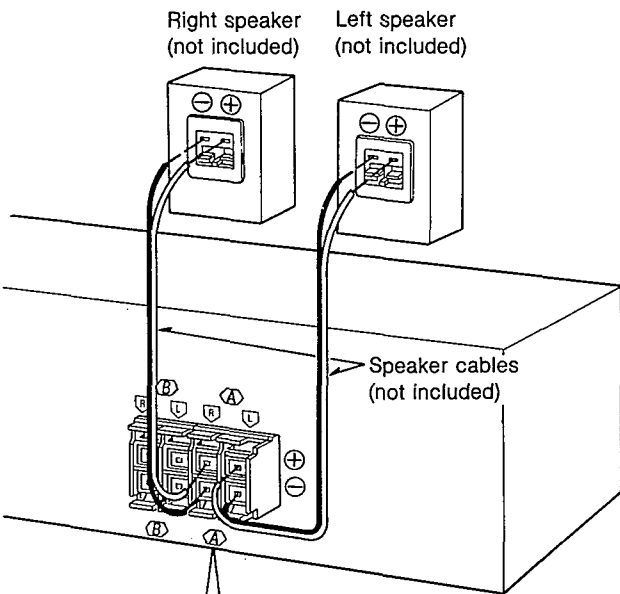

■ "B" terminals

For connection to a second pair of speakers.

■ Speaker impedance

- When only the "A" or only the "B" terminals are used: 4–16 ohms
- When both the "A" and the "B" terminals are used simultaneously: 8–16 ohms

About the cooling fan

The cooling fan operates at high power output levels only. (There is no cooling fan for some countries.)

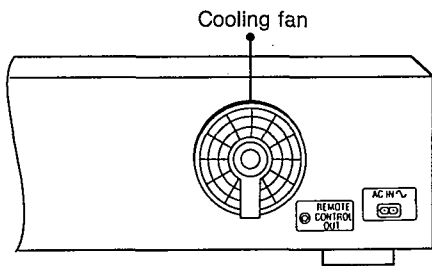

To connect the AC power supply cord

FOR UNITED KINGDOM ONLY
BE SURE TO READ THE CAUTION FOR THE AC POWER SUPPLY CORD ON PAGE 3 BEFORE CONNECTING THE AC POWER SUPPLY CORD.

For areas except United Kingdom, Europe, Australia and N.Z.

Be sure to set the voltage selector to "110 V–127 V" or "220 V–240 V" according to the area in which the unit will be used.

[Use a minus (-) screwdriver]

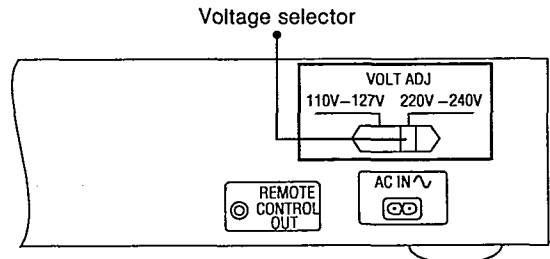

Note

Note that this unit will be seriously damaged if this setting is not made correctly.

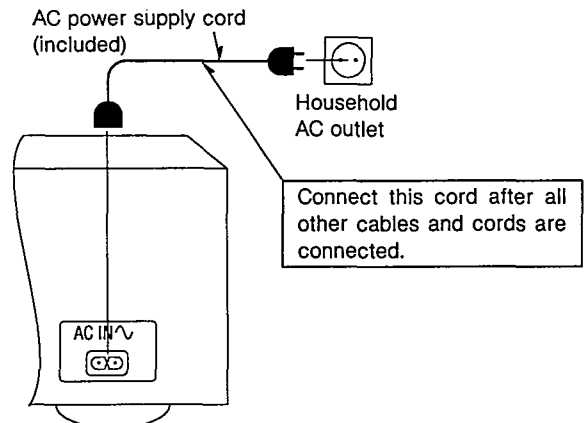

(For areas except Australia and N.Z.)

Insertion of Connector

Even when the connector is perfectly inserted, depending on the type of inlet used, the front part of the connector may jut out as shown in the drawing. However there is no problem using the unit.

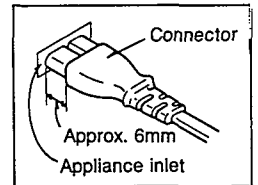

Note

The configuration of the AC power supply cord differs according to area.

Not supplied for United Kingdom, Europe, Australia and N.Z.

If the power plug will not fit your socket, use the power plug adaptor (included).

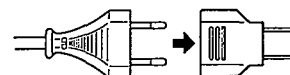

■ Listening to Sound

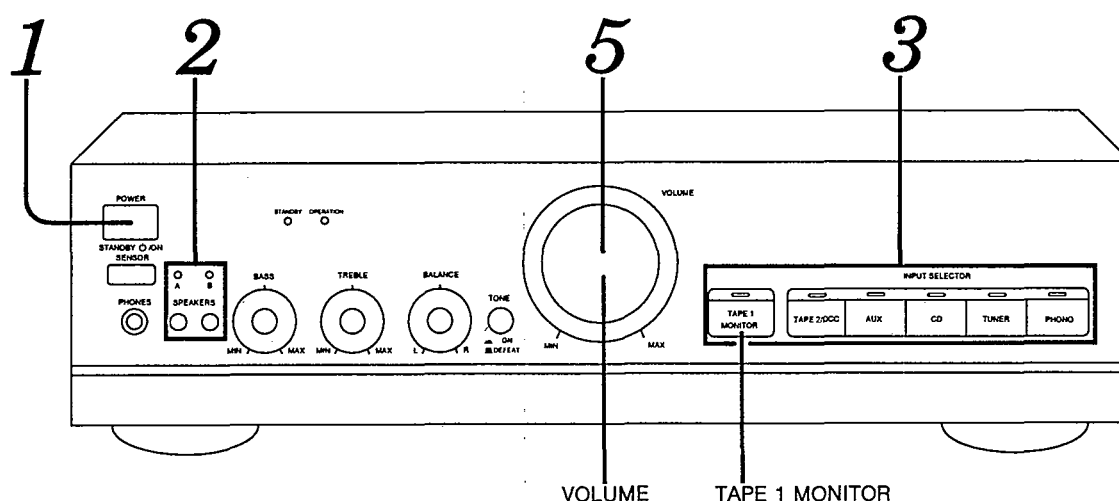

Before operation, set VOLUME to the "MIN" position.

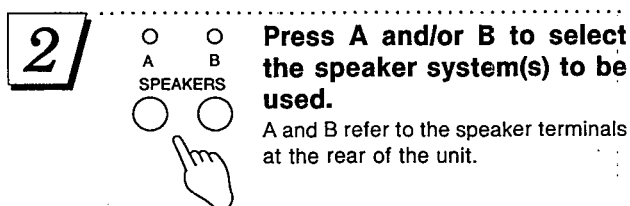
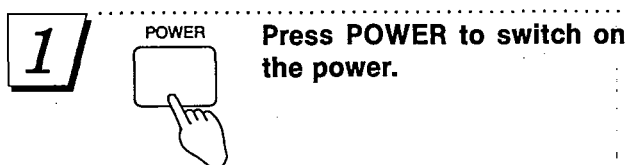

The corresponding indicator above will illuminate to indicate which speaker system is selected.

A: Sound can be heard from the speakers connected to the "A" terminals.

B: Sound can be heard from the speakers connected to the "B" terminals.

A and B: Sound can be heard simultaneously from the speakers connected to the "A" terminals and the "B" terminals.

off: No sound will be heard from the speakers. (Both indicators will turn off.)

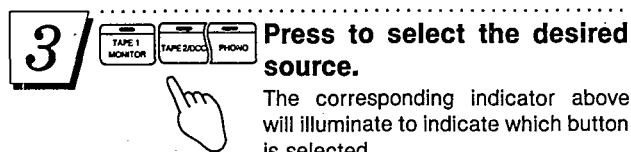

The corresponding indicator above will illuminate to indicate which button is selected.

TAPE 1 MONITOR: To listen to tape (TAPE 1). The tape monitor indicator will illuminate. (See below.)

TAPE 2/DCC: To listen to tape (TAPE 2) or digital compact cassette (DCC).

AUX: To listen to equipment connected to the "AUX" terminals.

CD: To listen to compact discs.

TUNER: To listen to radio broadcasts.

PHONO: To listen to phono discs.

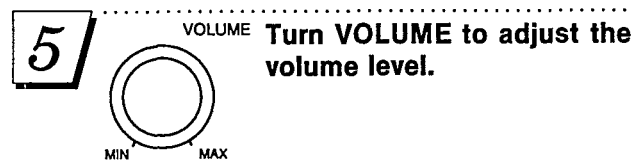
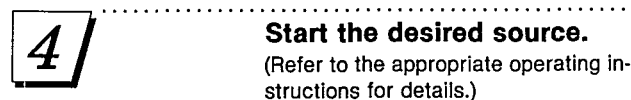

After listening is finished

Be sure to reduce the volume level, and turn the unit off by pressing **POWER**.

When tape 1 monitor indicator illuminates

Illuminates



This indicates that the tape monitor function of this unit is ON.

To listen to sources other than a tape (TAPE 1), be sure to turn off the indicator by pressing **TAPE 1 MONITOR**.

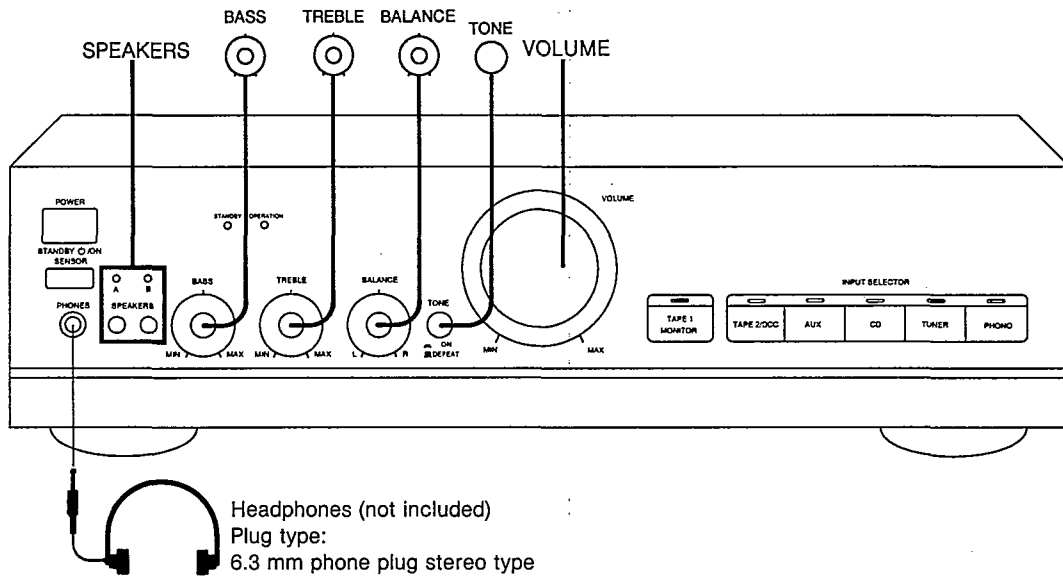

Headphones (not included)
 Plug type:
 6.3 mm phone plug stereo type

To adjust the tone quality



Set **TONE** to the "ON" position.
 If set to the "DEFEAT" position, tone controls have no effect.

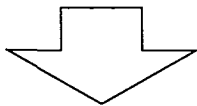

BASS

Turn **BASS** to adjust the low-frequency sound.

TREBLE

Turn **TREBLE** to adjust the high-frequency sound.

To adjust the sound balance



Turn **BALANCE** to adjust the left/right sound balance.

When listening through headphones

Use **VOLUME** to reduce the volume level, and connect the headphones.

If sound from speakers is not wanted, press **SPEAKERS** (A) and/or (B) to turn off the speaker select indicators.

Note
 Avoid listening for prolonged periods of time to prevent hearing damage.

■ Recording

To record from compact discs, etc.

It is possible to record from units which are connected to the rear "AUX", "CD", "TUNER" or "PHONO" terminals to cassette tape decks or DCC decks which are connected to the "TAPE 1" or "TAPE 2/DCC" terminals.

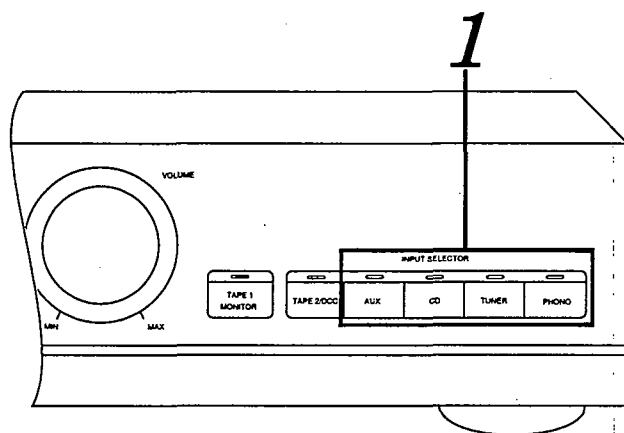

Before recording, prepare the tape deck or DCC for recording (recording level adjustment, etc.).

See the tape deck's or DCC's operating instructions for details.

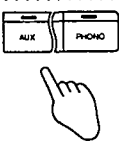
- 1**  **Select the program source to be recorded.**
- AUX:** To record from equipment connected to the "AUX" terminals.
CD: To record from compact discs.
TUNER: To record from radio broadcasts.
PHONO: To record from phono discs.

- 2** **Begin recording.**
 Follow your tape deck's or DCC's operating instructions.

- 3** **Begin the source to be recorded.**

Note

If recording to both decks simultaneously, do not press TAPE 1 MONITOR. (If this button is pressed, it will not be possible to record to the deck which is connected to the "TAPE 2/DCC" terminals.)

To check the sound recorded while recording is being made

If a cassette tape deck with 3 heads is connected to the "TAPE 1" terminals, it is possible to check the sound being recorded on to the tape.

Tape-to-tape recording

It is possible to record from tape deck 2 (the cassette tape deck or DCC deck which is connected to the "TAPE 2/DCC" terminals) to tape deck 1 (the cassette tape deck which is connected to the "TAPE 1" terminals).

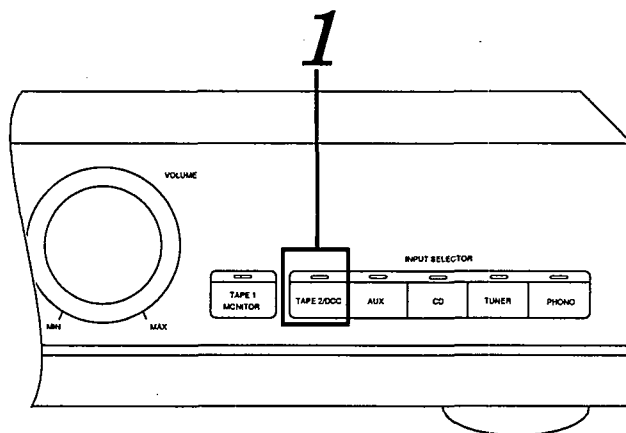

Preparation

- Before recording, prepare the tape deck for recording (recording level adjustment, etc.). See the tape deck's operating instructions for details.
- Load tapes which have been advanced to the end of the leader tape into both decks.

Tape deck 1: For recording **Tape deck 2:** For playback.

- 1**  **Press TAPE 2/DCC.**

- 2** **Begin recording on tape deck 1.**
 Follow your tape deck's operating instructions.

- 3** **Begin tape playback on tape deck 2.**

For your reference

When recording from tape deck 1 to tape deck 2, press TAPE 1 MONITOR in step 1 above, and then start recording on tape 2 and begin playback on tape 1.

At this time, make sure that the input selector is set to a position other than "TAPE 2/DCC". (This is because monitoring of the unit connected to the "TAPE 2/DCC" terminals is not possible.)

-  Press TAPE 1 MONITOR (indicator will illuminate.) on this unit and set the monitor button on the tape deck to "TAPE".

Press TAPE 1 MONITOR once again to turn it off.

■ Operation Checks and Main Component Replacement Procedures

NOTE

1. This section describes procedures for checking the operation of the major printed circuit boards and replacing the main components.
2. For reassembly after operation checks or replacement, reverse the respective procedures. Special reassembly procedures are described only when required.
3. Select items from the following index when checks or replacement are required.

● Contents

	page.
1. Checking for the Volume P.C.B. /Operation P.C.B. /Tone AMP P.C.B.	11.
2. Checking for the Main P.C.B.	12.
3. Replacement for power IC.	13.

1. Common disassembly procedures (Follow this procedure prior to other disassembly.)

- NOTE**
1. Illustrated screws are equivalent to actual size.
 2. [] indicates parts No.

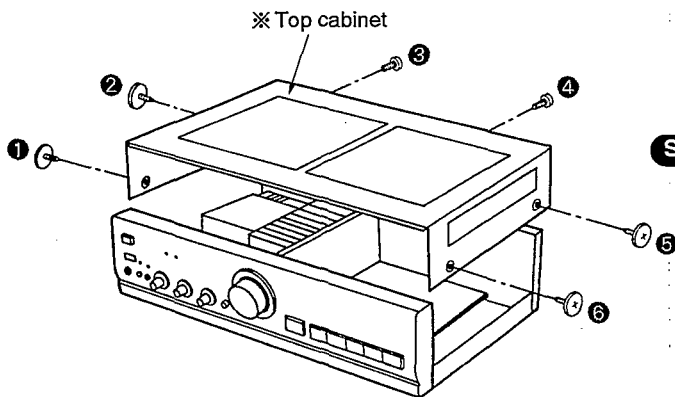

Step 1 Remove the 6 screws.

- ※ RKM0036E-K(EB,EO,GC)
- ※ RKM0036D-K(E,EG,GN)

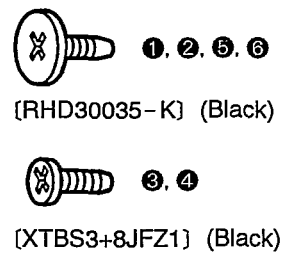

2. Checking for the Volume P.C.B. /Operation P.C.B. /Tone AMP P.C.B.

Step 1 Follow the disassembly procedure described in item 1 on page 10.

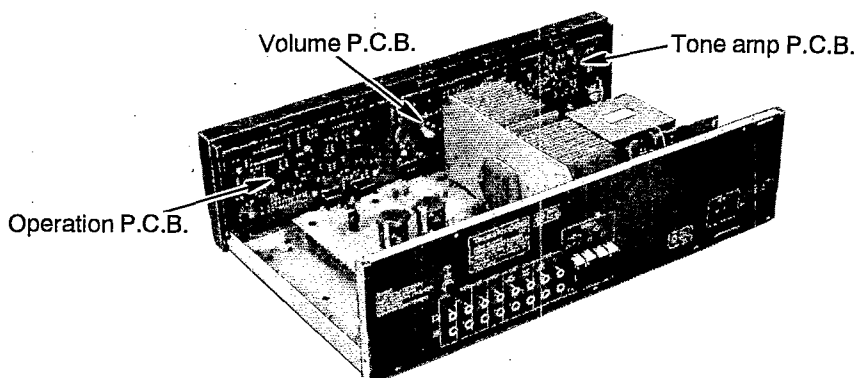

Step 2 Remove the 3 screws.

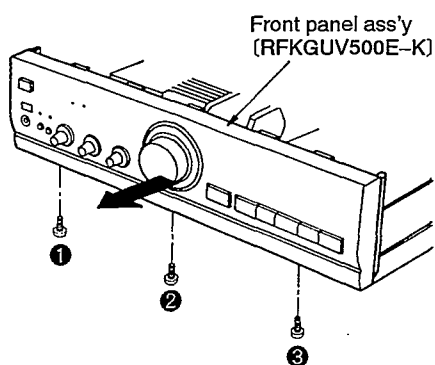

Step 3 Remove the knob and nut.

Step 4 Remove the volume P.C.B.

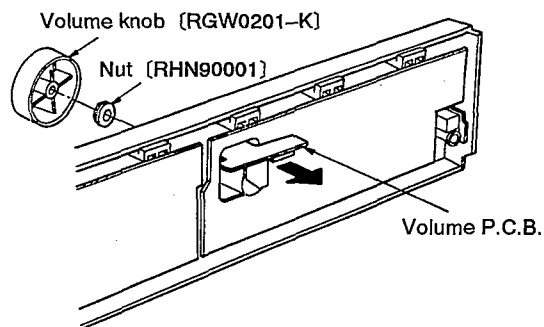

Step 5 Remove the knobs and nuts.

Remove the knob with pushing by ⊖ screwdriver toward the P.C.B. when the knob is hardly removed.

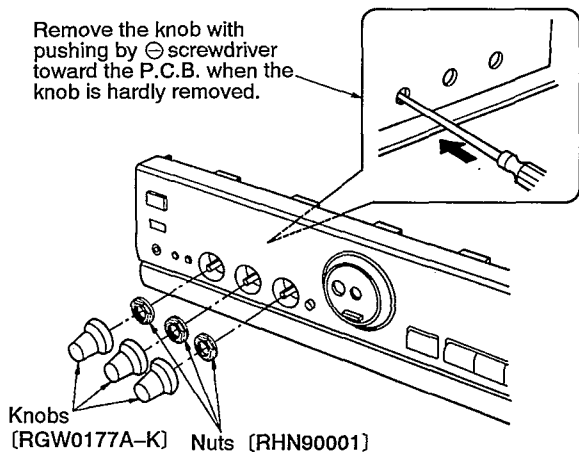

Step 6 Remove the 13 screws.

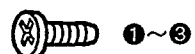
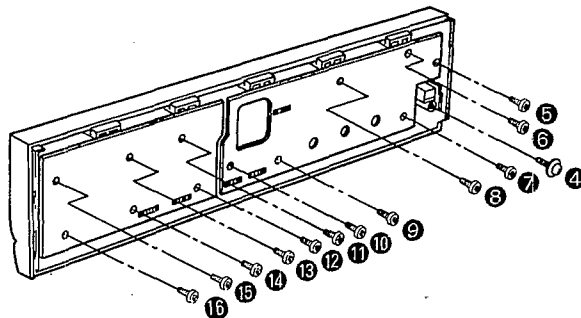

[XTBS3+8JFZ1] (Black)



[RHD26018]

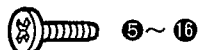

[RHD26017]

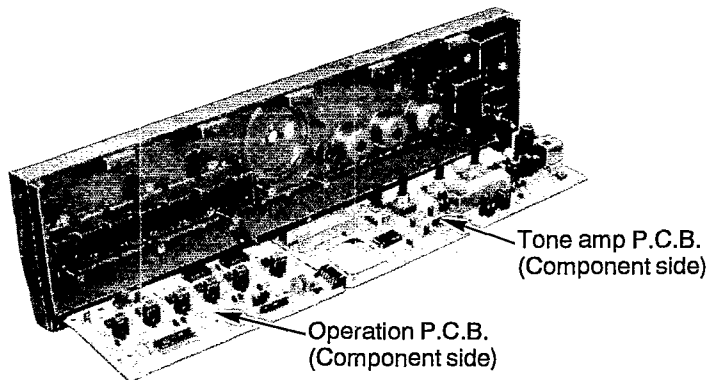

3. Checking for the Main P.C.B.

Step 1 Follow the disassembly procedure described in item 1 on page 10.

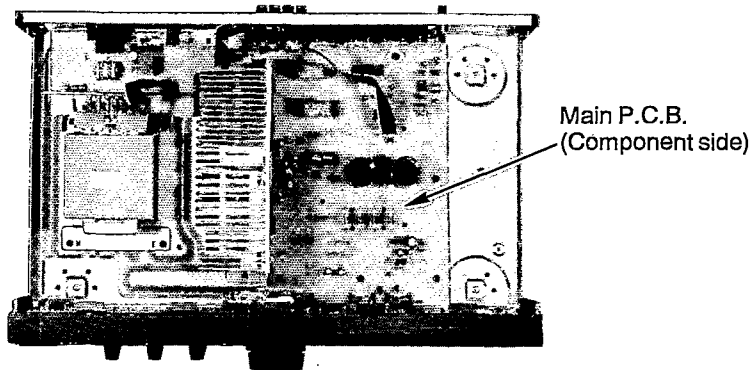

Step 2 Remove the 12 screws.

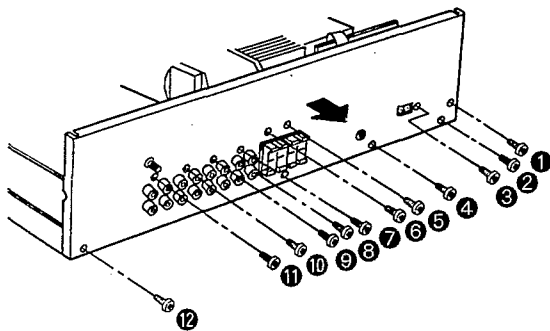

Step 3 Remove the 7 screws.

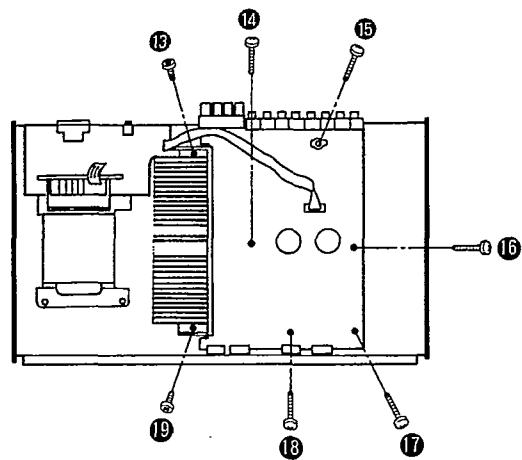

Step 4 Remove the main P.C.B. in the direction of arrow ①, ②.

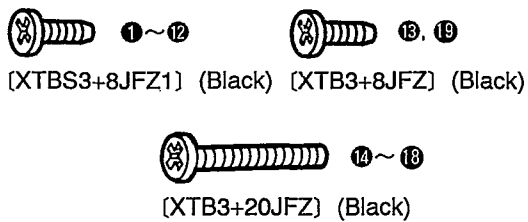
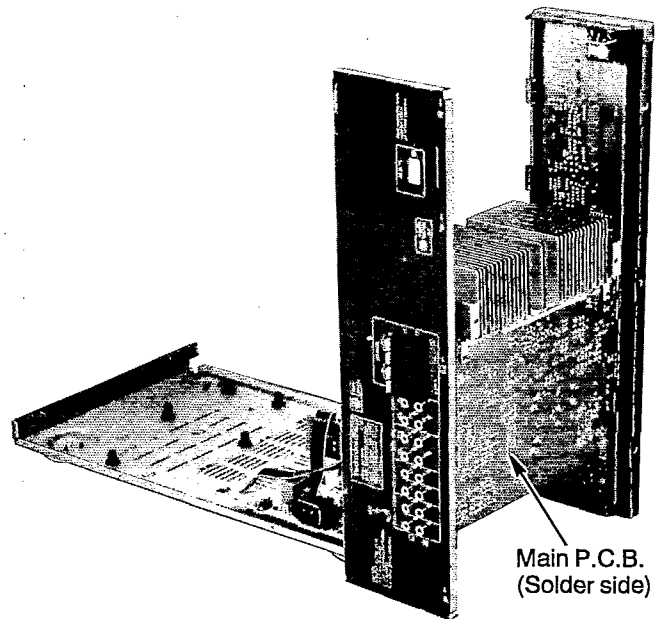
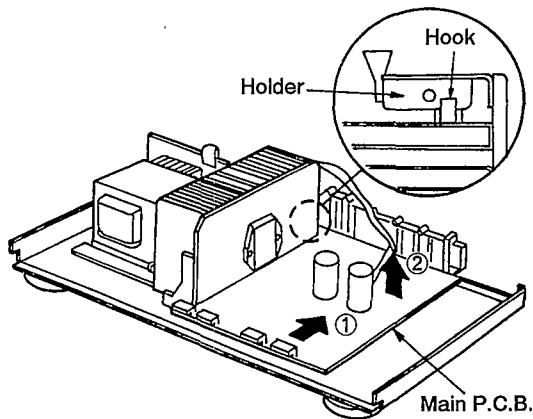

4. Replacement for power IC.

Step 1 Follow the disassembly procedure described in item 1 on page 10.

Step 2 Cut the joints as shown below.(6 portions)

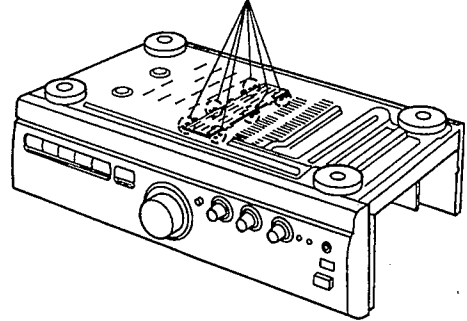
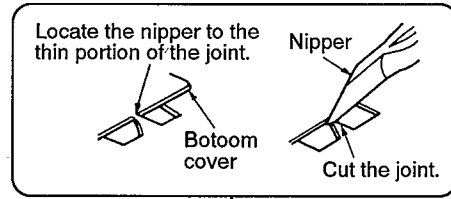

Step 4 Remove the solder of power IC.

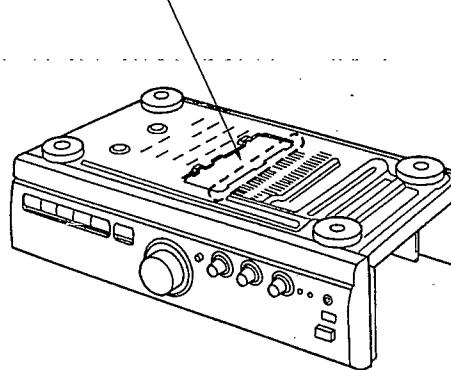

Step 3 Fold the joints.(6 portions)

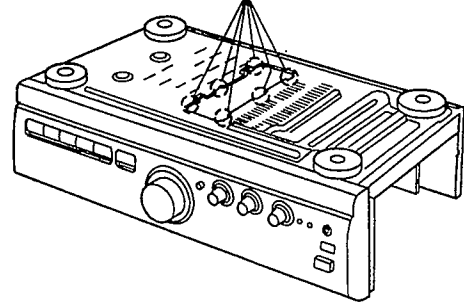
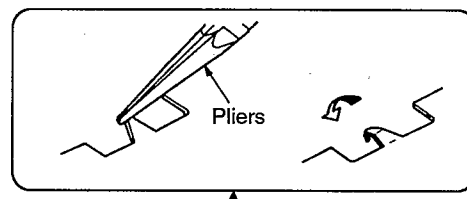

Step 5 Remove the 2 screws.

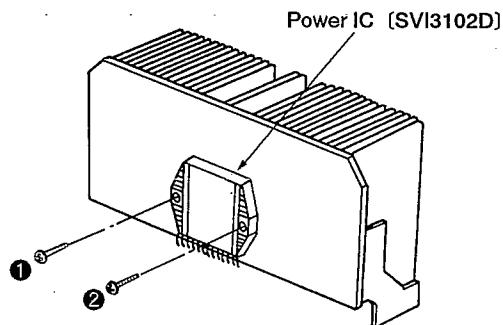

CAUTION

- After replacing the power IC, apply a sufficient quantity of compound grease (RFKX0002/SZZ0L15) between the heat sink and the power IC (Radiation of power IC)
- Tighten enough the screws (1, 2) after replacing the power IC. Otherwise, the heat radiation works little.

Step 6 Fix the bottom cover with screw.

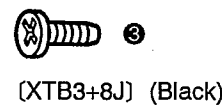
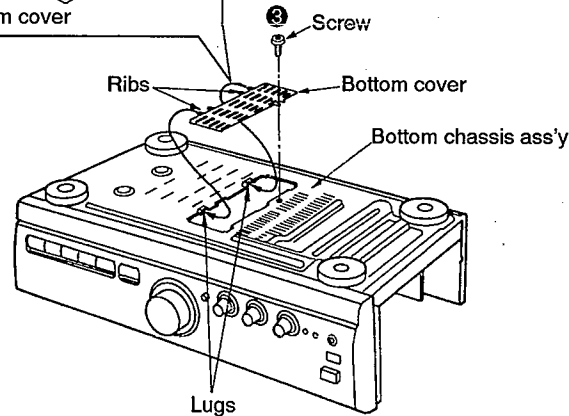
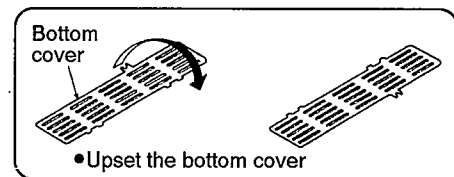

■ Block Diagram

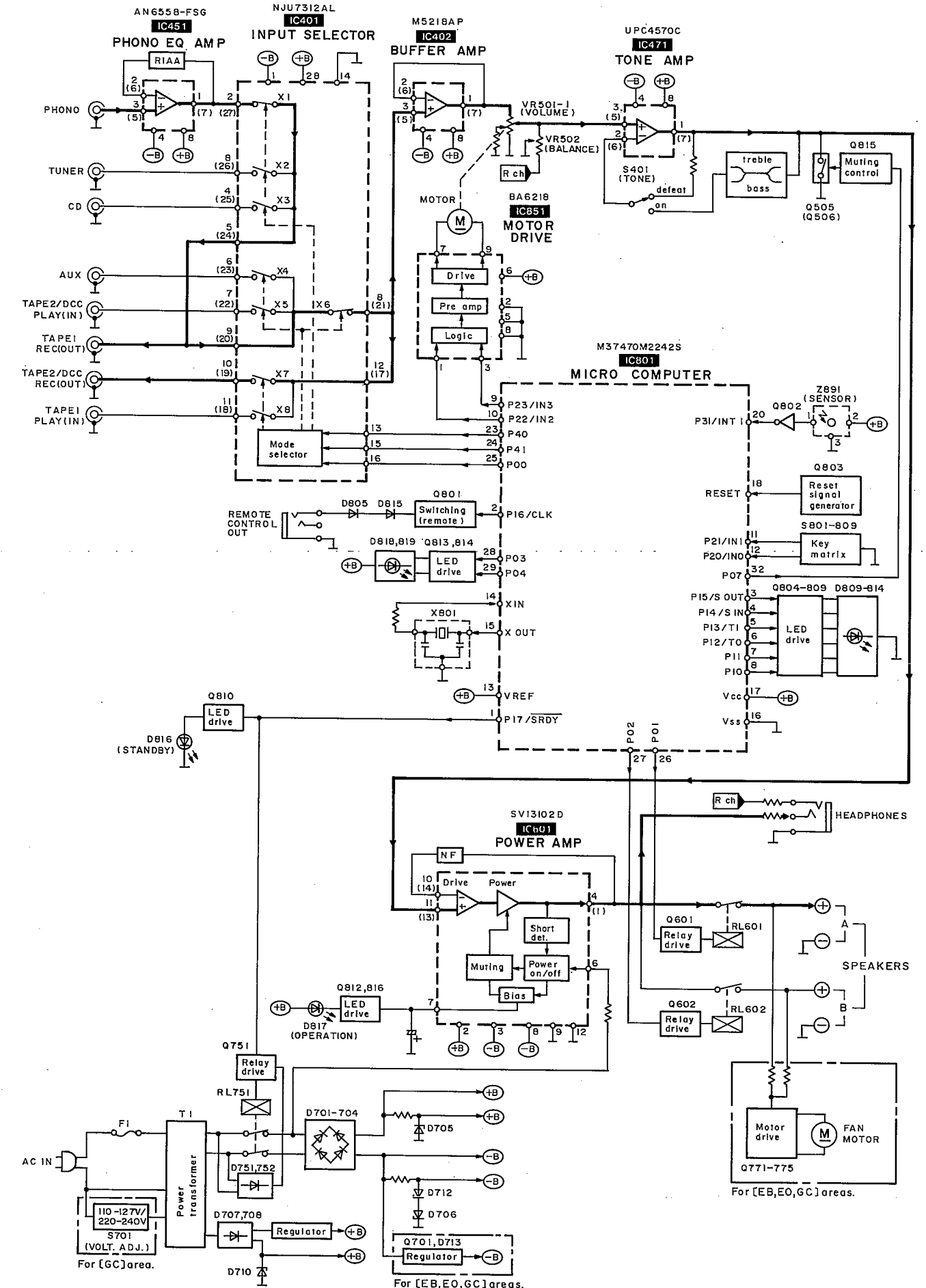

Schematic Diagram • Operation/Volume/Tone Amp./Headphones Jack Circuit (Parts list on page 29~31.)

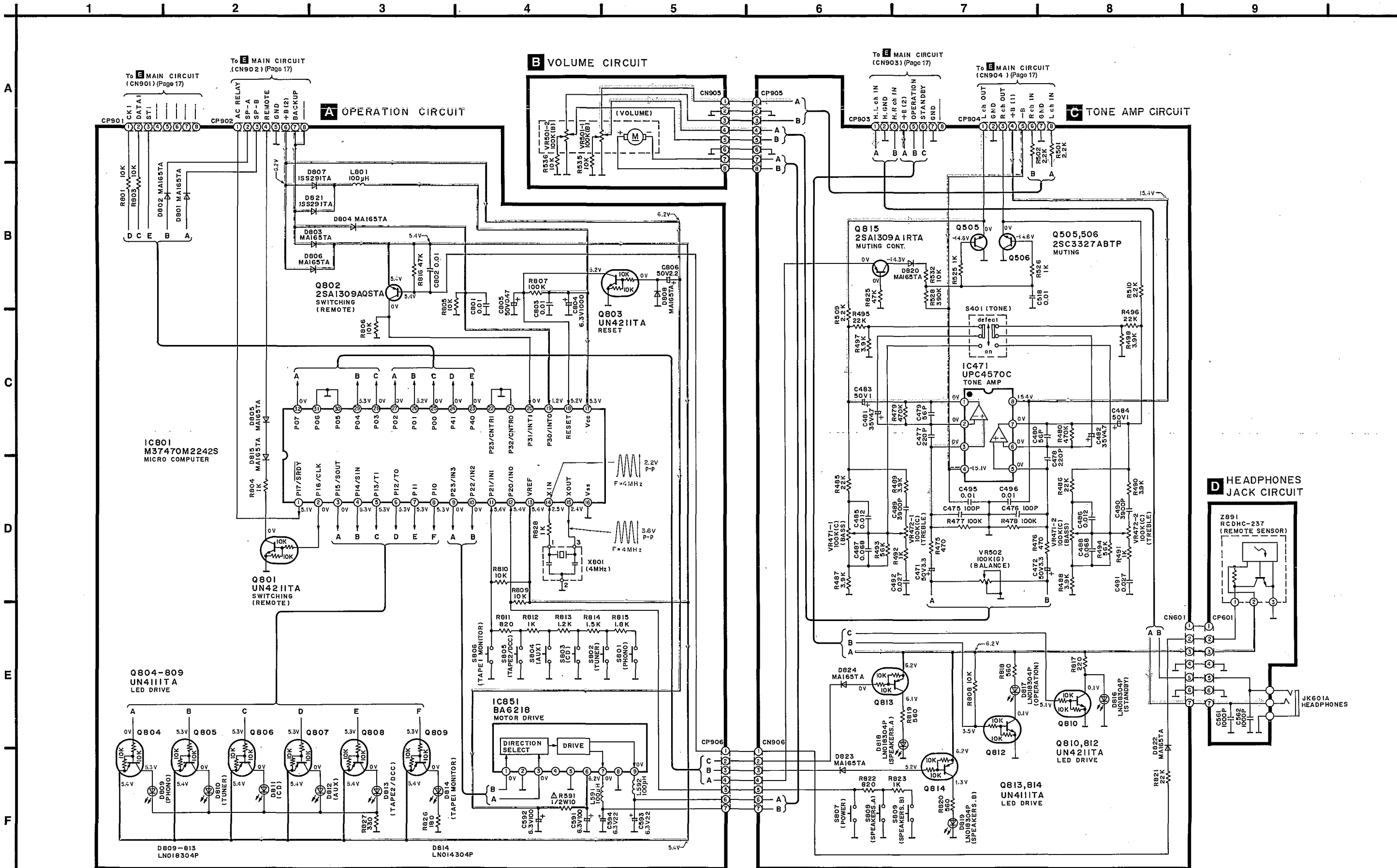

● Main/Power Supply/Power Transformer Circuit (Parts list on page 29~31.)

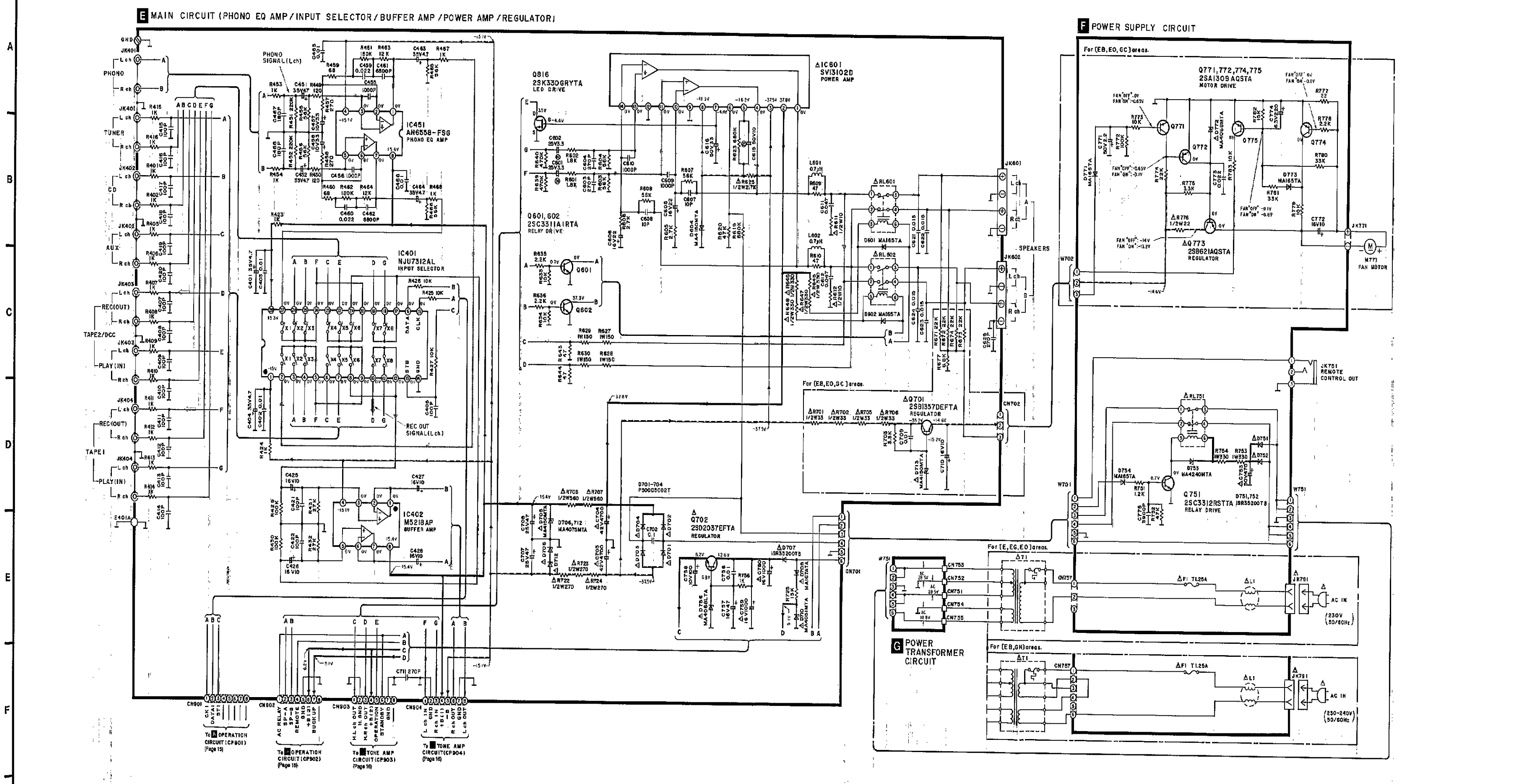
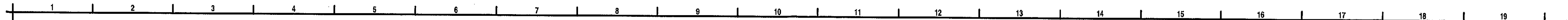

- Notes:
- S401: TONE control switch (ON/DEFEAT).
 - S701: Voltage select switch in 220 - 240 V position. For (GC) area only.
 - S801: Input selector switch (PHONO).
 - S802: Input selector switch (TUNER).
 - S803: Input selector switch (CD).
 - S804: Input selector switch (AUX).
 - S805: Input selector switch (TAPE 2/DCC).
 - S806: TAPE 1 MONITOR switch.
 - S807: Power Standby (ON) switch.
 - S808: Speaker select switch (SPEAKER A).
 - S809: Speaker select switch (SPEAKER B).

● Indicated voltage values are the standard values for the unit measured by the DC electronic circuit tester (high-impedance) with the chassis taken as standard. Therefore, there may exist some errors in the voltage values, depending on the internal impedance of the DC circuit tester. No mark: Power ON

● Important safety notice:
Components identified by Δ mark have special characteristics important for safety. Furthermore, special parts which have purposes of fire-retardant (resistors), high-quality sound (capacitors), low-noise (resistors), etc. are used. When replacing any of components, be sure to use only manufacturer's specified parts shown in the parts list.

● This schematic diagram may be modified at any time with the development of new technology.

● Caution!
IC and LSI are sensitive to static electricity. Secondary trouble can be prevented by taking care during repair. Cover the parts boxes made of plastics with aluminum foil. Ground the soldering iron. Put a conductive mat on the work table. Do not touch the legs of IC or LSI with the fingers directly.

- Voltage and signal line
- : Positive voltage line.
 - - - : Negative voltage line.
 - : Phono signal line.
 - : Recording output signal line.

● The supply part number is described alone in the replacement parts list.

Part No.	Production Part No.	Supply Part No.
Z891	RCDHC-237-E	RCDHC-237

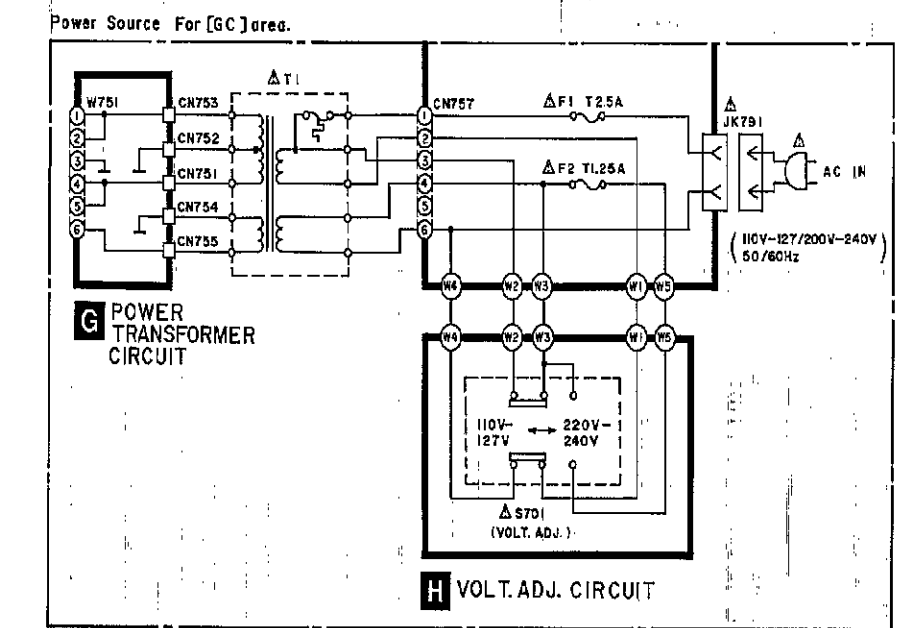

Wiring Connection Diagram

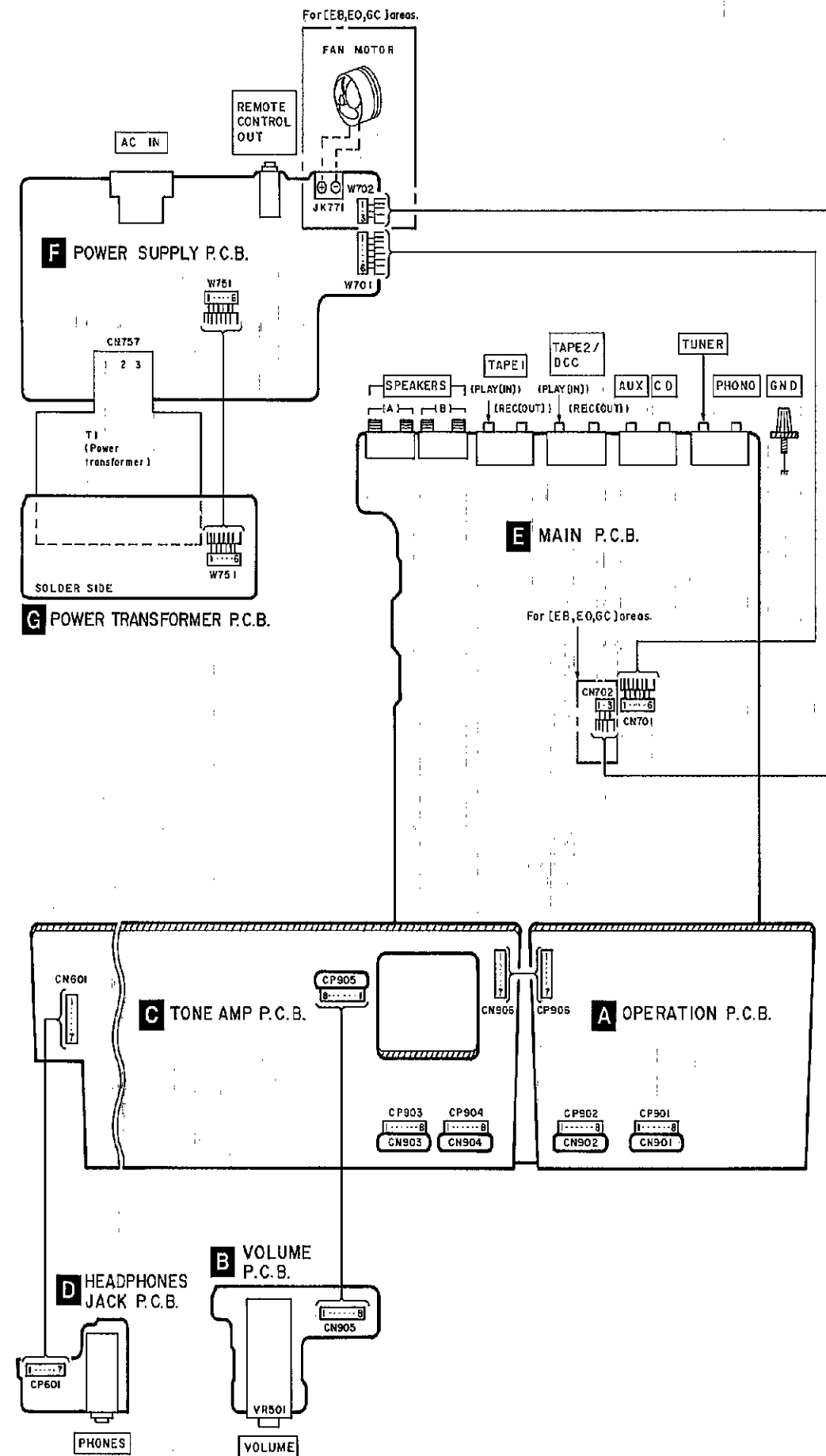

Printed Circuit Board Diagram

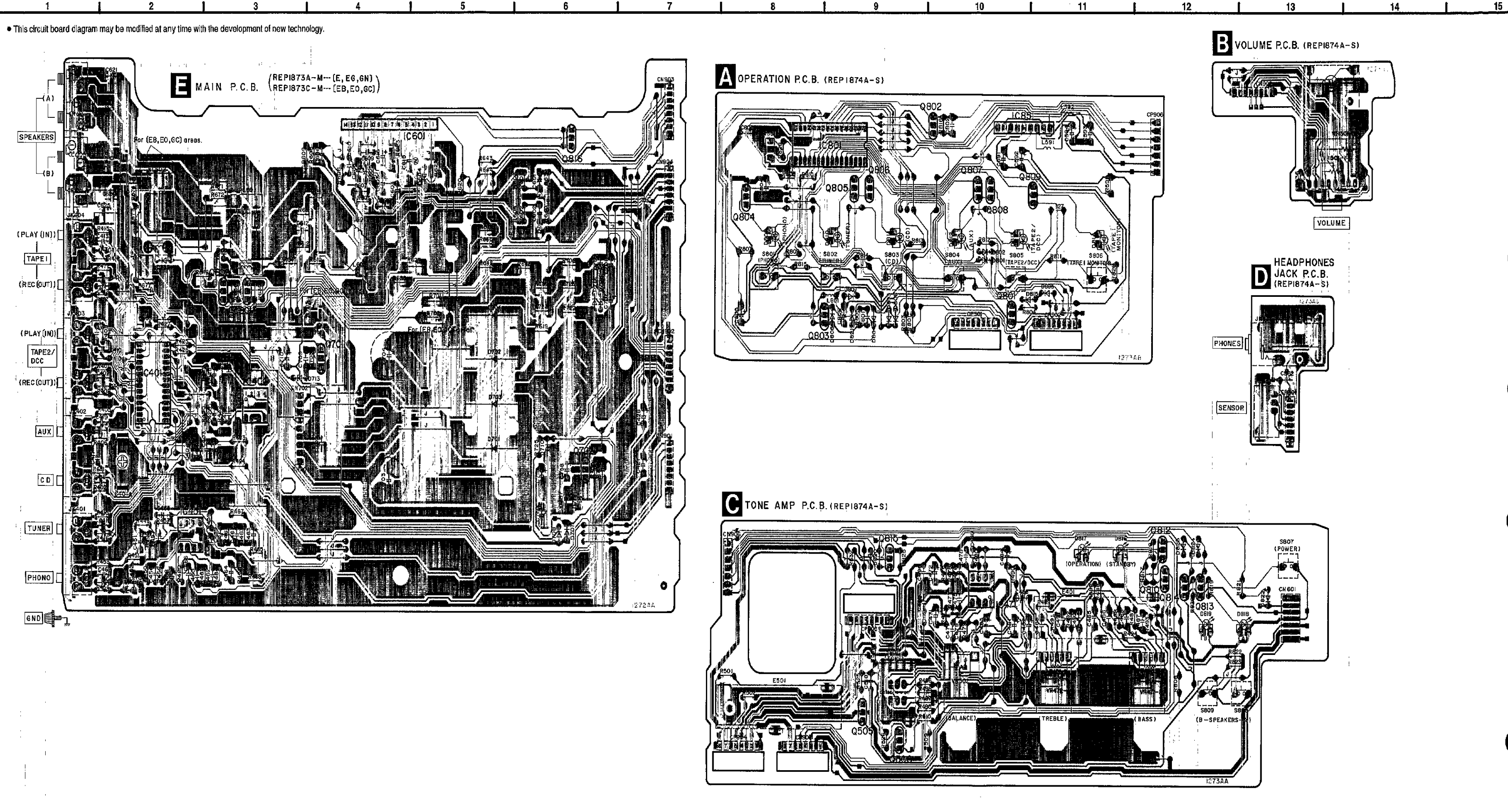

A OPERATION P.C.B. (REP1874A-S)

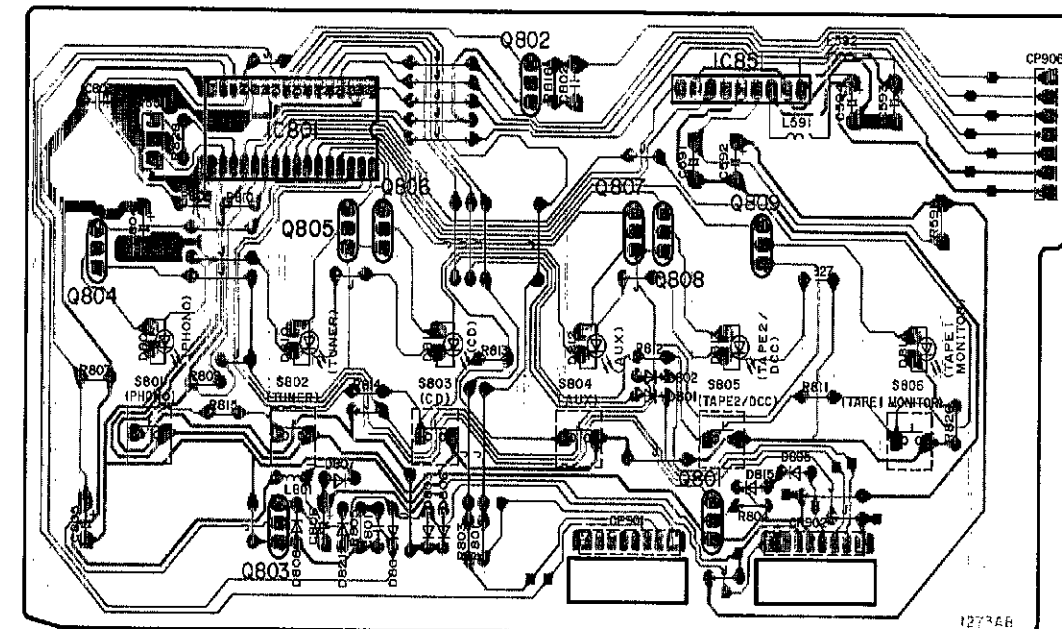

C TONE AMP P.C.B. (REP1874A-S)

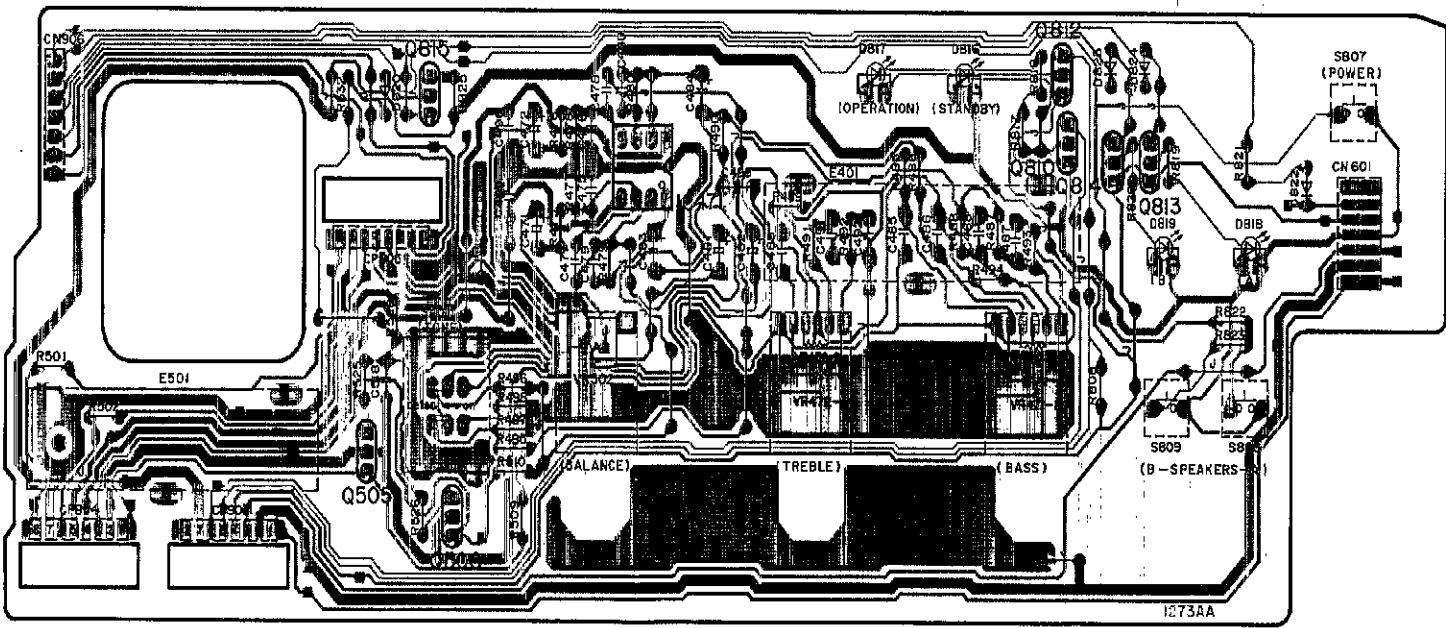

B VOLUME P.C.B. (REP1874A-S)

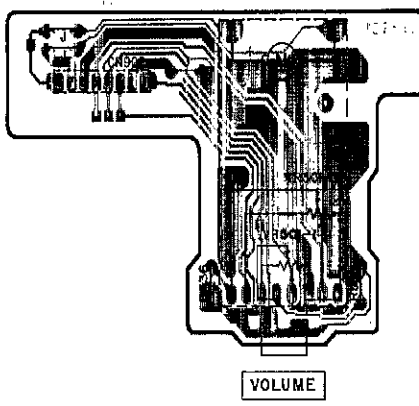

D HEADPHONES JACK P.C.B. (REP1874A-S)

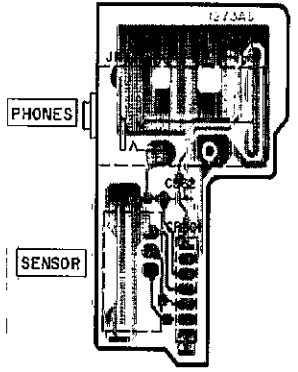

F POWER SUPPLY P.C.B. (REP1875A-P... [E,EG]
REP1875C-P... [EB]
REP1875E-P... [EO]
REP1875H-P... [GN])

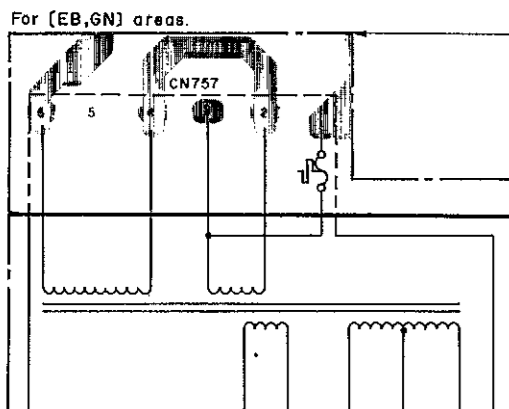
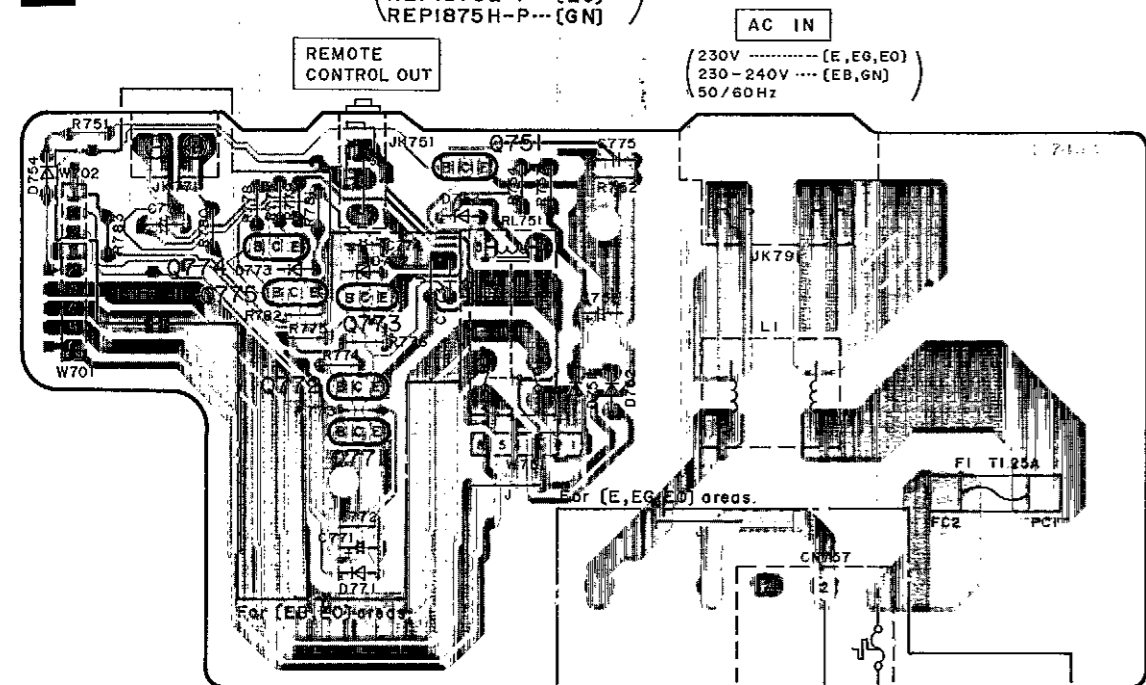

G POWER TRANSFORMER P.C.B. (REP1875A-P... [E,EG]
REP1875C-P... [EB]
REP1875E-P... [EO]
REP1875H-P... [GN])

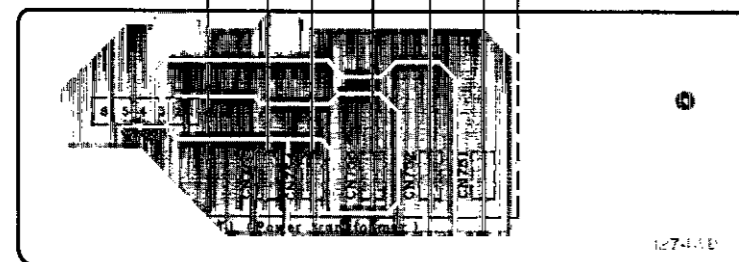

Power Source P.C.B. For [GC] area.

F POWER SUPPLY P.C.B. (REP1875G-P)

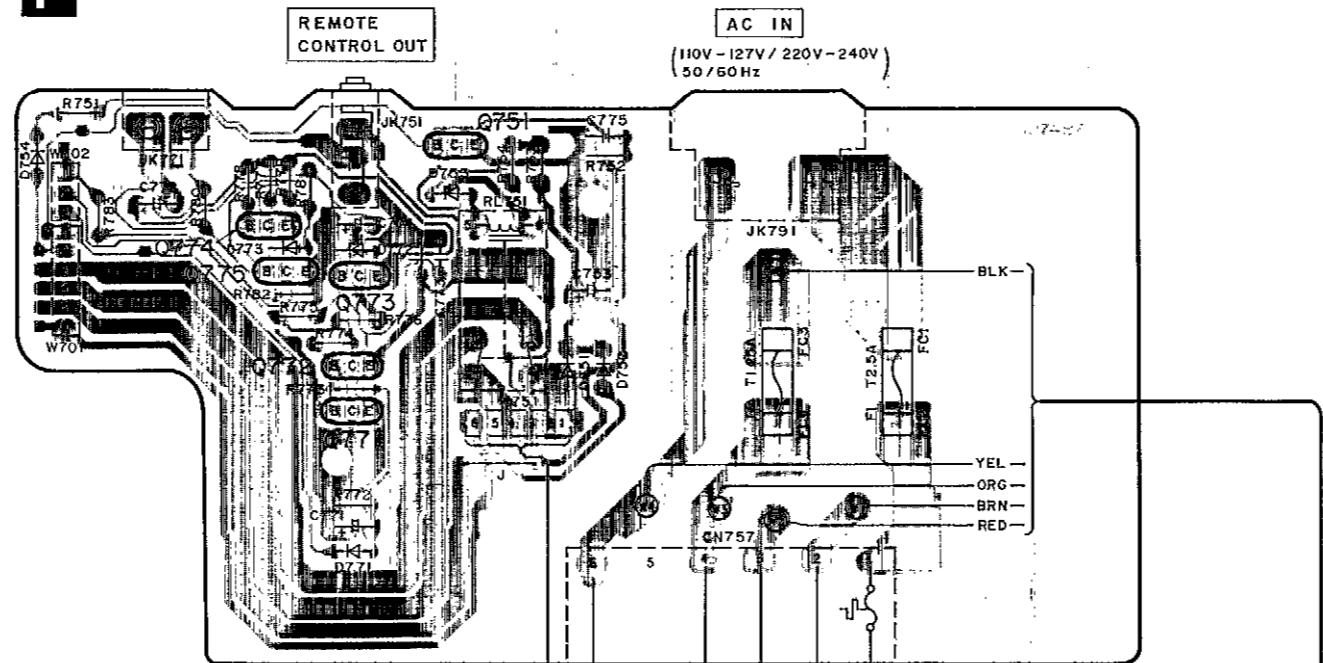

H VOLT. ADJ. P.C.B. (REP1875G-P)

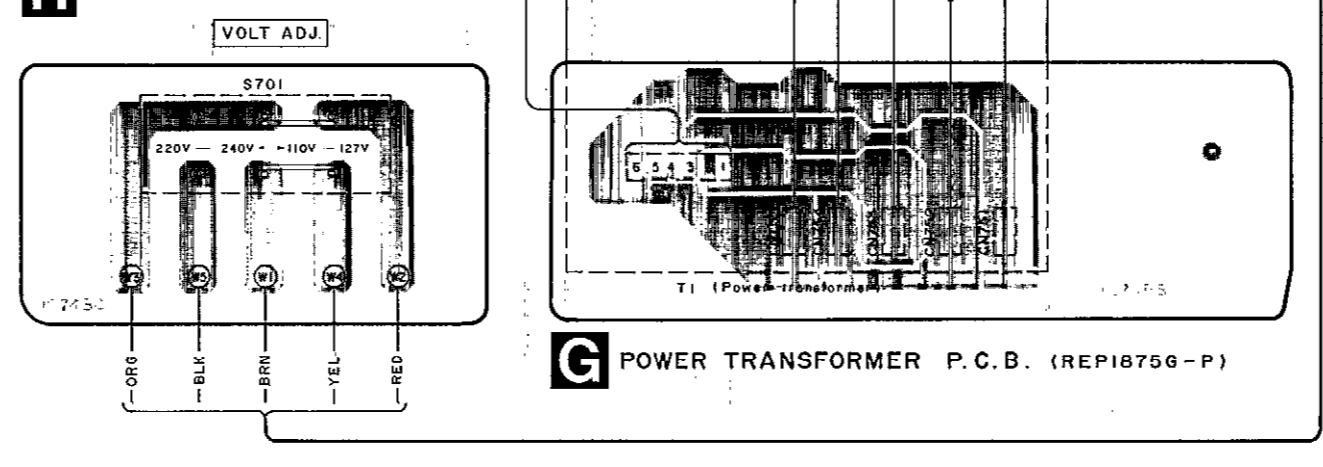

G POWER TRANSFORMER P.C.B. (REP1875G-P)

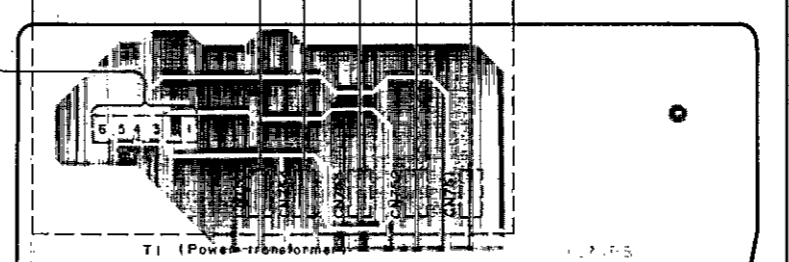

• Terminal guide of IC's, transistors and diodes

M5218AP 	AN6558-FSG 	M37470M2242S 	UPC4570C 8 Pin NJU7312AL 28 Pin 	SVI3202D
BA6218 	2SB621AQSTA 	2SA1309AIRTA 2SA1309A-R 2SC3311AIRTA 2SC3312R UN4111 UN4211 	2SC3327-A 	2SB1357DEFTA 2SD2037EFTA
2SK330GRYTA 	MA165 MA167 1SS291TA 1SR35200TB 	MA4051MTA MA4068L MA4068M MA4075MTA 	P300D5002T 	
MA4150M MA4160M MA4240H 	LN014304P LN018304P 			

■ Function of IC Terminals

IC801 (M37470M2242S)

Pin No.	Terminal Name	I/O	Function
1	P17/SRDY	O	Relay (Power SW) drive and LED (STANDBY) drive signal output.
2	P16/CLK	O	Remote control signal output.
3	P15/SOUT	O	LED (PHONO) drive signal output.
4	P14/SIN	O	LED (TUNER) drive signal output.
5	P13/TI	O	LED (CD) drive signal output.
6	P12/TO	O	LED (AUX) drive signal output.
7	P11	O	LED (TAPE2/DCC) drive signal output.
8	P10	O	LED (TAPE1 MONITOR) drive signal output.
9	P23/IN3	O	Motor (volume control) drive signal output.
10	P22/IN2	O	
11	P21/IN1	I	Input select switch signal input.
12	P20/IN0	I	Switch (POWER, SPEAKER A, SPEAKER B) signal input.
13	VREF	I	Reference voltage input.
14	XIN	I	Oscillator signal I/O terminal. (4 MHz)
15	XOUT	O	GND terminal.
16	VSS	—	GND terminal.
17	VCC	I	Power supply (+5V).

Pin No.	Terminal Name	I/O	Function
18	RESET	I	System reset signal input.
19	P30/INTO	I	Back-up detect signal input.
20	P31/INTI	I	Remote control receive signal input.
21	P32/CNRO	—	No used. Connected to GND.
22	P33/CNRI	—	No used. Connected to GND.
23	P40	O	Strobe signal input for Input Selector IC (IC401).
24	P41	O	Clock signal input for Input Selector IC (IC401).
25	P00	O	Data signal input for Input Selector IC (IC401).
26	P01	O	SPEAKER A select signal output.
27	P02	O	
28	P03	O	LED (SPEAKER A) drive signal output.
29	P04	O	LED (SPEAKER B) drive signal output.
30	P05	—	No used. Connected to GND.
31	P06	—	No used. Connected to GND.
32	P07	O	Audio muting control signal output.

■ Replacement Parts List

Notes: *Important safety notice: Components identified by Δ mark have special characteristics important for safety. Furthermore, special parts which have purposes of fire-retardant (resistors), high-quality sound (capacitors), low-noise (resistors), etc. are used. When replacing any of components, be sure to use only manufacturer's specified parts shown in the parts list. *The parenthesized indications in the Remarks columns specify the areas. (Refer to the cover page for area.) Parts without these indications can be used for all areas. *Remote Control Ass'y: Supply period for three years from termination of production. *The "(SF)" mark denotes the standard part.			
Ref. No.	Part No.	Part Name & Description	Remarks
		INTEGRATED CIRCUIT(S)	
IC401	KJU7312AL	I. C. INPUT SELECTOR	
IC402	M5218AP	I. C. BUFFER AMP.	
IC451	AN6558-FSG	I. C. PHONO EQ AMP.	
IC471	UPC4570C	I. C. TONE AMP.	
IC601	SV13102D	I. C. POWER AMP.	Δ
IC801	M37470M2242S	I. C. MICRO COMPUTER	
IC851	BA621B	I. C. MOTOR DRIVE	
		TRANSISTOR(S)	
Q505, 506	2SC3327-A	TRANSISTOR	
Q601, 602	2SC3311A1RTA	TRANSISTOR	
Q701	2SB1357DEFTA	TRANSISTOR	(EB) (EO) (GC) Δ
Q702	2SD2037EFTA	TRANSISTOR	Δ
Q751	2SC3312R	TRANSISTOR	
Q771, 772	2SA1309A-R	TRANSISTOR	(EB) (EO) (GC)
Q773	2SB621AQSTA	TRANSISTOR	(EB) (EO) (GC) Δ
Q774, 775	2SA1309A-R	TRANSISTOR	(EB) (EO) (GC)
Q801	UN4211	TRANSISTOR	
Q802	2SA1309A-R	TRANSISTOR	
Q803	UN4211	TRANSISTOR	
Q804-809	UN4111	TRANSISTOR	
Q810	UN4211	TRANSISTOR	
Q812	UN4211	TRANSISTOR	
Q813, 814	UN4111	TRANSISTOR	
Q815	2SA1309A1RTA	TRANSISTOR	
Q816	2SK330GRYA	TRANSISTOR	
		DIODE(S)	
D601, 602	MA165	DIODE	
D604	MA4160M	DIODE	
D701-704	P30005002T	DIODE	Δ
D705	MA4150M	DIODE	Δ
D706	MA4075MTA	DIODE	Δ
D707	1SR35200TB	DIODE	Δ
D708	MA167	DIODE	Δ
D710	MA4051MTA	DIODE	Δ
D712	MA4075MTA	DIODE	Δ
D713	MA4150M	DIODE	(EB) (EO) (GC) Δ
D751, 752	1SR35200TB	DIODE	Δ
D753	MA4240H	DIODE	
D754	MA165	DIODE	
		TRANSFORMER(S)	
T1	RTP1V5001-W	POWER TRANSFORMER	(E) (EG) (EO) Δ
T1	RTP1V5001-W	POWER TRANSFORMER	(EB) (GN) Δ
T1	RTP2M5005	POWER TRANSFORMER	(GC) Δ
		OSCILLATOR(S)	
X801	EF0EC4004T4	OSCILLATOR (4MHz)	
		FUSE(S)	
F1	XRA2C10TB0	FUSE 250V T1. 25A	(E) (EB) (EG) (EO) (GN) Δ

Ref. No.	Part No.	Part Name & Description	Remarks
F1	XBA2C25TB0	FUSE 250V T2. 5A	(GC) Δ
F2	XBA2C10TB0	FUSE 250V T1. 25A	(GC) Δ
		SWITCH(S)	
		RELAY(S)	
S401	ES868047	SW. TONE	
S701	ESD26200A	SW. VOLTAGE SELECTOR	(GC) Δ
S801	EVQ21405R	SW. PHONO	
S802	EVQ21405R	SW. TUNER	
S803	EVQ21405R	SW. CD	
S804	EVQ21405R	SW. AUX	
S805	EVQ21405R	SW. TAPE2/DCC	
S806	EVQ21405R	SW. TAPE1 MONITOR	
S807	EVQ21405R	SW. POWER	
S808	EVQ21405R	SW. SPEAKER(A)	
S809	EVQ21405R	SW. SPEAKER(B)	
		JACK(S)	
JK401	SJF3069N	PHONO/TUNER	
JK402	SJF3069N	CD/AUX	
JK403	SJF3069N	TAPE2/DCC	
JK404	SJF3069N	TAPE1	
JK601A	RJJB3TS01	HEADPHONES JACK	
JK601	RJR0054M	SPEAKER(A)	
JK602	RJR0054M	SPEAKER(B)	
JK751	RJJC3TR01	REMOTE OUT	
JK771	RJS1A7002-1	FAN CONNECTOR	(EB) (EO) (GC)
JK791	SJS9236	AC INLET	(E) (EB) (EG) (EO) (GC) Δ
JK791	SJS916	AC INLET	(GN) Δ
		CONNECTOR(S)	
CN601	RJU057W007	SOCKET (7P)	
CN701	RJS1A6606	SOCKET (6P)	
CN702	RJS1A6603	SOCKET (3P)	(EB) (EO) (GC)
CN751-755	RJS1A1101T1	SOCKET (1P)	
CN757	SJS305-1	SOCKET (3P)	(E) (EG) (EO)
CN757	SJS702-1	SOCKET (6P)	(EB) (GC) (GN)
CN901-905	RJU003K008M1	SOCKET (8P)	
CN906	SJS50782JQH	SOCKET (7P)	
CP601	RJT057W007-1	CONNECTOR (7P)	
CP901-905	RJT003K008-1	CONNECTOR (8P)	
CP906	SJT30745JQ	CONNECTOR (7P)	
		EARTH TERMINAL(S)	
E401A	SNE1004-2	EARTH TERMINAL	
E401	RSC0377	SHIELD PLATE	
E501	RSC0377	SHIELD PLATE	
		FUSE HOLDER(S)	

Cabinet Parts Location

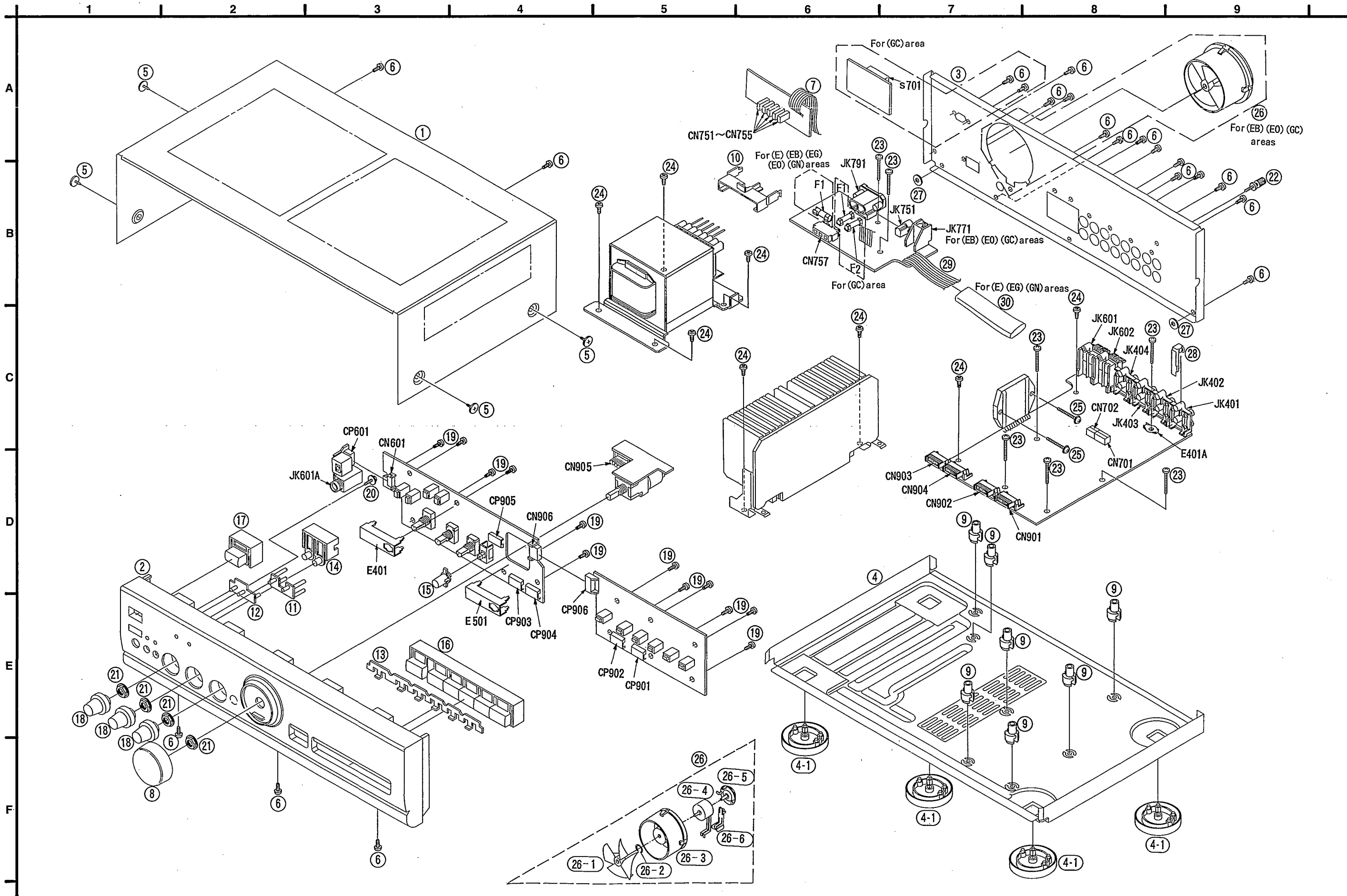

Ref. No.	Part No.	Part Name & Description	Remarks
		CABINET PARTS	
1	RKM0036E-K	TOP CABINET	(EB) (EO) (GC)
1	RKM0036D-K	TOP CABINET	(E) (EG) (GN)
2	RFKGV500E-K	FRONT PANEL ASS'Y	
3	RGR0189B-A1	REAR PANEL	(EB)
3	RGR0189A-A	REAR PANEL	(E) (EG)
3	RGR0189B-B	REAR PANEL	(EO)
3	RGR0189C-A	REAR PANEL	(GC)
3	RGR0189A-B1	REAR PANEL	(GN)
4	RFKJAGX170PK	BOTTOM CHASSIS ASS'Y	
4-1	RKA0053-A	FOOT	
5	RHD30035-K	SCREW	
6	XTBS3+8JFZ1	SCREW	
7	RFKEUV500EBK	FLAT CABLE (6P)	
8	RGW0201-K	MAIN VOLUME KNOB	
9	RKQ0089	SPACER	
10	RMN0191	HOLDER	
11	RGL0184A-Q1	LEADING LIGHT PANEL (A)	
12	RGL0185A-Q	LEADING LIGHT PANEL (B)	
13	RGL0229-Q	LEADING LIGHT PANEL (C)	
14	RGU0887A-K1	SPEAKER BUTTON	
15	RGU0889-K	TONE BUTTON	
16	RGU1038-K	INPUT SELECTOR BUTTON	
17	RGU1042-K	POWER BUTTON	
18	RGW0177A-K	TONE KNOB	
19	RHD26017	SCREW	
20	RHD26018	SCREW	
21	RHN90001	NUT	
22	SNE2123	GND SCREW	
23	XTB3+20JFZ	SCREW	
24	XTB3+8JFZ	SCREW	
25	XTW3+15T	SCREW	
26	REM0020	FAN ASS'Y	(EB) (EO) (GC)
26-1	SHE232-1	FAN	(EB) (EO) (GC)
26-2	SUS271	SPRING	(EB) (EO) (GC)
26-3	RMQ0209-K	FAN CASE	(EB) (EO) (GC)
26-4	MDN-4RB4MRC	MOTOR	(EB) (EO) (GC)
26-5	RMQ0208-K	FAN CAP	(EB) (EO) (GC)
26-6	RMQ0212-K	TERMINAL CAP	(EB) (EO) (GC)
27	RMG0332-K	RUBBER	
28	RSC0105-2	SHIELD PLATE	
29	RFKEUV500EAK	FLAT CABLE (6P)	(E) (EG) (GN)
29	RFKEUV500EOK	FLAT CABLE (9P)	(EB) (EO) (GC)
30	RFKEUV500ECK	PROTECT TUBE	(E) (EG) (GN)
		PACKING MATERIALS	
P1	RPG2022	PACKING CASE	(EB)
P1	RPG2021	PACKING CASE	(E) (EG) (EO) (GC) (GN)
P2	RPNO684-1	PAD	

Ref. No.	Part No.	Part Name & Description	Remarks
P3	XZB24X34C04	PROTECTION COVER	
P4	RPQ0164	PAD	
P5	RP10032	SHEET	(EB) (GN)
P6	XZB50X65A02Z	PROTECTION COVER	
		ACCESSORIES	
A1	RAK-SU129WH	REMOTE CONTROL TRANSMITTER	
A1-1	RKK0057-K	BATTERY COVER	
A2	VJA0733	AC POWER SUPPLY CORD	(EB) Δ (SF)
A2	RJA0019-2K	AC POWER SUPPLY CORD	(E) (EG) (EO) (GC) Δ (SF)
A2	RJA0036-K	AC POWER SUPPLY CORD	(GN) Δ
A3	RQA0013	WARRANTY CARD	(E) (EB) (EG) (EO)
A3	RQX7433ZA	WARRANTY CARD	(GN)
A4	RQCB0169	SERVICE CENTER LIST	
A5	RFKSUV500E-K	INSTRUCTIONS MANUAL	(E)
A5	RFKSUV500EBK	INSTRUCTIONS MANUAL	(EB) (GN)
A5	RFKSUV500EGK	INSTRUCTIONS MANUAL	(EG)
A5	RFKSUV500EOK	INSTRUCTIONS MANUAL	(EO)
A5	RFKSUV500GCK	INSTRUCTIONS MANUAL	(GC)
A6	SJP5213-2	POWER PLUG ADAPTOR	(GC) Δ

■ Packaging

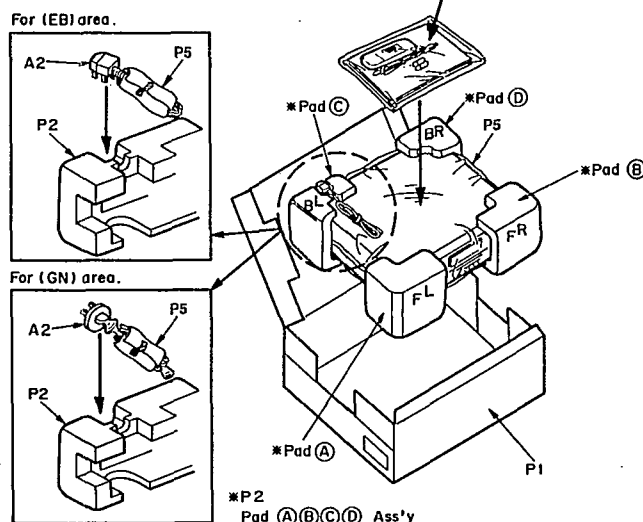
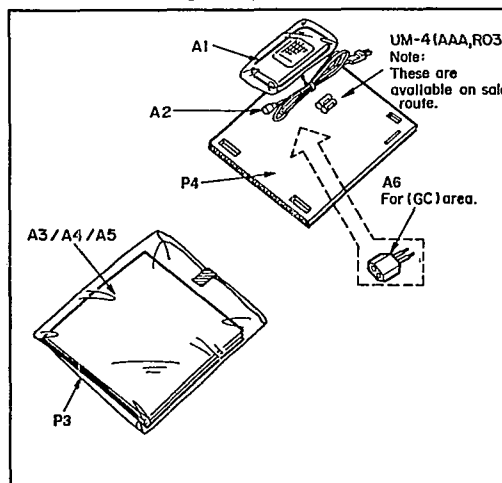

956

Cabinet Parts Location

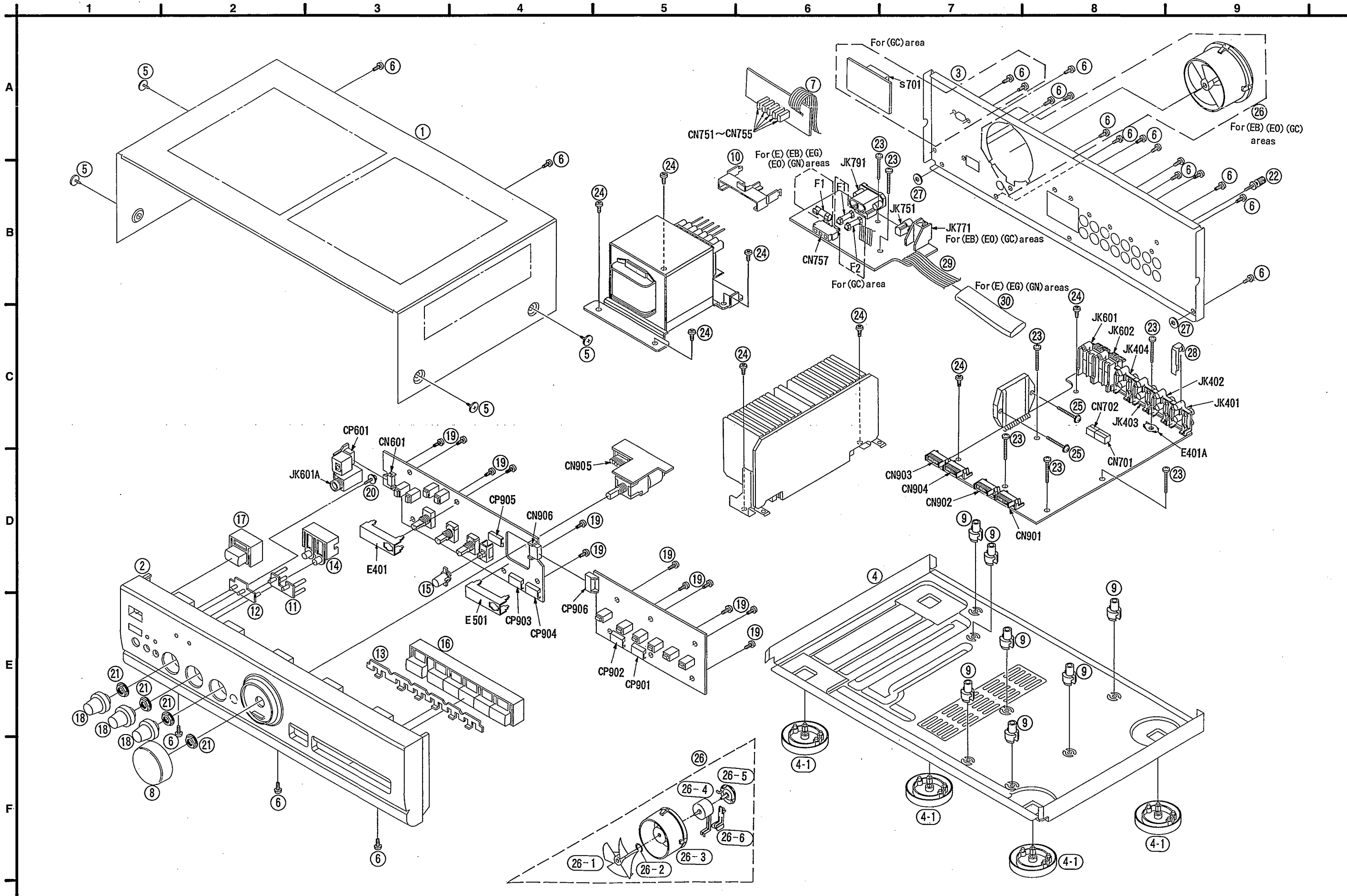

Ref. No.	Part No.	Part Name & Description	Remarks
		CABINET PARTS	
1	RKM0036E-K	TOP CABINET	(EB) (EO) (GC)
1	RKM0036D-K	TOP CABINET	(E) (EG) (GN)
2	RFKGV500E-K	FRONT PANEL ASS'Y	
3	RGR0189B-A1	REAR PANEL	(EB)
3	RGR0189A-A	REAR PANEL	(E) (EG)
3	RGR0189B-B	REAR PANEL	(ED)
3	RGR0189C-A	REAR PANEL	(GC)
3	RGR0189A-B1	REAR PANEL	(GN)
4	RFKJAGX170PK	BOTTOM CHASSIS ASS'Y	
4-1	RKA0053-A	FOOT	
5	RHD30035-K	SCREW	
6	XTBS3+8JFZ1	SCREW	
7	RFKEUV500EBK	FLAT CABLE (6P)	
8	RGW0201-K	MAIN VOLUME KNOB	
9	RKQ0089	SPACER	
10	RMN0191	HOLDER	
11	RGL0184A-Q1	LEADING LIGHT PANEL (A)	
12	RGL0185A-Q	LEADING LIGHT PANEL (B)	
13	RGL0229-Q	LEADING LIGHT PANEL (C)	
14	RGU0887A-K1	SPEAKER BUTTON	
15	RGU0889-K	TONE BUTTON	
16	RGU1038-K	INPUT SELECTOR BUTTON	
17	RGU1042-K	POWER BUTTON	
18	RGW0177A-K	TONE KNOB	
19	RHD26017	SCREW	
20	RHD26018	SCREW	
21	RHN90001	NUT	
22	SNE2123	GND SCREW	
23	XTB3+20JFZ	SCREW	
24	XTB3+8JFZ	SCREW	
25	XTW3+15T	SCREW	
26	REM0020	FAN ASS'Y	(EB) (EO) (GC)
26-1	SHE232-1	FAN	(EB) (EO) (GC)
26-2	SUS271	SPRING	(EB) (EO) (GC)
26-3	RMQ0209-K	FAN CASE	(EB) (EO) (GC)
26-4	MDN-4RB4MRC	MOTOR	(EB) (EO) (GC)
26-5	RMQ0208-K	FAN CAP	(EB) (EO) (GC)
26-6	RMQ0212-K	TERMINAL CAP	(EB) (EO) (GC)
27	RMG0332-K	RUBBER	
28	RSC0105-2	SHIELD PLATE	
29	RFKEUV500EAK	FLAT CABLE (6P)	(E) (EG) (GN)
29	RFKEUV500EOK	FLAT CABLE (9P)	(EB) (EO) (GC)
30	RFKEUV500ECK	PROTECT TUBE	(E) (EG) (GN)
		PACKING MATERIALS	
P1	RPG2022	PACKING CASE	(EB)
P1	RPG2021	PACKING CASE	(E) (EG) (EO) (GC) (GN)
P2	RPNO684-1	PAD	

Ref. No.	Part No.	Part Name & Description	Remarks
P3	XZB24X34C04	PROTECTION COVER	
P4	RPQ0164	PAD	
P5	RP10032	SHEET	(EB) (GN)
P6	XZB50X65A02Z	PROTECTION COVER	
		ACCESSORIES	
A1	RAK-SU129WH	REMOTE CONTROL TRANSMITTER	
A1-1	RKK0057-K	BATTERY COVER	
A2	VJA0733	AC POWER SUPPLY CORD	(EB) Δ (SF)
A2	RJA0019-2K	AC POWER SUPPLY CORD	(E) (EG) (EO) (GC) Δ (SF)
A2	RJA0036-K	AC POWER SUPPLY CORD	(GN) Δ
A3	RQA0013	WARRANTY CARD	(E) (EB) (EG) (EO)
A3	RQX7433ZA	WARRANTY CARD	(GN)
A4	RQCB0169	SERVICE CENTER LIST	
A5	RFKSUV500E-K	INSTRUCTIONS MANUAL	(E)
A5	RFKSUV500EBK	INSTRUCTIONS MANUAL	(EB) (GN)
A5	RFKSUV500EGK	INSTRUCTIONS MANUAL	(EG)
A5	RFKSUV500EOK	INSTRUCTIONS MANUAL	(EO)
A5	RFKSUV500GCK	INSTRUCTIONS MANUAL	(GC)
A6	SJP5213-2	POWER PLUG ADAPTOR	(GC) Δ

■ Packaging

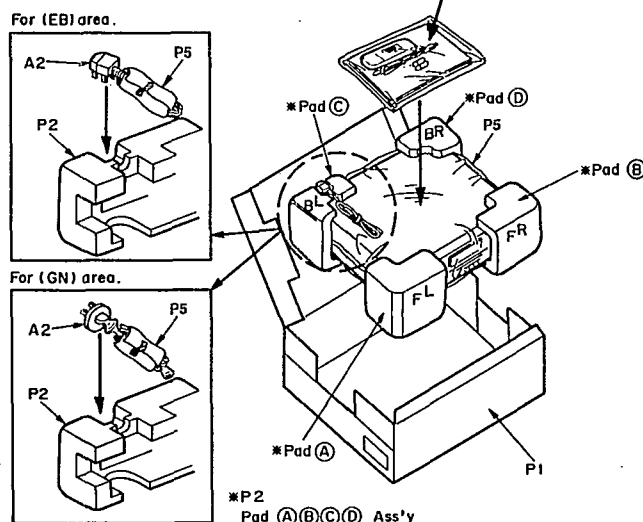
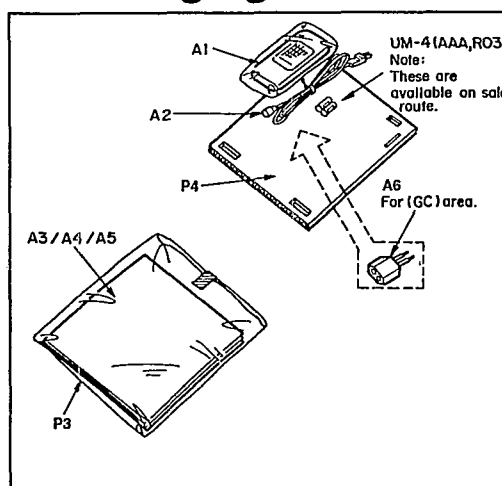

956