

A
B
C
D
E
F
G

A PHONO TERMINAL CIRCUIT

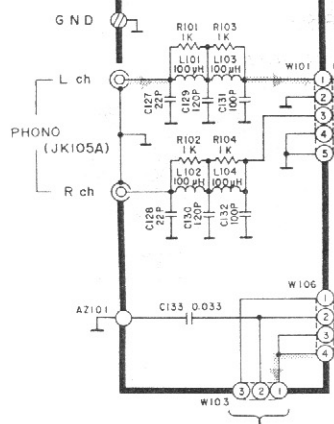

B PHONO SELECTOR/PHONO EQ AMP CIRCUIT

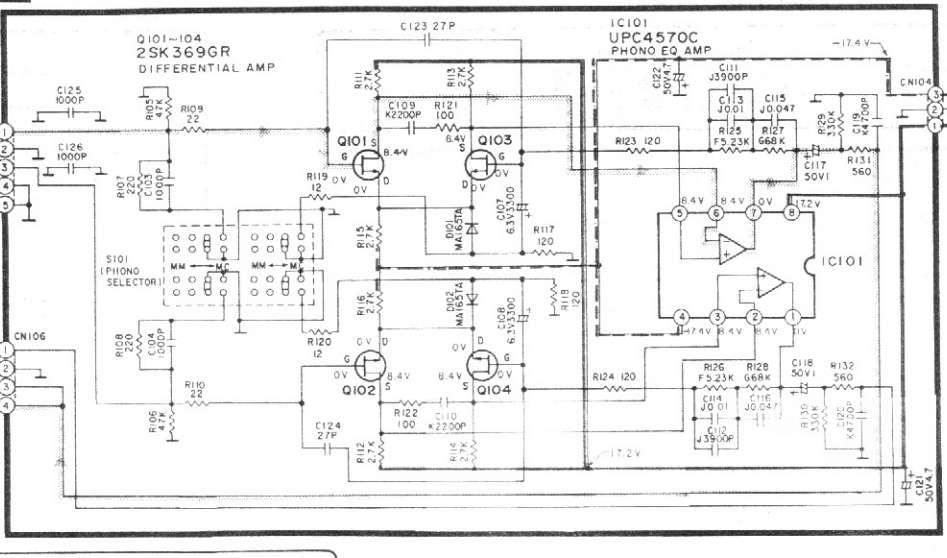

C INPUT/OUTPUT TERMINAL CIRCUIT

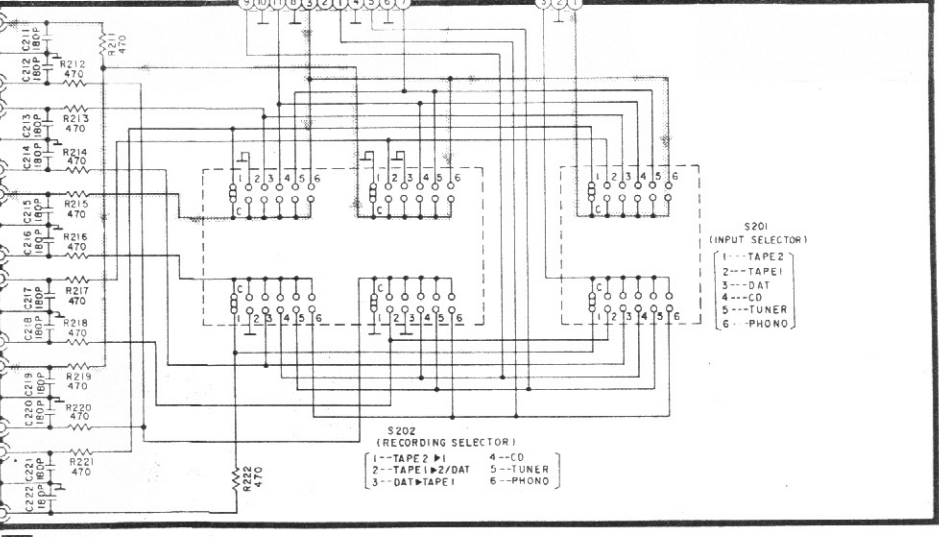
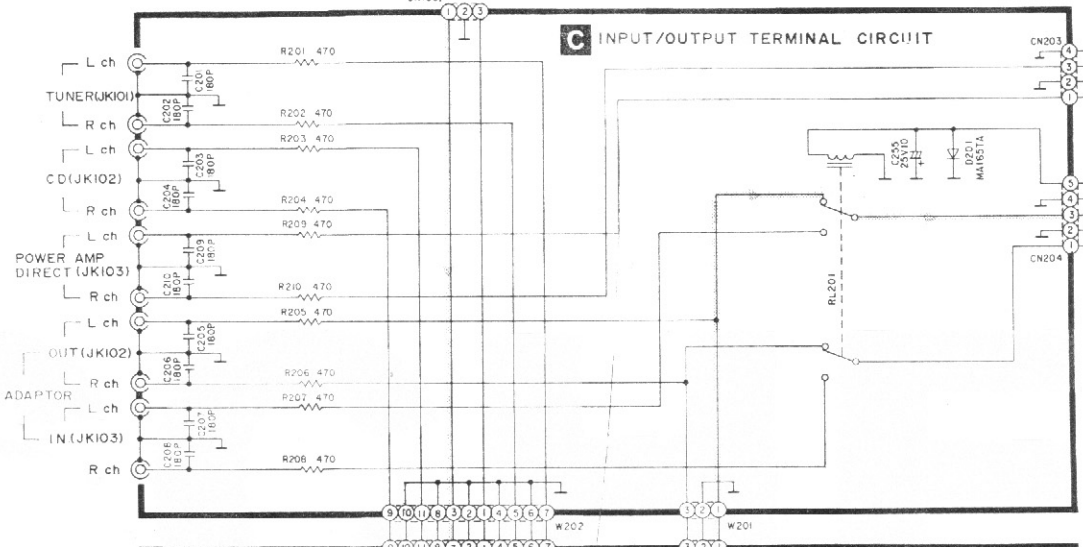

D DAT/TAPE1-2 INPUT/OUTPUT TERMINAL CIRCUIT

- S201 (INPUT SELECTOR)
- 1---TAPE2
 - 2---TAPE1
 - 3---DAT
 - 4---CD
 - 5---TUNER
 - 6---PHONO

- S202 (RECORDING SELECTOR)
- 1---TAPE 2 ▶
 - 2---TAPE 1 ▶/DAT
 - 3---DAT▶TAPE 1
 - 4---CD
 - 5---TUNER
 - 6---PHONO

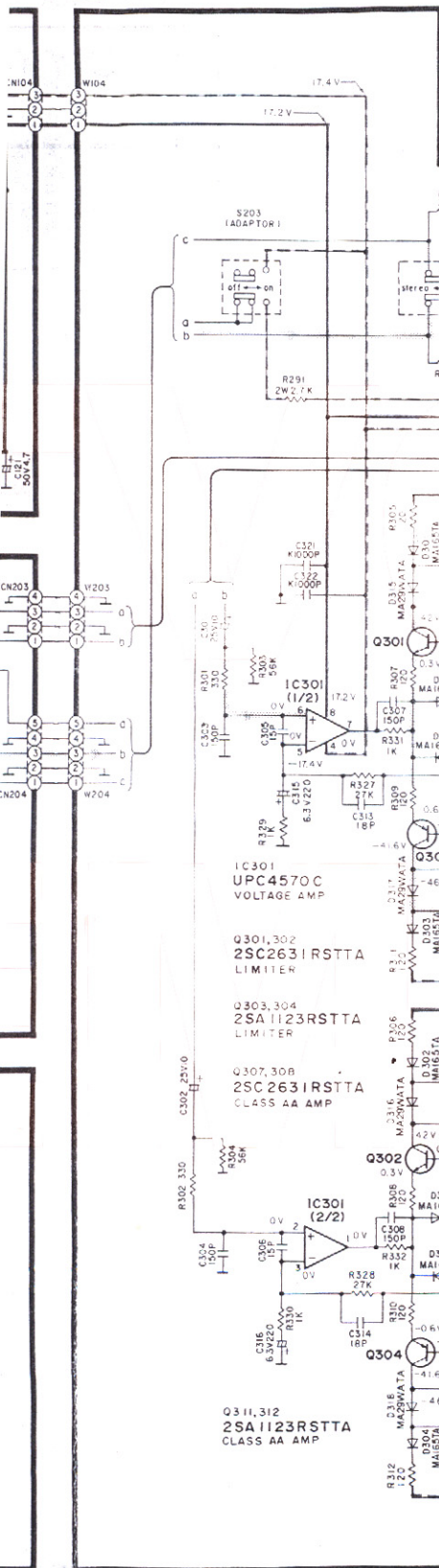
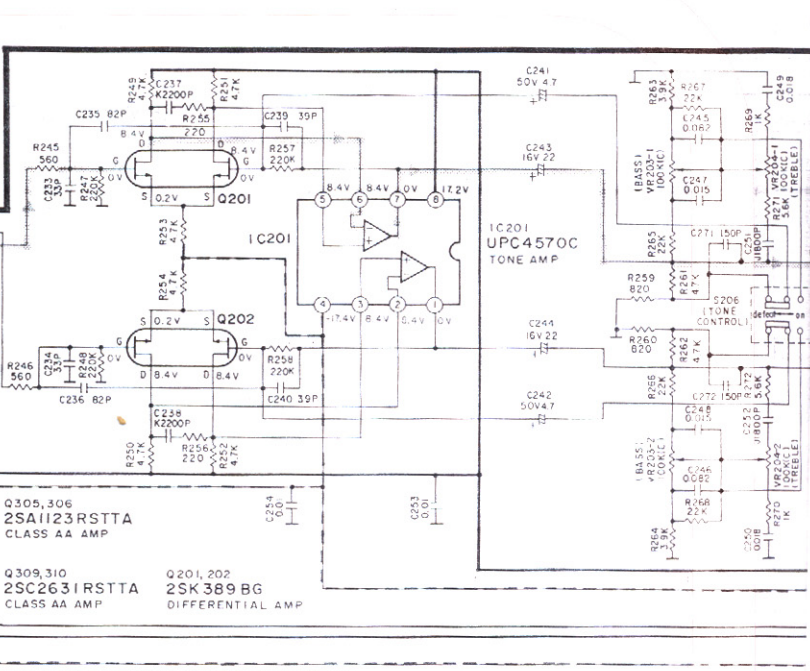
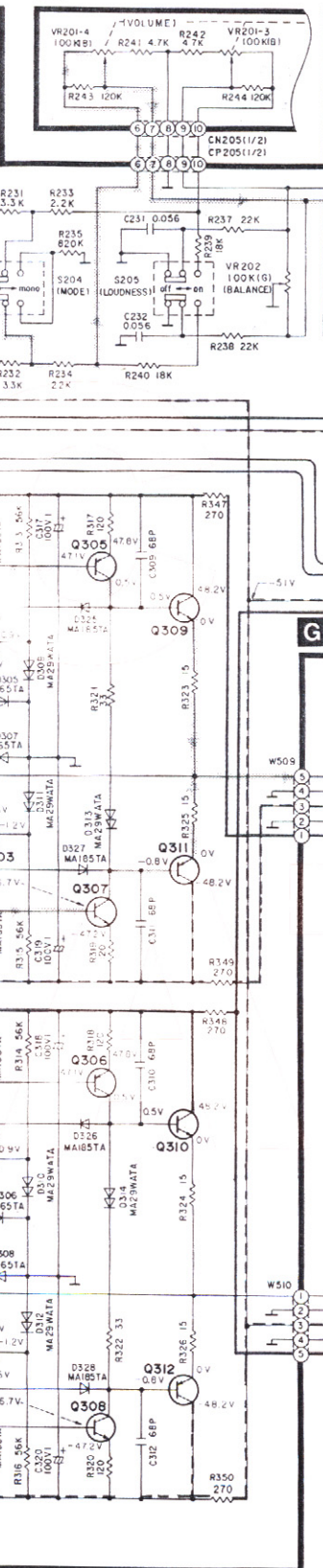
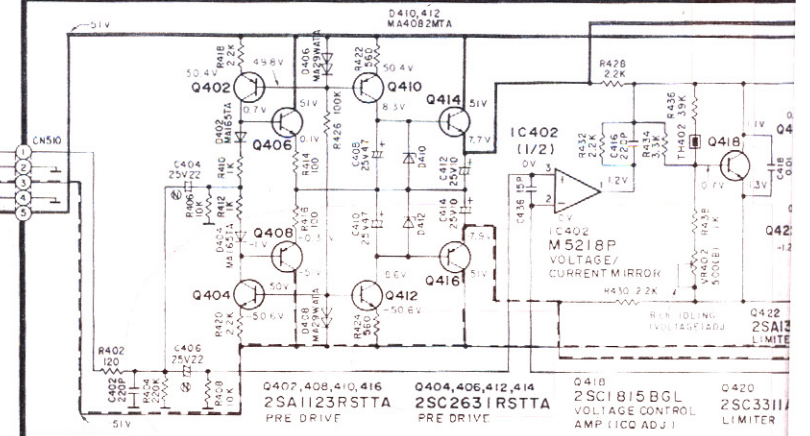
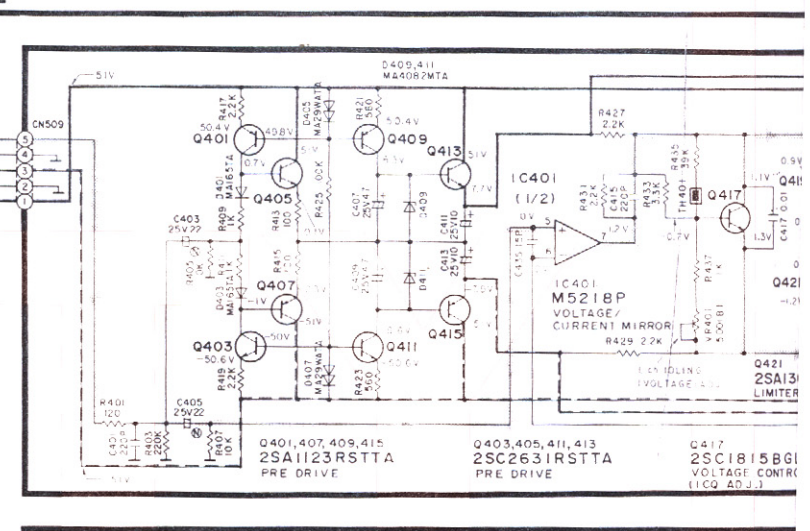
E OPERATION CIRCUIT**F** VOLUME CIRCUIT**G** VOLTAGE CONTROL AMP (L ch) CIRCUIT**H** VOLTAGE CONTROL AMP (R ch) CIRCUIT

F VOLUME CIRCUIT

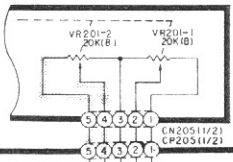

K HEADPHONES CIRCUIT

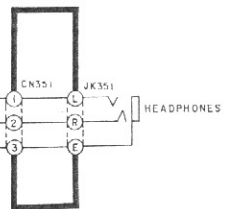

L RELAY/MUTING CIRCUIT

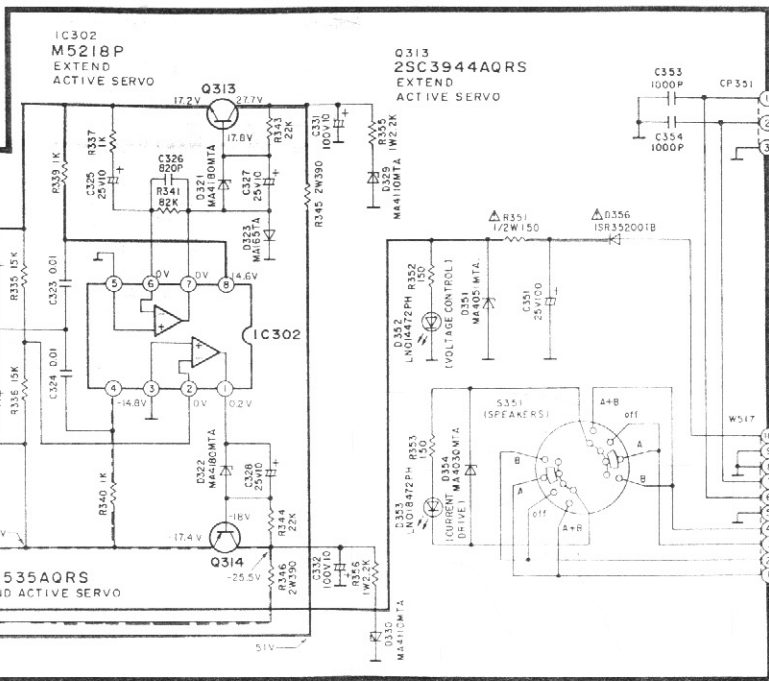
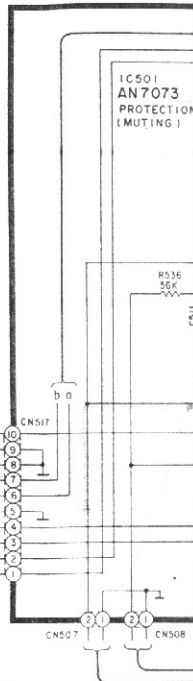

I POWER AMP(Lch) CIRCUIT

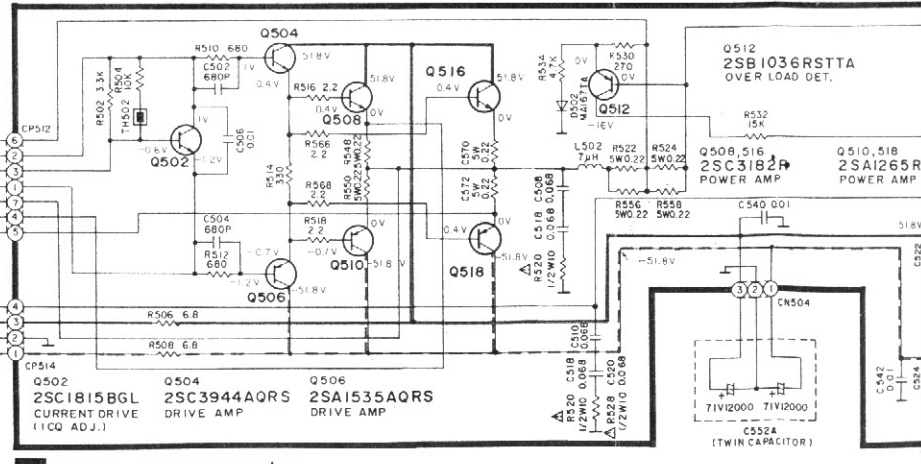
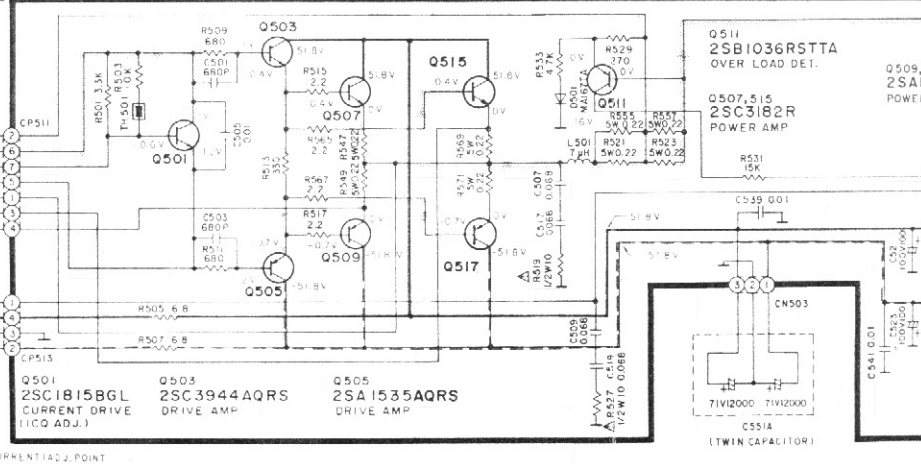
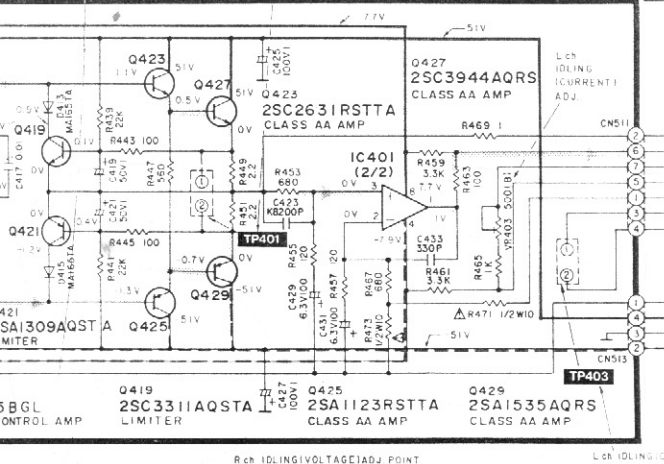

J POWER AMP(Rch) CIRCUIT

PHONES

UIT

HEADPHONES

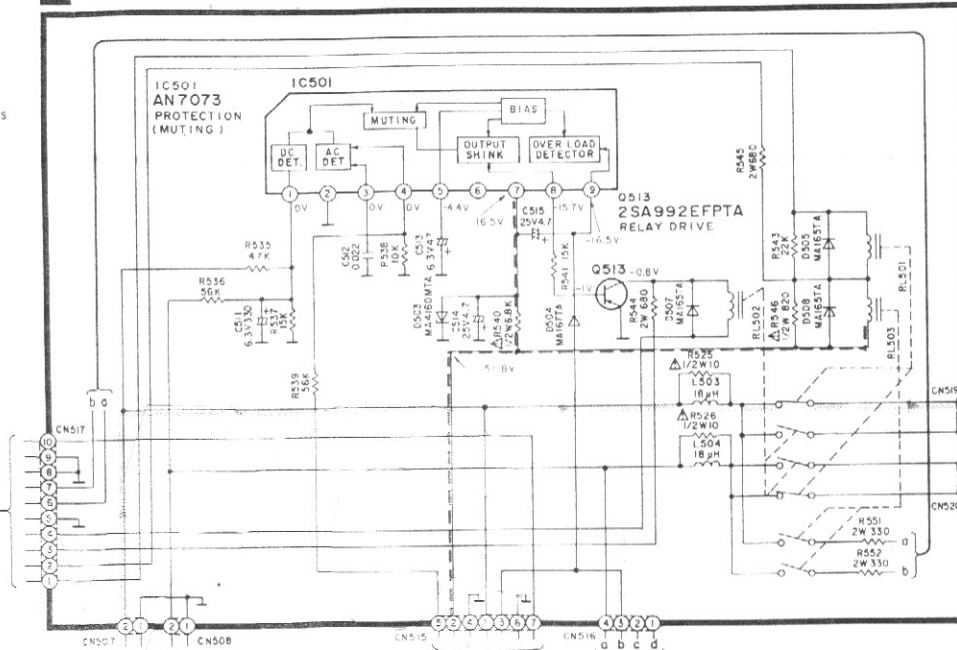
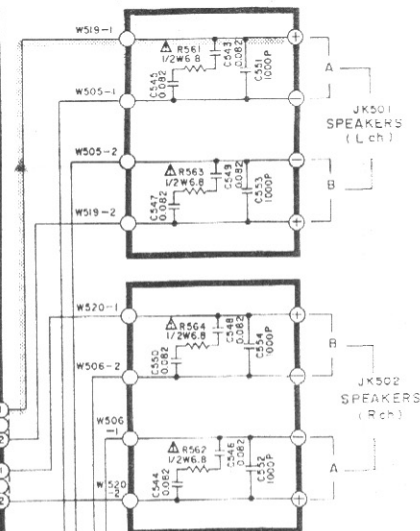
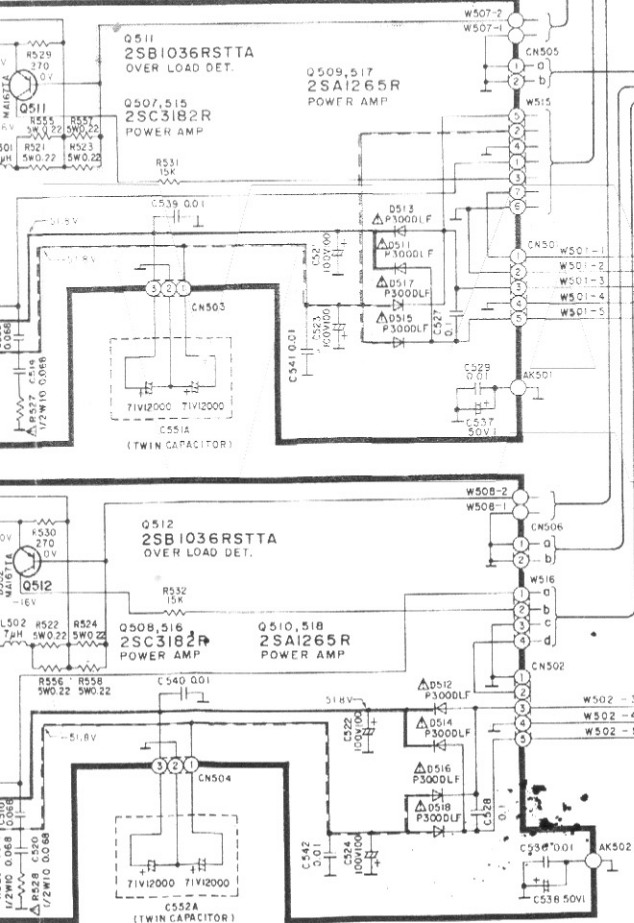
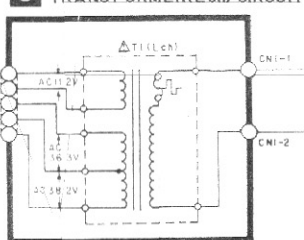
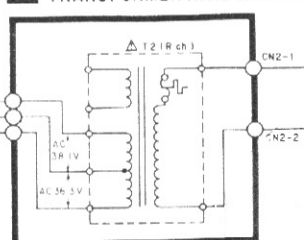
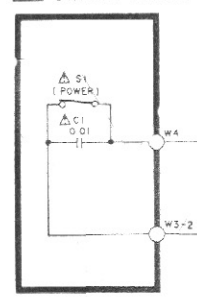
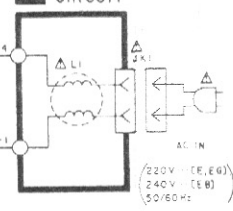
L RELAY/MUTING CIRCUIT**M** SPEAKER TERMINAL (L ch) CIRCUIT**N** SPEAKER TERMINAL (R ch) CIRCUIT**O** POWER TRANSFORMER (L ch) CIRCUIT**P** POWER TRANSFORMER (R ch) CIRCUIT**Q** POWER SWITCH CIRCUIT**R** FUSE CIRCUIT**S** AC IN CIRCUIT

AC IN
(220V - (E, E6)
240V - (E, E)
50/60Hz)

(1) VOLTAGE CONTROL (V) AMP. IDLING (ICQ) ADJUSTMENT

1. Test equipment connection is shown in figure. (Connect the DC EVM on both channels.)
2. Completely turn the (V) amp. adjusting volumes (VR401, VR402) counter-clockwise.
3. Turn ON the set when it is cold, and about 5 ~ 7 sec. later, adjust VR401 and VR402 so that the voltage is 25mV.
Also, check that the voltage is 25 ~ 30mV (standard: 27mV) after lapse of 10 ~ 15 minutes. (Below 50mV after lapse of 20min.).

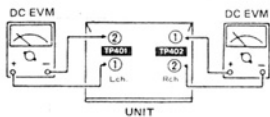

(2) CURRENT DRIVE (C) AMP. IDLING (ICQ) ADJUSTMENT

1. Test equipment connection is shown in figure. (Connect the DC EVM on both channels.)
2. Completely turn the (C) amp. adjusting volumes (VR403, VR404) counter-clockwise.
3. Turn ON the set when it is cold, and the "VOLTAGE CONTROL (V) AMP. IDLING (ICQ) ADJUSTMENT" later, adjust VR403 and VR404 so that the voltage is 3mV.
Also, check that the voltage is 4 ~ 7mV (standard: 5mV) after lapse of 10 ~ 15 minutes. (Below 15mV after lapse of 20 min.).

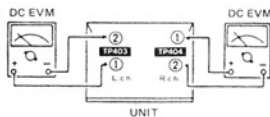

• Adjustment points

