

Service Manual

Stereo Integrated Amplifier

Amplifier

SU-V96

Color

(K)Black Type

Area

Color	Area
(K)	(PA)Far East PX.
(K)	(PE)European Military.

Please use this manual together with the service manual for Model No.SU-Z960, Order No.HAD8706157C8.

CHANGES

■ REPLACEMENT PARTS LIST

Note: Mentioned in this parts list are only those different from Model No.SU-Z960 (Black Type) for the destination (XA) area.

Ref.No.	Change of Part No.		Part Name&Description	Remarks
	SU-Z960 (XA)	→ SU-V96 (PA,PE)		
CABINET AND CHASSIS				
3	SGYUZ960-KE	SGYUV96-KM	Front Panel Ass'y	Change
34	SGP7111-1A	SGP7111-5A	Rear Panel	Change
51	SJJ141	-----	Jack,Socket	Deletion
CAPACITORS				
C703	ECES1JU682U	ECES71V103VN	Electrolytic , 71V , 10000 μ F	Change
C704	ECES1JU682U	ECES71V103VN	Electrolytic , 71V , 10000 μ F	Change
ACCESSORIES				
A2	SJP2257T	-----	Cord	Deletion
A5	SQF12951	SQF12955	Instruction Book	Change
A7	SWKUV96KM	SWKUV96KM5	Cord	Change
PACKING				
P1	SPG5983	SPG5985	Carton Box	Change

Technics

Matsushita Electric Trading Co., Ltd.
PO Box 288, Central Osaka Japan

Panasonic Tokyo Office
Matsushita Electric Trading Co., Ltd.
6th Floor, World Trade Center Bldg.,
No. 4-1, Hamamatsu-cho 2-Chome, Minato-ku,
Tokyo 105, Japan

Printed in Japan
K870600850 MT/AM

Service Manual

Stereo Integrated Amplifier

Amplifier

SU-Z960

Color

(K)Black Type

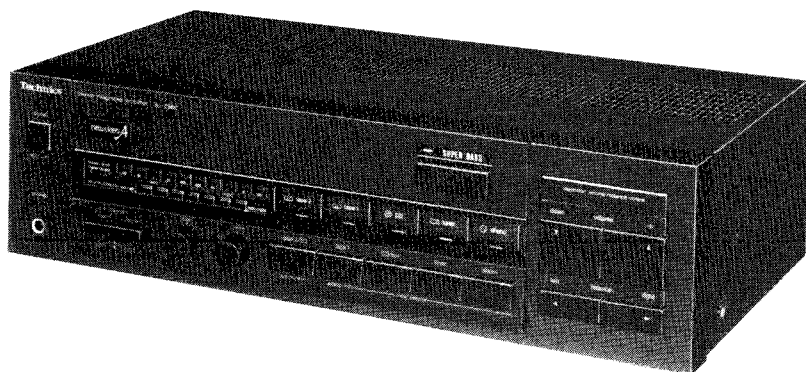

Area

Color	Area
(K)	(EX)Continental Europe.
(K)	(EW)Switzerland.
(K)	(EH)Holland.
(K)	(XL)Australia.
(K)	(XA)Asia, Latin America, Middle Near East, Africa and Oceania.
(K)	(EK)United Kingdom.
(K)	(EB)Belgium.
(K)	(EF)France.
(K)	(EG)F.R. Germany.
(K)	(Ei)Italy.

SPECIFICATIONS

(DIN 45 500)

■ AMPLIFIER SECTION

40 Hz ~ 20 kHz continuous power output both channels driven	2 x 85 W (8Ω)
DIN power output	2 x 100 W (8Ω)
Total harmonic distortion	
rated power at 40 Hz ~ 20 kHz	0.09% (8Ω)
rated power at 1 kHz	0.05% (8Ω)
half power at 1 kHz	0.03% (8Ω)
Intermodulation distortion	
rated power at 60 Hz:7 kHz = 4:1, SMPTE, 8Ω	0.09%
Power bandwidth	
both channels driven, -3dB	10 Hz ~ 20 kHz (8Ω, THD 0.09%)
Residual hum and noise	1 mV
Damping factor	50 (8Ω)
Input sensitivity and impedance	
PHONO	2.5mV/47 kΩ
TUNER, CD/AUX, TAPE 1, TAPE 2/EQ	150mV/33 kΩ
PHONO maximum input voltage (1 kHz, RMS)	140 mV
S/N	
rated power (8Ω)	
PHONO	71 dB (IHF, A: 78 dB)
TUNER, CD/AUX, TAPE 1, TAPE 2/EQ	70 dB (IHF, A: 90 dB)
Frequency response	
PHONO	RIAA standard curve ± 0.8dB (30 Hz ~ 15 kHz)
TUNER, CD/AUX, TAPE 1, TAPE 2/EQ	10 Hz ~ 60 kHz (-3 dB)
Tone controls	
BASS	50 Hz, + 10 dB ~ -10 dB
TREBLE	20 kHz, + 10 dB ~ -10 dB

Super bass	80 Hz, + 6 dB
Muting	-20dB
Output voltage	
TAPE 1, 2 REC OUT	150 mV
Channel balance, CD/AUX 250 Hz ~ 6,300 Hz	± 1 dB
Channel separation, AUX 1 kHz	50dB
Headphones output level and impedance	670 mV/330 Ω
Load impedance	
MAIN or REMOTE	8 Ω ~ 16 Ω
MAIN and REMOTE	8 Ω ~ 16 Ω

■ GENERAL

Power consumption	470 W
Power supply	
For United Kingdom and Australia	AC 50 Hz/60 Hz, 240 V
For continental Europe	AC 50 Hz/60 Hz, 220 V
For others	AC 50 Hz/60 Hz, 110 V/127 V/220 V/240 V
Dimensions (W x H x D)	430 x 119 x 240 mm (16-15/16" x 4-11/16" x 9-7/16")
Weight	7.0 kg (15.4 lb.)

Notes:

- Specifications are subject to change without notice. Weight and dimensions are approximate.
- Total harmonic distortion is measured by the digital spectrum analyzer (H.P. 3045 system).

Technics

Matsushita Electric Trading Co., Ltd.
P.O. Box 288, Central Osaka Japan

CONTENTS

	Page		Page
BEFORE REPAIR.....	2	RESISTORS AND CAPACITORS	11,12
PROTECTION CIRCUITRY	2	TERMINAL GUIDE OF	
ACCESSORIES	2	TRANSISTORS,DIODES AND IC'S.....	12
LOCATION OF CONTROLS	3	BLOCK DIAGRAM	13,14
DISASSEMBLY INSTRUCTIONS.....	4,5	CIRCUIT BOARDS AND WIRING	
TERMINAL FUNCTION OF LSI.....	6	CONNECTION DIAGRAM	15 ~ 18
EXPLODED VIEW.....	7,8	SCHEMATIC DIAGRAM.....	19 ~ 22
REPLACEMENT PARTS LIST	9,10		

BEFORE REPAIR

- (1) Turn off the power supply. Using a 10Ω, 5W resistor connect both ends of power supply capacitors(C703,C704,10000μF) in order to discharge the voltage.
- (2) Before turning the power supply on , after completion of repair , slowly apply the primary voltage by using a power supply voltage controller to make sure that the consumed current at 50Hz/60Hz in NO SIGNAL mode should be shown below with respect to supply voltage 110V/127V/220V/240V.

Power supply voltage	AC110V	AC127V	AC220V	AC240V
Consumed current 50/60Hz	300 ~ 500mA	270 ~ 470mA	100 ~ 300mA	80 ~ 280mA

PROTECTION CIRCUITRY

The protection circuitry may have operated if either of the following conditions is noticed:

- * No sound is heard when the power is switched ON.
- * Sound stops during a performance.

The function of this circuitry is to prevent circuitry damage if, for example, the positive and negative speaker connection wires are "shorted" , or if speaker systems with an impedance less than the indicated rated impedance of this unit are used.

If this occurs, follow the procedure outlined below:

1. Switch OFF the power.
2. Determine the cause of the problem and correct it.
3. Switch ON the power once again.

Note:

When the protection circuitry functions, the unit will not operate unless the power is first switched OFF and then ON again.

ACCESSORIES

- AC power supply cord 1
- SJA168-1 [XA]
- SJA173 [XL]
- SJA188 [EK]
- SJA187 [others]

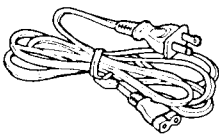

- Flat cable for remote-control operation 1
- SWKUV96KM



- Connection cable for remote-control operation 1
- SJP2257T

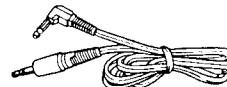

LOCATION OF CONTROLS

• Front panel

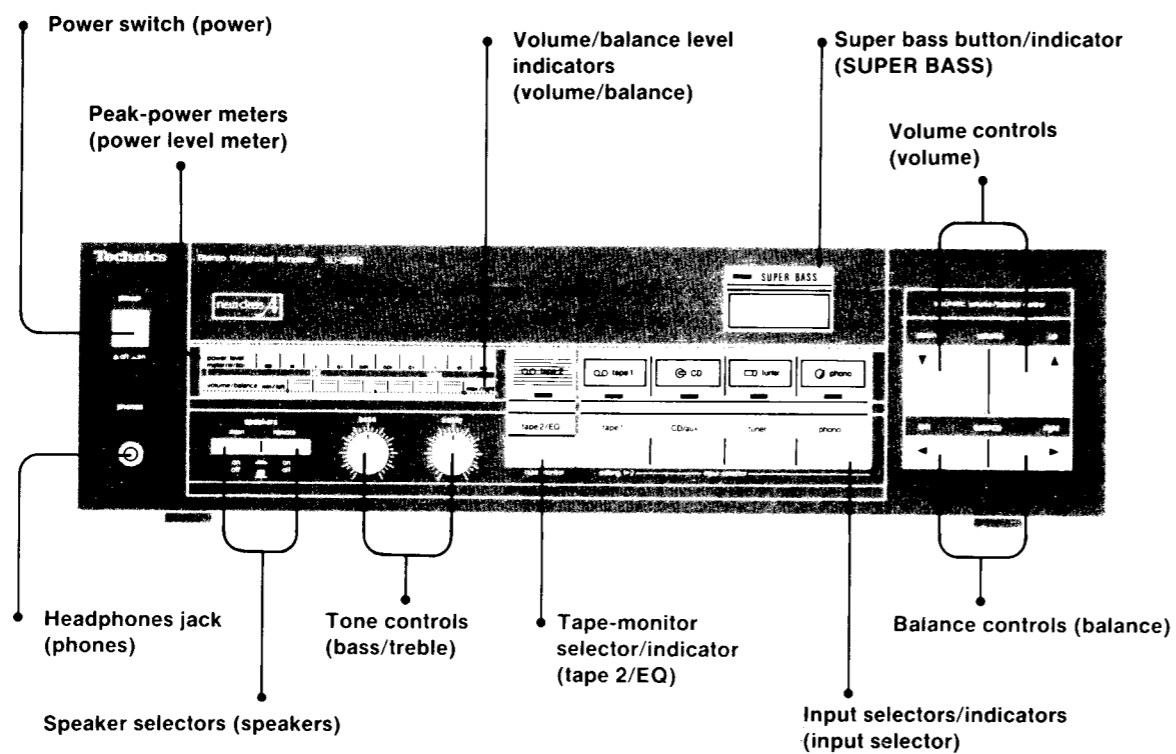

• Rear panel

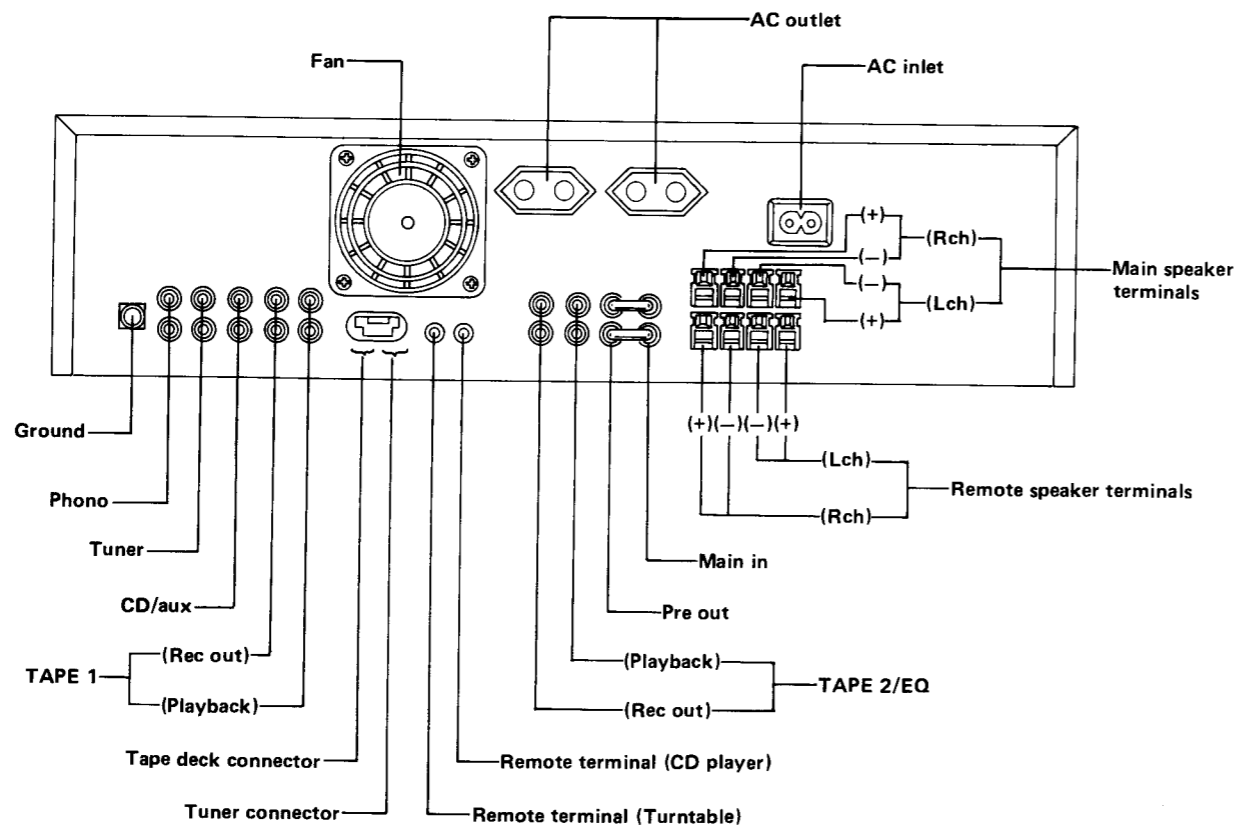

* Phono input capacitance is about 100pF.

DISASSEMBLY INSTRUCTIONS

Ref. No. 1	How to remove the front panel.
Procedure 1	1. Remove the top cabinet. 2. Pull out the 2 knobs (1, 2). 3. Remove the 3 screws (3 ~ 5).

"ATTENTION SERVICER"
SOME CHASSIS COMPONENTS MAY HAVE SHARP EDGES. BE CAREFUL WHEN DISASSEMBLING AND SERVICING.

Removing the knob
Wind cellophane tape around the knob and put it the direction of the arrow as shown in Fig. 1.

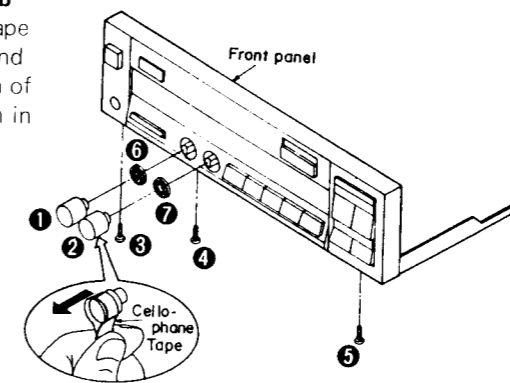

4. Remove the 2 nuts (6, 7)
5. Remove the connector.

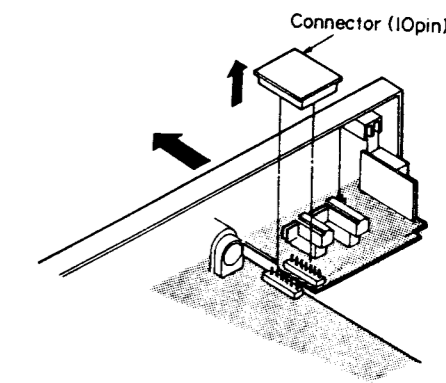

Ref. No. 2	How to remove the P.C.B.
Procedure 1 → 2	1. Remove the 7 screws (1 ~ 7). 2. Remove the LED P.C.B.

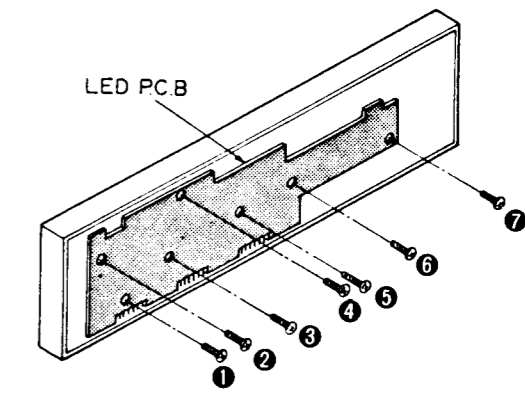

3. Remove the power switch knob.
4. Remove the 1 screw (8).
5. Remove the power switch P.C.B.

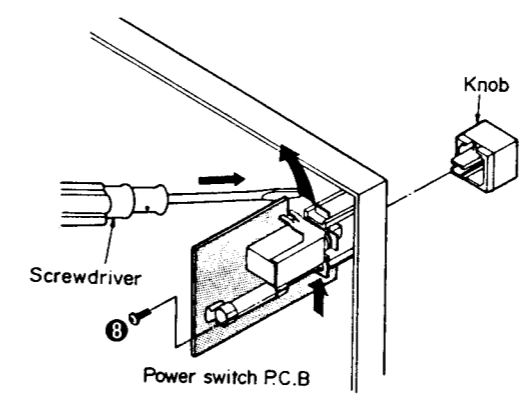

Remove the knob by pushing it from behind the panel as shown in Fig. 4.

6. Remove the 1 tab.
7. Remove the headphones P.C.B.

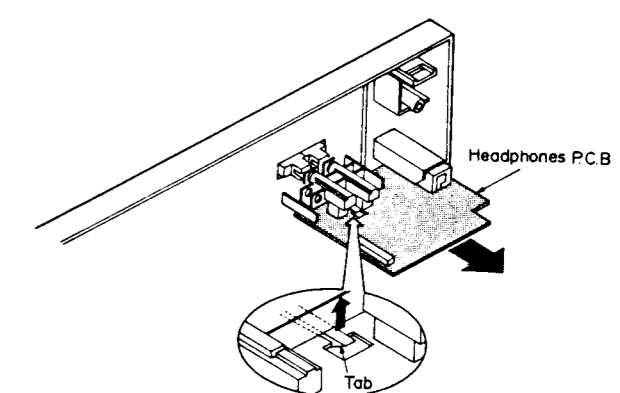

Ref. No. 3	How to remove the main P.C.B.
----------------------	--------------------------------------

Procedure 3	<ol style="list-style-type: none"> 1. Remove the 10 screws (❶ ~ ❿). 2. Remove the main P.C.B.
-----------------------	---

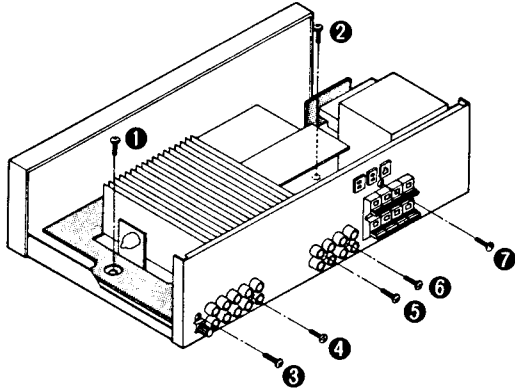

Fig. 6

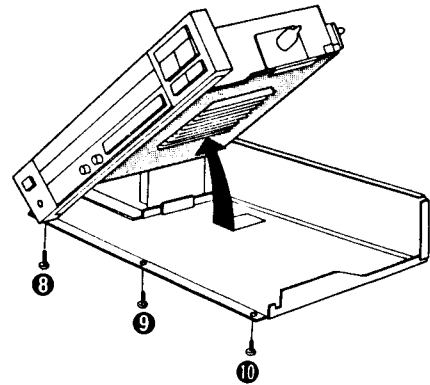

Fig. 7

Ref. No. 4	How to remove the power amplifier IC.
----------------------	--

Procedure 3 → 4	<ol style="list-style-type: none"> 1. Unsolder the power IC. 2. Remove the 2 screws (❶ , ❷). 3. Remove the sub heat-sink. 4. Remove the 2 screws (❸ , ❹).
---------------------------	---

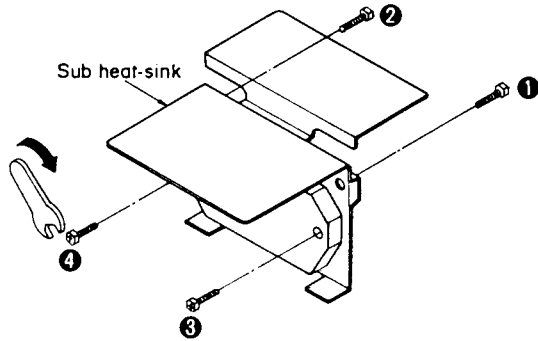

Fig. 8

- When mounting the power IC, apply silicon thermal compound (SZZOL15 or equivalent) to the rear of the power IC.

Ref. No. 5	How to remove the bottom board.
----------------------	--

Procedure 5	Remove the 11 screws (❶ ~ ❿).
-----------------------	---------------------------------

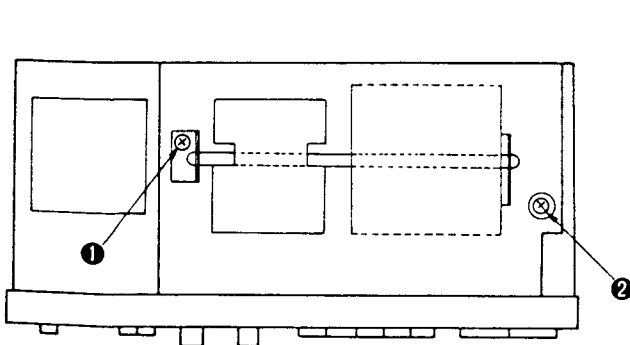

Fig. 9

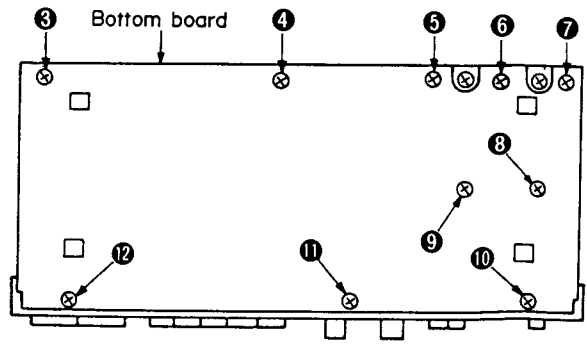

Fig. 10

■ TERMINAL FUNCTION OF LSI

● M50720-408SP (Micro-computer)

Pin No.	Mark	I/O	Function
1	S1	O	Key scan output
2	S2	O	Key scan output
3	REM	I	Remote control data input
4	OSC1	O	Clock oscillation output
5	OSC2	I	Clock oscillation input
6	ST	I	Program start input (hot start at "H")
7	RES	I	Reset signal input (reset at "L")
8	VDD	I	Power supply (connected to +5V)
9	NC	---	Not connected
10	REM	I	Remote control data input
11	NC	---	Not connected
12	DATA	O	Selector and volume control
13	CLK	O	Selector and volume control
14	STB	O	Selector and volume control
15	TAPE2	O	Tape 2 LED display
16	1	O	Volume level LED 1 display
17	2	O	Volume level LED 2 display
18	3	O	Volume level LED 3 display
19	4	O	Volume level LED 4 display
20	---	I	GND terminal
21	---	I	GND terminal
22	5	O	Volume level LED 5 display

Pin No.	Mark	I/O	Function
23	6	O	Volume level LED 6 display
24	7	O	Volume level LED 7 display
25	S.BASS	O	Super bass LED display and super bass control
26	PH	O	Phono LED display
27	TU	O	Tuner LED display
28	CD	O	CD/aux LED display
29	TAPE1	O	Tape 1 LED display
30	CS2	O	Aux 2 LED display
31	MUTE	I	Muting control
32	PWR	I	Power detection (power down mode at "L")
33	STOP	O	Turntable stop control
34	ST	O	Turntable start control
35	REC	I	Deck on-recording signal input
36	PLAY	I	Deck control signal input
37	DECK	O	Deck control signal output
38	K0	I	Key scan input
39	K1	I	Key scan input
40	K2	I	Key scan input
41	K3	I	Key scan input
42	S0	O	Key scan output

● TC9177P (Volume Control)

Pin No.	Mark	I/O	Function
1	VSS	I	Power supply (connected to -B)
2	---	I	Loudness terminal (not used)
3	---	O	Loudness terminal (not used)
4	OUT1	O	10 dB attenuator output
5	IN1	I	10 dB attenuator input
6	GND	I	GND terminal
7	IN2	I	2 dB attenuator input
8	OUT2	O	2 dB attenuator output
9	GND	I	GND terminal
10	CK	I	Clock input
11	DATA	I	Attenuation/channel select data input

Pin No.	Mark	I/O	Function
12	ST	I	Strobe input (attenuation/channel select data input)
13	OTT2	O	2 dB attenuator output
14	IN2	I	2 dB attenuator input
15	GND	I	GND terminal
16	IN1	I	10 dB attenuator input
17	OUT1	O	10 dB attenuator output
18	---	O	Loudness terminal (not used)
19	---	I	Loudness terminal (not used)
20	VDD	I	Power supply (connected to +B)

EXPLODED VIEW

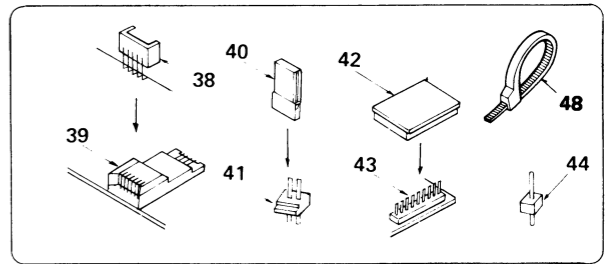
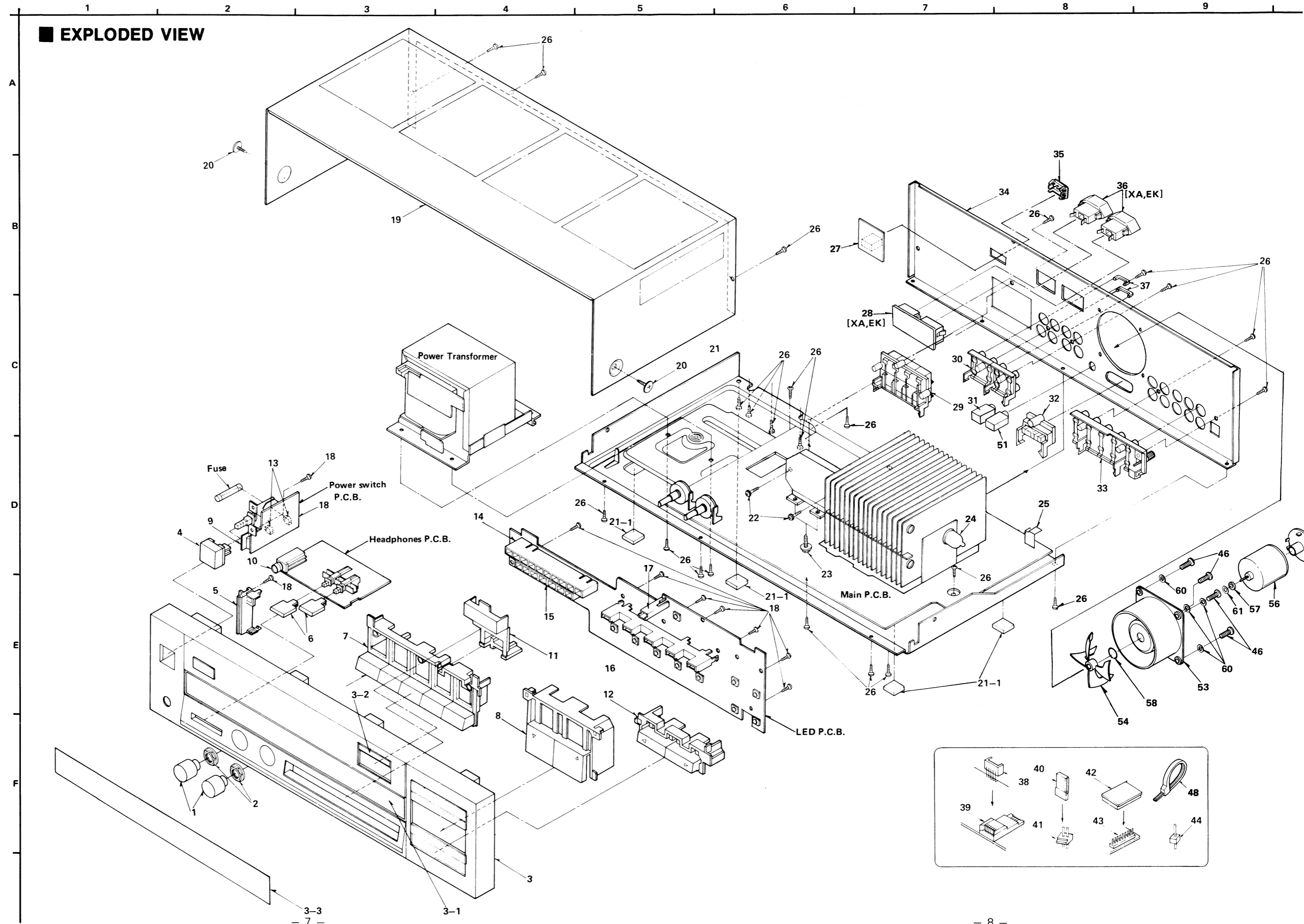

REPLACEMENT PARTS LIST

Notes: * Important safety notice:
Components identified by Δ mark have special characteristics important for safety. When replacing any of these components use only manufacturer's specified parts.

* Bracketed indications in Ref. No. columns specify the area.
Parts without these indications can be used for all areas.

Ref. No.	Part No.	Part Code	Description	Ref. No.	Part No.	Part Code	Description
CABINET AND CHASSIS				31	SJJ141-1	003 440 7804 8	M3 JACK
1	SBN1032-4	016 700 1857 9	KNOB, BASS.TREB	32	SJS604	003 403 4237 8	CONNECTOR
2	SNE4021	005 507 0372 5	NUT	33	SJF3062-1NK	003 410 8154 3	TERMINAL BOARD
3	SGYU2960KE	016 840 8098 5	FRONT PANEL	34	SGPUZ960-KE	016 840 8097 6	REAR PANEL
3-1	SDU329A	016 842 1631 4	FILTER	(EX, EH, EB)			
3-2	SGX7904A	016 846 3787 7	ORNAMENT, SUPER BASS	(EF, EI)			
3-3	SGU555A	016 842 1624 3	FILTER	34	SGP7111-1A	016 840 7989 3	REAR PANEL
4	SBC666-5	016 702 6679 9	BUTTON, POWER	(XA)			
5	SMP412	016 632 1789 3	ANGLE	34	SGP7111-2A	016 840 8190 0	REAR PANEL
6	SBC938	016 702 7019 5	BUTTON	(EK)			
7	SBC940	016 702 7031 9	BUTTON	34	SGP7111-3B	016 840 8219 4	REAR PANEL
8	SBC945A	016 702 7033 7	BUTTON	(EG)			
9	SMZ321	016 610 0033 6	OPTICAL SHIELD	34	SGP7111-3C	016 840 8218 5	REAR PANEL
(XL)				(EW)			
10	SJJ134B	003 400 7050 0	JACK, HEADPHONES	34	SGP7111-4A	016 840 8145 5	REAR PANEL
11	SBC939	016 702 7030 0	BUTTON	(XL)			
12	SBC946A	016 702 7029 3	BUTTON	35	SJS9231A	003 410 5984 5	AC INLET COVER
13	SJT388	003 410 6082 8	LUG TERMINAL	Δ			
(EK)				(EX, EW, EH)			
13	SJT390	003 410 7350 5	FUSE HOLDER	(XA, EK, EB)			
(XL)				(EF, EG, EI)			
14	LN108399P	001 033 0139 1	DIODE ASS-Y	35	SJS9234A	003 400 5921 6	AC INLET COVER
15	LN078328P	001 032 8674 6	DIODE ASS-Y	(XL)			
16	LN054398PH1	001 033 0136 4	DIODE ASS-Y	36	SJS9232A	003 410 5985 4	AC.Outlet COVER
17	LN018397PH	001 033 0129 3	DIODE ASS-Y	(XA)			
18	XTB3+8G	005 501 2607 7	SCREW	36	SJS9332A	003 403 7376 6	AC.Outlet COVER
19	SKC1950K992	016 800 2711 5	CABINET	(EK)			
20	SNE2129-1	005 500 7938 6	SCREW	37	SJP9205-2	003 492 6791 0	SHORTING PIN
21	SKUUV76-KM	016 802 2186 4	BOTTOM BOARD	38	SJT30647WL	003 410 8132 9	CONNECTOR
21-1	SKL293	016 828 0269 8	RUBBER	39	SJS50680WL	003 403 7235 8	CONNECTOR
22	SNE2118	005 500 5011 2	SCREW	41	SJT3209	003 410 1812 0	TERMINAL
23	XTW3+8T	005 501 1358 9	SCREW	42	SJS54-1	003 400 7801 5	JACK, SOCKET, (10P)
25	SMC6379	016 601 0538 7	SHIELD COVER	43	SJT3041	003 410 8161 4	TERMINAL BOARD
26	XTB3+8JFZ1	005 501 2523 0	SCREW	44	SJT3101	003 410 3704 5	CONNECTOR
27	Δ			45	XYN3+C10FZ	005 503 0894 4	SCREW
(EX, EW, EH)				(XA)			
(XA, EK, EB)				46	XTB3+10JFZ	005 501 4877 9	TAPPING SCREW
(EF, EG, EI)				47	SHE209	016 918 0588 5	PARTS KIT
27	Δ			(XA)			
(XL)				48	SHR301	016 645 0044 0	CLAMPER
28	Δ			49	SMX938	016 600 0539 1	SHIELD SPACER
(EX, EH, EB)				(XA)			
(EF, EI, EG)				50	SJT3213	003 410 6011 5	CONNECTOR
(EW)				51	SJJ141	003 400 7754 5	M3 JACK
(XA)				53	SMEZ960-KE		COVER, MOTOR
28	Δ			54	SHE174	016 950 0004 6	TOOL
(EK)				55	SME97-1	016 632 1309 1	ANGLE
29	SJF5812	003 410 8155 2	TERMINAL BOARD	56	MMN6C2RKMS	002 310 0999 3	DC MOTOR
30	SJF3066N	003 410 8130 1	TERMINAL BOARD	57	SDX323	016 756 0070 0	WHEEL
				58	SUS271	016 726 0357 6	SPRING
				60	SHG6267	016 653 0436 2	RUBBER
				61	SHW21S40	016 643 0998 9	WASHER

Ref. No.	Part No.	Part Code	Description	Ref. No.	Part No.	Part Code	Description	
PACKINGS				(EB, EF, EG)				
P1	SPG5983	016 971 5127 9	CARTON BOX	(EI)				
(EX, EW, EH)				A1	Δ	SJA188	003 490 5443 1	POWER CORD
(XL, XA, EK)				(EK)				
(EB, EG, EI)				A2		SJP2257T	003 492 6803 3	CORD
P1	SPG5984	016 971 5162 6	CARTON BOX	A3		UM-4NEP-2P	017 955 0003 4	PRIMARY BATTERY
(EF)				A4		SQF12950	016 983 5330 2	INSTRUCTION BOOK
P2	SPS4751-2	016 977 3361 9	PAD	(EX, EW, EB)				
P3	SPS4752-2	016 977 3362 8	PAD	A4		SQF12951	016 983 5381 1	INSTRUCTION BOOK
P4	SPS3987	016 977 1182 8	PAD	(XA, EK, EF)				
P5	SPP723	016 978 0207 5	PROTECTION COVER	A4		SQF12952	016 983 5382 0	INSTRUCTION BOOK
ACCESSORIES				(EG)				
A1	Δ			A4		SQF12954	016 983 5383 9	INSTRUCTION BOOK
(XA)				(EI)				
A1	Δ			A4		SQF13036	016 983 5380 2	INSTRUCTION BOOK
(XL)				(XL)				
A1	Δ			A7		SWKUV96KM	016 934 0170 5	WIRING MATERIAL
(EX, EW, EH)				A8	Δ	SJP9215	003 402 1437 9	AC PLUG ADAPTOR

Ref. No.	Part No.	Part Code	Description	Ref. No.	Part No.	Part Code	Description	
INTEGRATED CIRCUITS				VR301, VR302	EWCXE011C15	001 174 7737 1	V.R. BASS.TREB	
IC101	M5218L	001 060 3798 7	I.C., EQ AMP	COILS AND TRANSFORMERS				
IC201	TC9163N	001 061 0203 2	I.C., INPUT SELECTOR	L201, L202	ELEXHIROMA	001 211 4079 8	COIL	
IC202	TC9177P	001 061 0839 2	I.C., VOLUME CONTROL	L203, L204	ELEXH2R2MA	001 211 4080 5	COIL	
IC203	M50720-408SP	001 061 5760 8	I.C., MICRO COMPUTER	L281	ELEXT101KA	001 211 3878 9	COIL	
IC301, IC401	M5238L	001 061 3522 8	I.C., TONE AMP	L501, L502	SLQY07G-40	001 211 2149 9	CHOKE COIL	
IC501 Δ	SV13105B	001 061 4021 0	I.C., POWER AMP	T1	Δ	SLT5P277	001 202 9172 3	POWER TRANSFORMER
IC601, IC602	SV1BA6144	001 060 8320 1	I.C., POWER LEVEL METER	(EX, EW, EH)				
TRANSISTORS				(EB, EF, EG)				
Q207, Q208	2SK301	001 030 2428 2	TRANSISTOR	(EI)				
Q251, Q252	2SA1309Q	001 030 4058 0	TRANSISTOR	T1	Δ	SLT5P278	001 202 9194 7	POWER TRANSFORMER
Q253	2SA1309Q	001 030 4058 0	TRANSISTOR	(XL, EK)				
Q255	UN4111	001 030 2899 5	TRANSISTOR	T1	Δ	SLT5P279	001 202 9102 7	POWER TRANSFORMER
Q256	UN4115	001 030 4833 5	TRANSISTOR	(XA)				
Q257, Q258	2SK301	001 030 2428 2	TRANSISTOR	COMPONENT COMBINATIONS				
Q451, Q452	2SK301	001 030 2428 2	TRANSISTOR	ZZ51	EF0FC2004A4	001 242 0168 1	OSCILLATOR	
Q453	UN4115	001 030 4833 5	TRANSISTOR	LAMPS				
Q651	2SA992E	001 030 0513 4	TRANSISTOR	PL701	XAMS6Q17C	002 351 1074 6	PILOT LAMP	
Q721	2SD1265-0	001 030 2652 6	TRANSISTOR	(XL)				
Q761	2SC3311A-Q	001 030 5279 5	TRANSISTOR	FUSES				
Q762	2SA1309Q	001 030 4058 0	TRANSISTOR	F1	Δ	XBA2C20TB0	002 380 1352 0	FUSE 250V, T2A, T2A250V
DIODES				(EK)				
D201, D202	MA165	001 032 0494 0	DIODE	F1	Δ	XBAS2A2001	002 380 0410 1	FUSE, T2A250V
D203, D251	MA165	001 032 0494 0	DIODE	(EX, EW, EH)				
D252, D253	MA165	001 032 0494 0	DIODE	(XL, XA, EB)				
D255	MA165	001 032 0494 0	DIODE	(EF, EG, EI)				
D257	LN054398PH1	001 033 0136 4	DIODE ASS-Y	F2	Δ	XBA2C20TB0	002 380 1352 0	FUSE T2A250V
D258	MA165	001 032 0494 0	DIODE	(EW, EG)				
D258-, D264	LN078328P	001 032 8674 6	DIODE ASS-Y	F2	Δ	XBA2C40TR0	002 380 0417 4	FUSE, T4A250V
D265	LN018397PH	001 033 0129 3	DIODE ASS-Y	(XA)				
D266, D268	LN054398PH1	001 033 0136 4	DIODE ASS-Y	F3, 4	Δ	XBA2C05TB0	002 380 1350 2	FUSE, T0.5A 250V
D270	LN054398PH1	001 033 0136 4	DIODE ASS-Y	(EK)				
D282	MA165	001 032 0494 0	DIODE	SWITCHES				
D551	MA4240H	001 032 7227 9	DIODE	S1, S2	EVQQAC05G	003 439 2072 1	SWITCH, VOL	
D601-, D610	LN108399P	001 033 0139 1	DIODE ASS-Y	S3, S4	EVQQAC05G	003 439 2072 1	SWITCH, BAL(R/L)	
D701, D702 Δ	SVDS3V40	001 032 1347 6	RECTIFIER	S5, S6	EVQQAC05G	003 439 2072 1	SWITCH	
D703, D704 Δ	SVDS3V40	001 032 1347 6	RECTIFIER	S7, S8	EVQQAC05G	003 439 2072 1	SWITCH, TAPE1/CD	
D705, D706	MA4130M	001 032 4960 9	DIODE	S9, S10	EVQQAC05G	003 439 2072 1	SWITCH, TUN/PHONO	
D711, D721 Δ	SVD1SR35200A	001 032 3951 7	RECTIFIER	S13, S14	SSH2127	003 435 6328 0	SW, SPEAKER	
D722	MA4062-M	001 032 7211 7	DIODE	S15	Δ	ESB8249V	003 435 5877 0	POWER SWITCH
D731, D761	MA165	001 032 0494 0	DIODE	(XL)				
D762	MA4082M	001 032 4955 6	DIODE	RELAYS				
VARIABLE RESISTORS				RY551	SSY126	003 450 2686 0	RELAY	

RESISTORS & CAPACITORS

Notes: * Important safety notice:
 Components identified by Δ mark have special characteristics important for safety. When replacing any of these components use only manufacturer's specified parts.
 * Bracketed indications in Ref. No. columns specify the area.
 Parts without these indications can be used for all areas.

Numbering System of Resistor

Example

ERD	25	F	J	102
Type	Wattage	Shape	Tolerance	Value
ERX	2	AN	J	471
Type	Wattage	Shape	Tolerance	Value
				47x10 ¹ (ohm)

Numbering System of Capacitor

Example

ECKD	1H	102	Z	F
Type	Voltage	Value	Tolerance	Peculiarity
ECEA	50	M		330
Type	Voltage	Peculiarity		Value
				(33x10 ⁰ microfarad)

Resistor Type	Wattage	Tolerance
ERD : Carbon	10 : 1/8W	J : ±5%
ERG : Metal Oxide	12 : 1/2W	F : ±1%
ERX : Metal Film	25 : 1/4W	G : ±2%
ERQ : Fuse Type Metal	1A : 1W	K : ±10%
ERD [] L : Carbon (chip)	18 : 1/8W	
ERD [] K : Metal Film (chip)	S2 : 1/4W	
ERC : Solid	S1 : 1/2W	
	2F : 1/4W	
	50 : 1/2W	
	2A : 2W	

Capacitor Type	Voltage	Tolerance
ECE : Electrolytic	0J : 6.3V	C : ±0.25pF
ECCD : Ceramic	1A : 10V	J : ±5%
ECKD : Ceramic	1C : 16V	K : ±10%
ECQM : Polyester	1E : 25V	Z : +80%
	1H : 50V	-20%
ECQP : Polypropylene	1V : 35V	P : +100%
	50 : 50V	-0%
ECG : Ceramic	05 : 50V	M : ±20%
ECEADDN : Non Polar Electrolytic	2H : 500V	
QCU [] : Ceramic (Chip Type)	2A : 100V	D : ±0.5pF
ECUX : Ceramic (Chip Type)	1 : 100V	G : ±2%
ECF : Semiconductor	KC : 400V AC	
	KC : 125VAC (UL)	
EECW : Liquid electrolyte double layer capacitor	1J : 63V	

Ref. No.	Part No.	Part Code	Ref. No.	Part No.	Part Code	Ref. No.	Part No.	Part Code
C256, C257	ECBT1H102KB5	001 103 8123 8	C411	ECKD1H473ZF	001 103 5404 4	C560	ECEAJK470	001 120 0143 9
C287, C288	ECBT1H102KB5	001 103 8123 8	C413, C414	ECEA1HK010	001 120 0341 5	C601, C602	ECKD1H103PF	001 103 1449 7
C289	ECBT1H102KB5	001 103 8123 8	C501, C502	ECEA1EN4R7S	001 120 0299 0	C603, C604	ECEA1CKS100	001 120 2600 7
C291	ECKD1H102PF	001 103 1435 3	C503, C504	ECKD1H331KB	001 103 1523 4	C701	ECKWNS103ZV	001 103 8209 3
C301, C302	ECCD1H150KC	001 103 0410 6	C505, C506	ECKD1H471KB	001 103 1551 0	C702	(XL)	
C303, C304	ECKD1H221KB	001 103 1487 1	C507, C508	ECEA1CNS30S	001 120 0240 9	C702	ECKD2H103PE	001 103 1626 8
C305, C306	ECCD1H100KC	001 103 0321 6	C509, C510	ECCD1H150KC	001 103 0410 6	C702	(XL, XA, EK)	
C307, C308	ECEA1CKS100	001 120 2600 7	C511, C512	ECQM1H473JZ	001 106 0810 9	C702	ECQP1224JZW	001 106 5500 0
C309, C310	ECFTD123KXL	001 108 0745 1	C521, C522	ECKD1H473ZF	001 103 5404 4	C702	(EX, EW, EB)	
C311, C312	ECFTD683KXL	001 108 0346 2	(EG)			C702	(EF, EG, E1)	
C313, C314	ECFTD562KXL	001 108 0904 4	C523, C524	ECKD1H473ZF	001 103 5404 4	C703, C704	ECES1JU682U	001 120 5966 8
C315, C316	ECFTD273KXL	001 108 0343 5	(EG)			C707, C708	ECKD1H103PF	001 103 1449 7
C317	ECKD1H103PF	001 103 1449 7	C525, C526	ECKD1H221KB	001 103 1487 1	C711	ECEA1CU471	001 120 3202 3
C401, C402	ECFTD104KXL	001 108 0793 3	(EG)			C721	ECEA16V1000	001 120 2545 7
C403, C404	ECFTD104KXL	001 108 0793 3	C551	ECEAJU101	001 120 2829 8	C722, C724	ECKD1H103PF	001 103 1449 7
C405, C406	ECKD1H103PF	001 103 1449 7	C552	ECEA1HS330	001 120 0383 5	C731	ECEA1HK010	001 120 0341 5
C409, C410	ECEA1HKR47	001 120 0338 0	C553	ECQM1H224JZ	001 106 0746 0	C761	ECEA1CKS100	001 120 2600 7

Ref. No.	Part No.	Part Code	Ref. No.	Part No.	Part Code	Ref. No.	Part No.	Part Code
RESISTORS								
R101, R102	ERDS2TJ391	001 152 2360 6	R277, R278	ERDS2TJ103	001 152 2347 3	R605, R606	ERDS2TJ103	001 152 2347 3
R103, R104	ERDS2TJ473	001 152 2363 3	R279, R289	ERDS2TJ103	001 152 2347 3	R607, R608	ERDS2TJ330	001 152 2355 3
R105, R106	ERDS2TJ271	001 152 2435 4	R290	ERDS2TJ473	001 152 2363 3	R609, R610	ERDS2TJ330	001 152 2355 3
R107, R108	ERDS2TJ123	001 152 2424 7	R291	ERDS2TJ103	001 152 2347 3	R701, R702	ERG3ANJ102	001 151 0211 1
R109, R110	ERDS2TJ184	001 152 2588 8	R292, R293	ERDS2TJ683	001 152 2450 5	R703	ERDS1FJ271	001 152 2624 1
R111, R112	ERDS2TJ184	001 152 2588 8	R293	ERDS2TJ103	001 152 2347 3	R704	ERDS1FJ221	001 152 2513 7
R113, R114	ERDS2TJ391	001 152 2360 6	R294, R295	ERDS2TJ472	001 152 2362 4	R722, R731	ERDS2TJ102	001 152 2346 4
R121, R122	ERDS2TJ471	001 152 2361 5	R301, R302	ERDS2TJ103	001 152 2347 3	R732, R733	ERDS2TJ273	001 152 2436 3
R203, R204	ERDS2TJ563	001 152 2446 1	R303, R304	ERDS2TJ474	001 152 2443 4	R734	ERDS2TJ124	001 152 2426 6
R205	ERDS2TJ563	001 152 2446 1	R305, R306	ERDS2TJ392	001 152 2439 0	R761, R762	ERDS2TJ223	001 152 2432 7
R206	ERDS2TJ474	001 152 2443 4	R307, R308	ERDS2TJ392	001 152 2439 0	R763, R764	ERDS2TJ223	001 152 2432 7
R207, R208	ERDS2TJ103	001 152 2347 3	R309, R310	ERDS2TJ183	001 152 2429 2	R765	ERDS2TJ392	001 152 2439 0
R209, R210	ERDS2TJ102	001 152 2346 4	R311, R312	ERDS2TJ332	001 152 2357 1	CAPACITORS		
R211, R212	ERDS2TJ102	001 152 2346 4	R313, R314	ERDS2TJ122	001 152 2423 8	C101, C102	ECCD1H101K	001 103 0341 2
R213, R214	ERDS2TJ102	001 152 2346 4	R315, R316	ERDS2TJ821	001 152 2454 1	C103, C104	ECKD1H102PF	001 103 1435 3
R215, R216	ERDS2TJ102	001 152 2346 4	R317, R318	ERDS2TJ223	001 152 2432 7	C105, C106	ECEAJK330	001 120 0141 1
R223, R224	ERDS2TJ333	001 152 2358 0	R321, R322	ERDS2TJ222	001 152 2353 5	C107, C108	ECFTD682KXL	001 108 0363 1
R225, R226	ERDS2TJ103	001 152 2347 3	R401, R402	ERDS2TJ471	001 152 2361 5	C109, C110	ECFTD223KXL	001 108 0342 6
R227	ERDS2TJ103	001 152 2347 3	R403, R404	ERDS2TJ563	001 152 2446 1	C111, C112	ECEA1HK010	001 120 0341 5
R230	ERDS2TJ124	001 152 2425 6	R405, R406	ERDS2TJ682	001 152 2365 1	C113, C114	ECEA1CKS100	001 120 2600 7
R231	ERDS2TJ472	001 152 2362 4	R407, R408	ERDS2TJ102	001 152 2346 4	C115	ECKD1H103PF	001 103 1449 7
R251	ERDS2TJ103	001 152 2347 3	R409, R410	ERDS2TJ224	001 152 2433 6	C121, C122	ECCD1H180KC	001 103 0448 2
R252	ERDS2TJ105	001 152 2422 9	R411	ERDS2TJ563	001 152 2446 1	C123, C124	ECCD1H151K	001 103 0429 5
R253, R254	ERDS2TJ103	001 152 2347 3	R415, R416	ERDS2TJ824	001 152 2457 8	(EG)		
R255	ERDS2TJ104	001 152 2348 2	R417, R418	ERDS2TJ102	001 152 2346 4	C201	ECKD1H103PF	001 103 1449 7
R257, R258	ERDS2TJ682	001 152 2365 1	R452	ERDS2TJ224	001 152 2433 6	C209, C210	ECCD1H101K	001 103 0341 2
R259	ERDS2TJ682	001 152 2365 1	R453	ERDS2TJ563	001 152 2446 1	(EG)		
R260	ERDS2TJ151	001 152 2426 5	R501, R502	ERDS2TJ102	001 152 2346 4	C211, C212	ECCD1H101K	001 103 0341 2
R261, R262	ERDS2TJ221	001 152 2431 8	R503, R504	ERDS2TJ393	001 152 2440 7	(EG)		
R263, R264	ERDS2TJ221	001 152 2431 8	R505, R506	ERDS2TJ272	001 152 2354 4	C213, C214	ECCD1H101K	001 103 0341 2
R265, R266	ERDS2TJ221	001 152 2431 8	R507, R508	ERDS2TJ393	001 152 2440 7	(EG)		
R267, R268	ERDS2TJ221	001 152 2431 8	R509, R510	ERD25FJ4R7	001 152 0303 3	C215, C216	ECCD1H101K	001 103 0341 2
R269, R270	ERDS2TJ151	001 152 2426 5	R511, R512	ERDS2TJ100	001 152 2420 1	(EG)		
R271	ERDS2TJ151	001 152 2426 5	R513, R514	ERG2ANJ331	001 151 0154 3	C225	ECKD1H223PF	001 103 1510 9
R273	ERDS2TJ121	001 152 2349 1	R520	ERD25FJ470	001 152 0309 7	C226	ECKD1H473ZF	001 103 5404 4
R274, R276	ERDS2TJ103	001 152 2347 3	R551	ERDS2TJ473	001 152 2363 3	C231	ECKD1H103PF	001 103 1449 7
			R552	ERDS2TJ123	001 152 2424 7	C251	ECEA1HN2R2S	001 120 0356 8
			R553 Δ	ERG2ANJ152	001 151 0130 1	C252	EECF5R5U473	001 120 3738 6
			R554	ERDS1FJ472	001 152 2634 9	C253	ECEAJU101	001 120 2829 8
			R556	ERDS2TJ154	001 152 2427 4	C254	ECKD1H223PF	001 103 1510 9
			R601, R602	ERDS2TJ474	001 152 2443 4	C255	ECEA1HK010	001 120 0341 5
			R603, R604	ERDS2TJ103	001 152 2347 3			

TERMINAL GUIDE OF TRANSISTORS, DIODES AND ICS

<p>M50720408SP 42Pin TC9163N 28Pin TC9177P 20Pin</p>	<p>2SA1309Q 2SC3311A</p>	<p>UN4111</p>	<p>UN4115</p>
<p>SVD1SR35200A MA165 SVD53V20</p>	<p>MA4082M MA4062M MA4130M MA4240M</p>	<p>LN108399P LN018397PH LN054398PH1 LN078328P</p>	<p>SVI3105B 18Pin</p>
<p>SV1BA6144</p>	<p>2SA992E</p>	<p>2SK301</p>	<p>2SD1265-0</p>

BLOCK DIAGRAM

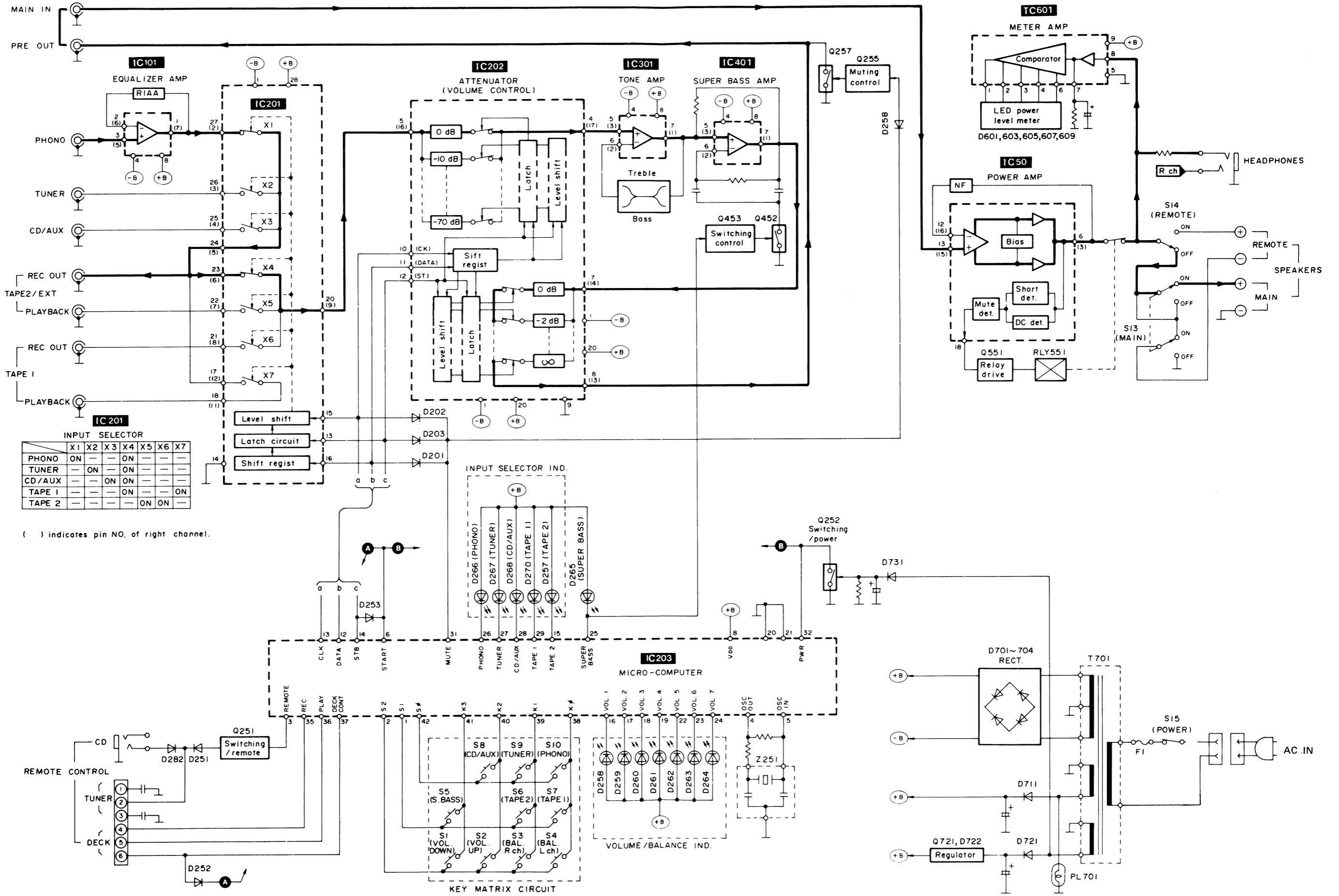

() indicates pin NO. of right channel.

CIRCUIT BOARDS AND WIRING CONNECTION DIAGRAM

A
B
C
D
E
F

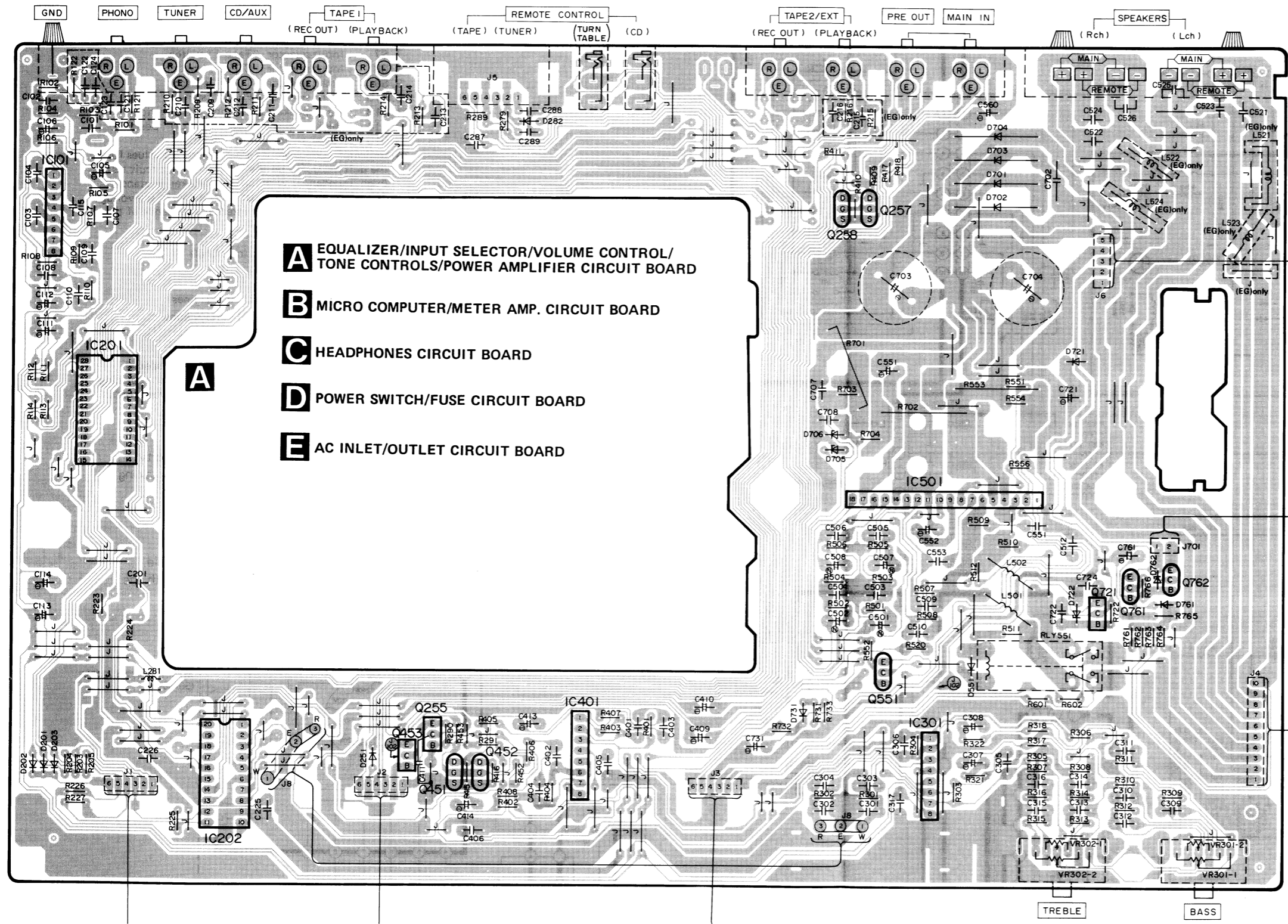

- A** EQUALIZER/INPUT SELECTOR/VOLUME CONTROL/TONE CONTROLS/POWER AMPLIFIER CIRCUIT BOARD
- B** MICRO COMPUTER/METER AMP. CIRCUIT BOARD
- C** HEADPHONES CIRCUIT BOARD
- D** POWER SWITCH/FUSE CIRCUIT BOARD
- E** AC INLET/OUTLET CIRCUIT BOARD

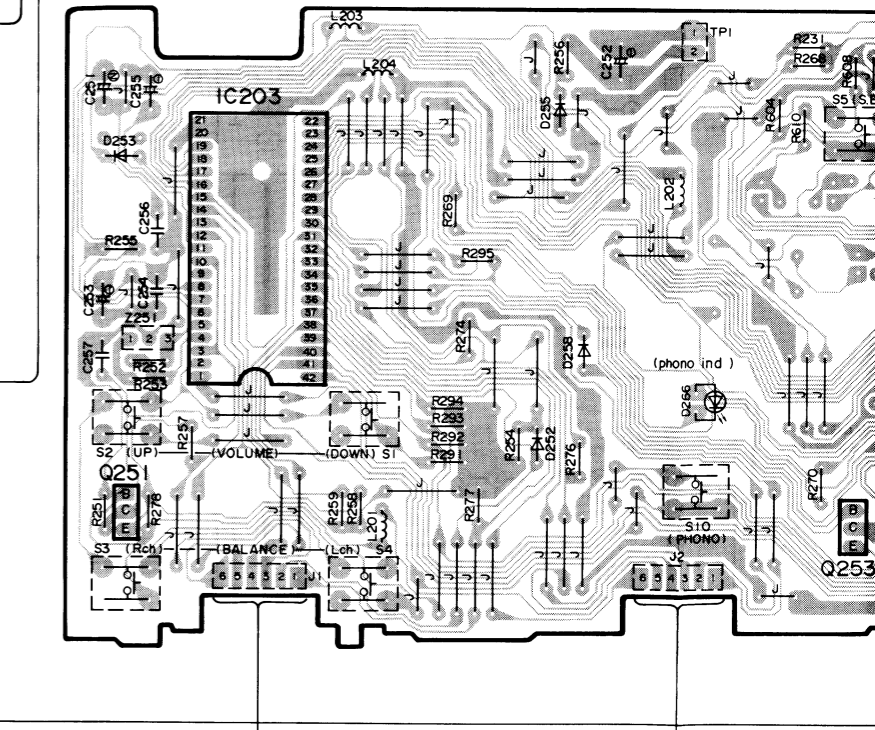
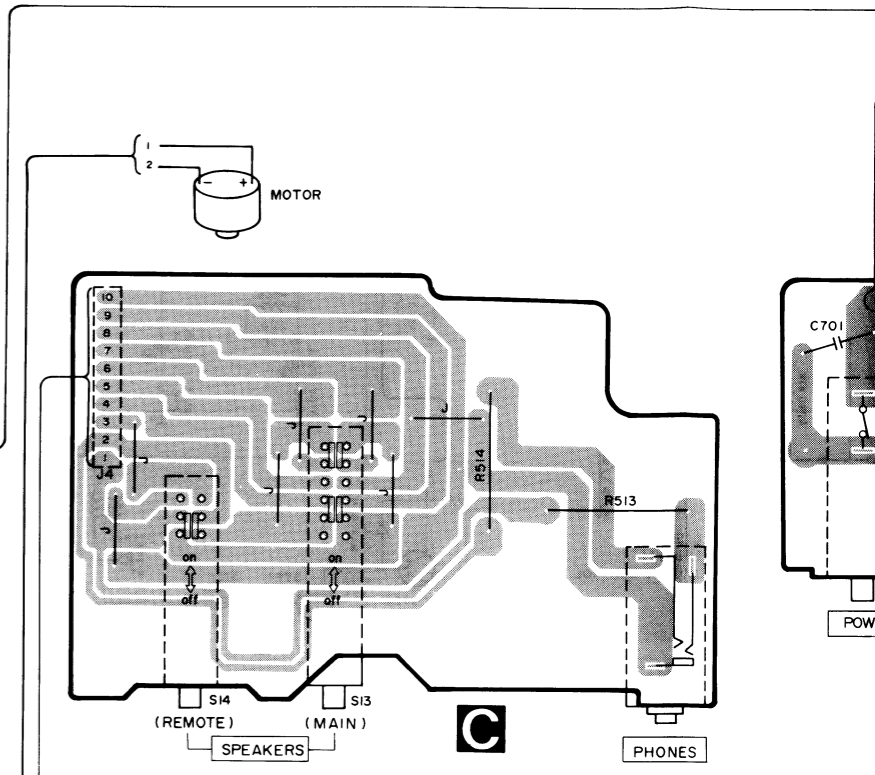

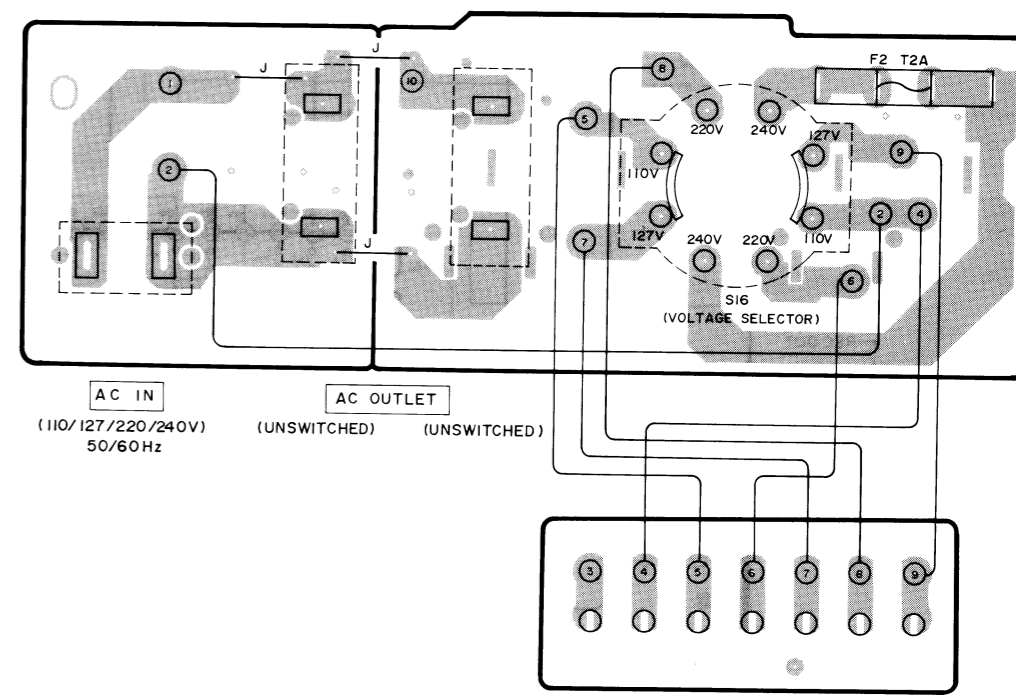
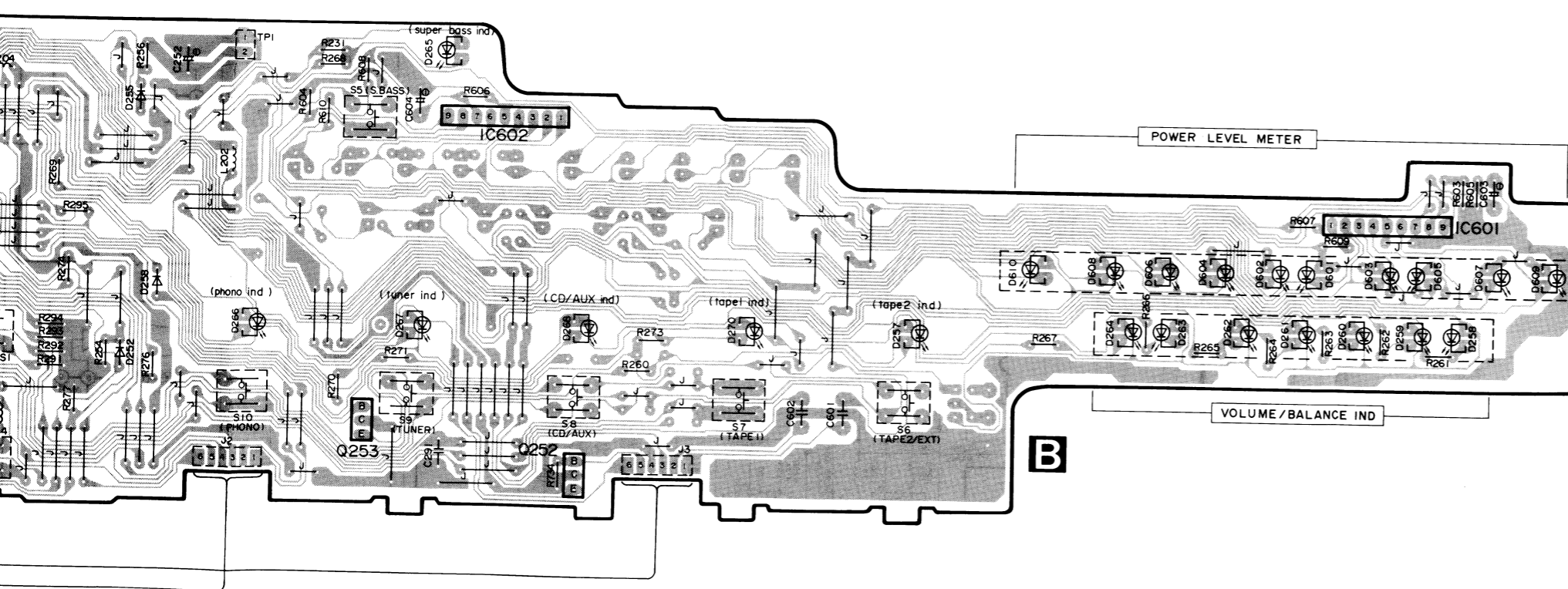
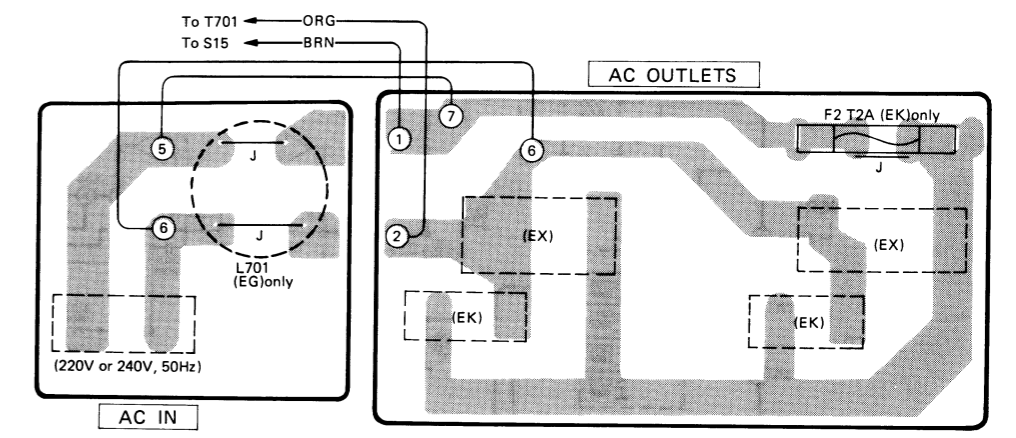
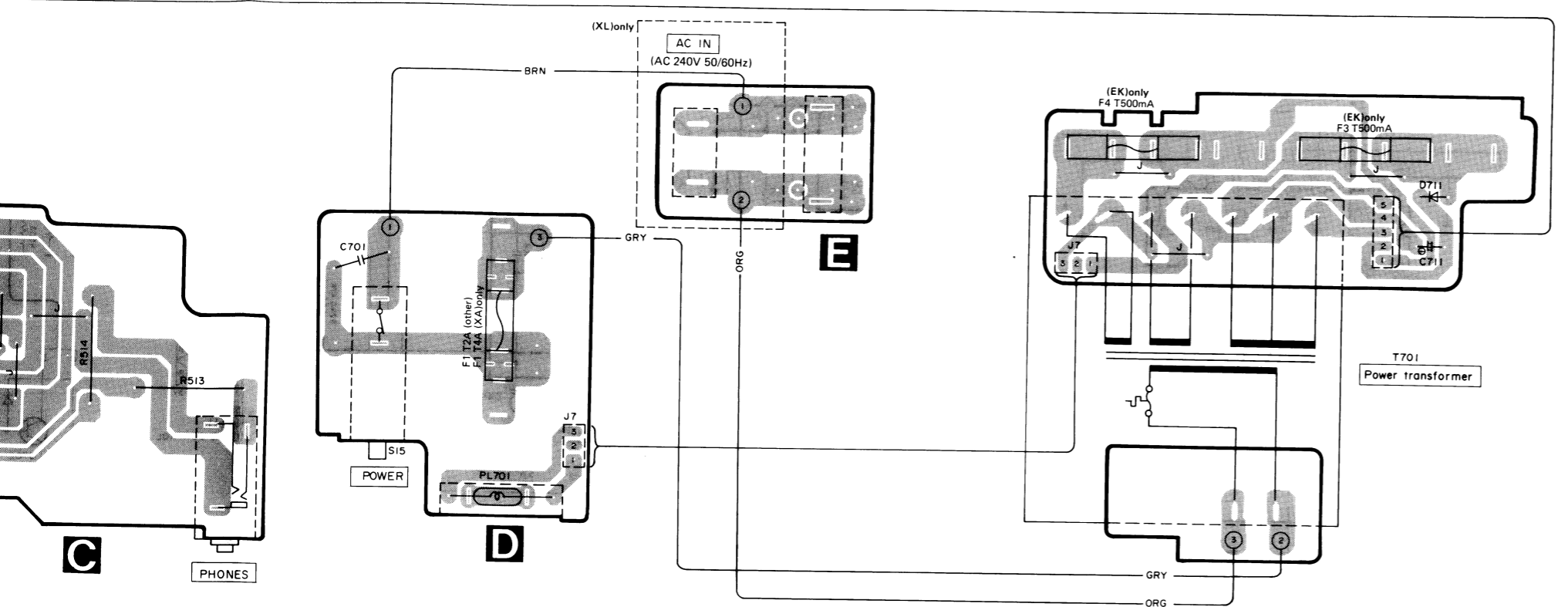

SCHEMATIC DIAGRAM

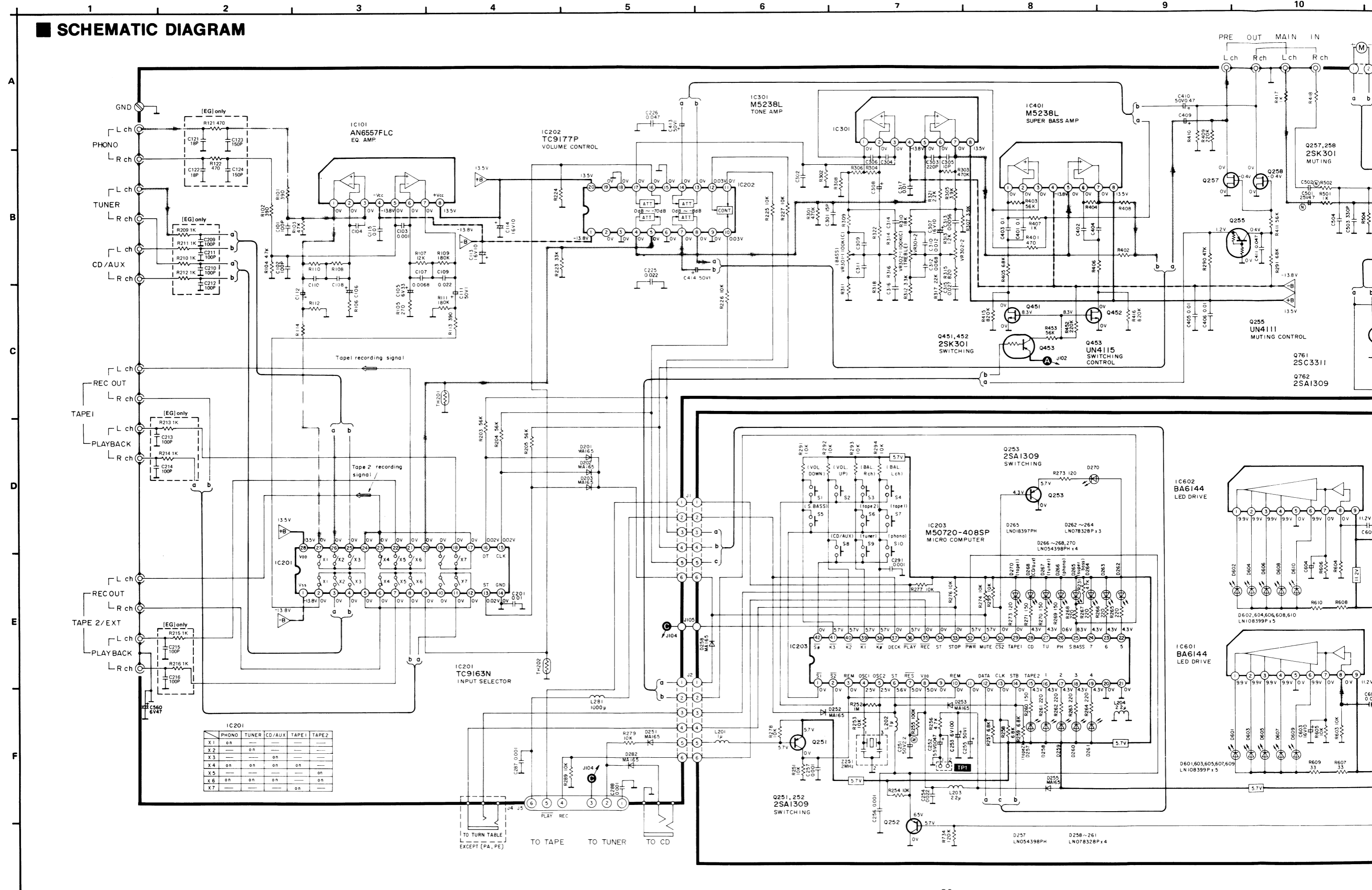

IC201

	PHONO	TUNER	CD/AUX	TAPE 1	TAPE 2
X1	on				
X2		on			
X3			on		
X4	on	on	on	on	
X5				on	on
X6	on	on	on	on	on
X7				on	on

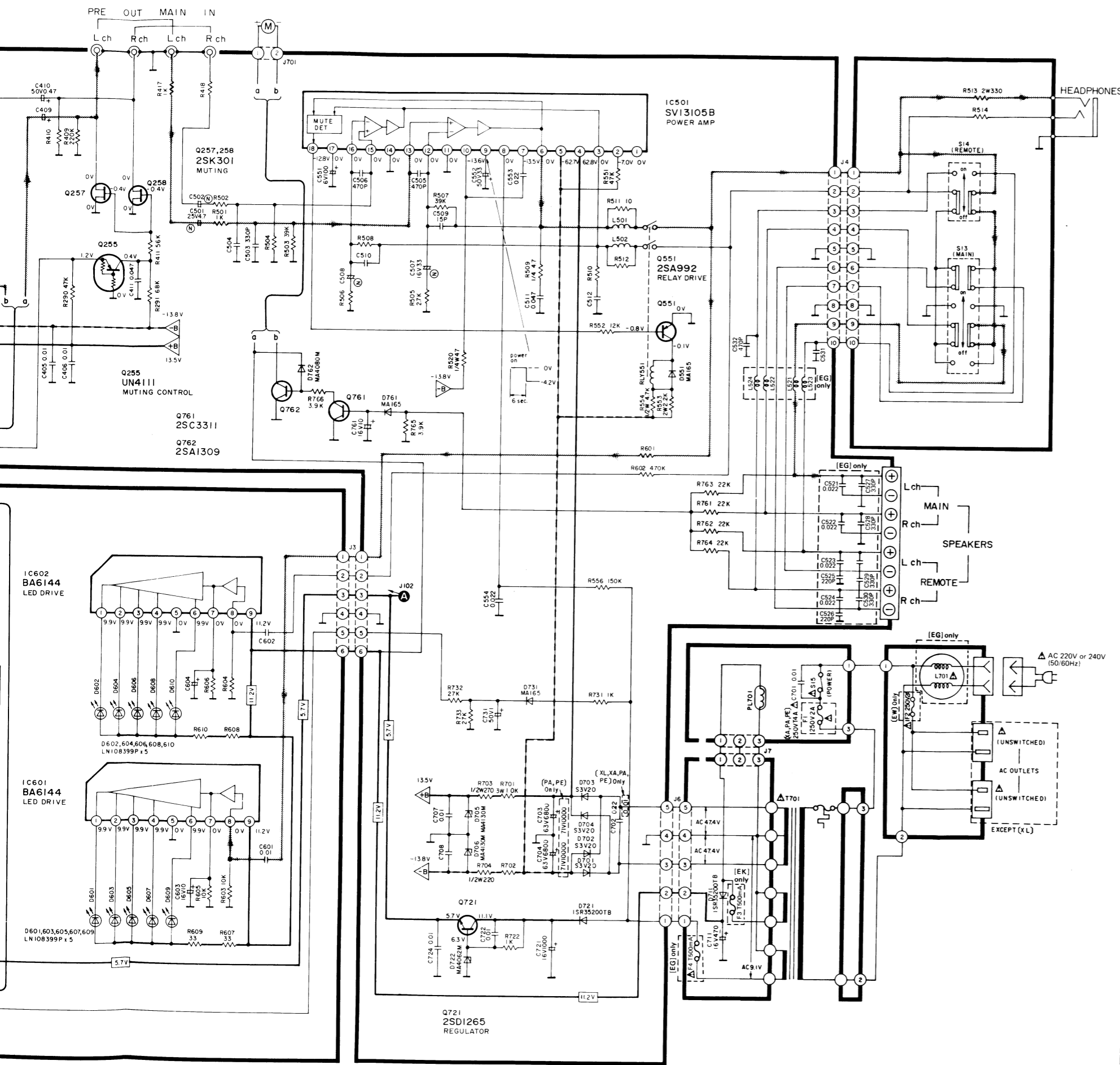

(This schematic diagram may be modified at any time with the development of new technology.)

Notes:

1. S1 : Volume, "Down" switch.
2. S2 : Volume, "Up" switch.
3. S3 : Balance, "Right" switch.
4. S4 : Balance, Left" switch.
5. S5 : Super bass switch.
6. S6 : Input selector, "Tape2/ext" switch.
7. S7 : Input selector, "Tape 1" switch.
8. S8 : Input selector, "CD/aux" switch.
9. S9 : Input selector, "Tuner" switch.
10. S10 : Input selector, "Phono" switch.
11. S13 : Main speakers switch in "on" position.
12. S14 : Remote speakers switch in "off" position.
13. S15 : Power switch in "on" position.
14. Indicated voltage values are the standard values for the unit measured by the DC electronic circuit tester (high-impedance) with the chassis taken as standard. Therefore, there may exist some errors in the voltage values, depending on the internal impedance of the DC circuit tester.
Measurement condition:
Input selector - phono (no signal)
Volume - Minimum
Loudness - off

15. Positive (+B) voltage lines
16. Negative (-B) voltage lines
17. Signal lines (L channel)

18. Impedance safety notice:
Components identified by Δ mark have special characteristics important for safety. When replacing any of these components, use only manufacturer's specified parts.

* Cauton!

- IC and LSI are sensitive to static electricity. Secondary trouble can be prevented by taking care during repair.
- * Cover the parts boxes made of plastics with aluminum foil.
- * Ground the soldering iron.
- * Put a conductive mat on the work table.
- * Do not touch the legs of IC or LSI with the fingers directly.

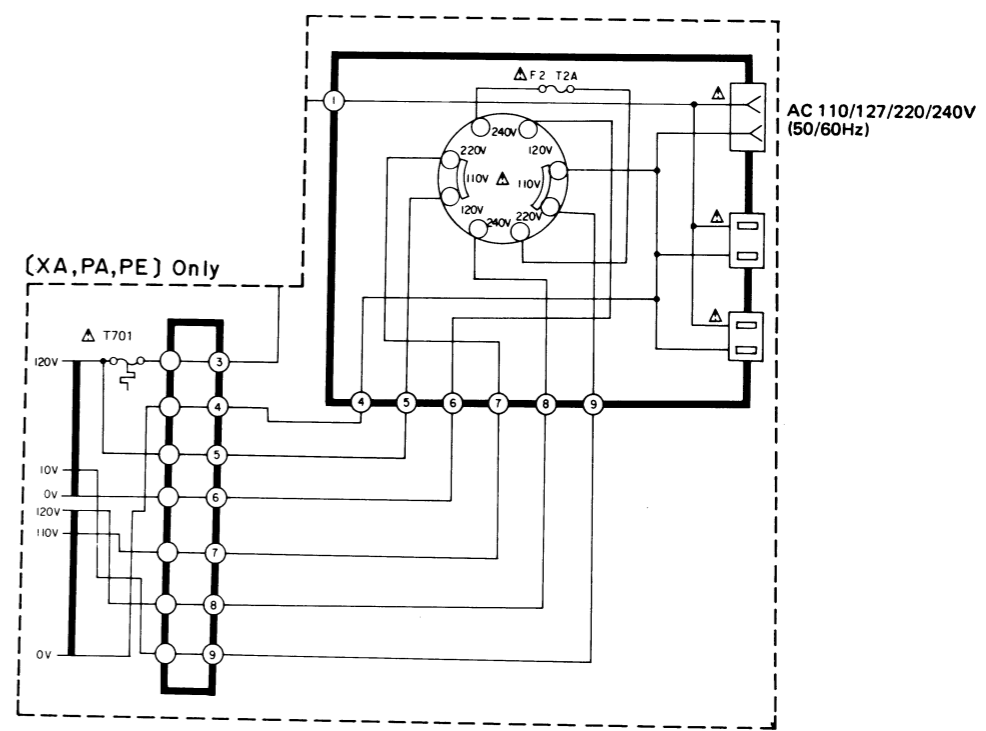

Service Manual

Stereo Integrated Amplifier

Amplifier

SU-V96

Color

(K)Black Type

Area

Color	Area
(K)	(PA)Far East PX.
(K)	(PE)European Military.

Please use this supplement manual together with the service manual for Model No. SU-V96, Order No. HAD8706167A4.

Notes:

- * The circuit of SU-V96 has been changed for the improvement of performance.
- * This supplement should be filed with the service manual for Model No. SU-V96, Order No. HAD8706167A4.

CHANGES

REPLACEMENT PARTS LIST

Ref. No.	Change of Part No.		Part Name & Description	Remarks
	OLD	→ NEW		
POWER-TURNFORMER				
T701 Δ	SLT5P279	SLT5P282	Power Source	Change
THERMISTORS				
TH201	-----	RRT104	Temperature Detector	Addition
TH202	-----	RRT104	Temperature Detector	Addition
RESISTORS				
R211	-----	ERDS2TJ272	Carbon, 1/4W, 2.7k Ω , \pm 5%	Addition
R212	-----	ERDS2TJ272	Carbon, 1/4W, 2.7k Ω , \pm 5%	Addition
R215	-----	ERDS2TJ102	Carbon, 1/4W, 1k Ω , \pm 5%	Addition
R216	-----	ERDS2TJ102	Carbon, 1/4W, 1k Ω , \pm 5%	Addition

Technics

Matsushita Electric Trading Co., Ltd.
P.O. Box 288, Central Osaka Japan

Panasonic Tokyo Office
Matsushita Electric Trading Co., Ltd.
6th Floor, World Trade Center Bldg.,
No. 4-1, Hamamatsu-cho 2-Chome, Minato-ku,
Tokyo 105, Japan

SU-V96

SCHEMATIC DIAGRAM

