

Service Manual

Stereo Integrated Amplifier

Amplifier

SU-X102

Color

(K) Black Type

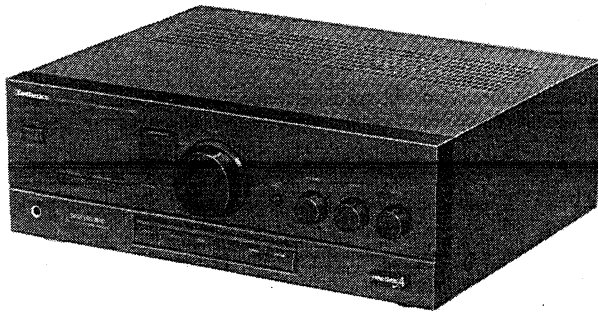

Areas

Country Code	Area	Color
(E)	Continental Europe	(K)
(EB)	Great Britain	
(EG)	F.R. Germany & Italy	
(GC)	Third Region	
(GN)	Oceania	

SPECIFICATIONS

(DIN 45 500)

■ AMPLIFIER SECTION

DIN power output	
1 kHz THD: 1 %	2 × 40 W (8 Ω)
Total harmonic distortion	
rated power at 1 kHz	1 % (8 Ω)
Harmonic distortion	
half power at 1 kHz	0.03 % (8 Ω)
Residual hum and noise	0.5 mV
Damping factor	30 (8 Ω)
Input sensitivity and impedance	
PHONO	3 mV/47 kΩ
TUNER, TAPE	150 mV/22 kΩ
CD, AUX1, 2	200 mV/22 kΩ
Maximum input voltage (1 kHz, RMS)	
PHONO	100 mV
S/N (rated power 8 Ω)	
PHONO	73 dB (IHF, A: 79 dB)
TUNER, CD, AUX1, 2, TAPE	82 dB (IHF, A: 83 dB)
Frequency response	
PHONO	RIAA standard curve
	±0.8 dB (30 Hz~15 kHz)
TUNER, CD, AUX1, 2, TAPE	15 Hz~50 kHz (-3 dB)
Tone controls	
BASS	50 Hz, +10 dB~-10 dB
TREBLE	20 kHz, +10 dB~-10 dB

Muting	-20 dB
Super bass	60 Hz, +8 dB
Output voltage	
TAPE REC OUT	150 mV
Channel balance, TUNER 250 Hz~6,300 Hz	±1.0 dB
Channel separation, TUNER 1 kHz	55 dB
Headphones output level and impedance	421 mV/330 Ω
Load impedance	
MAIN	8 Ω~16 Ω
SURROUND	8 Ω~16 Ω

■ GENERAL

Power consumption	230 W
Power supply	
For Continental Europe	AC 50 Hz/60 Hz, 220 V
For Great Britain and Oceania	AC 50 Hz/60 Hz, 230~240 V
For others	AC 50 Hz/60 Hz, 110 V/127 V/220 V/240 V
Dimensions (W × H × D)	360 × 129 × 305 mm
	(14-3/16" × 5-3/32" × 12")
Weight	5.3 kg (11.7 lb.)

Notes:

- Specifications are subject to change without notice.
Weight and dimensions are approximate.
- Total harmonic distortion is measured by the digital spectrum analyzer.

Technics

■ CONTENTS

	Page		Page
Before repair	2	Description of FL panel	13
Protection circuitry	2	Circuit board diagram	20~25
Accessories	2	Terminal guide of IC's, transistors and diodes	25
Location of controls	3	Wiring connection diagram	26
Standard operations	4	Block diagram	27, 28
Connections	4~6	Function of IC terminals	29
Disassembly instructions	7~10	Replacement parts list	30~33, 36
Schematic diagram	11~19	Cabinet parts location	34, 35
		Packaging	36

■ BEFORE REPAIR

- (1) Turn off the power supply. Using a 10Ω, 5 W resistor connect both ends of power supply capacitors (C711, C712, 3300 μF) in order to discharge the voltage.
- (2) Before turning the power supply on, after completion of repair, slowly apply the primary voltage by using a power supply voltage controller to make sure that the consumed current at 50 Hz/60 Hz in NO SIGNAL mode should be shown below with respect to supply voltage 110 V/127 V/220 V/240 V.

Power supply voltage	AC 110 V	AC 120 V	AC 220 V	AC 230 V	AC 240 V
Consumed current 50 Hz	181~424 mA	166~386 mA	96~224 mA	86~200 mA	87~204 mA
Consumed current 60 Hz	161~376 mA	148~346 mA	86~200 mA	75~175 mA	79~185 mA

■ PROTECTION CIRCUITRY

The protection circuitry may have operated if either of the following conditions is noticed:

- *No sound is heard when the power is switched ON.
- *Sound stops during a performance.

The function of this circuitry is to prevent circuitry damage if, for example, the positive and negative speaker connection wires are "shorted", or if speaker systems with an impedance less than the indicated rated impedance of this unit are used.

If this occurs, follow the procedure outlined below:

1. Switch OFF the power.
2. Determine the cause of the problem and correct it.
3. Switch ON the power once again.

Note:

When the protection circuitry functions, the unit will not operate unless the power is first switched OFF and then ON AGAIN.

■ ACCESSORIES

- AC power supply cord 1
Configuration of AC power supply cord differs according to area.
- Attachment AC plug 1
- SJA187 For (E) (EG) area only.
- SJA173 For (GN) area only.
- SJA188 For (EB) area only.
- RJA0004 For (GC) area only.
- SJP9215 For (GC) area only.

■ LOCATION OF CONTROLS

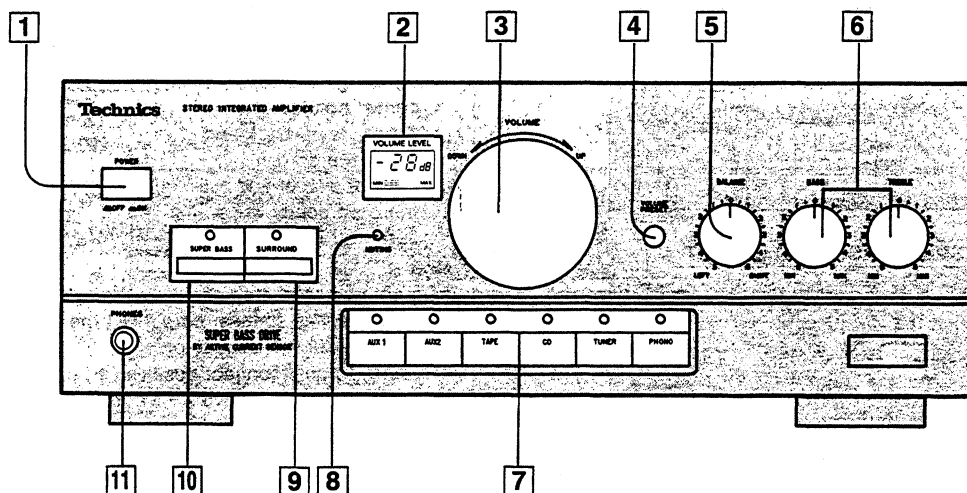

- | | |
|--|---|
| 1 Power switch (POWER) | 7 Input selectors/indicators |
| 2 Volume-level indicator (VOLUME LEVEL) | 8 Muting indicator (MUTING) |
| 3 Volume control (VOLUME) | 9 Surround-sound button/indicator (SURROUND) |
| 4 Volume preset button (VOLUME PRESET) | 10 Super bass button/indicator (SUPER BASS) |
| 5 Balance control (BALANCE) | 11 Headphones jack (PHONES) |
| 6 Tone controls (BASS/TREBLE) | |

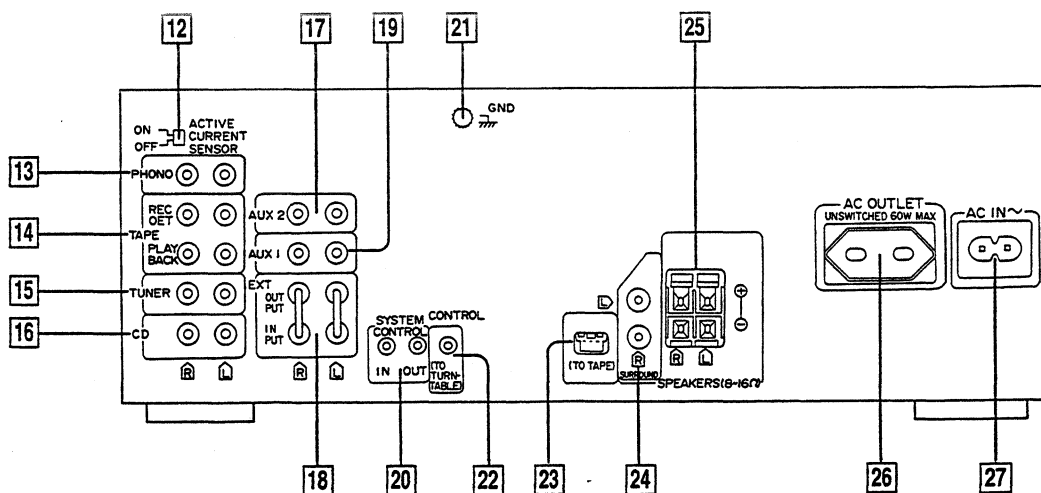

- | | |
|--|---|
| 12 Active current sensor switch | 21 GND terminal |
| 13 Phono input terminal | 22 Control terminal (to turntable) |
| 14 Tape rec out/playback terminal | 23 Control terminal (to cassette deck) |
| 15 Tuner input terminal | 24 Surround-sound speaker terminal |
| 16 CD input terminal | 25 Main speaker terminal |
| 17 AUX 2 input terminal | 26 AC outlet |
| 18 EXT output/input terminal | 27 AC inlet |
| 19 AUX 1 input terminal | |
| 20 System control IN/OUT terminal | |

STANDARD OPERATIONS

When listening to music

TREBLE

Adjust the high-frequency sound to the desired tone quality.

BASS

Adjust the low-frequency sound to the desired tone quality.

BALANCE

Adjust the balance of the left/right volume.

VOLUME

Adjust the volume level.

SUPER BASS

Press this button to boost the super-low frequency range. (The indicator will illuminate.)

SURROUND

Set to the "ON" position to activate the surround-sound effect. (The indicator will illuminate.)

Note:

The surround-sound effect is only effective for phono discs, compact discs, tapes that are recorded in stereo, and for FM and other broadcasts that are broadcast in stereo. It has no effect for monaural AM broadcasts, or for any other monaural source. When listening to a sound source recorded by the surround-sound method, set this switch to the "OFF" position.

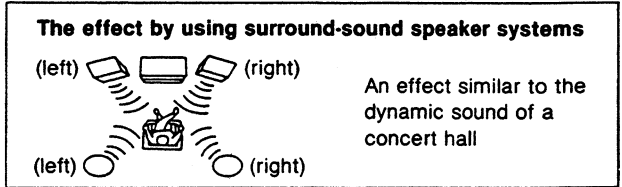

During recording

Operation of controls or switches other than the surround-sound switch has no influence upon recording.

CONNECTIONS

To connect the amplifier with the cassette deck

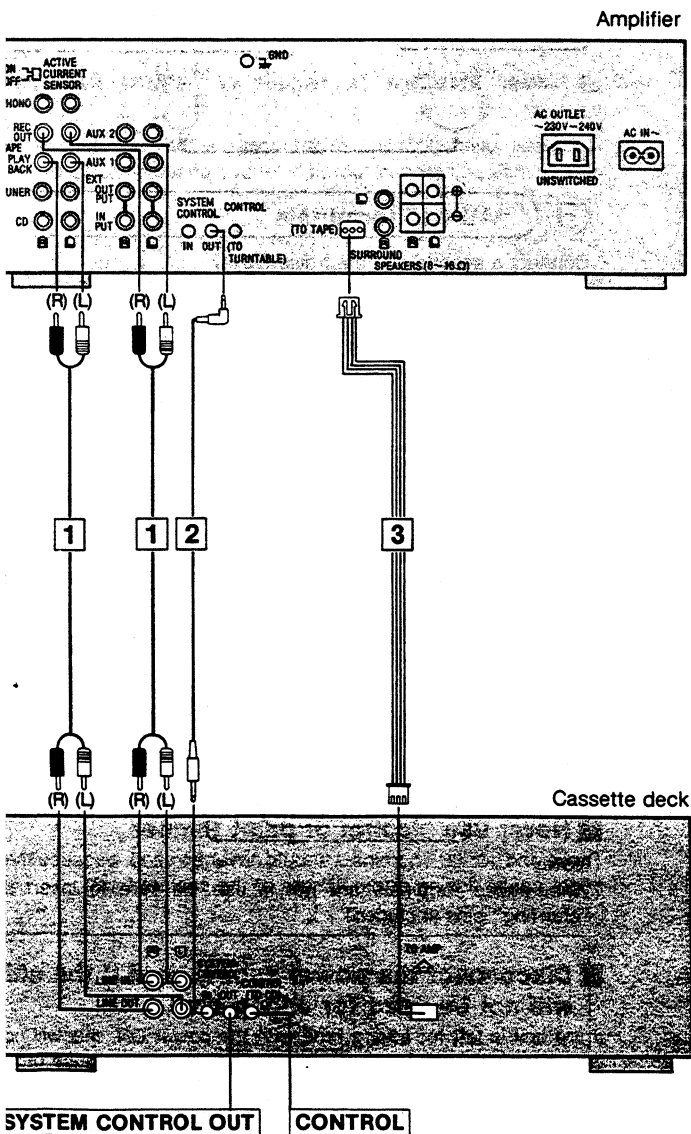

Make connections in the numbered sequence by using the included cables.

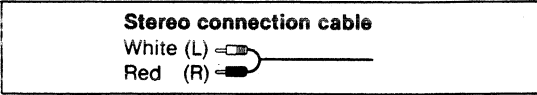

See the operating instructions of the tuner (ST-X302L) for details.

- 1 Connect the stereo connection cables.
- 2 Connect the L-type cable.
- 3 Connect the flat cable.

SYSTEM CONTROL OUT

This terminal is used to connect a Technics compact disc player or a Technics stereo graphic equalizer with the "SYSTEM CONTROL IN" terminal.

CONTROL

This terminal is used to connect a Technics multi compact disc player with the "CONTROL" terminal.

To connect the amplifier with other units

Make connections to each component in the system by using stereo connection cables (not included).

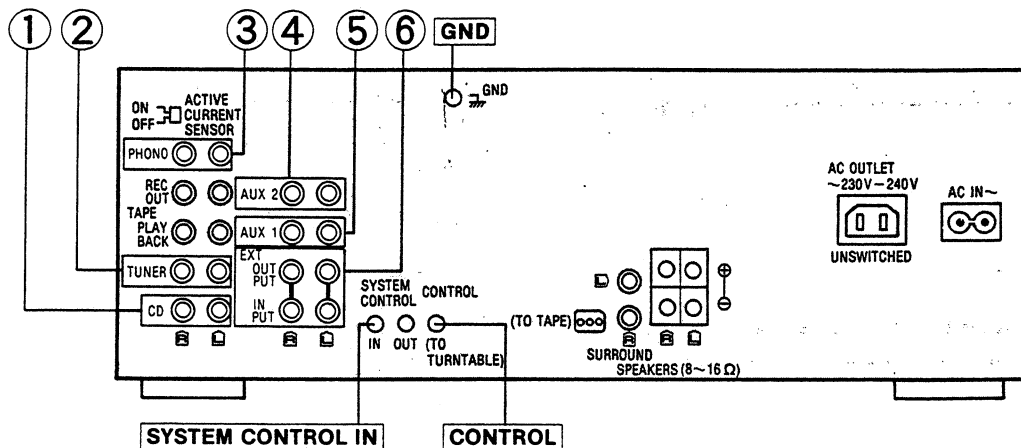

1 "CD" terminals

Connect a compact disc player.

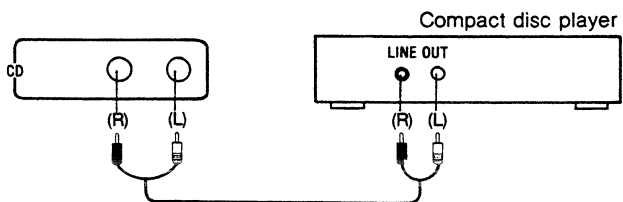

4 "AUX 2" terminals

Connect a video disc player etc. (Only the audio is connectable)

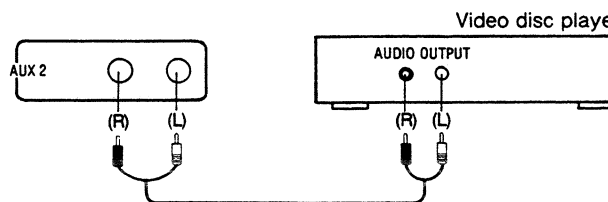

2 "TUNER" terminals

Connect a tuner.

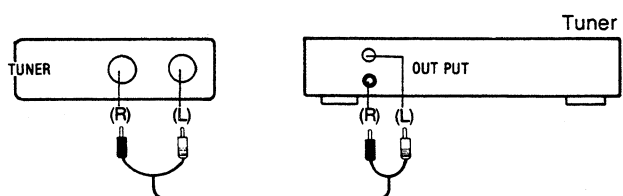

5 "AUX 1" terminals

Connect a second compact disc player.

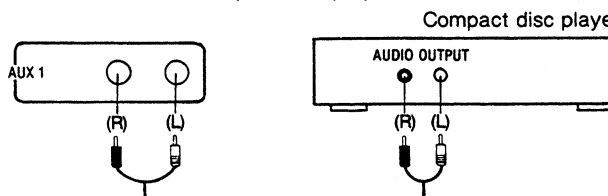

SYSTEM CONTROL IN terminal

This terminal is used to connect a Technics tuner with the "SYSTEM CONTROL OUT" terminal.

3 "PHONO" terminals

Connect a turntable.

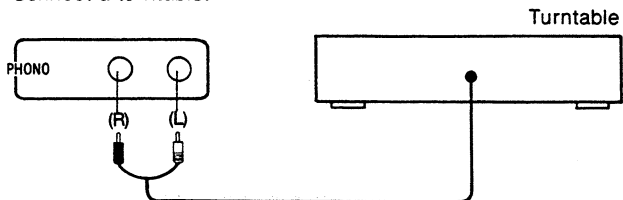

"GND" terminal of the amplifier

This terminal is for use with a turntable which has a ground wire.

"CONTROL (TO TURNTABLE)" terminal

This terminal is used to connect a Technics turntable with the "REMOTE/SYNCHRO REC" terminal.

6 "EXT" terminals

Connect a graphic equalizer.

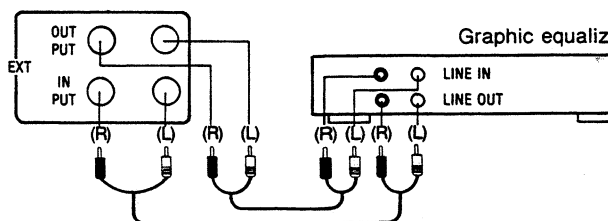

Note:

When these terminals are not in use, be sure to insert the "shorting" pins (included).

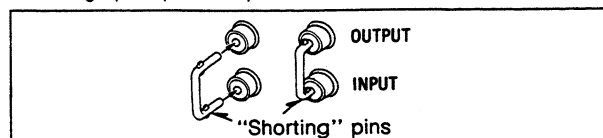

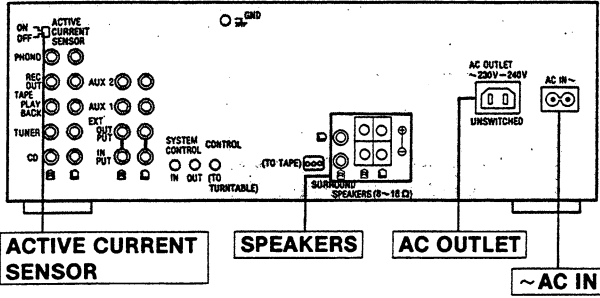

Connection of speaker systems

Two pairs of speaker systems (main, surround-sound) can be connected to the amplifier. Speaker systems that can be connected to any of the speaker connection terminals of the amplifier are speaker systems with an impedance of 8 to 16 ohms. Make connections to each speaker system by using speaker cords (not included).

Main speaker systems (not included)

Connect to the "SPEAKER" terminals.

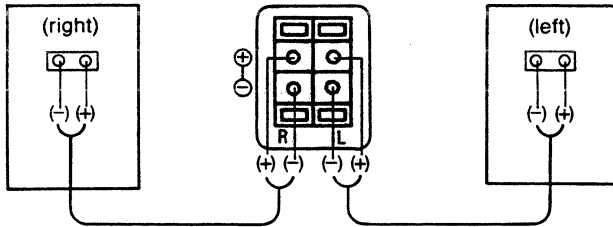

Surround-sound speaker systems (not included)

Connect to the "SURROUND" terminals. Be sure to connect both speaker systems. If only one side is connected, no sound will be heard.

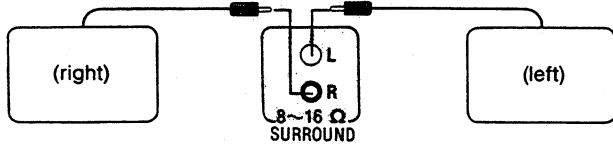

How to use the active current sensor

The selector is used to enjoy powerful super-bass sound.
ON: Switch ON when connecting the Technics system speakers (SB-CS50).
OFF: Switch OFF when connecting speakers other than Technics system speakers.
Note: When connecting speakers other than system speakers, sound from the speakers may not be heard if the selector is pressed ON, because the protecting circuit on the amplifier becomes active.

To connect cords to terminals

- Strip off the outer covering, and twist the center conductor. 15 mm (19/32") Twist.
- Tilt the lever back and insert the cord.
- Close the lever and pull the cord gently to be sure that it is secure.

Notes:

- Do not use solid core speaker wire.
- To connect the speaker cord, twist the strands on the end. Do not solder the conductor.
- Be sure to only connect positive (+) cords to positive (+) terminals, and negative (-) cords to negative (-) terminals.

Note:

To prevent damage to circuitry, never short-circuit the plus (+) and minus (-) speaker wires.

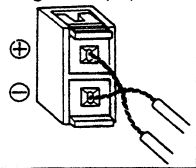

AC outlet ("AC OUTLET")

Do not connect video equipment (such as a TV, etc.) to the AC outlet of this unit. (This outlet is intended for audio equipment.) Do not exceed the indicated power ratings when connecting to this outlet.

"UNSWITCHED" outlet

Power is always available, regardless of power switch. Audio equipment rated up to 60 W can be connected here.

Note:

The configuration of the AC outlet differs according to area.

AC power supply cord

Connect the AC power supply cord (included) after all other cables and cords are connected.

Notes:

- Configuration of the AC outlet and AC power supply cord differs according to area.
- If this unit is not to be connected with the tuner, the cord is to be connected to the household AC outlet.

Tuner (not included)

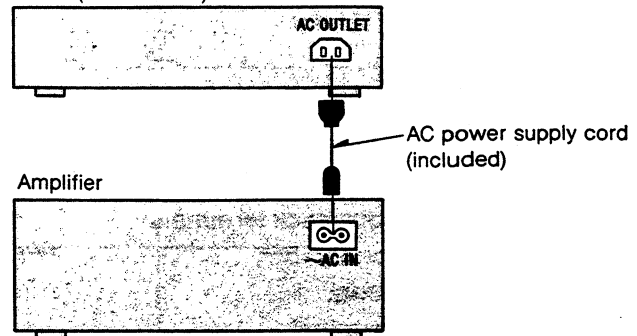

For United Kingdom

Cut off and dispose of the plug and replace with a suitable plug. (Refer to "For United Kingdom" on page 2.)

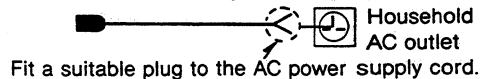

DISASSEMBLY INSTRUCTIONS

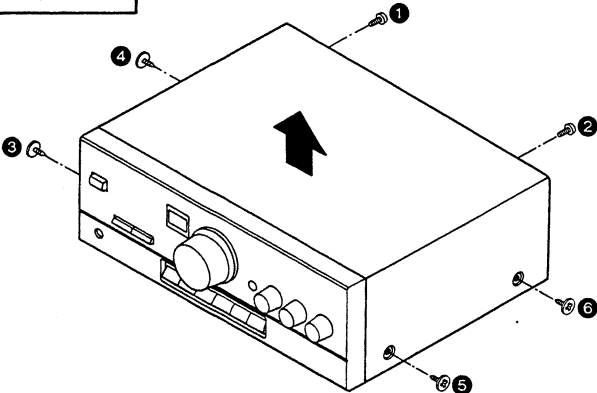
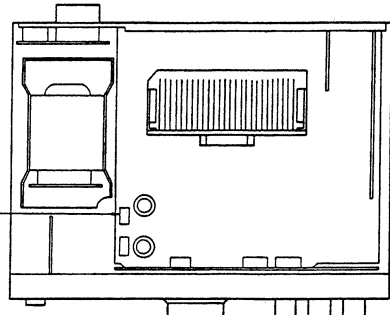
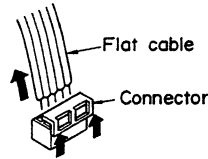
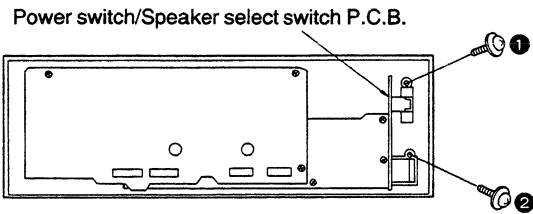
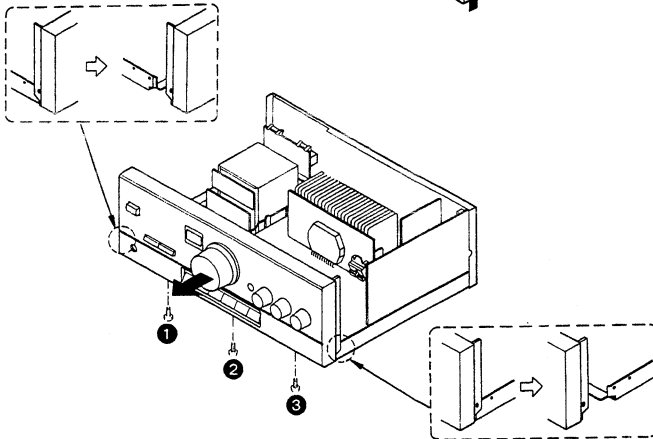
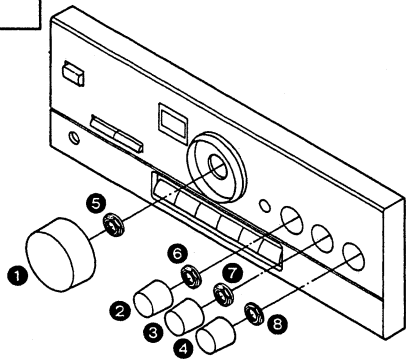
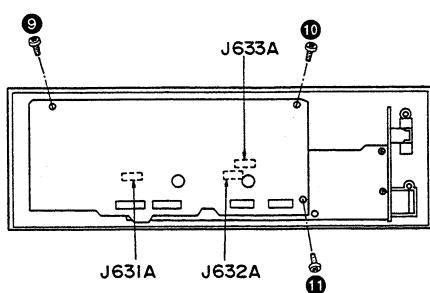
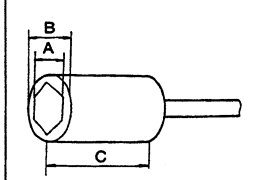
<p>Ref. No. 1</p>	<p>Removal of the Cabinet</p>	<p>Ref. No. 2</p>	<p>Removal of the Front Panel Unit</p>
<p>Procedure 1</p>	 <ol style="list-style-type: none"> 1. Remove the 6 screws (1~6). 2. Remove the cabinet in the direction of the arrow. 	<p>Procedure 1→2</p>	 <p>J501</p> <ol style="list-style-type: none"> 1. Remove the connector (J501). <p>—Removal of the Connector—</p>  <p>Flat cable Connector</p>
<p>Ref. No. 3</p>	<p>Removal of the Power Switch/Speaker Select Switch P.C.B.</p>		
<p>Procedure 1→2→3</p>	 <p>Power switch/Speaker select switch P.C.B.</p> <ul style="list-style-type: none"> • Remove the 2 screws (1, 2). 		 <ol style="list-style-type: none"> 2. Remove the 3 screws (1~3). 3. Remove the front panel unit in the direction of the arrow.
<p>Ref. No. 4</p>	<p>Removal of FL Drive P.C.B.</p>		
<p>Procedure 1→2→4</p>	 <ol style="list-style-type: none"> 1. Remove the 4 knobs (1~4). 2. Remove the 4 nuts (5~8). 	 <p>J631A J632A J633A</p> <ol style="list-style-type: none"> 3. Remove the 3 screws (9~11). 4. Remove the 3 connectors (J631A, J632A, J633A). 	 <p>A=11 mm B=16 mm C=longer than 22 mm</p> <ul style="list-style-type: none"> • Use a wrench of the dimensions shown in the illustration above to remove nuts.

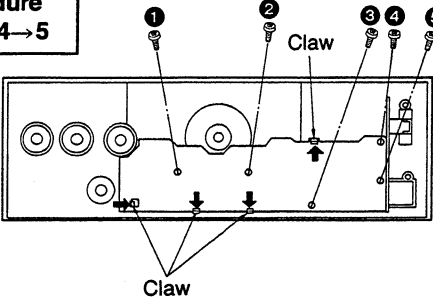
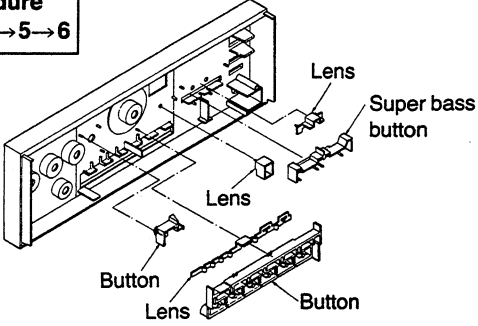
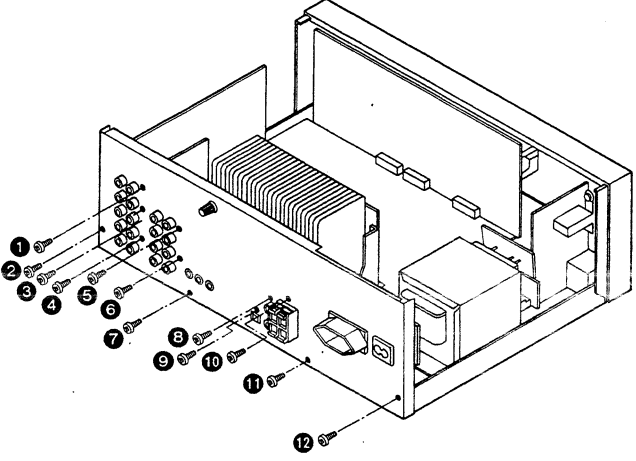
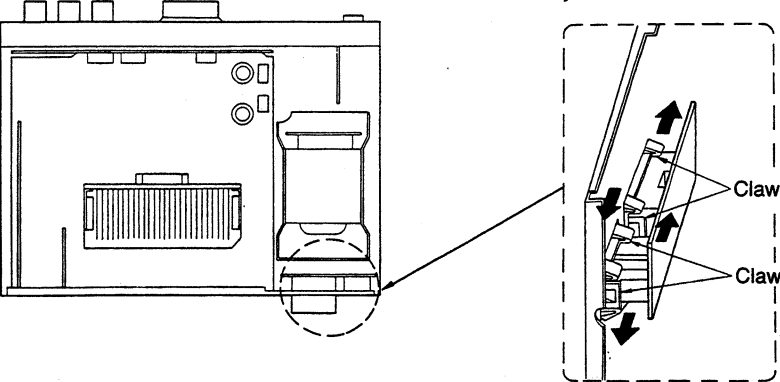
<p>Ref. No. 5</p>	<p>Removal of the Operation P.C.B.</p>	<p>Ref. No. 6</p>	<p>Removal of the Operation Buttons</p>
<p>Procedure 1→2→4→5</p>	 <p>1. Remove the 5 screws (①~⑤). 2. Release the 4 claws in the direction of arrow.</p>	<p>Procedure 1→2→4→5→6</p>	 <p>●Pull out the operation buttons and lens.</p>
<p>Ref. No. 7</p>	<p>Removal of the Rear Panel</p>		
<p>Procedure 1→7</p>	 <p>●Remove the 12 screws (①~⑫).</p>		
<p>Ref. No. 8</p>	<p>Removal of the AC OUTLET/AC IN P.C.B.</p>		
<p>Procedure 1→8</p>	 <p>●Release the 4 claws.</p>		

Ref. No. 9	Removal of the P.C.B.s
Procedure 1→7→9	

●Remove the P.C.B. in the direction of the arrow.

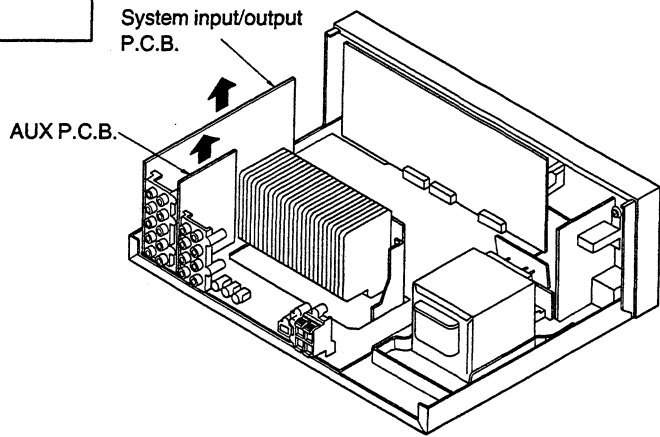

Ref. No. 10	Check of the main P.C.B.
Procedure 1→10	

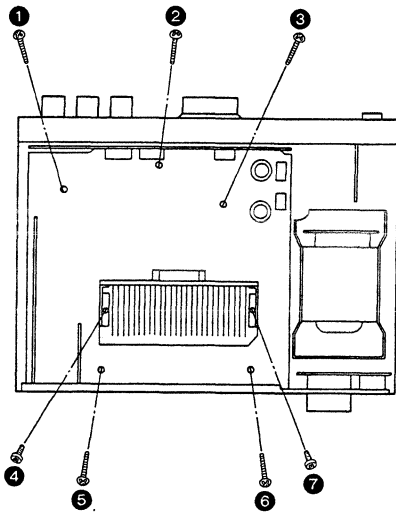

1. Remove the 7 screws (1~7).

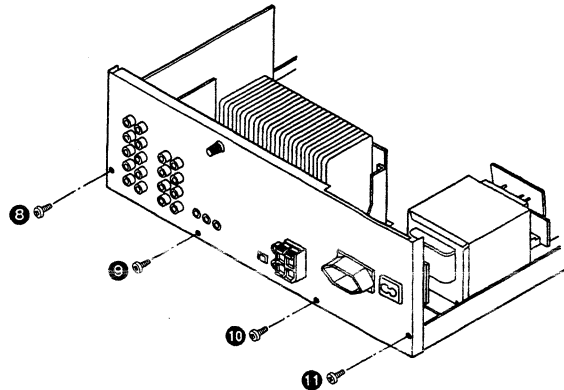

2. Remove the 4 screws (8~11).

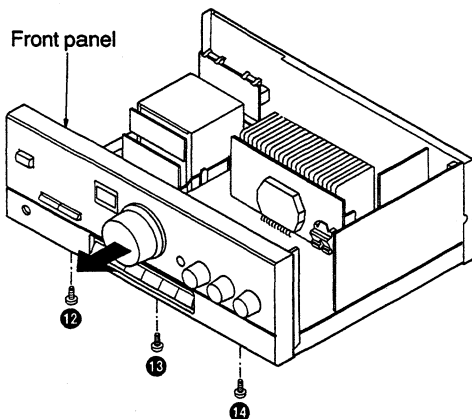

3. Remove the 3 screws (12~14).
4. Remove the front panel unit in the direction of the arrow.
*Connect 2 flat cables (J501A, J502).

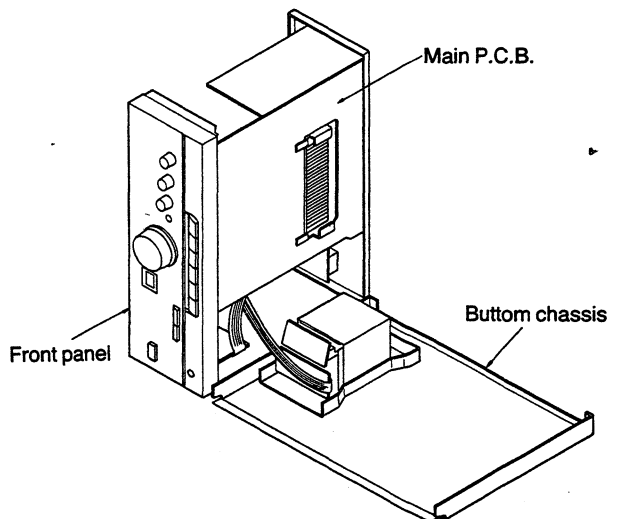

5. Remove the bottom chassis.
6. Reinstall the front panel unit to the main P.C.B.

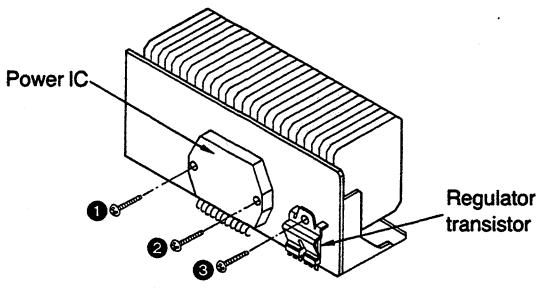
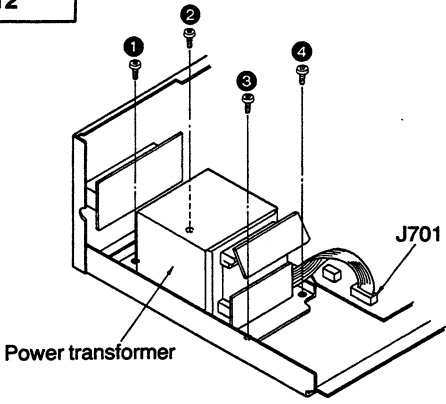
Ref. No. 11	Removal of the Power IC and Regulator Transistor	Ref. No. 12	Removal of the Power Transformer
Procedure 1→10→11	<ol style="list-style-type: none"> 1. Unsolder the power IC or regulator transistor. 2. Remove the 3 screws (①~③). 	Procedure 1→12	
	 <p>Note: When mounting the power IC, or regulator transistor apply silicon terminal compound (SZZ0L15) to the rear of the power IC or regulator transistor.</p>		 <ol style="list-style-type: none"> 1. Remove the 1 flat cable (J701). 2. Remove the 4 screws (①~④).

“ATTENTION SERVICER”

Some chassis components may have sharp edges. Be careful when disassembling and servicing.

●Replacement of the Foot.

1. Remove the 4 heat melted posts on the chassis with a pair of nippers or similar tool.
2. To replace the foot (RKA0011-2) on the chassis, melt the 4 posts with a soldering iron.

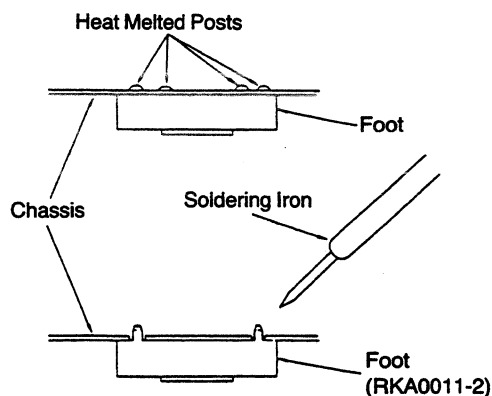

SCHEMATIC DIAGRAM

1 2 3 4 5 6 7 8 9 10

A FL DRIVE CIRCUIT

B OPERATION SWITCH CIRCUIT

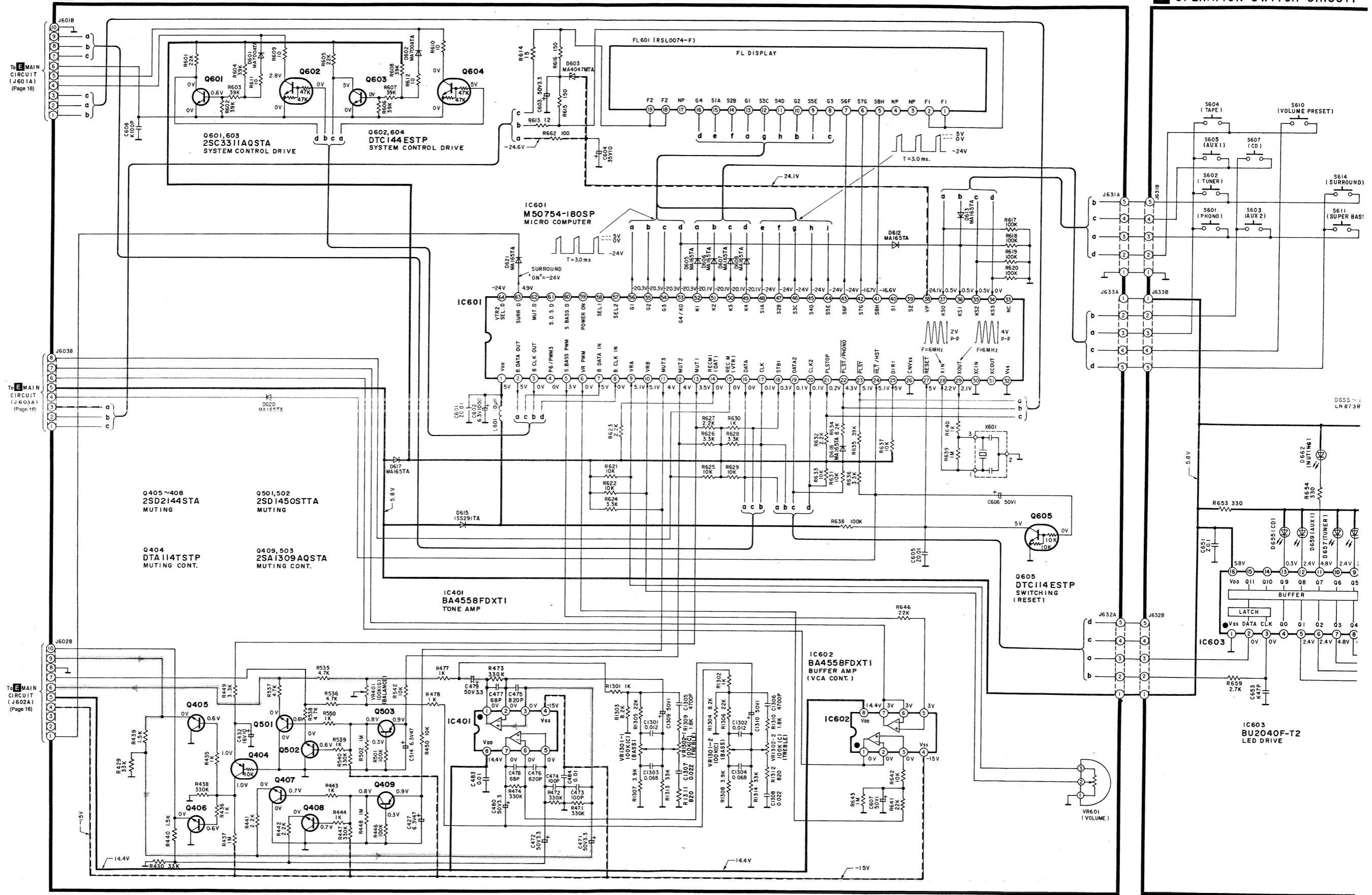

SCHEMATIC DIAGRAM

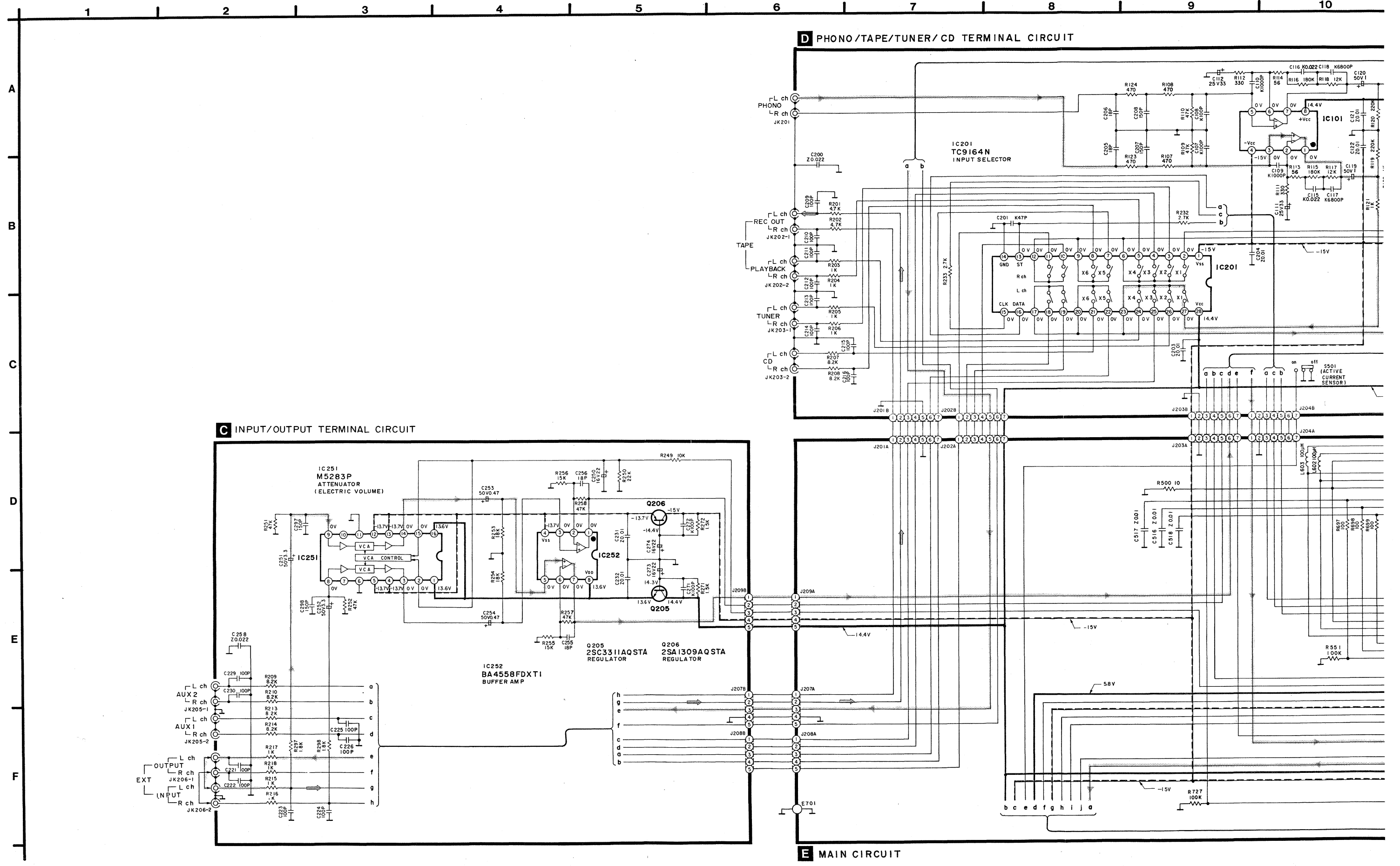

D PHONO/TAPE/TUNER/CD TERMINAL CIRCUIT

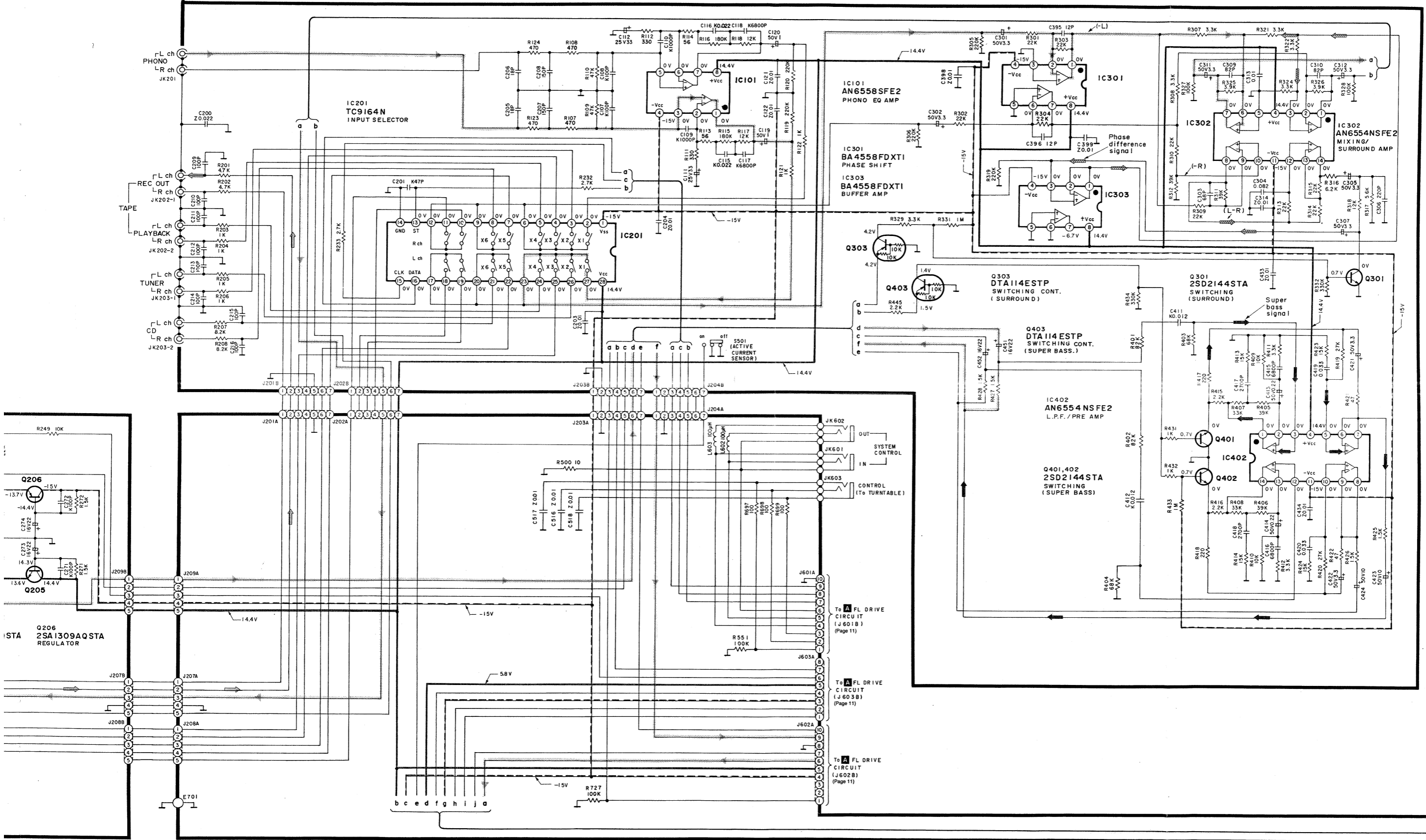

E MAIN CIRCUIT

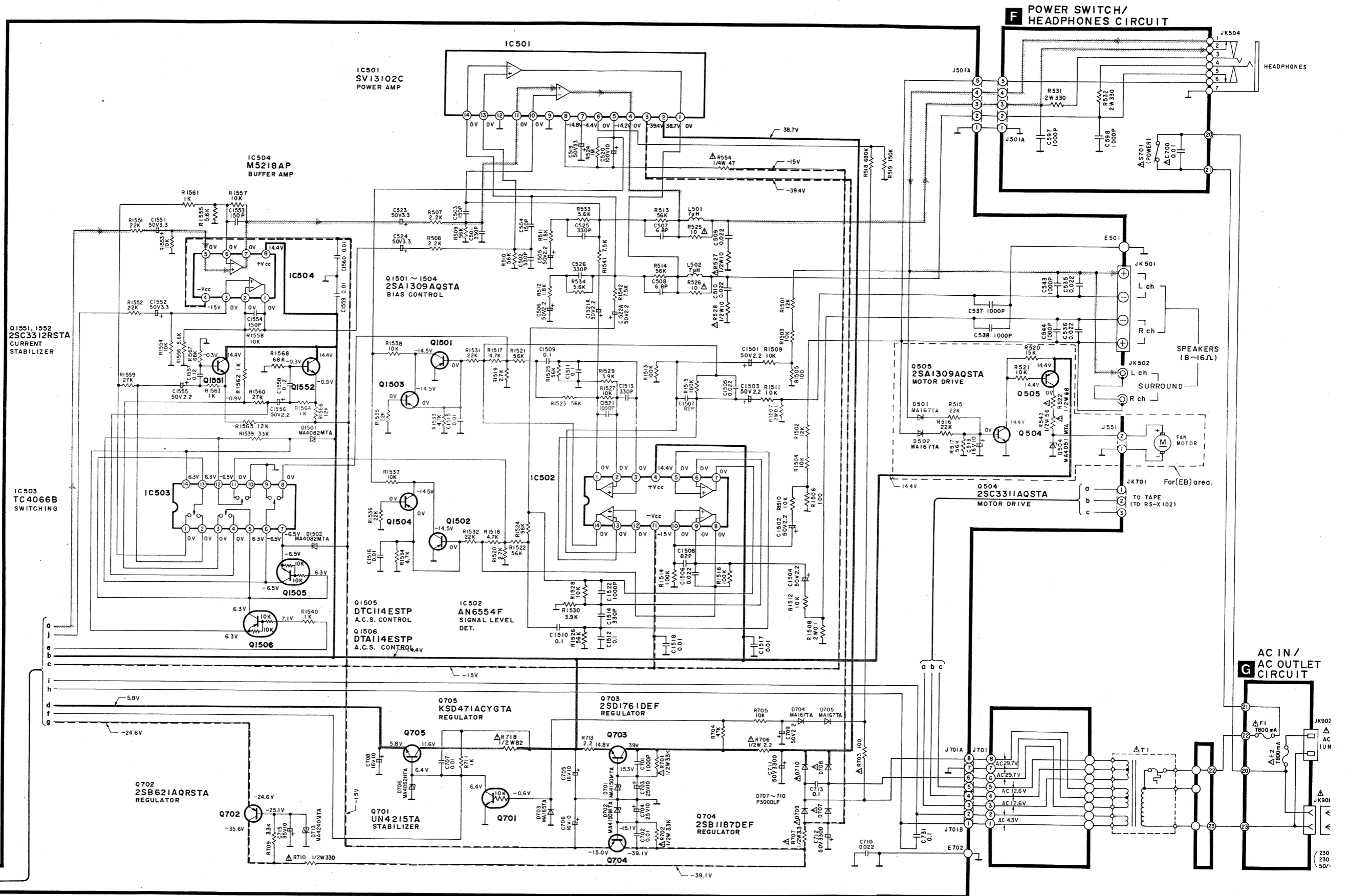

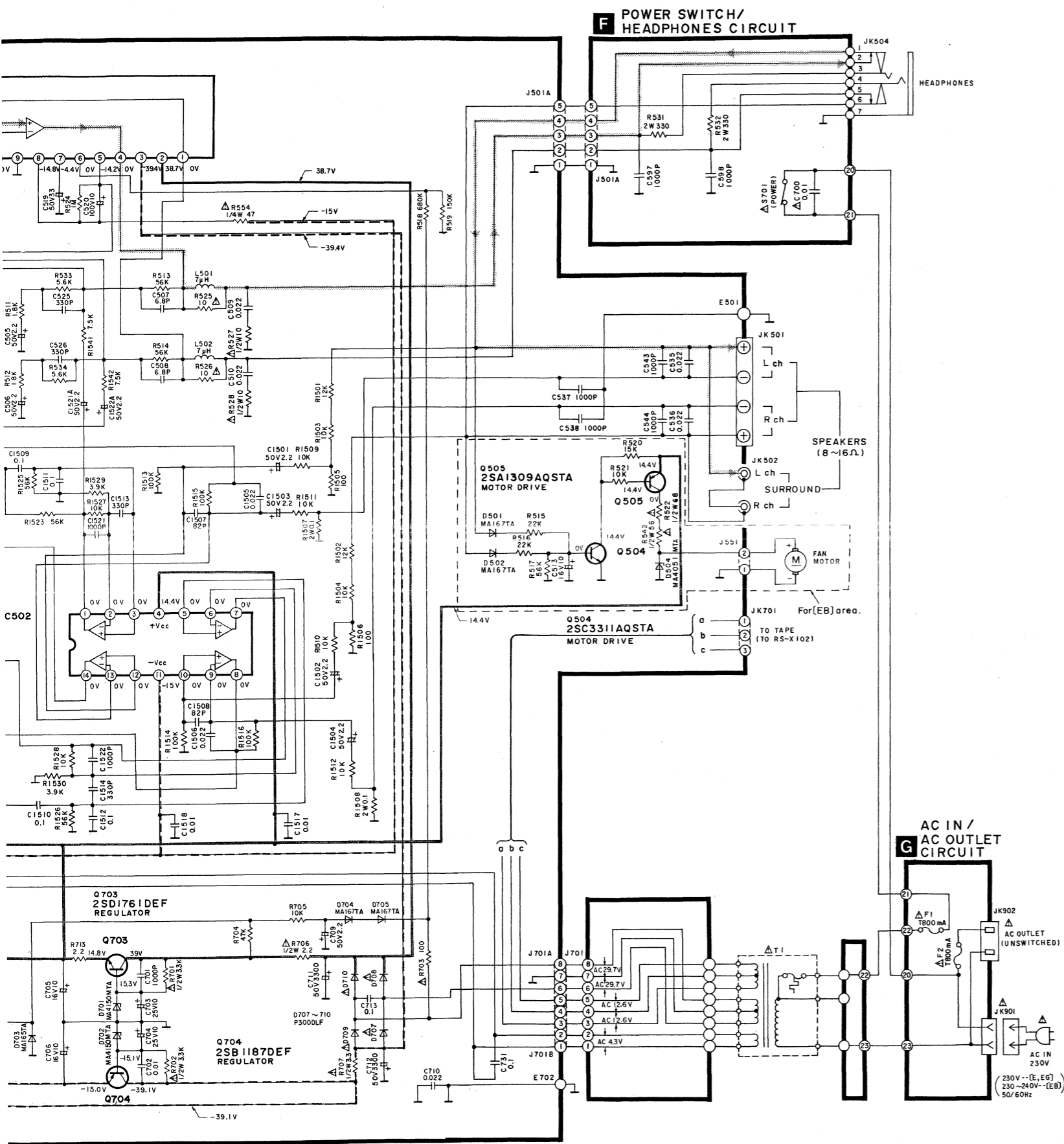

Notes: (This schematic diagram may be modified at any time with the development of new technology.)

- S501 : Active sensor switch in "OFF" position.
- S701 : POWER switch in "ON" position.
- S702 : Voltage select switch in "220 V" position. [for (GC) only]

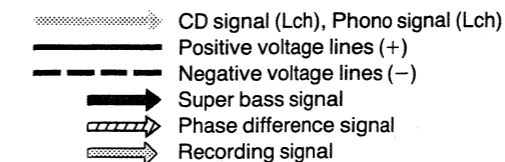

- Indicated voltage values are the standard values for the unit measured by the DC electronic circuit tester (high-impedance) with the chassis taken as standard. Therefore, there may exist some errors in the voltage values, depending on the internal impedance of the DC circuit tester.
- Important safety notice: Components identified by Δ mark have special characteristics important for safety. When replacing any of these components, use only manufacturer's specified parts.

- Caution!
IC and LSI are sensitive to static electricity. Secondary trouble can be prevented by taking care during repair.
- Cover the parts boxes made of plastics with aluminum foil.
- Ground the soldering iron.
- Put a conductive mat on the work table.
- Do not touch the legs of IC or LSI with the fingers directly.

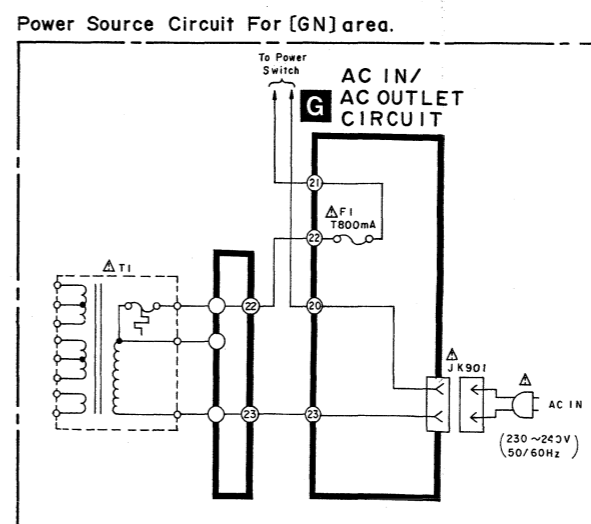
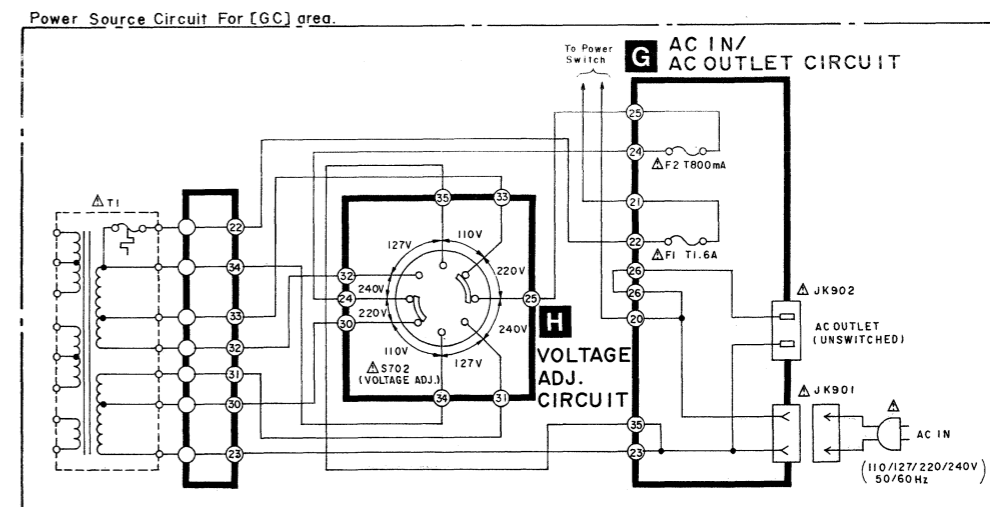

CIRCUIT BOARD DIAGRAM

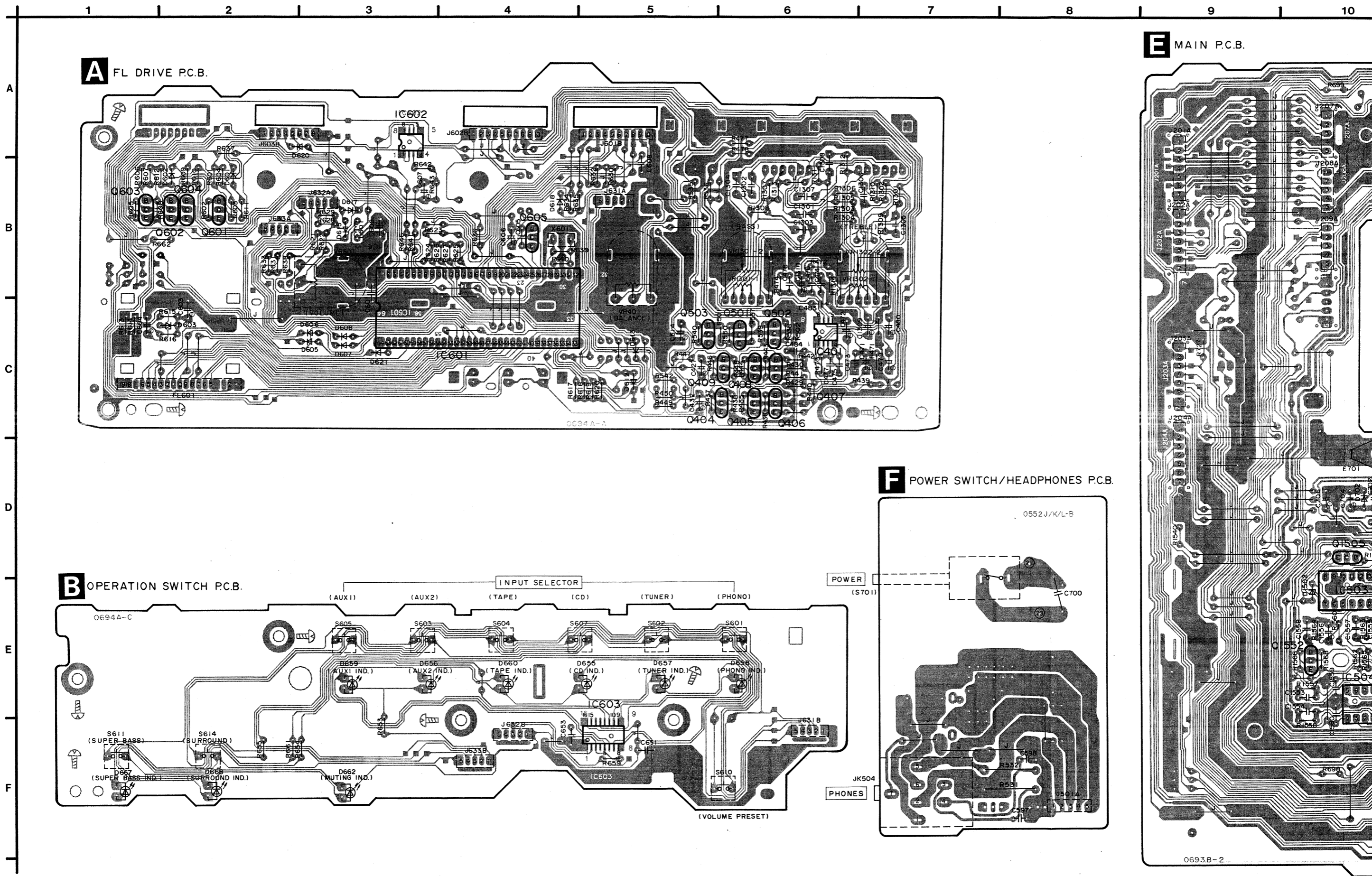

5 | 6 | 7 | 8 | 9 | 10 | 11 | 12 | 13 | 14

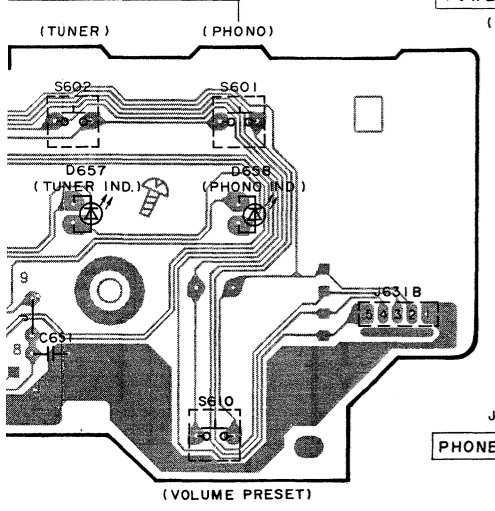
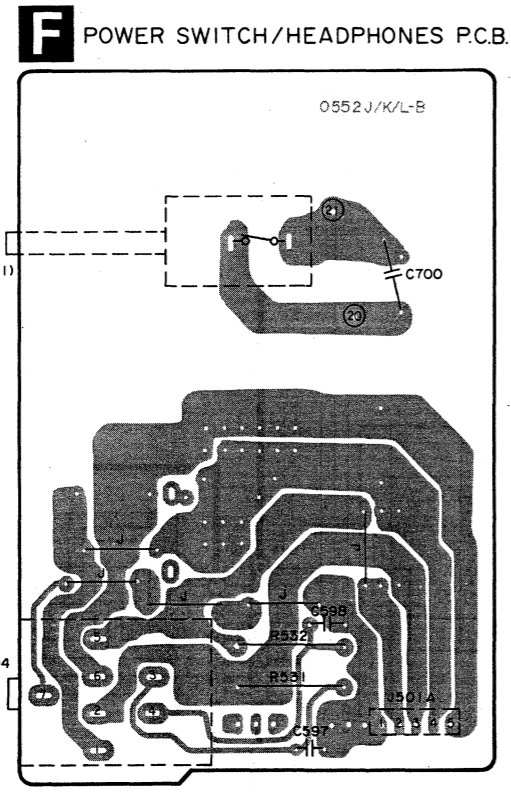
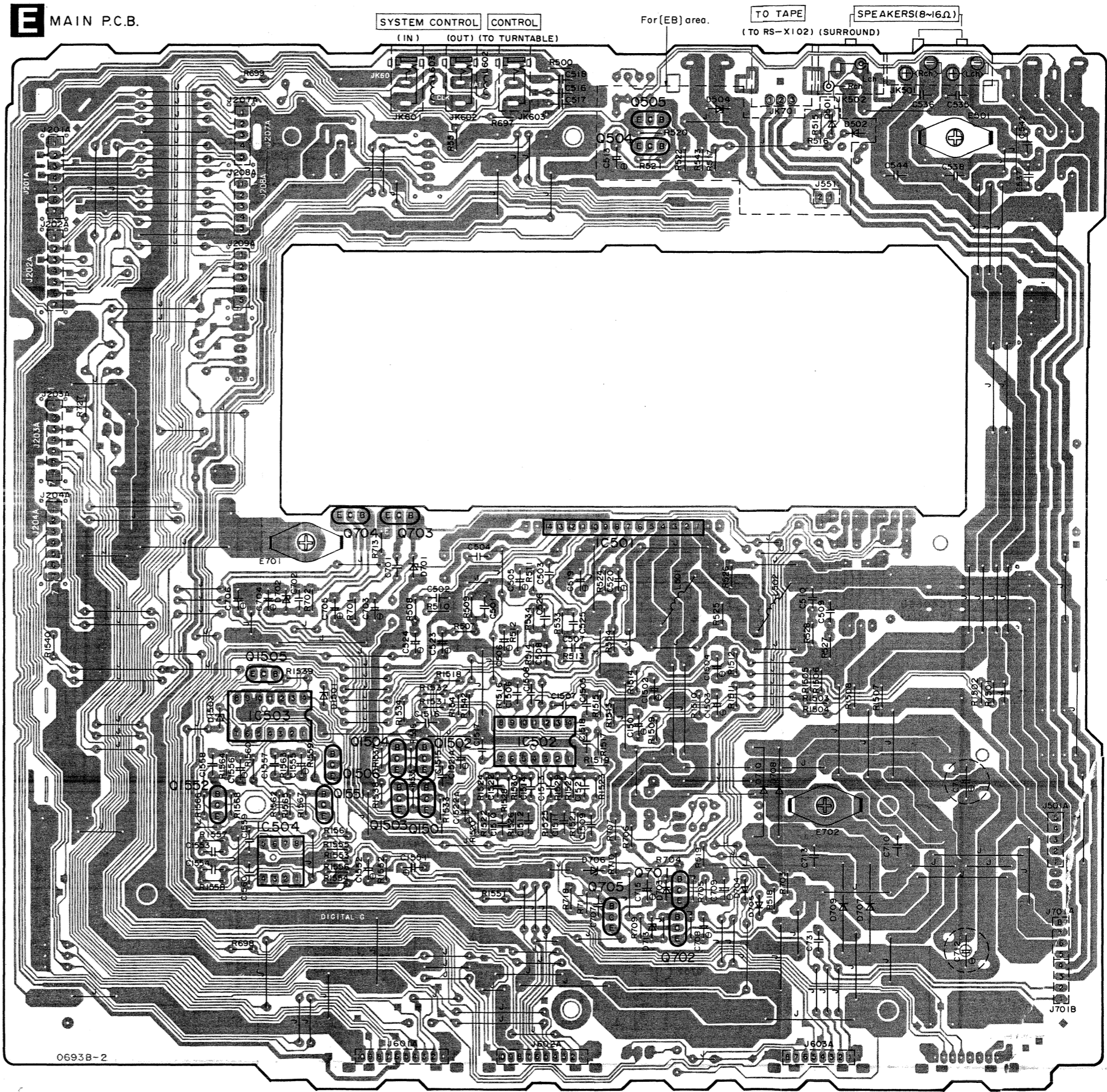
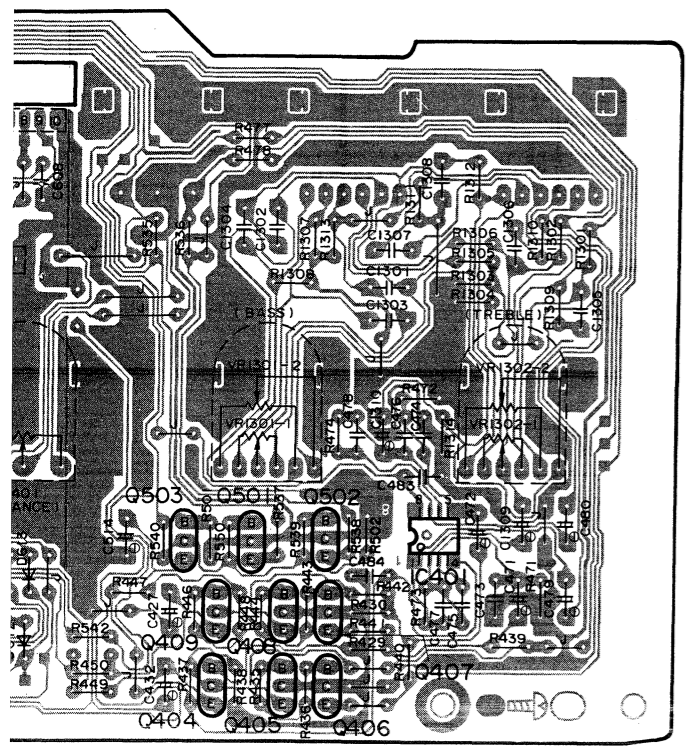

CIRCUIT BOARD DIAGRAM

1 2 3 4 5 6 7 8 9 10

A
B
C
D
E
F

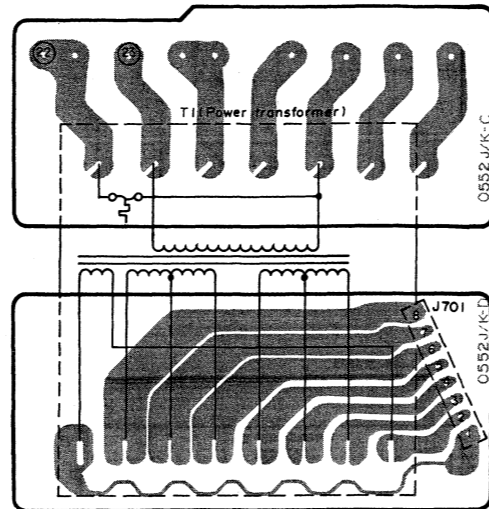
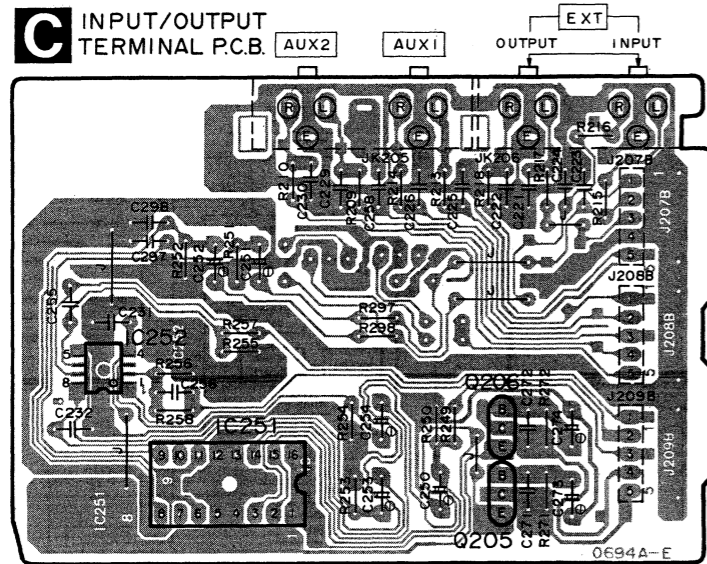

G AC IN/AC OUTLET P.C.B. For(E,EB,EG)AREAS.

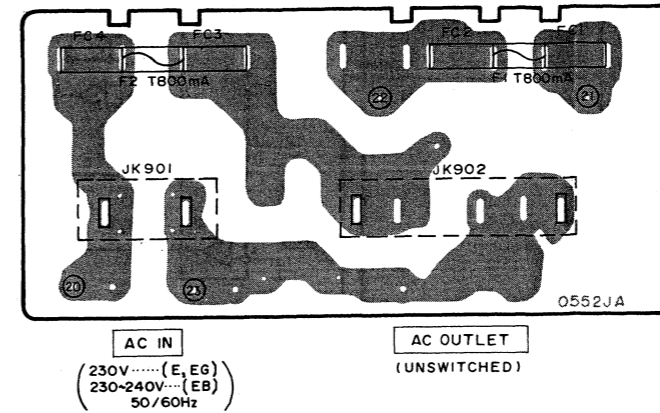

G AC IN/AC OUTLET P.C.B. For(I

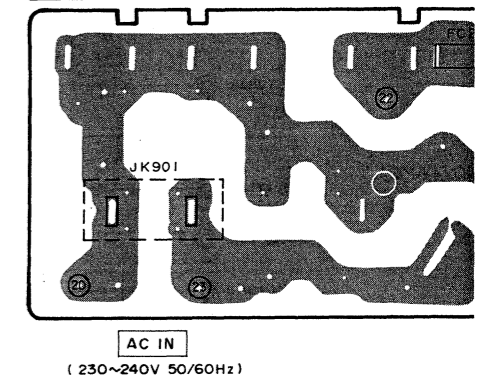

D PHONO/TAPE/TUNER/CD TERMINAL P.C.B.

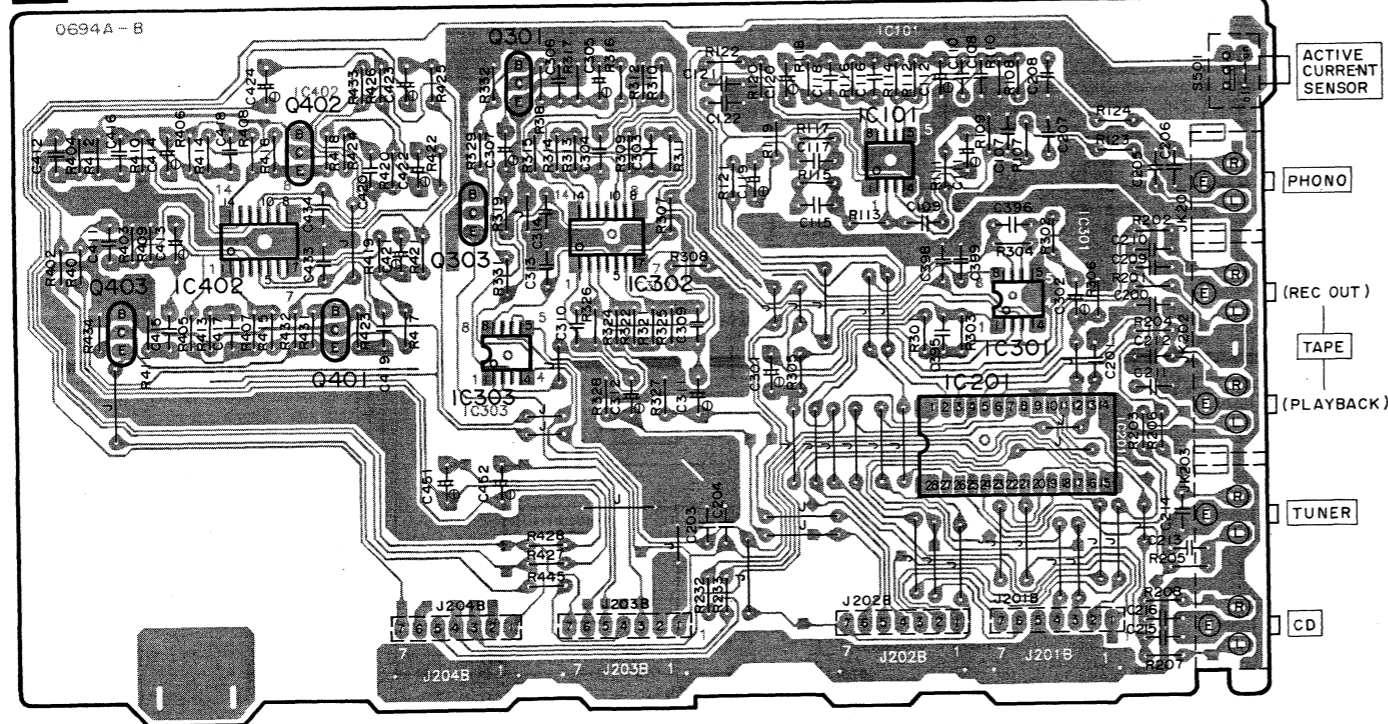

Power Source P.C.B. For(GC) area.

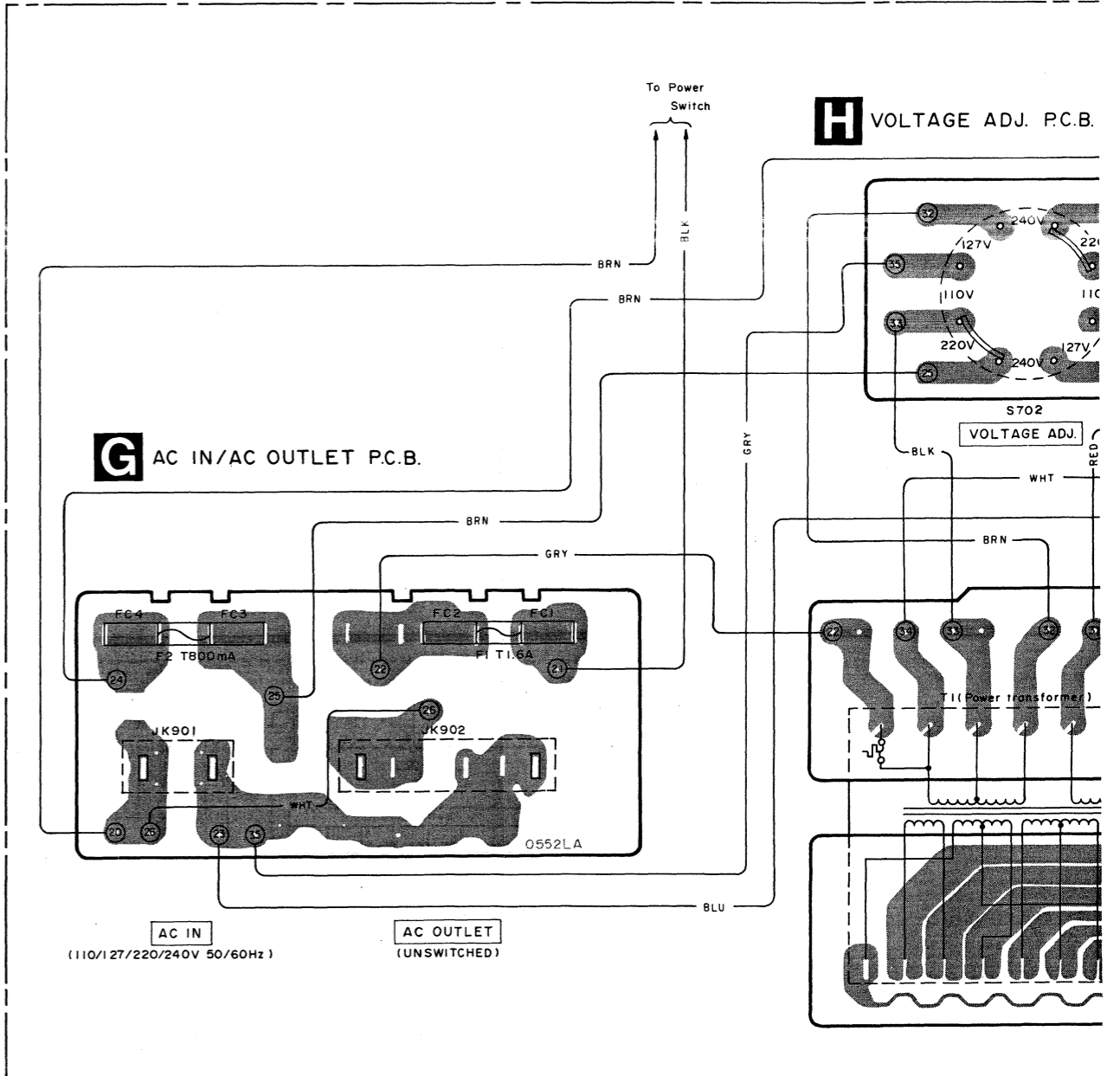

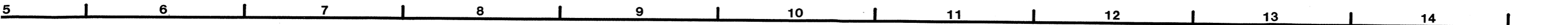

G AC IN/AC OUTLET P.C.B. For[E,EB,EG]AREAS.

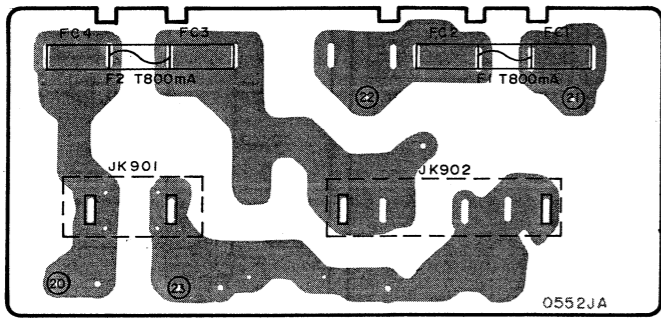

AC IN
(230V.....(E, EG)
(230~240V.....(EB)
50/60Hz)

AC OUTLET
(UNSWITCHED)

G AC IN/AC OUTLET P.C.B. For[GN] AREA.

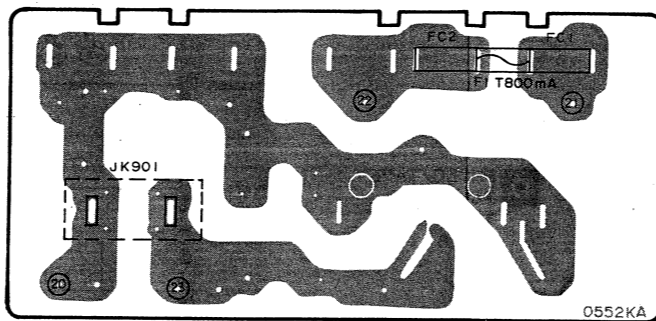

AC IN
(230~240V 50/60Hz)

AC OUTLET
(UNSWITCHED)

Power Source P.C.B. For[GC] area.

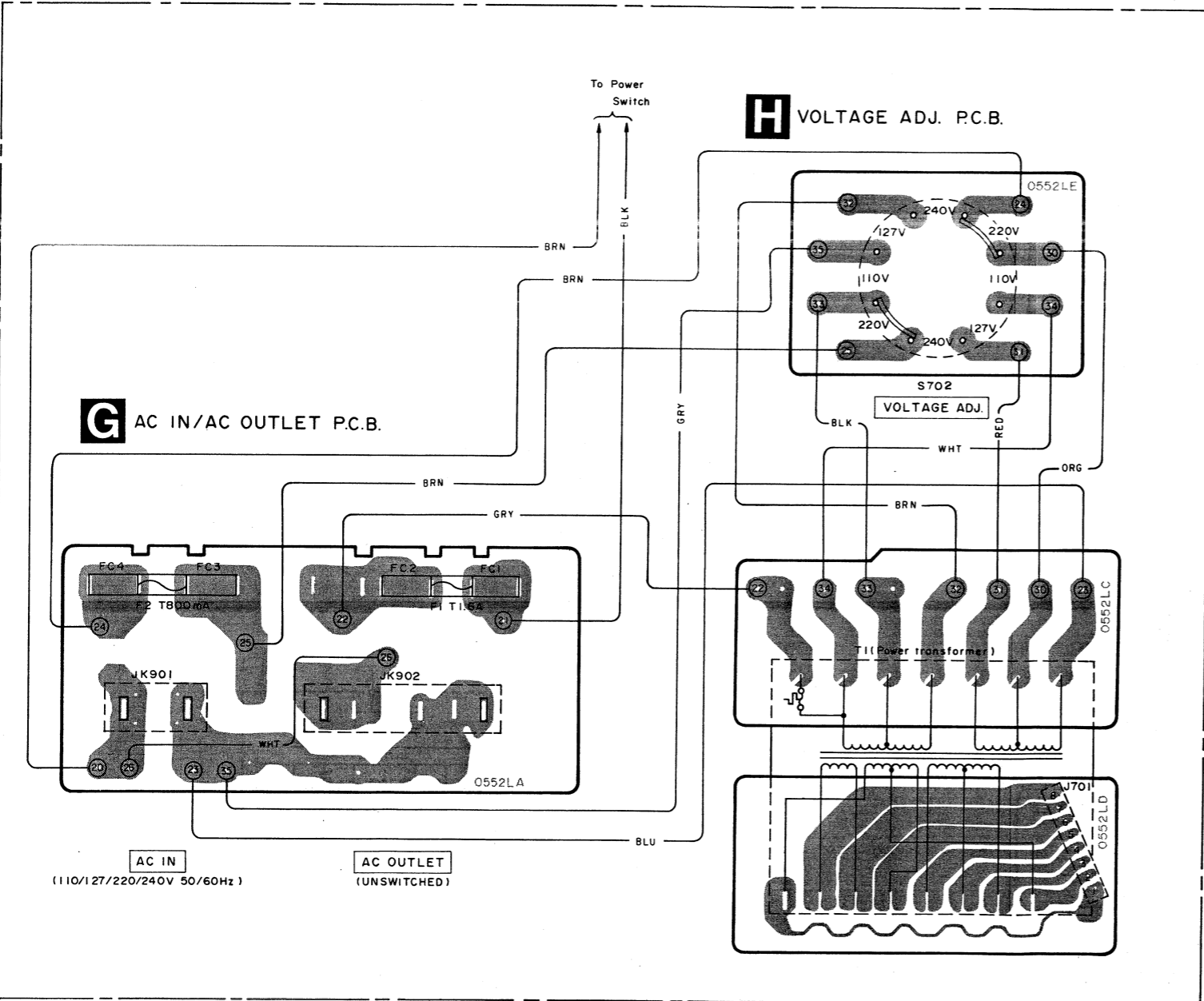

■ TERMINAL GUIDE OF IC'S, TRANSISTOR AND DIODES

<p>AN6558SFE2</p>	<p>BA4558FDXT1</p>	<p>AN6554NSFE2</p>	<p>BU2040F-T2</p>
<p>M5218AP</p>	<p>AN6554F</p>	<p>TC4066B</p>	<p>M5283P</p>
<p>TC9164N</p>	<p>M50754-180SP</p>	<p>SVI3102C</p>	<p>2SB621AQRSTA KSD471ACYGTA</p>
	<p>2SA1309AQSTA 2SC3311AQSTA 2SC3312RSTA 2SD1450STTA UN4215TA</p>		<p>2SD2144STA DTA114ESTP DTC114ESTP DTC144ESTP</p>
<p>2SB1187DEF 2SD1761DEF</p>		<p>MA165TA MA167TA MA700TA 1SS291TA</p>	<p>P300DLF</p>
<p>MA4150MTA MA4240MTA</p>		<p>MA4047MTA MA4051MTA MA4062HTA MA4082MTA</p>	<p>LN873RP-C</p>

■ WIRING CONNECTION DIAGRAM

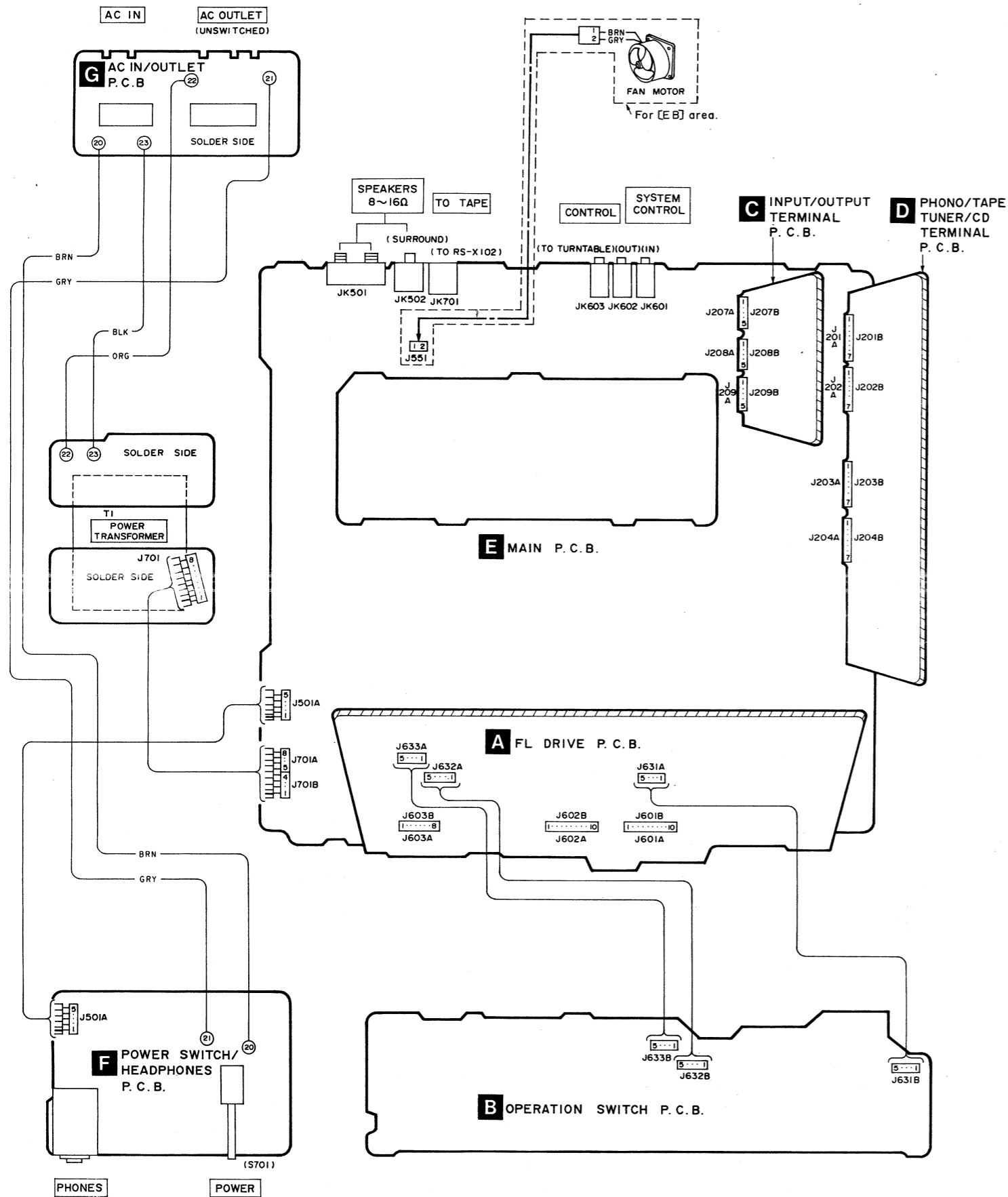

■ BLOCK DIAGRAM

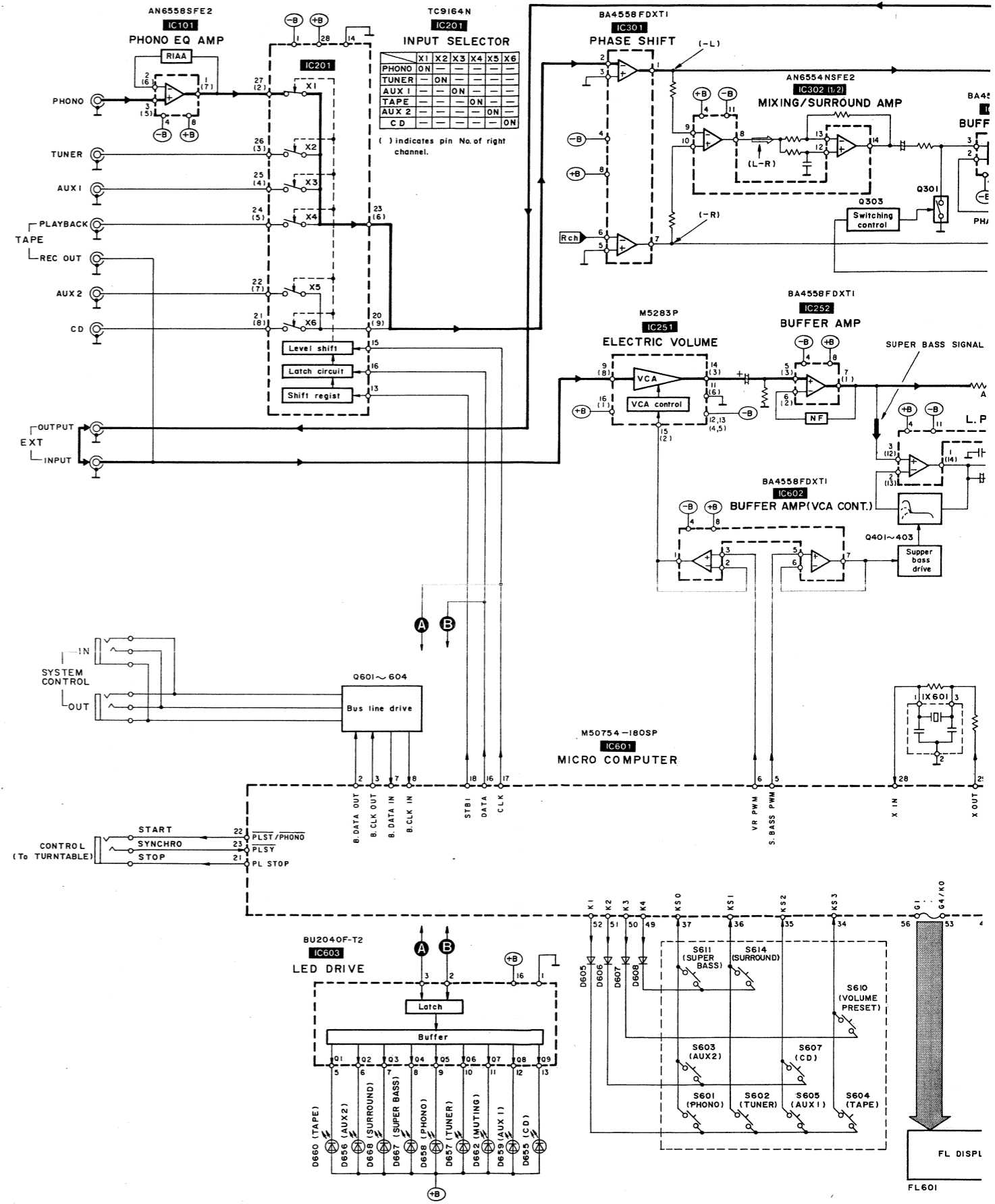

■ BLOCK DIAGRAM

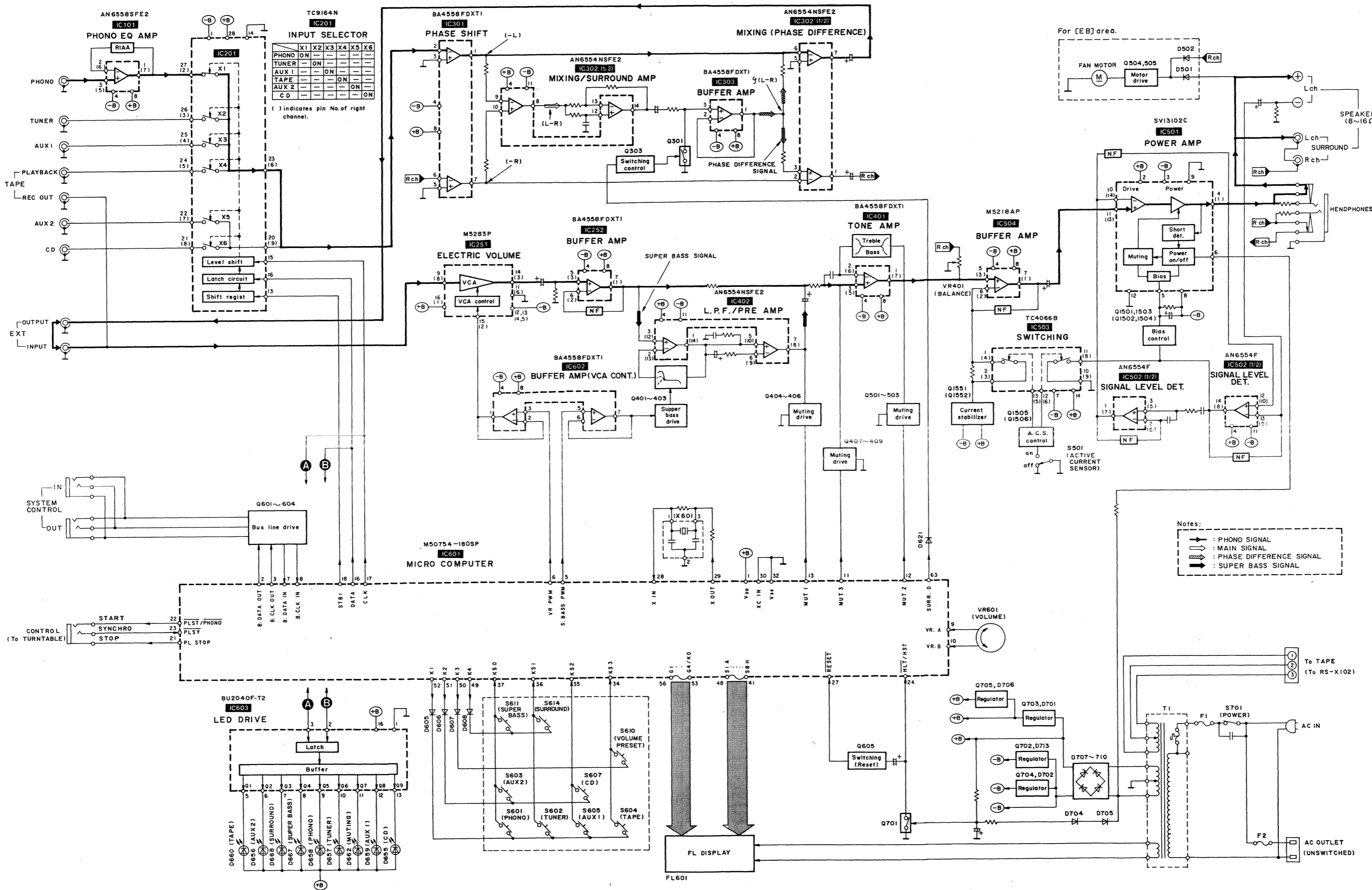

■ FUNCTIONS OF IC TERMINALS

● IC601 (M50754-180SP: MICRO COMPUTER)

Pin No.	Symbol	I/O	Function Description
1	VDD	—	To be connected to a power supply (+5 V).
2	B.DATA OUT	O	This is the output terminal for the bus data signal.
3	B.CLK OUT	O	This is the output terminal for the bus clock signal.
5	S.BASS PWM	O	This is the output terminal for the super bass control signal.
6	VR PWM	O	This terminal outputs the signal for the control of the volume.
7	B.DATA IN	I	This is the input terminal for the bus data signal.
8	B.CLK IN	I	This is the input terminal for the bus clock signal.
9	VR A	I	These are the terminals for the rotary encoder of the volume of VR601.
10	VR B		
11	MUT 3	O	Outputs the -6 dB signal for control of attenuated muting.
12	MUT 2		
13	MUT 1	O	Output the signal for the control of muting.
15	REC M	O	Output the signal for muting the VTR 1 recording.
16	DATA	O	These are output terminal for data and clock signals.
17	CLK		
18	STB 1	O	The serial data inputted into IC201 is latched by the STB pulse and the switch is set to ON according to data.
19	DATA 2	O	These are output terminal for data and clock signals.
20	CLK 2		
21	PLSTOP	I	These are the terminals for sync recording on the player.
22	PLST/PHONO	O	
23	PLSY	I	
24	HLT/HST	I	This is the terminal for the detection of power supply.
25	KS4	I	This is the key scan terminal.
27	RESET	I	This is the input terminal for the reset signal.
28	X IN	I	These are the I/O terminals for the oscillating clock signal.
29	X OUT	O	
34 ? 37	KS 3 ? KS 0	I	These are the key scan terminals.
41 ? 48	S8 ? S1	O	These terminals output signals for the control of the FL display.
49 ?	G5/K4 ?		
56	G1/K0		
63	SURR.D	O	This is the output terminal for the surround signal.

REPLACEMENT PARTS LIST

Notes : * Important safety notice:

 Components identified by Δ mark have special characteristics important for safety. When replacing any of these components use only manufacturer's specified parts.

- * The parenthesized indications in the Remarks columns specify the areas. (Refer to the cover page for area.)
-
- Parts without these indications can be used for all areas.

Ref. No.	Part No.	Part Name & Description	Remarks	Ref. No.	Part No.	Part Name & Description	Remarks
		INTEGRATED CIRCUIT(S)		Q1506	DTA114ESTP	TRANSISTOR	
				Q1551, 1552	2SC3312RSTA	TRANSISTOR	
IC101	AN6558SFE2	I. C, PHONO EQ AMP				DIODE(S)	
IC201	TC9164N	I. C, INPUT SELECTOR		D501, 502	MA167TA	DIODE	(EB)
IC251	M5283P	I. C, ATTENUATOR		D504	MA4051MTA	DIODE	(EB)
IC252	BA4558FDXT1	I. C, BUFFER AMP		D601, 602	MA700	DIODE	
IC301	BA4558FDXT1	I. C, PHASE SHIFT		D603	MA4047MTA	DIODE	
IC302	AN6554NSFE2	I. C, MIXING/SURROUND AMP		D605-608	MA165	DIODE	
IC303	BA4558FDXT1	I. C, BUFFER AMP		D612, 613	MA165	DIODE	
IC401	BA4558FDXT1	I. C, TONE AMP		D615	1SS291TA	DIODE	
IC402	AN6554NSFE2	I. C, L. P. F./PRE AMP		D617, 618	MA165	DIODE	
IC501	SV13102C	I. C, POWER AMP		D620, 621	MA165	DIODE	
IC502	AN6554F	I. C, SIGNAL LEVEL DET.		D655-660	LN873RP-C	LED	
IC503	TC4066B	I. C, SWITCHING		D662	LN873RP-C	LED	
IC504	M5218AP	I. C, BUFFER AMP		D667, 668	LN873RP-C	LED	
IC601	M50754-180SP	I. C, MICRO COMPUTER		D701, 702	MA4150M	DIODE	
IC602	BA4558FDXT1	I. C, BUFFER AMP		D703	MA165	DIODE	
IC603	BU2040F-T2	I. C, LED DRIVE		D704, 705	MA167	DIODE	
		TRANSISTOR(S)		D706	MA4062-H	DIODE	
Q205	2SC3311A-Q	TRANSISTOR		D707-710 Δ	P300DLF	DIODE	
Q206	2SA1309A-R	TRANSISTOR		D713	MA4240H	DIODE	
Q301	2SD2144S	TRANSISTOR		D1501, 1502	MA4082MTA	DIODE	
Q303	DTA114ESTP	TRANSISTOR				VARIABLE RESISTOR(S)	
Q401, 402	2SD2144S	TRANSISTOR		VR401	EWHFDAF20G15	V. R	
Q403	DTA114ESTP	TRANSISTOR		VR601	EVQWQAF2524B	V. R	
Q404	DTA114ESTP	TRANSISTOR		VR1301, 302	EW2XAF20C15	V. R	
Q405-408	2SD2144S	TRANSISTOR				COIL(S)	
Q409	2SA1309A-R	TRANSISTOR		L501, 502	SLQY07G-40	COIL	
Q501, 502	2SD1450STA	TRANSISTOR		L601	ELEXT100KA9	COIL	
Q503	2SA1309A-R	TRANSISTOR		L602, 603	RLQZP101KT-Y	COIL	
Q504	2SC3311AQSTA	TRANSISTOR	(EB)			TRANSFORMER	
Q505	2SA1309AQSTA	TRANSISTOR	(EB)	T1 Δ	RTP1M5E008-V	POWER TRANSFORMER	(E, EG)
Q601	2SC3311A-Q	TRANSISTOR		T1 Δ	RTP1M5B002-V	POWER TRANSFORMER	(EB, GN)
Q602	DTC144EKT96	TRANSISTOR		T1 Δ	RTP1M5G002-V	POWER TRANSFORMER	(GC)
Q603	2SC3311A-Q	TRANSISTOR				OSCILLATOR(S)	
Q604	DTC144EKT96	TRANSISTOR		X601	EF0GC6004T4	CERAMIC FILTER	
Q605	DTC114ESTP	TRANSISTOR					
Q701	UN4215	TRANSISTOR					
Q702	2SB621A-R	TRANSISTOR					
Q703	2SD1761DEF	TRANSISTOR					
Q704	2SB1187DEF	TRANSISTOR					
Q705	KSD471ACYGTA	TRANSISTOR					
Q1501-1504	2SA1309A-R	TRANSISTOR					
Q1505	DTC114ESTP	TRANSISTOR					

Ref. No.	Part No.	Part Name & Description	Remarks	Ref. No.	Part No.	Part Name & Description	Remarks
		DISPLAY TUBE		J603B	RJT003K008M1	CONNECTOR (8P)	
				J631B	SJS50581BB	SOCKET (5P)	
FL601	RSL0074-F	DISPLAY TUBE		J632B	SJS50581BB	SOCKET (5P)	
		FUSE (S)		J633B	SJS50581BB	SOCKET (5P)	
				J701B	RJS1A1704	SOCKET (4P)	
						JACK (S)	
F1 Δ	XBA2C08TB0	FUSE					
F1 Δ	XBA2C16TB0	FUSE	(GC)				
F2 Δ	XBA2C08TB0	FUSE	(E, EB, EG)				
		SWITCH(ES)					
S501	RSS2B006-M	SW, ACTIVE CURRENT SENSOR		JK201	SJF3068N	TERMINAL, PHONO	
S601	EVQ21405R	SW, SPEAKER ON/OFF		JK202	SJF3069-5N	TERMINAL, TAPE	
S602	EVQ21405R	SW, TUNER		JK203	SJF3069N	TERMINAL, TUNER/CD	
S603	EVQ21405R	SW, AUX 2		JK205	SJF3069-5N	TERMINAL, AUX 1/2	
S604	EVQ21405R	SW, TAPE		JK206	SJF3069N	TERMINAL, EXT OUT/IN	
S605	EVQ21405R	SW, AUX 1		JK501	RJR0054M	TERMINZL, SPEAKER	
S607	EVQ21405R	SW, CD		JK502	SJF3068-4N	TERMINAL, SURROUND	
S610	EVQ21405R	SW, VOLUME PRESET		JK504	SJJ145A-1	JACK, HEADPHONES	
S611	EVQ21405R	SW, SUPER BASS		JK601	RJJ33T01	SYNCHRO, SYSTEM CONT. IN	
S614	EVQ21405R	SW, SURROUND		JK602	RJJ33T01	SYNCHRO, SYSTEM CONT. OUT	
S701 Δ	ESB8249V	SW, POWER		JK603	RJJ33T01	SYNCHRO, CONTROL TO TURNABL	
S702 Δ	ESE37263	SW, VOLTAGE SELECTOR	(GC)	JK701	RJS1A0203-0	CONNECTOR, TAPE	
		CONNECTOR		JK901 Δ	SJS9231-1B	AC INLET	(E, EB, EG, GC)
J201A	RJU060G07T	SOCKET		JK901 Δ	SJS9234B	AC INLET	(GN)
J202A	RJU060G07T	SOCKET		JK902 Δ	SJS9333B	AC OUTLET	(E, EG)
J203A	RJU060G07T	SOCKET		JK902 Δ	SJS9332B	AC OUTLET	(EB)
J204A	RJU060G07T	SOCKET		JK902 Δ	SJS9233B	AC OUTLET	(GC)
J207A	RJU060G05T	SOCKET				FUSE HOLDER	
J208A	RJU060G05T	SOCKET		FC1, 2 Δ	SJT388	FUSE HOLDER	
J209A	RJU060G05T	SOCKET		FC3, 4 Δ	SJT388	FUSE HOLDER	(E, EB, EG, GC)
J501A	RJS1A1705	CONNECTOR (5P)					
J551	SJT3213	CONNECTOR	(EB)				
J601A	RJU003K010M1	SOCKET (10P)					
J602A	RJU003K010M1	SOCKET (10P)					
J603A	RJU003K008M1	SOCKET (8P)					
J631A	SJT30549BB1	CONNECTOR					
J632A	SJT30549BB1	CONNECTOR					
J633A	SJT30549BB1	CONNECTOR					
J701A	RJS1A1704	SOCKET (4P)					
J201B	RJT060B07	CONNECTOR					
J202B	RJT060B07	CONNECTOR					
J203B	RJT060B07	CONNECTOR					
J204B	RJT060B07	CONNECTOR					
J207B	RJT060B05	CONNECTOR					
J208B	RJT060B05	CONNECTOR					
J209B	RJT060B05	CONNECTOR					
J601B	RJT003K010M1	CONNECTOR (10P)					
J602B	RJT003K010M1	CONNECTOR (10P)					

Notes : * Capacity value are in microfarads (uF) unless specified otherwise, P=Pico-farads (pF) F=Farads (F)
 * Resistance values are in ohms, unless specified otherwise, 1K=1,000 (OHM) , 1M=1,000k(OHM)

Ref. No.	Part No.	Values & Remarks	Ref. No.	Part No.	Values & Remarks	Ref. No.	Part No.	Values & Remarks
		RESISTORS	R413, 414	ERDS2TJ153	1/4W 15K	R550	ERDS2TJ102	1/4W 1K
			R415, 416	ERDS2TJ222	1/4W 2.2K	R551	ERDS2TJ104	1/4W 100K
			R417, 418	ERDS2TJ221	1/4W 220	R554	ERD25FJ470	1/4W 47 Δ
R107, 108	ERDS2TJ471	1/4W 470	R419, 420	ERDS2TJ273	1/4W 27K	R601	ERDS2TJ223	1/4W 22K
R109, 110	ERDS2TJ473	1/4W 47K	R421, 422	ERDS2TJ470	1/4W 47	R602-604	ERDS2TJ393	1/4W 39K
R111, 112	ERDS2TJ331	1/4W 330	R423, 424	ERDS2TJ153	1/4W 15K	R605	ERDS2TJ223	1/4W 22K
R113, 114	ERDS2TJ560T	1/4W 56	R425-428	ERDS2TJ152	1/4W 1.5K	R606-608	ERDS2TJ393	1/4W 39K
R115, 116	ERDS2TJ184T	1/4W 180K	R429, 430	ERDS2TJ333	1/4W 33K	R609-612	ERDS2TJ100	1/4W 10
R117, 118	ERDS2TJ123	1/4W 12K	R431, 432	ERDS2TJ102	1/4W 1K	R613	ERDS2TJ120T	1/4W 12
R119, 120	ERDS2TJ224T	1/4W 220K	R433	ERDS2TJ105T	1/4W 1M	R614	ERDS2TJ150T	1/4W 15
R121, 122	ERDS2TJ102	1/4W 1K	R434	ERDS2TJ334	1/4W 330K	R615, 616	ERDS2TJ151	1/4W 150
R123, 124	ERDS2TJ471	1/4W 470	R435, 436	ERDS2TJ102	1/4W 1K	R617-620	ERDS2TJ104	1/4W 100K
R201, 202	ERDS2TJ472	1/4W 4.7K	R437	ERDS2TJ105T	1/4W 1M	R621, 622	ERDS2TJ103	1/4W 10K
R203-206	ERDS2TJ102	1/4W 1K	R438	ERDS2TJ334	1/4W 330K	R623	ERDS2TJ222	1/4W 2.2K
R207-210	ERDS2TJ822	1/4W 8.2K	R439, 440	ERDS2TJ152	1/4W 1.5K	R624	ERDS2TJ332	1/4W 3.3K
R213, 214	ERDS2TJ822	1/4W 8.2K	R441, 442	ERDS2TJ222	1/4W 2.2K	R625	ERDS2TJ103	1/4W 10K
R215-218	ERDS2TJ102	1/4W 1K	R443, 444	ERDS2TJ102	1/4W 1K	R626	ERDS2TJ332	1/4W 3.3K
R232, 233	ERDS2TJ272T	1/4W 2.7K	R445	ERDS2TJ222	1/4W 2.2K	R627	ERDS2TJ222	1/4W 2.2K
R249	ERDS2TJ103	1/4W 10K	R446	ERDS2TJ104	1/4W 100K	R628	ERDS2TJ332	1/4W 3.3K
R250	ERDS2TJ223	1/4W 22K	R447	ERDS2TJ334	1/4W 330K	R629	ERDS2TJ103	1/4W 10K
R251, 252	ERDS2TJ473	1/4W 47K	R448	ERDS2TJ105T	1/4W 1M	R630	ERDS2TJ102	1/4W 1K
R253, 254	ERDS2TJ183T	1/4W 18K	R449	ERDS2TJ332	1/4W 3.3K	R631	ERDS2TJ103	1/4W 10K
R255, 256	ERDS2TJ153	1/4W 15K	R450	ERDS2TJ103	1/4W 10K	R632	ERDS2TJ222	1/4W 2.2K
R257, 258	ERDS2TJ473	1/4W 47K	R471-474	ERDS2TJ334	1/4W 330K	R633	ERDS2TJ103	1/4W 10K
R271, 272	ERDS2TJ152	1/4W 1.5K	R477, 478	ERDS2TJ102	1/4W 1K	R634	ERDS2TJ822	1/4W 8.2K
R297, 298	ERDS2TJ182	1/4W 1.8K	R500	ERDS2TJ100	1/4W 10	R635	ERDS2TJ393	1/4W 39K
R301-304	ERDS2TJ223	1/4W 22K	R501	ERDS2TJ104	1/4W 100K	R636	ERDS2TJ332	1/4W 3.3K
R305, 306	ERDS2TJ224T	1/4W 220K	R502	ERDS2TJ105T	1/4W 1M	R637	ERDS2TJ103	1/4W 10K
R307, 308	ERDS2TJ332	1/4W 3.3K	R507, 508	ERDS2TJ222	1/4W 2.2K	R638	ERDS2TJ104	1/4W 100K
R309, 310	ERDS2TJ223	1/4W 22K	R509, 510	ERDS2TJ563	1/4W 56K	R639	ERDS2TJ105T	1/4W 1M
R311, 312	ERDS2TJ393	1/4W 39K	R511, 512	ERDS2TJ182	1/4W 1.8K	R640	ERDS2TJ102	1/4W 1K
R313-315	ERDS2TJ223	1/4W 22K	R513, 514	ERDS2TJ563	1/4W 56K	R641	ERDS2TJ223	1/4W 22K
R316	ERDS2TJ622T	1/4W 6.2K	R515, 516	ERDS2TJ223T	1/4W 22K (EB)	R642	ERDS2TJ103	1/4W 10K
R317	ERDS2TJ562	1/4W 5.6K	R517	ERDS2TJ563T	1/4W 56K (EB)	R643	ERDS2TJ105T	1/4W 1M
R318	ERDS2TJ123	1/4W 12K	R518	ERDS2TJ684	1/4W 680K	R646	ERDS2TJ223	1/4W 22K
R319	ERDS2TJ224T	1/4W 220K	R519	ERDS2TJ154	1/4W 150K	R653-655	ERDS2TJ331	1/4W 330
R321, 322	ERDS2TJ332	1/4W 3.3K	R520	ERDS2TJ153T	1/4W 15K (EB)	R659	ERDS2TJ272T	1/4W 2.7K
R324	ERDS2TJ332	1/4W 3.3K	R521	ERDS2TJ103T	1/4W 10K (EB)	R661	ERDS2TJ331	1/4W 330
R325, 326	ERDS2TJ392T	1/4W 3.9K	R522	ERDS1FVJ680T	1/2W 68 (EB) Δ	R662	ERDS2TJ101	1/4W 100
R327, 328	ERDS2TJ104	1/4W 100K	R524	ERDS2TJ105T	1/4W 1M	R697-699	ERDS2TJ101	1/4W 100
R329	ERDS2TJ332	1/4W 3.3K	R525, 526	ERD25FVJ100T	1/4W 10 Δ	R701, 702	ERDS1FVJ332T	1/2W 3.3K Δ
R331	ERDS2TJ105T	1/4W 1M	R527, 528	ERDS1FVJ100T	1/2W 10 Δ	R703	ERD25FJ101	1/4W 100 Δ
R332	ERDS2TJ334	1/4W 330K	R531, 532	ERG2SJ331P	2W 330	R704	ERDS2TJ473	1/4W 47K
R401, 402	ERDS2TJ823T	1/4W 82K	R533, 534	ERDS2TJ562	1/4W 5.6K	R705	ERDS2TJ103	1/4W 10K
R403, 404	ERDS2TJ683	1/4W 68K	R535-538	ERDS2TJ472	1/4W 4.7K	R706	ERDS1FVJ2R2T	1/2W 2.2 Δ
R405, 406	ERDS2TJ393	1/4W 39K	R539	ERDS2TJ102	1/4W 1K	R707	ERDS1FVJ3R3T	1/2W 3.3 Δ
R407, 408	ERDS2TJ333	1/4W 33K	R540	ERDS2TJ334	1/4W 330K	R709	ERDS2TJ332	1/4W 3.3K
R409, 410	ERDS2TJ103	1/4W 10K	R542	ERDS2TJ103	1/4W 10K	R710	ERDS1FVJ331T	1/2W 330 Δ
R411, 412	ERDS2TJ332	1/4W 3.3K	R543	ERDS1FVJ560T	1/2W 56 (EB) Δ	R711	ERDS2TJ102	1/4W 1K

Ref. No.	Part No.	Values & Remarks	Ref. No.	Part No.	Values & Remarks	Ref. No.	Part No.	Values & Remarks
R713	ERDS2TJ2R2T	1/4W 2.2	C221-226	ECBT1H101KB5	50V 100P	C537, 538	ECBT1H102KB5	50V 1000P
R718	ERDS1FVJ820T	1/2W 82 Δ	C229, 230	ECBT1H101KB5	50V 100P	C543, 544	ECBT1H102KB5	50V 1000P
R727	ERDS2TJ104	1/4W 100K	C231, 232	ECBT1E103ZF	25V 0.01U	C597, 598	ECBT1H102KB5	50V 1000P
R1301, 1302	ERDS2TJ102	1/4W 1K	C250	ECEA1CKA220B	16V 22U	C601	ECBT1E103ZF	25V 0.01U
R1303, 1304	ERDS2TJ822	1/4W 8.2K	C251, 252	ECEA1HKA3R3B	50V 3.3U	C602	ECEA0JU102	6.3V 1000U
R1305, 1306	ERDS2TJ223	1/4W 22K	C253, 254	ECEA1HKA47B	50V 0.47U	C603	ECEA1HKA3R3B	50V 3.3U
R1307, 1308	ERDS2TJ392T	1/4W 3.9K	C255, 256	ECBT1H180J5	50V 18P	C604	ECEA1VKA100B	35V 10U
R1309, 1310	ERDS2TJ182	1/4W 1.8K	C258	ECBT1E223ZF	25V 0.022U	C605	ECBT1E103ZF	25V 0.01U
R1311, 1312	ERDS2TJ821	1/4W 820	C271, 272	ECBT1H101KB5	50V 100P	C606, 607	ECEA1HKA010B	50V 1U
R1313, 1314	ERDS2TJ333	1/4W 33K	C273, 274	ECEA1CKA220B	16V 22U	C608	ECBT1H101KB5	50V 100P
R1501, 1502	ERDS2TJ123	1/4W 12K	C297, 298	ECBT1H151KB5	50V 150P	C651	ECBT1H104ZF5	50V 0.1U
R1503, 1504	ERDS2TJ103	1/4W 10K	C301, 302	ECA1HAP3R3B	50V 3.3U	C653	ECBT1H470J5	50V 47P
R1505, 1506	ERDS2TJ101	1/4W 100	C303	ECBT1H680J5	50V 68P	C700	ECKWNS103ZV	500V 0.01U Δ
R1507, 1508	RREEMKR10VC	2W 0.1	C304	ECQV1H823JZ	50V 0.082U	C701	ECBT1H102KB5	50V 1000P
R1509-1512	ERDS2TJ103	1/4W 10K	C305	ECEA1HKA3R3B	50V 3.3U	C702	ECKR1H103ZF5	50V 0.01U
R1513-1516	ERDS2TJ104	1/4W 100K	C306	ECBT1H221KB5	50V 220P	C703, 704	ECEA1EKA100B	25V 10U
R1517, 1518	ERDS2TJ472	1/4W 4.7K	C307	ECEA1HKA3R3B	50V 3.3U	C705, 706	ECEA1CKA100B	16V 10U
R1519, 1520	ERDS2TJ272T	1/4W 2.7K	C309, 310	ECBT1H820KB5	50V 82P	C707	ECBT1E103ZF	25V 0.01U
R1521-1526	ERDS2TJ563	1/4W 56K	C311, 312	ECA1HAP3R3B	50V 3.3U	C708	ECEA1CKA100B	16V 100U
R1527, 1528	ERDS2TJ103	1/4W 10K	C313, 314	ECBT1E103ZF	25V 0.01U	C709	ECEA1HKA2R2B	50V 2.2U
R1529, 1530	ERDS2TJ392T	1/4W 3.9K	C395, 396	ECBT1H120J5	50V 12P	C710	ECBT1E223ZF	25V 0.022U
R1531, 1532	ERDS2TJ223	1/4W 22K	C398, 399	ECBT1E103ZF	25V 0.01U	C711, 712	ECEA1HJ332UB	50V 3300U
R1533, 1534	ERDS2TJ472	1/4W 4.7K	C411, 412	ECFR1E123KR	25V 0.012U	C713	ECQE1104KF3	100V 0.1U
R1535, 1536	ERDS2TJ223	1/4W 22K	C413, 414	ECEA1HKA2R2B	50V 0.22U	C715	ECEA1VKA100B	35V 10U
R1537, 1538	ERDS2TJ103	1/4W 10K	C415, 416	ECFR1E682KR	25V 6800P	C731	ECFR1E104ZF5	25V 0.1U
R1539	ERDS2TJ333	1/4W 33K	C417, 418	ECFR1E272KR	25V 2700P	C1301, 1302	ECFR1E123KR	25V 0.012U
R1540	ERDS2TJ102	1/4W 1K	C419, 420	ECFR1E333KR	25V 0.033U	C1303, 1304	ECFR1E683KR	25V 0.068U
R1541, 1542	ERDS2TJ752T	1/4W 7.5K	C421, 422	ECEA1HKA3R3B	50V 3.3U	C1305, 1306	ECFR1E472KR	25V 4700P
R1551, 1552	ERDS2TJ223	1/4W 22K	C423, 424	ECA1HAP100B	50V 10U	C1307, 1308	ECFR1E223KR	25V 0.022U
R1553, 1554	ERDS2TJ103	1/4W 10K	C427	ECEA0JKA470B	6.3V 47U	C1309, 1310	ECA1HAP010B	50V 1U
R1555, 1556	ERDS2TJ562	1/4W 5.6K	C432	ECEA1CKA100B	16V 10U	C1501-1504	ECEA1HKA2R2B	50V 2.2U
R1557, 1558	ERDS2TJ103	1/4W 10K	C433, 434	ECBT1E103ZF	25V 0.01U	C1505, 1506	ECFR1E223KR	25V 0.022U
R1559, 1560	ERDS2TJ273	1/4W 27K	C451, 452	ECEA1CKA220B	16V 22U	C1507, 1508	ECBT1H820KB5	50V 82P
R1561-1564	ERDS2TJ102	1/4W 1K	C471, 472	ECA1HAP3R3B	50V 3.3U	C1509-1512	ECFR1E104KR	25V 0.1U
R1565, 1566	ERDS2TJ123	1/4W 12K	C473, 474	ECBT1H101KB5	50V 100P	C1513, 1514	ECBT1H331KB5	50V 330P
R1567, 1568	ERDS2TJ683	1/4W 68K	C475, 476	ECBT1H821KB5	50V 820P	C1515, 1516	ECBT1C103MS5	16V 0.01U
			C477, 478	ECBT1H680J5	50V 68P	C1517, 1518	ECBT1E103ZF	25V 0.01U
			C479, 480	ECEA1HKA3R3B	50V 3.3U	C1521A	ECA1HAP2R2B	50V 2.2U
		CAPACITORS	C483, 484	ECBT1E103ZF	25V 0.01U	C1521	ECBT1H102KB5	50V 1000P
			C501, 502	ECBT1H331KB5	50V 330P	C1522A	ECA1HAP2R2B	50V 2.2U
C107, 108	ECBT1H101KB5	50V 100P	C503, 504	ECBT1H151KB5	50V 150P	C1522	ECBT1H102KB5	50V 1000P
C109, 110	ECBT1H102KB5	50V 1000P	C505, 506	ECA1HAP2R2B	50V 2.2U	C1551, 1552	ECA1HAP3R3B	50V 3.3U
C111, 112	ECA1EAP330B	25V 33P	C507, 508	ECBT1H6R8K5	50V 6.8P	C1553, 1554	ECBT1H151KB5	50V 150P
C115, 116	ECFR1E223KR	25V 0.022U	C509, 510	ECKT1H223ZF	50V 0.022U	C1555, 1556	ECEA1HKA2R2B	50V 2.2U
C117, 118	ECFR1E682KR	25V 6800P	C513	ECEA1CKA100B	16V 10U (EB)	C1557, 1558	ECQV1H124JZ3	50V 0.12U
C119, 120	ECA1HAP010B	50V 1U	C514	ECEA0JKA470B	6.3V 47U	C1559, 1560	ECBT1E103ZF	25V 0.01U
C121, 122	ECBT1E103ZF	25V 0.01U	C516-518	ECBT1E103ZF	25V 0.01U			
C200	ECBT1E223ZF	25V 0.022U	C519	ECA1HAP330B	55V 33U			
C201	ECBT1H470J5	50V 47P	C520	ECA2AAP100B	100V 10U			
C203, 204	ECBT1E103ZF	25V 0.01U	C523, 524	ECA1HAP3R3B	50V 3.3U			
C205, 206	ECBT1H180J5	50V 18P	C525, 526	ECBT1H331KB5	50V 330P			
C207, 208	ECBT1H151KB5	50V 150P	C535, 536	ECBT1E223ZF	25V 0.022U			
C209-216	ECBT1H101KB5	50V 100P						

5524

Service Manual

Amplifier

SU-X120

Simplified

Stereo Integrated Amplifier

Colour

(K) Black Type

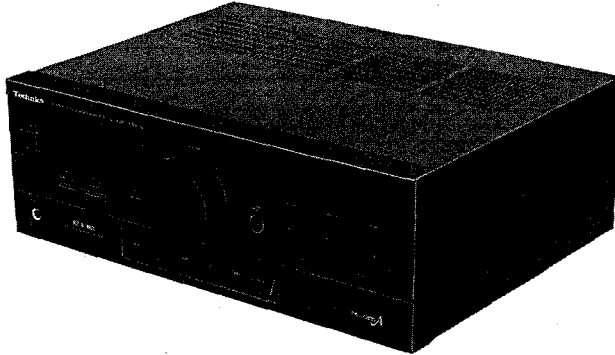

Areas

Suffix for Model No.	Area	Colour
(E)	Europe	(K)
(EB)	Great Britain	
(EG)	Germany and Italy	
(GN)	Oceania	

• Please file and use this manual together with the Service Manual for Model No. SU-X102, Order No. AD9103049C8.
 • This service manual indicates the main differences between Original SU-X102 (E). + (SOM) 1/15/17/15

■ LINE-UP OF COMPONENTS

System Name	Unit
SC-X120 (E)	ST-X302LA (E) : Tuner
	SU-X120 (E) : Amplifier
	RS-X120 (EG) : Cassette Deck
	— : CD Player
	SL-J110R (E) : Turntable
	SB-CS55 (E) : Speaker (Made in PAES)
SC-X120 (EB)	ST-X302LA (EB) : Tuner
	SU-X120 (EB) : Amplifier
	RS-X120 (EG) : Cassette Deck
	SL-PJ28A (EB) : CD Player (Made in MBV)
	SL-J110R (EB) : Turntable
	SB-CS55 (E) : Speaker (Made in PAES)
SC-X120 (EF)	ST-X302LA (EF) : Tuner (Made in PFS)
	SU-X120 (E) : Amplifier
	RS-X120 (EG) : Cassette Deck
	SL-PJ28A (E) : CD Player (Made in MBV)
	SL-J110R (E) : Turntable
	SB-CS55 (E) : Speaker (Made in PAES)

System Name	Unit
SC-X120 (EG)	ST-X302LA (EG) : Tuner
	SU-X120 (EG) : Amplifier
	RS-X120 (EG) : Cassette Deck
	SL-PJ28A (EG) : CD Player (Made in MBV)
	SL-J110R (EG) : Turntable
	SB-CS55 (E) : Speaker (Made in PAES)
SC-X120 (EI)	ST-X302LA (EI) : Tuner (Made in PFS)
	SU-X120 (EG) : Amplifier
	RS-X120 (EG) : Cassette Deck
	SL-PJ28A (EG) : CD Player (Made in MBV)
	SL-J110R (EG) : Turntable
	SB-CS55 (E) : Speaker (Made in PAES)
SC-X120 (GN)	ST-X302LA (GN) : Tuner
	SU-X120 (GN) : Amplifier
	RS-X120 (GC) : Cassette Deck
	SL-PJ28 (GN) : CD Player
	SL-J110R (GN) : Turntable
	SB-CD120 (GC) : Speaker

■ CHANGE IN REPLACEMENT PARTS LIST

SU-X102 (Pages 30~33, 36 of service manual.)

Ref. No.	Part Number		Description	Remarks
	SU-X102 (E)	SU-X120 (E, EB, EG, GN)		
TRANSISTOR(S)				
Q504	—	2SC3311AQSTA	TRANSISTOR	(EB)
Q505	—	2SA1309AQSTA	TRANSISTOR	(EB)
DIODE(S)				
D501, 502	—	MA167TA	DIODE	(EB)
D504	—	MA4051MTA	DIODE	(EB)
TRANSFORMER(S)				
T1	RTP1M5E008-V	RTP1M5B002-V	POWER TRANSFORMER	Δ (EB, GN)
FUSE(S)				
F2	XBA2C08TB0	—	FUSE	Δ (GN)
CONNECTOR(S)				
J551	—	SJT3213	CONNECTOR (2P)	(EB) Type (B)
JACK(S)				
JK901	SJS9231-1B	SJS9234B	AC INLET	Δ (GN)
JK902	SJS9333B	SJS9332B	AC OUTLET	Δ (EB)
		—	AC OUTLET	Δ (GN)
FUSE HOLDER(S)				
FC 3, 4	SJT388	—	FUSE HOLDER	Δ (GN)
RESISTORS				
R515, 516	—	ERDS2TJ223T	RESISTOR ¼ W 22K	(EB)
R517	—	ERDS2TJ563T	RESISTOR ¼ W 56K	(EB)
R520	—	ERDS2TJ153T	RESISTOR ¼ W 15K	(EB)
R521	—	ERDS2TJ103T	RESISTOR ¼ W 10K	(EB)
R522	—	ERDS1FVJ680T	RESISTOR ½ W 68	Δ (EB)
R543	—	ERDS1FVJ560T	RESISTOR ½ W 56	Δ (EB)
CAPACITORS				
C513	—	ECEA1CKA100B	CAPACITOR 16 V 10 μ	(EB)
C709	ECEA1HKA2R2B	ECEA1HKN2R2B	CAPACITOR 50 V 2.2 μ	
CABINET PARTS				
3	SJP9205-2Y	SJP9205-2T	CABINET	
5	SJS9231A	SJS9234A	AC INLET COVER	(GN)
6	SJS9333A	SJS9332A	AC OUTLET COVER	(EB)
		RJS1A4602	AC OUTLET COVER	(GN)
7	RGR0105K-A1	RGR0105K-C1	REAR PANEL	(E)
		RGR0105T-B	REAR PANEL	(EB) Type (A)
		RGR0105F-D1	REAR PANEL	(EB) Type (B)
		RGR0105K-D1	REAR PANEL	(EG)
		RGR0105M-A1	REAR PANEL	(GN)
19	RGU0591A-K	RGU0591B-K	BUTTON, SUPER BASS	
20	RFKGUX102E	RFKGUX120E-K	FRONT PANEL ASS'Y	
25	—	REM0020-1	FAN MOTOR ASS'Y	(EB) Type (A)
		SYE1128-4	FAN MOTOR ASS'Y	(EB) Type (B)
25-1	—	SHE232-1	FAN	(EB) Type (A)
		SHE232	FAN	(EB) Type (B)
25-2	—	SUS271	SPRING	(EB)
25-3	—	RMQ0209-K	FAN CASE	(EB) Type (A)
		SHE233-1	FAN CASE	(EB) Type (B)
25-4	—	MDN-4RB4MRC	MOTOR	(EB)
25-5	—	RMQ0208-K	CAP	(EB) Type (A)
		SHE234	CAP	(EB) Type (B)
25-6	—	SJT783	TERMINAL	(EB) Type (B)
25-7	—	SJS5215	CONNECTOR (2P)	(EB) Type (B)
25-8	—	RMQ0212-K	TERMINAL CAP	(EB) Type (A)
36	—	RJS1A7402	CONNECTOR (2P)	(EB) Type (A)
37	—	XTBS3+8JFZ1	SCREW	(EB) Type (A)

Service Manual

Amplifier

SU-X120

Stereo Integrated Amplifier

Simplified

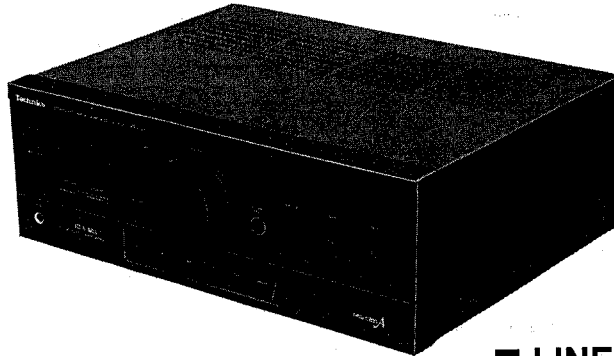

Colour

(K) Black Type

Area

Suffix for Model No.	Area	Colour
(GC)	Asia, Latin America, Middle Near East and Africa.	(K)

■ LINE-UP OF COMPONENTS

System Name	Unit
SC-X120 (GC)	ST-X302LA (GC) : Tuner
	SU-X120 (GC) : Amplifier
	RS-X120 (GC) : Cassette Deck
	SL-PJ28 (GC) : CD Player
	SL-J110R (GC) : Turntable
	SB-CD120 (GC) : Speaker

- Please file and use this manual together with the Service Manual for Model No. SU-X102 Order No. AD9103049C8.
- This service manual indicates the main differences between Original SU-X102 (GC).

■ CHANGE IN REPLACEMENT PARTS LIST SU-X102 (Pages 33, 36 of service manual.)

Note: • Important safety notice: Components identified by Δ mark have special characteristics important for safety. Furthermore, special parts which have purposes of fire-retardant (resistors), high-quality sound (capacitors), low-noise (resistors), etc. are used.
When replacing any of components, be sure to use only manufacturer's specified parts shown in the parts list.

Ref. No.	Part Number		Description	Remarks
	SU-X102 (GC)	SU-X120 (GC)		
CAPACITORS				
C709	ECEA1HKA2R2B	ECEA1HKN2R2B	CAPACITOR 50 V 2.2 μ	
CABINET PARTS				
3	SJP9205-2Y	SJP9205-2T	SHORTING PIN	
7	RGR0105L-1	RGR0105L-A1	REAR PANEL	
19	RGU0591A-K	RGU0591B-K	BUTTON, SUPPER BASS	
20	RFKGUX102E	RFKGUX120E-K	FRONT PANEL ASS'Y	
PACKING MATERIALS				
P1	RPG0838	RPG1208	PACKING CASE	
P3	SPSD152	—	ACCESSORY BOX	Deletion
ACCESSORIES				
A1	RQF1084	—	INSTRUCTIONS MANUAL ASS'Y	Deletion
A1-3	RQT0986-G	RQT1495-G	INSTRUCTIONS MANUAL	
A2	RJA0004	—	AC POWER SUPPLY CORD	Δ Deletion
A3	SJP9215	—	AC PLUG ADAPTOR	Δ Deletion

Technics

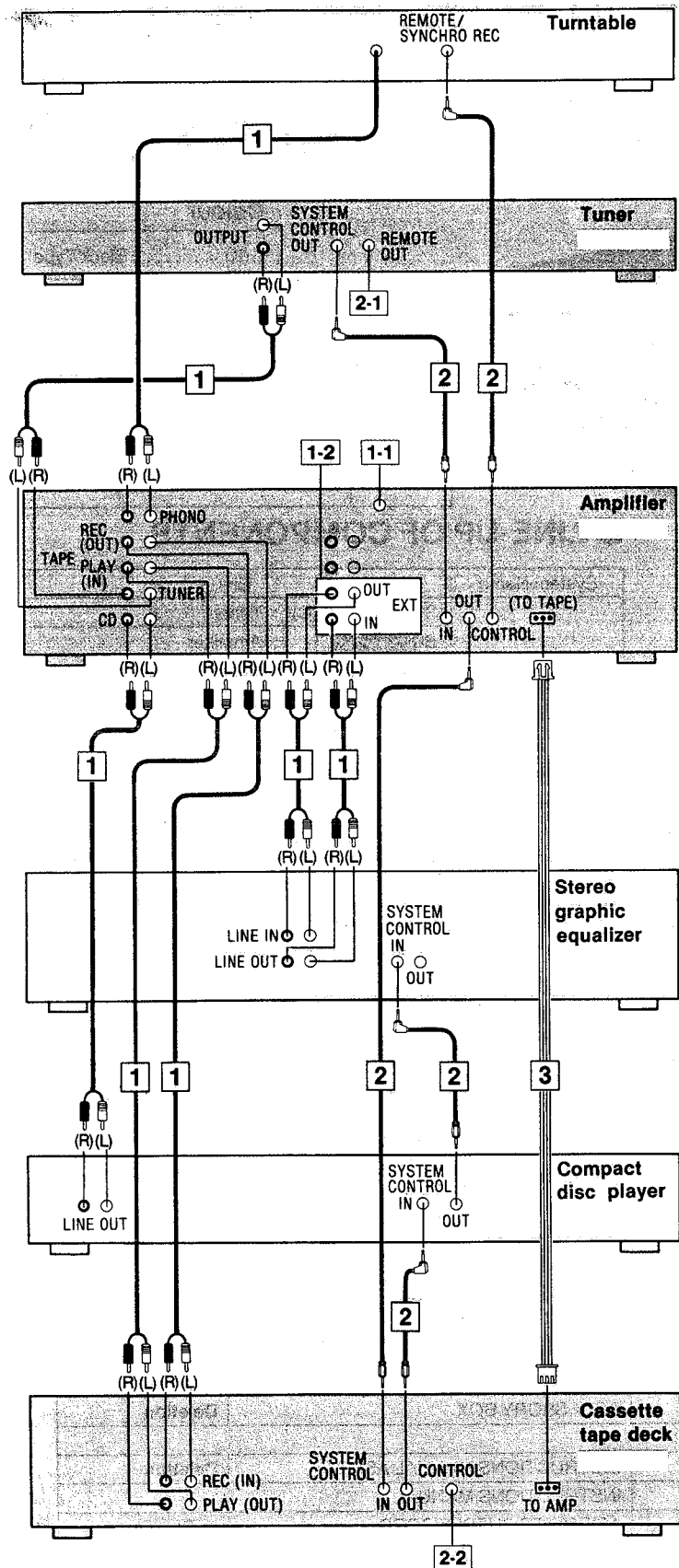

■ CONNECTIONS OF EACH UNIT



Connection diagrams shown are for connections to a Technics hi-fi component system. Make connections in the numbered sequential order.

- 1** **Connect the stereo connection cables** (included with the turntable, tuner, stereo graphic equalizer, and cassette tape deck).

Stereo connection cable

White (L) 
Red (R) 

1-1

"GND" terminal of the amplifier

This terminal is for use with a turntable which has a ground wire.

1-2

"EXT" terminals of the amplifier

When these terminals are not in use, be sure to insert the "shorting" pins.

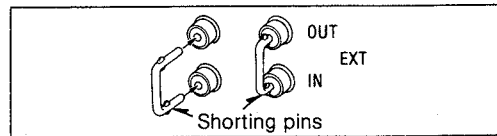

- 2** **Connect the L-type cables** (included with the turntable, tuner, stereo graphic equalizer, compact disc player, and cassette tape deck).

2-1

"REMOTE OUT" terminal

This terminal is used to connect to the "REMOTE IN" terminal of the Technics multi-compact disc player.

2-2

"CONTROL" terminal

Make a connection from this terminal to the "CONTROL" terminal for a cassette deck on a Technics multi compact disc player.

(For detailed information, refer to the operating instructions of the Technics multi compact disc player.)

- 3** **Connect the 3-core flat cable** (included with the cassette tape deck).

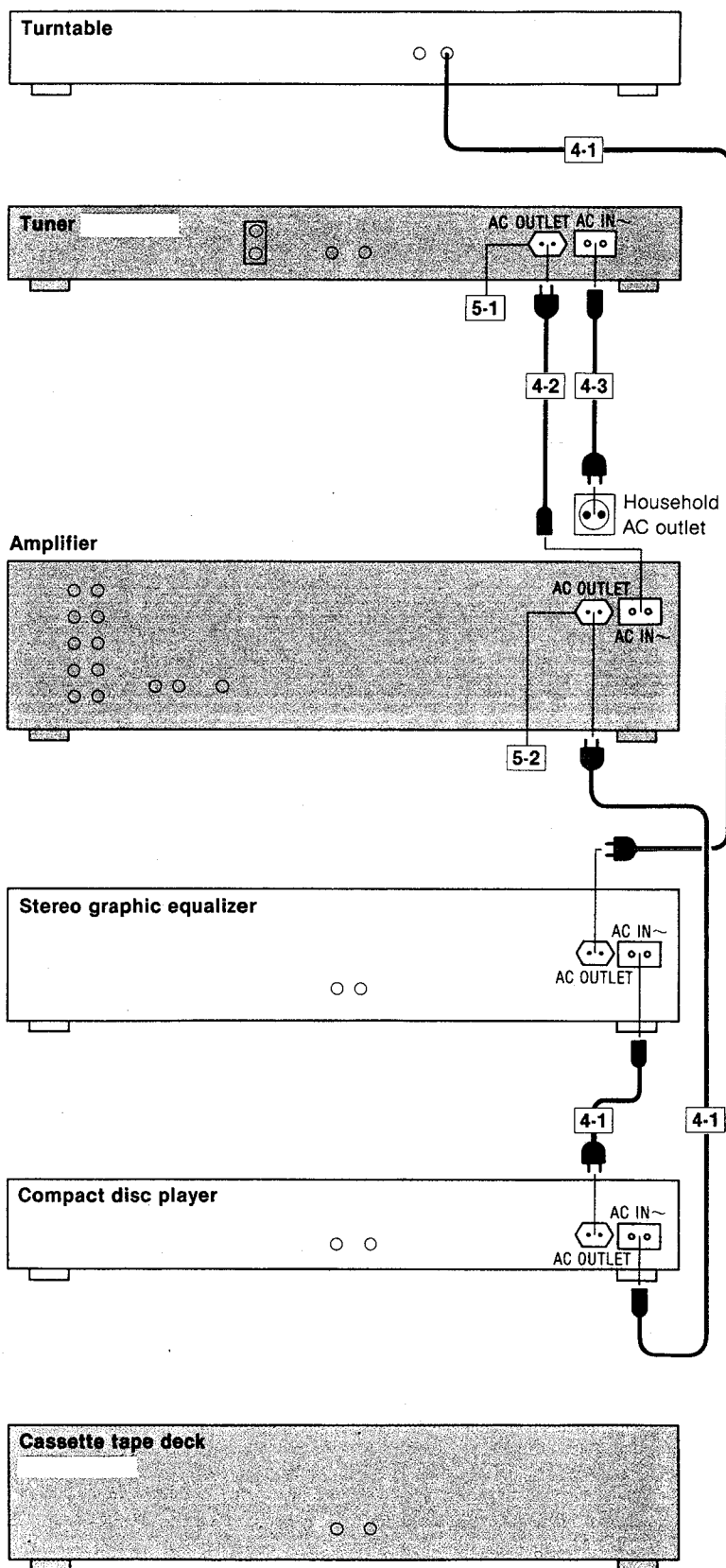

4 Connect the AC power supply cords.

- 4-1** Connect the AC power supply cords.
- 4-2** Connect the AC power supply cord (short for continental Europe).
- 4-3** Connect the AC power supply cord (long for continental Europe).

Connect this cord only after all other cables have been connected.

For areas except continental Europe

If the power plug will not fit your socket, use the power plug adaptor.



Notes:

- Configuration of the AC outlets and AC power supply cords differ according to area.
- If the compact disc player is not used in combination with these components, connect the AC power supply cord of the stereo graphic equalizer to the AC outlet of the amplifier.

5 "AC OUTLET"

5-1 "SWITCHED" outlet

Power is controlled by the power switch. Audio equipment rated up to 500 W can be connected here.

5-2 "UNSWITCHED" outlet:

Power is always available, regardless of power switch. Audio equipment rated up to 60 W can be connected here.

Note:

If other audio equipments are to be connected to these outlets, make sure that the total power consumption does not exceed the rating of each outlet.

After other units have been connected, tie up the cords in a bundle with a clip, etc. and place them behind the units.

Service Manual

Amplifier

SU-X120

Stereo Integrated Amplifier

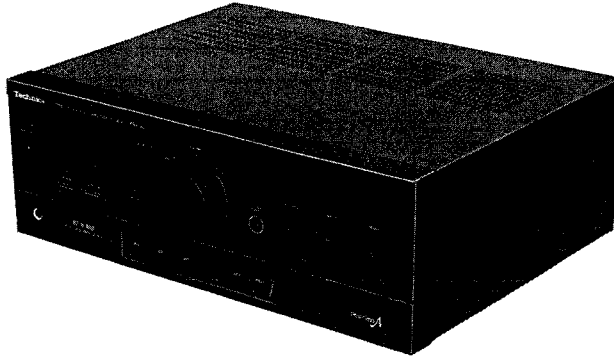
Simplified

Colour

(K) Black Type

Areas

Suffix for Model No.	Area	Colour
(E)	Europe	(K)
(EB)	Great Britain	
(EG)	Germany and Italy	
(GN)	Oceania	

- Please file and use this manual together with the Service Manual for Model No. SU-X102, Order No. AD9103049C8.
- This service manual indicates the main differences between Original SU-X102 (E).

■ LINE-UP OF COMPONENTS

System Name	Unit
SC-X120 (E)	ST-X302LA (E) : Tuner
	SU-X120 (E) : Amplifier
	RS-X120 (EG) : Cassette Deck
	— : CD Player
	SL-J110R (E) : Turntable
SC-X120 (EB)	SB-CS55 (E) : Speaker (Made in PAES)
	ST-X302LA (EB) : Tuner
	SU-X120 (EB) : Amplifier
	RS-X120 (EG) : Cassette Deck
	SL-PJ28A (EB) : CD Player (Made in MBV)
SC-X120 (EF)	SL-J110R (EB) : Turntable
	SB-CS55 (E) : Speaker (Made in PAES)
	ST-X302LA (EF) : Tuner (Made in PFS)
	SU-X120 (E) : Amplifier
	RS-X120 (EG) : Cassette Deck
SC-X120 (GN)	SL-PJ28A (E) : CD Player (Made in MBV)
	SL-J110R (E) : Turntable
	SB-CS55 (E) : Speaker (Made in PAES)
	SB-CD120 (GC) : Speaker

System Name	Unit
SC-X120 (EG)	ST-X302LA (EG) : Tuner
	SU-X120 (EG) : Amplifier
	RS-X120 (EG) : Cassette Deck
	SL-PJ28A (EG) : CD Player (Made in MBV)
	SL-J110R (EG) : Turntable
SC-X120 (EI)	SB-CS55 (E) : Speaker (Made in PAES)
	ST-X302LA (EI) : Tuner (Made in PFS)
	SU-X120 (EG) : Amplifier
	RS-X120 (EG) : Cassette Deck
	SL-PJ28A (EG) : CD Player (Made in MBV)
SC-X120 (GN)	SL-J110R (EG) : Turntable
	SB-CS55 (E) : Speaker (Made in PAES)
	ST-X302LA (GN) : Tuner
	SU-X120 (GN) : Amplifier
	RS-X120 (GC) : Cassette Deck
SC-X120 (GN)	SL-PJ28 (GN) : CD Player
	SL-J110R (GN) : Turntable
	SB-CD120 (GC) : Speaker

Technics

CHANGE IN REPLACEMENT PARTS LIST

SU-X102 (Pages 30~33, 36 of service manual.)

Ref. No.	Part Number		Description	Remarks
	SU-X102 (E)	SU-X120 (E, EB, EG, GN)		
TRANSISTOR(S)				
Q504	—	2SC3311AQSTA	TRANSISTOR	(EB)
Q505	—	2SA1309AQSTA	TRANSISTOR	(EB)
DIODE(S)				
D501, 502	—	MA167TA	DIODE	(EB)
D504	—	MA4051MTA	DIODE	(EB)
TRANSFORMER(S)				
T1	RTP1M5E008-V	RTP1M5B002-V	POWER TRANSFORMER	△ (EB, GN)
FUSE(S)				
F2	XBA2C08TB0	—	FUSE	△ (GN)
CONNECTOR(S)				
J551	—	SJT3213	CONNECTOR (2P)	(EB) Type (B)
JACK(S)				
JK901	SJS9231-1B	SJS9234B	AC INLET	△ (GN)
JK902	SJS9333B	SJS9332B	AC OUTLET	△ (EB)
		—	AC OUTLET	△ (GN)
FUSE HOLDER(S)				
FC 3, 4	SJT388	—	FUSE HOLDER	△ (GN)
RESISTORS				
R515, 516	—	ERDS2TJ223T	RESISTOR ¼ W 22K	(EB)
R517	—	ERDS2TJ563T	RESISTOR ¼ W 56K	(EB)
R520	—	ERDS2TJ153T	RESISTOR ¼ W 15K	(EB)
R521	—	ERDS2TJ103T	RESISTOR ¼ W 10K	(EB)
R522	—	ERDS1FVJ680T	RESISTOR ½ W 68	△ (EB)
R543	—	ERDS1FVJ560T	RESISTOR ½ W 56	△ (EB)
CAPACITORS				
C513	—	ECEA1CKA100B	CAPACITOR 16 V 10 μ	(EB)
C709	ECEA1HKA2R2B	ECEA1HKN2R2B	CAPACITOR 50 V 2.2 μ	
CABINET PARTS				
3	SJP9205-2Y	SJP9205-2T	CABINET	
5	SJS9231A	SJS9234A	AC INLET COVER	(GN)
6	SJS9333A	SJS9332A	AC OUTLET COVER	(EB)
		RJS1A4602	AC OUTLET COVER	(GN)
7	RGR0105K-A1	RGR0105K-C1	REAR PANEL	(E)
		RGR0105T-B	REAR PANEL	(EB) Type (A)
		RGR0105F-D1	REAR PANEL	(EB) Type (B)
		RGR0105K-D1	REAR PANEL	(EG)
		RGR0105M-A1	REAR PANEL	(GN)
19	RGU0591A-K	RGU0591B-K	BUTTON, SUPER BASS	
20	RFKGUX102E	RFKGUX120E-K	FRONT PANEL ASS'Y	
25	—	REM0020-1	FAN MOTOR ASS'Y	(EB) Type (A)
		SYE1128-4	FAN MOTOR ASS'Y	(EB) Type (B)
25-1	—	SHE232-1	FAN	(EB) Type (A)
		SHE232	FAN	(EB) Type (B)
25-2	—	SUS271	SPRING	(EB)
25-3	—	RMQ0209-K	FAN CASE	(EB) Type (A)
		SHE233-1	FAN CASE	(EB) Type (B)
25-4	—	MDN-4RB4MRC	MOTOR	(EB)
25-5	—	RMQ0208-K	CAP	(EB) Type (A)
		SHE234	CAP	(EB) Type (B)
25-6	—	SJT783	TERMINAL	(EB) Type (B)
25-7	—	SJS5215	CONNECTOR (2P)	(EB) Type (B)
25-8	—	RMQ0212-K	TERMINAL CAP	(EB) Type (A)
36	—	RJS1A740Z	CONNECTOR (2P)	(EB) Type (A)
37	—	XTBS3+8JFZ1	SCREW	(EB) Type (A)

Ref. No.	Part Number		Description	Remarks
	SU-X102 (E)	SU-X120 (E, EB, EG, GN)		
PACKING MATERIALS				
P1	RPG0838	RPG1208	PACKING CASE	
P3	SPSD152	—	ACCESSORIES BOX	
ACCESSORIES				
A1	RQF1081	—	INSTRUCTIONS MANUAL ASS'Y	
A1-1	RQA0013	RQX7433ZA	WARRANTY CARD	(GN)
A1-3	RFKSUX102E-K	RFKSCX120E-K	INSTRUCTIONS MANUAL	(E)
		RQT1498-B	INSTRUCTIONS MANUAL	(EB, GN)
		RQT1497-D	INSTRUCTIONS MANUAL	(EG)
A2	SJA187	—	AC POWER SUPPLY CORD	Δ

CONNECTIONS OF EACH UNIT

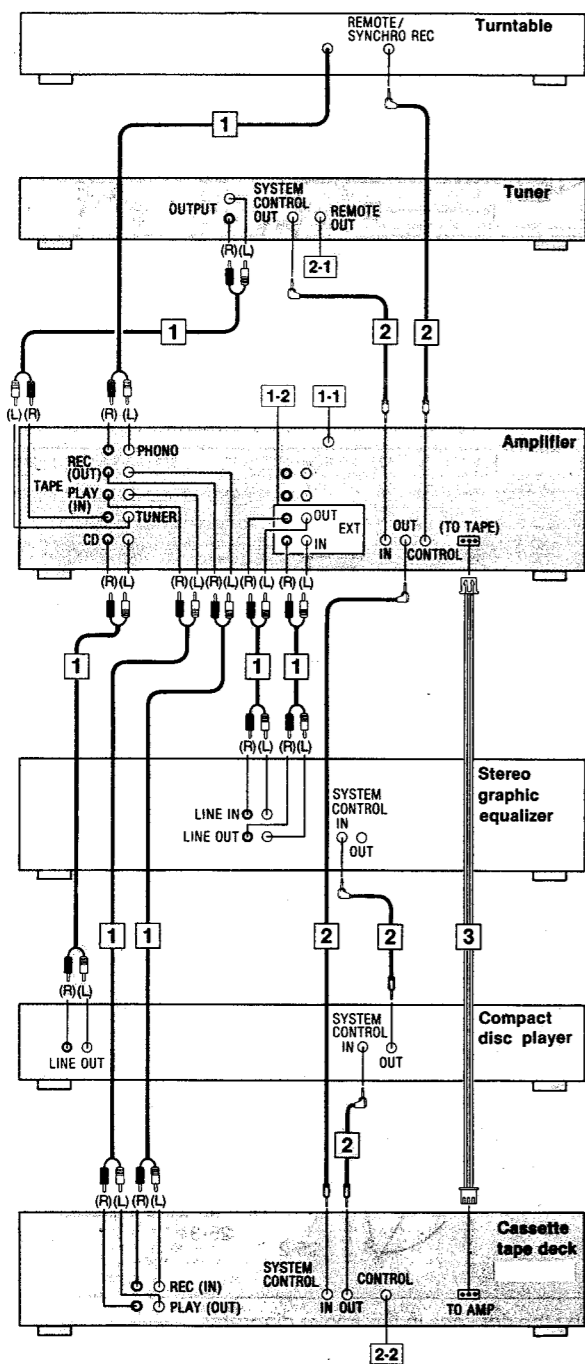

Connection diagrams shown are for connections to a Technics hi-fi component system. Make connections in the numbered sequential order.

- 1 Connect the stereo connection cables** (included with the turntable, tuner, stereo graphic equalizer, and cassette tape deck).

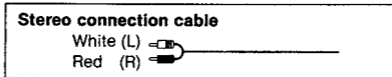

- 1-1 "GND" terminal of the amplifier**
This terminal is for use with a turntable which has a ground wire.

- 1-2 "EXT" terminals of the amplifier**
When these terminals are not in use, be sure to insert the "shorting" pins (included).

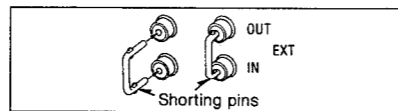

- 2 Connect the L-type cables** (included with the turntable, tuner, stereo graphic equalizer, compact disc player, and cassette tape deck).

- 2-1 "REMOTE OUT" terminal**
This terminal is used to connect to the "REMOTE IN" terminal of the Technics multi-compact disc player (not included).

- 2-2 "CONTROL" terminal**
Make a connection from this terminal to the "CONTROL" terminal for a cassette deck on a Technics multi compact disc player (SL-PK26). (For detailed information, refer to the operating instructions of the Technics multi compact disc player.)

- 3 Connect the 3-core flat cable** (included with the cassette tape deck).

- Connect the AC power supply cords and AC outlet**
(See page 3 of service manual RS-X120, Order No. AD9203066A8.)

SCHEMATIC DIAGRAM

(EB) area only
SU-X102 (Page 18 of service manual.)

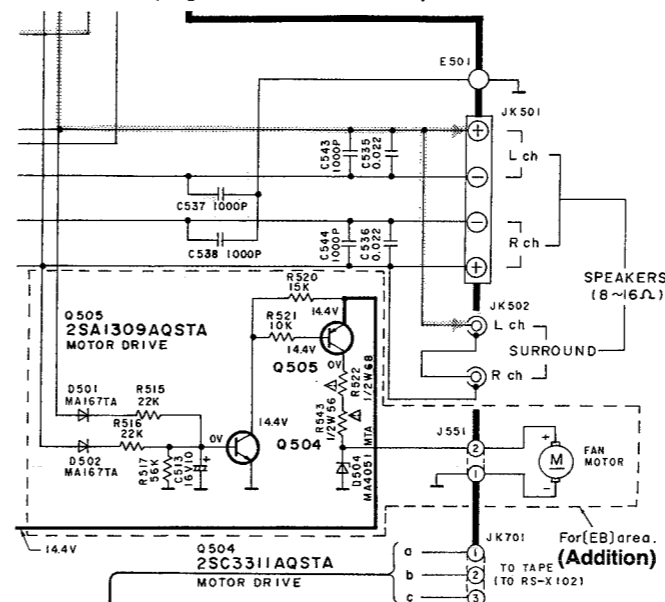

PRINTED CIRCUIT BOARD

(EB) area only
SU-X102 (Page 22 of service manual)

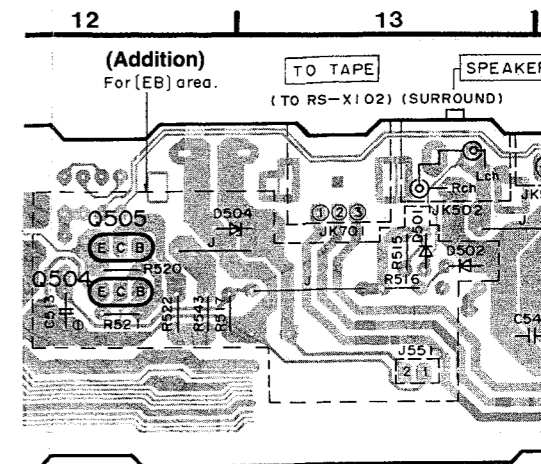

- There are two types of the fan motor, i.e.: **Types A and B.**
Type A... The fan motor terminal is a connector type.
 The "mark (A)" is printed on the main P.C.B. of type A. (Refer to the diagram below.)
Type B... The fan motor terminal is a lead wire type.
 Refer to the diagram below to distinguish type A from type B.

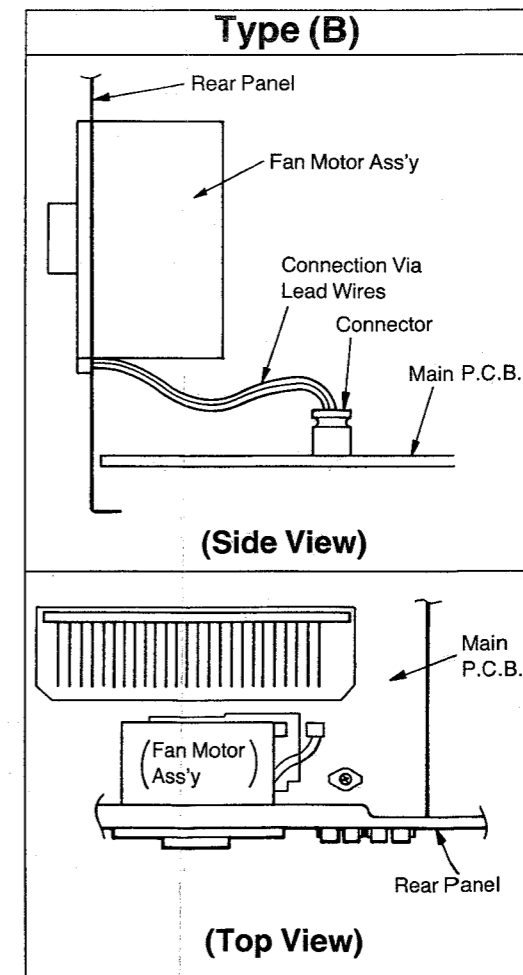
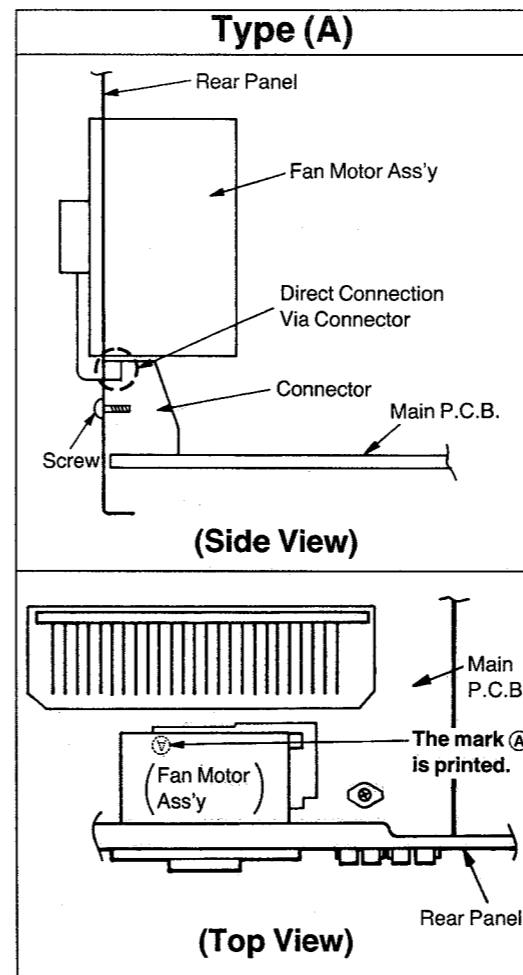

DISASSEMBLY INSTRUCTIONS

(EB) area only

Ref No. 13	Removal of the Fan Motor Ass'y (Type A)
---------------	--

Procedure 1→7→13

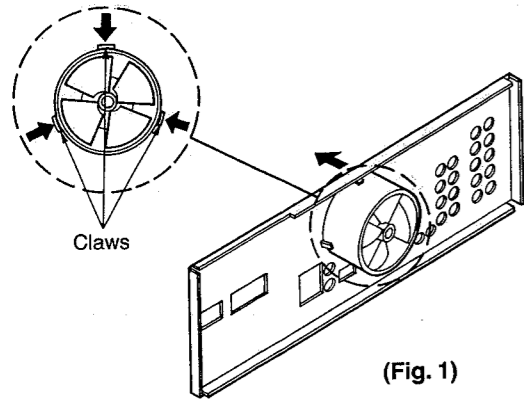

(Fig. 1)

1. Release the 3 claws. (See Fig. 1.)
2. Insert a screwdriver at the root of the fan. Force it out of the motor shaft. (See Fig. 2.)
3. Remove the cap by using ⊖ screwdriver. (See Fig. 3.)
4. Remove the terminal cap in the direction of arrow. (See Fig. 4.)
5. Remove the motor from the fan case. (See Fig. 5.)
6. When mounting the motor, align the fan casing's projection with the hole of the motor. (See Fig. 6.)

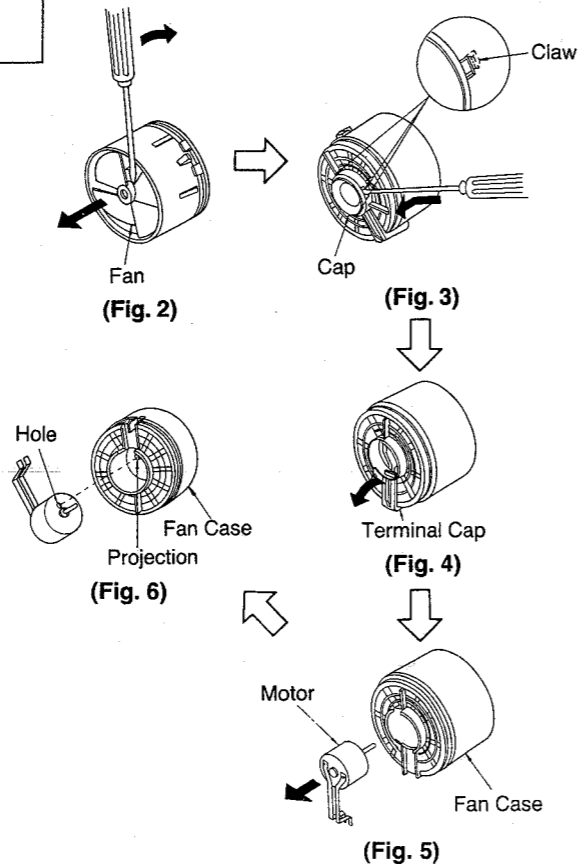

Ref No. 13	Removal of the Fan Motor Ass'y (Type B)
---------------	--

Procedure 1→7→13

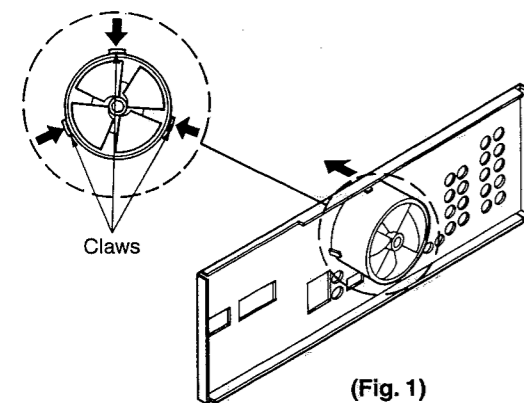

(Fig. 1)

1. Remove the 1 connector (J551).
2. Release the 3 claws. (See Fig. 1.)

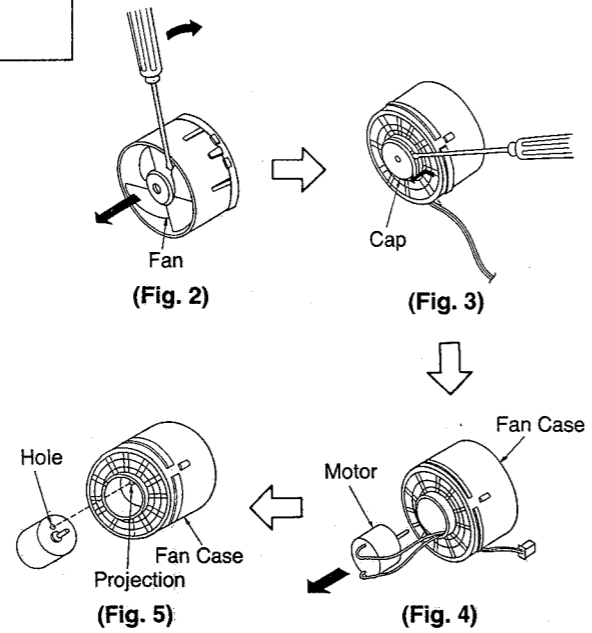

3. Insert a screwdriver at the root of the cooling fan. Force it out of the motor shaft. (See Fig. 2.)
4. Remove the cap by using ⊖ screwdriver. (See Fig. 3.)
5. Remove the motor from the fan casing. (See Fig. 4.)
6. When mounting the motor fan, align the fan casing's projection with the hole of the motor. (See Fig. 5.)

CABINET PARTS LOCATION (EB) area only

(Type A)

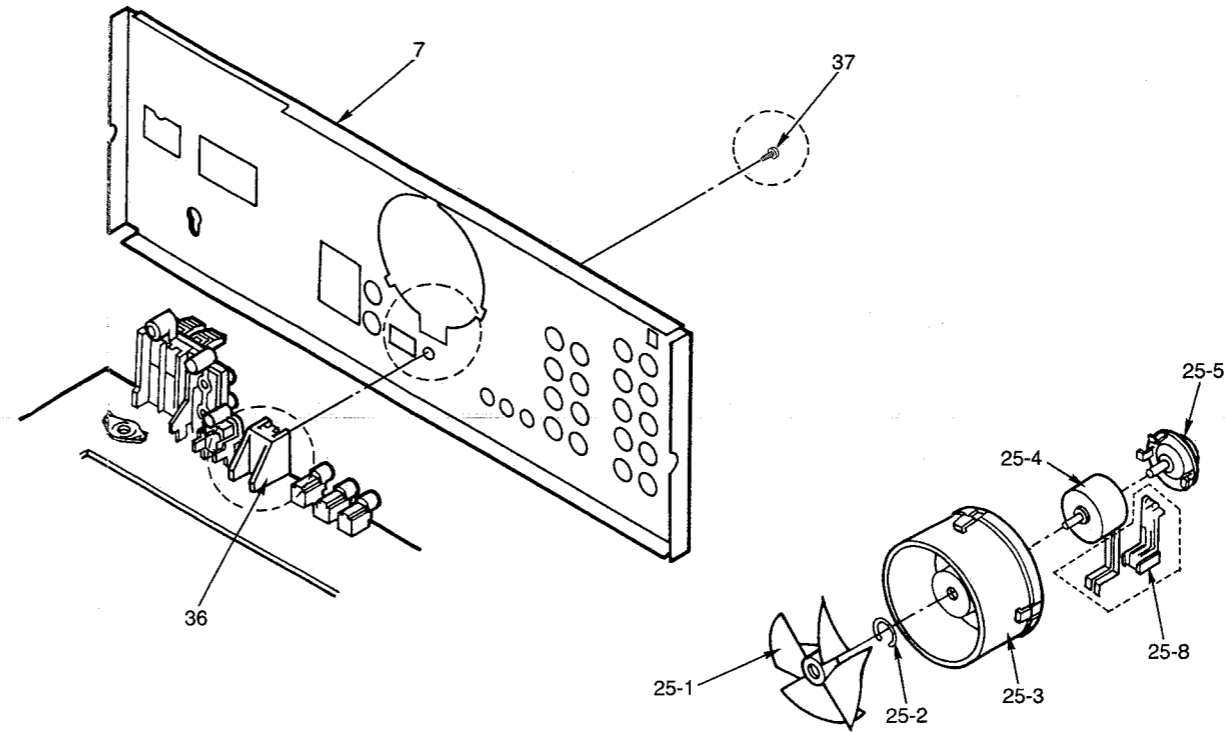

(Type B)

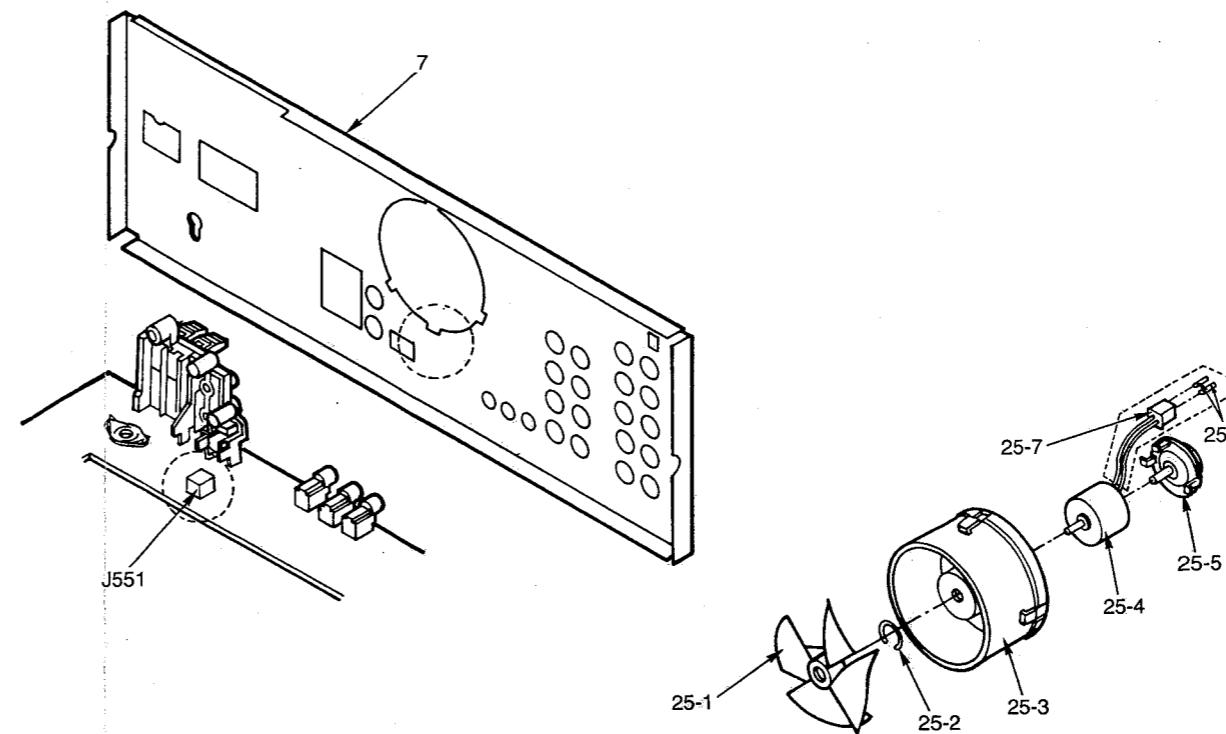

Note: The different parts between type A and type B are enclosed by the dot lines in the above diagrams.

Ref. No.	Part Number		Description	Remarks
	SU-X102 (E)	SU-X120 (E, EB, EG, GN)		
PACKING MATERIALS				
P1	RPG0838	RPG1208	PACKING CASE	
P3	SPSD152	—	ACCESSORIES BOX	
ACCESSORIES				
A1	RQF1081	—	INSTRUCTIONS MANUAL ASS'Y	
A1-1	RQA0013	RQX7433ZA	WARRANTY CARD	(GN)
A1-3	RFKSUX102E-K	RFKSCX120E-K	INSTRUCTIONS MANUAL	(E)
		RQT1498-B	INSTRUCTIONS MANUAL	(EB, GN)
		RQT1497-D	INSTRUCTIONS MANUAL	(EG)
A2	SJA187	—	AC POWER SUPPLY CORD	Δ

CONNECTIONS OF EACH UNIT

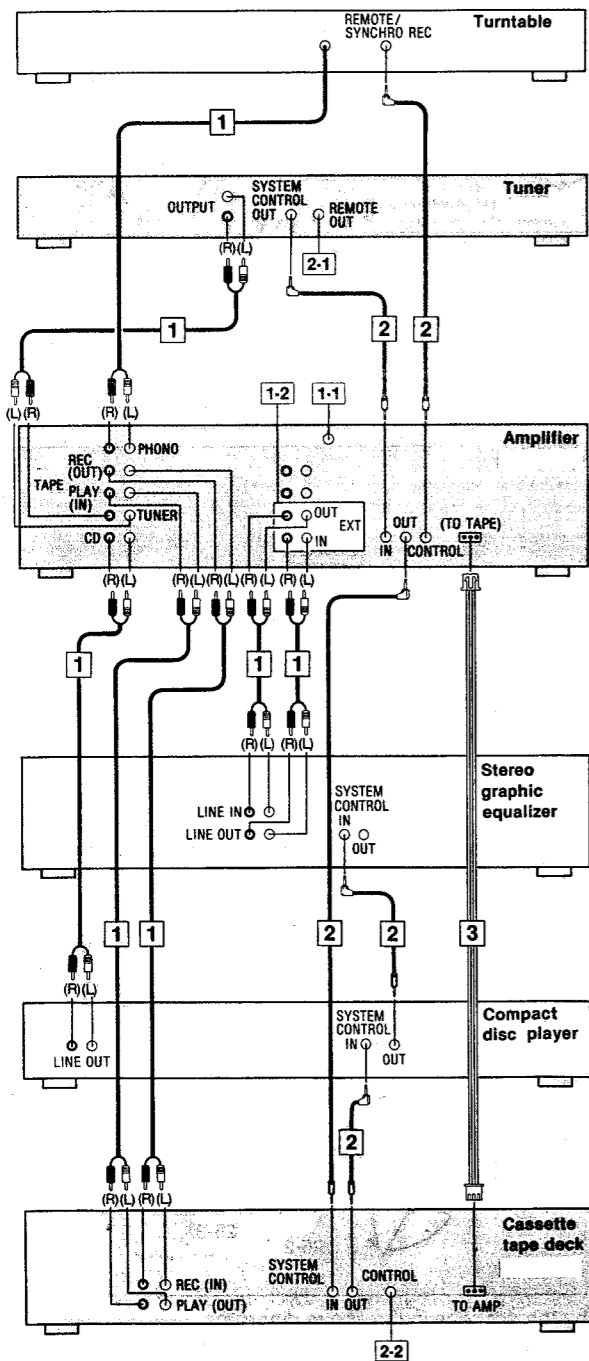

Connection diagrams shown are for connections to a Technics hi-fi component system. Make connections in the numbered sequential order.

- 1 Connect the stereo connection cables** (included with the turntable, tuner, stereo graphic equalizer, and cassette tape deck).

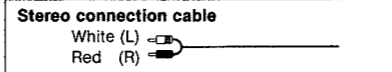

- 1-1 "GND" terminal of the amplifier**
This terminal is for use with a turntable which has a ground wire.

- 1-2 "EXT" terminals of the amplifier**
When these terminals are not in use, be sure to insert the "shorting" pins (included).

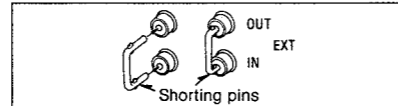

- 2 Connect the L-type cables** (included with the turntable, tuner, stereo graphic equalizer, compact disc player, and cassette tape deck).

- 2-1 "REMOTE OUT" terminal**
This terminal is used to connect to the "REMOTE IN" terminal of the Technics multi-compact disc player (not included).

- 2-2 "CONTROL" terminal**
Make a connection from this terminal to the "CONTROL" terminal for a cassette deck on a Technics multi compact disc player (SL-PK26). (For detailed information, refer to the operating instructions of the Technics multi compact disc player.)

- 3 Connect the 3-core flat cable** (included with the cassette tape deck).

- Connect the AC power supply cords and AC outlet**
(See page 3 of service manual RS-X120, Order No. AD9203066A8.)

SCHEMATIC DIAGRAM

(EB) area only
SU-X102 (Page 18 of service manual.)

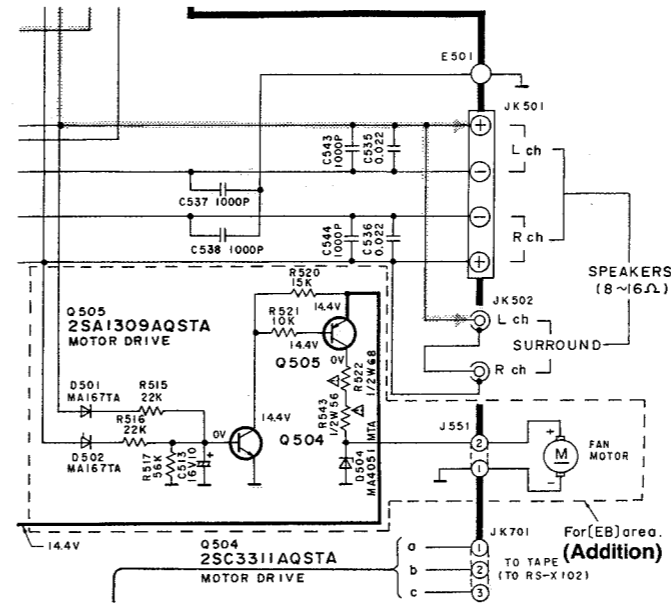

DISASSEMBLY INSTRUCTIONS

(EB) area only

Ref No. 13	Removal of the Fan Motor Ass'y (Type A)	
Procedure 1→7→13		

1. Release the 3 claws. (See Fig. 1.)
2. Insert a screwdriver at the root of the fan. Force it out of the motor shaft. (See Fig. 2.)
3. Remove the cap by using ⊖ screwdriver. (See Fig. 3.)
4. Remove the terminal cap in the direction of arrow. (See Fig. 4.)
5. Remove the motor from the fan case. (See Fig. 5.)
6. When mounting the motor, align the fan casing's projection with the hole of the motor. (See Fig. 6.)

Ref No. 13	Removal of the Fan Motor Ass'y (Type B)	
Procedure 1→7→13		

1. Remove the 1 connector (J551).
2. Release the 3 claws. (See Fig. 1.)
3. Insert a screwdriver at the root of the cooling fan. Force it out of the motor shaft. (See Fig. 2.)
4. Remove the cap by using ⊖ screwdriver. (See Fig. 3.)
5. Remove the motor from the fan casing. (See Fig. 4.)
6. When mounting the motor fan, align the fan casing's projection with the hole of the motor. (See Fig. 5.)

CABINET PARTS LOCATION (EB) area only

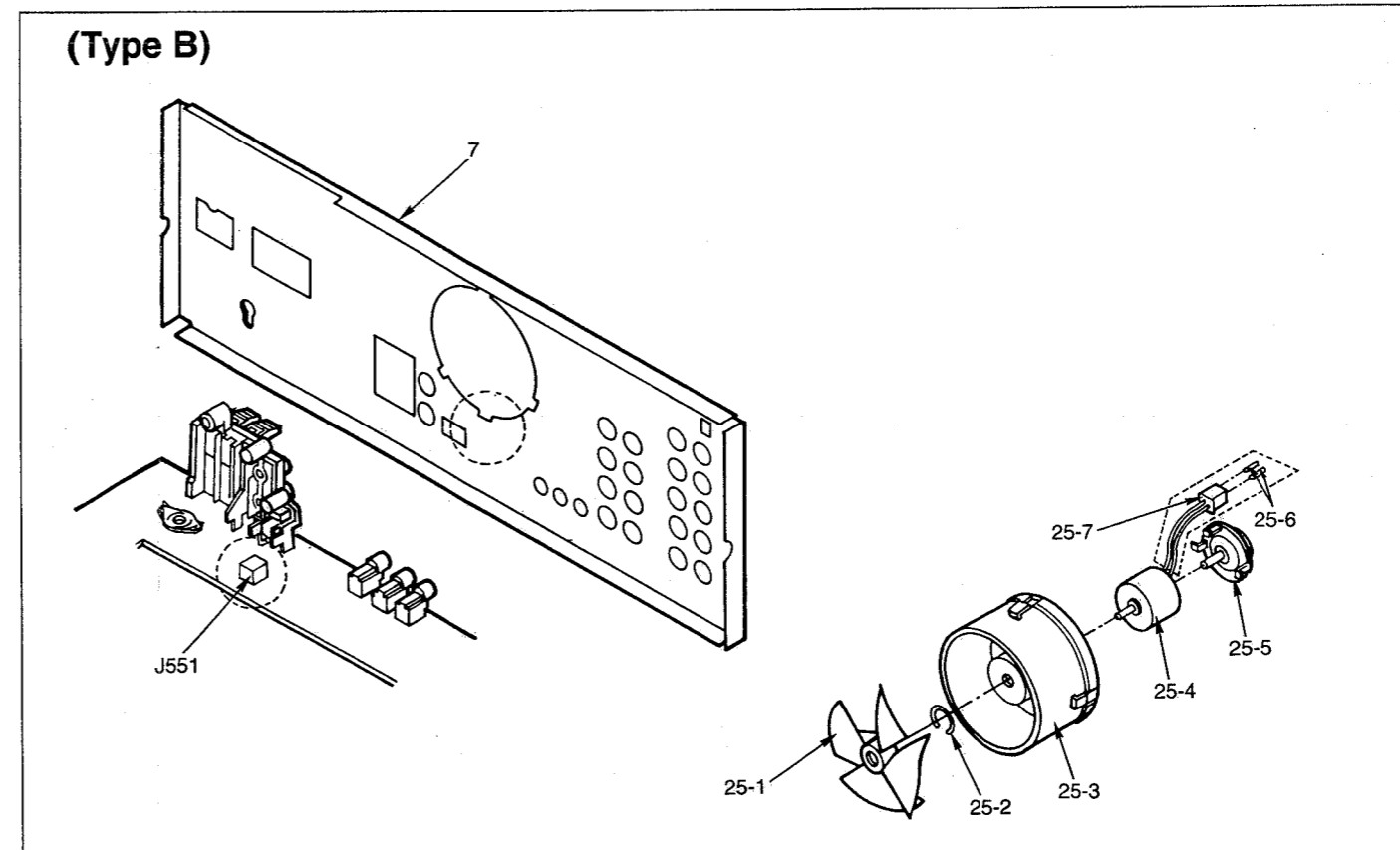
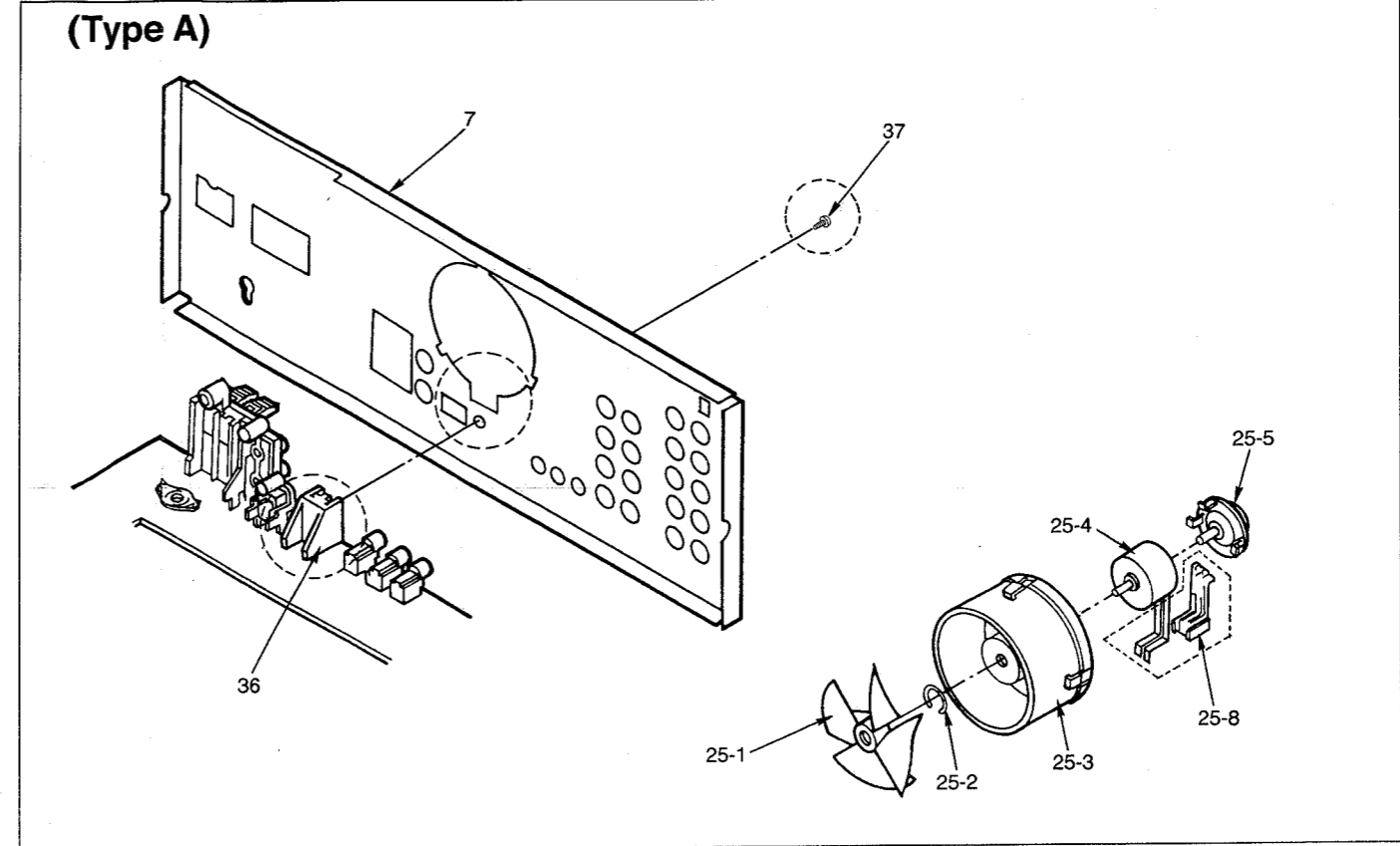

Note: The different parts between type A and type B are enclosed by the dot lines in the above diagrams.