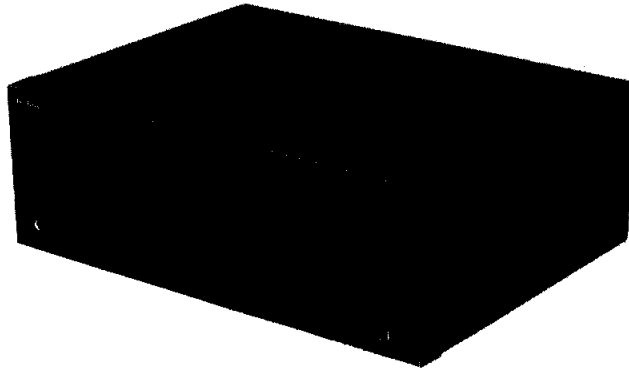

Service Manual

Amplifier

SU-X320

Stereo Integrated Amplifier

Simplified

Colour

(K) Black Type

Areas

Suffix for Model No.	Area	Colour
(E)	Europe	(K)
(EB)	Great Britain	
(EG)	Germany and Italy	
(GN)	Oceania	

- Please file and use this manual together with the Service Manual for Model No. SU-X302, Order No. AD9103050C8.
- This service manual indicates the main differences between Original SU-X302 (E).

■ LINE-UP OF COMPONENTS

System Name	Unit
SC-X320 (E)	ST-X302LA (E) : Tuner
	SU-X320 (E) : Amplifier
	RS-X320 (EG) : Cassette Deck
	— : CD Player
	SL-J110R (E) : Turntable
	SB-CS65 (E) : Speaker (Made in PAES)
SC-X320 (EB)	ST-X302LA (EB) : Tuner
	SU-X320 (EB) : Amplifier
	RS-X320 (EG) : Cassette Deck
	SL-PJ28A (EB) : CD Player (Made in MBV)
	SL-J110R (EB) : Turntable
	SB-CS65 (E) : Speaker (Made in PAES)
SC-X320 (EF)	ST-X302LA (EF) : Tuner (Made in PFS)
	SU-X320 (E) : Amplifier
	RS-X320 (EG) : Cassette Deck
	SL-PJ28A (E) : CD Player (Made in MBV)
	SL-J110R (E) : Turntable
	SB-CS65 (E) : Speaker (Made in PAES)

System Name	Unit
SC-X320 (EG)	ST-X302LA (EG) : Tuner
	SU-X320 (EG) : Amplifier
	RS-X320 (EG) : Cassette Deck
	SL-PJ28A (EG) : CD Player (Made in MBV)
	SL-J110R (EG) : Turntable
	SB-CS65 (E) : Speaker (Made in PAES)
SC-X320 (EI)	ST-X302LA (EI) : Tuner (Made in PFS)
	SU-X320 (EG) : Amplifier
	RS-X320 (EG) : Cassette Deck
	SL-PJ28A (EG) : CD Player (Made in MBV)
	SL-J110R (EG) : Turntable
	SB-CS65 (E) : Speaker (Made in PAES)
SC-X320 (GN)	ST-X302LA (GN) : Tuner
	SU-X320 (GN) : Amplifier
	RS-X320 (GC) : Cassette Deck
	SL-PJ28 (GN) : CD Player
	SL-J110R (GN) : Turntable
	SB-CD320 (GC) : Speaker

Technics

CHANGES

■ CHANGE IN REPLACEMENT PARTS LIST

SU-X302 (Page 30~33, 36 of service manual.)

Ref. No.	Part Number		Description	Remarks
	SU-X302 (E)	SU-X320 (E, EB, EG, GN)		
TRANSFORMER(S)				
T1	RTP1M5E007-V	RTP1M5B001-V	POWER TRANSFORMER	△ (EB, GN)
FUSE(S)				
F2	XBA2C10TB0	—	FUSE	△ (GN)
FUSE HOLDER(S)				
FC3, 4	SJT388	—	FUSE HOLDER	△ (GN)
JACK(S)				
JK901	SJS9231-1B	SJS9234B	AC INLET	△ (GN)
JK902	SJS9333B	SJS9332B	AC OUTLET	△ (EB)
		—	AC OUTLET	△ (GN)
CAPACITORS				
C709	ECEA1HKA2R2B	ECEA1HKN2R2B	CAPACITOR 50 V 2.2 μ	
CABINET PARTS				
3	SJP9205-2Y	SJP9205-2T	SHORTING PIN	
5	SJS9231A	SJS9234A	AC INLET COVER	(GN)
6	SJS9333A	SJS9332A	AC OUTLET COVER	(EB)
		RJS1A4602	AC OUTLET COVER	(GN)
7	RGR0105G-A1	RGR0105V-A	REAR PANEL	(E) Type (A)
		RGR0105G-C1	REAR PANEL	(E) Type (B)
		RGR0105T-A	REAR PANEL	(EB) Type (A)
		RGR0105F-C1	REAR PANEL	(EB) Type (B)
		RGR0105V-B	REAR PANEL	(EG) Type (A)
		RGR0105G-D1	REAR PANEL	(EG) Type (B)
		RGR0105W-A	REAR PANEL	(GN) Type (A)
		RGR0105J-A1	REAR PANEL	(GN) Type (B)
19	RGU0591A-K	RGU0591B-K	BUTTON, SUPER BASS	
20	RFKGUX302E	RFKGUX320E-K	FRONT PANEL ASS'Y	
25	SYE1128-2	REM0020-1	FAN MOTOR ASS'Y	Type (A)
		SYE1128-4	FAN MOTOR ASS'Y	Type (B)
25-1	—	SHE232-1	FAN	Type (A)
25-3	SHE233	RMQ0209-K	FAN CASE	Type (A)
		SHE233-1	FAN CASE	Type (B)
25-5	—	RMQ0208-K	CAP	Type (A)
25-6	—	SJT783	TERMINAL	Type (B)
25-7	—	SJS5215	CONNECTOR (2P)	Type (B)
25-8	—	RMQ0212-K	TERMINAL CAP	Type (A)
36	—	RJS1A7402	CONNECTOR (2P)	Type (A)
37	—	XTBS3+8JFZ1	SCREW	Type (A)
PACKING MATERIALS				
P1	RPG0839	RPG1207	PACKING CASE	
P3	SPSD152	—	ACCESSORIES BOX	
ACCESSORIES				
A1	RQF1086	—	INSTRUCTIONS MANUAL ASS'Y	
A1-1	RQA0013	RQX7433ZA	WARRANTY CARD	(GN)
A1-3	RFKSUX302E-K	RFKSCX120E-K	INSTRUCTIONS MANUAL	(E)
		RQT1498-B	INSTRUCTIONS MANUAL	(EB, GN)
		RQT1497-D	INSTRUCTIONS MANUAL	(EG)
A2	SJA187	—	AC POWER SUPPLY CORD	△

CONNECTIONS OF EACH UNIT

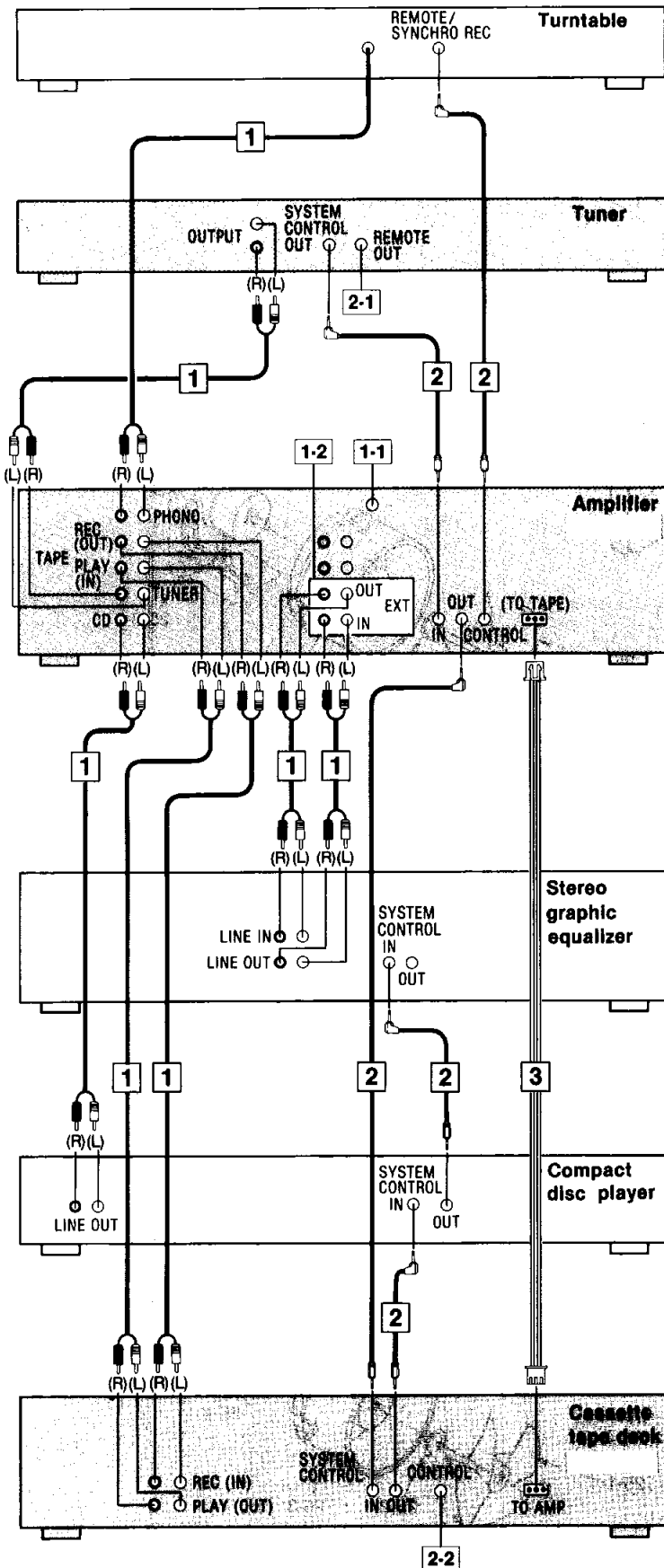

Connection diagrams shown are for connections to a Technics hi-fi component system. Make connections in the numbered sequential order.

- 1 Connect the stereo connection cables** (included with the turntable, tuner, stereo graphic equalizer, and cassette tape deck).

Stereo connection cable

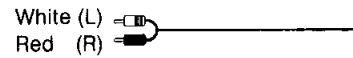

1-1

"GND" terminal of the amplifier

This terminal is for use with a turntable which has a ground wire.

1-2

"EXT" terminals of the amplifier

When these terminals are not in use, be sure to insert the "shorting" pins (included).

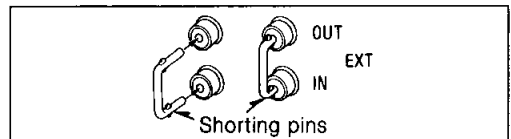

- 2 Connect the L-type cables** (included with the turntable, tuner, stereo graphic equalizer, compact disc player, and cassette tape deck).

2-1

"REMOTE OUT" terminal

This terminal is used to connect to the "REMOTE IN" terminal of the Technics multi-compact disc player (not included).

2-2

"CONTROL" terminal

Make a connection from this terminal to the "CONTROL" terminal for a cassette deck on a Technics multi compact disc player (SL-PK26). (For detailed information, refer to the operating instructions of the Technics multi compact disc player.)

- 3 Connect the 3-core flat cable** (included with the cassette tape deck).

Connect the AC power supply cords and AC outlet

(See page 3 of service manual RS-X320, Order No. AD9203067A8.)

• There are two types of the fan motor, i.e: Types A and B.

Type A...The fan motor terminal is a connector type.

The "mark (A)" is printed on the main P.C.B. of type A. (Refer to the diagram below.)

Type B...The fan motor terminal is a lead wire type.

Refer to the diagram below to distinguish type A from type B.

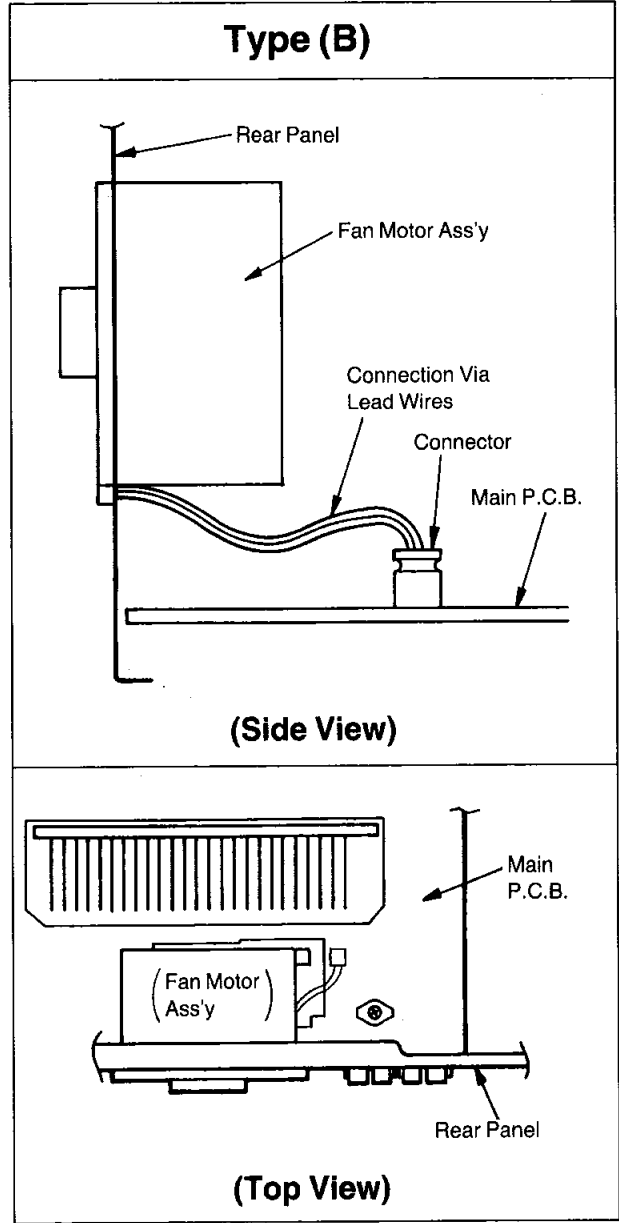
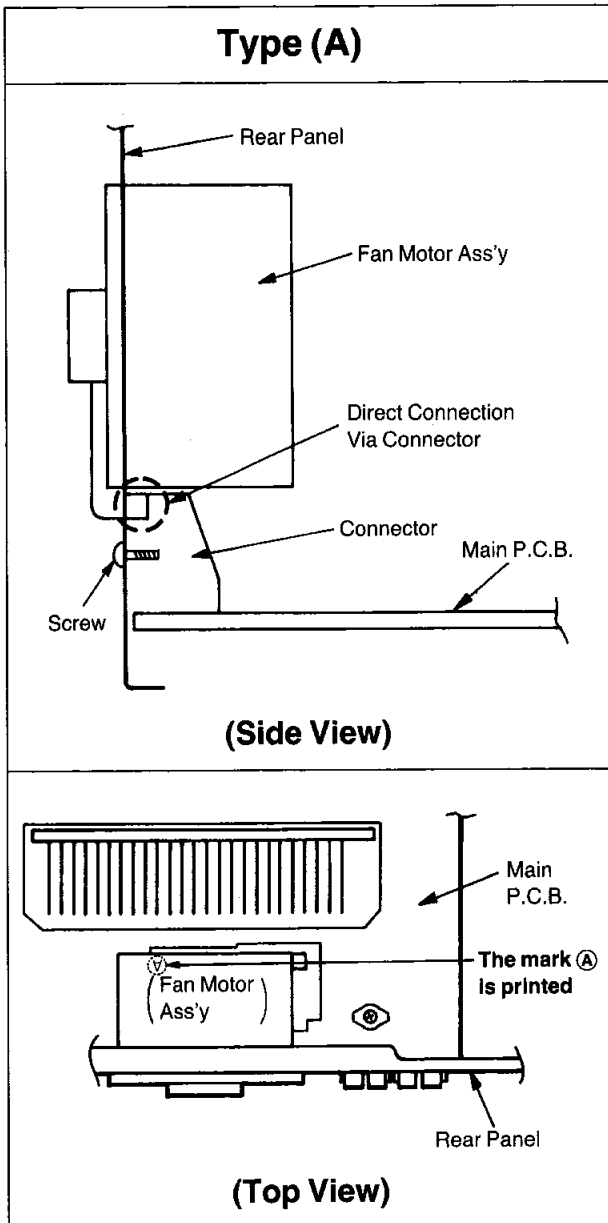

DISASSEMBLY INSTRUCTIONS

Ref. No.
13 **Removal of the Fan Motor Ass'y**
(Type A)

Procedure
1→7→13

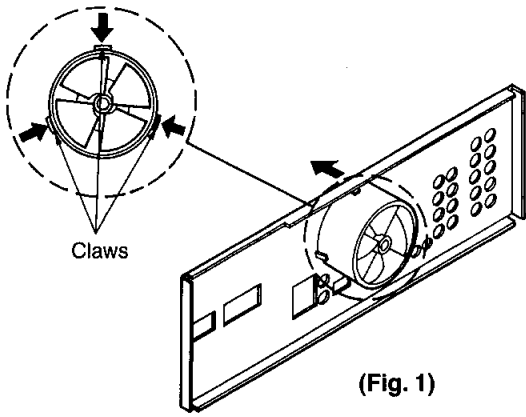

(Fig. 1)

1. Release the 3 claws. (See Fig. 1.)
2. Insert a screwdriver at the root of the fan. Force it out of the motor shaft. (See Fig. 2.)
3. Remove the cap by using ⊖ screwdriver. (See Fig. 3.)
4. Remove the terminal cap in the direction of arrow. (See Fig. 4.)
5. Remove the motor from the fan case. (See Fig. 5.)
6. When mounting the motor, align the fan casing's projection with the hole of the motor. (See Fig. 6.)

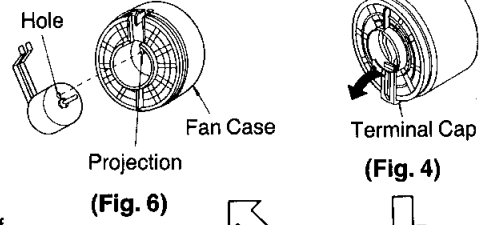
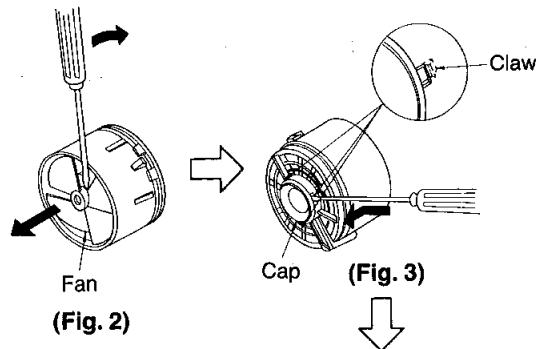

(Fig. 5)

Ref. No.
13 **Removal of the Fan Motor Ass'y**
(Type B)

Procedure
1→7→13

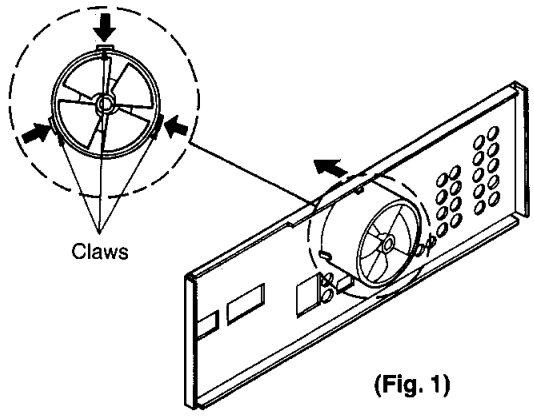

(Fig. 1)

1. Remove the 1 connector (J551).
2. Release the 3 claws. (See Fig. 1.)

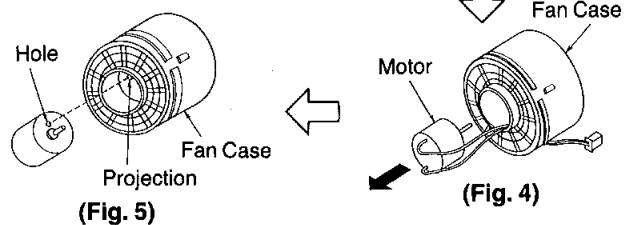
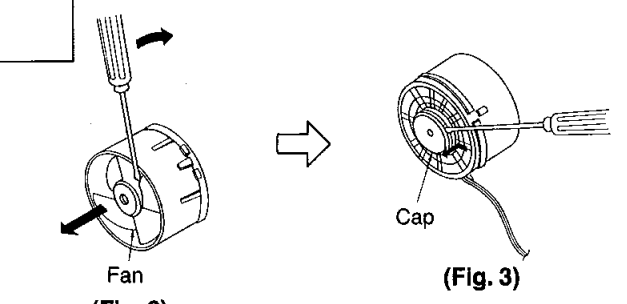

(Fig. 4)

3. Insert a screwdriver at the root of the cooling fan. Force it out of the motor shaft. (See Fig. 2.)
4. Remove the cap by using ⊖ screwdriver. (See Fig. 3.)
5. Remove the motor from the fan casing. (See Fig. 4.)
6. When mounting the motor fan, align the fan casing's projection with the hole of the motor. (See Fig. 5.)

■ CABINET PARTS LOCATION

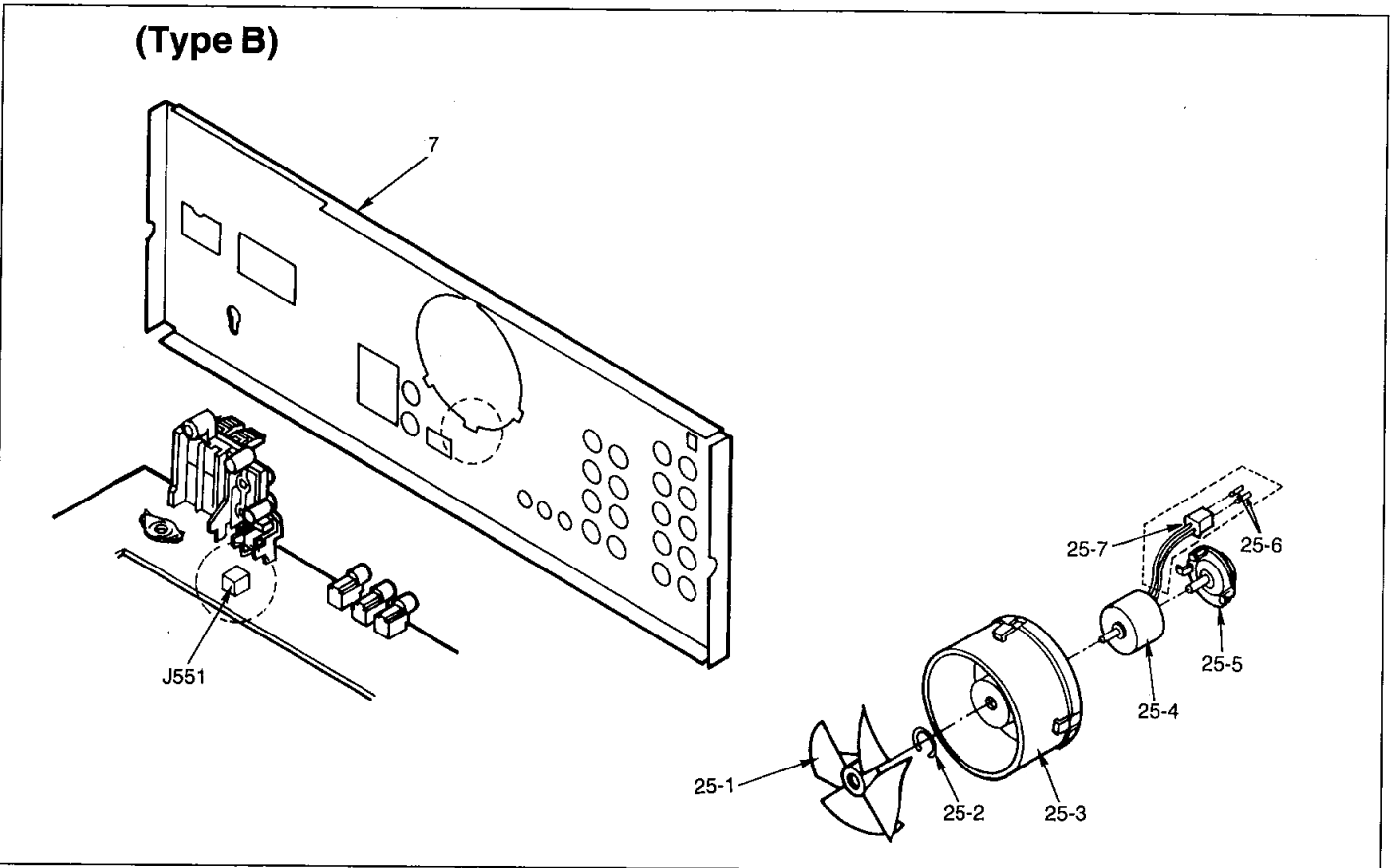
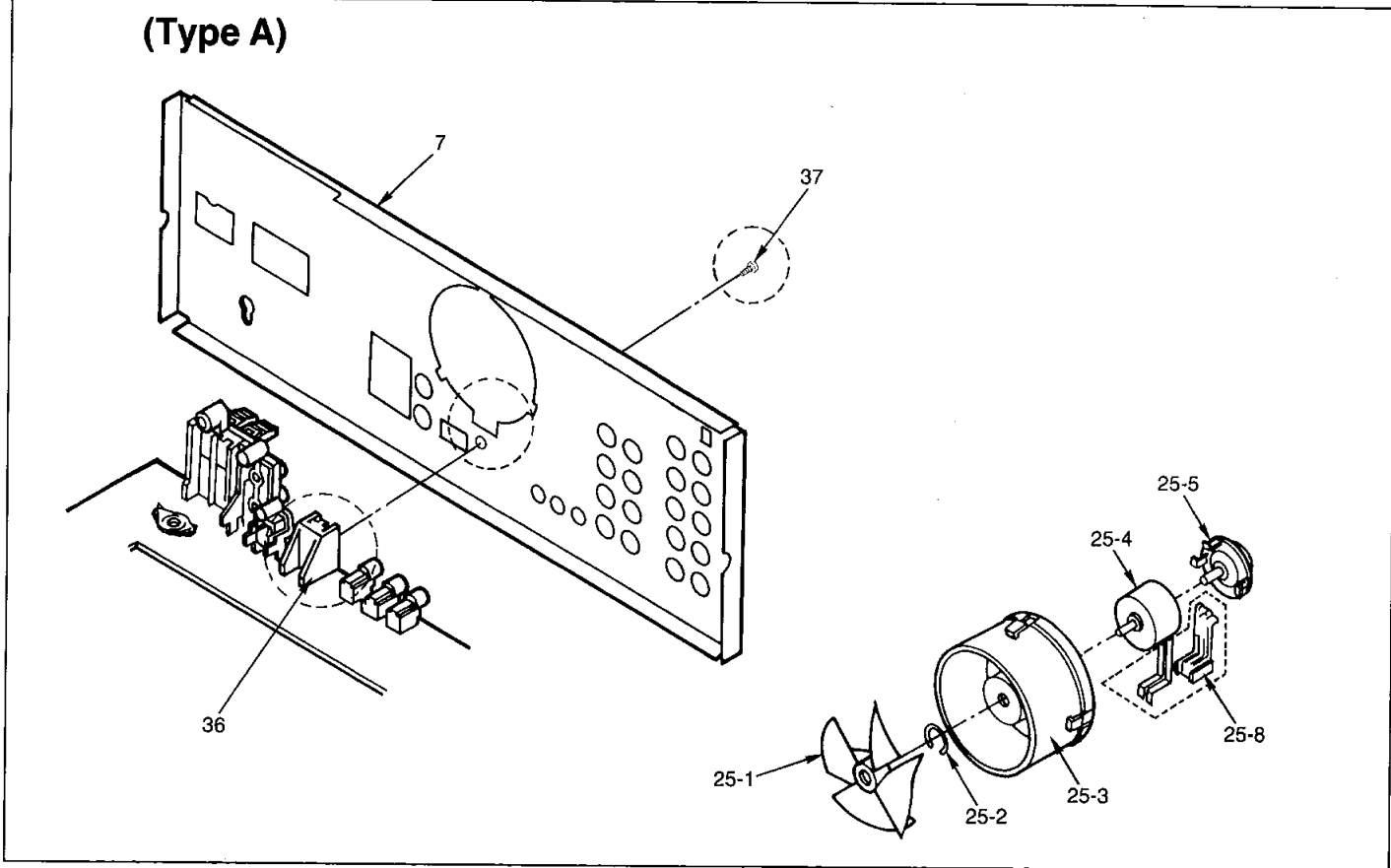

Note: The different parts between type A and type B are enclosed by the dot lines in the above diagrams.