

Service Manual

Digital Integrated Amplifier

Amplifier
SU-X901

Color

(K) Black Type



Area

Country Code	Area	Color
(E)	Continental Europe	(K)
(EB)	Great Britain	(K)
(EG)	F.R. Germany & Italy	(K)

SPECIFICATIONS

(DIN 45 500)

■ AMPLIFIER SECTION

DIN power output	
1 kHz THD: 1 %	2 × 100 W (8 Ω)
Total harmonic distortion	
rated power at 1 kHz	1 % (8 Ω)
Harmonic distortion	
half power at 1 kHz	0.007 % (8 Ω)
Residual hum and noise	0.2 mV
Damping factor	30 (8 Ω)
Input sensitivity and impedance	
PHONO	3 mV/47 kΩ
TUNER, AUX, TAPE 1, TAPE 2	150 mV/22 kΩ
CD	200 mV/22 kΩ
Maximum input voltage (1 kHz, RMS)	
PHONO	100 mV
S/N (rated power 8 Ω)	
PHONO	75 dB (IHF, A: 79 dB)
TUNER, CD, AUX, TAPE 1, TAPE 2	82 dB (IHF, A: 83 dB)
Frequency response	
PHONO	RIAA standard curve ±0.8 dB (30 Hz~15 kHz)
TUNER, CD, AUX, TAPE 1, TAPE 2	15 Hz~60 kHz (-3 dB)
CD, DAT, AUX (digital section)	15 Hz~20 kHz (-0.5 dB)
Tone controls	
BASS	50 Hz, +10 dB~-10 dB
TREBLE	20 kHz, +10 dB~-10 dB
Muting	-20 dB
Super bass	70 Hz, +10 dB

Output voltage

TAPE 1, TAPE 2, REC OUT	150 mV
Channel balance, AUX 250 Hz~6,300 Hz	±1.0 dB
Channel separation, (TUNER, 1 kHz) (A SPEAKER)	60 dB
Headphones output level and impedance	660 mV/330 Ω
Load impedance	
A or B, A and B	8 Ω~16 Ω
SURROUND	8 Ω~16 Ω

■ GENERAL

Power consumption	460 W
Power supply	
For Great Britain	AC 50 Hz/60 Hz, 240 V
For others	AC 50 Hz/60 Hz, 220 V
Dimensions (W × H × D)	360 × 128 × 300 mm (14-3/16" × 5-1/32" × 11-13/16")
Weight	7.9 kg (17.4 lb.)

Notes:

- Specifications are subject to change without notice.
- Weight and dimensions are approximate.
- Total harmonic distortion is measured by the digital spectrum analyzer.

Technics

Matsushita Electric Industrial Co., Ltd.
Central P.O. Box 288, Osaka 530-91, Japan

■ CONTENTS

	Page		Page
BEFORE REPAIR	2	PRINTED CIRCUIT BOARDS	23~26
PROTECTION CIRCUITRY	2	TERMINAL GUIDE OF IC'S, TRANSISTORS AND DIODES	27
ACCESSORY	2	WIRING CONNECTION DIAGRAM	27, 28
LOCATION OF CONTROLS	3	BLOCK DIAGRAM	28~30
CONNECTIONS	4~6	DESCRIPTION OF FL PANEL	31
DIGITALIZATION OF AUDIO SIGNALS	7	FUNCTIONS OF IC TERMINALS	31, 32
DISASSEMBLY INSTRUCTIONS	8~11	REPLACEMENT PARTS LIST	33~36, 39~41
MEASUREMENTS AND ADJUSTMENTS	12	EXPLODED VIEW	37, 38
SCHEMATIC DIAGRAM	13~22		

■ BEFORE REPAIR

- (1) Turn off the power supply. Using a 10 Ω , 5W resistor connect both ends of power supply capacitors (C711, C712, 6800 μ F) in order to discharge the voltage.
- (2) Before turning the power supply on, after completion of repair, slowly apply the primary voltage by using a power supply voltage controller to make sure that the consumed current at 50Hz/60Hz in NO SIGNAL mode should be shown below with respect to supply voltage 220V/240V.

Power supply voltage	AC220V	AC240V
Consumed current 50Hz	200~500 mA	180~450 mA
Consumed current 60Hz	200~500 mA	180~450 mA

■ PROTECTION CIRCUITRY

The protection circuitry may have operated if either of the following conditions is noticed:

- * No sound is heard when the power is switched ON.
- * Sound stops during a performance.

The function of this circuitry is to prevent circuitry damage if, for example, the positive and negative speaker connection wires are "shorted", or if speaker systems with an impedance less than the indicated rated impedance of this unit are used.

If this occurs, follow the procedure outlined below:

1. Switch OFF the power.
2. Determine the cause of the problem and correct it.
3. Switch ON the power once again.

Note:

When the protection circuitry functions, the unit will not operate unless the power is first switched OFF and then ON again.

■ ACCESSORY

- AC power supply cord1
Configuration of AC power supply cord differs according to area.

SJA188 For (EB) area only.
SFDAC05E03 For others.

LOCATION OF CONTROLS

Front panel

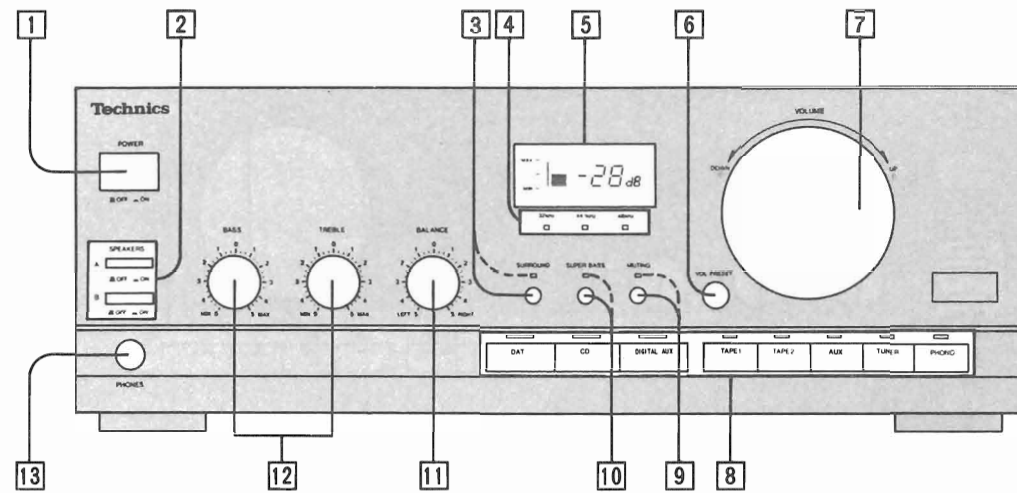

- 1 Power switch (POWER)
- 2 Speaker selector (SPEAKERS)
- 3 Surround-sound switch/indicator (SURROUND)
- 4 Sampling frequency indicators
32 kHz: For digital signals with the 32 kHz mode sampling frequency
44.1 kHz: CD and others
48 kHz: For digital signals with the 48 kHz mode sampling frequency
- 5 Volume-level indicator
- 6 Volume preset button (VOL PRESET)
- 7 Volume control (VOLUME)
- 8 Input selectors/indicators
- 9 Audio muting switch/indicator (MUTING)
- 10 Super bass switch/indicator (SUPER BASS)
- 11 Balance control (BALANCE)
- 12 Tone controls (BASS/TREBLE)
- 13 Headphones jack (PHONES)

Rear panel

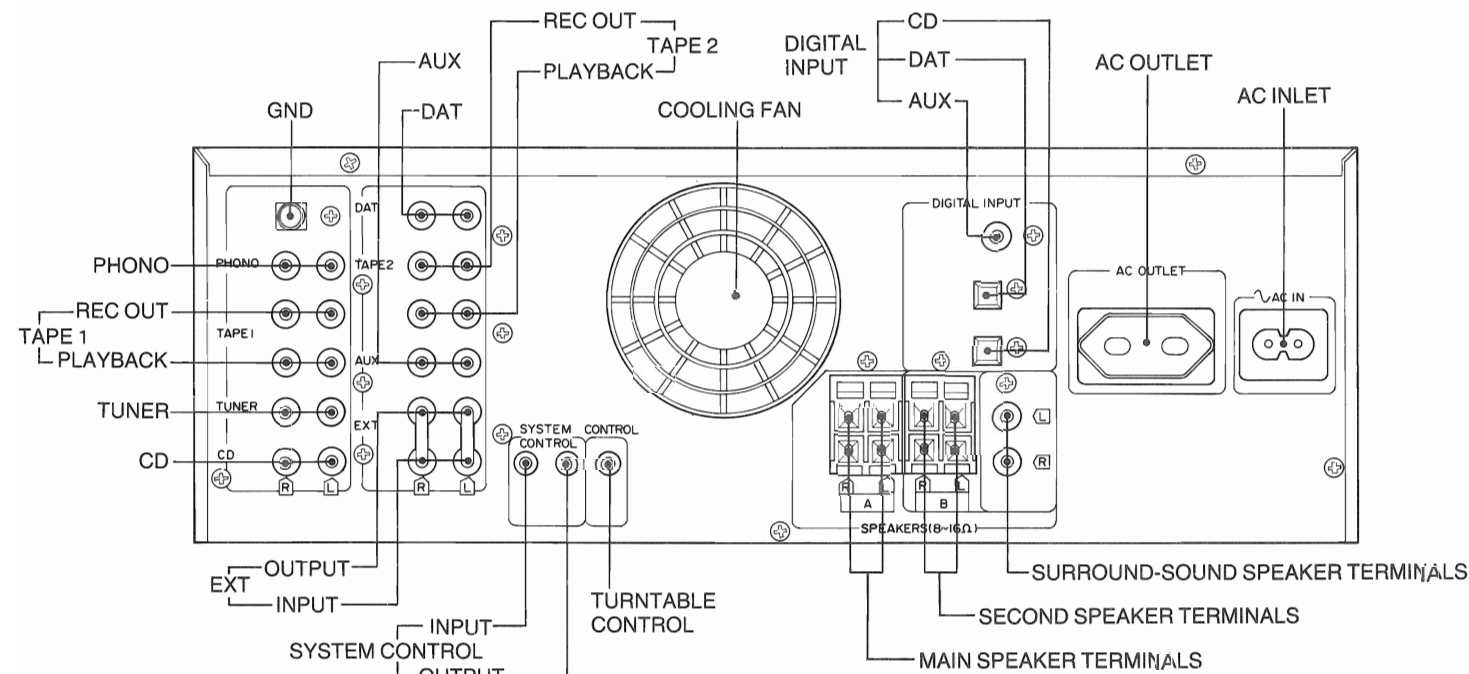

*Phono input capacitance is about 270 pF for EG area (about 100 pF for other areas).

CONNECTIONS

Make connections to each component in the system by using stereo connection cables (not included).

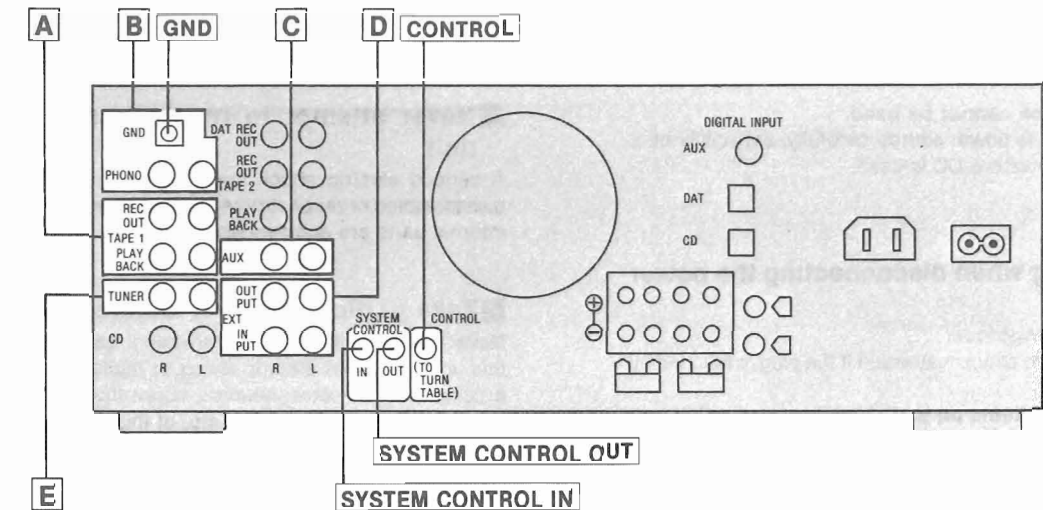

A "TAPE 1" terminals

Connect a first tape deck.

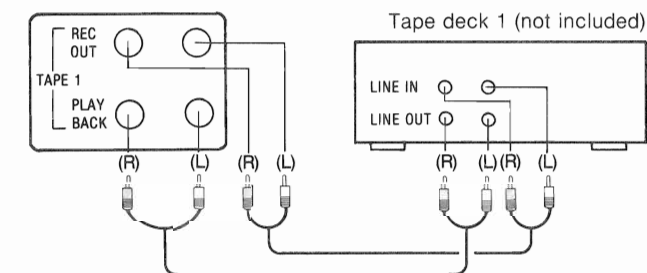

"SYSTEM CONTROL OUT" terminal

This terminal is used to connect a Technics tape deck with the control terminal.

B "PHONO" terminals

Connect a turntable.

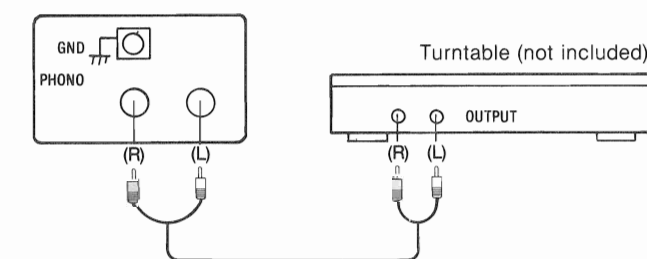

"GND" terminal

This terminal is for use with a turntable which has a ground wire.

"CONTROL" terminal

This terminal is used to connect a Technics turntable with the remote-control terminal.

C "AUX" terminals

Connect a video disc player (Only the audio is connectable), etc.

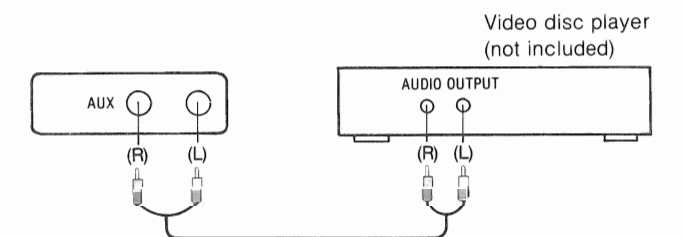

D "EXT" terminals

Connect a graphic equalizer.

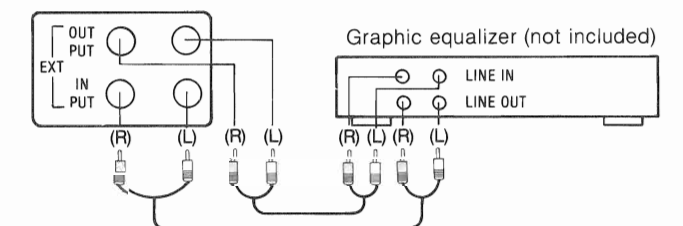

Note:

When these terminals are not in use, be sure to insert the "shorting" pins (included).

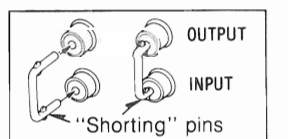

E "TUNER" terminals

Connect a tuner.

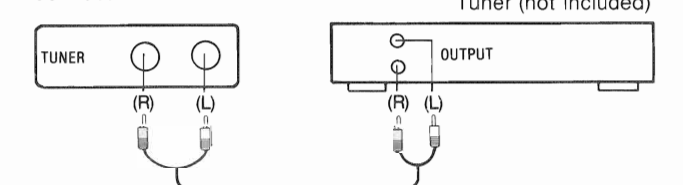

"SYSTEM CONTROL IN" terminal

This terminal is used to connect a Technics tuner with the control terminal.

CONNECTIONS

Make connections to each component in the system by using stereo connection cables (not included).

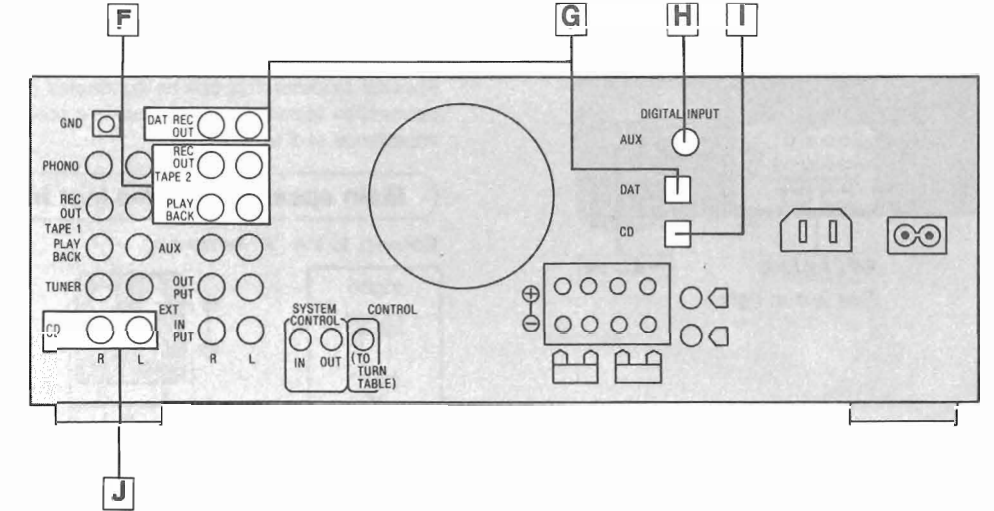
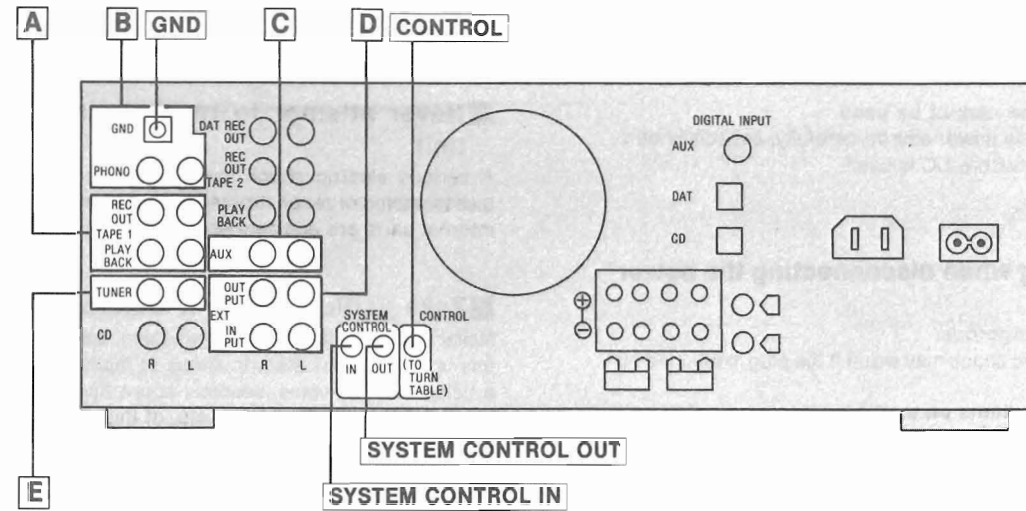

A "TAPE 1" terminals

Connect a first tape deck.

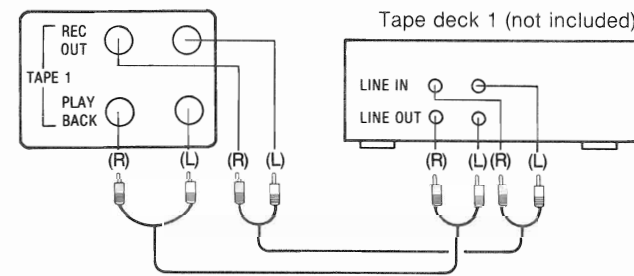

C "AUX" terminals

Connect a video disc player (Only the audio is connectable), etc.

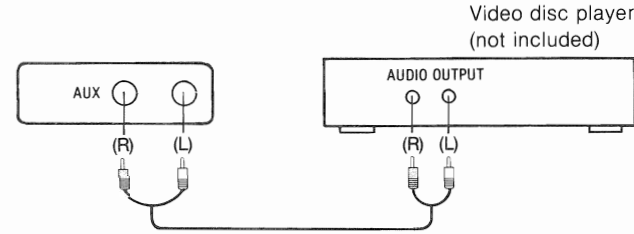

F "TAPE 2" terminals

Connect a video cassette recorder (for audio only) or a second tape deck.

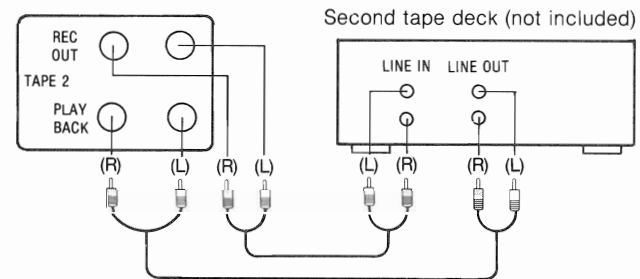

H "AUX" terminal (DIGITAL)

Connect a second compact disc player, etc.

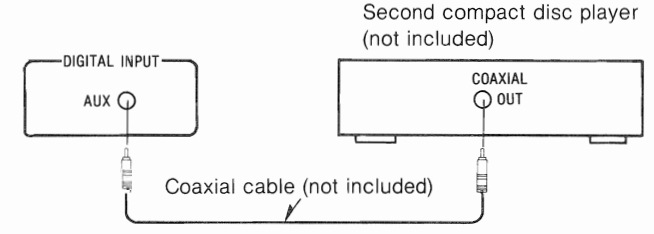

I "CD" terminal (DIGITAL)

Connect a compact disc player.

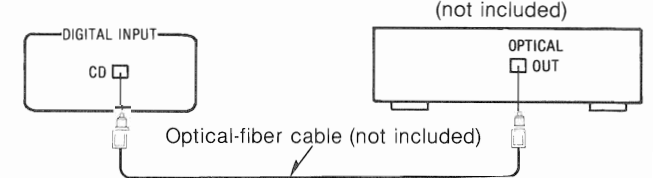

J "CD" terminals (ANALOG)

Connect a compact disc player.

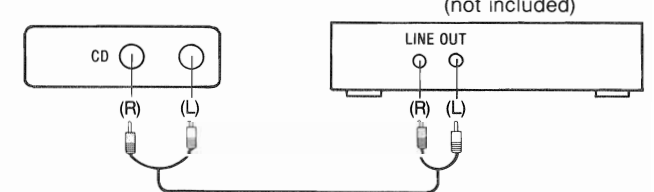

"SYSTEM CONTROL OUT" terminal

This terminal is used to connect a Technics tape deck with the control terminal.

B "PHONO" terminals

Connect a turntable.

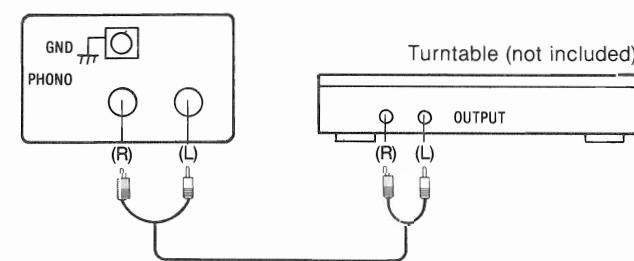

"GND" terminal

This terminal is for use with a turntable which has a ground wire.

"CONTROL" terminal

This terminal is used to connect a Technics turntable with the remote-control terminal.

D "EXT" terminals

Connect a graphic equalizer.

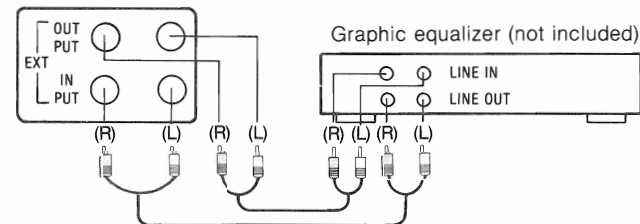

Note:

When these terminals are not in use, be sure to insert the "shorting" pins (included).

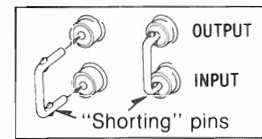

E "TUNER" terminals

Connect a tuner.

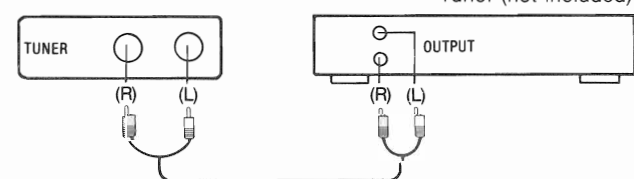

"SYSTEM CONTROL IN" terminal

This terminal is used to connect a Technics tuner with the control terminal.

G "DAT" terminals (DIGITAL)

Connect a digital audio tape deck. Recordings can be made to the digital audio tape deck.

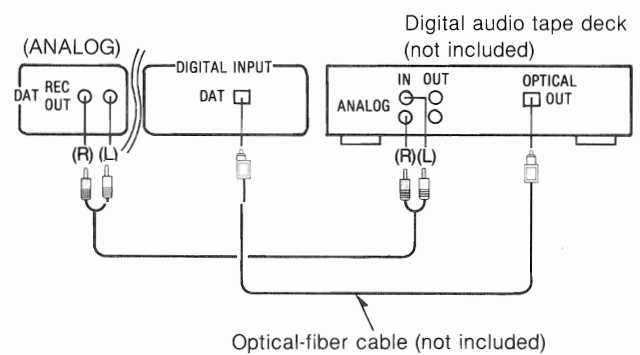

"DIGITAL INPUT" (DAT, CD) terminals of this unit

These terminals are protected by dust-protection caps to avoid damage by dust, etc. Remove the caps only when the "DIGITAL INPUT" terminals are to be used. When these terminals are not being used, attach the caps as shown in the illustration at the right.

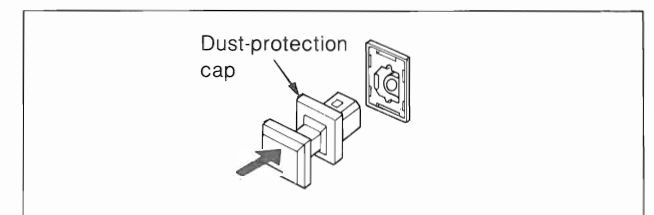

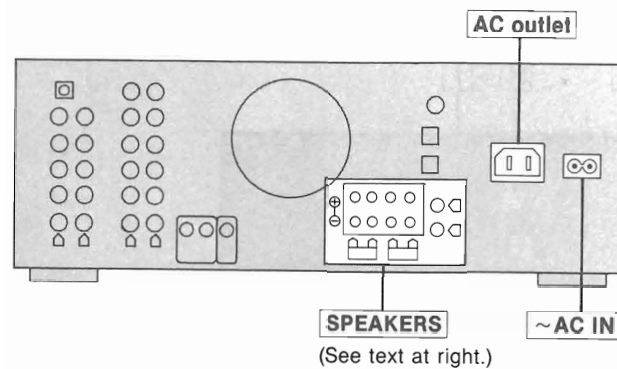

AC outlet ("AC OUTLET")

Do not connect video equipment (such as a TV, etc.) to the AC outlet of this unit. (This outlet is intended for audio equipment.) Do not exceed the indicated power ratings when connecting to this outlet.

"UNSWITCHED" outlet:

Power is always available, regardless of power switch. Audio equipment rated up to 60 W can be connected here.

AC power supply cord

Connect the AC power supply cord (included) after all other cables and cords are connected.

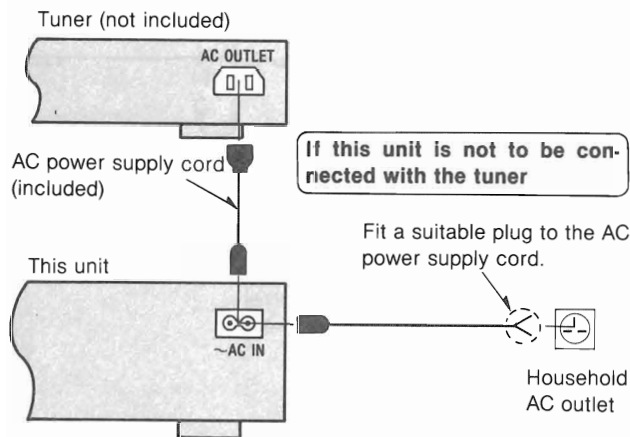

Connection of speaker systems

Three pairs of speaker systems (main, second, surround-sound) can be connected to this unit. Speaker systems that can be connected (to any of the speaker connection terminals of this unit) are speaker systems with an impedance of 8 to 16 ohms.

Main speaker systems (not included)

Connect to the "A" terminals.

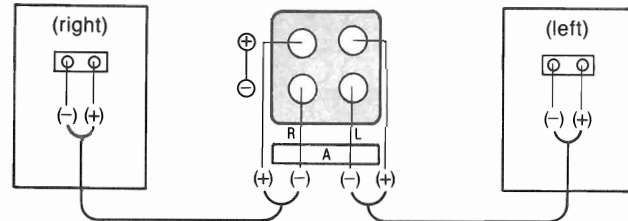

Second speaker systems (not included)

Connect to the "B" terminals.

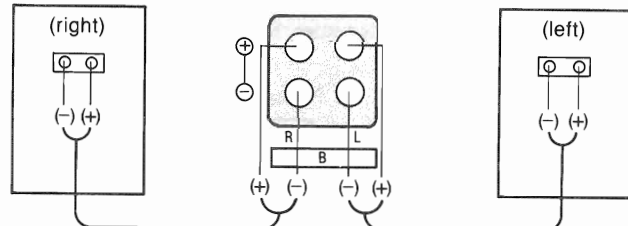

Surround-sound speaker systems (not included)

Connect to the "SURROUND" terminals.

- Be sure to connect both speaker systems. If only one side is connected, no sound will be heard.

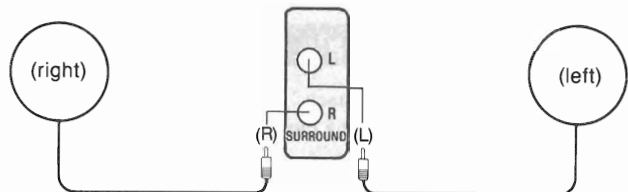

To connect cords to terminals

- 1 Strip off the outer covering, and twist the center conductor. Twist
- 2 Tilt the lever back and insert the cord.
- 3 Close the lever and pull the cord gently to be sure that it is secure.

Note: Be sure to only connect positive (+) cords to positive (+) terminals, and negative (-) cords to negative (-) terminals.

Note: To prevent damage to circuitry, never short-circuit the plus (+) and minus (-) speaker cords.

DIGITALIZATION OF AUDIO SIGNALS

Why digitize?

- Audio signals are analog signals with a continuous form.
- When these audio signals are subjected to repeated electronic processing (recording, playback, etc.), they become noisy and distortion occurs, thus resulting in deterioration of the sound quality.
- If these signals are digitized before processing, they have the following advantages that prevent deterioration of the sound quality:
 - ① Resistance to noise
 - ② Extremely low distortion
 - ③ Flat, even frequency response

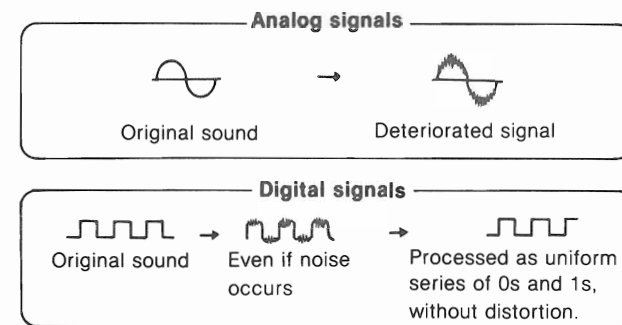

How signals are digitized

If it is known to what degree of minuteness the human ear can distinguish sounds, it is then possible, by using that data as the standard reference, to digitize signals by dividing analog signals into minute pieces, after which they can be transmitted with a high degree of precision, and thereafter recorded and played back in the digitized format.

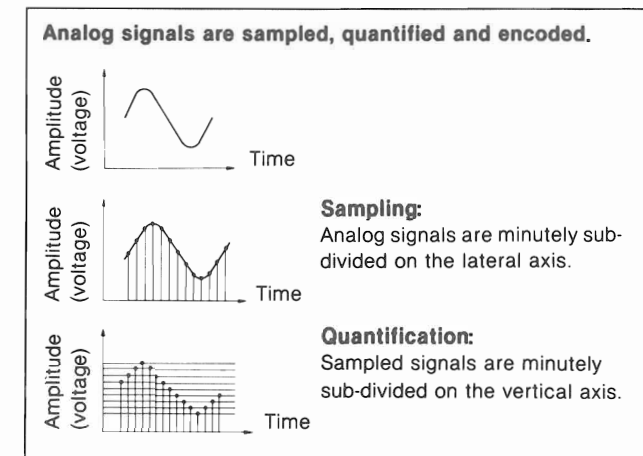

Digitalization example (recording to CD and play of CD)

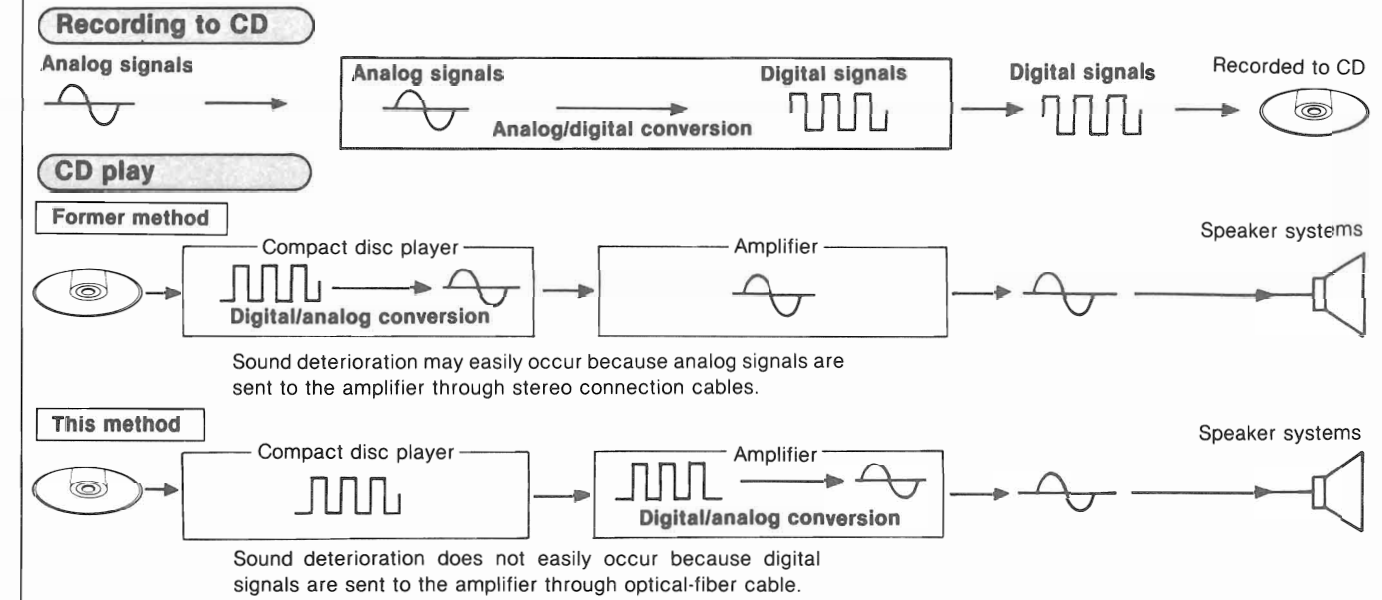

What the sampling frequency is

The sampling frequency expresses the degree of minuteness to which signals can be sub-divided, relative to a certain specified time interval, during sampling. For compact disc sound: Analog signals are sub-divided 44,100 times (i.e., 44.1 kHz) during one second. This 44.1 kHz is, therefore, the sampling frequency for compact disc sound.

What analog/digital conversion is

Audio signals (analog signals) are taken out (sampled) at certain fixed time intervals. The points at which this sampling frequency occurs are digitally encoded and converted to digital signals.

What digital/analog conversion is

Each sampling frequency point is returned (converted) to voltage, thus converting digital signals to the analog signals that we can hear.

DISASS

Ref. No. 1	Procedure 1
Ref. No. 3	Procedure 1→2→3
Ref. No. 4	Procedure 1→2→4

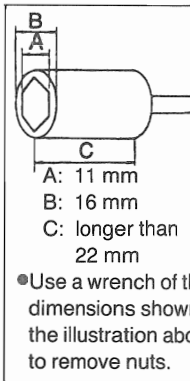

DIGITALIZATION OF AUDIO SIGNALS

Why digitize?

- Audio signals are analog signals with a continuous form.
- When these audio signals are subjected to repeated electronic processing (recording, playback, etc.), they become noisy and distortion occurs, thus resulting in deterioration of the sound quality.
- If these signals are digitized before processing, they have the following advantages that prevent deterioration of the sound quality:
 - ① Resistance to noise
 - ② Extremely low distortion
 - ③ Flat, even frequency response

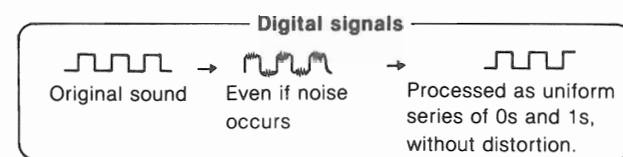
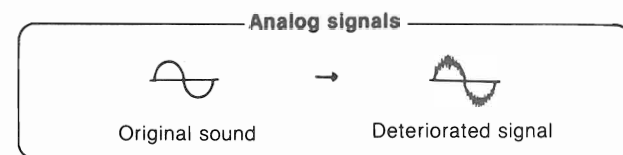

How signals are digitized

If it is known to what degree of minuteness the human ear can distinguish sounds, it is then possible, by using that data as the standard reference, to digitize signals by dividing analog signals into minute pieces, after which they can be transmitted with a high degree of precision, and thereafter recorded and played back in the digitized format.

Analog signals are sampled, quantified and encoded.

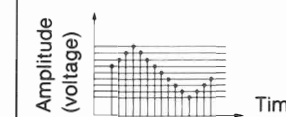
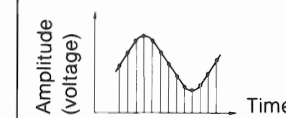
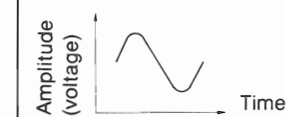

Sampling:
Analog signals are minutely sub-divided on the lateral axis.

Quantification:
Sampled signals are minutely sub-divided on the vertical axis.

Digitalization example (recording to CD and play of CD)

Recording to CD

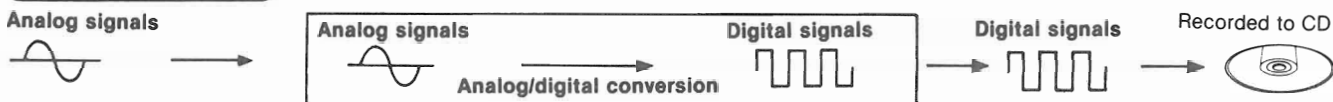

CD play

Former method

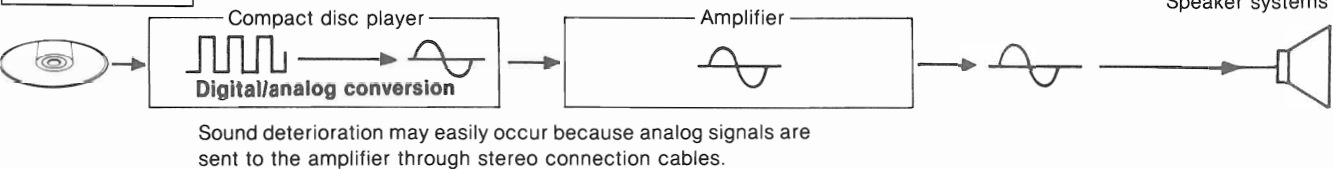

This method

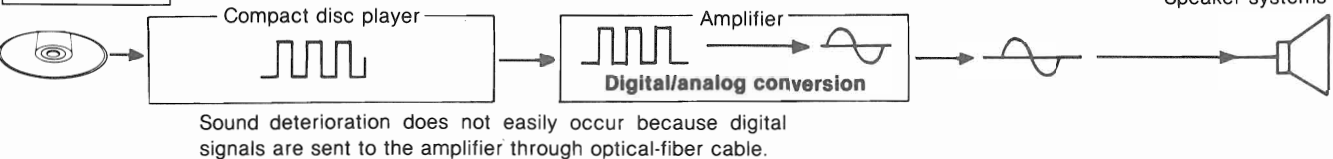

What the sampling frequency is

The sampling frequency expresses the degree of minuteness to which signals can be sub-divided, relative to a certain specified time interval, during sampling.
For compact disc sound:
Analog signals are sub-divided 44,100 times (i.e., 44.1 kHz) during one second.
This 44.1 kHz is, therefore, the sampling frequency for compact disc sound.

What analog/digital conversion is

Audio signals (analog signals) are taken out (sampled) at certain fixed time intervals. The points at which this sampling frequency occurs are digitally encoded and converted to digital signals.

What digital/analog conversion is

Each sampling frequency point is returned (converted) to voltage, thus converting digital signals to the analog signals that we can hear.

DISASSEMBLY INSTRUCTIONS

<p>Ref. No. 1</p>	<p>Removal of the Cabinet</p>	<p>Ref. No. 2</p>	<p>Removal of the Front Panel</p>
<p>Procedure 1</p>	<p>Remove the 6 screws (1~6).</p>	<p>Procedure 1→2</p>	<p>1. Remove the flat cables (J501, J502).</p> <p>2. Remove the 3 screws (1~3).</p> <p>3. Remove the front panel in the direction of the arrow.</p>
<p>Ref. No. 3</p>	<p>Removal of the Power Switch/Headphones P.C.B.</p>	<p>Ref. No. 4</p>	<p>Removal of the FL Drive P.C.B.</p>
<p>Procedure 1→2→3</p>	<p>Remove the 2 screws (1, 2).</p>	<p>Procedure 1→2→4</p>	<p>How to remove the flat cable</p> <p>1. Lift the connector. 2. Pull out the flat cable.</p>
<p>Ref. No. 4</p>	<p>Removal of the FL Drive P.C.B.</p>	<p>Ref. No. 5</p>	<p>Removal of the Front Panel</p>
<p>Procedure 1→2→4</p>	<p>1. Pull out the 3 knobs (1~3). 2. Remove the 3 nuts (4~6).</p>	<p>Procedure 1→2→4</p>	<p>3. Remove the 7 screws (7~13).</p>

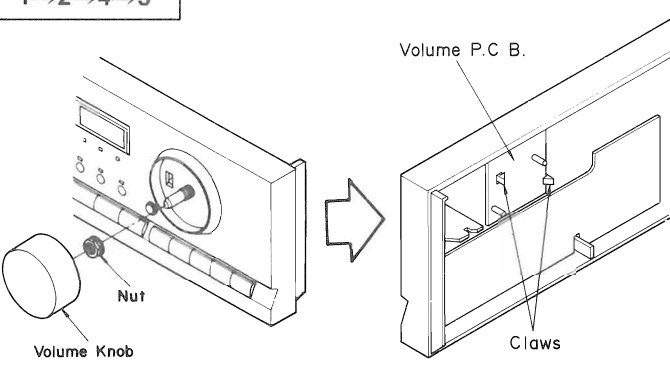
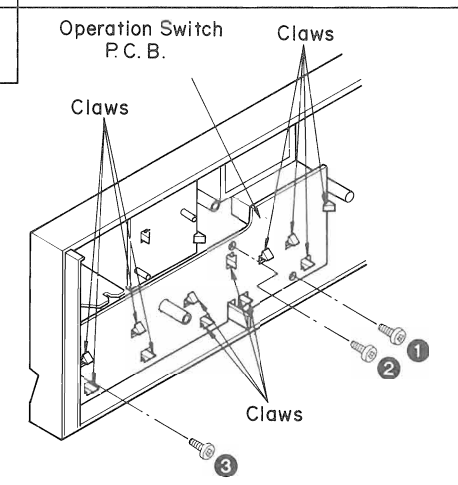
Ref. No. 5	Removal of the Volume P.C.B.	Ref. No. 6	Removal of the Operation Switch P.C.B.
Procedure 1→2→4→5	 <p>1. Pull out the volume knob. 2. Remove the 1 nut. 3. Release the 2 claws.</p>	 <p>1. Remove the 3 screws (1~3). 2. Release the 12 claws.</p>	

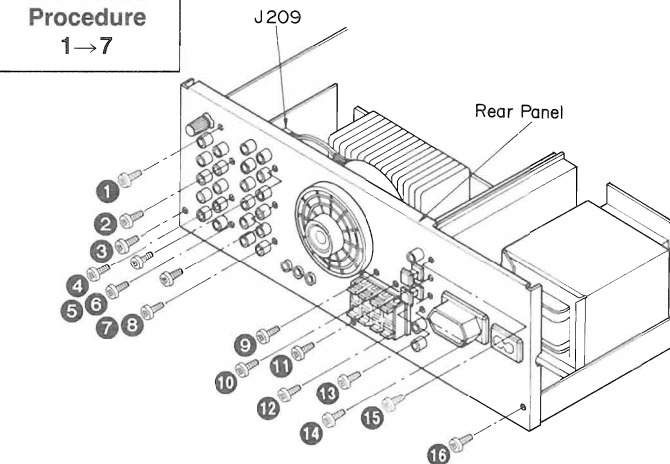
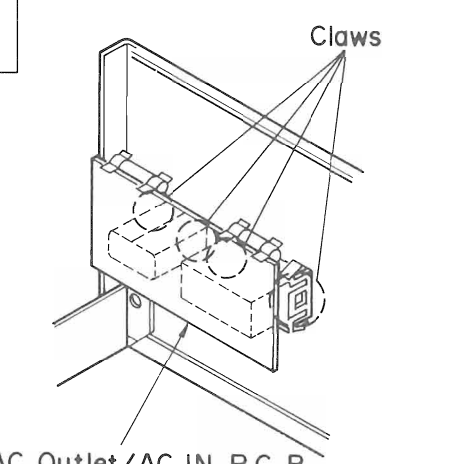
Ref. No. 7	Removal of the Rear Panel	Ref. No. 8	Removal of the AC OUTLET/AC IN P.C.B.
Procedure 1→7	 <p>1. Remove the 1 connector (J209). 2. Remove the 16 screws (1~16).</p>	 <p>●Release the 4 claws.</p>	

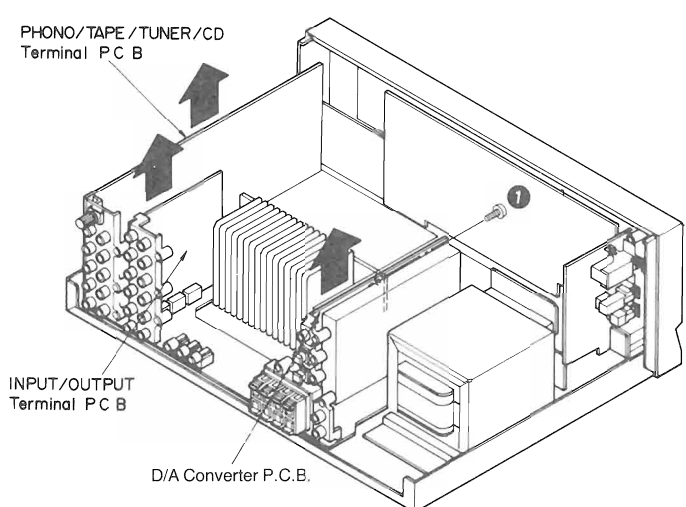
Ref. No. 9	Removal of the D/A Converter P.C.B., PHONO/TAPE/TUNER/CD Terminal P.C.B. and INPUT/OUTPUT Terminal P.C.B.		
Procedure 1→7→9	<div style="display: flex;"> <div style="width: 30%;"> <p>■ Removal of the D/A Converter P.C.B.</p> <p>1. Remove the 1 screw (1). 2. Remove the D/A Converter P.C.B. in the direction of the arrow.</p> <p>■ Removal of the PHONO/TAPE/TUNER/CD Terminal P.C.B.</p> <p>●Remove the PHONO/TAPE/TUNER/CD Terminal P.C.B. in the direction of the arrow.</p> <p>■ Removal of the INPUT/OUTPUT Terminal P.C.B.</p> <p>●Remove the INPUT/OUTPUT Terminal P.C.B. in the direction of the arrow.</p> </div> <div style="width: 70%;">  </div> </div>		

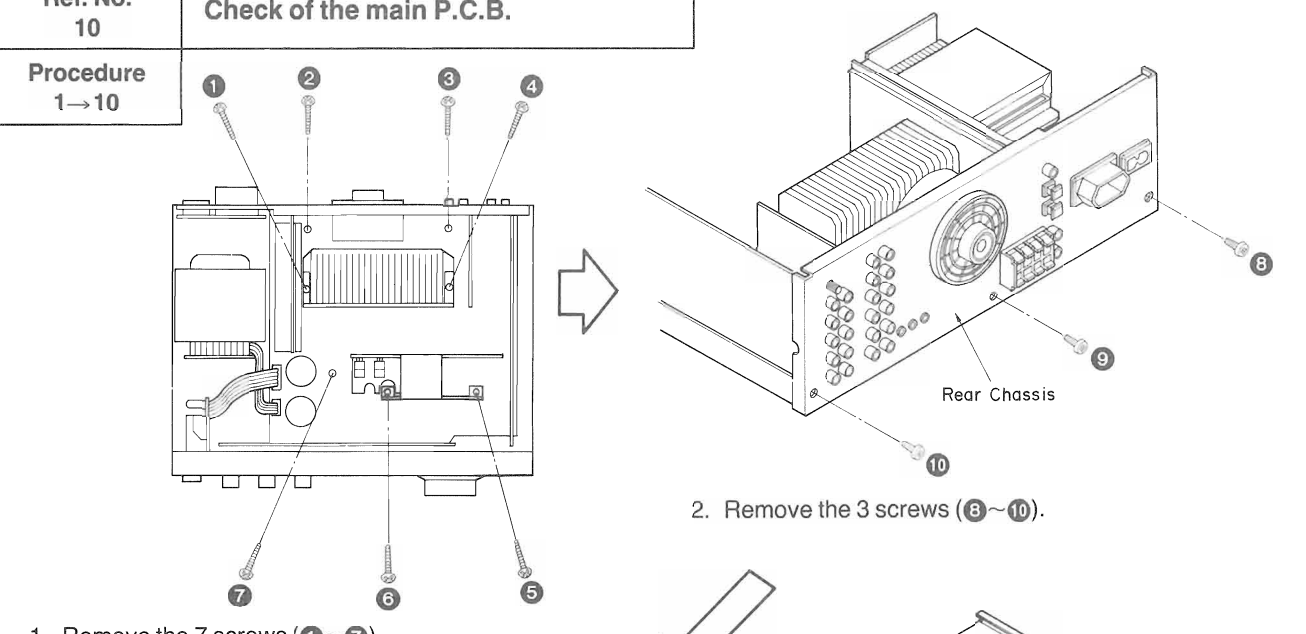
Ref. No. 10	Check of the main P.C.B.		
Procedure 1→10	 <p>1. Remove the 7 screws (1~7). 2. Remove the 3 screws (8~10). 3. Remove the 3 screws (11~13). 4. Remove the front panel in the direction of the arrow. *Connect 2 flat cables (J501, J502). 5. Remove the bottom chassis. 6. Reinstall the front panel to the main P.C.B.</p>		

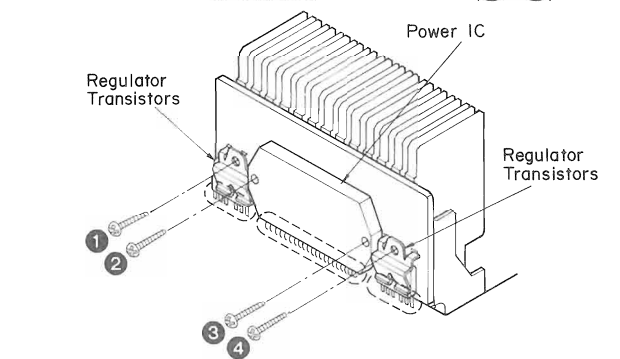
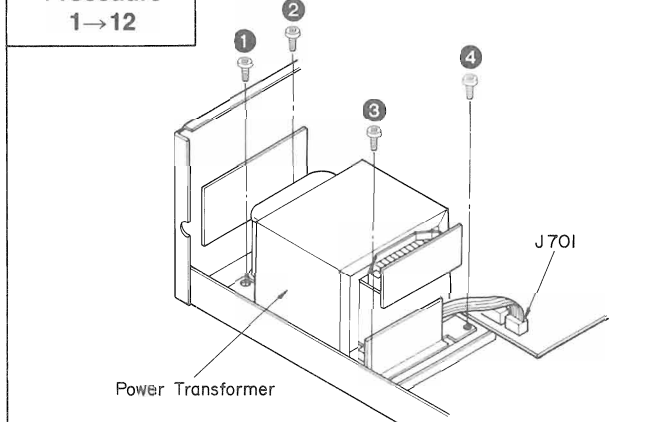
Ref. No. 11	Removal of the Power IC and Regulator Transistor	Ref. No. 12	Removal of the Power Transformer
Procedure 1→10→11	 <p>1. Unsolder the power IC or regulator transistor. 2. Remove the 4 screws (1~4).</p> <p>Note: When mounting the power IC, or regulator transistor apply silicon terminal compound (SZZ0L15) to the rear of the power IC or regulator transistor.</p>	 <p>1. Remove the 1 flat cable (J701). 2. Remove the 4 screws (1~4).</p>	

■ MEASUREMENTS AND ADJUSTMENTS

Control positions and equipment used.

- Volume knob ∞ (Minimum)
- Speaker selector (A) off
- Speaker selector (B) off
- DC electronic voltmeter (EVM) 2

VOLTAGE CONTROL(V)AMP. IDLING (ICQ) ADJUSTMENT

1. Test equipment connection is shown in figure. (Connect the DC EVM on both channels.)
2. Completely turn the (V) amp. Adjusting volumes (VR1451, VR1452) counter-clockwise.
3. Turn ON the set when it is cold, and 15 sec. later, adjust VR1451 and VR1452 so that the voltage is 40 mV. Also, check that the voltage is 30~65 mV (standard: 35 mV) after lapse of 10~15 minutes. (Below 35 mV after lapse of 60 min.)

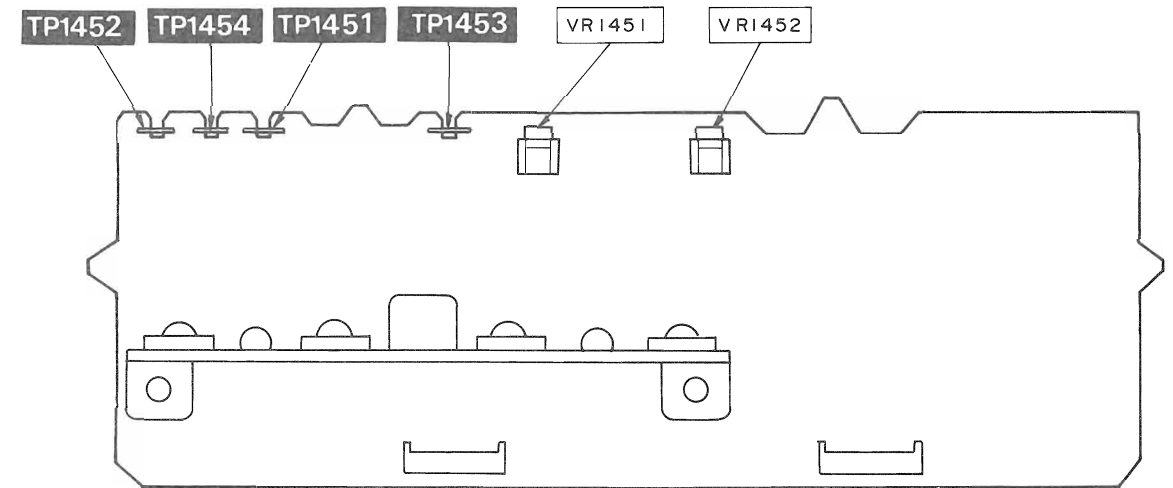
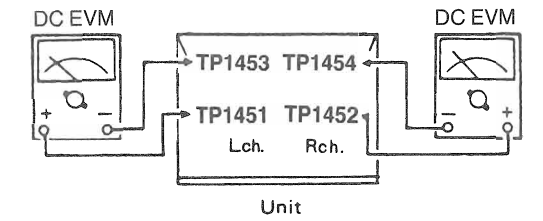

● Test point

- TP1451...L ch ⊕ Voltage control amp I_{CO} adj.
- TP1453...L ch ⊖ Voltage control amp I_{CO} adj.
- TP1452...R ch ⊕ Voltage control amp I_{CO} adj.
- TP1454...R ch ⊖ Voltage control amp I_{CO} adj.

● Adjustment VR

- VR1451...L ch Voltage control amp I_{CO} adj.
- VR1452...R ch Voltage control amp I_{CO} adj.

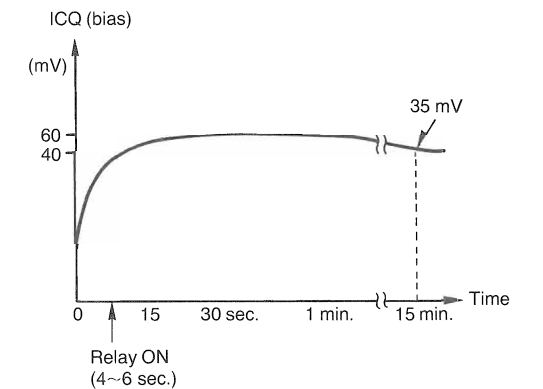

Ref. No. 13	Removal of the V. Control Amp P.C.B. and V. Control Amp Transistor	
Procedure 1→13		
	<ol style="list-style-type: none"> 1. Remove the 2 screws (1, 2). 2. Remove the V. Control Amp P.C.B. in the direction of the arrow. 	<ol style="list-style-type: none"> 3. Unsolder the V. Control Amp transistor. 4. Remove the 4 screws (3~6). <p>Note: When mounting the transistor, apply silicon terminal compound (SZZ0L15) to the rear of the transistor.</p>

Ref. No. 14	Removal of the Fan Motor	
Procedure 1→14	<ol style="list-style-type: none"> 1. Remove the 1 connector (J209). 2. Release the 3 claws. 	<ol style="list-style-type: none"> 3. Insert a screwdriver at the root of the cooling fan. Force it out of the motor shaft. 4. Remove the motor cover by used ⊖ screwdriver. 5. Remove the motor from the fan casing. 6. When mounting the motor fan, align the fan casing's projection with the hole of the fan motor.

“ATTENTION SERVICER”
Some chassis components may have sharp edges. Be careful when disassembling and servicing.

● Replacement of the Foot.

1. Remove the 4 heat melted posts on the chassis with a pair of nippers or similar tool.
2. To replace the foot (RKA0011) on the chassis, melt the 4 posts with a soldering iron.

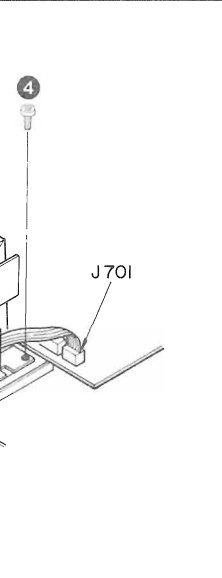
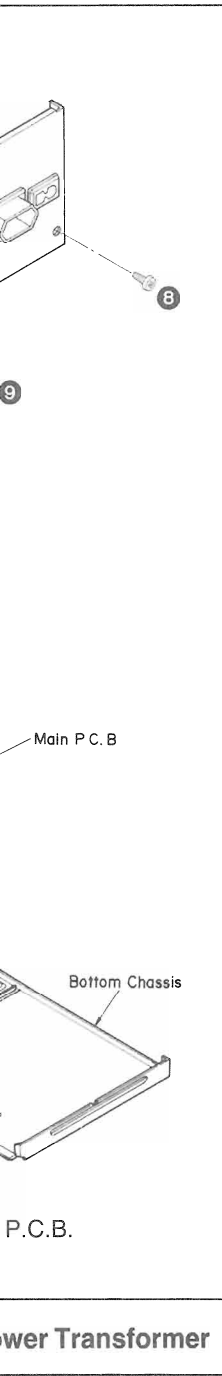
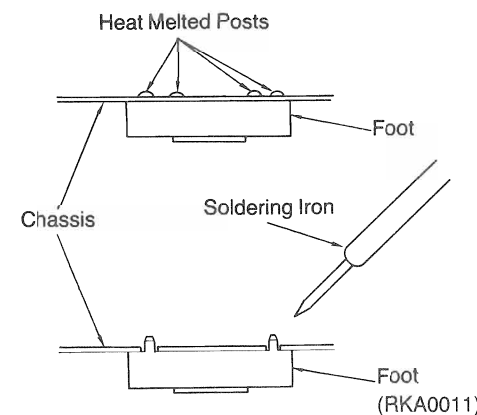

SCHEMATIC DIAGRAM

(Parts list on pages 33-35, 39-41)

A D/A CONVERTER CIRCUIT

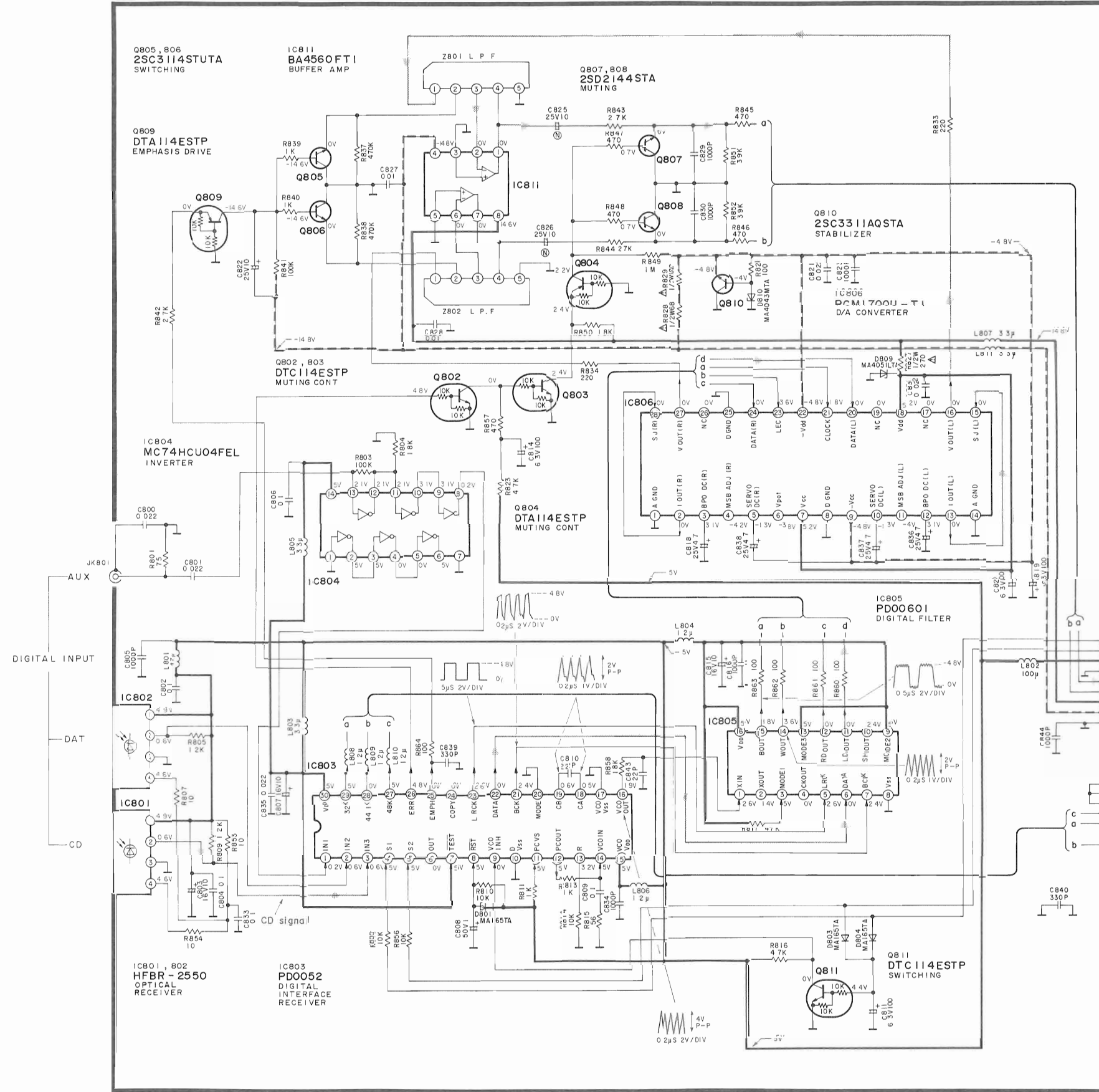

B PHONO/TAPE/TUNER/CD TERMINAL CIRCUIT

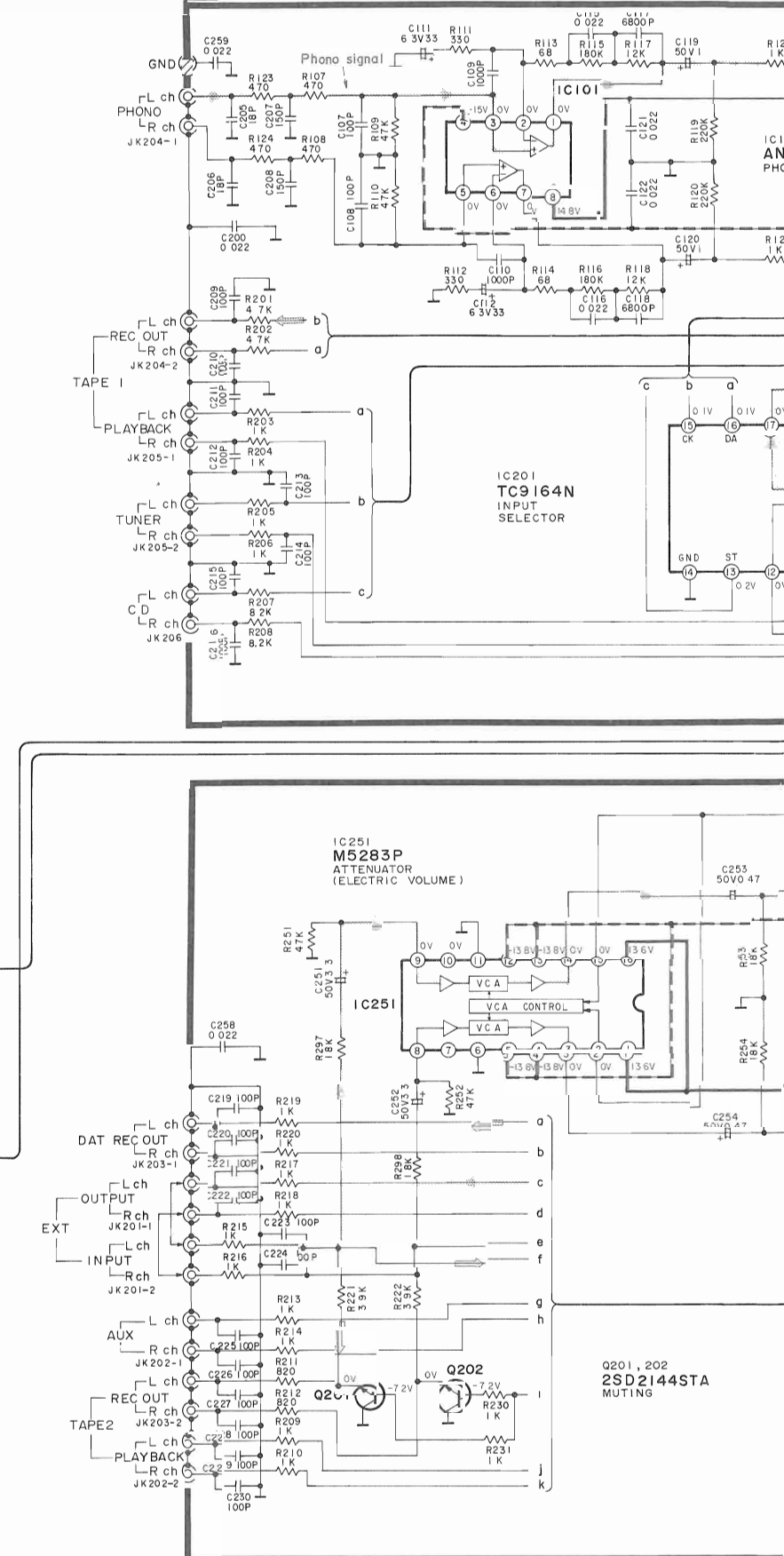

C INPUT OUTPUT TERMINAL CIRCUIT



CD TERMINAL CIRCUIT

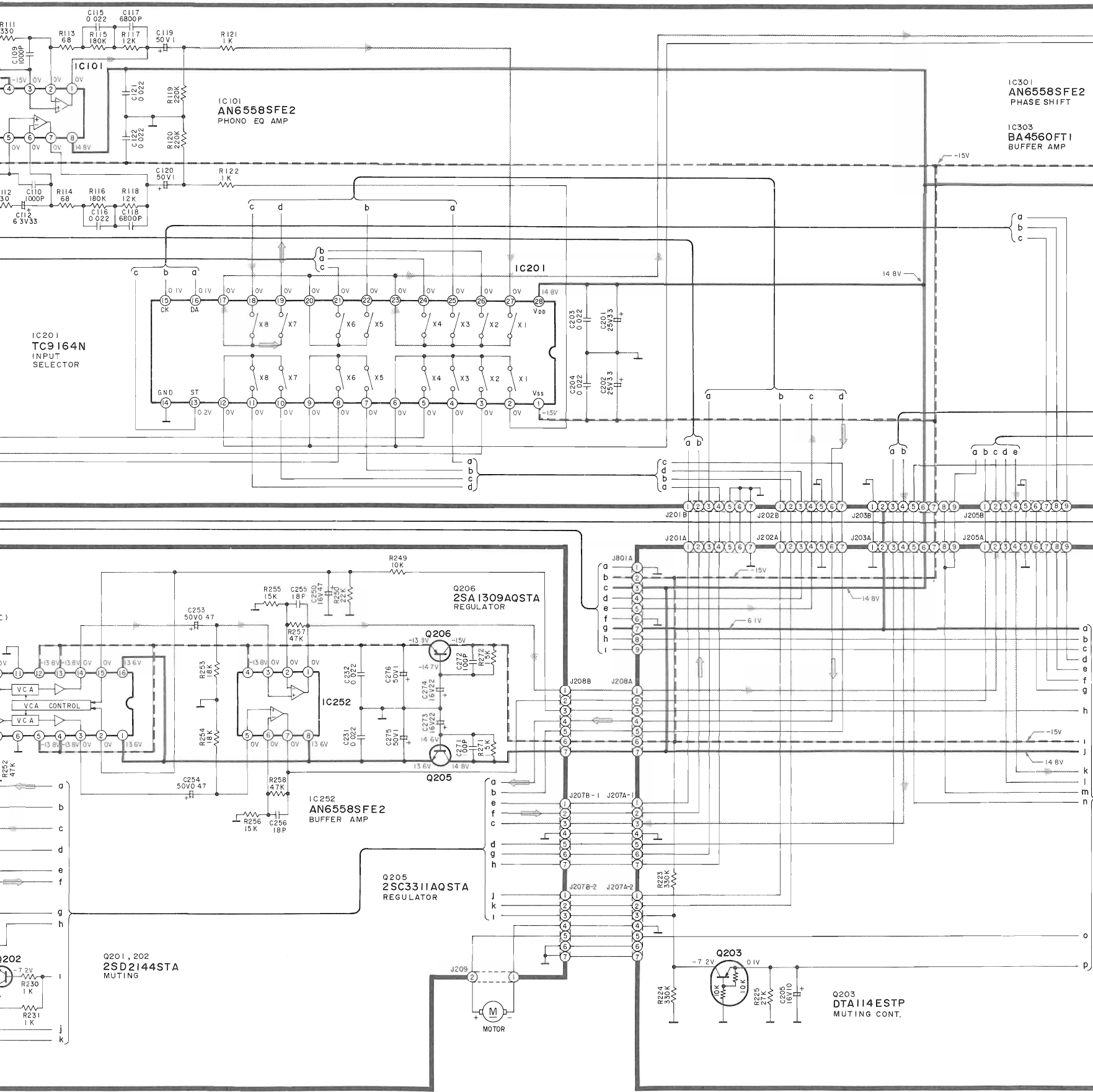

D MAIN CIRCUIT

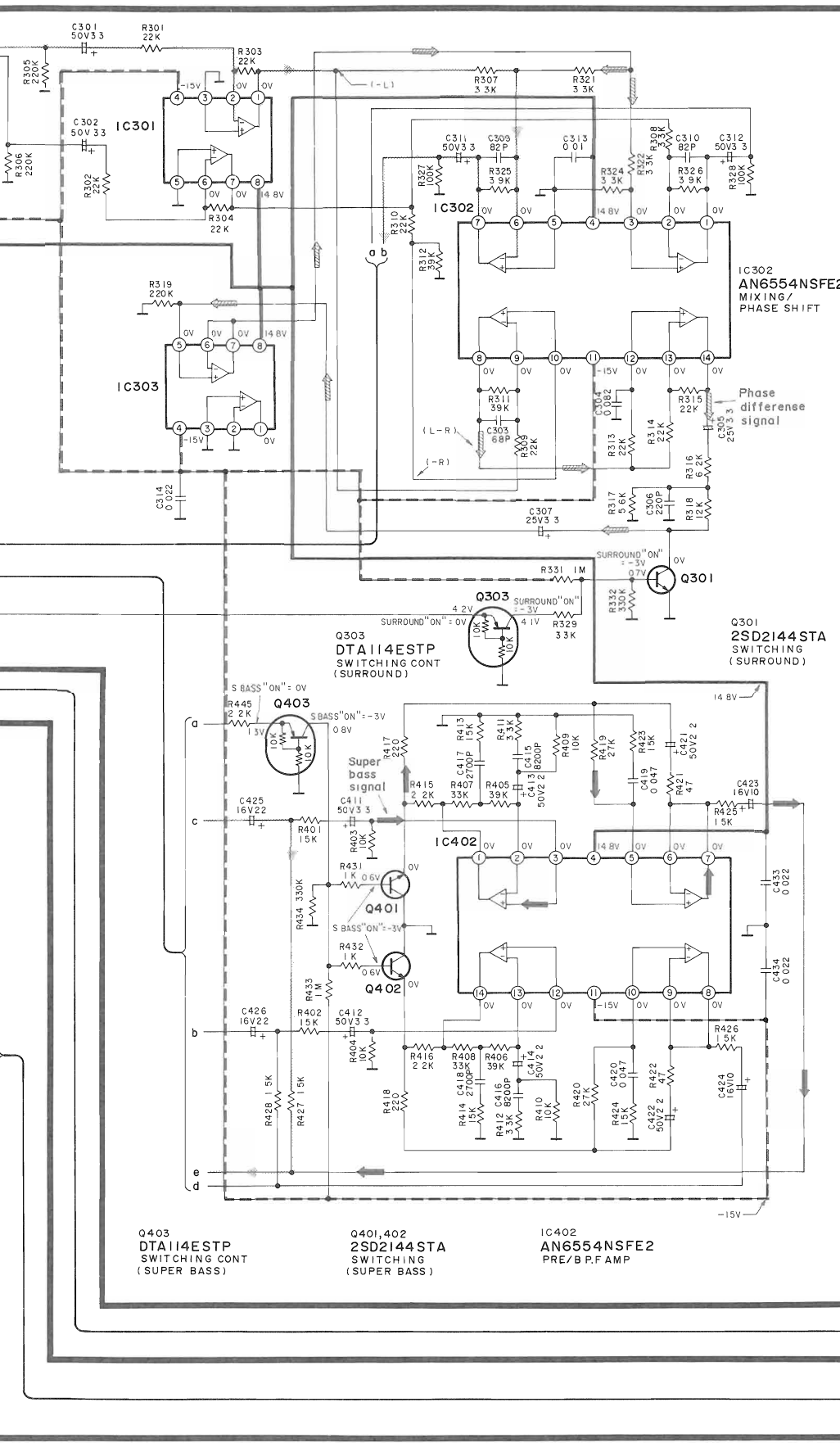

FINAL CIRCUIT

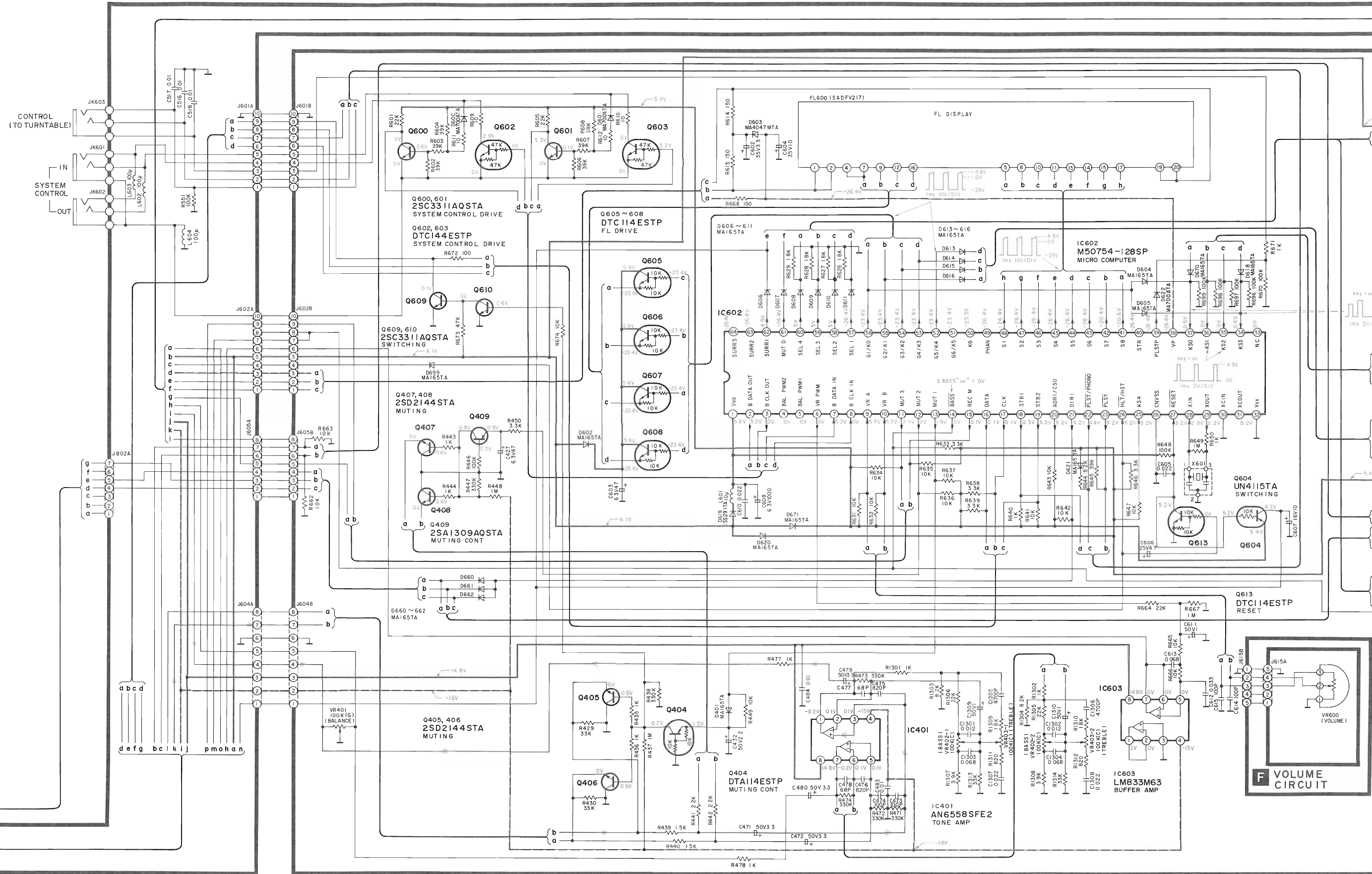

E FL DRIVE CIRCUIT

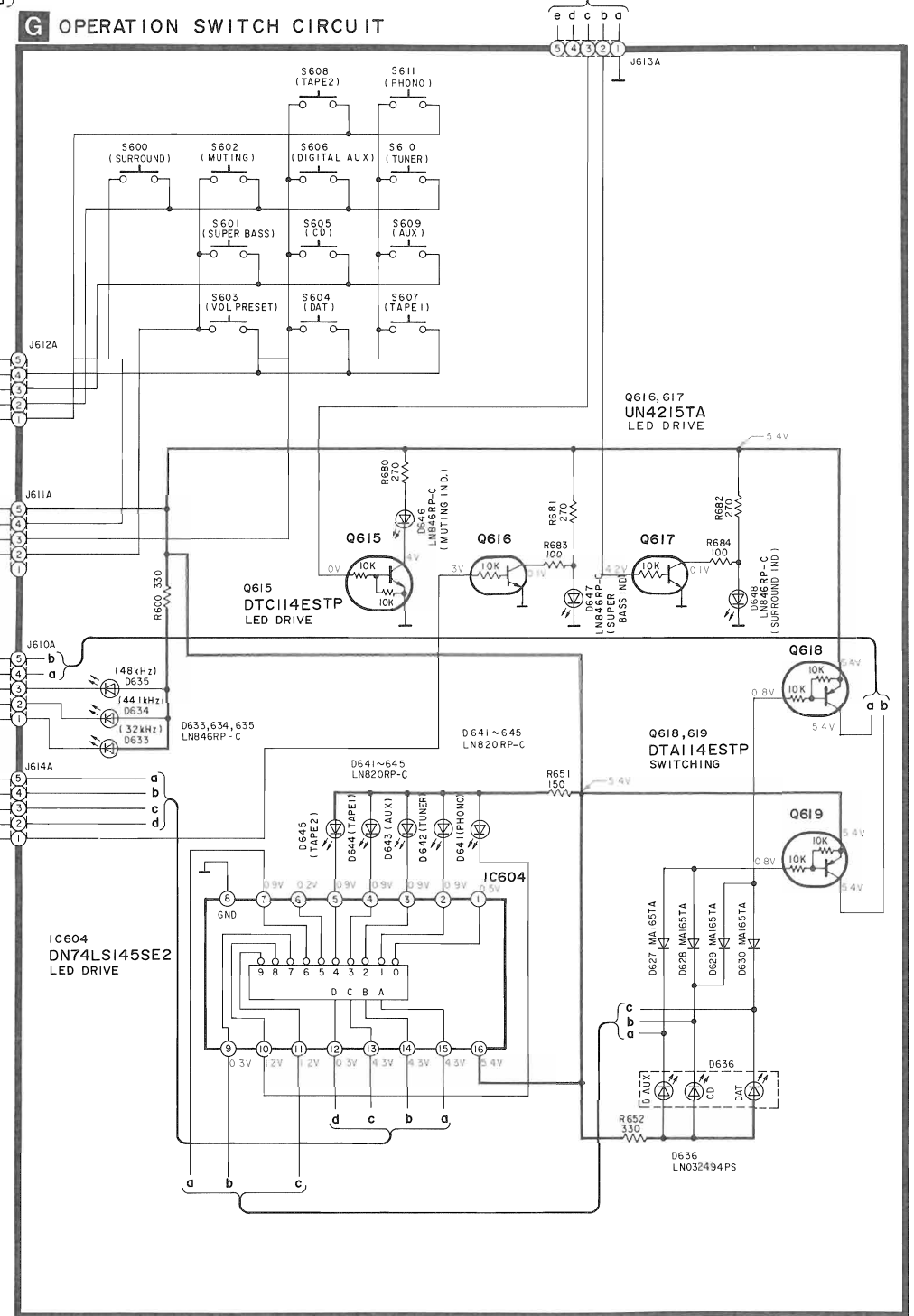
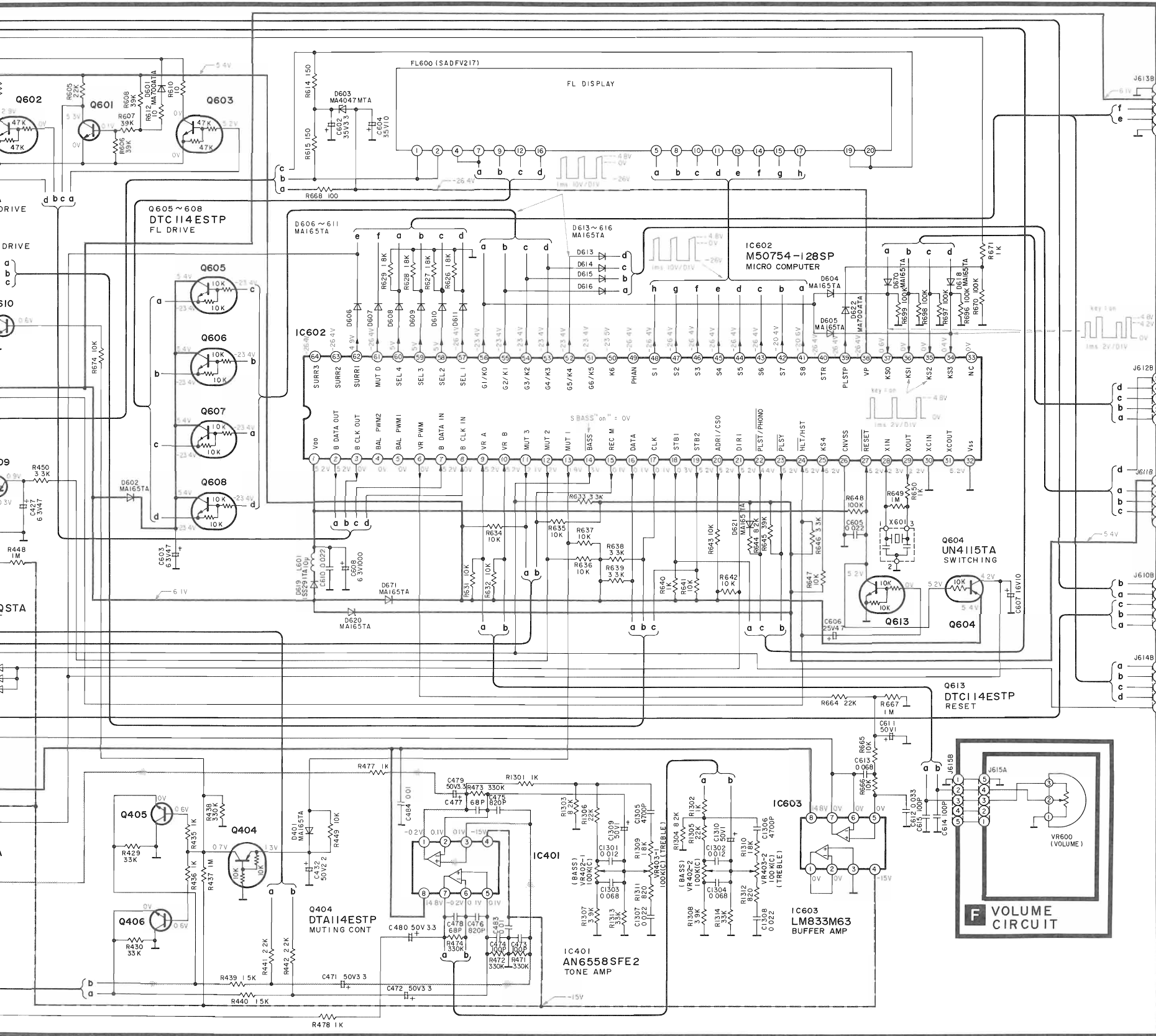

H V. CONTROL AMP CIRCUIT

Voltage control amp. ICQ adj. test point (L ch)

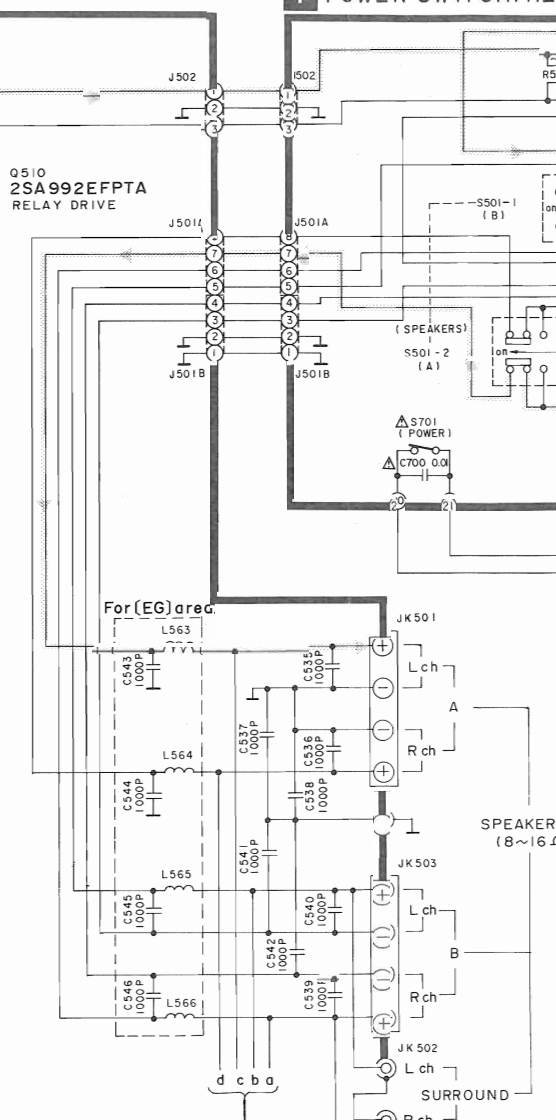
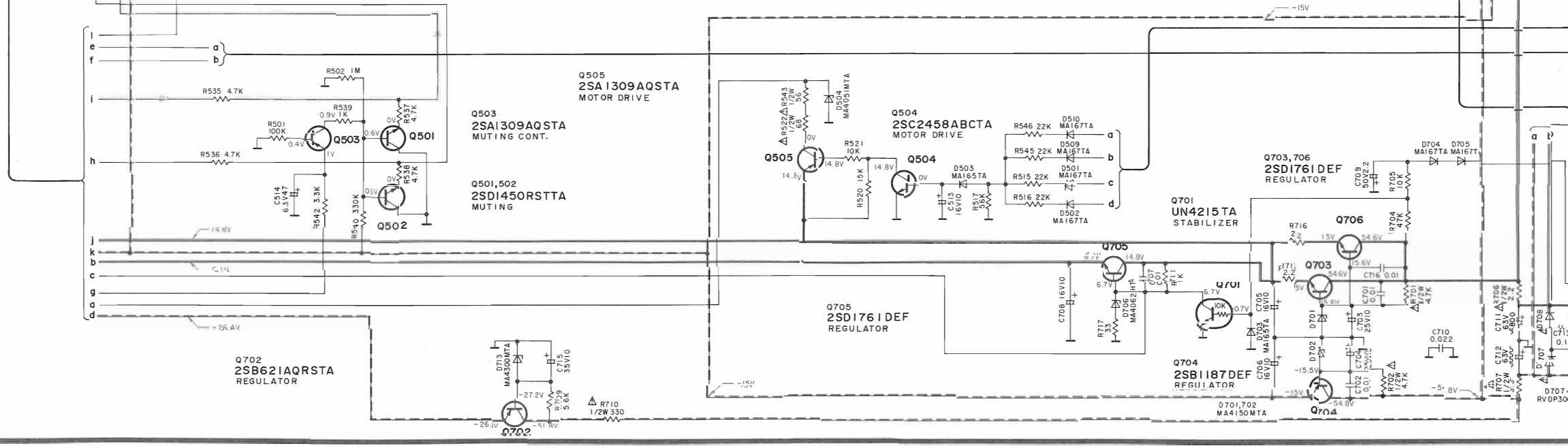
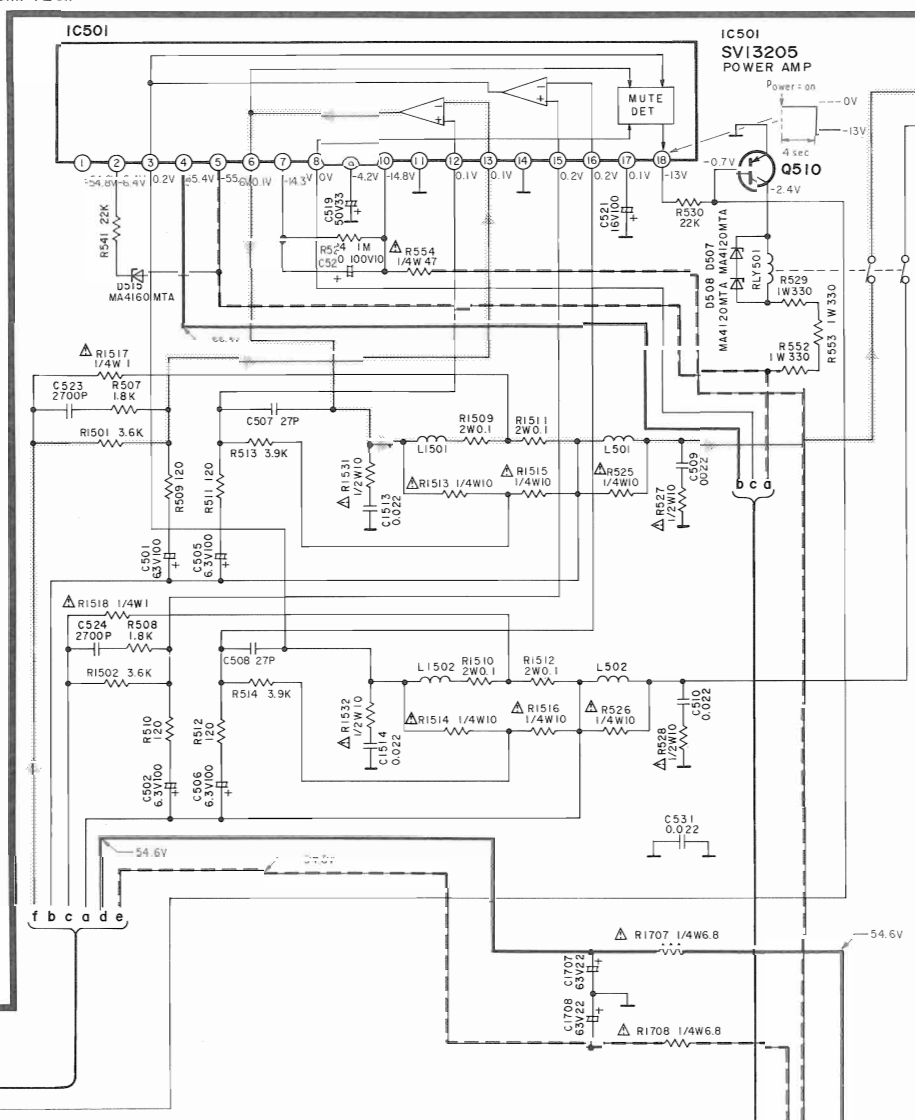
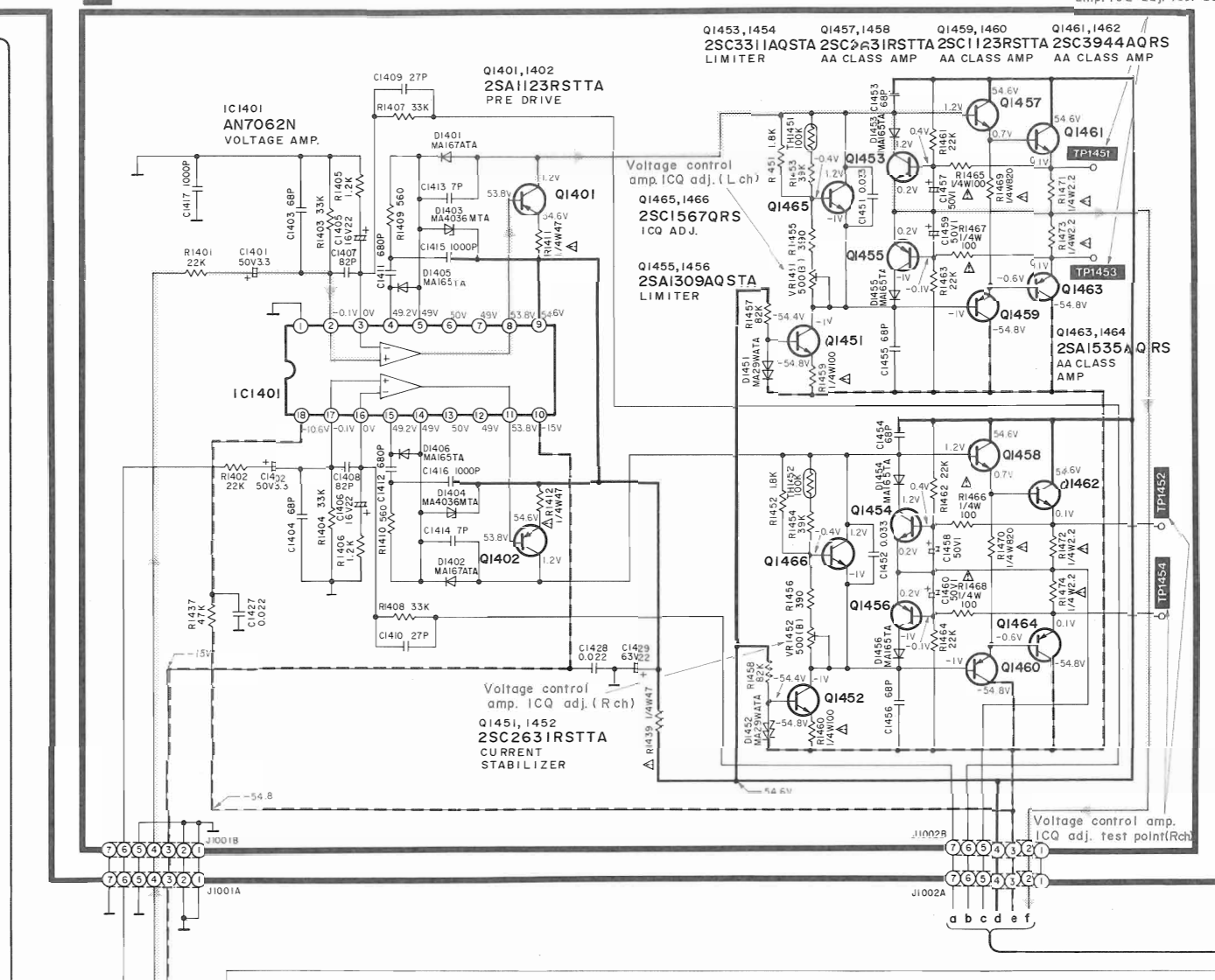

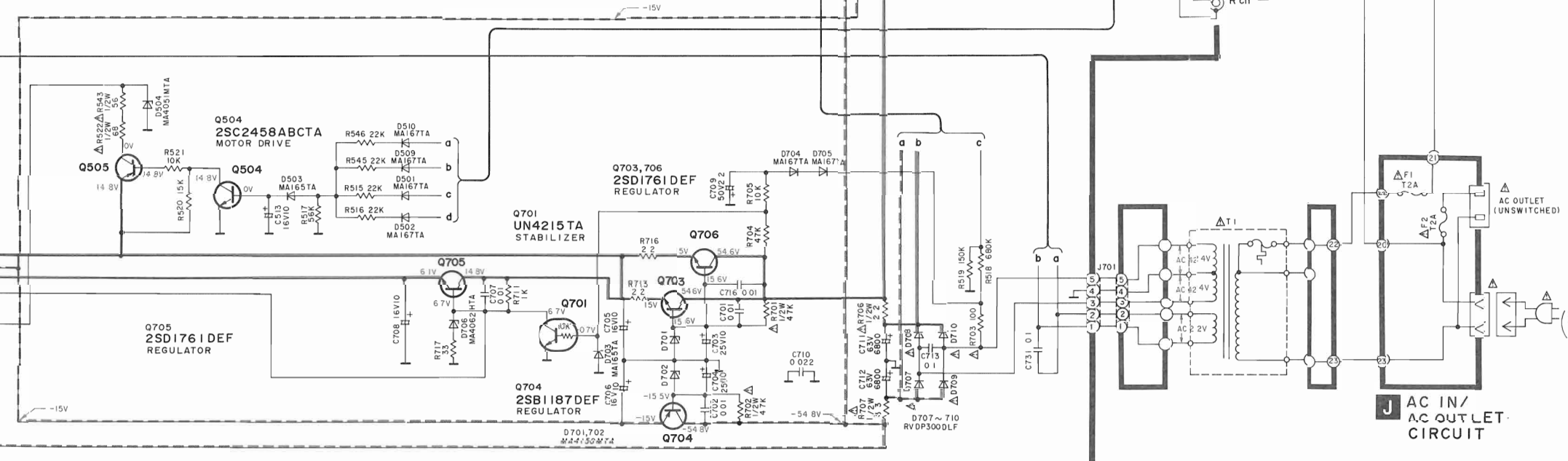
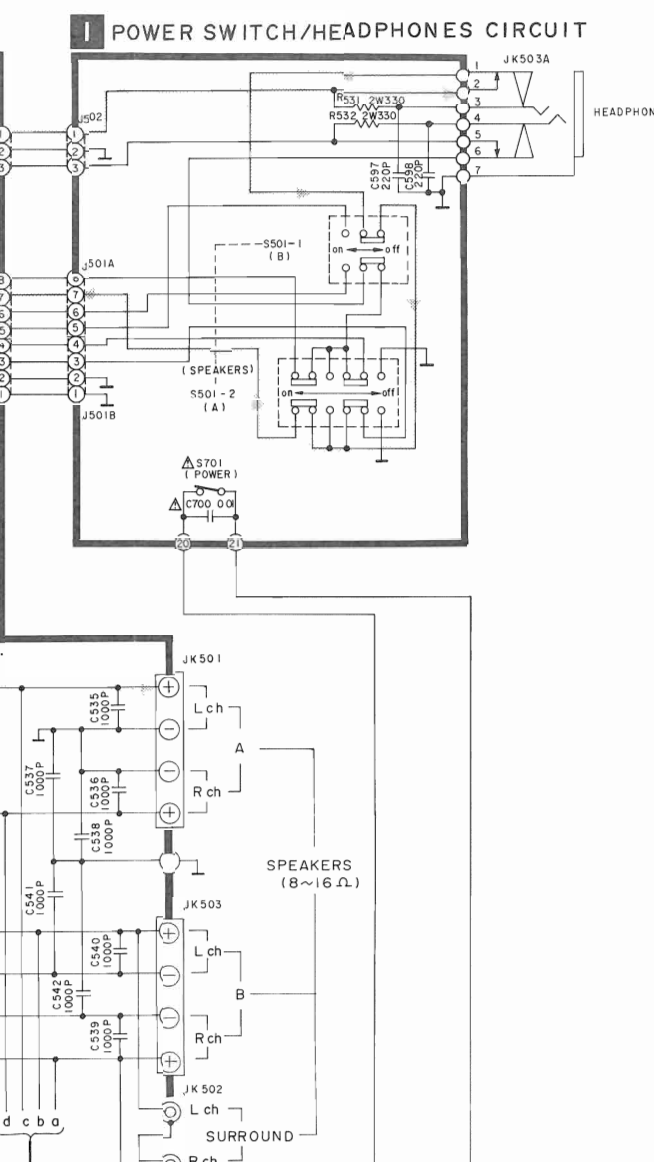
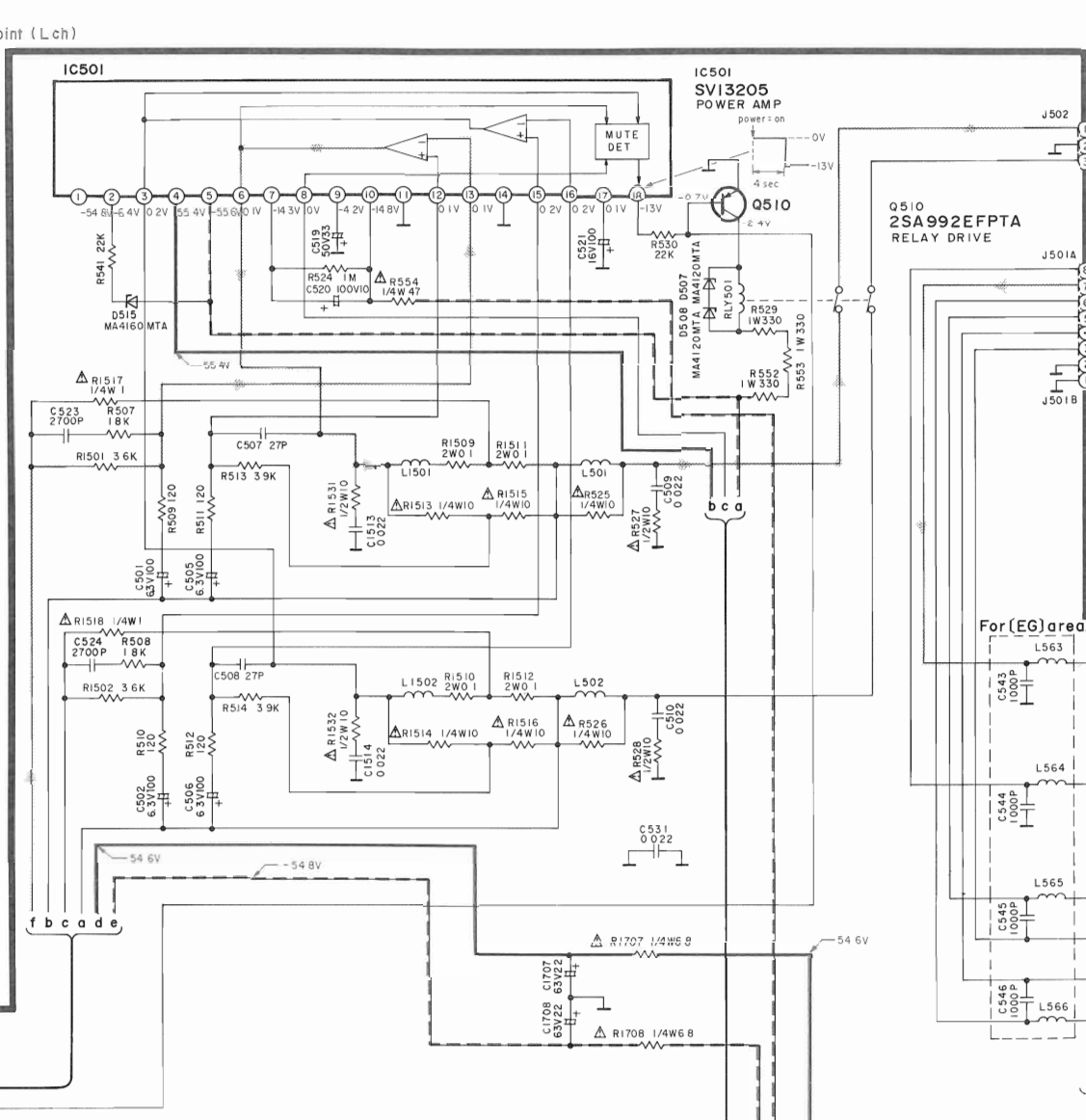
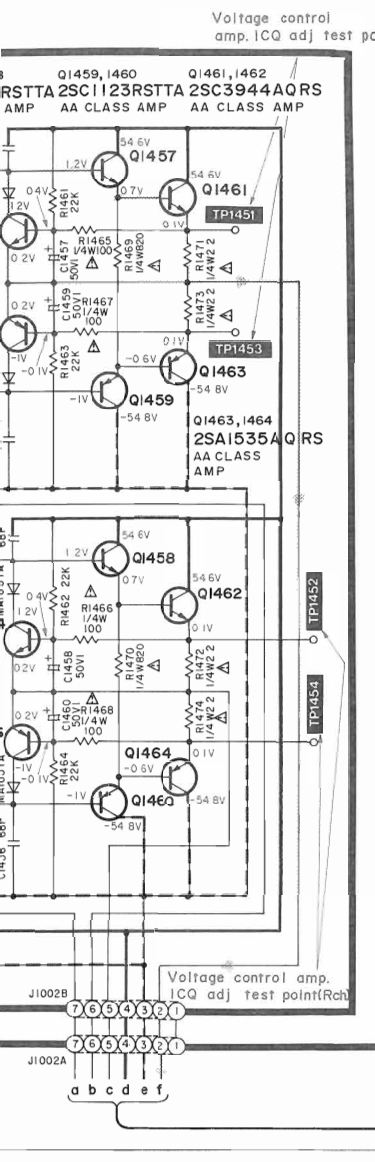

- Notes:**
- S501-1 : Speaker B selector switch in "OFF" position.
 - S501-2 : Speaker A selector switch in "ON" position.
 - S600 : Surround-sound switch in "OFF" position.
 - S601 : Super bass switch in "OFF" position.
 - S602 : Audio muting switch in "OFF" position.
 - S603 : Volume preset switch in "OFF" position.
 - S604~S611 : Input selector switches.
 - S604: DAT, S605: CD, S606: DIGITAL AUX
 - S607: TAPE1, S608: TAPE2, S609: AUX
 - S610: TUNER, S611: PHONO
 - S701 : Power switch in "ON" position.

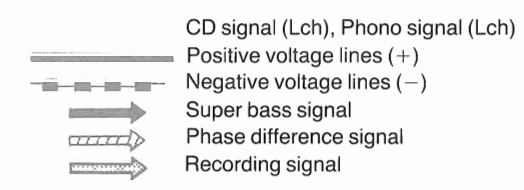

CD signal (Lch), Phono signal (Lch)

•Indicated voltage values are the standard values for the unit measured by the DC electronic circuit tester (high-impedance) with the chassis taken as standard. Therefore, there may exist some errors in the voltage values, depending on the internal impedance of the DC circuit tester.

•Important safety notice:
Components identified by Δ mark have special characteristics important for safety. When replacing any of these components, use only manufacturer's specified parts.

***Caution!**
IC and LSI are sensitive to static electricity. Secondary trouble can be prevented by taking care during repair.
•Cover the parts boxes made of plastics with aluminum foil.
•Ground the soldering iron.
•Put a conductive mat on the work table.
•Do not touch the legs of IC or LSI with the fingers directly.

PRINTED CIRCUIT BOARDS (Parts list on pages 33~35, 39~41)

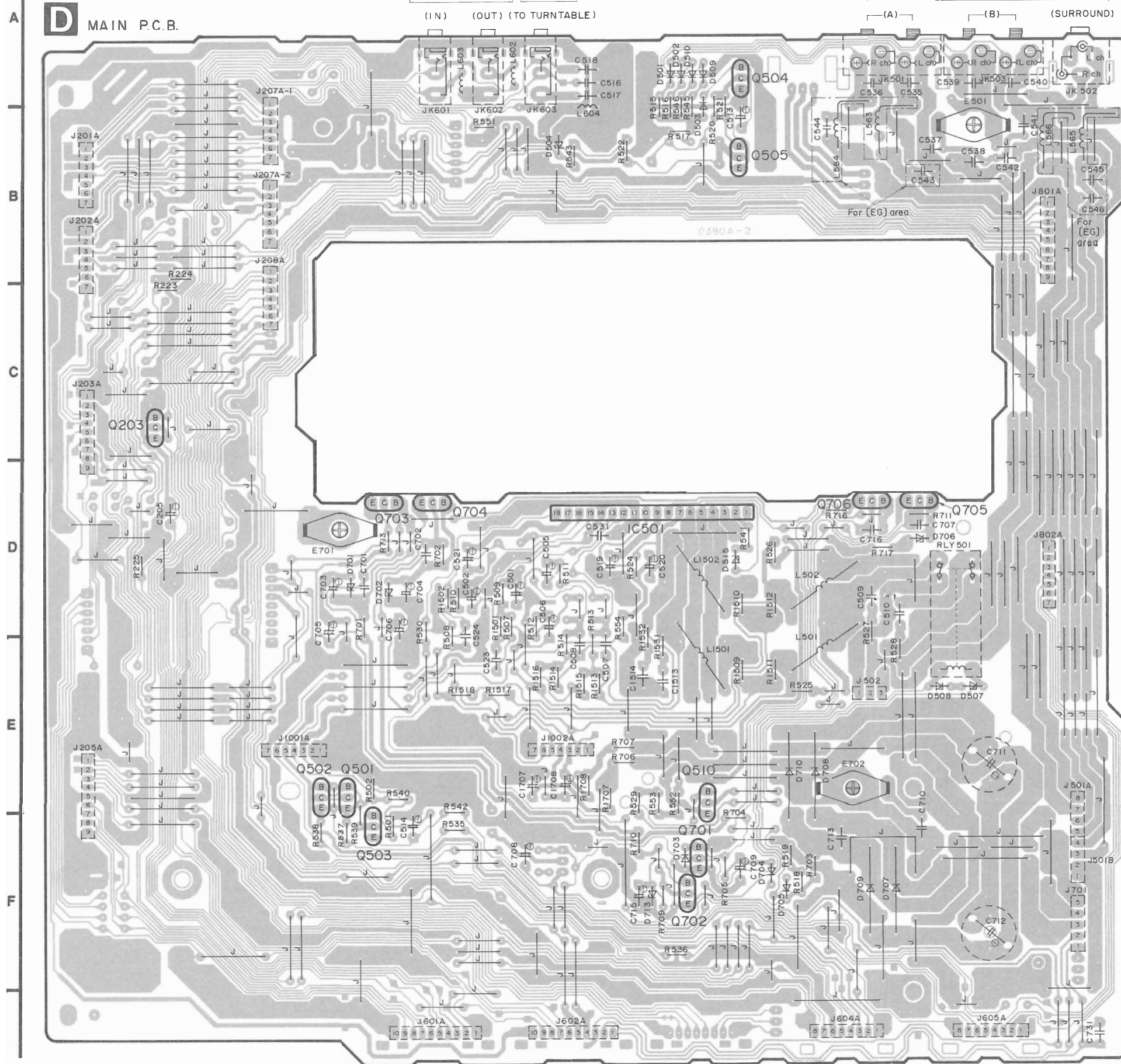

H V. CONTROL AMP P.C.B.

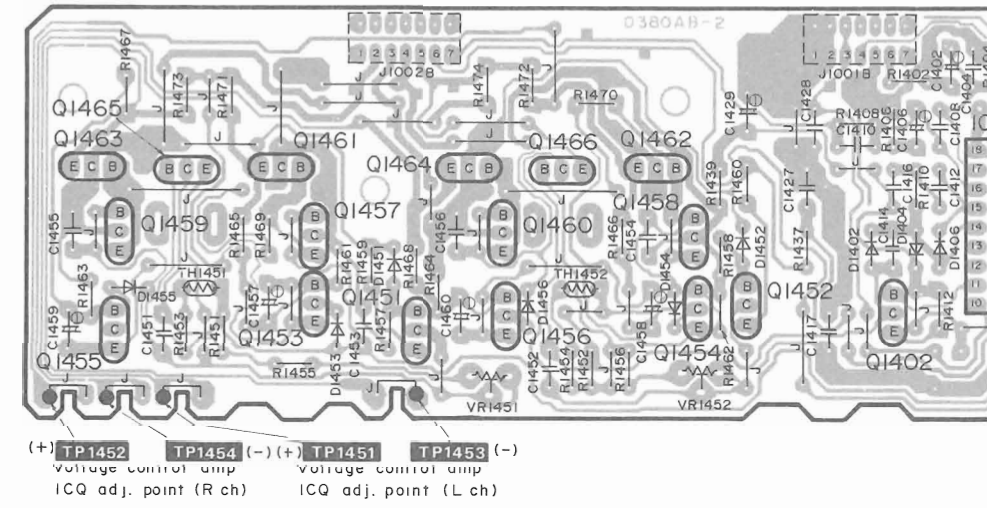

G OPERATION SWITCH P.C.B.

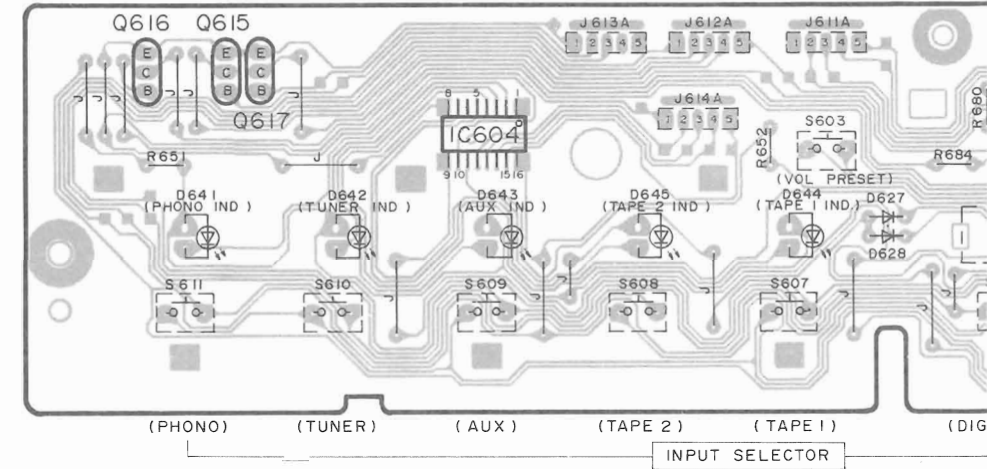

B PHONO/TAPE/TUNER/CD TERMINAL P.C.B.

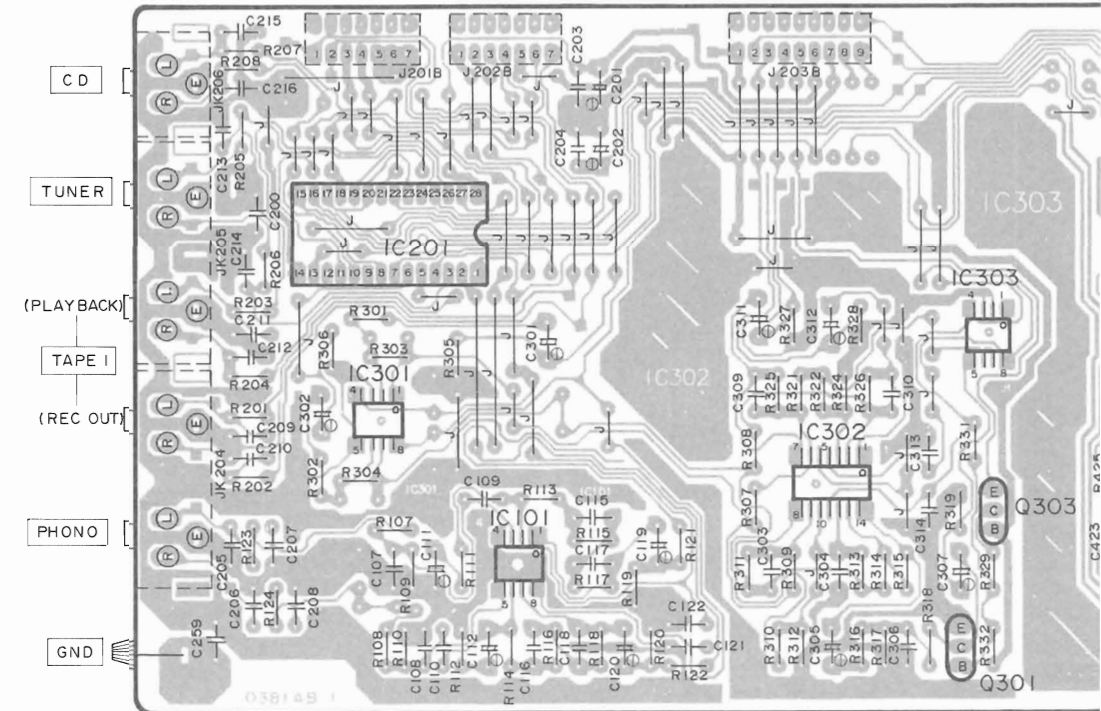

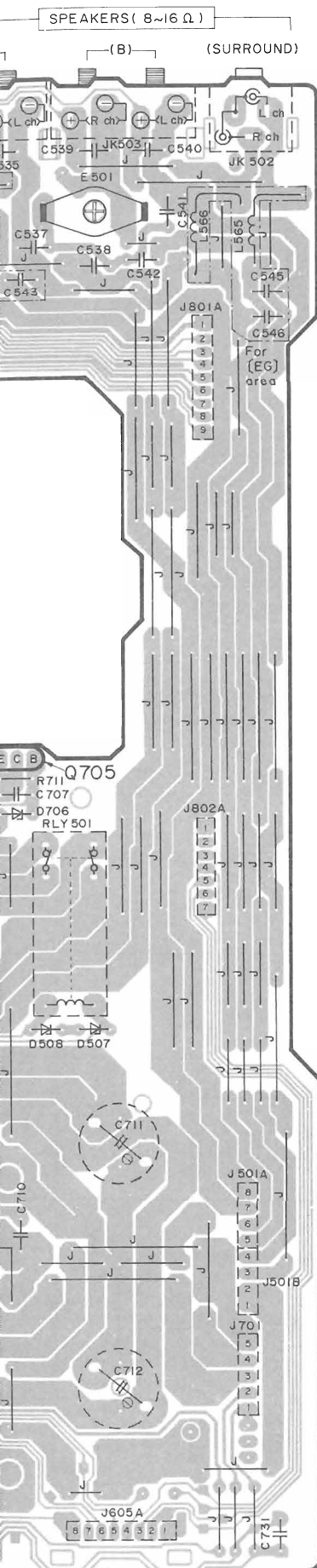

H V. CONTROL AMP P.C.B.

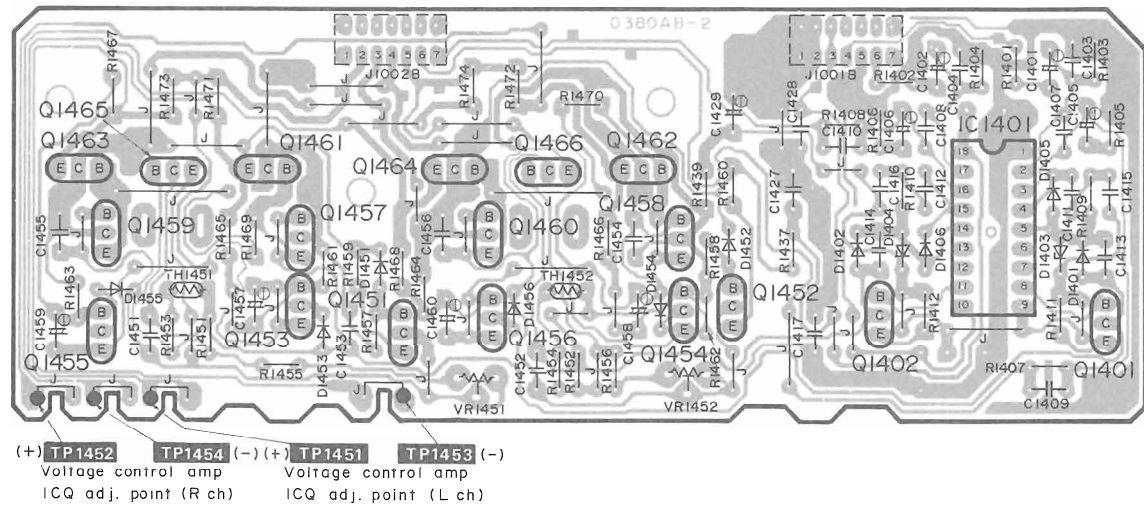

F VOLUME P.C.B.

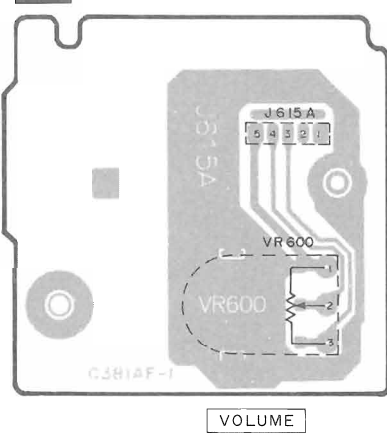

G OPERATION SWITCH P.C.B.

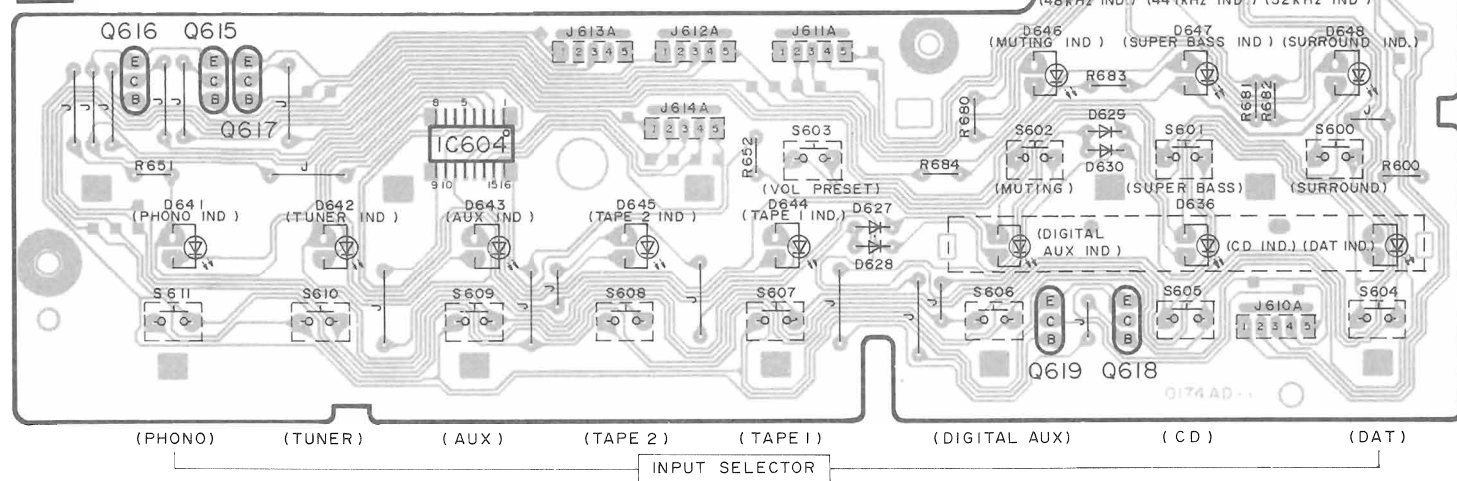

B PHONO/TAPE/TUNER/CD TERMINAL P.C.B.

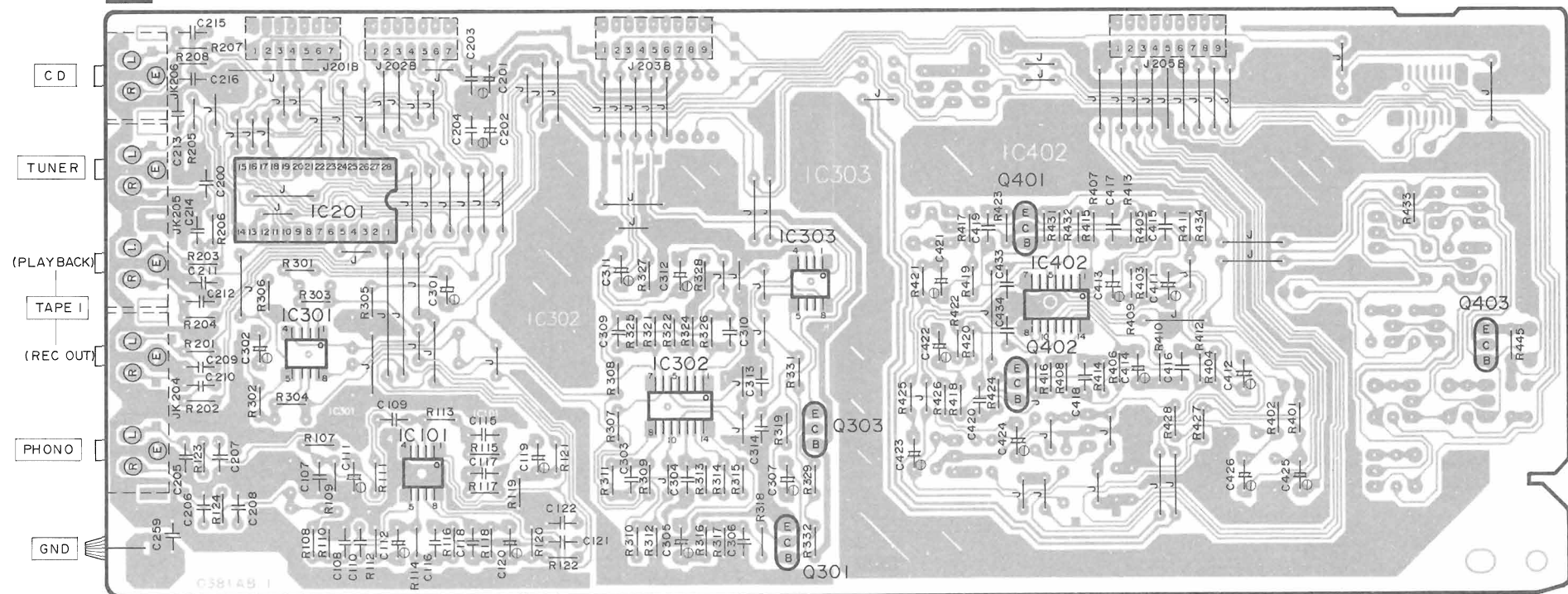

I POWER SWITCH/HEADPHONES P.C.B.

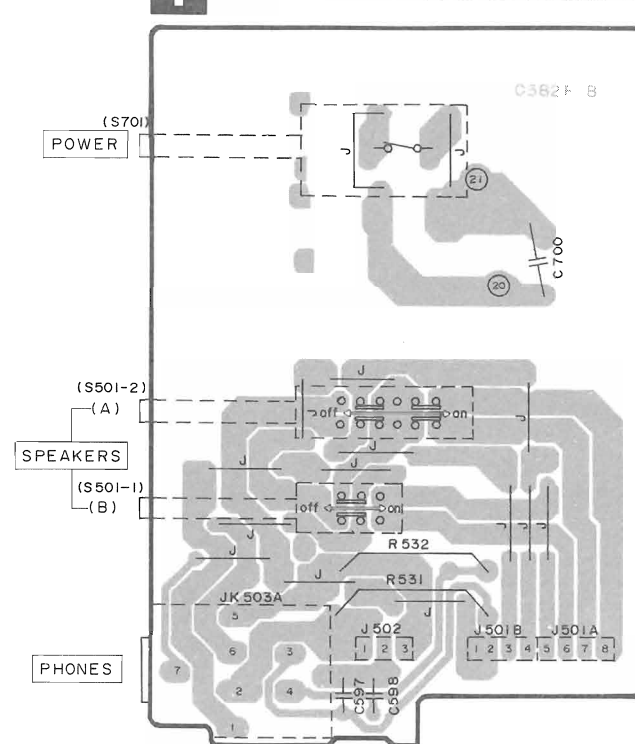

C INPUT/OUTPUT TER

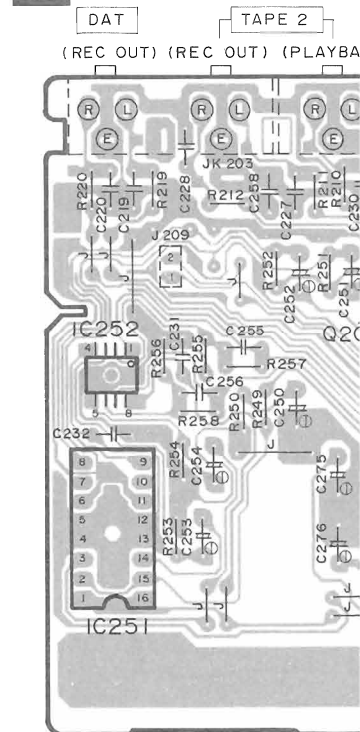

E FL DRIVE P.C.B.

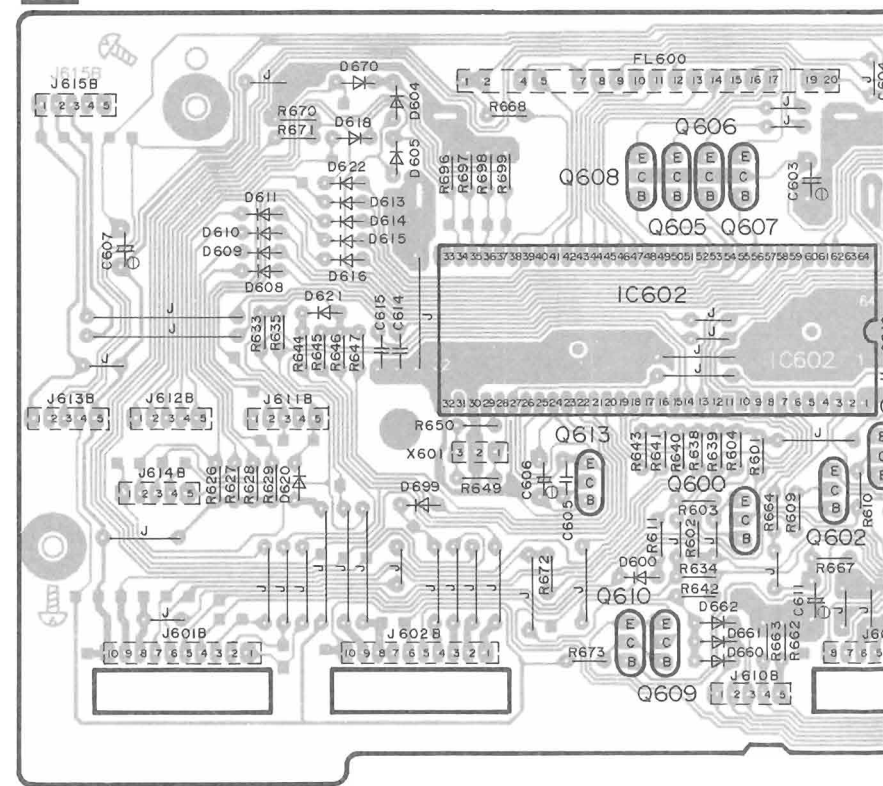

VOLUME P.C.B.

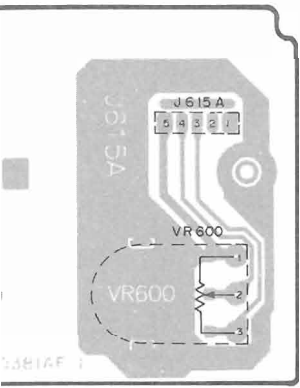

VOLUME

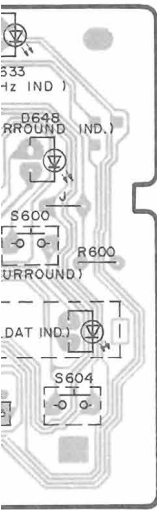

(DAT)

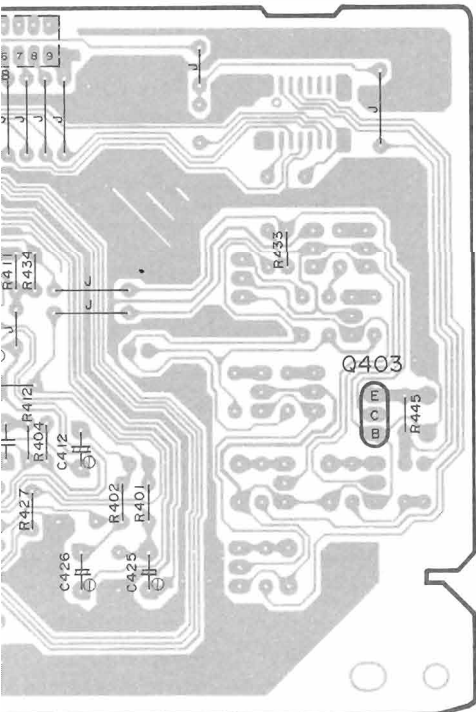

POWER SWITCH/HEADPHONES P.C.B.

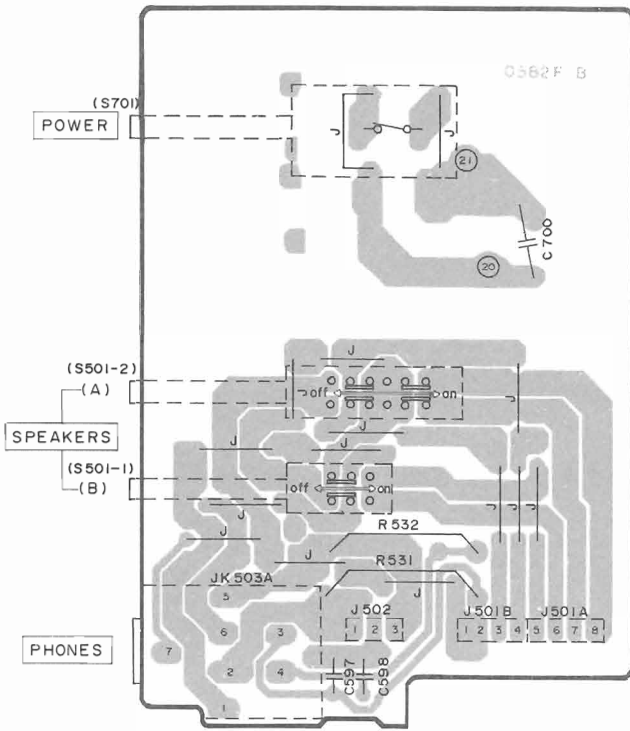

SPEAKERS

PHONES

INPUT/OUTPUT TERMINAL P.C.B.

(DAT) (TAPE 2) (AUX) (EXT) (REC OUT) (REC OUT) (PLAYBACK) (OUTPUT) (INPUT)

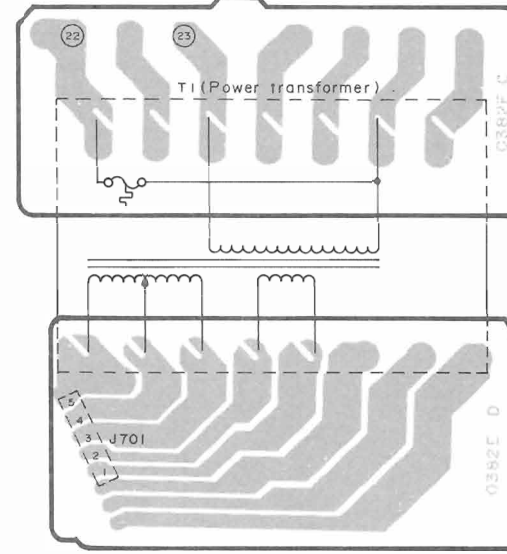
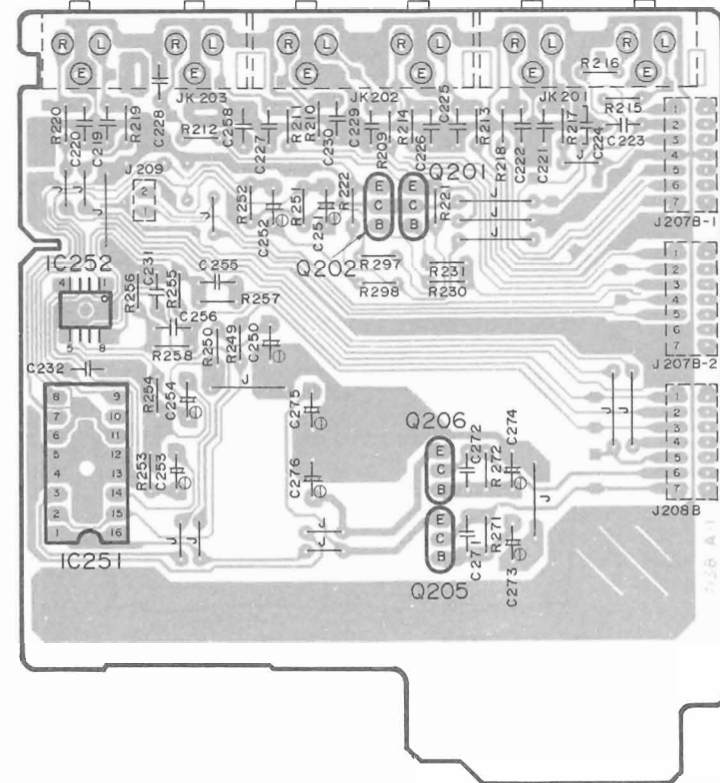

AC IN/AC OUTLET P.C.B.

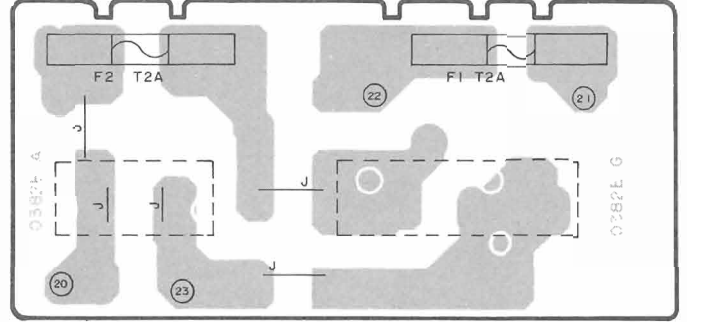

AC IN (220V (E, EG) 240V (EB) 50/60Hz)

AC OUTLET (UNSWITCHED)

D/A CONVERTER P.C.B.

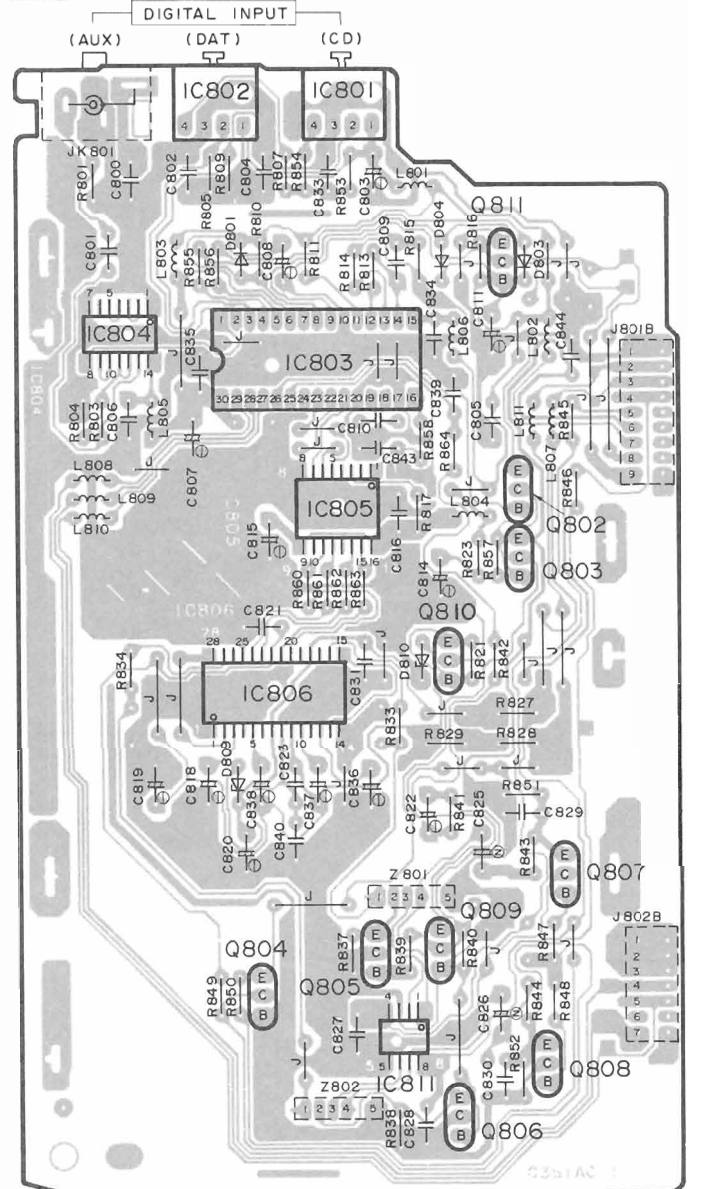

FL DRIVE P.C.B.

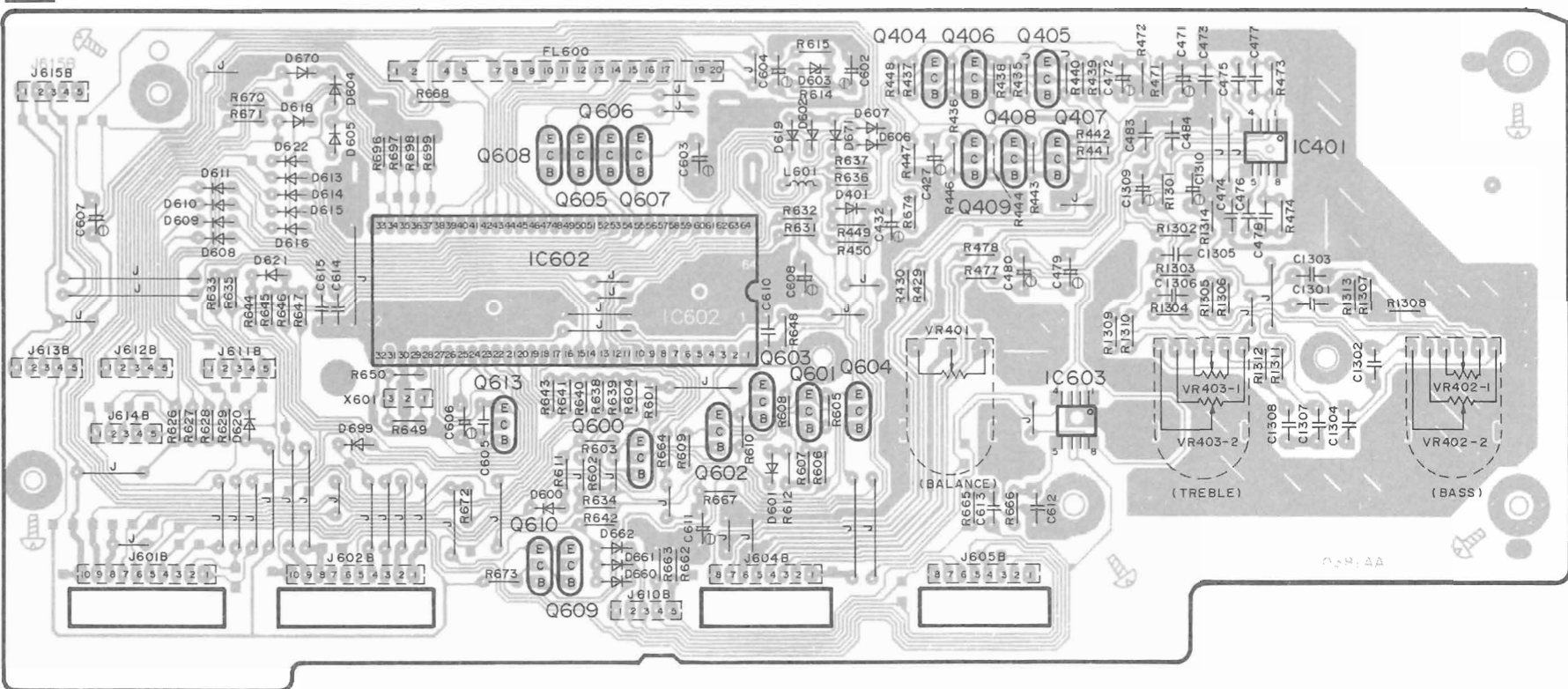

■ TERMINAL GUIDE OF IC'S, TRANSISTORS AND DIODES

<p>BA4560FT1</p>	<p>AN6558SFE2 BA4560FT1 LM833M63</p>	<p>AN6554NSFE2 MC74HCU04FEL</p>	<p>DN74LS145SE2 PD00601</p>
<p>PCM1700U-T1</p>	<p>M5283P</p>	<p>AN7062N</p>	<p>TC9164N</p>
<p>PD0052</p>	<p>M50754-128SP</p>	<p>SVI3205</p>	<p>2SA992EFPTA 2SA1123RSTTA 2SB621AQRSTA 2SC1567QRS 2SC2631RSTTA 2SC3114STUTA</p>
<p>2SA1535AQRS 2SB1187DEF 2SC3944AQRS 2SD1761DEF</p>	<p>2SC2458ABCTA 2SD2144STA DTA114ESTP DTC114ESTP DTC144ESTP</p>	<p>2SA1309AQSTA 2SC3311AQSTA 2SD1450RSTTA UN4115TA UN4215TA</p>	<p>ECB</p>
<p>MA4120MTA MA4150MTA MA4160MTA MA4300MTA</p>	<p>MA4036MTA MA4043MTA MA4047MTA MA4051MTA MA4062HTA</p>	<p>MA700ATA</p>	<p>MA165TA MA167TA MA29WATA 1SS291TA</p>
<p>LN032494PS</p>	<p>LN820RP-C</p>	<p>LN846RP-C</p>	<p>RVDP300DLF</p>

■ WIRING CONNECTION DIAGRAM

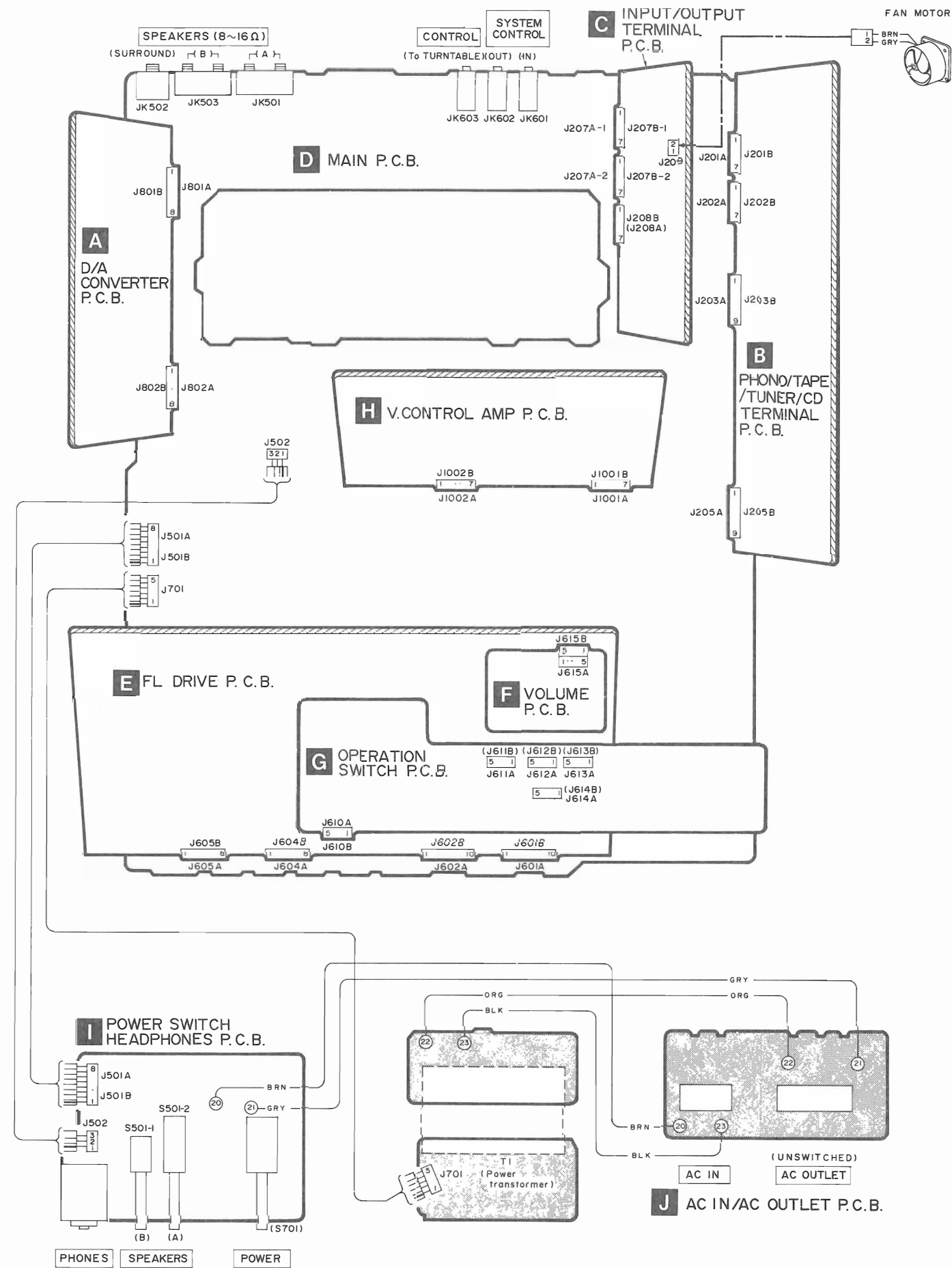

■ BLOCK DIAGRAM

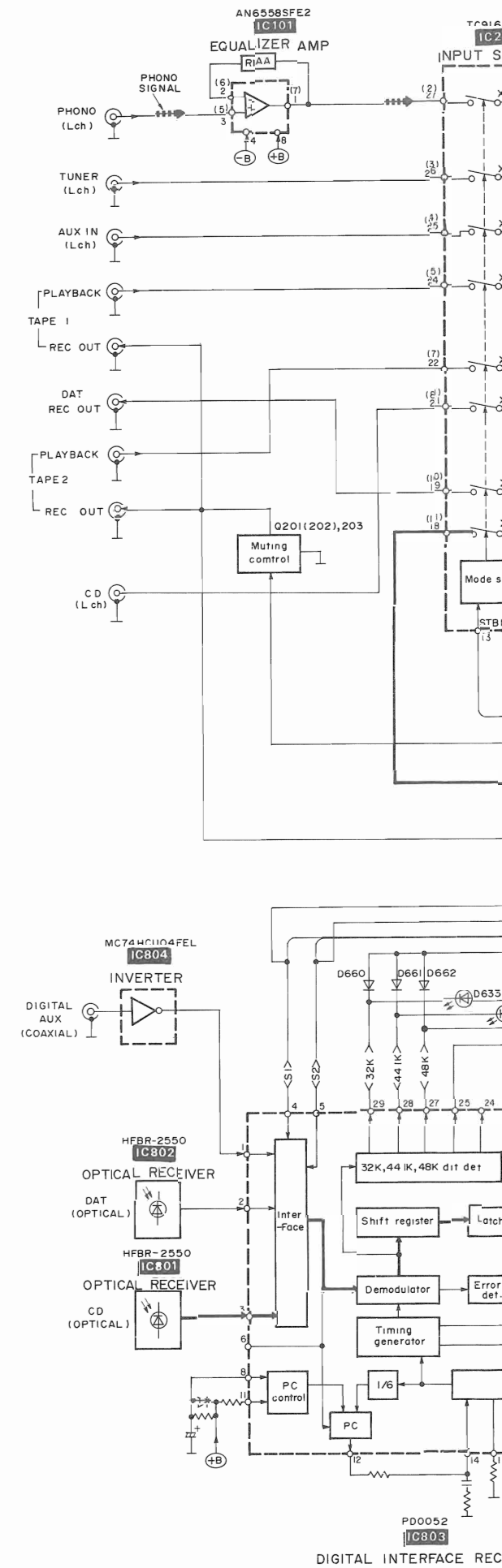

■ BLOCK DIAGRAM

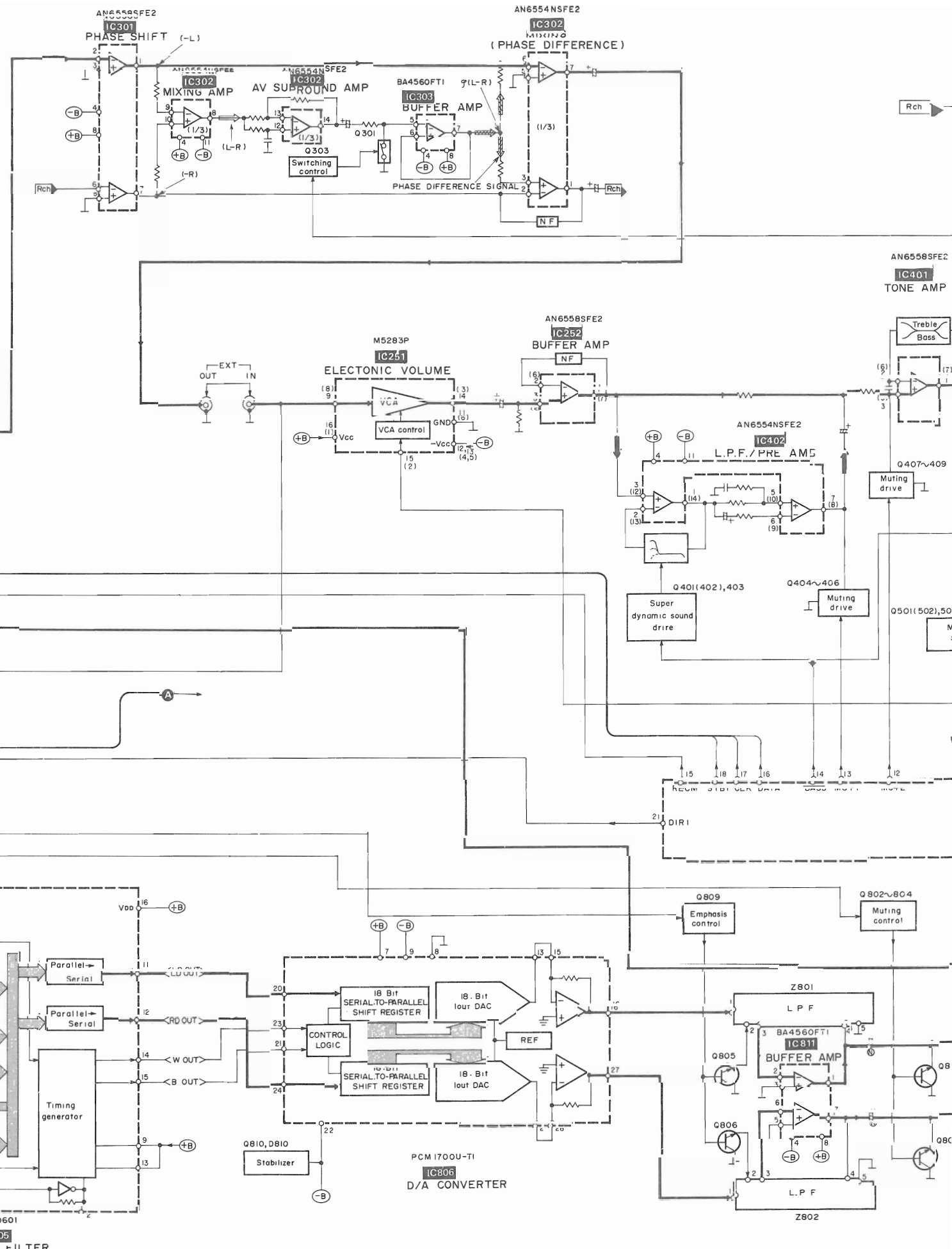
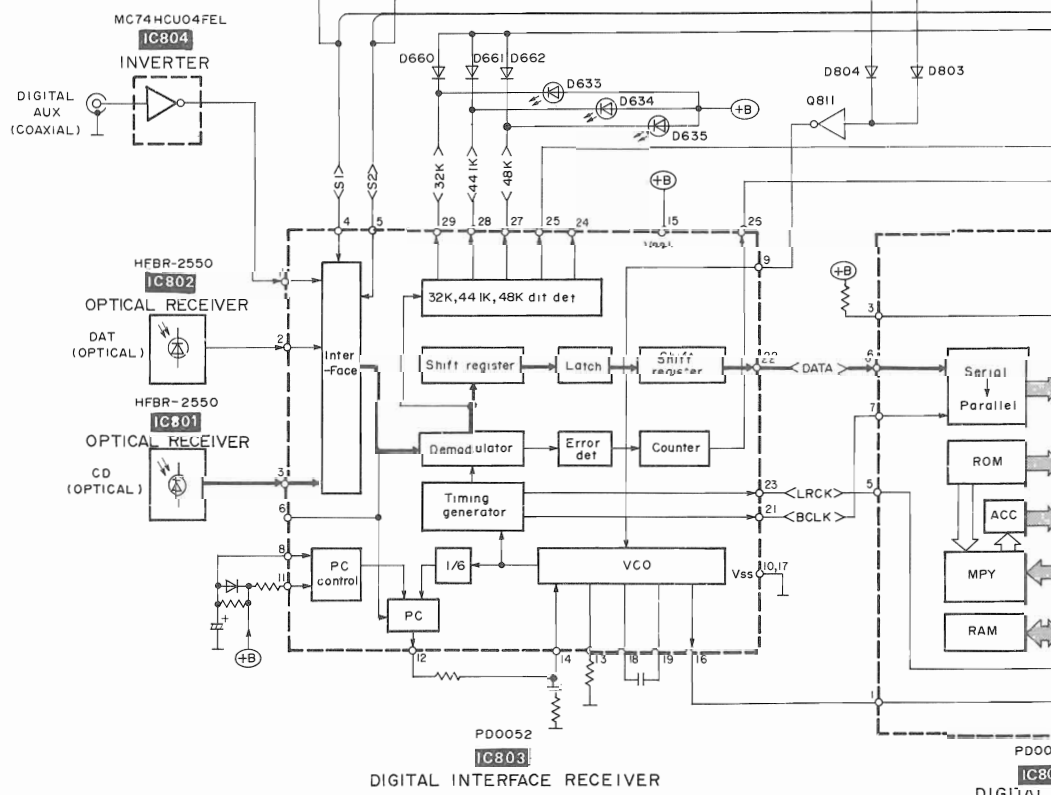
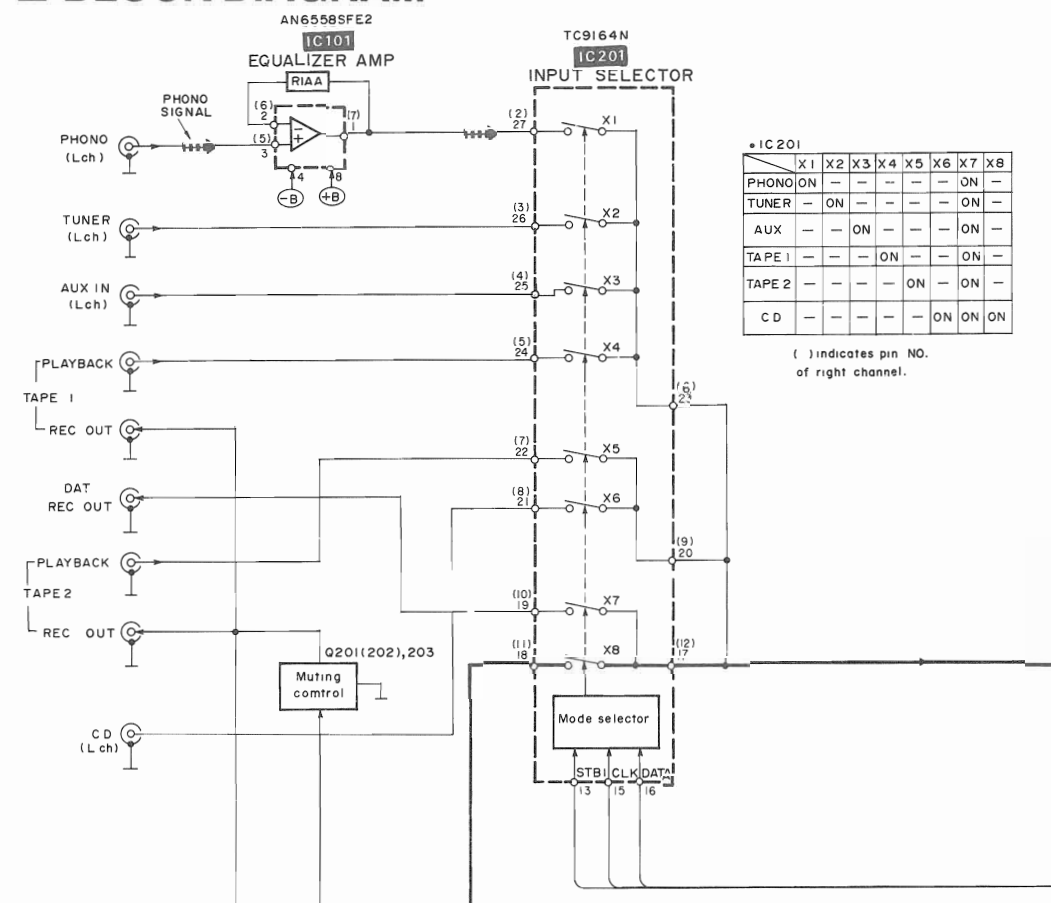
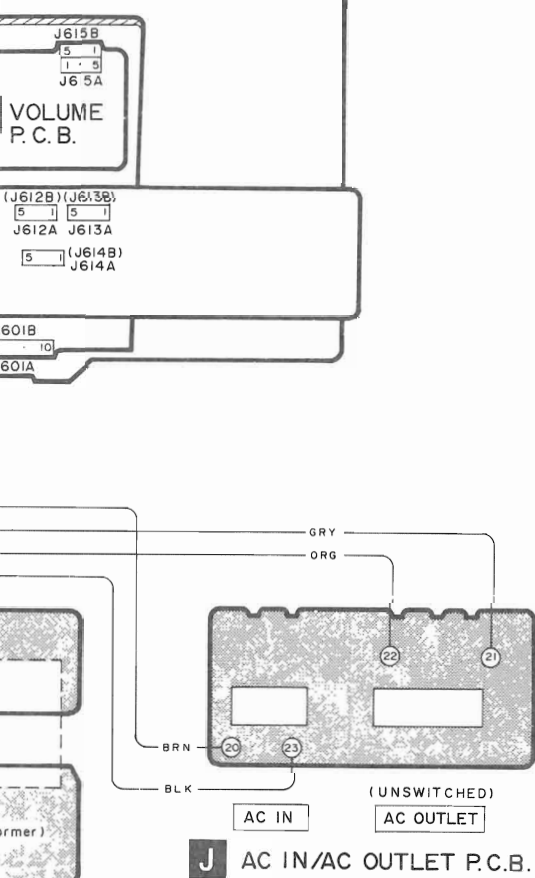
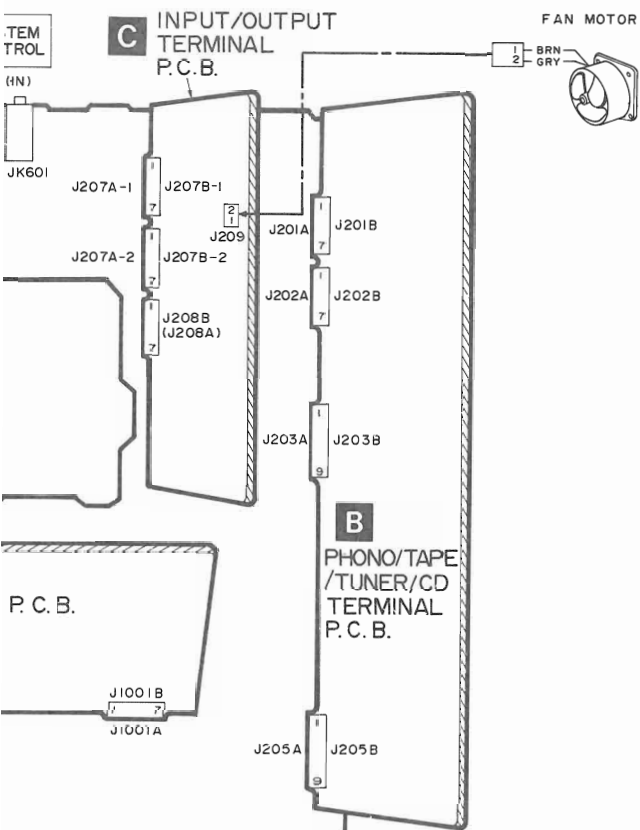

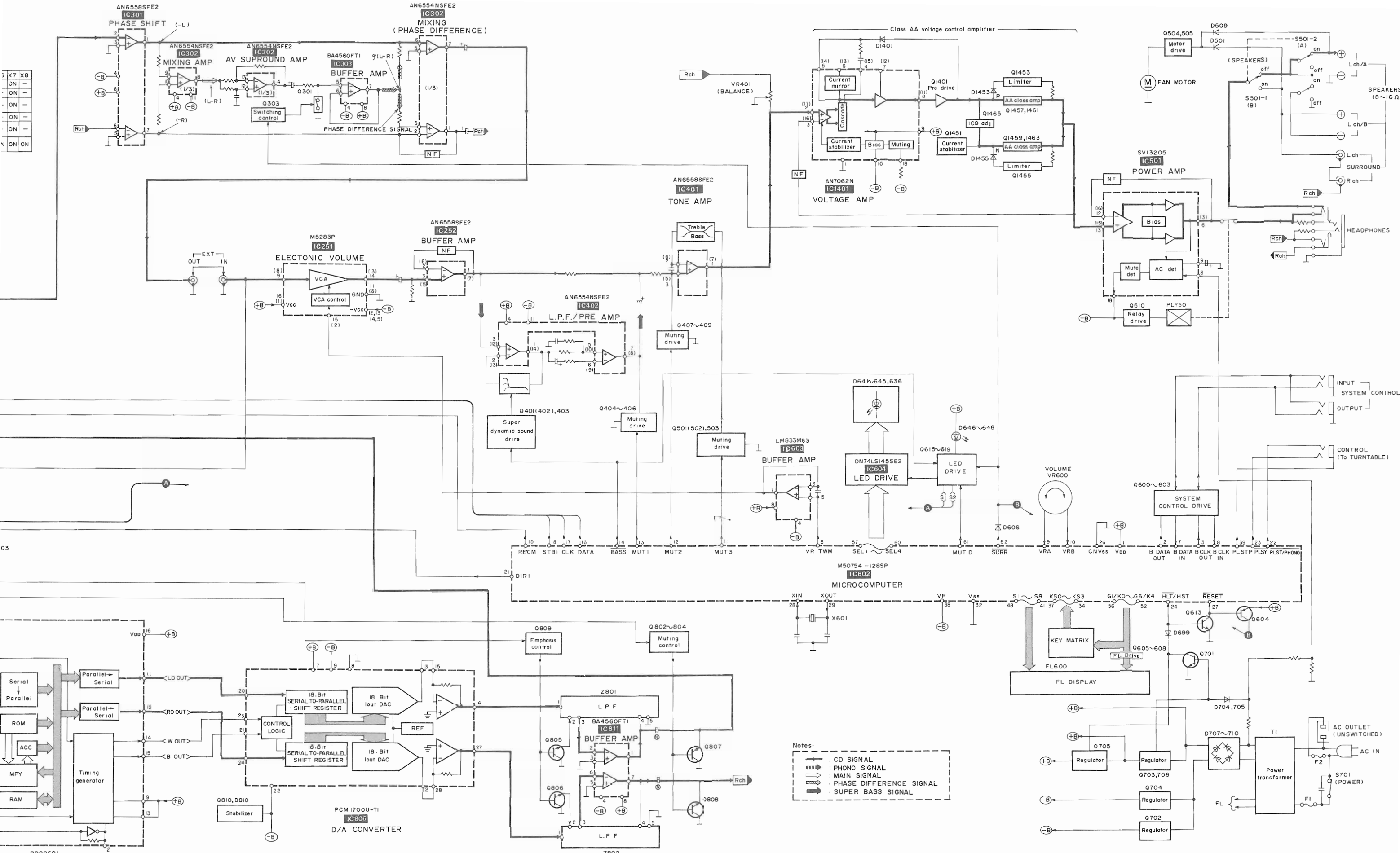

DESCRIPTION OF FL PANEL [FL600 (SADTV217)]

GRID ASSIGNMENT

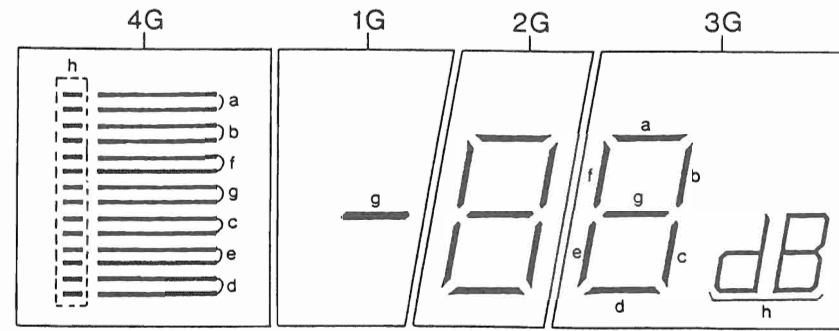

PIN CONNECTION

Pin No.	20	19	18	17	16	15	14	13	12	11	10	9	8	7	6	5	4	3	2	1
Connection	F2	F2	NP	a	4G	b	c	d	1G	e	f	2G	g	3G	NP	h	3G	NP	F1	F1

FUNCTIONS OF IC TERMINALS

IC805 (PD00601)

Pin No.	Symbol	I/O	Function Description											
1	X IN	I	These are the I/O terminals for the oscillating clock signal.											
2	X OUT	O												
3	MODE 1	I		Master clock input terminal.										
5	LR CLK	I	LR clock input terminal.											
6	DATA	I	Serial data input terminal.											
7	BCK	I	Bit clock input terminal.											
9 • 13	MODE 2 • MODE 3	I	Select the output data.											
			<table border="1"> <thead> <tr> <th>MODE 3</th> <th>MODE 2</th> <th>OUTPUT DATA</th> </tr> </thead> <tbody> <tr> <td rowspan="2">H</td> <td>H</td> <td>18 bit</td> </tr> <tr> <td>L</td> <td>16 bit</td> </tr> <tr> <td>L</td> <td>—</td> <td>20 bit</td> </tr> </tbody> </table>	MODE 3	MODE 2	OUTPUT DATA	H	H	18 bit	L	16 bit	L	—	20 bit
			MODE 3	MODE 2	OUTPUT DATA									
			H	H	18 bit									
L	16 bit													
L	—	20 bit												
11	LD OUT	O	Output the signal on the left channel.											
12	RD OUT	O	Output the signal on the right channel.											
14	W OUT	O	Output the signal for the word clock.											
15	B OUT	O	Output the signal for the bit clock.											
16	VDD	I	To be connected to a power supply. (+5 V)											

IC602 (M50754-128SP)

Pin No.	Symbol	I/O	Function Description
1	VDD	—	To be connected to a power supply. (+5 V)
2	B. DATA OUT	O	This is the output terminal for the bus data signal.
3	B. CLK OUT	O	This is the output terminal for the bus clock signal.
6	VR PWM	O	This terminal outputs the signal for the control of the volume.
7	B. DATA IN	I	This is the input terminal for the bus data signal.
8	B. CLK IN	I	This is the input terminal for the bus clock signal.
9	VR A	I	These are the terminals for the rotary encoder of the volume of VR600.
10	VR B		
11	MUT 3	O	Outputs the -6 dB signal for control of attenuated muting.
12	MUT 2		
13	MUT 1	O	Output the signal for the control of muting.
14	BASS	O	Output the signal for the control of super bass LED.
15	REC M	O	Output the signal for muting the VTR 1 recording.
16	DATA	O	These are output terminal for data and clock signals.
17	CLK		
18	STB 1	O	The serial data inputted into IC201 is latched by the STB pulse and the switch is set to ON according to data.
22	PLST/PHONO	O	These are the terminals for sync recording on the player.
23	PLSY	I	
24	HLT/HST	I	This is the terminal for the detection of power supply.
25	KS4	I	This is the key scan terminal.
27	RESET	I	This is the input terminal for the reset signal.
28	X IN	I	These are the I/O terminals for the oscillating clock signal.
29	X OUT	O	
34 } 37	KS 3 } KS 0	I	These are the key scan terminals.
38	VP	I	The signal which pulls down the voltage is inputted into this terminal.
39	PLS TP	O	This is the terminal for sync recording on the player.
41 } 48	S8 } S1	O	These terminals output signals for the control of the FL display.
52 } 56	G5/K4 } G1/K0		
57 } 60	SEL 1 } SEL 4		
61	MUT D	O	Output the signal for the control of the LED.
62	SURR		

REPLACEMENT PARTS LIST

Notes : * Important safety notice:
 Components identified by Δ mark have special characteristics important for safety. When replacing any of these components use only manufacturer's specified parts.
 * The parenthesized indications in the Remarks columns specify the areas. (Refer to the cover page for area.)
 Parts without these indications can be used for all areas.

Ref. No.	Part No.	Part Name & Description	Remarks	Ref. No.	Part No.	Part Name & Description	Remarks
		INTEGRATED CIRCUIT(S)		Q615	DTC114ESTP	TRANSISTOR	
IC101	AN6558SFE2	IC, PHONO EQ AMP.		Q616, 617	UN4215TA	TRANSISTOR	
IC201	TC9164N	IC, INPUT SELECTOR		Q618, 619	DTA114ESTP	TRANSISTOR	
IC251	M5283P	IC, ATTENUATOR		Q701	UN4215TA	TRANSISTOR	
IC252	AN6558SFE2	IC, BUFFER AMP.		Q702	2SB621AQRSTA	TRANSISTOR	
IC301	AN6558SFE2	IC, PHASE SHIFT		Q703	2SD1761DEF	TRANSISTOR	
IC302	AN6554NSFE2	IC, MIXING/PHASE SHIFT		Q704	2SB1187DEF	TRANSISTOR	
IC303	BA4560FT1	IC, BUFFER AMP.		Q705, 706	2SD1761DEF	TRANSISTOR	
IC401	AN6558SFE2	IC, TONE AMP.		Q802, 803	DTC114ESTP	TRANSISTOR	
IC402	AN6554NSFE2	IC, PRE/BUFFER AMP.		Q804	DTA114ESTP	TRANSISTOR	
IC501	SVI3205	IC, POWER AMP.		Q805, 806	2SC3114STUTA	TRANSISTOR	
IC602	M50754-128SP	IC, MICROCOMPUTER		Q807, 808	2SD2144STA	TRANSISTOR	
IC603	LM833M63	IC, BUFFER AMP.		Q809	DTA114ESTP	TRANSISTOR	
IC604	DN74LS145SE2	IC, LED DRIVE		Q810	2SC3311AQSTA	TRANSISTOR	
IC801, 802	HFBR-2550	IC, OPTICAL RECEIVER		Q811	DTC114ESTP	TRANSISTOR	
IC803	PD0052	IC, DIGITAL INTERFACE		Q1401, 1402	2SA1123-R	TRANSISTOR	
IC804	MC74HC04FEL	IC, INVERTER		Q1451, 1452	2SC2631-R	TRANSISTOR	
IC805	PD00601	IC, DIGITAL FILTER		Q1453, 1454	2SC3311AQSTA	TRANSISTOR	
IC806	PCM1700U-T1	IC, D/A CONVERTER		Q1455, 1456	2SA1309AQSTA	TRANSISTOR	
IC811	BA4560FT1	IC, BUFFER AMP.		Q1457, 1458	2SC2631-R	TRANSISTOR	
IC1401	AN7062N	IC, VOLTAGE AMP.		Q1459, 1460	2SA1123-R	TRANSISTOR	
		TRANSISTOR(S)		Q1461, 1462	2SC3944QRS	TRANSISTOR	
				Q1463, 1464	2SA1535AQRS	TRANSISTOR	
				Q1465, 1466	2SC1567QRS	TRANSISTOR	
						DIODE (S)	
Q201, 202	2SD2144STA	TRANSISTOR		D401	MA165TA	DIODE	
Q203	DTA114ESTP	TRANSISTOR		D501, 502	MA167TA	DIODE	
Q205	2SC3311AQSTA	TRANSISTOR		D503	MA165TA	DIODE	
Q206	2SA1309AQSTA	TRANSISTOR		D504	MA4051MTA	DIODE	
Q301	2SD2144STA	TRANSISTOR		D507, 508	MA4120MTA	DIODE	
Q303	DTA114ESTP	TRANSISTOR		D509, 510	MA167TA	DIODE	
Q401, 402	2SD2144STA	TRANSISTOR		D515	MA4160MTA	DIODE	
Q403, 404	DTA114ESTP	TRANSISTOR		D600, 601	MA700ATA	DIODE	
Q405-408	2SD2144STA	TRANSISTOR		D602	MA165TA	DIODE	
Q409	2SA1309AQSTA	TRANSISTOR		D603	MA4047MTA	DIODE	
Q501, 502	2SD1450RSTTA	TRANSISTOR		D604-611	MA165TA	DIODE	
Q503	2SA1309AQSTA	TRANSISTOR		D613-616	MA165TA	DIODE	
Q504	2SC2458ABCTA	TRANSISTOR		D618	MA165TA	DIODE	
Q505	2SA1309AQSTA	TRANSISTOR		D619	1SS291TA	DIODE	
Q510	2SA992EFPTA	TRANSISTOR		D620, 621	MA165TA	DIODE	
Q600, 601	2SC3311AQSTA	TRANSISTOR		D622	MA700ATA	DIODE	
Q602, 603	DTC114ESTP	TRANSISTOR		D627-630	MA165TA	DIODE	
Q604	UN4115TA	TRANSISTOR		D633-635	LN846RP-C	LED	
Q605-608	DTC114ESTP	TRANSISTOR		D636	LN038494PS	LED	
Q609, 610	2SC3311AQSTA	TRANSISTOR		D641-645	LN820RP-C	LED	
Q613	DTC114ESTP	TRANSISTOR					

Ref. No.	Part No.	Part Name & Description	Remarks	Ref. No.	Part No.	Part Name & Description	Remarks
D646-648	LN846RP-C	LED		L1501, 1502	SLQY18G-10	COIL	
D660-662	MA165TA	DIODE				OSCILLATOR(S)	
D670, 671	MA165TA	DIODE					
D699	MA165TA	DIODE		X601	EFOGC6004T4	OSCILLATOR	
D701, 702	MA4150MTA	DIODE				DISPLAY TUBE	
D703	MA165TA	DIODE					
D704, 705	MA167TA	DIODE		FL600	SADFV217	DISPLAY TUBE	
D706	MA4062HTA	DIODE				FUSE (S)	
D707-710	RVDP300DLF	DIODE	Δ	F1, 2	XBA2C20TB0	FUSE 250V T2.0A	Δ
D713	MA4300MTA	DIODE				SWITCH(ES)	
D801	MA165TA	DIODE		S501-1	SSH2128	SW, SP SELECTOR B	
D803, 804	MA165TA	DIODE		S501-2	SSH2128	SW, SP SELECTOR A	
D809	MA4051LTA	DIODE		S600	EVQ21405R	SW, SURROUND SOUND	
D810	MA4043MTA	DIODE		S601	EVQ21405R	SW, SUPER BASS	
D1401, 1402	MA167ATA	DIODE		S602	EVQ21405R	SW, AUDIO MUTING	
D1403, 1404	MA4036MTA	DIODE		S603	EVQ21405R	SW, VOLUME PRESET	
D1405, 1406	MA165TA	DIODE		S604	EVQ21405R	SW, INPUT SELECTOR (DAT)	
D1451, 1452	MA29WATA	DIODE		S605	EVQ21405R	SW, INPUT SELECTOR (CD)	
D1453-1456	MA165TA	DIODE		S606	EVQ21405R	SW, INPUT SELECTOR (D. AUX)	
		VARIABLE RESISTOR(S)		S607	EVQ21405R	SW, INPUT SELECTOR (TAPE1)	
VR401	EWHFDAF25G15	BALANCE CONTROL		S608	EVQ21405R	SW, INPUT SELECTOR (TAPE2)	
VR402, 403	EW2XAF25C15	BASS/TREBLE CONTROL		S609	EVQ21405R	SW, INPUT SELECTOR (AUX)	
VR600	EVQWVVF2024B	MAIN VOLUME		S610	EVQ21405R	SW, INPUT SELECTOR (TUNER)	
VR1451	EVNDCAA03B52	IDLING (ICQ) ADJUSTMENT		S611	EVQ21405R	SW, INPUT SELECTOR (PHONO)	
VR1452	EVNDCAA03B52	IDLING (ICQ) ADJUSTMENT		S701	ESB8249V	SW, POWER	Δ
		THERMISTOR(S)				JACK(S)	
TH1451	ERTD2ZHL104T	THERMISTOR					
TH1452	ERTD2ZHL104T	THERMISTOR					
		COMPONENT COMBINATION(S)		J209	SJT3213	CONNECTOR (2P)	
Z801, 802	H8DN2041B	COMPONENT COMBINATION		J502	RJS1A1703	CONNECTOR (3P)	
		COIL(S)		J701	RJS1A1705	CONNECTOR (5P)	
L501, 502	SLQY18G-10	COIL		J201A	RJT057W007	CONNECTOR (7P)	
L563-566	SLQY07G-40	COIL	(EG)	J202A	RJT057W007	CONNECTOR (7P)	
L601	RLQZP100KT-Y	COIL		J203A	RJT057W009	CONNECTOR (9P)	
L602-604	RLQZP101KT-Y	COIL		J205A	RJT057W009	CONNECTOR (9P)	
L801	RLQZP470KT-Y	COIL		J208A	RJT057W007	CONNECTOR (7P)	
L802	RLQZP101KT-Y	COIL		J501A	RJS1A1704	CONNECTOR (4P)	
L803	RLQZP3R3KT-Y	COIL		J601A	RJU003K010M1	SOCKET (10P)	(Black)
L804	RLQZP1R2KT-Y	COIL			SJT31054WF	CONNECTOR (10P)	(Ivory)
L805	RLQZP3R3KT-Y	COIL		J602A	RJU003K010M1	SOCKET (10P)	(Black)
L806	RLQZP1R2KT-Y	COIL			SJT31054WF	CONNECTOR (10P)	(Ivory)
L807	RLQZP3R3KT-Y	COIL		J604A	RJU003K008M1	SOCKET (8P)	(Black)
L808-810	RLQZP1R2KT-Y	COIL			SJT30854WF	CONNECTOR (8P)	(Ivory)
L811	RLQZP3R3KT-Y	COIL		J605A	RJU003K008M1	SOCKET (8P)	(Black)
					SJT30854WF	CONNECTOR (8P)	(Ivory)
				J610A	SJS50581BB	SOCKET (5P)	

Ref. No.	Part No.	Part Name & Description	Remarks	Ref. No.	Part No.	Part Name & Description	Remarks
J611A	SJS50581BB	SOCKET (5P)		J801B	RJU057W009	SOCKET (9P)	
J612A	SJS50581BB	SOCKET (5P)		J802B	RJU057W007	SOCKET (7P)	
J613A	SJS50581BB	SOCKET (5P)		J1001B	RJU057W007	SOCKET (7P)	
J614A	SJS50581BB	SOCKET (5P)		J1002B	RJU057W007	SOCKET (7P)	
J615A	SJS50581BB	SOCKET (5P)		JK201	SJF3069N	EXT IN/OUT	
J801A	RJT057W009	CONNECTOR (9P)		JK202	SJF3069N	TAPE2 PB/AUX	
J802A	RJT057W007	CONNECTOR (7P)		JK203	SJF3069N	DAT/TAPE2 REC OUT	
J1001A	RJT057W007	CONNECTOR (7P)		JK204	SJF3067N	PHONO/TAPE1 REC OUT	
J1002A	RJT057W007	CONNECTOR (7P)		JK205	SJF3069N	TAPE1 PB/TUNER	
J207A-1, 2	RJT057W007	CONNECTOR (7P)		JK206	SJF3068N	CD	
J207B-1, 2	RJU057W007	SOCKET (7P)		JK501	RJR0054	SP A	
J201B	RJU057W007	SOCKET (7P)		JK502	SJF3068-4N	SP SURROUND	
J202B	RJU057W007	SOCKET (7P)		JK503	RJR0054	SP B	
J203B	RJU057W009	SOCKET (9P)		JK503A	RJJ67TS02	H P JACK	
J205B	RJU057W009	SOCKET (9P)		JK601	RJJ33T01	SYSTEM CONTROL IN	
J208B	RJU057W007	SOCKET (7P)		JK602	RJJ33T01	SYSTEM CONTROL OUT	
J501B	RJS1A1704	CONNECTOR (4P)		JK603	RJJ33T01	TURN TABLE CONTROL	
J601B	RJT003K010M1	CONNECTOR (10P)	(Black or Gray)	JK801	SJFD7-2	DIGITAL INPUT	
	SJS51087WF	SOCKET (10P)	(Ivory)			FUSE HOLDER(S)	
J602B	RJT003K010M1	CONNECTOR (10P)	(Black or Gray)				
	SJS51087WF	SOCKET (10P)	(Ivory)				
J604B	RJT003K008M1	CONNECTOR (8P)	(Black or Gray)	FC1-4	SJT388	FUSE HOLDER	
	SJS50887WF	SOCKET (8P)	(Ivory)				
J605B	RJT003K008M1	CONNECTOR (8P)	(Black or Gray)			RELAY	
	SJS50887WF	SOCKET (8P)	(Ivory)				
J610B	SJT30549BB1	CONNECTOR (5P)		RLY501	SSY134	RELAY	
J611B	SJT30549BB1	CONNECTOR (5P)					
J612B	SJT30549BB1	CONNECTOR (5P)				TRANSFORMER(S)	
J613B	SJT30549BB1	CONNECTOR (5P)					
J614B	SJT30549BB1	CONNECTOR (5P)		T1	SLT5P289-W	POWER TRANSFORMER	△ (E, EG)
J615B	SJT30549BB1	CONNECTOR (5P)		T1	SLT5P288-W	POWER TRANSFORMER	△ (EB)

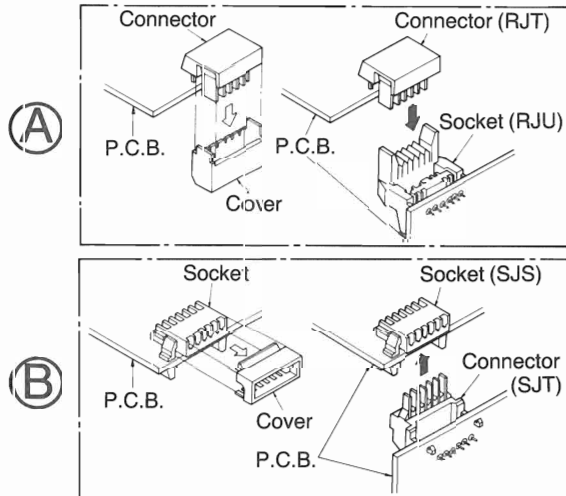

Pins	Part No.	
8 pin	RJT003K008M1	(Black or Gray)
8 pin	RJU003K008M1	(Black)
10 pin	RJT003K010M1	(Black or Gray)
10 pin	RJU003K010M1	(Black)

Pins	Part No.	
8 pin	SJS50887WF	(Ivory)
8 pin	SJT30854WF	(Ivory)
10 pin	SJS51087WF	(Ivory)
10 pin	SJT31054WF	(Ivory)

Notes:

- Regarding Ref. No. J601A, J602A, J604A, J605A, J601B, J602B, J604B, J605B, there are two types (A) and (B).
- Be sure to order the replacement parts of the desired color by the corresponding part numbers.
- The type-(A) connector and the type-(B) socket are protected with covers when they are supplied. Remove the cover after soldering the connector or socket to P.C.B.

Ref. No.	Part No.	Part Name & Description	Remarks	Ref. No.	Part No.	Part Name & Description	Remarks
		CABINET PARTS				PACKING MATERIAL	
1	RKMD024A-2K	CABINET		P1	RPG0469	CARTON BOX	
2	RHD30007	SCREW		P2	RPN0332	PAD	
3	SJP9205-2Y	SHORTING PIN		P3	SPSD152	ACCESSORIES BOX	
4	XTBS3+8JFZ1	SCREW		P4	XZB52X60A01Z	PROTECTION COVER	
5	RGR0083B-A	REAR PANEL	(E)				
5	RGR0083A-A	REAR PANEL	(EB)			ACCESSORIES	
5	RGR0083B-B	REAR PANEL	(EG)				
6	RGU0030	POWER BUTTON		A1	RQF0574	INSTRUCTIONS MANUAL ASS'Y	(E)
7	RGU0101	SP SELECTOR BUTTON		A1	RQF0573	INSTRUCTIONS MANUAL ASS'Y	(EB)
8	RGW0028-1K	TONE KNOB		A1	RQF0575	INSTRUCTIONS MANUAL ASS'Y	(EG)
9	RGW0049	MAIN VOL. KNOB		A1-1	RQA0013	WARRANTY CARD	(E, EG)
10	RFKJUX301E-K	CHASSIS ASS'Y		A1-2	RQCB0169	SERVICENTOR LIST	
10-1	RKA0011	FOOT		A1-3	RFKSUX901E-K	INSTRUCTIONS MANUAL	(E)
12	RMA0138	ANGLE		A1-3	RQT0486-B	INSTRUCTIONS MANUAL	(EB)
13	SHE187-2	HOLDER		A1-3	RQT0470-D	INSTRUCTIONS MANUAL	(EG)
14	SJS9231-1B	AC INLET	△	A1-4	RQCS0009	CAUTION NOTE FOR FTZ	(EG)
15	SJS9333B	AC OUTLET	△ (E, EG)	A2	SFDAC05E03	AC CORD	△ (E, EG)
15	SJS9332B	AC OUTLET	△ (EB)	A2	SJA188	AC CORD	△ (EB)
16	SNE4021-1	NUT					
17	SUS894-1	SPRING					
18	SYE1128-3	FAN ASS'Y					
18-1	SHE232	FAN					
18-2	SUS271	SPRING					
18-3	SHE233	FAN CASE					
18-4	MDN-4RB4MRC	MOTOR					
18-5	SHE234	CAP					
20	XTBS26+8J	SCREW					
21	XTB3+16J	SCREW					
22	XTB3+20JFZ	SCREW					
23	XTWS3+8T	SCREW					
24	SMN2056	FL HOLDER (L)					
25	SMN2056-1	FL HOLDER (R)					
26	RFKGUX901E-K	FRONT PANEL					
27	RFKNUX901EK1	VOL PRESET BUTTON					
28	RFKNUX901EK2	SURROUND(etc) BUTTON					
30	RGL0080-X	PANEL LIGHT					
31	RGL0081-X	PANEL LIGHT					
32	RGL0082-X	PANEL LIGHT					
33	RGU0361-K	INPUT SELECTOR BUTTON					
34	RGU0362-K	DIGITAL SELECTOR BUTTON					
35	SJS9231A	AC INLET COVER	△				
36	SJS9333A	AC OUTLET COVER	△ (E, EG)				
36	SJS9332A	AC OUTLET COVER	△ (EB)				
37	RMN0072	ANGLE					
38	XTB3+8J	SCREW					
39	RFKNUX901EKA	CAP					
40	SHR415	LATCH					

EXPLODED VIEW

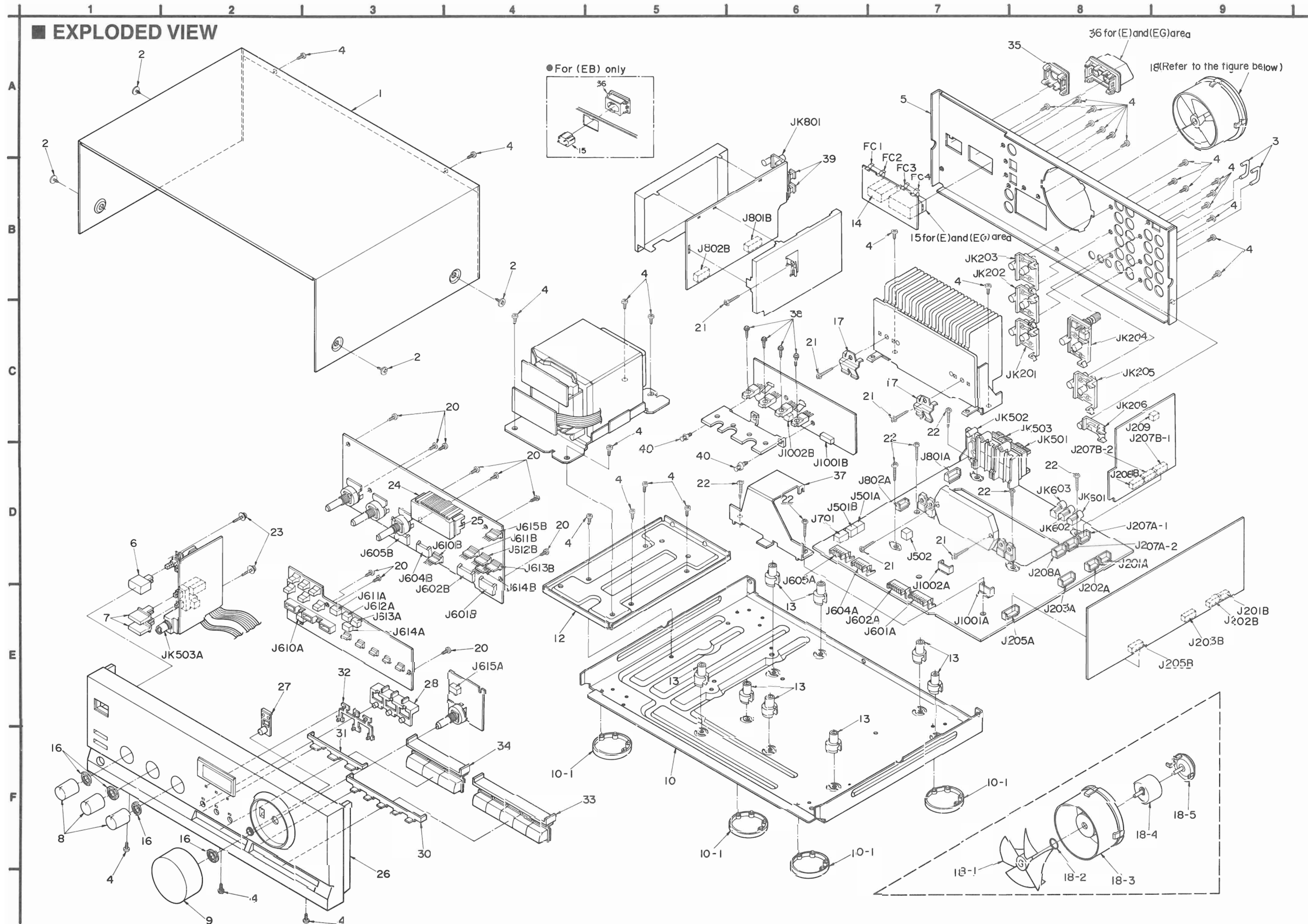

Ref. No.	Part No.	Values & Remarks	Ref. No.	Part No.	Values & Remarks			
C700	ECKWKC103PF2	400V 0.01U △	C1409, 1410	ECBT1H270J5	50V 27P			
C701, 702	ECKR1H103ZF5	50V 0.01U	C1411, 1412	ECBT1H681KB5	50V 680P			
C703, 704	ECEA1EU100B	25V 10U	C1413, 1414	ECCR2H070D5	500V 7P			
C705, 706	ECEA1CK100B	16V 10U	C1415-1417	ECBT1H102KB5	50V 1000P			
C707	ECBT1E103ZF5	25V 0.01U	C1427	ECKR1H223ZF5	50V 0.022U			
C708	ECEA1CK100B	16V 10U	C1428	ECBT1E223ZF5	25V 0.022U			
C709	ECEA1HK2R2B	50V 2.2U	C1429	ECEA1JU220B	63V 22U			
C710	ECBT1E223ZF5	25V 0.022U	C1451, 1452	ECKR1H333ZF5	50V 0.033U			
C711, 712	ECES1JU682U	63V 6800U	C1453-1456	ECCR2H680K5	500V 68P			
C713	ECQE2104KF3	250V 0.1U	C1457-1460	ECEA1HK010B	50V 1U			
C715	ECEA1VK100B	35V 10U	C1513, 1514	ECKR1H223ZF5	50V 0.022U			
C716	ECKR1H103ZF5	50V 0.01U	C1707, 1708	ECEA1JU220B	63V 22U			
C731	ECFR1E104ZF5	25V 0.1U						
C800, 801	ECBT1E223ZF5	25V 0.022U						
C802	ECFR1E104ZF5	25V 0.1U						
C803	ECEA1CK100B	16V 10U						
C804	ECFR1E104ZF5	25V 0.1U						
C805	ECBT1H102KB5	50V 1000P						
C806	ECFR1E104ZF5	25V 0.1U						
C807	ECEA1CK100B	16V 10U						
C808	ECEA1HK010B	50V 1U						
C809	ECQV1H104JZ3	50V 0.1U						
C810	ECBT1H220J5	50V 22P						
C811	ECEA0JK101B	6.3V 100U						
C814	ECEA0JK101B	6.3V 100U						
C815	ECEA1CK100B	16V 10U						
C816	ECBT1H102KB5	50V 1000P						
C818	ECEA1EK4R7B	25V 4.7U						
C819, 820	ECEA0JK101B	6.3V 100U						
C821	ECBT1E223ZF5	25V 0.022U						
C822	ECEA1EK100B	25V 10U						
C823	ECBT1H102KB5	50V 1000P						
C825, 826	ECEA1EN100SB	25V 10U						
C827, 828	ECBT1C103NS5	16V 0.01U						
C829, 830	ECBT1H102KB5	50V 1000P						
C831	ECBT1E223ZF5	25V 0.022U						
C833	ECQV1H104JZ3	50V 0.1U						
C834	ECBT1H102KB5	50V 1000P						
C835	ECBT1E223ZF5	25V 0.022U						
C836-838	ECEA1EK4R7B	25V 4.7U						
C839, 840	ECBT1H331KB5	50V 330P						
C843	ECBT1H220J5	50V 22P						
C844	ECBT1H102KB5	50V 1000P						
C1301, 1302	ECFR1E123KR	25V 0.012U						
C1303, 1304	ECFR1E683KR	25V 0.068U						
C1305, 1306	ECFR1E472KR	25V 4700P						
C1307, 1308	ECFR1E223KR	25V 0.022U						
C1309, 1310	ECEA1HPS010B	50V 1U						
C1401, 1402	ECEA1HPX3R3B	50V 3.3U						
C1403, 1404	ECBT1H680J5	50V 68P						
C1405, 1406	ECEA1CPX220B	16V 22U						
C1407, 1408	ECBT1H820KB5	50V 82P						

