

CONTROL / DISPLAY SCHEMATIC DIAGRAM - SCHEMA COMMANDES / AFFICHEUR - SCHALTBIL ESQUEMA MANDOS / INDICADOR

KDB

POWER

1: HAVE DIODE
0: NO DIODE VMAX

LOCATION	D726
2520	0
2521	1

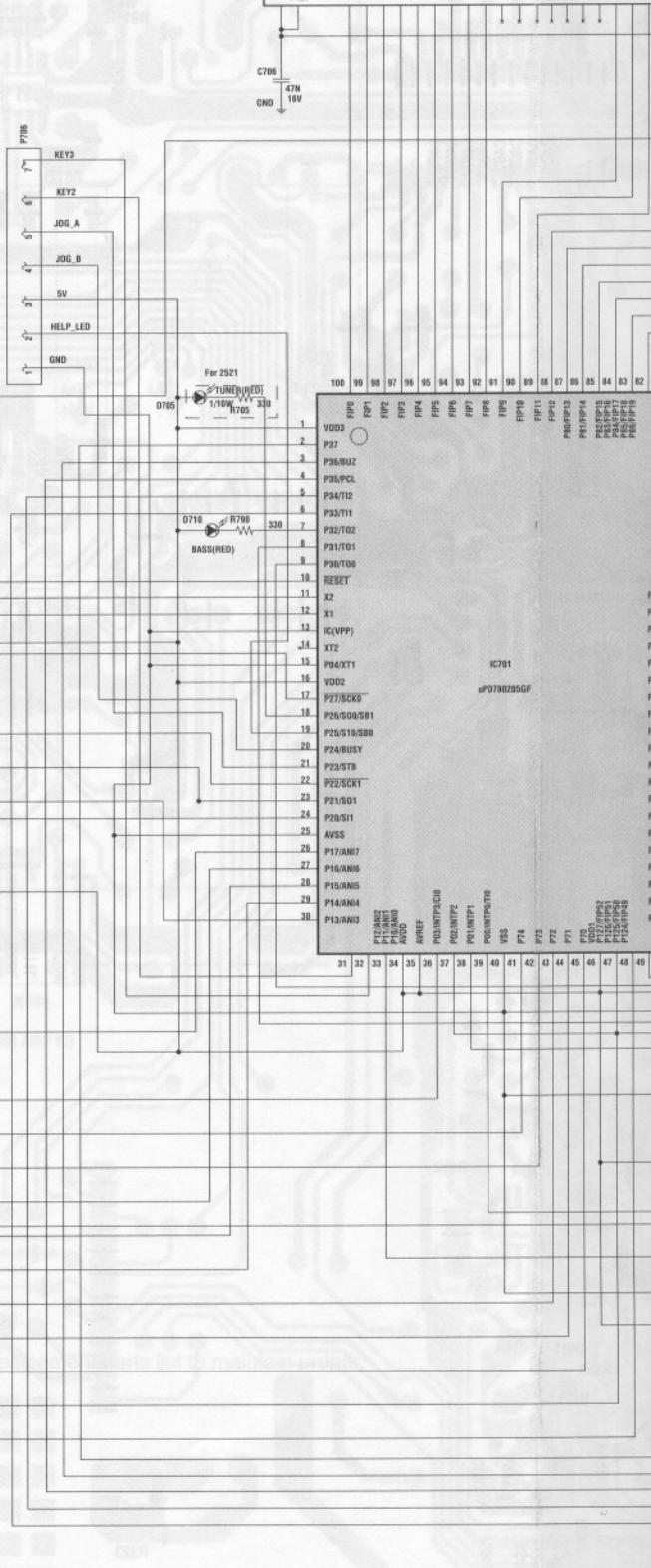
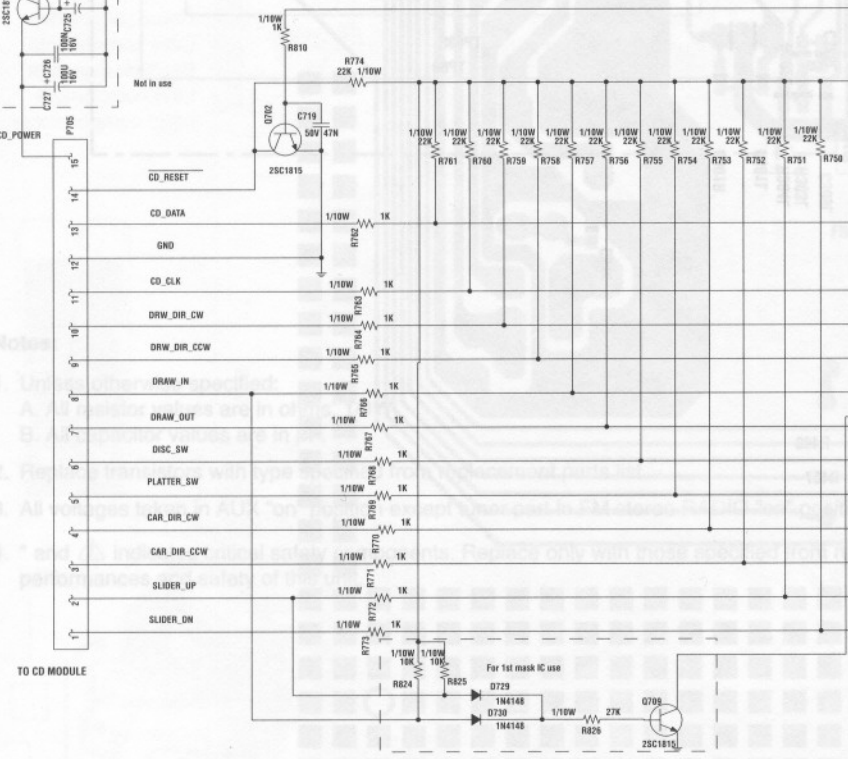
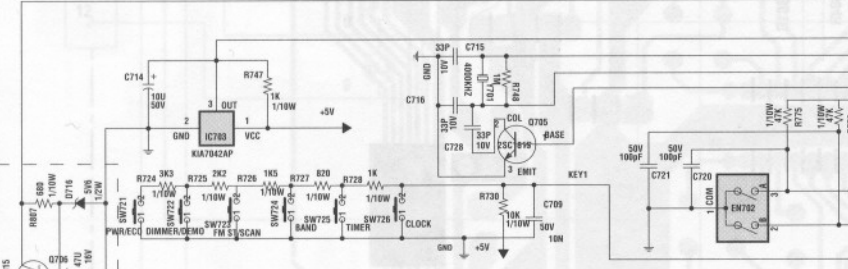
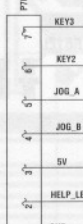
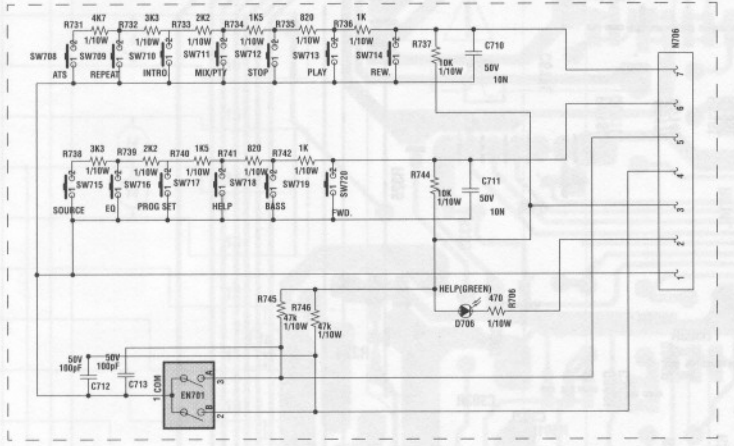
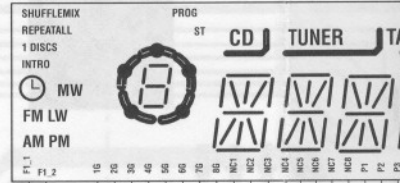

INDICATEUR - SCHALTBILD BEDIENTEIL / ANZEIGE - SCHEMA COMANDI / INDICATORE -

Main P.C.B.
Platine principale
Grundplatte
Placita principal

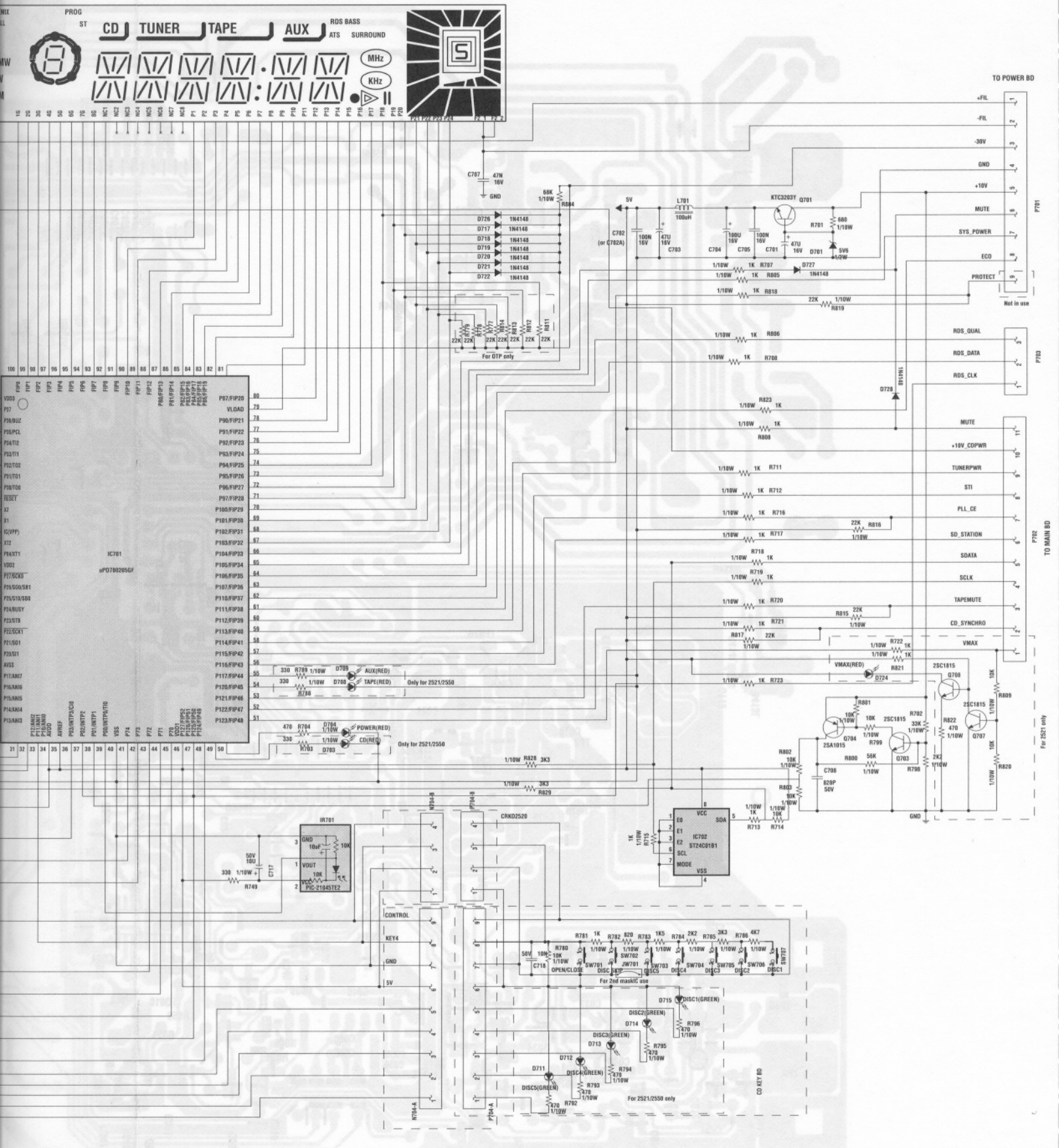

POWER SUPPLY SCHEMATIC DIAGRAM - ALIMENTATION - SCHALTBILD NETZTEIL - ALIMENTAZIONE - ESQUEMA ALIMENTACIÓN

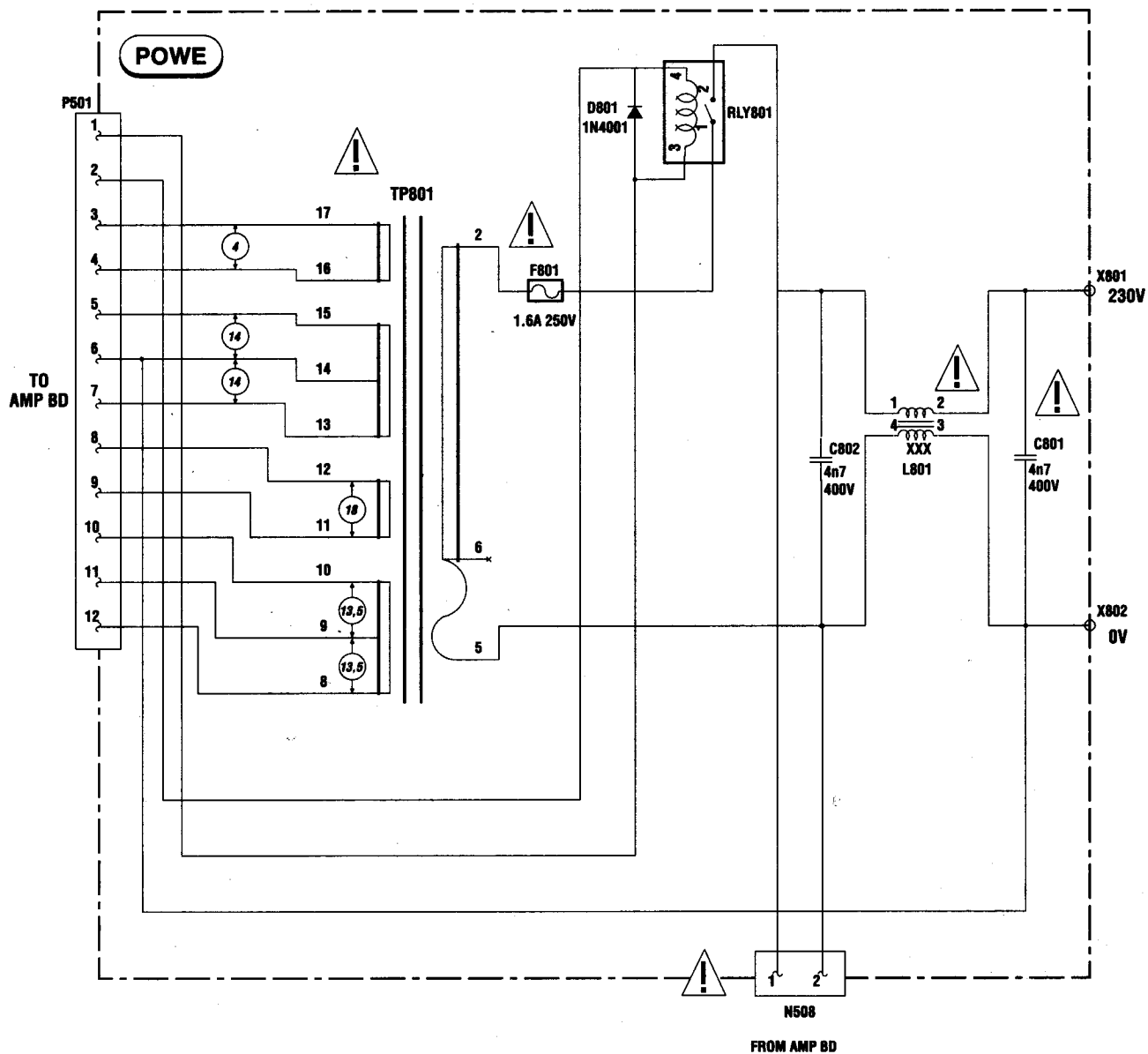

Notes:

1. Unless otherwise specified:
 - A. All resistor values are in ohms, 1/4W.
 - B. All capacitor values are in μF .
2. Replace transistors with type specified from replacement parts list.
3. All voltages taken in AUX "on" position except tuner part in FM stereo RADIO "on" position.
4. * and \triangle indicates critical safety components. Replace only with those specified from replacement parts list to maintain proper performances and safety of this unit.

MAIN SCHEMATIC DIAGRAM - SCHEMA DE LA PLATINE PRINCIPALE - SCHALTBILD HAUPTPLATINE - ESQUEMA DE LA PLATINA PRINCIPAL (TAPE PART)

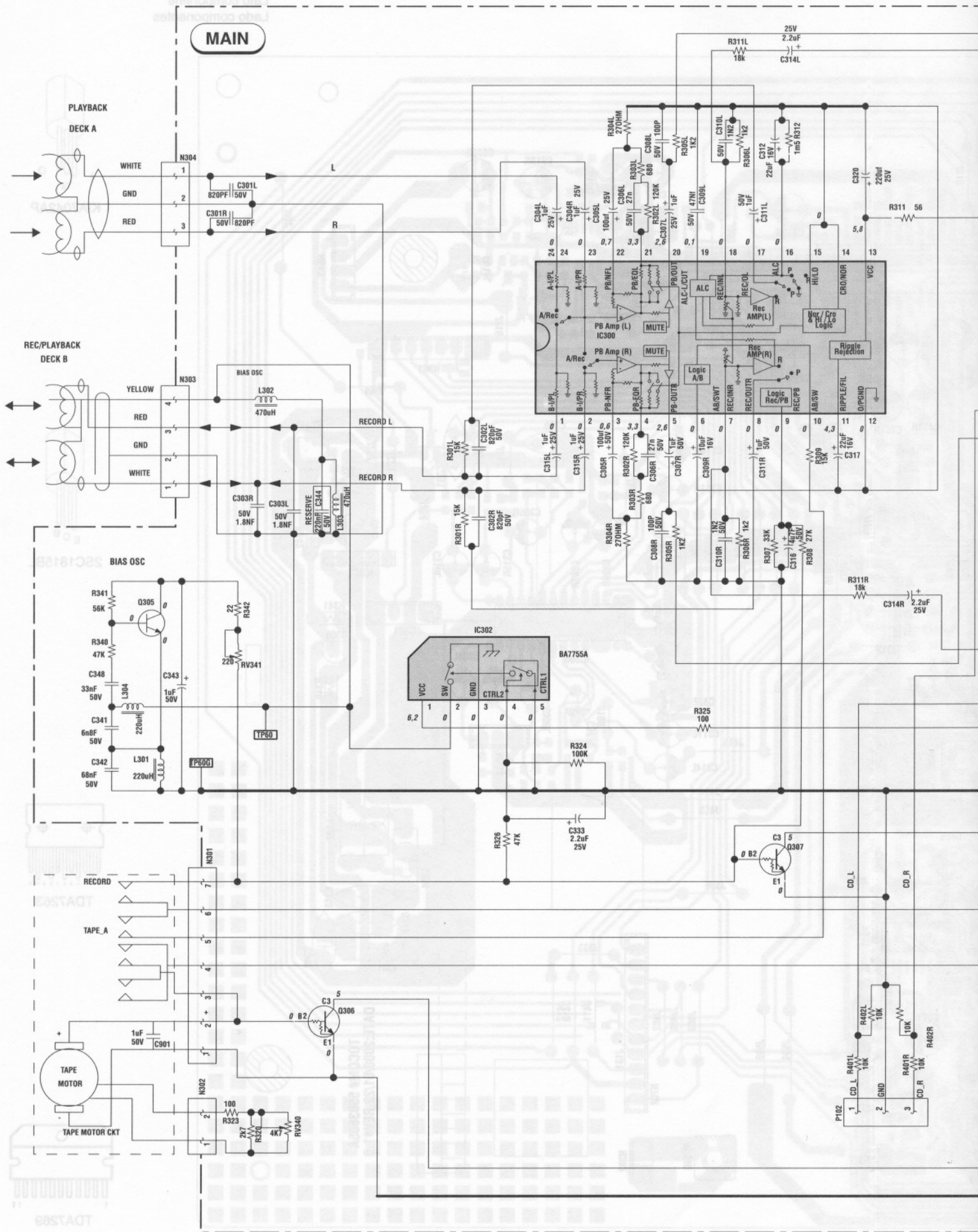

TBILD HAUPTPLATINE - SCHEMA DELLA PIASTRA PRINCIPALE -

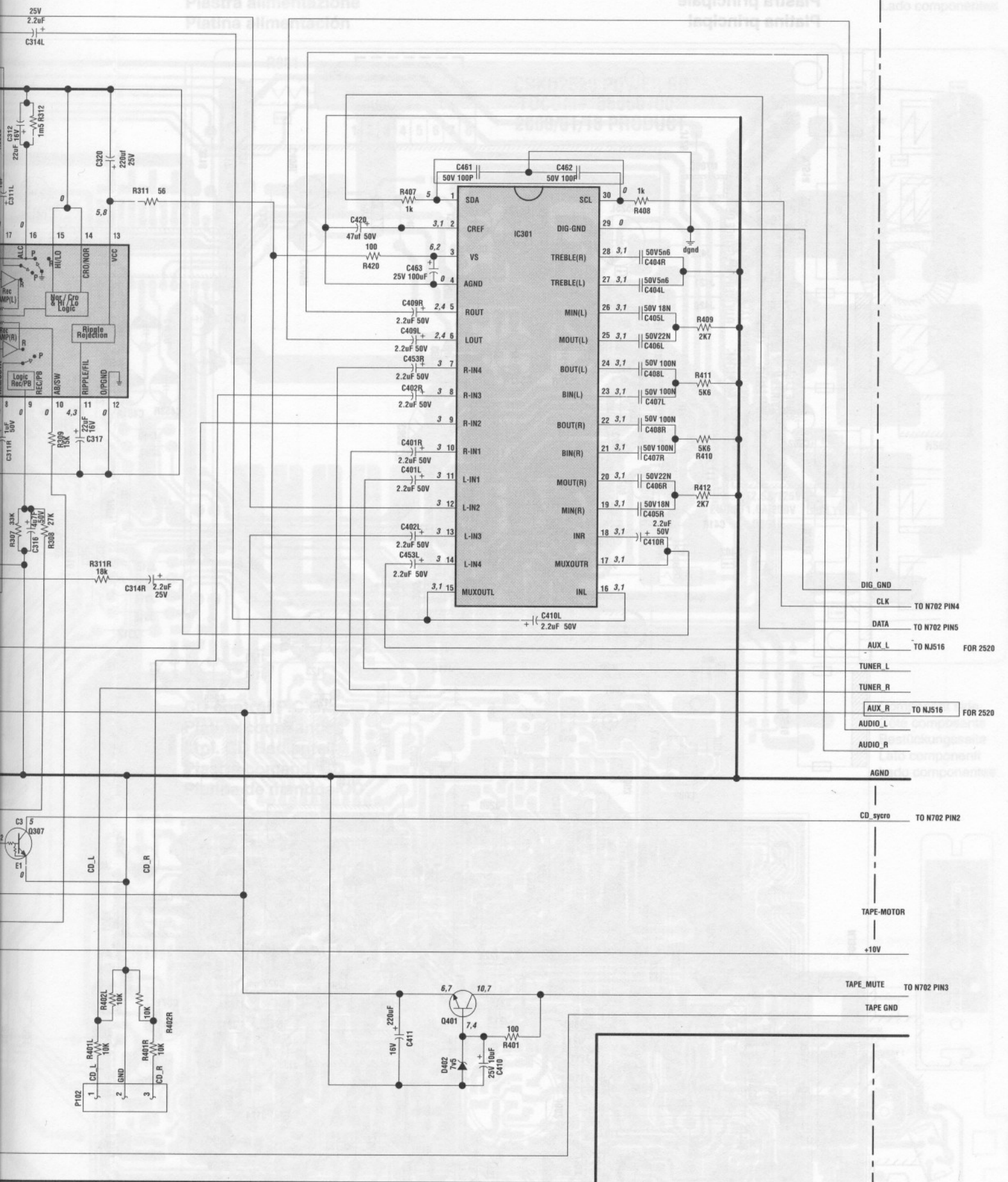

MAIN SCHEMATIC DIAGRAM - SCHEMA DE LA PLATINE PRINCIPALE -
 SCHALTBILD HAUPTPLATINE - SCHEMA DELLA PIASTRA PRINCIPALE -
 ESQUEMA DE LA PLATINA PRINCIPAL (AUDIO PART)

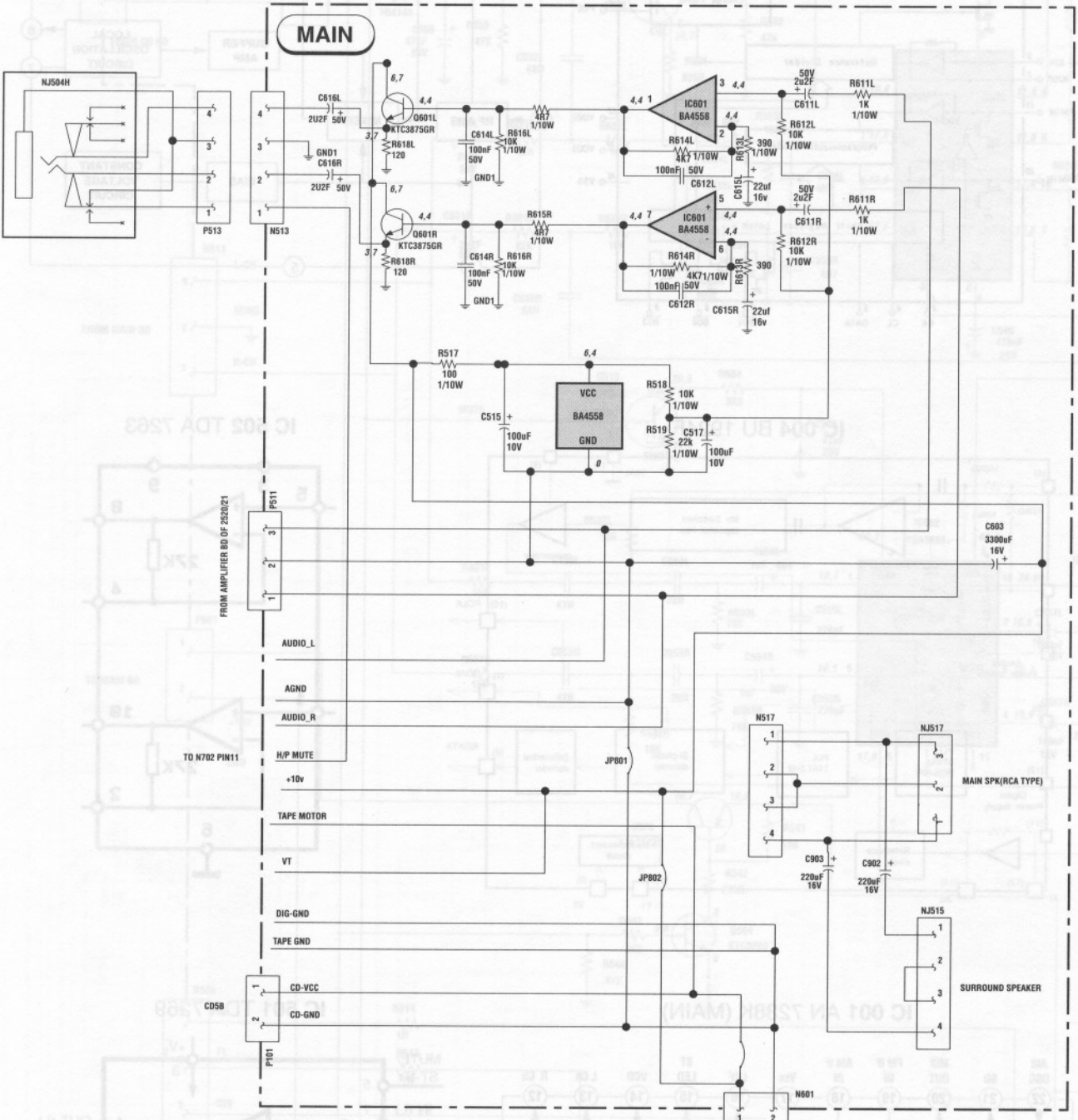

10 MΩ

MAIN SCHEMATIC DIAGRAM - SCHEMA DE LA PLATINE PRINCIPALE - SCHALTBILD HAUPTPLATINE - ESQUEMA DE LA PLATINA PRINCIPAL (TUNER PART)

MAIN

MODE	PINS OF IC002		
	7	8	9
FM-STR	1	0	1
FN-MONO	1	0	0
MW	0	1	X
LW	1	1	X



BILD HAUPTPLATINE - SCHEMA DELLA PIASTRA PRINCIPALE -



AMPLIFIER AND POWER SUPPLY SCHEMATIC DIAGRAM - SCHEMA DE L'AMPLIFICATEUR ET DE LA
 SCHEMA DEL AMPLIFICATORE E DELL ALIMENTAZIONE - ESQUEMA DEL AMPLIFICADOR Y DE LA



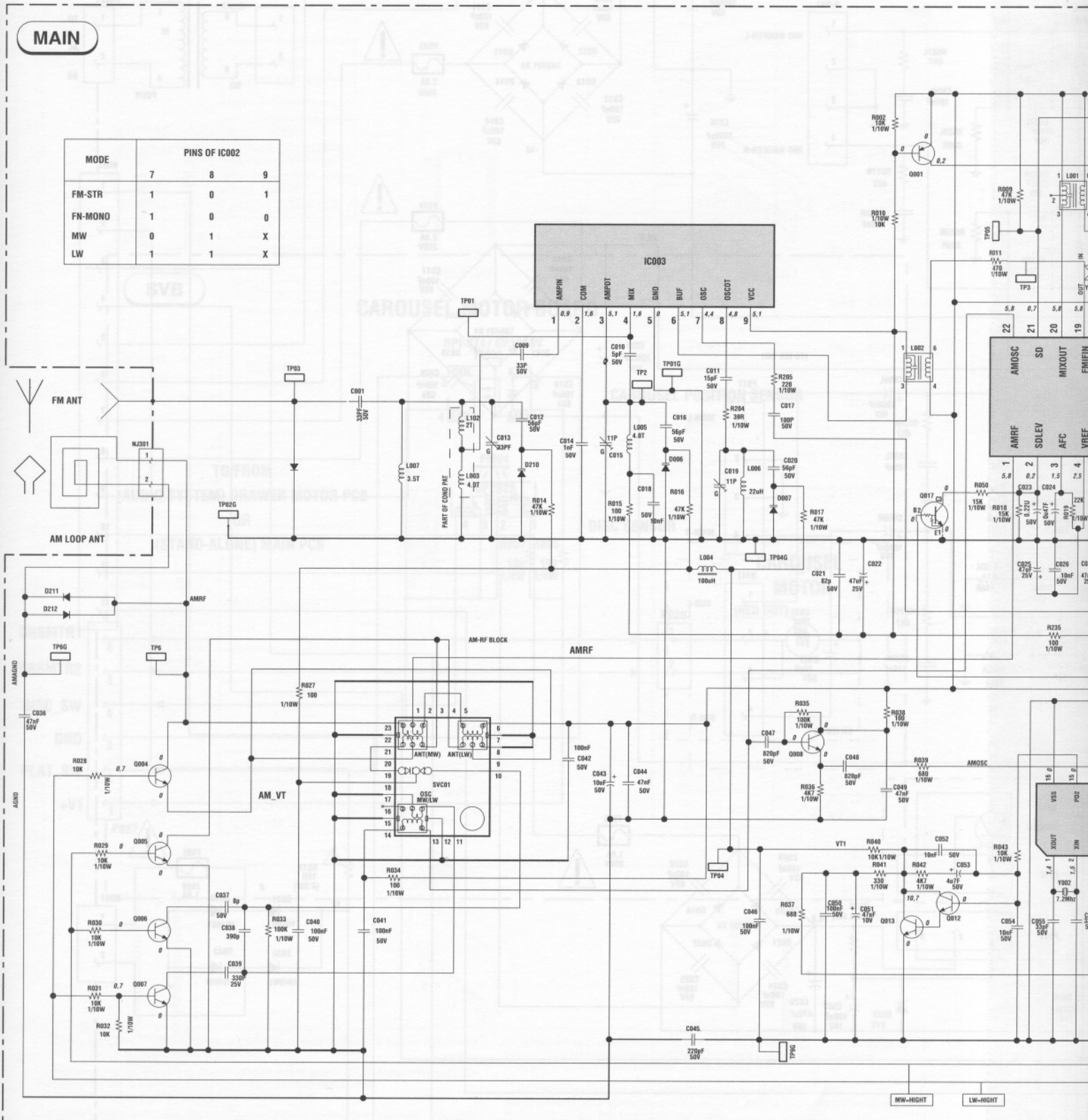
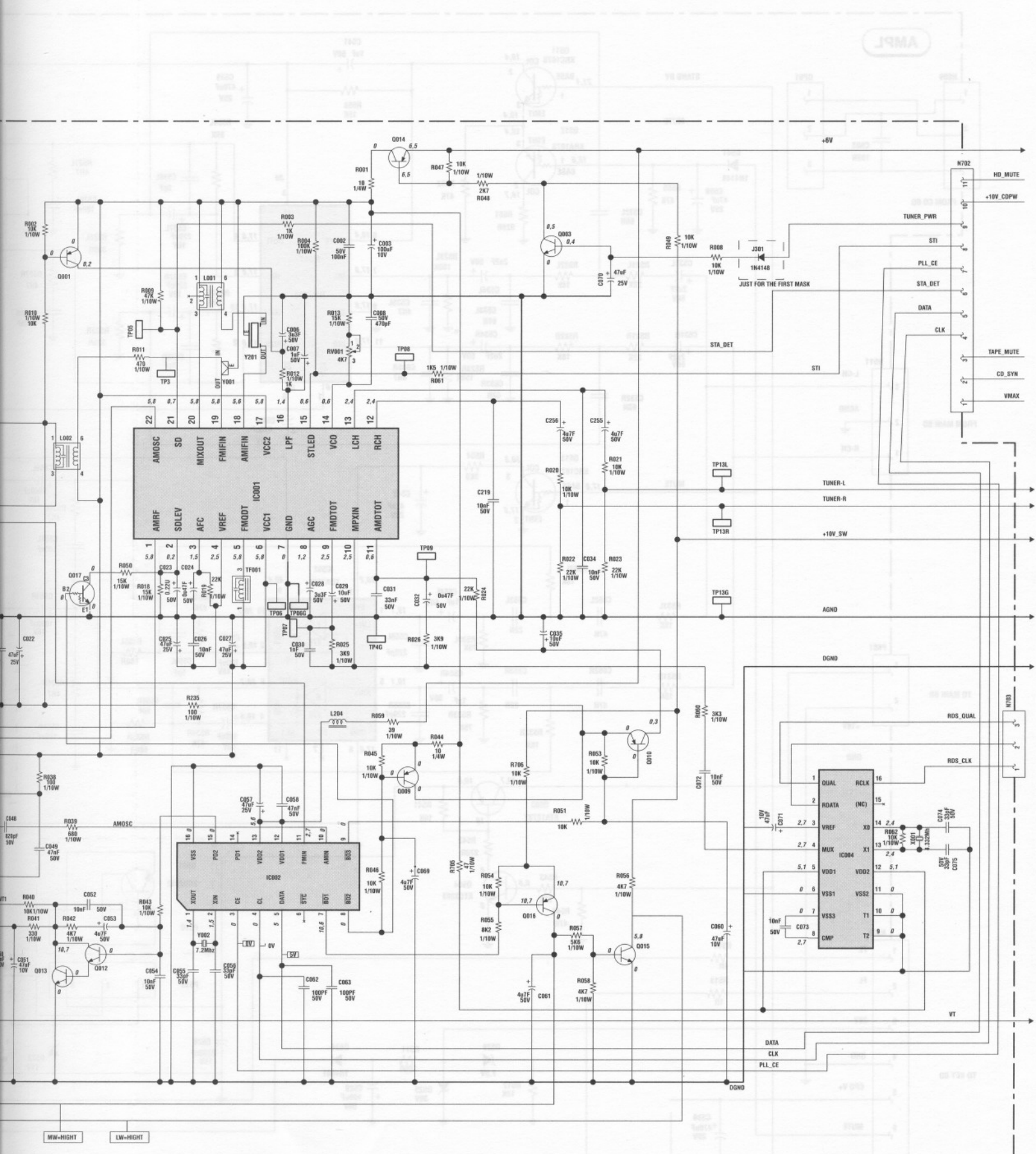
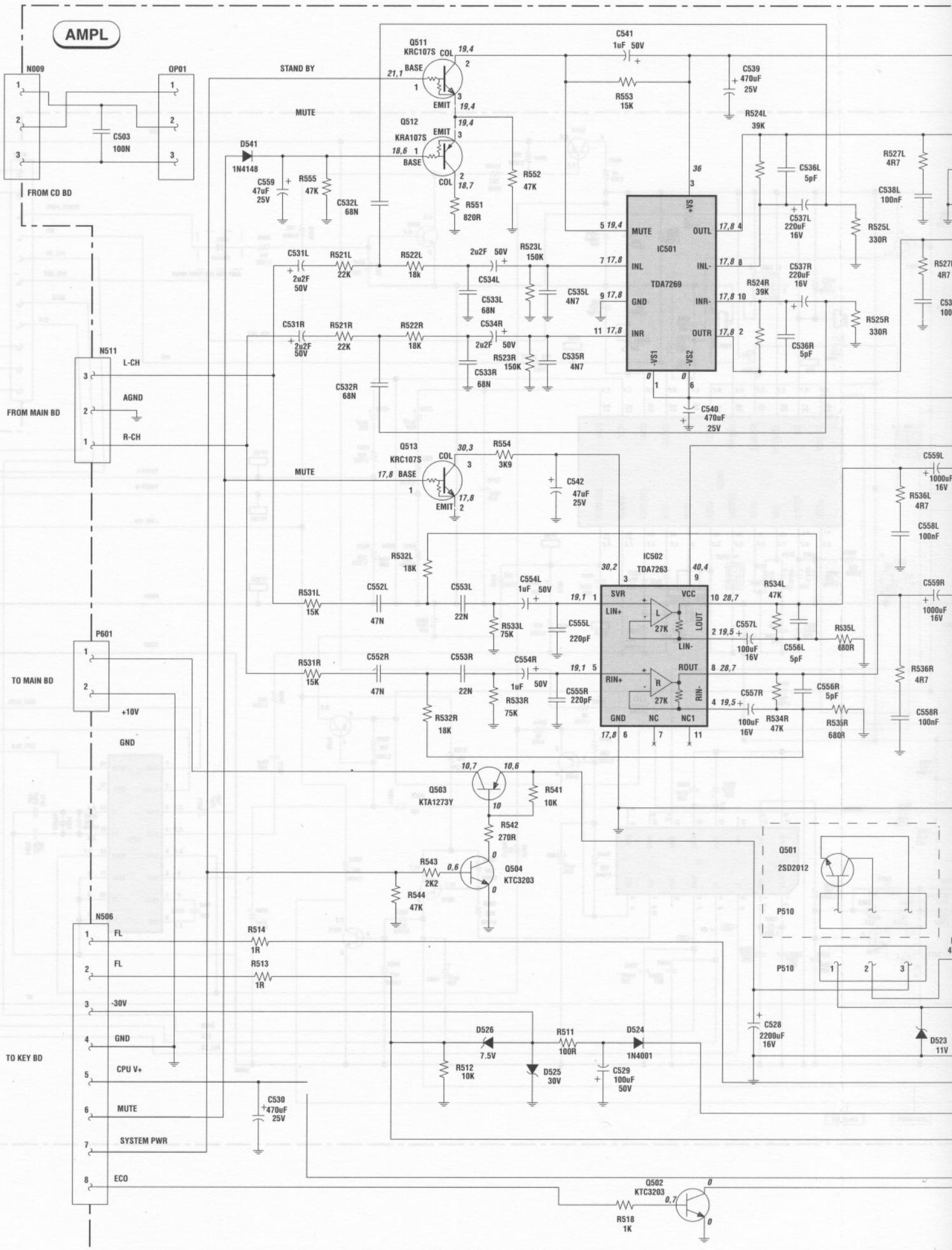
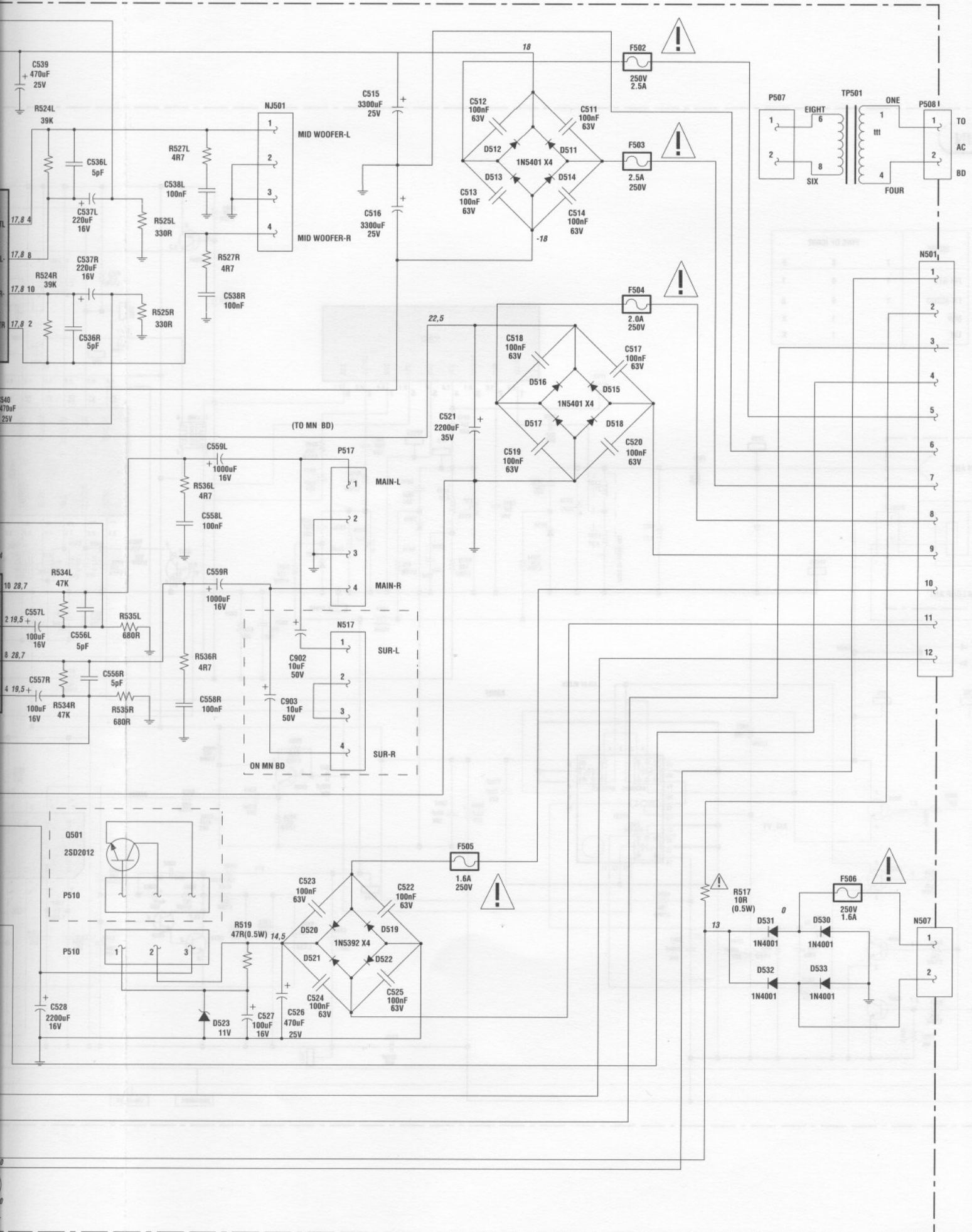

**SENSOR SCHEMATIC DIAGRAM - SCHEMA CAPTEURS CD - SCHALTBILD CD
 SENSOR - SCHEMA SENSORI CD - ESQUEMA SENSORES CD**

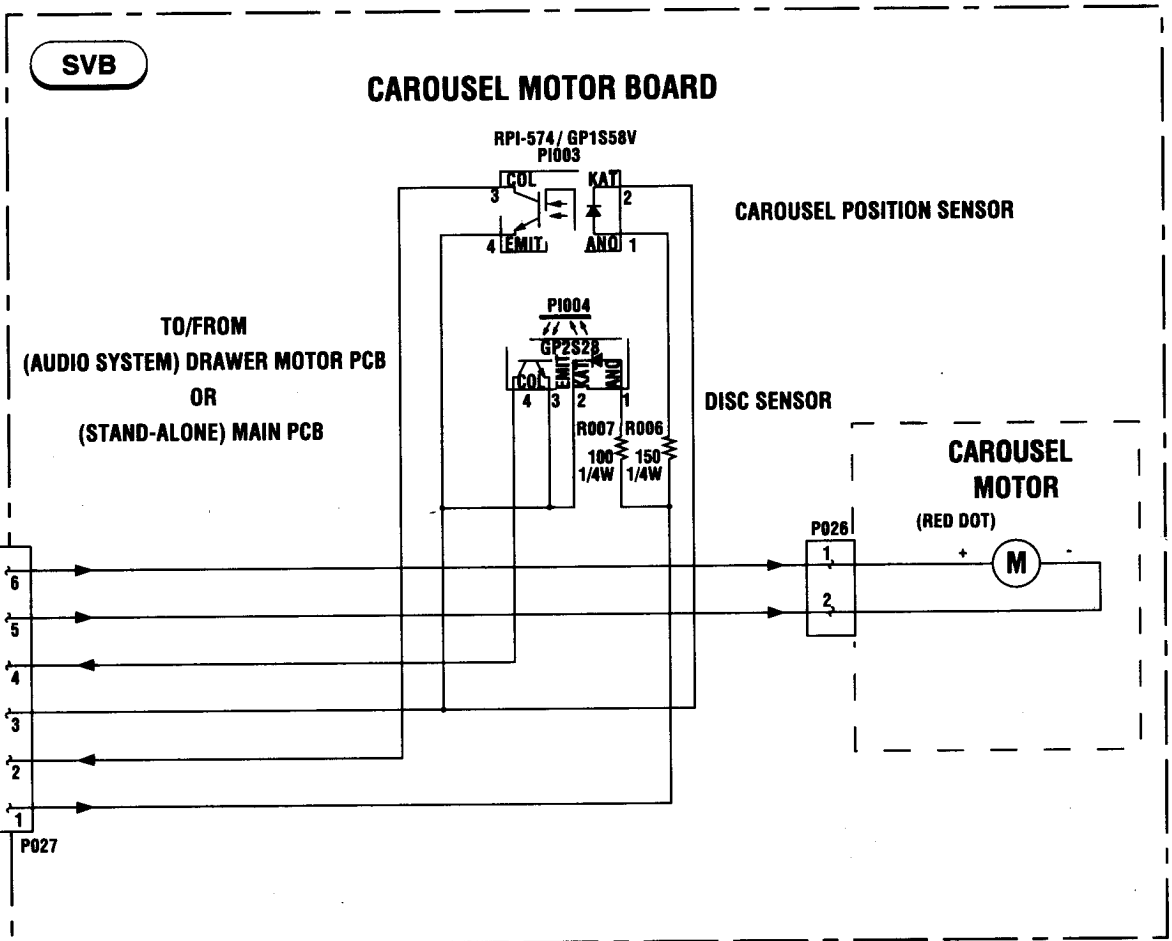

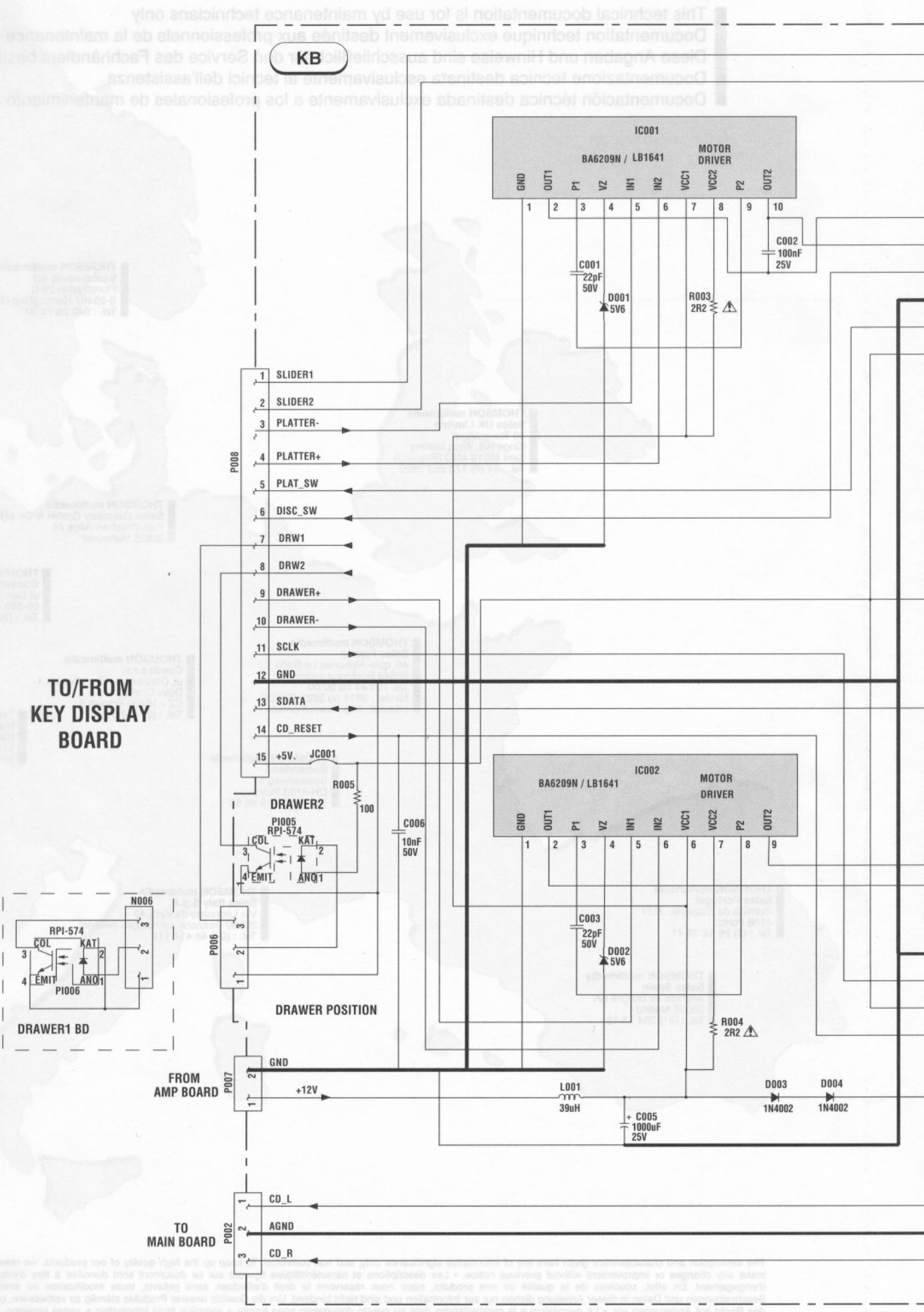

TO/FROM
KEY DISPLAY
BOARD

