

PARTS LIST
LISTE PIECES DETACHEES
ERSATZTEILLISTE
LISTA PARTI DI RICAMBIO
LISTA DE PIEZAS DE REPUESTO



THOMSON
DPL560HT
Chassis PAV5008

MODULES

MAIN	MAIN	R 55256740
AMPL	AMPLI	R 55256780
DSP	DSP	R 55256810
KDB	DISPLAY/CONTROL	R 55256790
POWE	POWER	R 55256800
RFFI	TUNER	R 55274940



IC003,005	74VHC245MTR FLAT	55257920
IC006	CS5333-KZ FLAT	55162980
IC007	CS4334-KS FLAT	45055370
IC008,009,010,011	BA4558F FLAT	20976940
IC018	CS4360-KZ FLAT	55162990
IC019,020	74VHC574MTR FLAT	55257910
IC022	AT27LV010A-90JC FLAT	35129180
IC023	CS493263-CL FLAT	55125380
IC024	CS8415A-CS FLAT	55125410
IC200	LC78211	35093840
IC202,301,302,401,402,403	KIA4558F	20920060
IC203	NJM2296 FLAT	35128070
IC303	KIA7815PI	35128320
IC304	KIA7915PI	35093430
IC305	KIA7805API	55123960
IC306,307	LM317T	△ 46043600
IC400	M62446AFP FLAT	55435360
IC404	BH3544F FLAT	55081330
IC701	UPD78P0208GF FLAT	55152930
IC702	M24C02WMN6 FLAT	35096320
IR701	GP1U287R	20852030



ICP01	PSR-5	55173540
Q001,002	KRC107S SMD	55051240
Q003,004,309,702,703,704	KTC3875GR SMD	20779850
Q081,087	DTC323TK SMD	35095360
Q082,086	DTA114YKA SMD	35095350

Q083,084,085	2SK117Y	35095520
Q101,701	KTC3203Y/KTC2120Y	20538220
Q300,605,607,615,620,622,630,635,637,645,650,652,660,665,667,675,691,692,699	KTC3200BL	20556600
Q301,302,303,304,604,619,634,649,664,680	2SA1266Y	20508210
Q305,306	KTC3198GR	20508070
Q308	KTA1298Y SMD	55050930
Q404,405,406,407,408,409,416,417	KTD1302	35093290
Q411,412,413,414,415	DTC114YKA SMD	35095340
Q425,426,427,428	DTA114YSA	10212520
Q601,602,603,606,616,617,618,621,631,632,633,636,646,647,648,651,661,662,663,666,677,678,679,693	KTA1268GR	35093320
Q608,623,638,653,668,695	2SC4137	35108350
Q609,624,639,654,669,694	KTA1024	35108380
Q610,625,640,655,670,696	KTC3206Y	35096960
Q613,626,628,658,673	2SD2589	55199190
Q614,627,629,659,674	2SB1659	55201950
Q643	2SD2493	35108360
Q644	2SB1624	35108370
Q676A,676B	DTC114YSA	35108390



D001	1SS355 SMD	20726770
D101,102,103,104,107,108,109,110,112,113,300,301,302,303,304,716	1N4002	11070780
D105	1N4751A	20743260
D111,400,401	1N5235B	20526990
D112	G5SBA60	55192330
D200,406,407,408,409,410,411,412,413,414,415,416,417,421,422,423,424,481,601,602,603,604,605,606,607,608,609,610,611,612,613,704,705,706,708,709,710	1N4148	44009209
D306,402	BZX55B5V1/ZPD5V1 2%	44035702
D308	BZX85C12	70437720
D701,711	1N5232B 5.6V	20414280
D702	LTL-1CHE3 LED	35095420



X1	12M288HZ	35128290
Y701	5MHZ	55093460



L101		70182000
-------------	--	----------

R : RECYCLED PART
: PIECE RECYCLEE
: AUSTAUSCHTEILE
: RICAMBIO RICICLATO
: MODULO REPROCESADO

For any requests, please contact THOMSON multimedia after sales service area
 Pour toutes précisions, contactez votre service après vente local THOMSON multimedia
 Für weitere Auskünfte, wenden Sie sich bitte an die THOMSON multimedia Kundendienst
 Per precisazioni, contattare l'assistenza tecnica THOMSON multimedia
 Para cualquier pregunta, por favor contactar con el responsable de zona del servicio postventa de THOMSON multimedia

VERSION 1 07 / 2002 35653960
VERSION 2 00 / 0000



EN701 55407950

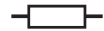

MR601,602,603, 0R39 OHM 5W 35108400
604,605,606

R322,323 0R1 OHM 5% 5W 20696190



C101,102 4N7F 20% 250V Δ 20677520

C120,121 6800UF 20% 50V Δ 20588260



T101 Δ 55249580

T102 (STAND-BY) Δ 55269220

**OTHER PARTS
AUTRES PIECES
SONSTIGE TEILE
ALTRE PARTI
OTRAS PIEZAS**

DP01 DISPLAY LCD 55198380
AFFICHEUR LCD
LCD-ANZEIGE
VISUALIZZATORE LCD
VISUALIZADOR LCD

F101 2A5T 250V TIME-LAG FUSE Δ 10246750
2A5T 250V FUSIBLE TEMPORISE
2A5T 250V SICHERUNG
2A5T 250V FUSIBILE TEMPORIZZATO
2A5T 250V FUSIBLE TEMPORIZADO

F102 500MAT TIME-LAG FUSE Δ 35117150
500MAT FUSIBLE TEMPORISE
500MAT SICHERUNG
500MAT FUSIBILE TEMPORIZZATO
500MAT FUSIBLE TEMPORIZADO

F103,104 5AT TIME-LAG FUSE Δ 35043570
5AT FUSIBLE TEMPORISE
5AT SICHERUNG
5AT FUSIBILE TEMPORIZZATO
5AT FUSIBLE TEMPORIZADO

F105,106 2AT 250V TIME-LAG FUSE Δ 48029300
2AT 250V FUSIBLE TEMPORISE
2AT 250V SICHERUNG
2AT 250V FUSIBILE TEMPORIZZATO
2AT 250V FUSIBLE TEMPORIZADO

HD601 JACK SOCKET 35097390
PRISE JACK
BUCHSE
PRESA JACK
TOMA JACK

JA300 CINCH SOCKET 3P 35130490
PRISE CINCH 3P
CHINCH-BUCHSE 3P
PRESA CINCH 3P
TOMA CINCH 3P

JK104 LOUDSPEAKER SOCKET X8 55158030
PRISE HAUT PARLEUR X8
LAUTSPRECHERBUCHSE X8
PRESA ALTOPARLANTE X8
TOMA ALTAVOZ X8

JK105 LOUDSPEAKER SOCKET X4 55158020
PRISE HAUT PARLEUR X4
LAUTSPRECHERBUCHSE X4
PRESA ALTOPARLANTE X4
TOMA ALTAVOZ X4

JK106 CINCH SOCKET X9 55278730
PRISE CINCH X9
CHINCH-BUCHSE X9
PRESA CINCH X9
TOMA CINCH X9

JK107,108 CINCH SOCKET X3 35128240
PRISE CINCH X3
CHINCH-BUCHSE X3
PRESA CINCH X3
TOMA CINCH X3

JK109 CINCH SOCKET X6 35128230
PRISE CINCH X6
CHINCH-BUCHSE X6
PRESA CINCH X6
TOMA CINCH X6

JK111 CINCH SOCKET X1 55288330
PRISE CINCH X1
CHINCH-BUCHSE X1
PRESA CINCH X1
TOMA CINCH X1

OPI OPTICAL SOCKET 35109050
PRISE OPTIQUE
OPTICAL-BUCHSE
PRESA OTTICA
TOMA OPTICO

RCA1 CINCH SOCKET X1 55188070
PRISE CINCH X1
CHINCH-BUCHSE X1
PRESA CINCH X1
TOMA CINCH X1

RY101 SDT-S-112LMR RELAY 12V Δ 35095470
SDT-S-112LMR RELAIS 12V
SDT-S-112LMR RELAIS 12V
SDT-S-112LMR RELEE 12V
SDT-S-112LMR RELEE 12V

SW701,702, 20404680
703,704,705, MICROSWITCH
706,707,708, MICRO CONTACTEUR
709,710,711, MIKROSCALTER
712,713,714, MICROINTERRUTTORE
715,716,717, MICROCONTACTOR
718,719

**EQUIPMENT/PRESENTATION
EQUIPEMENT/PRESENTATION
AUSSTATTUNG/GEHAUSE
PARTI VARIE
EQUIPO/PRESENTACION**

RC560 REMOTE CONTROL 21178860
RC560 TELECOMMANDE
RC560 FERNBEDIENUNG
RC560 TELECOMANDO
RC560 TELEMANDO

DPL560HT LOUDSPEAKER BOX ASSY X6 55280250
DPL560HT ENCEINTE ACUSTIQUES X6
DPL560HT LAUTSPRECHERBOX K.P.L. X6
DPL560HT CASSA ACUSTICA COMPLETO X6
DPL560HT CAJA ACUSTICA EQUIPADO X6

CENTRAL LOUDSPEAKER BOX 35653980
ENCEINTE ACOUSTIQUE CENTRALE
CENTRAL LAUTSPRECHERBOX
CASSA ACUSTICA PRINCIPALE CENTRALE
CAJA ACUSTICA PRINCIPAL CENTRAL

MAIN LOUDSPEAKER BOX RIGHT OR LEFT 35653990
ENCEINTE ACOUS.PRINCIP. DROITE OU GAUCHE
MAIN LAUTSPRECHERBOX RECHTS ODER LINKS
CASSA ACUSTIC.PRINCIP. DESTRA O SINISTRA
CAJA ACUSTIC.PRINCIP.DERECHA O IZQUIERDA

SURROUND LOUDSPEAKER BOX RIGHT OR LEFT 35654000
ENCEINTE ACOUS.SURROUND DROITE OU GAUCHE
SURROUND LAUTSPRECHERBOX RECH. OD. LINKS
CASSA ACUSTICA SURR. DESTRA O SINISTRA
CAJA ACUSTICA SURR. DERECHA O IZQUIERDA

LOUDSPEAKER BOX SUBWOOFER 35653970
ENCEINTE ACOUSTIQUE SUBWOOFER
LAUTSPRECHERBOX SUBWOOFER
CASSA ACUSTICA SUBWOOFER
CAJA ACUSTICA SUBWOOFER

FOLDING BOX 55274170
EMBALLAGE CARTON
KARTON
IMBALLGGIO CARTONE
EMBALAJE CARTON

FM ANTENNA 35103510
ANTENNE FM
FM ANTENNE
ANTENNA FM
ANTENA FM

AM ANTENNA 20690640
ANTENNE AM
AM ANTENNE
ANTENNA AM
ANTENA AM

AM ANTENNA HOLDER 20690520
SUPPORT ANTENNE AM
AM ANTENNENHALTER
SUPPORTO ANTENNA AM
SOPORTE ANTENA AM

CONNECTION LEAD 1+1 CINCH 35093990
CORDON DE LIAISON 1+1 CINCH
ANSCHLUSSKABEL 1+1 CINCH
CAVO DI ALLACCIAMENTO 1+1 CINCH
CAVO DI ALLACCIAMENTO 1+1 CINCH

CONNECTION LEAD 2+2 CINCH (RED-WHITE) 25347770
CORDON DE LIAISON 2+2 CINCH(ROUGE-BLANC)
ANSCHLUSSKABEL 2+2 CINCH (ROT-WEISS)
CAVO DI ALLACCIAM.2+2 CINCH(ROSSA-BIANC)
CABLE DE ENLACE 2+2 CINCH (ROJA-BIANCO)

POWER SUPPLY LEAD Δ 10260820
CORDON D'ALIMENTATION
NETZKABEL
CAVO DI ALIMENTAZIONE
CABLE DE ALIMENTACION

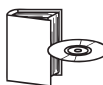

DPL560HT UM TH 55274180
DPL560HT NU TH
DPL560HT BA TH
DPL560HT IU TH
DPL560HT IU TH

DPL560HT PARTS LIST 35653960
DPL560HT LISTE DE PIECES DETACHEES
DPL560HT ERSATZTEILLISTE
DPL560HT LISTA PARTI DI RICAMBIO
DPL560HT LISTA DE PIEZAS DE REPUESTO

PAV5008 TH SERVICE MANUAL 35653950
PAV5008 TH DOCUMENTATION TECHNIQUE
PAV5008 TH TECHNISCHE DOKUMENTATION
PAV5008 TH DOCUMENTAZIONE TECNICA
PAV5008 TH DOCUMENTACION TECNICA

**CHASSIS AND PRESENTATION
CHASSIS ET PRESENTATION
CHASSIS UND GEHAEUSETEILE
TELAIO E DI PRESENTAZIONE
CHASIS Y PRESENTACION**

AMPL	AMPLI BOARD AMPLI PLATINE AMPLI PLATTE AMPLI PIASTRA AMPLI PLATINA	55256780
DSP	DSP BOARD DSP PLATINE DSP PLATTE DSP PIASTRA DSP PLATINA	55256810
KDB	DISPLAY/CONTROL BOARD DISPLAY/CONTROL PLATINE DISPLAY/CONTROL PLATTE DISPLAY/CONTROL PIASTRA DISPLAY/CONTROL PLATINA	55256790
MAIN	MAIN BOARD MAIN PLATINE MAIN PLATTE MAIN PIASTRA MAIN PLATINA	55256740
POWE	POWER BOARD POWER PLATINE POWER PLATTE POWER PIASTRA POWER PLATINA	55256800
RFFI	TUNER BOARD TUNER PLATINE TUNER PLATTE TUNER PIASTRA TUNER PLATINA	55274940
020	FRONT PANEL FACADE FRONTPLATTE PANNELLO FRONTALE PANEL FRONTAL	55272100
030	LOWER FRONT PANEL PANNEAU FRONTAL INFERIEUR UNTER-FRONTPLATTE PANNELLO FRONTALE INFERIORE PANEL FRONTAL INFERIOR	55272130
040	LOWER SIDE PANEL RIGHT PANNEAU INFERIEUR LATERAL DROIT SEITENTEIL RECHTS PANNELLO LATERALE INFERIORE DESTRO PANEL LATERAL INFERIOR DERECHO	55272150
050	LOWER SIDE PANEL LEFT PANNEAU INFERIEUR LATERAL GAUCHE SEITENTEIL LINKS PANNELLO LATERALE INFERIORE SINISTRO PANEL LATERAL INFERIOR IZQUIERDO	55272170
060	BUTTON COVER PANEL ENJOLIVEUR SUPERIEUR BOUTON TASTE ZIERRAHMEN OBEN FINIZIONE SUPERIORE TASTO EMBELLECEDOR SUPERIOR TECLA	55272230
070	DISPLAY WINDOW GLACE AFFICHEUR ANZEIGEFENSTER VETRO DEL VISUALIZZATORE CRISTAL DEL VISUALIZADOR	55272190
080	VOLUME KNOB BOUTON VOLUME LAUTSTAERKEKNOPF ROTELLA DI PLASTICA VOLUME RUEDA PLASTICA MANDO	55272210
090	SET BUTTON TOUCHE SET SET TASTE TASTO SET TECLA SET	55257330

100	ON/OFF BUTTON TOUCHE MARCHE/ARRET EIN-AUS TASTE TASTO ACCESO/SPENTO TECLA MARCHA/PARADA	55284630
105	SOURCE UP BUTTON TOUCHE SOURCE UP TASTE SOURCE UP TASTO SOURCE UP TECLA SOURCE UP	55281460
110	MUTE/BASS/LEVEL BUTTON TOUCHE MUTE/BASS/LEVEL MUTE/BASS/LEVEL TASTE TASTO MUTE/BASS/LEVEL TECLA MUTE/BASS/LEVEL	55257370
115	SOURCE DOWN BUTTON TOUCHE SOURCE DOWN TASTE SOURCE DOWN TASTO SOURCE DOWN TECLA SOURCE DOWN	55281470
130	SURROUND MODE BUTTON TOUCHE SURROUND MODE SURROUND MODE TASTE TASTO SURROUND MODE TECLA SURROUND MODE	55257390
140	DSP MODE BUTTON TOUCHE DSP MODE DSP MODE TASTE TASTO DSP MODE TECLA DSP MODE	55257410
145	BUTTON STRIP 10T FUNCTIONS BARRETTE 10 TOUCHES FONCTION TASTENLEISTE FUNKTIONEN 10T PIATTINA 10 TASTI FUNZIONI PLACA DE 10 TECLAS FUNCIONES	55280330
200	UPPER CASE ASSY COFFRET SUPERIEUR GEHAEUSE OBEN CASSA SUPERIORE CAJA SUPERIOR	55380090

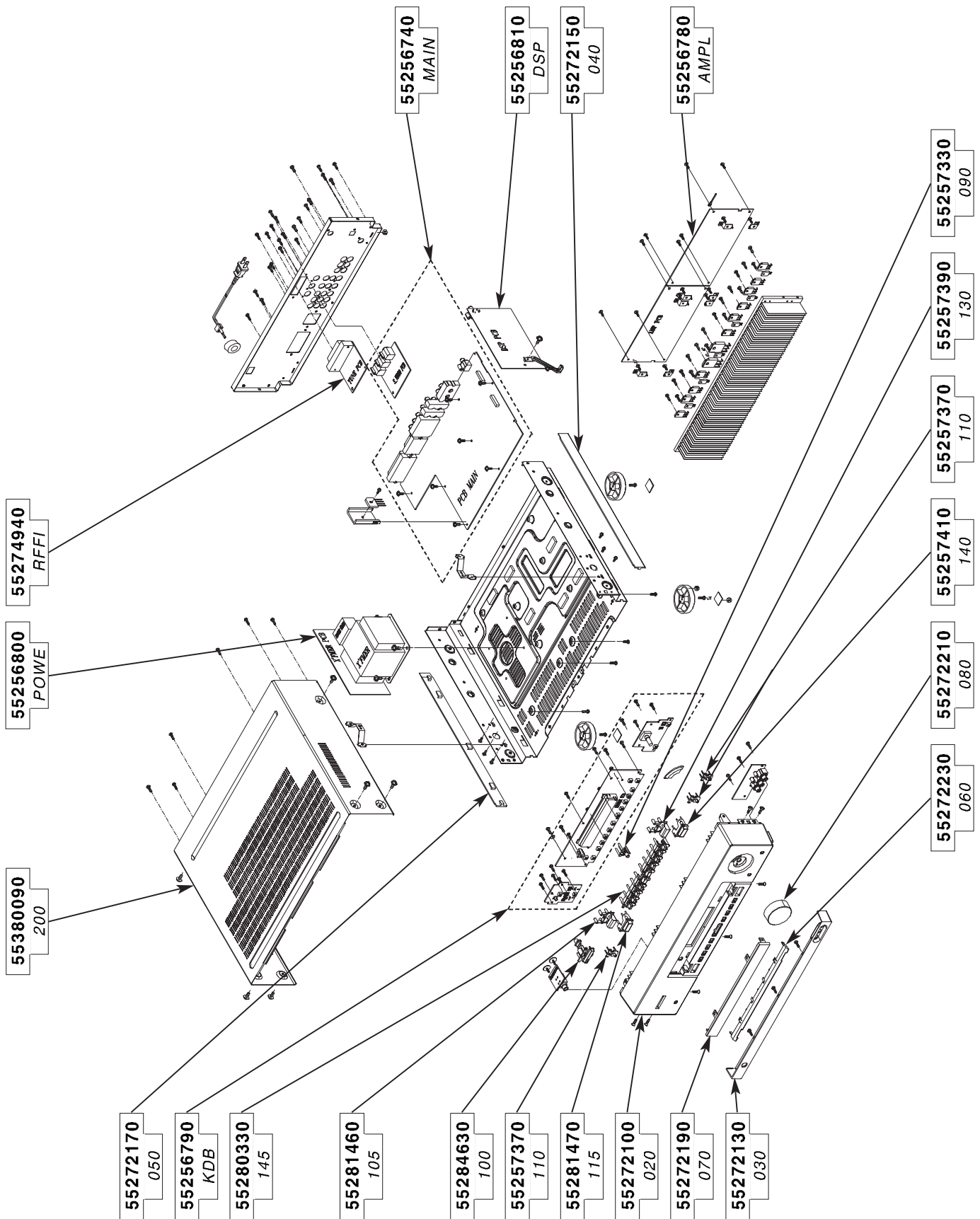

**CHASSIS AND PRESENTATION / CHASSIS ET PRESENTATION / CHASSIS UND GEHAEUSETEILE /
TELAIO E DI PRESENTAZIONE / CHASIS Y PRESENTACION**

DPL560HT

4/4

The description and characteristics given here are of informative significance only, and non committal. To keep up the high quality of our products, we reserve the right to make any changes or improvement without previous notice. • Les descriptions et caractéristiques figurant sur ce document sont données à titre d'information et non d'engagement. En effet, soucieux de la qualité de nos produits, nous nous réservons le droit d'effectuer, sans préavis, toute modification ou amélioration. • Die Beschreibungen und Daten in dieser Anleitung dienen nur zur Information und sind nicht bindend. Um die Qualität unserer Produkte ständig zu verbessern, behalten wir uns das Recht auf Änderungen vor. • Le descrizioni e le caratteristiche date su questo documento sono fornite a semplice titolo informativo e senza impegno. Ci riserviamo il diritto di eseguire, senza preavviso, qualsiasi modifica o miglioramento. • Las descripciones y características que figuran en este documento se dan a título de información y no de compromiso. En efecto, en bien de la calidad de nuestros productos, nos reservamos el derecho de efectuar, sin previo aviso, cualquier modificación o mejora.

POWER SUPPLY SCHEMATIC DIAGRAM - SCHEMA DES CIRCUITS D'ALIMENTATIONS - SCHALTBILD NETZTEIL - SCHEMA DEI CIRCUITI DI ALIMENTAZIONE - ESQUEMA DE LOS CIRCUITOS DE ALIMENTACIÓN

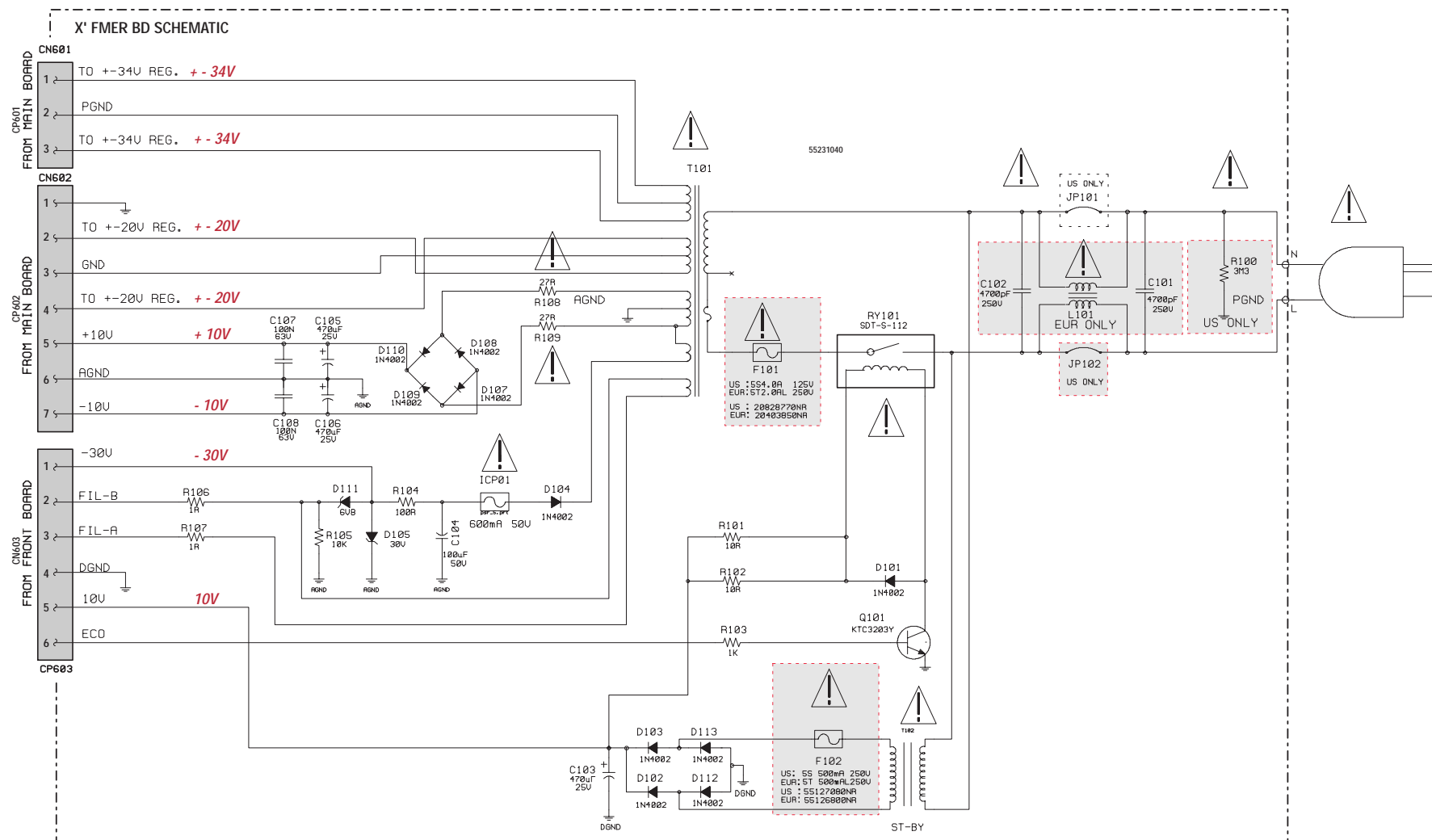

Power supply P.C.B.
Platine alimentation
Ltpl. Netzteil
Piastra alimentare
Platina alimentación

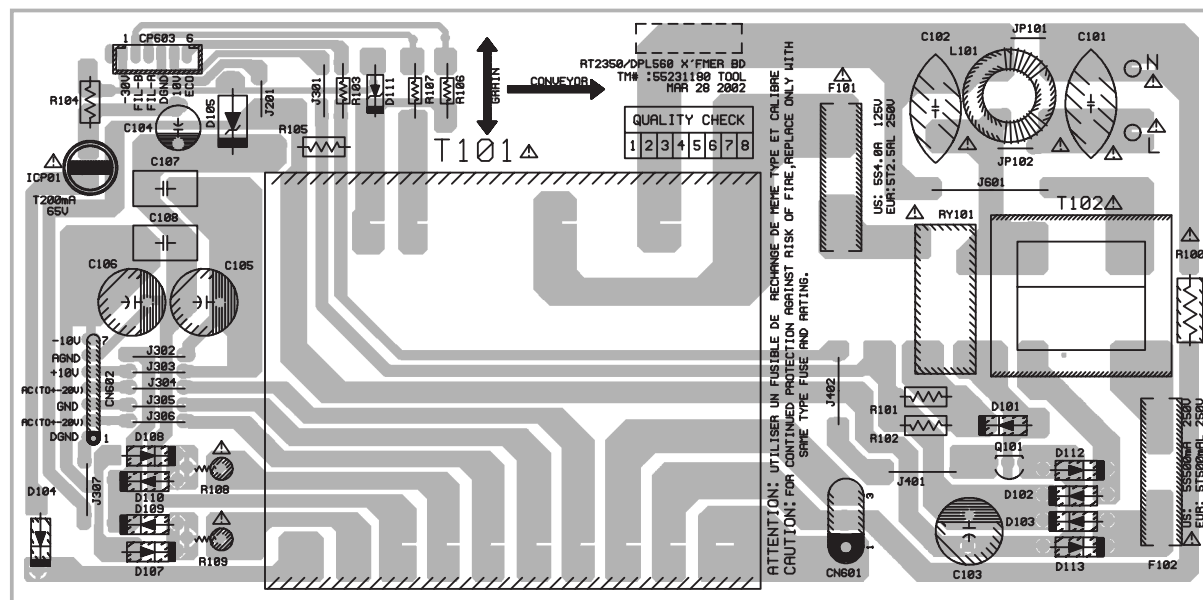

CONTROL / DISPLAY SCHEMATIC DIAGRAM - SCHEMA COMMANDES / AFFICHEUR - BEDIENTEIL / ANZEIGE SCHALTBILD - SCHEMA COMANDI / INDICATORE - ESQUEMA MANDOS / INDICADOR

NOTES:

1. Unless otherwise specified:
A. All resistor values are in ohms, 1/16W
B. All Capacitor values are in uF
2. Voltages are positive with respect to ground under no signal conditions and volume control minimum
3. Replace transistors with type specified from replacement parts list
4. Unless otherwise stated, all voltages taken in radio "on" position
5. * and Δ indicates critical safety components. Replace only with those specified from replacement parts list to maintain proper performance and safety of this unit.

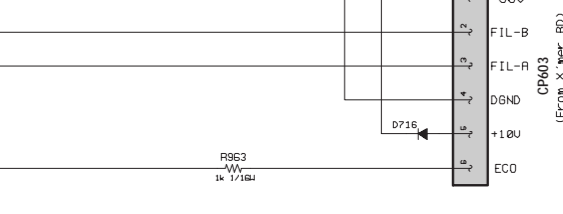
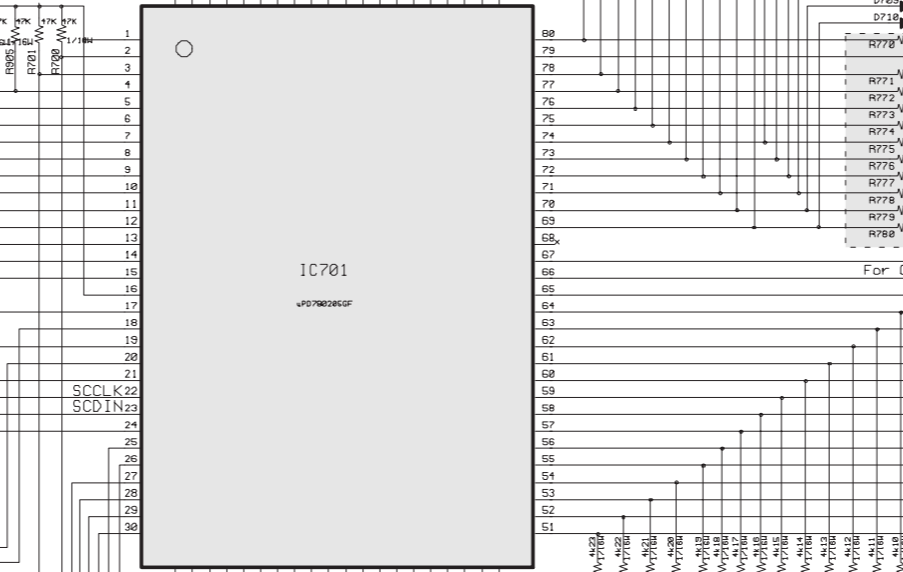
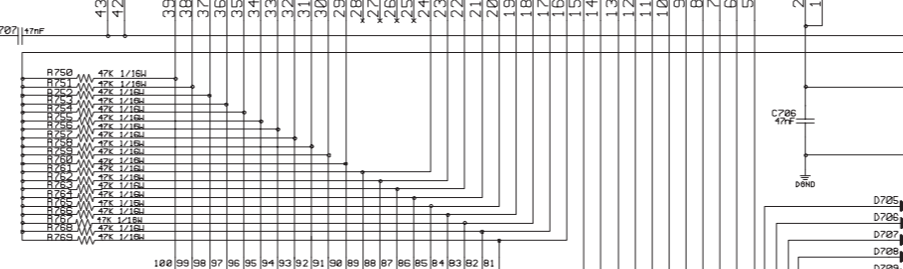
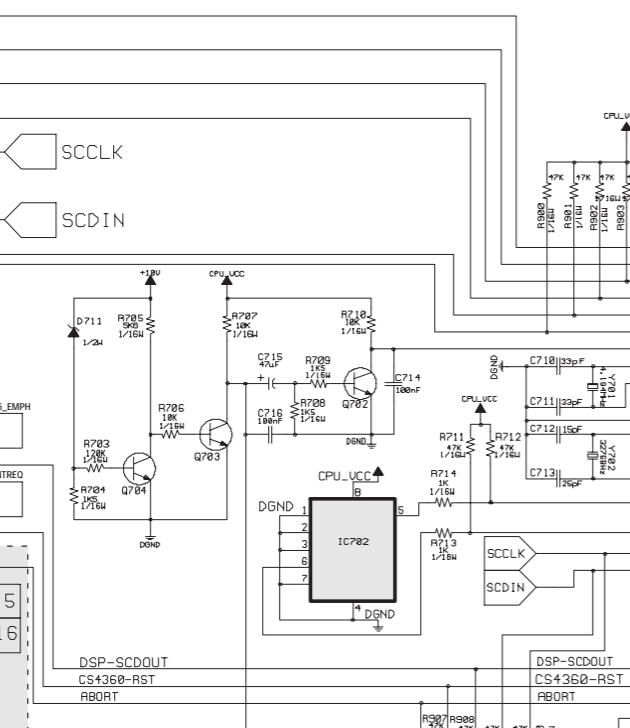
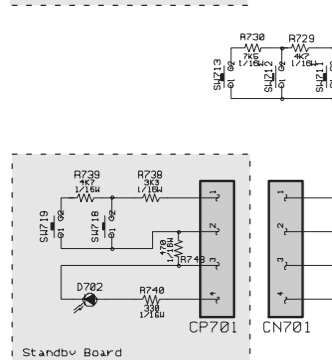
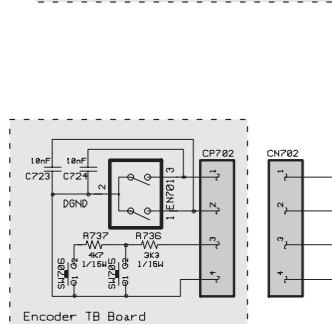
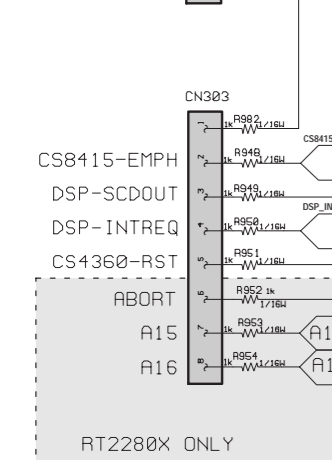
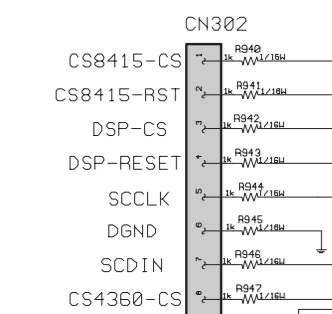
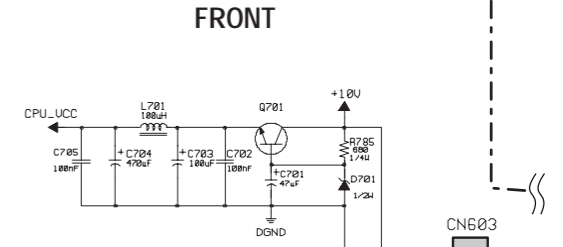
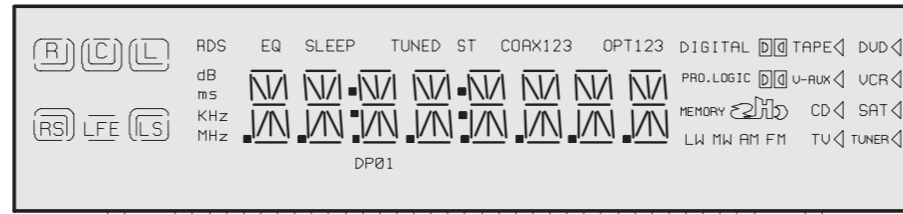
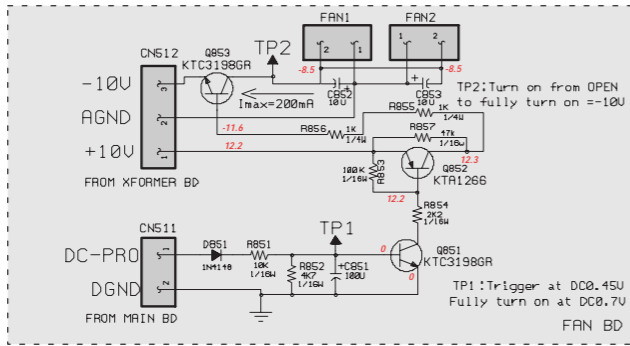

ref.	w/diode	w/o diode
D705	W/LW (MW)	WO/LW (AM)
D706	W/TUNER PS	WO/TUNER PS
D707	W/RDS	NO RDS
D708	DSP EXT.MEM	DSP INT.MEM
D709	AM 9K/STEP	AM 10K/STEP
D710	FM 50K/STEP	FM 200K/STEP

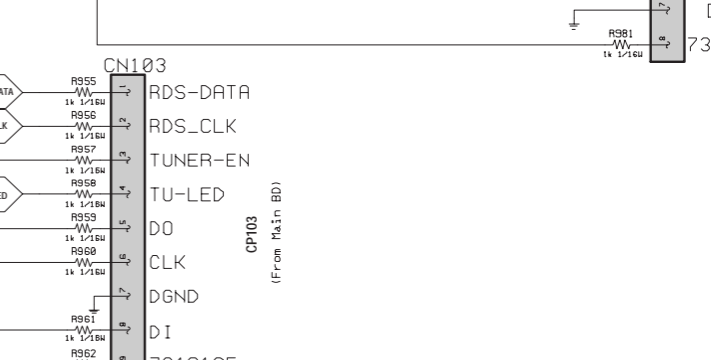
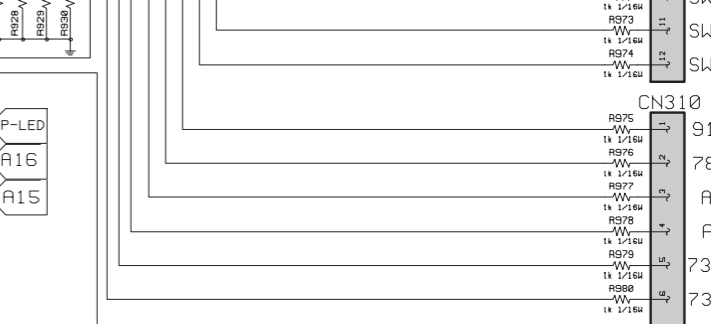
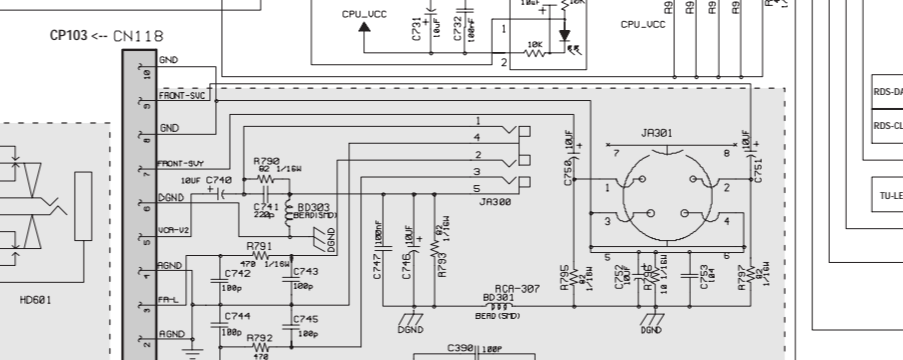
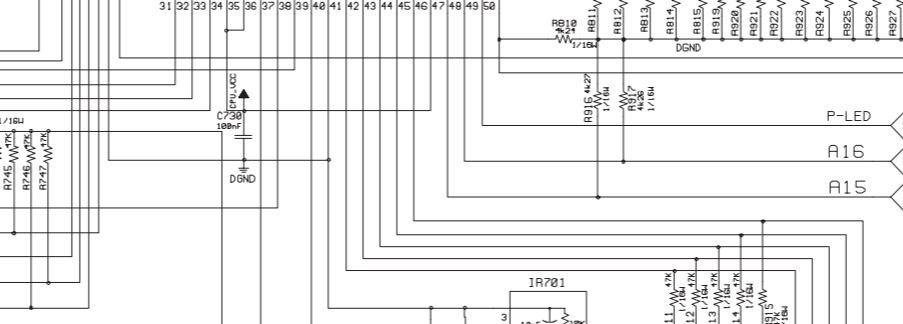
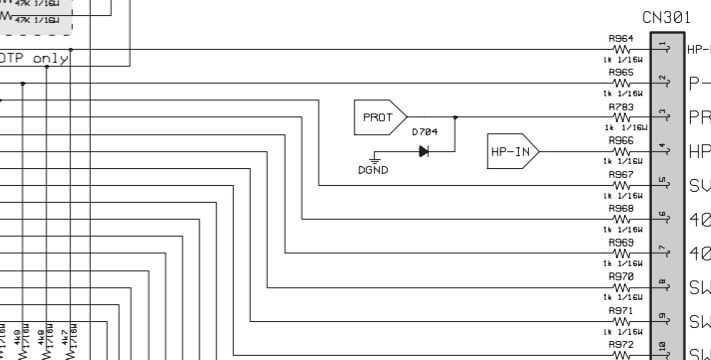

MAIN SCHEMATIC DIAGRAM - SCHEMA DE LA PLATINE PRINCIPALE - GRUNDPLATTE SCHALTBILD - SCHEMA DELLA PIASTRA PRINCIPALE - ESQUEMA DE LA PLATINA PRINCIPAL (PRE-AMPLIFIER PART)

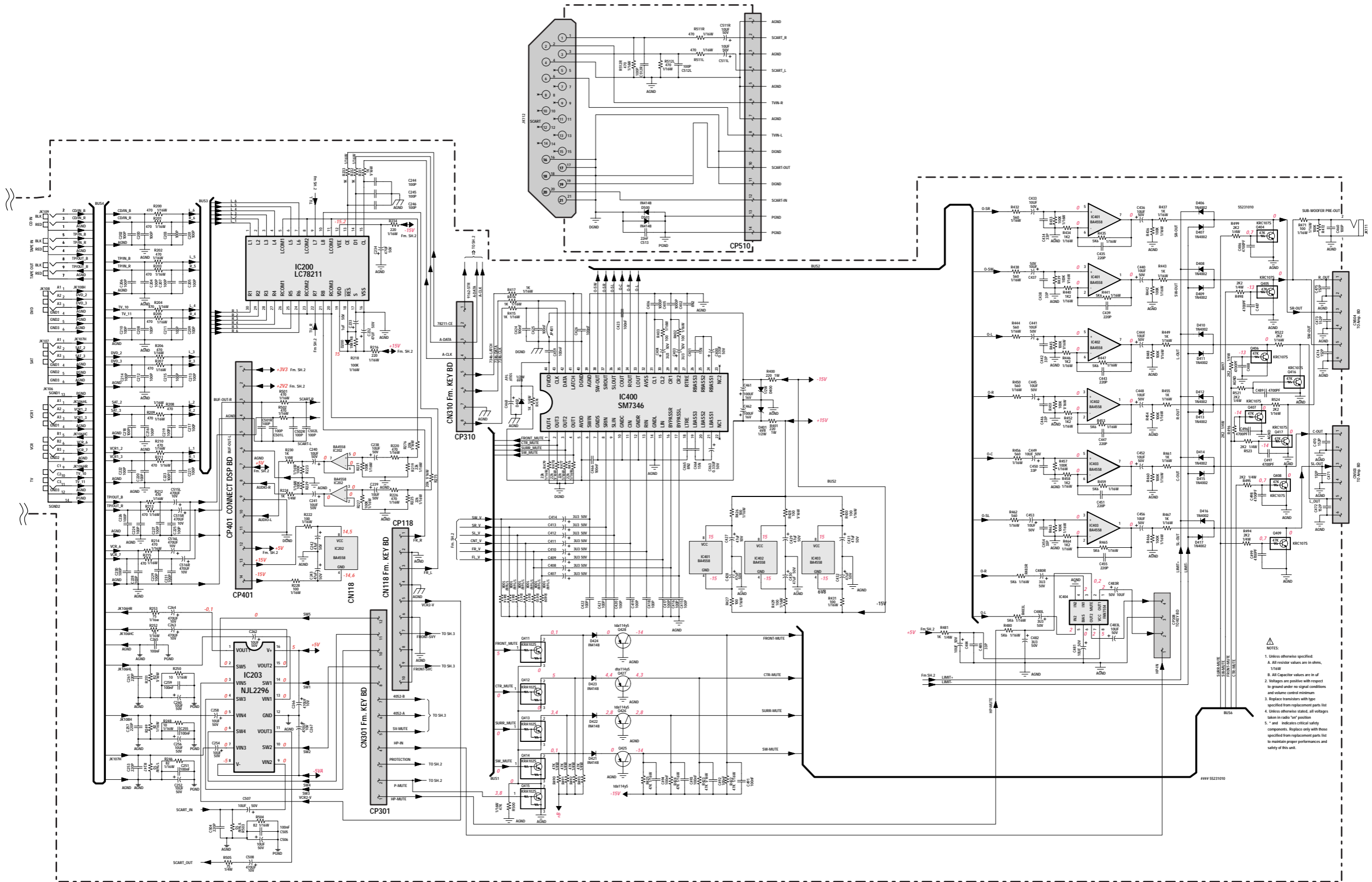

DIGITAL PROCESSING SCHEMATIC DIAGRAM - SCHEMA DU TRAITEMENT DIGITAL - SCHALTBIKD DIGITALVERARBEITUNG - SCHEMA ELABORAZIONE DIGITALE - ESQUEMA DEL TRATAMIENTO DIGITAL

