

# Audio/Communication Basic Service Data



PROSCAN



Latin America After Sales

Indianapolis IN 46290 U.S.A.

## SERVICE DATA INDEX

	<b>Page Number</b>
Exploded View .....	1-4
Printed Circuit Board .....	1-5
Replacement Parts .....	1-3
Safety Precautions .....	1-2
Schematic .....	1-6

**CAUTION:** Modification or repair of this unit by unauthorized persons is a direct violation of FCC Rules Part 68.216 and could result in risk of electric shock. You are urged to contact a qualified factory authorized service facility for repairs.

### **SAFETY NOTICE**

#### **USE ISOLATION TRANSFORMER WHEN SERVICING**

Components having special safety characteristics are identified by a ( $\Delta$ ) on schematics and on the parts list in this Service Data and its bulletins. Before servicing this instrument, it is important that the service technician read and follow the "Safety Precautions" in the Basic Service Data.

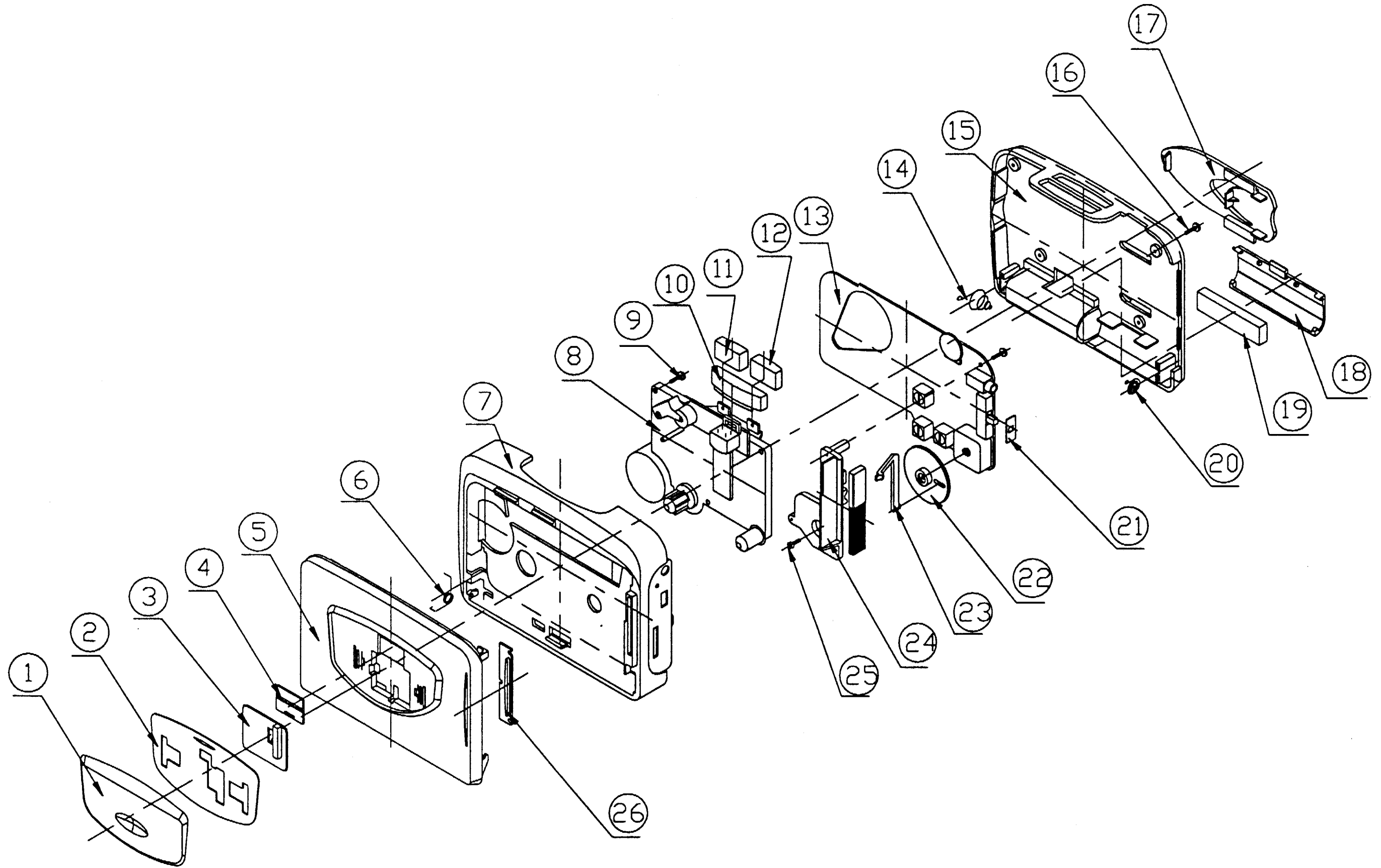

# REPLACEMENT PARTS

**BEFORE REPLACING PARTS, READ THE FOLLOWING:**

Approved Substitute Stock Numbers - Before ordering stock numbers in the part list, look for an approved substitute stock number in the current Price Schedule. This will minimize your service time and avoid ordering parts you already have in stock.

**PRODUCT SAFETY NOTE:** Components marked with a critical safety symbol have special characteristics important to safety. Before replacing any of these components, carefully read the **PRODUCT SAFETY NOTICE** in the basic service data. Do not degrade the safety of the set through improper servicing. Although assemblies as a whole may not be marked with a critical safety symbol, replacement of assemblies with other assemblies not approved may result in a safety hazard.

-  Critical Safety Symbol
- Not Eligible For Warranty

**Warranty Status of Assemblies and Parts - All assemblies and components shown in this part list are eligible for warranty exchange or replacement except those with a dot shown to the left of the Description. Assemblies and components with a dot to the left of the Description are NOT eligible for warranty exchange or replacement.**

**Warranty replacement of cabinet parts requires the approval of a Thomson Consumer Electronics Field Service Manager.**

**Warranty Status and Specifications of assemblies and components are subject to change without notice. Consult the TCE Parts Pricing Microfiche for the latest warranty status information.**

**@NOTE:** When ordering components that are listed more than once in this part list, always adhere to the serial number application guidelines given in the description column. If a serial number application guideline is not given, always select the component with a value, rating, other specification or identification marking(s) that match those of the corresponding component in the instrument you are servicing.

<u>Symbol</u>	<u>Stock</u>	<u>Drawing</u>	<u>Description</u>
---------------	--------------	----------------	--------------------

<u>Symbol</u>	<u>Stock</u>	<u>Drawing</u>	<u>Description</u>
---------------	--------------	----------------	--------------------

**RP-1812A**

**CABINETS ASY**

5	9A32521	521215000RCA01	DOOR CASS
7	98A32522	501215000RCA01	CABINET FRONT
10	43A32523	540008310RCA01	KNOB PLAY
11	43A32524	540005310RCA01	KNOB STOP
12	43A32525	540006310RCA01	KNOB F.FWD
14	3A25648	73000121620	SPRING BATT -
15	98A32526	502215000RCA01	CABINET BACK
17	3A32527	552031000RCA01	CLIP BELT
18	9A32528	522310000RCA01	DOOR BATTERY
22	43A32529	54000121500	KNOB TUNING
23	90A32530	31003121500	POINTER
26	6A32531	53121500000	LENS DIAL

**ELECTRICAL COMPONENTS**

DEC	92A32538	22000700200	DECK CASS
IC1	33A32532	10500211100	IC TA2111F
IC2	33A26769	10500066500	IC LAG665F
JAC	8A32535	1650200500	JACK PHONE STEREO
LED	16A32533	11501221801	LED RED
RES	42A32534	12533500300	RESISTOR VAR VOLUME
SWI	39A32536	17001020215	SWITCH SLIDE 2P2T
SWI	39A32537	17001040305	SWITCH SLIDE 4P3T

**MISCELLANEOUS**

HEA	68A32539	2051301810	HEADPHONE STERRO
LAB	4A32540	POP RP1812	LABEL
USE	UCRP1812	UCRP1812	USE & CARE GUIDE

