

Symbol	Stock	Description	Circuit	Model	Drawing
AC CORD	268258	LINE CORD 3P 1980MM BLK SPT-2	INSTRUMENT	RTD210	VPA105991-0010
AC CORD	266717	LINE CORD 2P 2150MM POLARIZ	INSTRUMENT	RTD210	VPA1K4252-0010
ANT	268252	TRANSMITTER LOOP ANT W/2P 2.5M	INSTRUMENT	RTD210	VTA400002-0010
ANT B	268262	RECEIVER ANT BASE ABS 102.56X2	INSTRUMENT	RTD210	BPH300039-0001
BACK	268274	BACK 500W W/YUV SECC T=0.8MM	INSTRUMENT	RTD210	GSE200116-0201
BOTTOM	268254	BOTTOM CAB SECC T=0.8MM (UL)	INSTRUMENT	RTD210	GSE200115-0101
BOTTOMR	268264	RECEIVER BTM CAB. ABS () FOR U	INSTRUMENT	RTD210	BPB300059-0002
BOX	268272	TRANSMITTER WOOD BOX ASSY	INSTRUMENT	RTD210	ANK500210-CM01
C101	264419	CAP ELECT 100UF 16V 20% 85C	MAIN CBA	RTD210	PRE039540-1010
C102	264419	CAP ELECT 100UF 16V 20% 85C	MAIN CBA	RTD210	PRE039540-1010
C103	264419	CAP ELECT 100UF 16V 20% 85C	MAIN CBA	RTD210	PRE039540-1010
C104	264419	CAP ELECT 100UF 16V 20% 85C	MAIN CBA	RTD210	PRE039540-1010
C105	264442	CHIP CAP 0.1 UF 50V 10%	MAIN CBA	RTD210	PXL456470-1040
C107	264442	CHIP CAP 0.1 UF 50V 10%	MAIN CBA	RTD210	PXL456470-1040
C108	264442	CHIP CAP 0.1 UF 50V 10%	MAIN CBA	RTD210	PXL456470-1040
C110	264442	CHIP CAP 0.1 UF 50V 10%	MAIN CBA	RTD210	PXL456470-1040
C123	264442	CHIP CAP 0.1 UF 50V 10%	MAIN CBA	RTD210	PXL456470-1040
C126	264442	CHIP CAP 0.1 UF 50V 10%	MAIN CBA	RTD210	PXL456470-1040
C129	264442	CHIP CAP 0.1 UF 50V 10%	MAIN CBA	RTD210	PXL456470-1040
C130	264442	CHIP CAP 0.1 UF 50V 10%	MAIN CBA	RTD210	PXL456470-1040
C131	264442	CHIP CAP 0.1 UF 50V 10%	MAIN CBA	RTD210	PXL456470-1040
C132	264442	CHIP CAP 0.1 UF 50V 10%	MAIN CBA	RTD210	PXL456470-1040
C134	264442	CHIP CAP 0.1 UF 50V 10%	MAIN CBA	RTD210	PXL456470-1040
C136	264442	CHIP CAP 0.1 UF 50V 10%	MAIN CBA	RTD210	PXL456470-1040
C151	264419	CAP ELECT 100UF 16V 20% 85C	MAIN CBA	RTD210	PRE039540-1010
C157	266624	D ELECT 10UF 16V 20%	MAIN CBA	RTD210	PRE039540-1000
C160	266624	D ELECT 10UF 16V 20%	MAIN CBA	RTD210	PRE039540-1000
C161	266624	D ELECT 10UF 16V 20%	MAIN CBA	RTD210	PRE039540-1000
C162	266624	D ELECT 10UF 16V 20%	MAIN CBA	RTD210	PRE039540-1000
C163	266624	D ELECT 10UF 16V 20%	MAIN CBA	RTD210	PRE039540-1000
C164	264442	CHIP CAP 0.1 UF 50V 10%	MAIN CBA	RTD210	PXL456470-1040
C186	268204	COND ELECT 4.7 UF 16V 20%	MAIN CBA	RTD210	PRE939540-4790
C188	268232	CHIP CAP 24 PF 50V 5%	MAIN CBA	RTD210	PXL410370-2400
C189	268216	CHIP CAP 1PF 50V +-0.25PF 06	MAIN CBA	RTD210	PXL410870-109Z
C189	268232	CHIP CAP 24 PF 50V 5%	MAIN CBA	RTD210	PXL410370-2400
C196	264331	CHIP CAP 470 PF 50V 5% NPO	MAIN CBA	RTD210	PXL410370-4710
C198	264331	CHIP CAP 470 PF 50V 5% NPO	MAIN CBA	RTD210	PXL410370-4710
C200	264331	CHIP CAP 470 PF 50V 5% NPO	MAIN CBA	RTD210	PXL410370-4710
C202	264331	CHIP CAP 470 PF 50V 5% NPO	MAIN CBA	RTD210	PXL410370-4710

Symbol	Stock	Description	Circuit	Model	Drawing
C214	264321	CHIP CAP 47 PF 50V 5% NPO	MAIN CBA	RTD210	PXL410370-4700
C215	264321	CHIP CAP 47 PF 50V 5% NPO	MAIN CBA	RTD210	PXL410370-4700
C216	264321	CHIP CAP 47 PF 50V 5% NPO	MAIN CBA	RTD210	PXL410370-4700
C219	264442	CHIP CAP 0.1 UF 50V 10%	MAIN CBA	RTD210	PXL456470-1040
C220	264442	CHIP CAP 0.1 UF 50V 10%	MAIN CBA	RTD210	PXL456470-1040
C221	264442	CHIP CAP 0.1 UF 50V 10%	MAIN CBA	RTD210	PXL456470-1040
C222	264442	CHIP CAP 0.1 UF 50V 10%	MAIN CBA	RTD210	PXL456470-1040
C223	264442	CHIP CAP 0.1 UF 50V 10%	MAIN CBA	RTD210	PXL456470-1040
C224	264442	CHIP CAP 0.1 UF 50V 10%	MAIN CBA	RTD210	PXL456470-1040
C225	264442	CHIP CAP 0.1 UF 50V 10%	MAIN CBA	RTD210	PXL456470-1040
C226	264442	CHIP CAP 0.1 UF 50V 10%	MAIN CBA	RTD210	PXL456470-1040
C227	264442	CHIP CAP 0.1 UF 50V 10%	MAIN CBA	RTD210	PXL456470-1040
C228	264442	CHIP CAP 0.1 UF 50V 10%	MAIN CBA	RTD210	PXL456470-1040
C229	264442	CHIP CAP 0.1 UF 50V 10%	MAIN CBA	RTD210	PXL456470-1040
C230	264442	CHIP CAP 0.1 UF 50V 10%	MAIN CBA	RTD210	PXL456470-1040
C231	264442	CHIP CAP 0.1 UF 50V 10%	MAIN CBA	RTD210	PXL456470-1040
C232	264442	CHIP CAP 0.1 UF 50V 10%	MAIN CBA	RTD210	PXL456470-1040
C233	264442	CHIP CAP 0.1 UF 50V 10%	MAIN CBA	RTD210	PXL456470-1040
C234	264442	CHIP CAP 0.1 UF 50V 10%	MAIN CBA	RTD210	PXL456470-1040
C235	264442	CHIP CAP 0.1 UF 50V 10%	MAIN CBA	RTD210	PXL456470-1040
C236	264442	CHIP CAP 0.1 UF 50V 10%	MAIN CBA	RTD210	PXL456470-1040
C237	264442	CHIP CAP 0.1 UF 50V 10%	MAIN CBA	RTD210	PXL456470-1040
C238	264442	CHIP CAP 0.1 UF 50V 10%	MAIN CBA	RTD210	PXL456470-1040
C239	264442	CHIP CAP 0.1 UF 50V 10%	MAIN CBA	RTD210	PXL456470-1040
C240	264442	CHIP CAP 0.1 UF 50V 10%	MAIN CBA	RTD210	PXL456470-1040
C241	264442	CHIP CAP 0.1 UF 50V 10%	MAIN CBA	RTD210	PXL456470-1040
C242	264442	CHIP CAP 0.1 UF 50V 10%	MAIN CBA	RTD210	PXL456470-1040
C243	264442	CHIP CAP 0.1 UF 50V 10%	MAIN CBA	RTD210	PXL456470-1040
C245	264419	CAP ELECT 100UF 16V 20% 85C	MAIN CBA	RTD210	PRE039540-1010
C254	264442	CHIP CAP 0.1 UF 50V 10%	MAIN CBA	RTD210	PXL456470-1040
C259	264321	CHIP CAP 47 PF 50V 5% NPO	MAIN CBA	RTD210	PXL410370-4700
C301	264419	CAP ELECT 100UF 16V 20% 85C	MAIN CBA	RTD210	PRE039540-1010
C302	264419	CAP ELECT 100UF 16V 20% 85C	MAIN CBA	RTD210	PRE039540-1010
C303	266624	D ELECT 10UF 16V 20%	MAIN CBA	RTD210	PRE039540-1000
C304	266624	D ELECT 10UF 16V 20%	MAIN CBA	RTD210	PRE039540-1000
C305	266624	D ELECT 10UF 16V 20%	MAIN CBA	RTD210	PRE039540-1000
C306	266624	D ELECT 10UF 16V 20%	MAIN CBA	RTD210	PRE039540-1000
C310	266624	D ELECT 10UF 16V 20%	MAIN CBA	RTD210	PRE039540-1000
C311	266624	D ELECT 10UF 16V 20%	MAIN CBA	RTD210	PRE039540-1000
C312	266624	D ELECT 10UF 16V 20%	MAIN CBA	RTD210	PRE039540-1000

Symbol	Stock	Description	Circuit	Model	Drawing
C313	266624	D ELECT 10UF 16V 20%	MAIN CBA	RTD210	PRE039540-1000
C314	264419	CAP ELECT 100UF 16V 20% 85C	MAIN CBA	RTD210	PRE039540-1010
C318	268187	COND ELECT 470 UF 16 V 2	MAIN CBA	RTD210	PRE039540-4710
C319	268187	COND ELECT 470 UF 16 V 2	MAIN CBA	RTD210	PRE039540-4710
C320	268187	COND ELECT 470 UF 16 V 2	MAIN CBA	RTD210	PRE039540-4710
C321	268187	COND ELECT 470 UF 16 V 2	MAIN CBA	RTD210	PRE039540-4710
C322	264419	CAP ELECT 100UF 16V 20% 85C	MAIN CBA	RTD210	PRE039540-1010
C323	266624	D ELECT 10UF 16V 20%	MAIN CBA	RTD210	PRE039540-1000
C324	268187	COND ELECT 470 UF 16 V 2	MAIN CBA	RTD210	PRE039540-4710
C325	266624	D ELECT 10UF 16V 20%	MAIN CBA	RTD210	PRE039540-1000
C326	266624	D ELECT 10UF 16V 20%	MAIN CBA	RTD210	PRE039540-1000
C327	268187	COND ELECT 470 UF 16 V 2	MAIN CBA	RTD210	PRE039540-4710
C328	266624	D ELECT 10UF 16V 20%	MAIN CBA	RTD210	PRE039540-1000
C329	264442	CHIP CAP 0.1 UF 50V 10%	MAIN CBA	RTD210	PXL456470-1040
C330	264442	CHIP CAP 0.1 UF 50V 10%	MAIN CBA	RTD210	PXL456470-1040
C331	264442	CHIP CAP 0.1 UF 50V 10%	MAIN CBA	RTD210	PXL456470-1040
C332	264442	CHIP CAP 0.1 UF 50V 10%	MAIN CBA	RTD210	PXL456470-1040
C337	266624	D ELECT 10UF 16V 20%	MAIN CBA	RTD210	PRE039540-1000
C340	264442	CHIP CAP 0.1 UF 50V 10%	MAIN CBA	RTD210	PXL456470-1040
C341	264442	CHIP CAP 0.1 UF 50V 10%	MAIN CBA	RTD210	PXL456470-1040
C342	268187	COND ELECT 470 UF 16 V 2	MAIN CBA	RTD210	PRE039540-4710
C345	264442	CHIP CAP 0.1 UF 50V 10%	MAIN CBA	RTD210	PXL456470-1040
C346	264442	CHIP CAP 0.1 UF 50V 10%	MAIN CBA	RTD210	PXL456470-1040
C347	264442	CHIP CAP 0.1 UF 50V 10%	MAIN CBA	RTD210	PXL456470-1040
C348	264442	CHIP CAP 0.1 UF 50V 10%	MAIN CBA	RTD210	PXL456470-1040
C350	264442	CHIP CAP 0.1 UF 50V 10%	MAIN CBA	RTD210	PXL456470-1040
C351	264442	CHIP CAP 0.1 UF 50V 10%	MAIN CBA	RTD210	PXL456470-1040
C352	264442	CHIP CAP 0.1 UF 50V 10%	MAIN CBA	RTD210	PXL456470-1040
C353	264442	CHIP CAP 0.1 UF 50V 10%	MAIN CBA	RTD210	PXL456470-1040
C354	264442	CHIP CAP 0.1 UF 50V 10%	MAIN CBA	RTD210	PXL456470-1040
C355	264442	CHIP CAP 0.1 UF 50V 10%	MAIN CBA	RTD210	PXL456470-1040
C357	264442	CHIP CAP 0.1 UF 50V 10%	MAIN CBA	RTD210	PXL456470-1040
C358	264442	CHIP CAP 0.1 UF 50V 10%	MAIN CBA	RTD210	PXL456470-1040
C359	264442	CHIP CAP 0.1 UF 50V 10%	MAIN CBA	RTD210	PXL456470-1040
C360	264442	CHIP CAP 0.1 UF 50V 10%	MAIN CBA	RTD210	PXL456470-1040
C361	264442	CHIP CAP 0.1 UF 50V 10%	MAIN CBA	RTD210	PXL456470-1040
C362	264442	CHIP CAP 0.1 UF 50V 10%	MAIN CBA	RTD210	PXL456470-1040
C363	264442	CHIP CAP 0.1 UF 50V 10%	MAIN CBA	RTD210	PXL456470-1040
C364	264442	CHIP CAP 0.1 UF 50V 10%	MAIN CBA	RTD210	PXL456470-1040
C394	266624	D ELECT 10UF 16V 20%	MAIN CBA	RTD210	PRE039540-1000

Symbol	Stock	Description	Circuit	Model	Drawing
C395	266624	D ELECT 10UF 16V 20%	MAIN CBA	RTD210	PRE039540-1000
C398	264419	CAP ELECT 100UF 16V 20% 85C	MAIN CBA	RTD210	PRE039540-1010
C399	264419	CAP ELECT 100UF 16V 20% 85C	MAIN CBA	RTD210	PRE039540-1010
C400	264419	CAP ELECT 100UF 16V 20% 85C	MAIN CBA	RTD210	PRE039540-1010
C401	264419	CAP ELECT 100UF 16V 20% 85C	MAIN CBA	RTD210	PRE039540-1010
C402	264419	CAP ELECT 100UF 16V 20% 85C	MAIN CBA	RTD210	PRE039540-1010
C403	264320	CHIP CAP 33 PF 50V 5% NPO	MAIN CBA	RTD210	PXL410370-3300
C404	268187	COND ELECT 470 UF 16 V 2	MAIN CBA	RTD210	PRE039540-4710
C408	264442	CHIP CAP 0.1 UF 50V 10%	MAIN CBA	RTD210	PXL456470-1040
C409	264442	CHIP CAP 0.1 UF 50V 10%	MAIN CBA	RTD210	PXL456470-1040
C410	264442	CHIP CAP 0.1 UF 50V 10%	MAIN CBA	RTD210	PXL456470-1040
C411	264421	CAP ELECT 220 UF 16V 20% 85C	MAIN CBA	RTD210	PRE039540-2210
C412	264421	CAP ELECT 220 UF 16V 20% 85C	MAIN CBA	RTD210	PRE039540-2210
C420	264442	CHIP CAP 0.1 UF 50V 10%	MAIN CBA	RTD210	PXL456470-1040
C421	268204	COND ELECT 4.7 UF 16V 20%	MAIN CBA	RTD210	PRE939540-4790
C427	264442	CHIP CAP 0.1 UF 50V 10%	MAIN CBA	RTD210	PXL456470-1040
C434	264320	CHIP CAP 33 PF 50V 5% NPO	MAIN CBA	RTD210	PXL410370-3300
C435	264320	CHIP CAP 33 PF 50V 5% NPO	MAIN CBA	RTD210	PXL410370-3300
C436	264320	CHIP CAP 33 PF 50V 5% NPO	MAIN CBA	RTD210	PXL410370-3300
C437	264320	CHIP CAP 33 PF 50V 5% NPO	MAIN CBA	RTD210	PXL410370-3300
C438	264320	CHIP CAP 33 PF 50V 5% NPO	MAIN CBA	RTD210	PXL410370-3300
C439	264320	CHIP CAP 33 PF 50V 5% NPO	MAIN CBA	RTD210	PXL410370-3300
C440	264320	CHIP CAP 33 PF 50V 5% NPO	MAIN CBA	RTD210	PXL410370-3300
C441	264320	CHIP CAP 33 PF 50V 5% NPO	MAIN CBA	RTD210	PXL410370-3300
C442	264320	CHIP CAP 33 PF 50V 5% NPO	MAIN CBA	RTD210	PXL410370-3300
C443	264320	CHIP CAP 33 PF 50V 5% NPO	MAIN CBA	RTD210	PXL410370-3300
C444	264320	CHIP CAP 33 PF 50V 5% NPO	MAIN CBA	RTD210	PXL410370-3300
C445	264320	CHIP CAP 33 PF 50V 5% NPO	MAIN CBA	RTD210	PXL410370-3300
C446	264320	CHIP CAP 33 PF 50V 5% NPO	MAIN CBA	RTD210	PXL410370-3300
C447	264320	CHIP CAP 33 PF 50V 5% NPO	MAIN CBA	RTD210	PXL410370-3300
C448	264320	CHIP CAP 33 PF 50V 5% NPO	MAIN CBA	RTD210	PXL410370-3300
C449	264320	CHIP CAP 33 PF 50V 5% NPO	MAIN CBA	RTD210	PXL410370-3300
C450	264320	CHIP CAP 33 PF 50V 5% NPO	MAIN CBA	RTD210	PXL410370-3300
C451	264320	CHIP CAP 33 PF 50V 5% NPO	MAIN CBA	RTD210	PXL410370-3300
C461	264419	CAP ELECT 100UF 16V 20% 85C	MAIN CBA	RTD210	PRE039540-1010
C462	264419	CAP ELECT 100UF 16V 20% 85C	MAIN CBA	RTD210	PRE039540-1010
C463	264442	CHIP CAP 0.1 UF 50V 10%	MAIN CBA	RTD210	PXL456470-1040
C464	264442	CHIP CAP 0.1 UF 50V 10%	MAIN CBA	RTD210	PXL456470-1040
C465	264442	CHIP CAP 0.1 UF 50V 10%	MAIN CBA	RTD210	PXL456470-1040
C466	264442	CHIP CAP 0.1 UF 50V 10%	MAIN CBA	RTD210	PXL456470-1040

Symbol	Stock	Description	Circuit	Model	Drawing
C467	264442	CHIP CAP 0.1 UF 50V 10%	MAIN CBA	RTD210	PXL456470-1040
C468	264442	CHIP CAP 0.1 UF 50V 10%	MAIN CBA	RTD210	PXL456470-1040
C469	264442	CHIP CAP 0.1 UF 50V 10%	MAIN CBA	RTD210	PXL456470-1040
C470	264442	CHIP CAP 0.1 UF 50V 10%	MAIN CBA	RTD210	PXL456470-1040
C471	264442	CHIP CAP 0.1 UF 50V 10%	MAIN CBA	RTD210	PXL456470-1040
C472	264442	CHIP CAP 0.1 UF 50V 10%	MAIN CBA	RTD210	PXL456470-1040
C473	264442	CHIP CAP 0.1 UF 50V 10%	MAIN CBA	RTD210	PXL456470-1040
C474	264442	CHIP CAP 0.1 UF 50V 10%	MAIN CBA	RTD210	PXL456470-1040
C475	264442	CHIP CAP 0.1 UF 50V 10%	MAIN CBA	RTD210	PXL456470-1040
C476	264442	CHIP CAP 0.1 UF 50V 10%	MAIN CBA	RTD210	PXL456470-1040
C477	264442	CHIP CAP 0.1 UF 50V 10%	MAIN CBA	RTD210	PXL456470-1040
C478	264442	CHIP CAP 0.1 UF 50V 10%	MAIN CBA	RTD210	PXL456470-1040
C479	264442	CHIP CAP 0.1 UF 50V 10%	MAIN CBA	RTD210	PXL456470-1040
C480	264442	CHIP CAP 0.1 UF 50V 10%	MAIN CBA	RTD210	PXL456470-1040
C481	264442	CHIP CAP 0.1 UF 50V 10%	MAIN CBA	RTD210	PXL456470-1040
C502	264442	CHIP CAP 0.1 UF 50V 10%	MAIN CBA	RTD210	PXL456470-1040
C504	264442	CHIP CAP 0.1 UF 50V 10%	MAIN CBA	RTD210	PXL456470-1040
C506	264442	CHIP CAP 0.1 UF 50V 10%	MAIN CBA	RTD210	PXL456470-1040
C508	264442	CHIP CAP 0.1 UF 50V 10%	MAIN CBA	RTD210	PXL456470-1040
C510	264442	CHIP CAP 0.1 UF 50V 10%	MAIN CBA	RTD210	PXL456470-1040
C512	264442	CHIP CAP 0.1 UF 50V 10%	MAIN CBA	RTD210	PXL456470-1040
C515	264442	CHIP CAP 0.1 UF 50V 10%	MAIN CBA	RTD210	PXL456470-1040
C516	264442	CHIP CAP 0.1 UF 50V 10%	MAIN CBA	RTD210	PXL456470-1040
C522	266624	D ELECT 10UF 16V 20%	MAIN CBA	RTD210	PRE039540-1000
C523	266624	D ELECT 10UF 16V 20%	MAIN CBA	RTD210	PRE039540-1000
C524	264419	CAP ELECT 100UF 16V 20% 85C	MAIN CBA	RTD210	PRE039540-1010
C543	264441	CHIP CAP 0.01 UF 50V 10%	MAIN CBA	RTD210	PXL456470-1030
C544	264441	CHIP CAP 0.01 UF 50V 10%	MAIN CBA	RTD210	PXL456470-1030
C545	264441	CHIP CAP 0.01 UF 50V 10%	MAIN CBA	RTD210	PXL456470-1030
C546	264441	CHIP CAP 0.01 UF 50V 10%	MAIN CBA	RTD210	PXL456470-1030
C547	264441	CHIP CAP 0.01 UF 50V 10%	MAIN CBA	RTD210	PXL456470-1030
C548	264441	CHIP CAP 0.01 UF 50V 10%	MAIN CBA	RTD210	PXL456470-1030
C549	264441	CHIP CAP 0.01 UF 50V 10%	MAIN CBA	RTD210	PXL456470-1030
C550	264441	CHIP CAP 0.01 UF 50V 10%	MAIN CBA	RTD210	PXL456470-1030
C551	268215	CHIP CAP 0.1UF/100V X7R +/-10%	MAIN CBA	RTD210	PZL4564A4-1040
C552	268215	CHIP CAP 0.1UF/100V X7R +/-10%	MAIN CBA	RTD210	PZL4564A4-1040
C553	268203	COND METAL 0.68UF 100V 5%	MAIN CBA	RTD210	PEN1263A0-684Z
C554	268215	CHIP CAP 0.1UF/100V X7R +/-10%	MAIN CBA	RTD210	PZL4564A4-1040
C555	268215	CHIP CAP 0.1UF/100V X7R +/-10%	MAIN CBA	RTD210	PZL4564A4-1040
C556	268215	CHIP CAP 0.1UF/100V X7R +/-10%	MAIN CBA	RTD210	PZL4564A4-1040

Symbol	Stock	Description	Circuit	Model	Drawing
C557	268203	COND METAL 0.68UF 100V 5%	MAIN CBA	RTD210	PEN1263A0-684Z
C558	268215	CHIP CAP 0.1UF/100V X7R +/-10%	MAIN CBA	RTD210	PZL4564A4-1040
C559	268215	CHIP CAP 0.1UF/100V X7R +/-10%	MAIN CBA	RTD210	PZL4564A4-1040
C560	264419	CAP ELECT 100UF 16V 20% 85C	MAIN CBA	RTD210	PRE039540-1010
C561	268215	CHIP CAP 0.1UF/100V X7R +/-10%	MAIN CBA	RTD210	PZL4564A4-1040
C564	268215	CHIP CAP 0.1UF/100V X7R +/-10%	MAIN CBA	RTD210	PZL4564A4-1040
C565	268215	CHIP CAP 0.1UF/100V X7R +/-10%	MAIN CBA	RTD210	PZL4564A4-1040
C570	268215	CHIP CAP 0.1UF/100V X7R +/-10%	MAIN CBA	RTD210	PZL4564A4-1040
C571	268215	CHIP CAP 0.1UF/100V X7R +/-10%	MAIN CBA	RTD210	PZL4564A4-1040
C578	264432	CAP ELECT 1000UF 50V 20% 85C	MAIN CBA	RTD210	PDE039570-1020
C579	264432	CAP ELECT 1000UF 50V 20% 85C	MAIN CBA	RTD210	PDE039570-1020
C580	264432	CAP ELECT 1000UF 50V 20% 85C	MAIN CBA	RTD210	PDE039570-1020
C587	268203	COND METAL 0.68UF 100V 5%	MAIN CBA	RTD210	PEN1263A0-684Z
C588	268203	COND METAL 0.68UF 100V 5%	MAIN CBA	RTD210	PEN1263A0-684Z
C589	266624	D ELECT 10UF 16V 20%	MAIN CBA	RTD210	PRE039540-1000
C592	264432	CAP ELECT 1000UF 50V 20% 85C	MAIN CBA	RTD210	PDE039570-1020
C593	268187	COND ELECT 470 UF 16 V 2	MAIN CBA	RTD210	PRE039540-4710
C594	268187	COND ELECT 470 UF 16 V 2	MAIN CBA	RTD210	PRE039540-4710
C595	268187	COND ELECT 470 UF 16 V 2	MAIN CBA	RTD210	PRE039540-4710
C701	264323	CHIP CAP 100 PF 50V 5% NPO	MAIN CBA	RTD210	PXL410370-1010
C702	264323	CHIP CAP 100 PF 50V 5% NPO	MAIN CBA	RTD210	PXL410370-1010
C703	264442	CHIP CAP 0.1 UF 50V 10%	MAIN CBA	RTD210	PXL456470-1040
C704	264442	CHIP CAP 0.1 UF 50V 10%	MAIN CBA	RTD210	PXL456470-1040
C705	264442	CHIP CAP 0.1 UF 50V 10%	MAIN CBA	RTD210	PXL456470-1040
C706	264442	CHIP CAP 0.1 UF 50V 10%	MAIN CBA	RTD210	PXL456470-1040
C707	264442	CHIP CAP 0.1 UF 50V 10%	MAIN CBA	RTD210	PXL456470-1040
C708	268222	COND ELECT 10UF 50V 20% P=5.0	MAIN CBA	RTD210	PRE839570-1000
C709	268223	COND ELECT 100UF 16V 20% 85C M	MAIN CBA	RTD210	PRE839540-1010
C710	268223	COND ELECT 100UF 16V 20% 85C M	MAIN CBA	RTD210	PRE839540-1010
C711	268223	COND ELECT 100UF 16V 20% 85C M	MAIN CBA	RTD210	PRE839540-1010
C712	264329	CHIP CAP 220 PF 50V 5% NPO	MAIN CBA	RTD210	PXL410370-2210
C713	264376	CHIP CAP 15 PF 50V 5%	MAIN CBA	RTD210	PXL410370-1500
C714	264376	CHIP CAP 15 PF 50V 5%	MAIN CBA	RTD210	PXL410370-1500
C715	264376	CHIP CAP 15 PF 50V 5%	MAIN CBA	RTD210	PXL410370-1500
C716	264318	CHIP CAP 22 PF 50V 5%	MAIN CBA	RTD210	PXL410370-2200
C717	264318	CHIP CAP 22 PF 50V 5%	MAIN CBA	RTD210	PXL410370-2200
C721	268222	COND ELECT 10UF 50V 20% P=5.0	MAIN CBA	RTD210	PRE839570-1000
C801	264376	CHIP CAP 15 PF 50V 5%	MAIN CBA	RTD210	PXL410370-1500
C802	264376	CHIP CAP 15 PF 50V 5%	MAIN CBA	RTD210	PXL410370-1500
C803	264376	CHIP CAP 15 PF 50V 5%	MAIN CBA	RTD210	PXL410370-1500

Symbol	Stock	Description	Circuit	Model	Drawing
CABLE	266705	CABLE 24PIN 180MM	INSTRUMENT	RTD210	VFC240110-1800
CABLE	268249	TRANSMITTER COAXIAL CABLE 1P 9	INSTRUMENT	RTD210	VHW117AAA-0090
CABLE	268251	TRANSMITTER FLAT CABLE 7P 300M	INSTRUMENT	RTD210	VFL7K1246-3000
CABLE	266718	RCA CABLE 1500MM OD2.6MM BLK	INSTRUMENT	RTD210	VRC101008-0020
CABLE	268265	RECEIVER COAXIAL CABLE 1P 50MM	INSTRUMENT	RTD210	VHW117AAA-0050
CABLE	268266	RECEIVER CON/WIRE 3P 180MM 161	INSTRUMENT	RTD210	VWA311014-0057
CABLE1	266715	CON/WIRE 5PIN 260MM	INSTRUMENT	RTD210	VFL501244-2600
CABLE2	266716	WIRE 6PIN 220MM	INSTRUMENT	RTD210	VFL601244-2200
CABLE3	266704	CABLE 13PIN 120MM	INSTRUMENT	RTD210	VFC130330-1200
CN102	266654	CONNECTOR 6 PIN PITCH=2.0MM	MAIN CBA	RTD210	CCN200000-0106
CN103	264245	CONNECTOR 5 PIN PITCH=2.0MM	MAIN CBA	RTD210	CCN200000-0105
CN104	266636	WIRE 4PIN 50MM	MAIN CBA	RTD210	VFL401245-0500
CN302	266637	WIRE 7PIN 80MM	MAIN CBA	RTD210	VFL704312-0800
CN303	264243	CONNECTOR 3 PIN PITCH=2.0MM	MAIN CBA	RTD210	CCN200000-0103
CN304	266638	WIRE 4PIN 80MM	MAIN CBA	RTD210	VWA310060-0001
CN305	264248	CONNECTOR 8 PIN PITCH=2.0MM	MAIN CBA	RTD210	CCN200000-0108
CN306	266655	CONNECTOR 13P P1.25X2XH8MM 180	MAIN CBA	RTD210	CCH125030-2213
CN501	264431	CONNECTOR B2B-XH-A 2 PIN	MAIN CBA	RTD210	CCN250000-0102
D101	264339	DIODE CHIP BAV16W/IN4148W	MAIN CBA	RTD210	RCD114148-0011
D102	264339	DIODE CHIP BAV16W/IN4148W	MAIN CBA	RTD210	RCD114148-0011
D103	264339	DIODE CHIP BAV16W/IN4148W	MAIN CBA	RTD210	RCD114148-0011
D301	264339	DIODE CHIP BAV16W/IN4148W	MAIN CBA	RTD210	RCD114148-0011
D302	264339	DIODE CHIP BAV16W/IN4148W	MAIN CBA	RTD210	RCD114148-0011
D303	264339	DIODE CHIP BAV16W/IN4148W	MAIN CBA	RTD210	RCD114148-0011
D501	264339	DIODE CHIP BAV16W/IN4148W	MAIN CBA	RTD210	RCD114148-0011
D502	264339	DIODE CHIP BAV16W/IN4148W	MAIN CBA	RTD210	RCD114148-0011
D701	264339	DIODE CHIP BAV16W/IN4148W	MAIN CBA	RTD210	RCD114148-0011
D702	264339	DIODE CHIP BAV16W/IN4148W	MAIN CBA	RTD210	RCD114148-0011
D703	264339	DIODE CHIP BAV16W/IN4148W	MAIN CBA	RTD210	RCD114148-0011
DOOR	266713	DOOR	INSTRUMENT	RTD210	BPD200022-0001
DOOR	268268	RECEIVER ID SW DOOR ABS 21.5X1	INSTRUMENT	RTD210	BPD300021-0001
DP701	266625	FLOUR.DISPL SM51T SAMSUNG	MAIN CBA	RTD210	KLV000034-0010
DR LENS	268236	DOOR LENS ARCYLIC	INSTRUMENT	RTD210	BPN200043-0004
DR401	264355	IC 8PIN TEXAS RC4558D SOP8	MAIN CBA	RTD210	RCI004558-0003
DR420	264355	IC 8PIN TEXAS RC4558D SOP8	MAIN CBA	RTD210	RCI004558-0003
DR610	264355	IC 8PIN TEXAS RC4558D SOP8	MAIN CBA	RTD210	RCI004558-0003
DR620	264355	IC 8PIN TEXAS RC4558D SOP8	MAIN CBA	RTD210	RCI004558-0003
DSPLENS	268275	DISPLAY LENS ARCYLIC	INSTRUMENT	RTD210	BPN200042-0002
DVDMEC	266621	DVD MECHANISM	INSTRUMENT	RTD210	ASL261603-1102
F BRACK	266686	FAN BRACKET	INSTRUMENT	RTD210	BPH200018-0001

Symbol	Stock	Description	Circuit	Model	Drawing
F KNOB	266687	FUNCTION KNOB	INSTRUMENT	RTD210	BPK208036-0001
F PANEL	268256	FRONT CAB HIPS 94V0	INSTRUMENT	RTD210	BPF200036-0202
FAN	266697	DC FAN 12V 70MA KD1205PFS	INSTRUMENT	RTD210	FAN021203-0004
FB102	264343	CHIP BEAD 600 OHM AT 100MHZ	MAIN CBA	RTD210	SCB008050-6010
FB103	264343	CHIP BEAD 600 OHM AT 100MHZ	MAIN CBA	RTD210	SCB008050-6010
FB115	264343	CHIP BEAD 600 OHM AT 100MHZ	MAIN CBA	RTD210	SCB008050-6010
FB116	264343	CHIP BEAD 600 OHM AT 100MHZ	MAIN CBA	RTD210	SCB008050-6010
FB117	264343	CHIP BEAD 600 OHM AT 100MHZ	MAIN CBA	RTD210	SCB008050-6010
FB118	264343	CHIP BEAD 600 OHM AT 100MHZ	MAIN CBA	RTD210	SCB008050-6010
FB301	264343	CHIP BEAD 600 OHM AT 100MHZ	MAIN CBA	RTD210	SCB008050-6010
FB302	264343	CHIP BEAD 600 OHM AT 100MHZ	MAIN CBA	RTD210	SCB008050-6010
FB304	264343	CHIP BEAD 600 OHM AT 100MHZ	MAIN CBA	RTD210	SCB008050-6010
FB306	264343	CHIP BEAD 600 OHM AT 100MHZ	MAIN CBA	RTD210	SCB008050-6010
FB307	264343	CHIP BEAD 600 OHM AT 100MHZ	MAIN CBA	RTD210	SCB008050-6010
FB308	264343	CHIP BEAD 600 OHM AT 100MHZ	MAIN CBA	RTD210	SCB008050-6010
FB309	264343	CHIP BEAD 600 OHM AT 100MHZ	MAIN CBA	RTD210	SCB008050-6010
FB310	264401	BEAD FERIT DIA3.5X6MM 100 OHM	MAIN CBA	RTD210	SFB001001-0030
FB311	264401	BEAD FERIT DIA3.5X6MM 100 OHM	MAIN CBA	RTD210	SFB001001-0030
FB312	264401	BEAD FERIT DIA3.5X6MM 100 OHM	MAIN CBA	RTD210	SFB001001-0030
FB313	264401	BEAD FERIT DIA3.5X6MM 100 OHM	MAIN CBA	RTD210	SFB001001-0030
FB314	264401	BEAD FERIT DIA3.5X6MM 100 OHM	MAIN CBA	RTD210	SFB001001-0030
FB315	264401	BEAD FERIT DIA3.5X6MM 100 OHM	MAIN CBA	RTD210	SFB001001-0030
FB316	264401	BEAD FERIT DIA3.5X6MM 100 OHM	MAIN CBA	RTD210	SFB001001-0030
FB317	264401	BEAD FERIT DIA3.5X6MM 100 OHM	MAIN CBA	RTD210	SFB001001-0030
FB318	264401	BEAD FERIT DIA3.5X6MM 100 OHM	MAIN CBA	RTD210	SFB001001-0030
FB319	266708	SMD BEAD 100 OHM AT 100MHZ	MAIN CBA	RTD210	SCB008050-1010
FB320	266708	SMD BEAD 100 OHM AT 100MHZ	MAIN CBA	RTD210	SCB008050-1010
FB321	266708	SMD BEAD 100 OHM AT 100MHZ	MAIN CBA	RTD210	SCB008050-1010
FB322	264343	CHIP BEAD 600 OHM AT 100MHZ	MAIN CBA	RTD210	SCB008050-6010
FB323	264343	CHIP BEAD 600 OHM AT 100MHZ	MAIN CBA	RTD210	SCB008050-6010
FB324	264343	CHIP BEAD 600 OHM AT 100MHZ	MAIN CBA	RTD210	SCB008050-6010
FB325	266708	SMD BEAD 100 OHM AT 100MHZ	MAIN CBA	RTD210	SCB008050-1010
FB326	266708	SMD BEAD 100 OHM AT 100MHZ	MAIN CBA	RTD210	SCB008050-1010
FB327	264401	BEAD FERIT DIA3.5X6MM 100 OHM	MAIN CBA	RTD210	SFB001001-0030
FB501	264343	CHIP BEAD 600 OHM AT 100MHZ	MAIN CBA	RTD210	SCB008050-6010
FB502	264343	CHIP BEAD 600 OHM AT 100MHZ	MAIN CBA	RTD210	SCB008050-6010
FB801	264343	CHIP BEAD 600 OHM AT 100MHZ	MAIN CBA	RTD210	SCB008050-6010
FB802	264343	CHIP BEAD 600 OHM AT 100MHZ	MAIN CBA	RTD210	SCB008050-6010
FB803	264343	CHIP BEAD 600 OHM AT 100MHZ	MAIN CBA	RTD210	SCB008050-6010
FM ANT	268255	FM ANTENNA 1600 MM 75 OHM MALE	INSTRUMENT	RTD210	VTA400001-1060



Symbol	Stock	Description	Circuit	Model	Drawing
FNT BRK	266700	FRONT BRACKET	INSTRUMENT	RTD210	GSE200117-0001
FOOT	268267	RECEIVER FOOT RUBBER DIA15.9XH	INSTRUMENT	RTD210	DUF003006-0001
HOLDER	268269	RECEIVER ID SW HOLDER SECC T=1	INSTRUMENT	RTD210	GSE300139-0001
IC101	266673	IC 28 PIN AM5868S	MAIN CBA	RTD210	RCI005868-0002
IC102	266674	IC 64 PIN ES6603S LQFP	MAIN CBA	RTD210	RCI006603-0001
IC103	268197	IC 8 PIN 24LLC02A SOP CERAMATE	MAIN CBA	RTD210	RCI240002-0005
IC103	264349	IC 8 PIN AT24C02N-10SI-2.7	MAIN CBA	RTD210	RCI024002-0002
IC103	268198	IC 8 PIN SSC24A02 SOP CERAMATE	MAIN CBA	RTD210	RCI024002-0004
IC104	268194	IC 54 PIN HY57V641620HGT-6 4	MAIN CBA	RTD210	RCI641620-0001
IC104	268195	IC 54 PIN HY57V641620HGT-55 1	MAIN CBA	RTD210	RCI641620-0002
IC104	268196	IC 54.PIN K4S641632H-TC 75	MAIN CBA	RTD210	RCI641632-0001
IC105	268191	IC 3P CM3403-29ST 2.93V SOT-22	MAIN CBA	RTD210	RCI003403-0001
IC105	264368	IC 3 PIN IMP809SEUR-T SOT23	MAIN CBA	RTD210	RCI000809-0003
IC106	268190	IC 208 PIN ES6698FD PQFP W/DTS	MAIN CBA	RTD210	RCI006698-0002
IC107	268199	IC 48 PIN MX29LV160ABTC-70 MXI	MAIN CBA	RTD210	AIC290160-C416
IC108	264350	IC 20 PIN 74HC374	MAIN CBA	RTD210	RCI740374-0002
IC109	264350	IC 20 PIN 74HC374	MAIN CBA	RTD210	RCI740374-0002
IC111	268193	IC 14 PIN TC74HC04AFN TOSHIBA	MAIN CBA	RTD210	RCI740004-0001
IC301	268218	IC 3 PIN AN7806 MATSUSHITA	MAIN CBA	RTD210	RHI007806-0001
IC302	268189	IC 16P CS5342-CZZ TSSOP CIRRUS	MAIN CBA	RTD210	RCI005342-1001
IC303	268208	IC 8 PIN CO4558A SOP8 CERAM	MAIN CBA	RTD210	RCI004558-0102
IC304	268208	IC 8 PIN CO4558A SOP8 CERAM	MAIN CBA	RTD210	RCI004558-0102
IC307	268188	IC 8 PIN APA3541 SOP-8 HEADPH	MAIN CBA	RTD210	RCI003541-0001
IC308	264354	IC 16 PIN TC4052BFN CHIP	MAIN CBA	RTD210	RCI004052-0001
IC308	268207	IC 16 PIN CD4052BM SOIC TI	MAIN CBA	RTD210	RCI004052-0002
IC310	264363	IC 3 PIN RT9164-33CLR	MAIN CBA	RTD210	RCI916433-0001
IC311	264363	IC 3 PIN RT9164-33CLR	MAIN CBA	RTD210	RCI916433-0001
IC312	268205	IC 3 PIN LD1117 ADJ SOT223 ST	MAIN CBA	RTD210	RCI111700-0201
IC501	266668	IC 64 PIN STA308A TQFP ST	MAIN CBA	RTD210	RCI000308-0002
IC502	268192	IC 36 PIN STA506 SO ST 60WX2	MAIN CBA	RTD210	RCI000506-0001
IC503	268192	IC 36 PIN STA506 SO ST 60WX2	MAIN CBA	RTD210	RCI000506-0001
IC504	268192	IC 36 PIN STA506 SO ST 60WX2	MAIN CBA	RTD210	RCI000506-0001
IC701	266669	IC 18 PIN CTM8B56EP SOP	MAIN CBA	RTD210	RCI008056-0001
IC702	264443	IC 52 PIN PT6311(PTC)	MAIN CBA	RTD210	RCI006311-0001
JK103	264428	JACK RCA YEL = S-VIDEO	MAIN CBA	RTD210	CJC010004-3030
JK104	268217	OPTICAL RECEIVER DLR1111	MAIN CBA	RTD210	CJT200001-0005
JK301	268227	TEL.JACK 8P8C RJ-45	MAIN CBA	RTD210	CJE100002-0001
JK303	264246	RCA JACK 4P WHT-WHT/RED-RED	MAIN CBA	RTD210	CJR104101-0010
JK501	268228	SPK JACK 8P RD-WT-GRN-PUL/BKX4	MAIN CBA	RTD210	CJS008101-0050
JK701	268213	PHONE JACK D3.5 5P NATURAL COL	MAIN CBA	RTD210	CJM035006-3010

Symbol	Stock	Description	Circuit	Model	Drawing
JK801	264436	RCA JACK 3P RED/BLU/GRN AXIA	MAIN CBA	RTD210	CJR003301-0020
JP101	268202	WIRE BARE 22 GA TINNED	MAIN CBA	RTD210	XJP220000-0001
JP102	268202	WIRE BARE 22 GA TINNED	MAIN CBA	RTD210	XJP220000-0001
JP103	268202	WIRE BARE 22 GA TINNED	MAIN CBA	RTD210	XJP220000-0001
JP104	268202	WIRE BARE 22 GA TINNED	MAIN CBA	RTD210	XJP220000-0001
JP105	268202	WIRE BARE 22 GA TINNED	MAIN CBA	RTD210	XJP220000-0001
JP106	268202	WIRE BARE 22 GA TINNED	MAIN CBA	RTD210	XJP220000-0001
L CAB	268257	LEFT CAB HIPS 94V0	INSTRUMENT	RTD210	BPS201002-0002
L102	268201	INDUCTOR 2.4 UH 10% AI	MAIN CBA	RTD210	SAN001600-2490
L104	266671	INDUC 2.4 UH 5% SMD 0805	MAIN CBA	RTD210	SCN023500-2490
L105	266671	INDUC 2.4 UH 5% SMD 0805	MAIN CBA	RTD210	SCN023500-2490
L106	266671	INDUC 2.4 UH 5% SMD 0805	MAIN CBA	RTD210	SCN023500-2490
L107	266671	INDUC 2.4 UH 5% SMD 0805	MAIN CBA	RTD210	SCN023500-2490
L108	266671	INDUC 2.4 UH 5% SMD 0805	MAIN CBA	RTD210	SCN023500-2490
L301	264342	CHIP INDUC 10 UH 10% SMD 0805	MAIN CBA	RTD210	SCN023600-1000
L302	264342	CHIP INDUC 10 UH 10% SMD 0805	MAIN CBA	RTD210	SCN023600-1000
L501	268229	INDUCTOR 10 UH 20% 8.5TS 2UEW	MAIN CBA	RTD210	SIN002701-1000
L502	268229	INDUCTOR 10 UH 20% 8.5TS 2UEW	MAIN CBA	RTD210	SIN002701-1000
L503	268229	INDUCTOR 10 UH 20% 8.5TS 2UEW	MAIN CBA	RTD210	SIN002701-1000
L504	268229	INDUCTOR 10 UH 20% 8.5TS 2UEW	MAIN CBA	RTD210	SIN002701-1000
L505	268231	COMMON MODE COIL 27UH 4P GOLD	MAIN CBA	RTD210	SIL217001-2700
L506	264240	COIL 20UH D0.5MM 4PIN	MAIN CBA	RTD210	SIL102001-2000
L507	268231	COMMON MODE COIL 27UH 4P GOLD	MAIN CBA	RTD210	SIL217001-2700
L508	264240	COIL 20UH D0.5MM 4PIN	MAIN CBA	RTD210	SIL102001-2000
L509	268230	INDUCTOR 15UH 20% 11.5TS 2UEW	MAIN CBA	RTD210	SIN002701-1500
L510	268230	INDUCTOR 15UH 20% 11.5TS 2UEW	MAIN CBA	RTD210	SIN002701-1500
L511	268230	INDUCTOR 15UH 20% 11.5TS 2UEW	MAIN CBA	RTD210	SIN002701-1500
L512	268230	INDUCTOR 15UH 20% 11.5TS 2UEW	MAIN CBA	RTD210	SIN002701-1500
LCOVERR	268270	RECEIVER L-COVER ABS () FOR UL	INSTRUMENT	RTD210	BPV300014-0002
LD701	266651	3 DIA RED ROUND LEAD 10MM	MAIN CBA	RTD210	KED200003-2010
LENS	268237	RECEIVER LENS LEFT PC 88.5X5.5	INSTRUMENT	RTD210	BPN300051-0001
LENS	268238	RECEIVER LENS MIDDLE PC 50X5.5	INSTRUMENT	RTD210	BPN300053-0001
LOAD BR	266701	LOADER BRACKET	INSTRUMENT	RTD210	GSE200118-0001
MAGNET	268253	TRANSMITTER MAGNET	INSTRUMENT	RTD210	GMA500001-0001
P KNOB	266689	POWER KNOB	INSTRUMENT	RTD210	BPK218036-0001
P TRAN	268239	RECEIVER POWER TRANS 120V 60HZ	INSTRUMENT	RTD210	TTI312010-0017
P TRANS2	268240	RECEIVER POWER TRANS 120V 60HZ	INSTRUMENT	RTD210	TTI312010-0012
PCB010	268259	MAIN PCB ASSY	INSTRUMENT	RTD210	APE200690-0002
PCB011	268235	CONTROL PCB ASSY	INSTRUMENT	RTD210	APE201461-0003
PCB012	268226	STANDBY PCB ASSY	MAIN CBA	RTD210	APE201462-0002

Symbol	Stock	Description	Circuit	Model	Drawing
PCB012	268261	POWER SUPPLY 8 O/P 360W PS-835	INSTRUMENT	RTD210	TPS280360-0001
PCB013	266657	YUV PCB ASSY	INSTRUMENT	RTD210	APE200740-0001
PTRANS	268239	RECEIVER POWER TRANS 120V 60HZ	INSTRUMENT	RTD210	TTI312010-0017
PW LENS	268260	POWER KEY LENS	INSTRUMENT	RTD210	BPN210044-0004
Q101	266652	FET 2SK3018 30V/0.1A SC-70 ROH	MAIN CBA	RTD210	RCM203018-1001
Q102	266652	FET 2SK3018 30V/0.1A SC-70 ROH	MAIN CBA	RTD210	RCM203018-1001
Q103	264346	XISTR NPN CM5783GR SOT23	MAIN CBA	RTD210	RCN005783-0001
Q104	264346	XISTR NPN CM5783GR SOT23	MAIN CBA	RTD210	RCN005783-0001
Q105	268206	XISTR PNP 2SB1132RT100 ROHM HF	MAIN CBA	RTD210	RCP201132-0003
Q105	266653	TR XISTR PNP 2SB1132-T100	MAIN CBA	RTD210	RCP201132-0001
Q106	268206	XISTR PNP 2SB1132RT100 ROHM HF	MAIN CBA	RTD210	RCP201132-0003
Q106	266653	TR XISTR PNP 2SB1132-T100	MAIN CBA	RTD210	RCP201132-0001
Q107	264344	XISTR PNP 2SA812 HFE:200~400	MAIN CBA	RTD210	RCP200733-0001
Q302	264346	XISTR NPN CM5783GR SOT23	MAIN CBA	RTD210	RCN005783-0001
Q304	264344	XISTR PNP 2SA812 HFE:200~400	MAIN CBA	RTD210	RCP200733-0001
Q305	264346	XISTR NPN CM5783GR SOT23	MAIN CBA	RTD210	RCN005783-0001
Q306	264346	XISTR NPN CM5783GR SOT23	MAIN CBA	RTD210	RCN005783-0001
Q308	264346	XISTR NPN CM5783GR SOT23	MAIN CBA	RTD210	RCN005783-0001
Q501	264346	XISTR NPN CM5783GR SOT23	MAIN CBA	RTD210	RCN005783-0001
Q503	264344	XISTR PNP 2SA812 HFE:200~400	MAIN CBA	RTD210	RCP200733-0001
Q701	264344	XISTR PNP 2SA812 HFE:200~400	MAIN CBA	RTD210	RCP200733-0001
Q702	264344	XISTR PNP 2SA812 HFE:200~400	MAIN CBA	RTD210	RCP200733-0001
Q703	264344	XISTR PNP 2SA812 HFE:200~400	MAIN CBA	RTD210	RCP200733-0001
Q704	264344	XISTR PNP 2SA812 HFE:200~400	MAIN CBA	RTD210	RCP200733-0001
R CAB	268243	RIGHT CAB HIPS 94V0	INSTRUMENT	RTD210	BPS211002-0002
R101	264280	CHIP RES. 18K OHM 1/16W 5%	MAIN CBA	RTD210	QCF165030-1830
R102	264291	CHIP RES. 100K OHM 1/16W 5%	MAIN CBA	RTD210	QCF165030-1040
R103	264291	CHIP RES. 100K OHM 1/16W 5%	MAIN CBA	RTD210	QCF165030-1040
R104	264291	CHIP RES. 100K OHM 1/16W 5%	MAIN CBA	RTD210	QCF165030-1040
R105	264279	CHIP RES. 15K OHM 1/16W 5%	MAIN CBA	RTD210	QCF165030-1530
R106	264271	CHIP RES. 1K OHM 1/16W 5%	MAIN CBA	RTD210	QCF165030-1020
R107	264271	CHIP RES. 1K OHM 1/16W 5%	MAIN CBA	RTD210	QCF165030-1020
R108	264271	CHIP RES. 1K OHM 1/16W 5%	MAIN CBA	RTD210	QCF165030-1020
R111	264296	CHIP RES. 1M OHM 1/16W 5%	MAIN CBA	RTD210	QCF165030-1050
R113	266660	SMD RES. 82K OHM 1/16 W 5%	MAIN CBA	RTD210	QCF165030-8230
R114	264273	CHIP RES. 4.7K OHM 1/16W 5 %	MAIN CBA	RTD210	QCF165030-4720
R116	264273	CHIP RES. 4.7K OHM 1/16W 5 %	MAIN CBA	RTD210	QCF165030-4720
R117	264273	CHIP RES. 4.7K OHM 1/16W 5 %	MAIN CBA	RTD210	QCF165030-4720
R118	264273	CHIP RES. 4.7K OHM 1/16W 5 %	MAIN CBA	RTD210	QCF165030-4720
R119	264273	CHIP RES. 4.7K OHM 1/16W 5 %	MAIN CBA	RTD210	QCF165030-4720

Symbol	Stock	Description	Circuit	Model	Drawing
R120	264273	CHIP RES. 4.7K OHM 1/16W 5 %	MAIN CBA	RTD210	QCF165030-4720
R121	264273	CHIP RES. 4.7K OHM 1/16W 5 %	MAIN CBA	RTD210	QCF165030-4720
R122	264273	CHIP RES. 4.7K OHM 1/16W 5 %	MAIN CBA	RTD210	QCF165030-4720
R123	264273	CHIP RES. 4.7K OHM 1/16W 5 %	MAIN CBA	RTD210	QCF165030-4720
R126	264277	CHIP RES. 10K OHM 1/16W 5%	MAIN CBA	RTD210	QCF165030-1030
R127	264277	CHIP RES. 10K OHM 1/16W 5%	MAIN CBA	RTD210	QCF165030-1030
R128	264277	CHIP RES. 10K OHM 1/16W 5%	MAIN CBA	RTD210	QCF165030-1030
R129	264277	CHIP RES. 10K OHM 1/16W 5%	MAIN CBA	RTD210	QCF165030-1030
R130	264277	CHIP RES. 10K OHM 1/16W 5%	MAIN CBA	RTD210	QCF165030-1030
R131	264277	CHIP RES. 10K OHM 1/16W 5%	MAIN CBA	RTD210	QCF165030-1030
R132	264277	CHIP RES. 10K OHM 1/16W 5%	MAIN CBA	RTD210	QCF165030-1030
R133	264278	CHIP RES. 10 OHM 1/16W 5%	MAIN CBA	RTD210	QCF165030-1000
R134	264278	CHIP RES. 10 OHM 1/16W 5%	MAIN CBA	RTD210	QCF165030-1000
R137	264273	CHIP RES. 4.7K OHM 1/16W 5 %	MAIN CBA	RTD210	QCF165030-4720
R138	264273	CHIP RES. 4.7K OHM 1/16W 5 %	MAIN CBA	RTD210	QCF165030-4720
R141	264393	CHIP RES. 12K OHM 1/16W 5%	MAIN CBA	RTD210	QCF165030-1230
R142	266712	SMD RES. 1.5K OHM 1/16 W 5%	MAIN CBA	RTD210	QCF165030-1520
R143	266712	SMD RES. 1.5K OHM 1/16 W 5%	MAIN CBA	RTD210	QCF165030-1520
R144	264281	CHIP RES. 22K OHM 1/16W 5%	MAIN CBA	RTD210	QCF165030-2230
R145	264281	CHIP RES. 22K OHM 1/16W 5%	MAIN CBA	RTD210	QCF165030-2230
R146	264268	CHIP RES. 0 OHM JUMP WIRE	MAIN CBA	RTD210	QCF165030-0000
R148	264268	CHIP RES. 0 OHM JUMP WIRE	MAIN CBA	RTD210	QCF165030-0000
R150	264268	CHIP RES. 0 OHM JUMP WIRE	MAIN CBA	RTD210	QCF165030-0000
R151	264284	CHIP RES. 33 OHM 1/16W 5%	MAIN CBA	RTD210	QCF165030-3300
R152	264284	CHIP RES. 33 OHM 1/16W 5%	MAIN CBA	RTD210	QCF165030-3300
R155	264268	CHIP RES. 0 OHM JUMP WIRE	MAIN CBA	RTD210	QCF165030-0000
R156	264284	CHIP RES. 33 OHM 1/16W 5%	MAIN CBA	RTD210	QCF165030-3300
R157	264284	CHIP RES. 33 OHM 1/16W 5%	MAIN CBA	RTD210	QCF165030-3300
R159	264284	CHIP RES. 33 OHM 1/16W 5%	MAIN CBA	RTD210	QCF165030-3300
R160	264268	CHIP RES. 0 OHM JUMP WIRE	MAIN CBA	RTD210	QCF165030-0000
R161	264284	CHIP RES. 33 OHM 1/16W 5%	MAIN CBA	RTD210	QCF165030-3300
R162	264284	CHIP RES. 33 OHM 1/16W 5%	MAIN CBA	RTD210	QCF165030-3300
R163	264284	CHIP RES. 33 OHM 1/16W 5%	MAIN CBA	RTD210	QCF165030-3300
R164	264268	CHIP RES. 0 OHM JUMP WIRE	MAIN CBA	RTD210	QCF165030-0000
R165	264268	CHIP RES. 0 OHM JUMP WIRE	MAIN CBA	RTD210	QCF165030-0000
R166	264284	CHIP RES. 33 OHM 1/16W 5%	MAIN CBA	RTD210	QCF165030-3300
R167	264284	CHIP RES. 33 OHM 1/16W 5%	MAIN CBA	RTD210	QCF165030-3300
R168	264407	RES CF 33 OHM 1/6W 5%	MAIN CBA	RTD210	QAF065000-3300
R169	264305	CHIP RES. 150 OHM 1/16W 5%	MAIN CBA	RTD210	QCF165030-1510
R171	264269	CHIP RES. 1.2K OHM 1/16W 5%	MAIN CBA	RTD210	QCF165030-1220

Symbol	Stock	Description	Circuit	Model	Drawing
R173	264283	CHIP RES. 33K OHM 1/16W 5%	MAIN CBA	RTD210	QCF165030-3330
R177	264268	CHIP RES. 0 OHM JUMP WIRE	MAIN CBA	RTD210	QCF165030-0000
R178	264272	CHIP RES. 3.3K OHM 1/16W 5%	MAIN CBA	RTD210	QCF165030-3320
R179	264272	CHIP RES. 3.3K OHM 1/16W 5%	MAIN CBA	RTD210	QCF165030-3320
R180	264272	CHIP RES. 3.3K OHM 1/16W 5%	MAIN CBA	RTD210	QCF165030-3320
R181	264272	CHIP RES. 3.3K OHM 1/16W 5%	MAIN CBA	RTD210	QCF165030-3320
R183	266706	SMD RES. 20K OHM 1/16 W 5%	MAIN CBA	RTD210	QCF165030-2030
R185	264268	CHIP RES. 0 OHM JUMP WIRE	MAIN CBA	RTD210	QCF165030-0000
R186	264289	CHIP RES. 75 OHM 1/16W 5%	MAIN CBA	RTD210	QCF165030-7500
R197	264278	CHIP RES. 10 OHM 1/16W 5%	MAIN CBA	RTD210	QCF165030-1000
R200	264296	CHIP RES. 1M OHM 1/16W 5%	MAIN CBA	RTD210	QCF165030-1050
R201	264277	CHIP RES. 10K OHM 1/16W 5%	MAIN CBA	RTD210	QCF165030-1030
R301	264273	CHIP RES. 4.7K OHM 1/16W 5 %	MAIN CBA	RTD210	QCF165030-4720
R302	264273	CHIP RES. 4.7K OHM 1/16W 5 %	MAIN CBA	RTD210	QCF165030-4720
R303	264273	CHIP RES. 4.7K OHM 1/16W 5 %	MAIN CBA	RTD210	QCF165030-4720
R304	264273	CHIP RES. 4.7K OHM 1/16W 5 %	MAIN CBA	RTD210	QCF165030-4720
R305	264273	CHIP RES. 4.7K OHM 1/16W 5 %	MAIN CBA	RTD210	QCF165030-4720
R306	264273	CHIP RES. 4.7K OHM 1/16W 5 %	MAIN CBA	RTD210	QCF165030-4720
R307	264273	CHIP RES. 4.7K OHM 1/16W 5 %	MAIN CBA	RTD210	QCF165030-4720
R308	264273	CHIP RES. 4.7K OHM 1/16W 5 %	MAIN CBA	RTD210	QCF165030-4720
R309	264273	CHIP RES. 4.7K OHM 1/16W 5 %	MAIN CBA	RTD210	QCF165030-4720
R310	264273	CHIP RES. 4.7K OHM 1/16W 5 %	MAIN CBA	RTD210	QCF165030-4720
R311	264273	CHIP RES. 4.7K OHM 1/16W 5 %	MAIN CBA	RTD210	QCF165030-4720
R312	264273	CHIP RES. 4.7K OHM 1/16W 5 %	MAIN CBA	RTD210	QCF165030-4720
R313	264273	CHIP RES. 4.7K OHM 1/16W 5 %	MAIN CBA	RTD210	QCF165030-4720
R314	264273	CHIP RES. 4.7K OHM 1/16W 5 %	MAIN CBA	RTD210	QCF165030-4720
R315	264273	CHIP RES. 4.7K OHM 1/16W 5 %	MAIN CBA	RTD210	QCF165030-4720
R316	264273	CHIP RES. 4.7K OHM 1/16W 5 %	MAIN CBA	RTD210	QCF165030-4720
R317	264273	CHIP RES. 4.7K OHM 1/16W 5 %	MAIN CBA	RTD210	QCF165030-4720
R318	264273	CHIP RES. 4.7K OHM 1/16W 5 %	MAIN CBA	RTD210	QCF165030-4720
R319	264273	CHIP RES. 4.7K OHM 1/16W 5 %	MAIN CBA	RTD210	QCF165030-4720
R320	264273	CHIP RES. 4.7K OHM 1/16W 5 %	MAIN CBA	RTD210	QCF165030-4720
R321	264273	CHIP RES. 4.7K OHM 1/16W 5 %	MAIN CBA	RTD210	QCF165030-4720
R322	264273	CHIP RES. 4.7K OHM 1/16W 5 %	MAIN CBA	RTD210	QCF165030-4720
R323	264273	CHIP RES. 4.7K OHM 1/16W 5 %	MAIN CBA	RTD210	QCF165030-4720
R324	264273	CHIP RES. 4.7K OHM 1/16W 5 %	MAIN CBA	RTD210	QCF165030-4720
R336	268200	CHIP RES. 5.1 OHM 1/16 W 5%	MAIN CBA	RTD210	QCF165030-5190
R337	264280	CHIP RES. 18K OHM 1/16W 5%	MAIN CBA	RTD210	QCF165030-1830
R338	264280	CHIP RES. 18K OHM 1/16W 5%	MAIN CBA	RTD210	QCF165030-1830
R339	264280	CHIP RES. 18K OHM 1/16W 5%	MAIN CBA	RTD210	QCF165030-1830

Symbol	Stock	Description	Circuit	Model	Drawing
R340	264280	CHIP RES. 18K OHM 1/16W 5%	MAIN CBA	RTD210	QCF165030-1830
R341	264280	CHIP RES. 18K OHM 1/16W 5%	MAIN CBA	RTD210	QCF165030-1830
R342	264280	CHIP RES. 18K OHM 1/16W 5%	MAIN CBA	RTD210	QCF165030-1830
R343	264280	CHIP RES. 18K OHM 1/16W 5%	MAIN CBA	RTD210	QCF165030-1830
R344	264280	CHIP RES. 18K OHM 1/16W 5%	MAIN CBA	RTD210	QCF165030-1830
R355	264277	CHIP RES. 10K OHM 1/16W 5%	MAIN CBA	RTD210	QCF165030-1030
R356	264277	CHIP RES. 10K OHM 1/16W 5%	MAIN CBA	RTD210	QCF165030-1030
R357	264277	CHIP RES. 10K OHM 1/16W 5%	MAIN CBA	RTD210	QCF165030-1030
R358	264268	CHIP RES. 0 OHM JUMP WIRE	MAIN CBA	RTD210	QCF165030-0000
R360	264271	CHIP RES. 1K OHM 1/16W 5%	MAIN CBA	RTD210	QCF165030-1020
R361	264271	CHIP RES. 1K OHM 1/16W 5%	MAIN CBA	RTD210	QCF165030-1020
R362	264271	CHIP RES. 1K OHM 1/16W 5%	MAIN CBA	RTD210	QCF165030-1020
R363	264271	CHIP RES. 1K OHM 1/16W 5%	MAIN CBA	RTD210	QCF165030-1020
R364	264291	CHIP RES. 100K OHM 1/16W 5%	MAIN CBA	RTD210	QCF165030-1040
R365	264291	CHIP RES. 100K OHM 1/16W 5%	MAIN CBA	RTD210	QCF165030-1040
R367	264291	CHIP RES. 100K OHM 1/16W 5%	MAIN CBA	RTD210	QCF165030-1040
R368	264271	CHIP RES. 1K OHM 1/16W 5%	MAIN CBA	RTD210	QCF165030-1020
R369	264271	CHIP RES. 1K OHM 1/16W 5%	MAIN CBA	RTD210	QCF165030-1020
R372	264291	CHIP RES. 100K OHM 1/16W 5%	MAIN CBA	RTD210	QCF165030-1040
R375	264272	CHIP RES. 3.3K OHM 1/16W 5%	MAIN CBA	RTD210	QCF165030-3320
R376	264272	CHIP RES. 3.3K OHM 1/16W 5%	MAIN CBA	RTD210	QCF165030-3320
R377	264271	CHIP RES. 1K OHM 1/16W 5%	MAIN CBA	RTD210	QCF165030-1020
R378	264291	CHIP RES. 100K OHM 1/16W 5%	MAIN CBA	RTD210	QCF165030-1040
R379	264291	CHIP RES. 100K OHM 1/16W 5%	MAIN CBA	RTD210	QCF165030-1040
R380	264291	CHIP RES. 100K OHM 1/16W 5%	MAIN CBA	RTD210	QCF165030-1040
R381	264286	CHIP RES. 47K OHM 1/16W 5 %	MAIN CBA	RTD210	QCF165030-4730
R382	264286	CHIP RES. 47K OHM 1/16W 5 %	MAIN CBA	RTD210	QCF165030-4730
R385	264291	CHIP RES. 100K OHM 1/16W 5%	MAIN CBA	RTD210	QCF165030-1040
R386	264291	CHIP RES. 100K OHM 1/16W 5%	MAIN CBA	RTD210	QCF165030-1040
R392	264273	CHIP RES. 4.7K OHM 1/16W 5 %	MAIN CBA	RTD210	QCF165030-4720
R396	264409	RES CF 10K OHM 1/6W 5%	MAIN CBA	RTD210	QAF065000-1030
R399	264286	CHIP RES. 47K OHM 1/16W 5 %	MAIN CBA	RTD210	QCF165030-4730
R400	264286	CHIP RES. 47K OHM 1/16W 5 %	MAIN CBA	RTD210	QCF165030-4730
R401	264286	CHIP RES. 47K OHM 1/16W 5 %	MAIN CBA	RTD210	QCF165030-4730
R402	264286	CHIP RES. 47K OHM 1/16W 5 %	MAIN CBA	RTD210	QCF165030-4730
R403	264286	CHIP RES. 47K OHM 1/16W 5 %	MAIN CBA	RTD210	QCF165030-4730
R405	264297	CHIP RES. 2.2 OHM 1/16W 5%	MAIN CBA	RTD210	QCF165030-2290
R406	264297	CHIP RES. 2.2 OHM 1/16W 5%	MAIN CBA	RTD210	QCF165030-2290
R407	266711	SMD RES. 4.7 OHM 1/16 W 5%	MAIN CBA	RTD210	QCF165030-4790
R408	266711	SMD RES. 4.7 OHM 1/16 W 5%	MAIN CBA	RTD210	QCF165030-4790

Symbol	Stock	Description	Circuit	Model	Drawing
R409	264403	RES CF 4.7K OHM 1/6W 5%	MAIN CBA	RTD210	QAF065000-4720
R410	264273	CHIP RES. 4.7K OHM 1/16W 5 %	MAIN CBA	RTD210	QCF165030-4720
R411	264273	CHIP RES. 4.7K OHM 1/16W 5 %	MAIN CBA	RTD210	QCF165030-4720
R412	264273	CHIP RES. 4.7K OHM 1/16W 5 %	MAIN CBA	RTD210	QCF165030-4720
R413	264273	CHIP RES. 4.7K OHM 1/16W 5 %	MAIN CBA	RTD210	QCF165030-4720
R414	264273	CHIP RES. 4.7K OHM 1/16W 5 %	MAIN CBA	RTD210	QCF165030-4720
R415	264273	CHIP RES. 4.7K OHM 1/16W 5 %	MAIN CBA	RTD210	QCF165030-4720
R418	264410	RES CF 470 OHM 1/6W 5%	MAIN CBA	RTD210	QAF065000-4710
R419	264410	RES CF 470 OHM 1/6W 5%	MAIN CBA	RTD210	QAF065000-4710
R420	264284	CHIP RES. 33 OHM 1/16W 5%	MAIN CBA	RTD210	QCF165030-3300
R421	268220	CHIP RES. 100 OHM 1/8 W 5%	MAIN CBA	RTD210	QCF085020-1010
R423	268210	CHIP RES. 150 OHM 1/10 W 5%	MAIN CBA	RTD210	QCF015020-1510
R429	264284	CHIP RES. 33 OHM 1/16W 5%	MAIN CBA	RTD210	QCF165030-3300
R430	264284	CHIP RES. 33 OHM 1/16W 5%	MAIN CBA	RTD210	QCF165030-3300
R431	264284	CHIP RES. 33 OHM 1/16W 5%	MAIN CBA	RTD210	QCF165030-3300
R432	264284	CHIP RES. 33 OHM 1/16W 5%	MAIN CBA	RTD210	QCF165030-3300
R433	264284	CHIP RES. 33 OHM 1/16W 5%	MAIN CBA	RTD210	QCF165030-3300
R434	264284	CHIP RES. 33 OHM 1/16W 5%	MAIN CBA	RTD210	QCF165030-3300
R435	264284	CHIP RES. 33 OHM 1/16W 5%	MAIN CBA	RTD210	QCF165030-3300
R436	264284	CHIP RES. 33 OHM 1/16W 5%	MAIN CBA	RTD210	QCF165030-3300
R437	264407	RES CF 33 OHM 1/6W 5%	MAIN CBA	RTD210	QAF065000-3300
R438	264407	RES CF 33 OHM 1/6W 5%	MAIN CBA	RTD210	QAF065000-3300
R439	264284	CHIP RES. 33 OHM 1/16W 5%	MAIN CBA	RTD210	QCF165030-3300
R440	264407	RES CF 33 OHM 1/6W 5%	MAIN CBA	RTD210	QAF065000-3300
R441	264284	CHIP RES. 33 OHM 1/16W 5%	MAIN CBA	RTD210	QCF165030-3300
R442	264284	CHIP RES. 33 OHM 1/16W 5%	MAIN CBA	RTD210	QCF165030-3300
R443	264284	CHIP RES. 33 OHM 1/16W 5%	MAIN CBA	RTD210	QCF165030-3300
R444	264284	CHIP RES. 33 OHM 1/16W 5%	MAIN CBA	RTD210	QCF165030-3300
R501	264286	CHIP RES. 47K OHM 1/16W 5 %	MAIN CBA	RTD210	QCF165030-4730
R502	264268	CHIP RES. 0 OHM JUMP WIRE	MAIN CBA	RTD210	QCF165030-0000
R503	264268	CHIP RES. 0 OHM JUMP WIRE	MAIN CBA	RTD210	QCF165030-0000
R504	264281	CHIP RES. 22K OHM 1/16W 5%	MAIN CBA	RTD210	QCF165030-2230
R505	264281	CHIP RES. 22K OHM 1/16W 5%	MAIN CBA	RTD210	QCF165030-2230
R506	264277	CHIP RES. 10K OHM 1/16W 5%	MAIN CBA	RTD210	QCF165030-1030
R507	264313	CHIP RES. 20 OHM 1/4W 5%	MAIN CBA	RTD210	QCF045010-2000
R508	264313	CHIP RES. 20 OHM 1/4W 5%	MAIN CBA	RTD210	QCF045010-2000
R509	268209	CHIP RES. 15 OHM 1/4 W 5%	MAIN CBA	RTD210	QCF045010-1500
R51	264313	CHIP RES. 20 OHM 1/4W 5%	MAIN CBA	RTD210	QCF045010-2000
R510	264313	CHIP RES. 20 OHM 1/4W 5%	MAIN CBA	RTD210	QCF045010-2000
R511	264277	CHIP RES. 10K OHM 1/16W 5%	MAIN CBA	RTD210	QCF165030-1030

Symbol	Stock	Description	Circuit	Model	Drawing
R512	264277	CHIP RES. 10K OHM 1/16W 5%	MAIN CBA	RTD210	QCF165030-1030
R514	268209	CHIP RES. 15 OHM 1/4 W 5%	MAIN CBA	RTD210	QCF045010-1500
R516	264281	CHIP RES. 22K OHM 1/16W 5%	MAIN CBA	RTD210	QCF165030-2230
R517	264271	CHIP RES. 1K OHM 1/16W 5%	MAIN CBA	RTD210	QCF165030-1020
R518	264409	RES CF 10K OHM 1/6W 5%	MAIN CBA	RTD210	QAF065000-1030
R519	268219	CHIP RES. 3 OHM 1/4 W 5%	MAIN CBA	RTD210	QCF045010-3090
R520	268219	CHIP RES. 3 OHM 1/4 W 5%	MAIN CBA	RTD210	QCF045010-3090
R521	268219	CHIP RES. 3 OHM 1/4 W 5%	MAIN CBA	RTD210	QCF045010-3090
R522	268219	CHIP RES. 3 OHM 1/4 W 5%	MAIN CBA	RTD210	QCF045010-3090
R523	264314	CHIP RES. 4.7 OHM 1/4W 5%	MAIN CBA	RTD210	QCF045010-4790
R524	264314	CHIP RES. 4.7 OHM 1/4W 5%	MAIN CBA	RTD210	QCF045010-4790
R525	266680	RESISTOR 100 OHM 1/2 W 5%	MAIN CBA	RTD210	QAF025000-1010
R526	266681	RES 150 OHM 1/2 W 5% CF	MAIN CBA	RTD210	QAF025000-1510
R528	264268	CHIP RES. 0 OHM JUMP WIRE	MAIN CBA	RTD210	QCF165030-0000
R529	264268	CHIP RES. 0 OHM JUMP WIRE	MAIN CBA	RTD210	QCF165030-0000
R530	264314	CHIP RES. 4.7 OHM 1/4W 5%	MAIN CBA	RTD210	QCF045010-4790
R531	264314	CHIP RES. 4.7 OHM 1/4W 5%	MAIN CBA	RTD210	QCF045010-4790
R548	264268	CHIP RES. 0 OHM JUMP WIRE	MAIN CBA	RTD210	QCF165030-0000
R549	264268	CHIP RES. 0 OHM JUMP WIRE	MAIN CBA	RTD210	QCF165030-0000
R550	264268	CHIP RES. 0 OHM JUMP WIRE	MAIN CBA	RTD210	QCF165030-0000
R551	264268	CHIP RES. 0 OHM JUMP WIRE	MAIN CBA	RTD210	QCF165030-0000
R701	264277	CHIP RES. 10K OHM 1/16W 5%	MAIN CBA	RTD210	QCF165030-1030
R702	264277	CHIP RES. 10K OHM 1/16W 5%	MAIN CBA	RTD210	QCF165030-1030
R703	264277	CHIP RES. 10K OHM 1/16W 5%	MAIN CBA	RTD210	QCF165030-1030
R704	264277	CHIP RES. 10K OHM 1/16W 5%	MAIN CBA	RTD210	QCF165030-1030
R705	264277	CHIP RES. 10K OHM 1/16W 5%	MAIN CBA	RTD210	QCF165030-1030
R706	264277	CHIP RES. 10K OHM 1/16W 5%	MAIN CBA	RTD210	QCF165030-1030
R707	264277	CHIP RES. 10K OHM 1/16W 5%	MAIN CBA	RTD210	QCF165030-1030
R708	264277	CHIP RES. 10K OHM 1/16W 5%	MAIN CBA	RTD210	QCF165030-1030
R709	264277	CHIP RES. 10K OHM 1/16W 5%	MAIN CBA	RTD210	QCF165030-1030
R710	264277	CHIP RES. 10K OHM 1/16W 5%	MAIN CBA	RTD210	QCF165030-1030
R711	264277	CHIP RES. 10K OHM 1/16W 5%	MAIN CBA	RTD210	QCF165030-1030
R712	264277	CHIP RES. 10K OHM 1/16W 5%	MAIN CBA	RTD210	QCF165030-1030
R713	264277	CHIP RES. 10K OHM 1/16W 5%	MAIN CBA	RTD210	QCF165030-1030
R714	264277	CHIP RES. 10K OHM 1/16W 5%	MAIN CBA	RTD210	QCF165030-1030
R715	264277	CHIP RES. 10K OHM 1/16W 5%	MAIN CBA	RTD210	QCF165030-1030
R716	264277	CHIP RES. 10K OHM 1/16W 5%	MAIN CBA	RTD210	QCF165030-1030
R717	264277	CHIP RES. 10K OHM 1/16W 5%	MAIN CBA	RTD210	QCF165030-1030
R718	264271	CHIP RES. 1K OHM 1/16W 5%	MAIN CBA	RTD210	QCF165030-1020
R719	264271	CHIP RES. 1K OHM 1/16W 5%	MAIN CBA	RTD210	QCF165030-1020



Symbol	Stock	Description	Circuit	Model	Drawing
R720	264271	CHIP RES. 1K OHM 1/16W 5%	MAIN CBA	RTD210	QCF165030-1020
R721	264398	CHIP RES. 560 OHM 1/16W 5 %	MAIN CBA	RTD210	QCF165030-5610
R722	264398	CHIP RES. 560 OHM 1/16W 5 %	MAIN CBA	RTD210	QCF165030-5610
R723	264277	CHIP RES. 10K OHM 1/16W 5%	MAIN CBA	RTD210	QCF165030-1030
R724	264291	CHIP RES. 100K OHM 1/16W 5%	MAIN CBA	RTD210	QCF165030-1040
R725	264281	CHIP RES. 22K OHM 1/16W 5%	MAIN CBA	RTD210	QCF165030-2230
R726	264273	CHIP RES. 4.7K OHM 1/16W 5 %	MAIN CBA	RTD210	QCF165030-4720
R727	264290	CHIP RES. 100 OHM 1/16W 5%	MAIN CBA	RTD210	QCF165030-1010
R728	264290	CHIP RES. 100 OHM 1/16W 5%	MAIN CBA	RTD210	QCF165030-1010
R729	264290	CHIP RES. 100 OHM 1/16W 5%	MAIN CBA	RTD210	QCF165030-1010
R730	264290	CHIP RES. 100 OHM 1/16W 5%	MAIN CBA	RTD210	QCF165030-1010
R731	264291	CHIP RES. 100K OHM 1/16W 5%	MAIN CBA	RTD210	QCF165030-1040
R732	264273	CHIP RES. 4.7K OHM 1/16W 5 %	MAIN CBA	RTD210	QCF165030-4720
R733	264271	CHIP RES. 1K OHM 1/16W 5%	MAIN CBA	RTD210	QCF165030-1020
R734	268221	CHIP RES. 0 OHM JUMP WIRE	MAIN CBA	RTD210	QCF015020-0000
R738	264277	CHIP RES. 10K OHM 1/16W 5%	MAIN CBA	RTD210	QCF165030-1030
R739	264271	CHIP RES. 1K OHM 1/16W 5%	MAIN CBA	RTD210	QCF165030-1020
RB701	266639	WIRE 8PIN 260MM	MAIN CBA	RTD210	VFL801245-2600
RB702	266640	D/WIRE 6PIN 120MM	MAIN CBA	RTD210	VFL601245-1200
RB703	268225	CON/WIRE 4P 200MM 246826 RAINB	MAIN CBA	RTD210	VFL401255-2000
RB704	268225	CON/WIRE 4P 200MM 246826 RAINB	MAIN CBA	RTD210	VFL401255-2000
RB705	268214	CON/CABLE 3P 400MM 285430X2C G	MAIN CBA	RTD210	VSW3G5452-4000
RB801	264265	CONNECTOR 4 PIN PITCH=2.0MM	MAIN CBA	RTD210	CCN200000-0104
RCOVERR	268241	RECEIVER R-COVER ABS 235X218X3	INSTRUMENT	RTD210	BPV300015-0001
RECASSY	268233	COMPLETE UNIT RECEIVER ASSY (U	INSTRUMENT	RTD210	AFLTL8010-0001
REMOTE	266719	REMOTE CONTROL 41 KEYS	INSTRUMENT	RTD210	WIR241001-CL07
SD LENS	268244	SIDE LENS ARCYLIC	INSTRUMENT	RTD210	BPN200044-0002
SN701	264450	SENSOR 2.4V 56.7KHZ MIM	MAIN CBA	RTD210	RHO001356-2002
SPEAKER	268247	SAT.75WX2+100WX1+50WX2	INSTRUMENT	RTD210	ESB20C501-0602
ST LENS	268245	STANDBY LENS MILKY ABS	INSTRUMENT	RTD210	BPN200045-0001
ST SW	268212	TACT SWITCH	MAIN CBA	RTD210	MRW106002-1020
SUBW	268246	SUB100W PASSIVE WOOFER TX DR36	INSTRUMENT	RTD210	ESW20A001-0602
SW1	268250	TRANSMITTER DIP SWITCH 3 POS 6	INSTRUMENT	RTD210	MSW001007-0020
SW2	268250	TRANSMITTER DIP SWITCH 3 POS 6	INSTRUMENT	RTD210	MSW001007-0020
SWITCH	268242	RECEIVER SW ROCKER SOLTEAM OR	INSTRUMENT	RTD210	MSW008003-0010
T COVER	268271	TRANSMITTER TOP COVER	INSTRUMENT	RTD210	BPQ500143-0001
TA701	266641	TACT SWITCH L5.85MM TS6601VB	MAIN CBA	RTD210	MVW006002-0010
TA702	266641	TACT SWITCH L5.85MM TS6601VB	MAIN CBA	RTD210	MVW006002-0010
TA703	266641	TACT SWITCH L5.85MM TS6601VB	MAIN CBA	RTD210	MVW006002-0010
TA704	266641	TACT SWITCH L5.85MM TS6601VB	MAIN CBA	RTD210	MVW006002-0010

Symbol	Stock	Description	Circuit	Model	Drawing
TA705	266641	TACT SWITCH L5.85MM TS6601VB	MAIN CBA	RTD210	MVW006002-0010
TA706	266641	TACT SWITCH L5.85MM TS6601VB	MAIN CBA	RTD210	MVW006002-0010
TA707	266641	TACT SWITCH L5.85MM TS6601VB	MAIN CBA	RTD210	MVW006002-0010
TA708	268211	TACT SW H=5MM 160GF PLASTIC	MAIN CBA	RTD210	MAW106001-0011
TOP CAB	268248	TOP CAB (BPC200005-0001 MODIFY	INSTRUMENT	RTD210	BPC200005-0101
TRANSM	268234	COMPLETE UNIT TRANSMITTER ASSY	INSTRUMENT	RTD210	AFLTL8010-0002
TRAY	268263	RECEIVER ANTENNA TRAY BAKELITE	INSTRUMENT	RTD210	ICH309001-0001
TU101	268273	TUNER PACK KST-ML011MAO-30 KWA	INSTRUMENT	RTD210	WTP000011-0010
V KNOB	266688	VOLUME KNOB	INSTRUMENT	RTD210	BPK208037-0001
VR701	266642	ROTARY ENCODER EC121102F2B-HA1	MAIN CBA	RTD210	MSW005012-0110
X101	266667	CRYSTAL 27 MHZ HC-49US	MAIN CBA	RTD210	JQC021000-2760
XL701	264449	CRYSTAL 4.5000MHZ	MAIN CBA	RTD210	JQC023102-4550
XL701	268224	CRYSTAL 4.5000MHZ HC-49/S +/-2	MAIN CBA	RTD210	JQC052103-4550
ZD102	264340	CHIP ZENER 7.5V 5% 0.5W	MAIN CBA	RTD210	RCZ005007-0021
ZD103	264340	CHIP ZENER 7.5V 5% 0.5W	MAIN CBA	RTD210	RCZ005007-0021
ZD104	264340	CHIP ZENER 7.5V 5% 0.5W	MAIN CBA	RTD210	RCZ005007-0021
ZD105	264340	CHIP ZENER 7.5V 5% 0.5W	MAIN CBA	RTD210	RCZ005007-0021
ZD106	264340	CHIP ZENER 7.5V 5% 0.5W	MAIN CBA	RTD210	RCZ005007-0021
ZD107	264340	CHIP ZENER 7.5V 5% 0.5W	MAIN CBA	RTD210	RCZ005007-0021
ZD108	264340	CHIP ZENER 7.5V 5% 0.5W	MAIN CBA	RTD210	RCZ005007-0021
ZD109	264340	CHIP ZENER 7.5V 5% 0.5W	MAIN CBA	RTD210	RCZ005007-0021
ZD110	264340	CHIP ZENER 7.5V 5% 0.5W	MAIN CBA	RTD210	RCZ005007-0021
ZD111	264340	CHIP ZENER 7.5V 5% 0.5W	MAIN CBA	RTD210	RCZ005007-0021
ZD301	264341	CHIP ZENER 5.6V 5% 0.5W	MAIN CBA	RTD210	RCZ005006-0011
ZD302	264341	CHIP ZENER 5.6V 5% 0.5W	MAIN CBA	RTD210	RCZ005006-0011
ZD303	264341	CHIP ZENER 5.6V 5% 0.5W	MAIN CBA	RTD210	RCZ005006-0011
ZD701	264341	CHIP ZENER 5.6V 5% 0.5W	MAIN CBA	RTD210	RCZ005006-0011

# RTD210 CONTROL BOARD SCHEMATIC

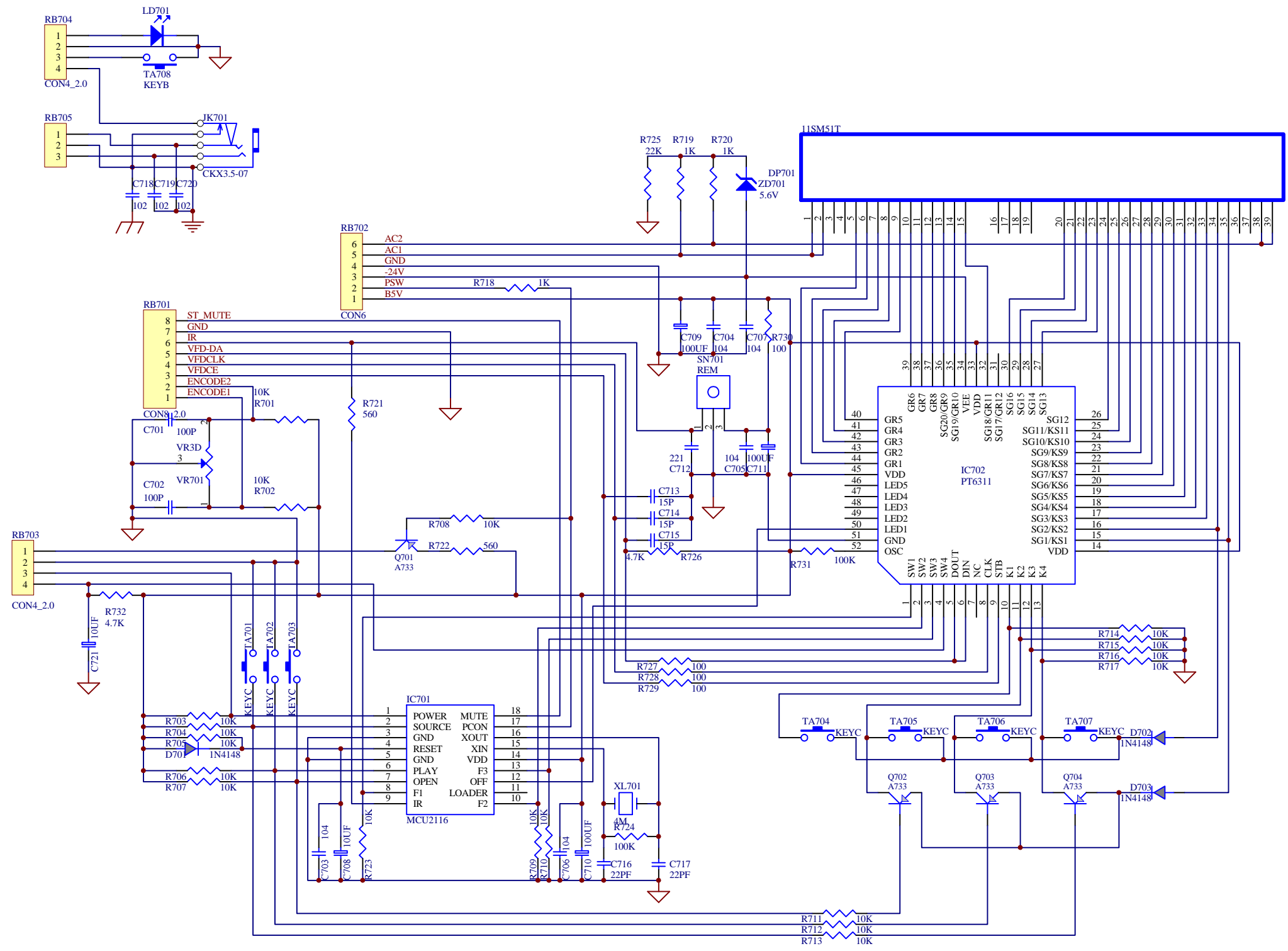

# RTD210 AUDIO PROCESSING SCHEMATIC

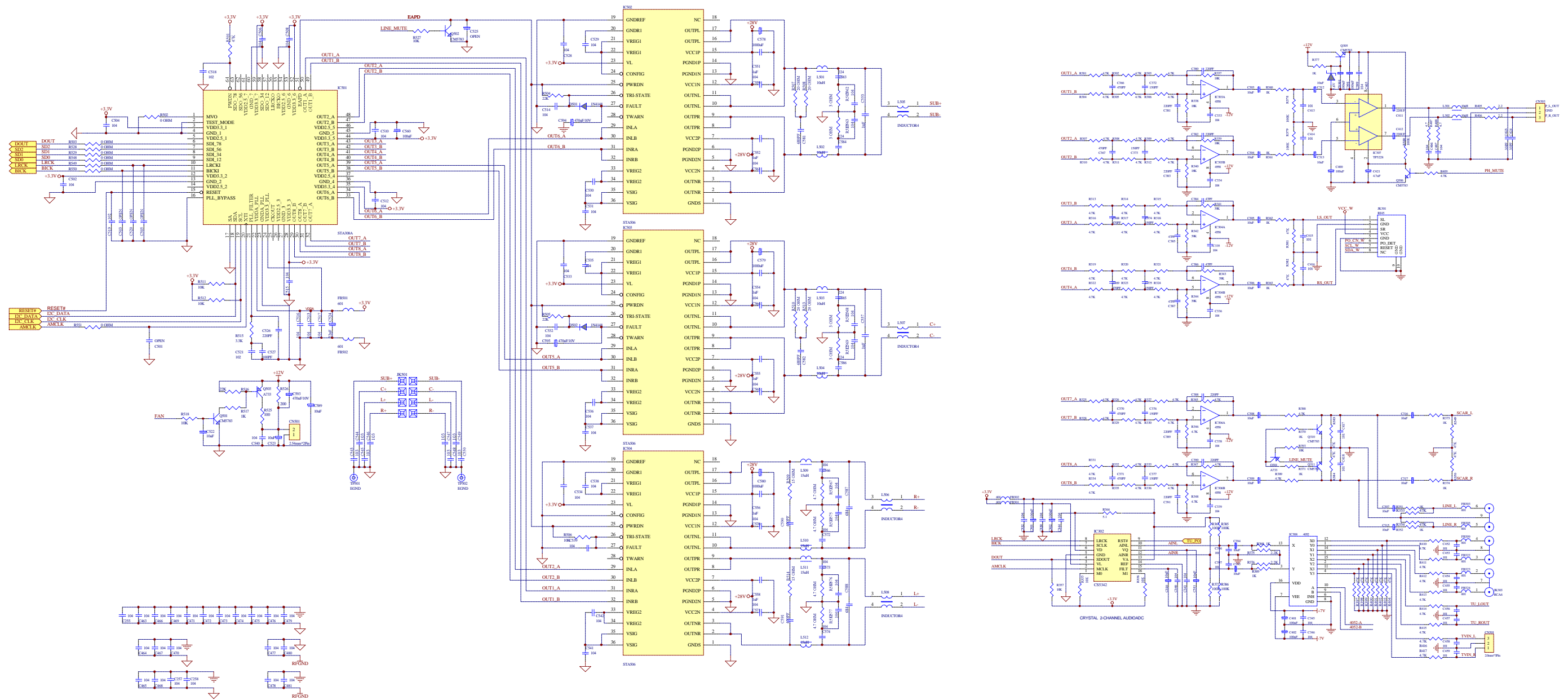

# RTD210 MAIN DVD SCHEMATIC

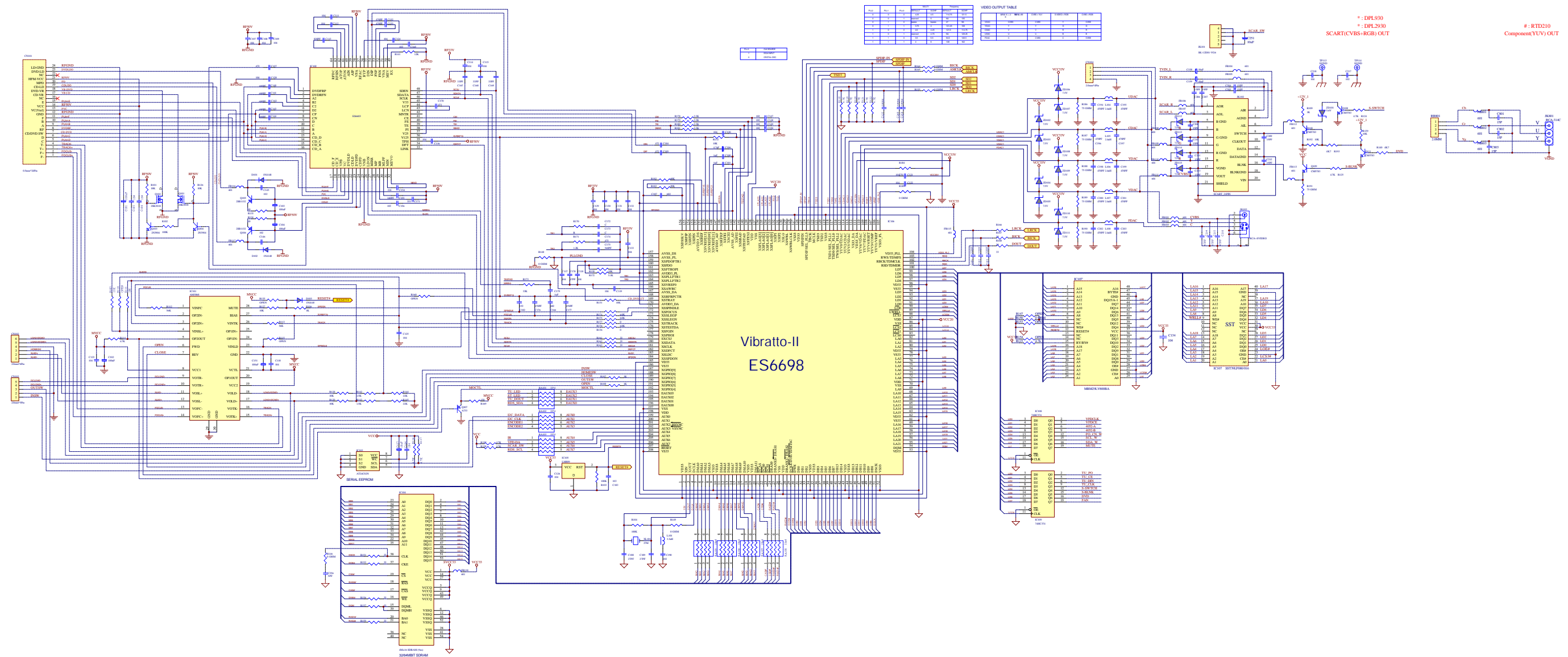

# RTD210 MAIN SUB POWER/COAX SCHEMATIC

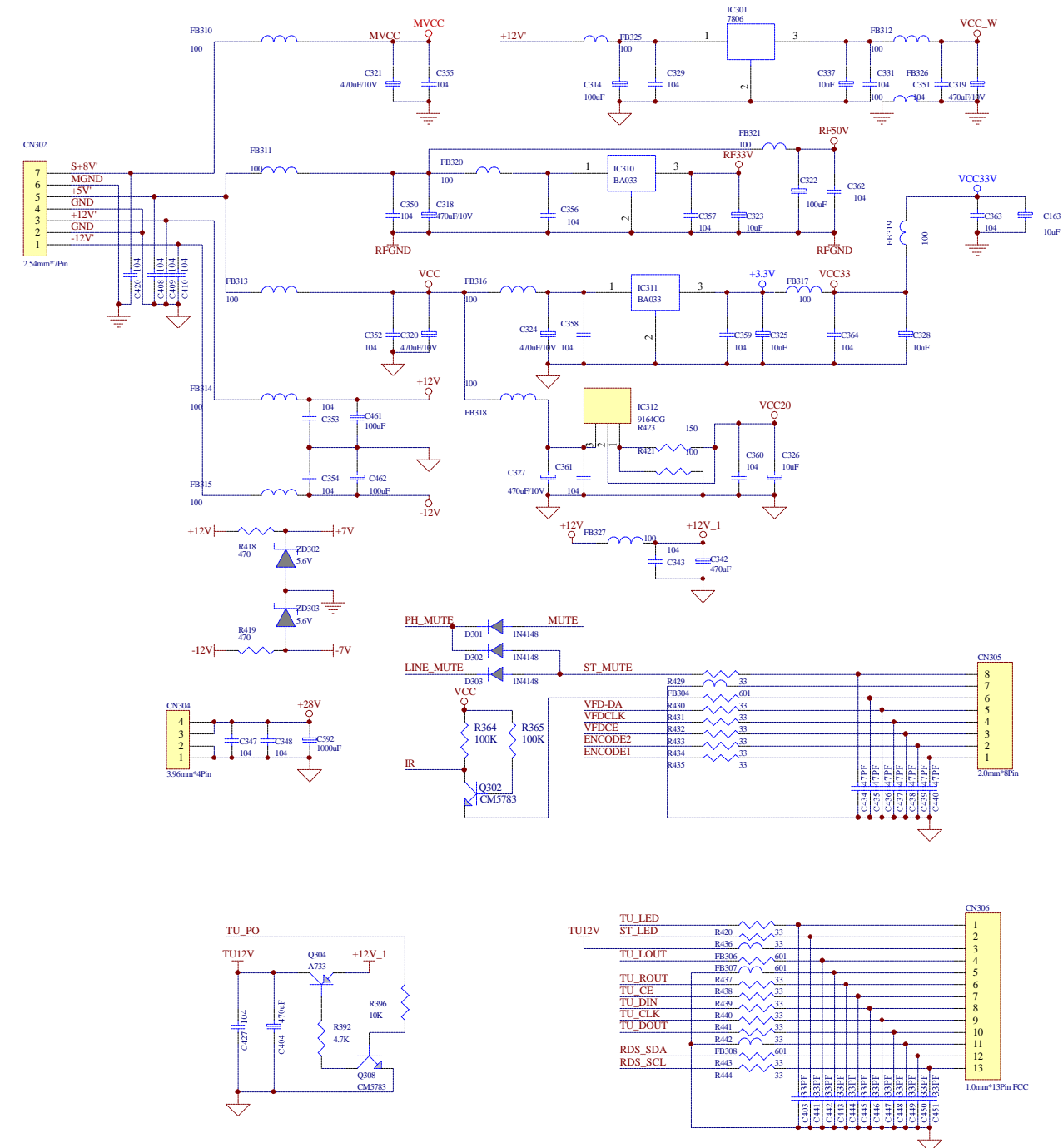
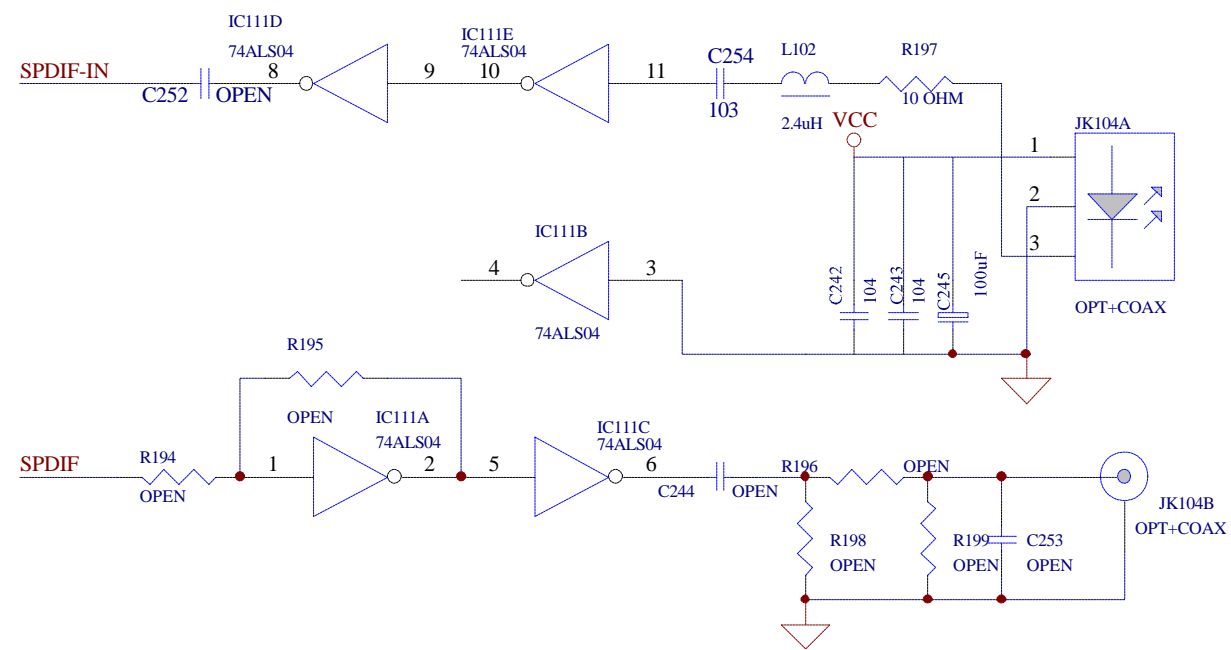
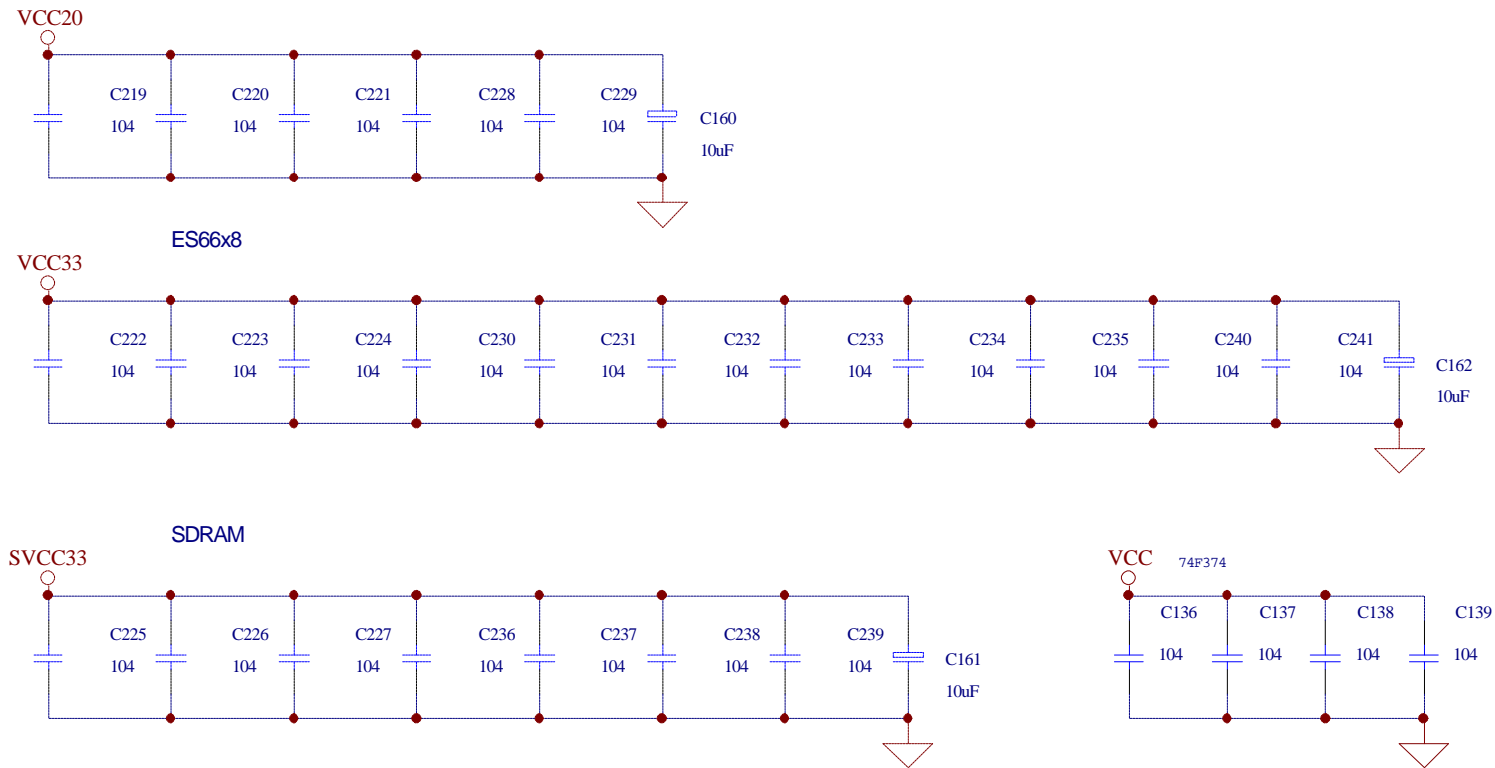

# RTD120 RECEIVER AUDIO SCHEMATIC

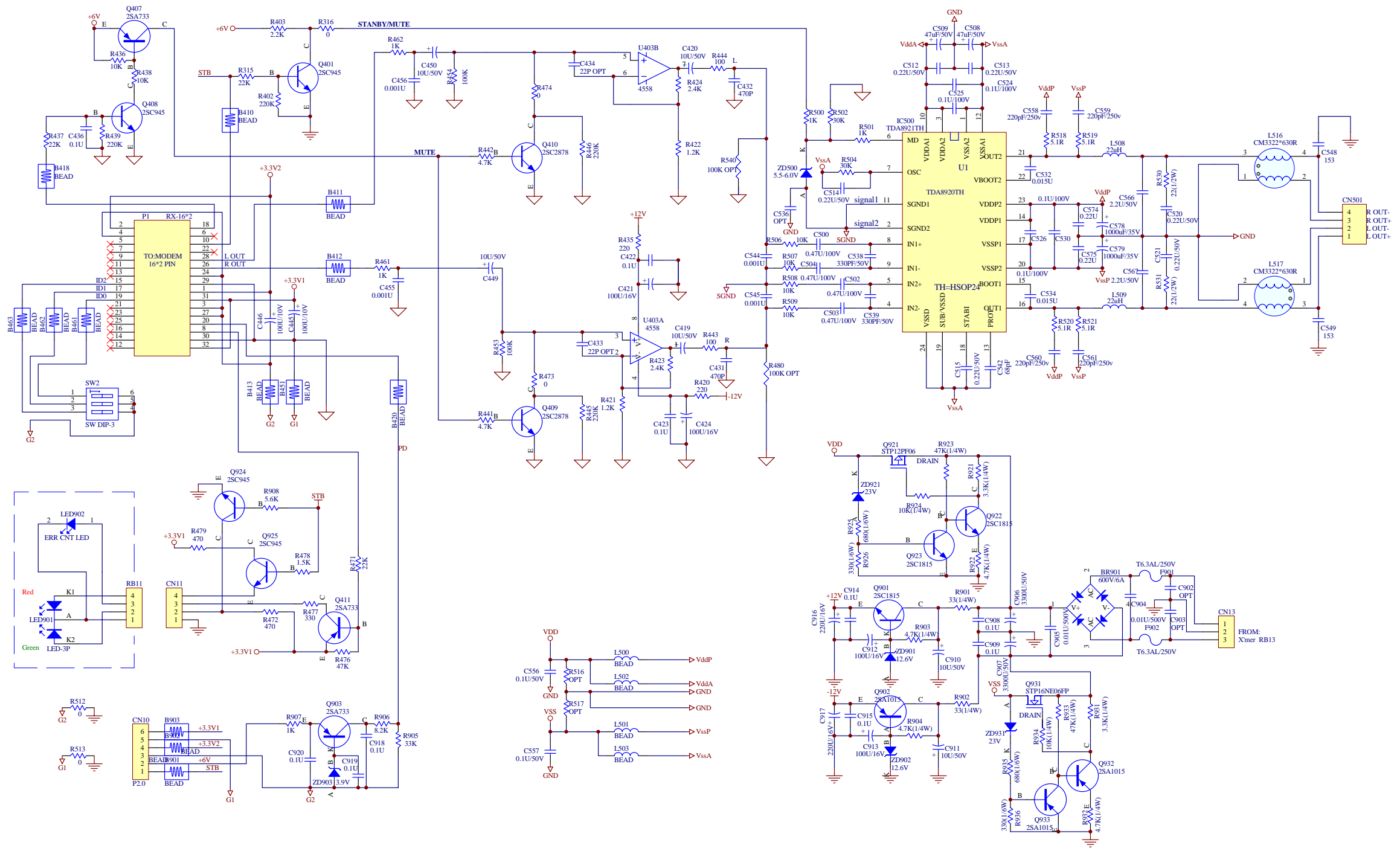

# RTD210 RECEIVER SCHEMATIC (PG 1)

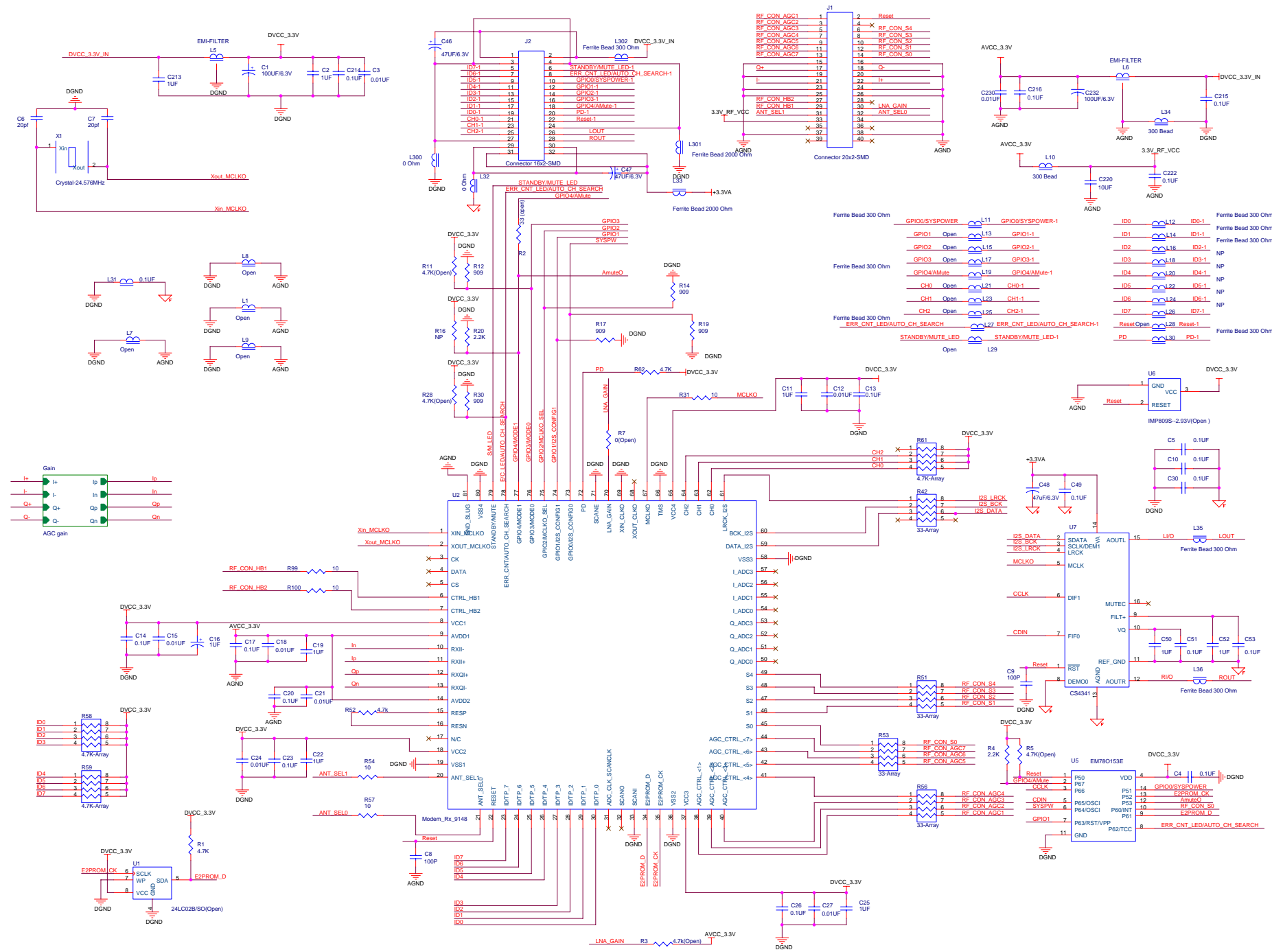



# RTD210 RECEIVER SCHEMATIC (PG 2)

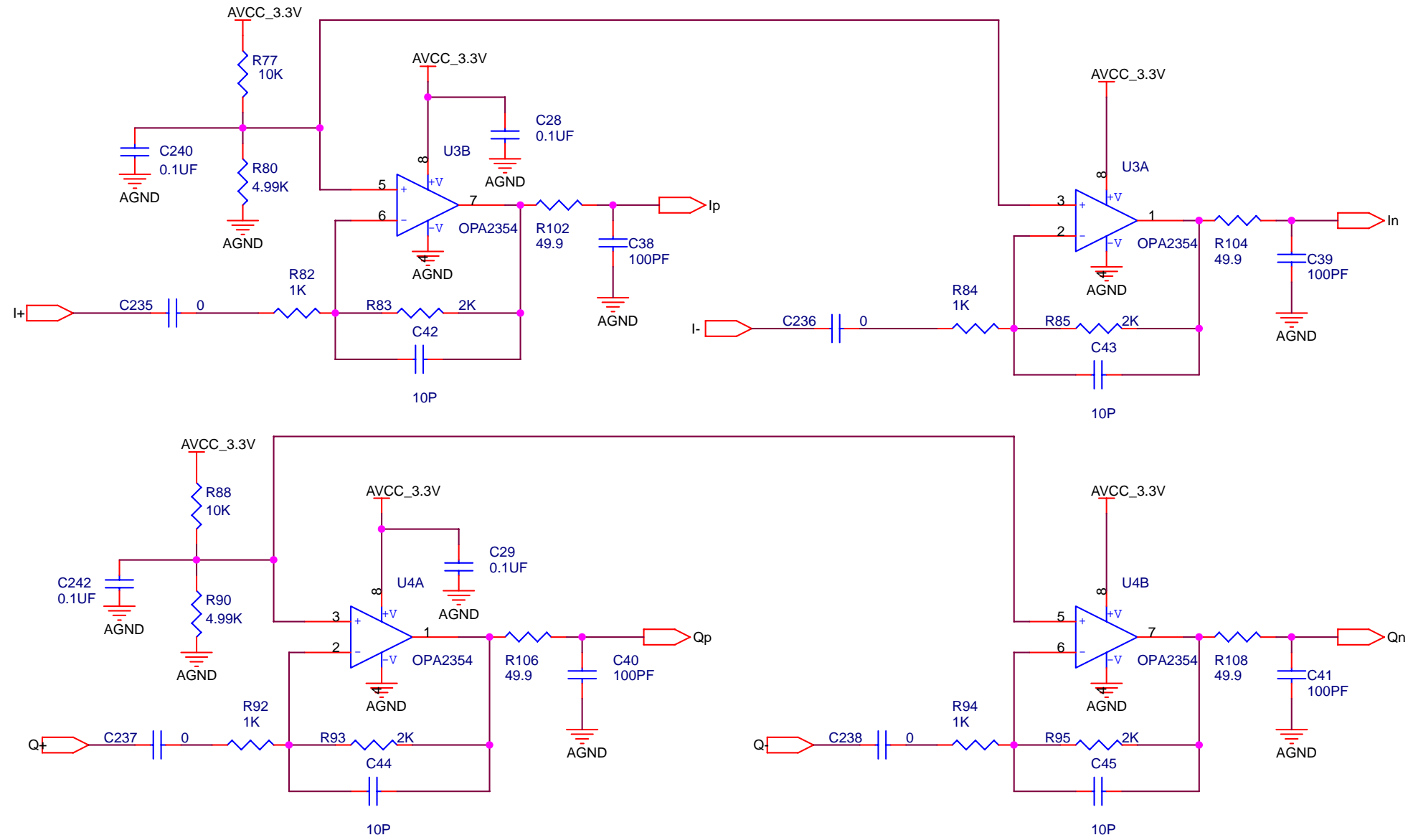

# RTD120 RECEIVER RF SCHEMATIC

## Voltage Regulators

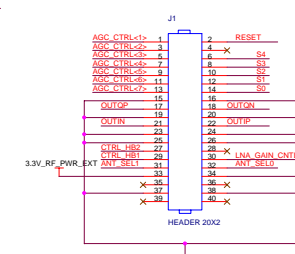
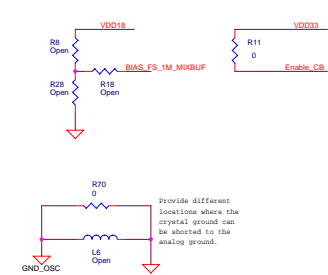
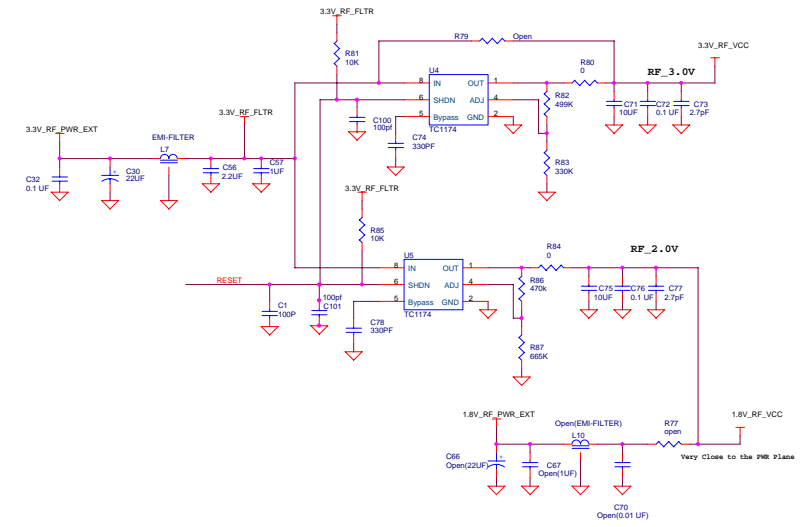

Put close to the OUTIP, OUTIN, OUTQP, OUTQN of the chips and make the interconnect shortest!!!

Make these lines as short as possible with wide space, using top metal. And please shield these lines with clean GND and with large space

50ohm transmission line using top metal!!! (As short as possible!)

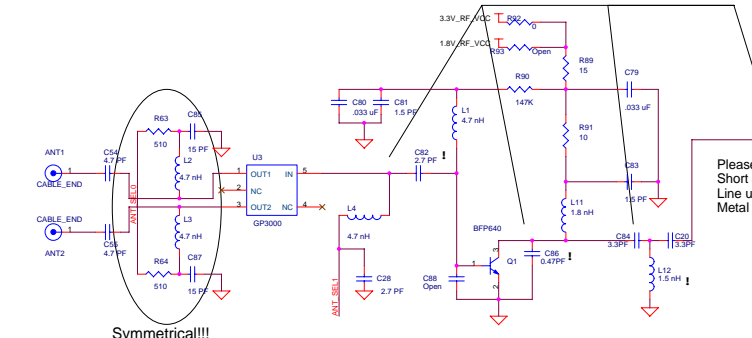

Please Make Short 50ohm Line using top Metal

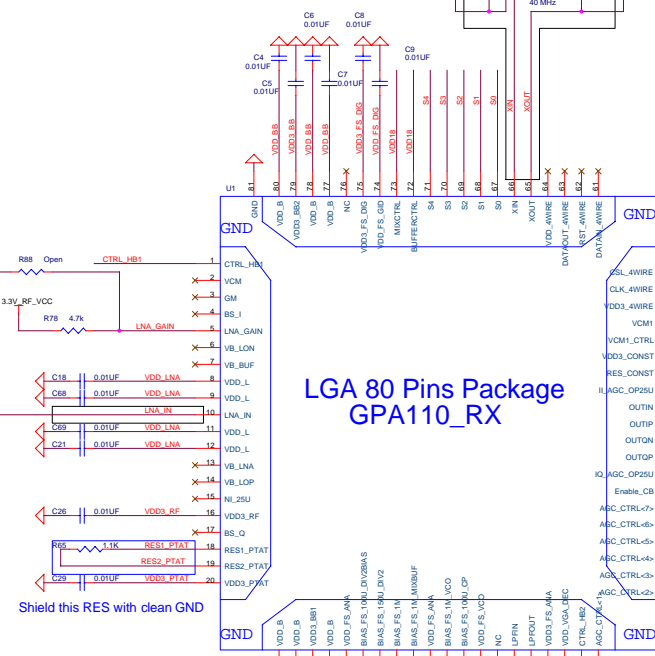

## LGA 80 Pins Package GPA110\_RX

Shield this RES with clean GND

Make these lines as short as possible, and with wide spacing, using top metal. Shield these lines with clean analog GND. Symmetry is very important!!!

Shield this RES with clean GND

Please shield these lines with clean GND

Please shield this LPF with clean GND

Separated Routing for Supply!!!



Please put all the decoupling capacitors close to the chip (with drawing line connection) as close as possible. The VDDs are the most important lines.

# RTD210 TRANSMITTER SCHEMATIC

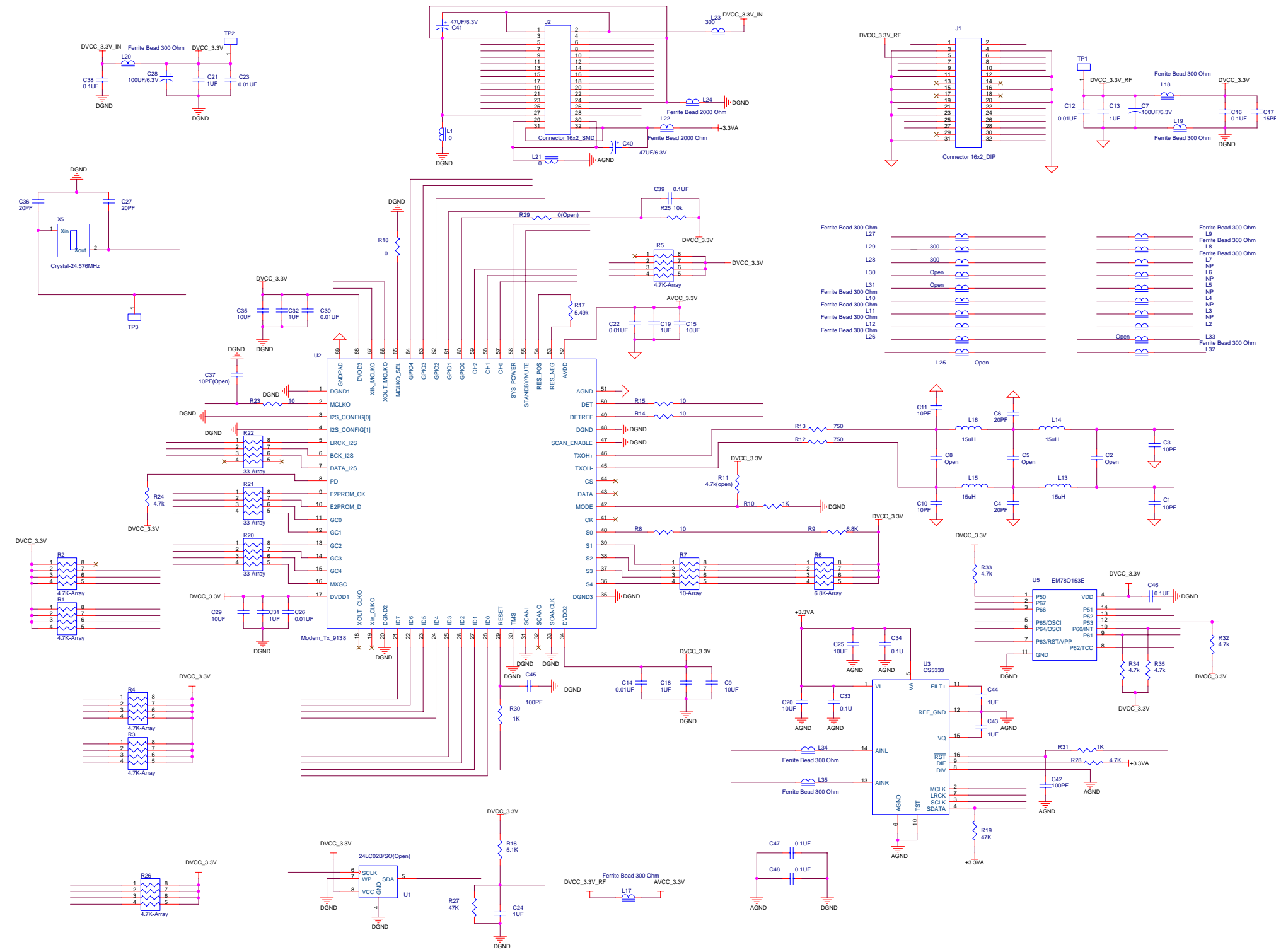

# RTD210 TRANSMITTER AUDIO SCHEMATIC

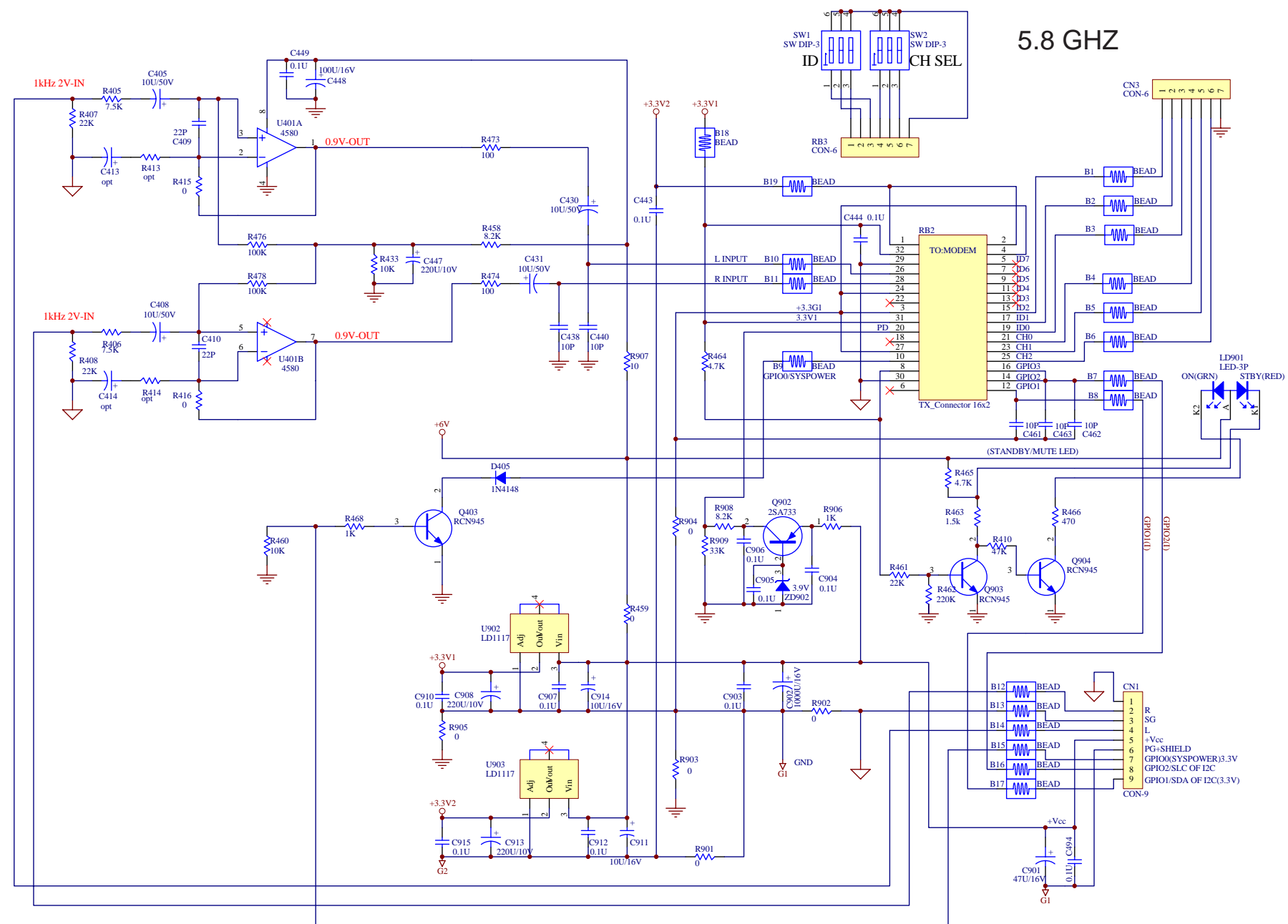

5.8 GHZ

# RTD210 TRANSMITTER RF SCHEMATIC (PG 1)

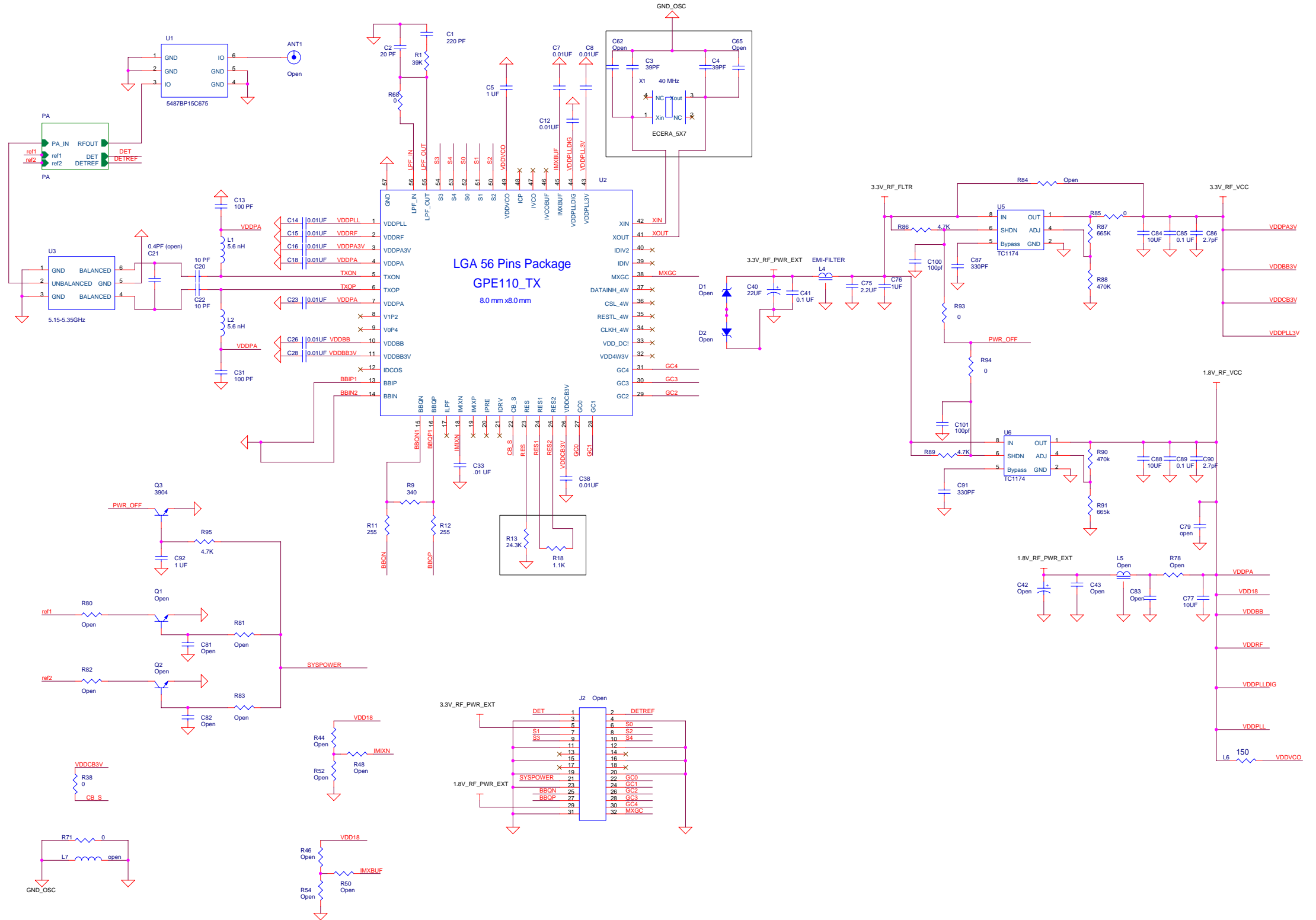

# RTD210 TRANSMITTER RF SCHEMATIC (PG 2)

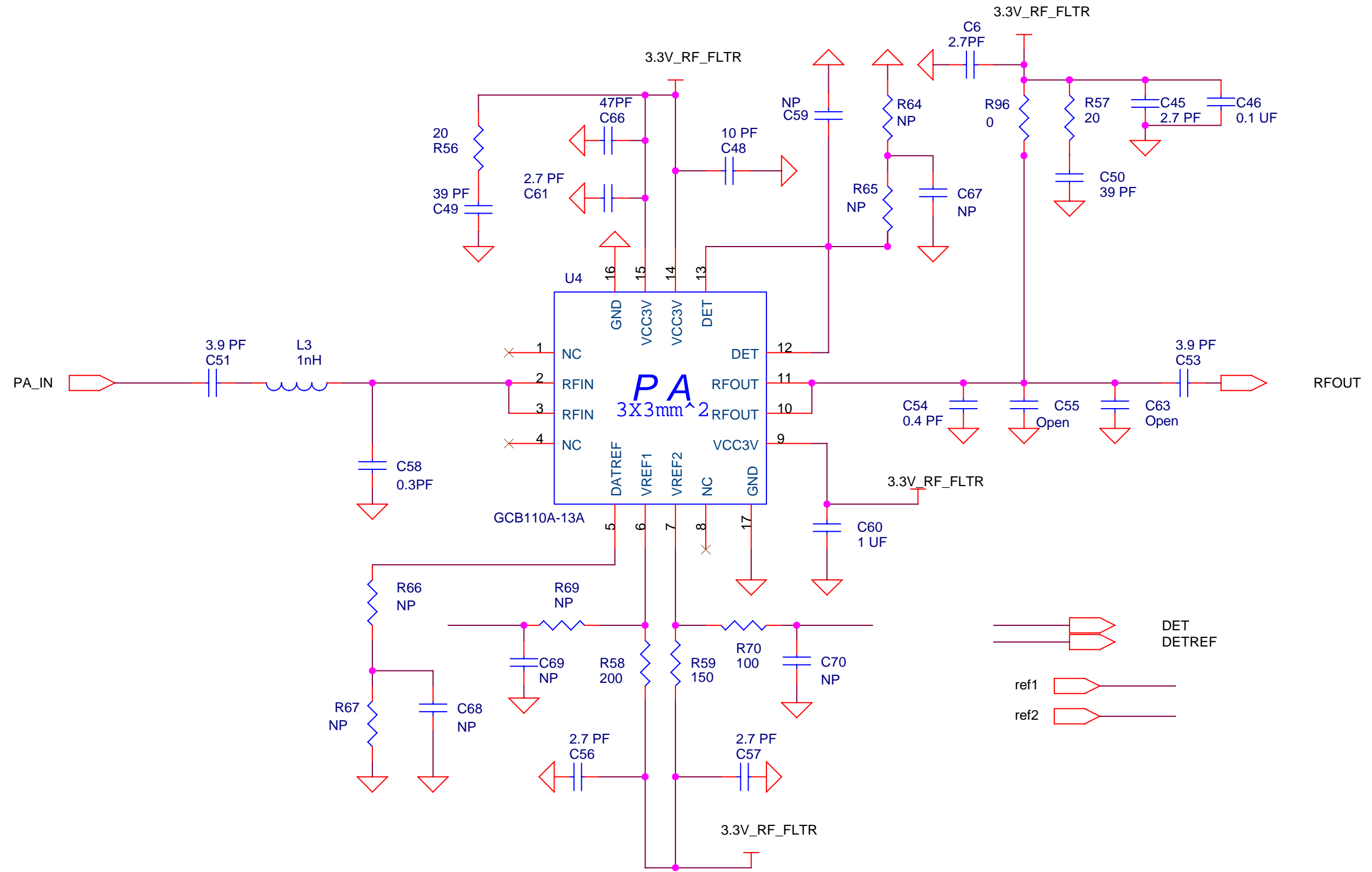

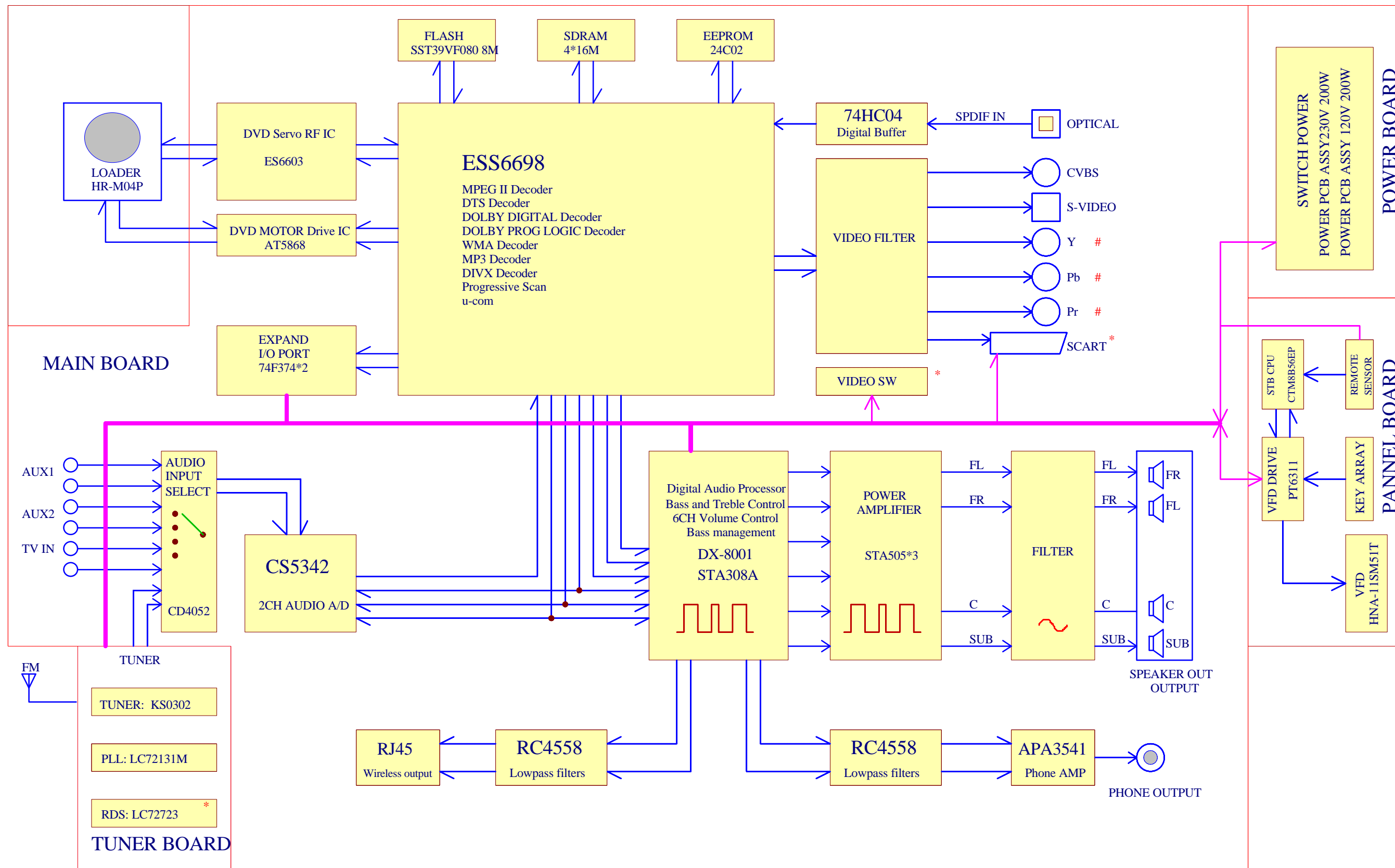

DPL930 / DPL2930 / RTD210 Block Diagram 350W

\*: DPL930  
 \*: DPL2930  
 #: RTD210

# RTD210 WIRING DIAGRAM

SEE PAGE 2 FOR CONNECTOR PINOUTS

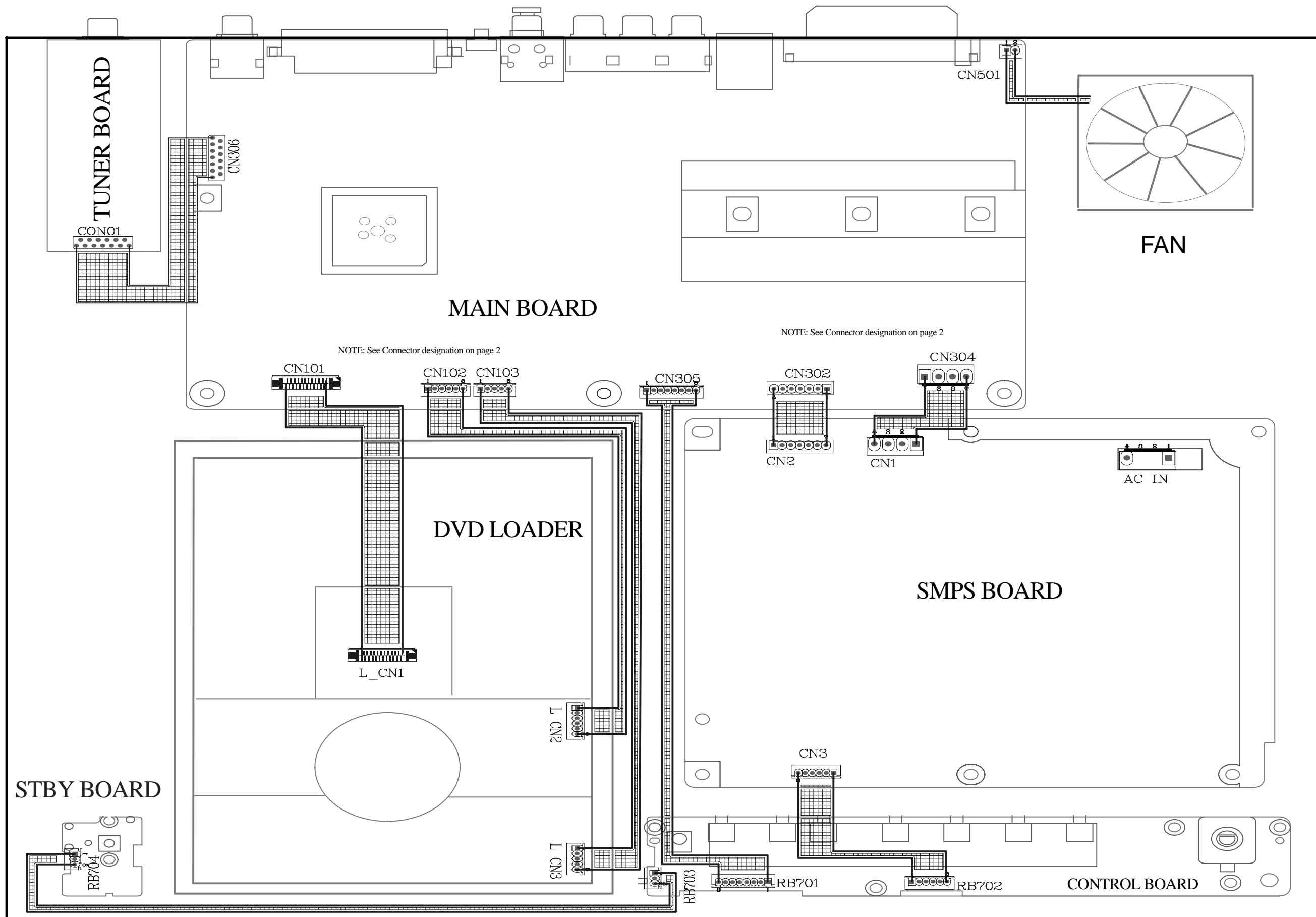



# RTD210 CONNECTOR PINOUTS

CN101

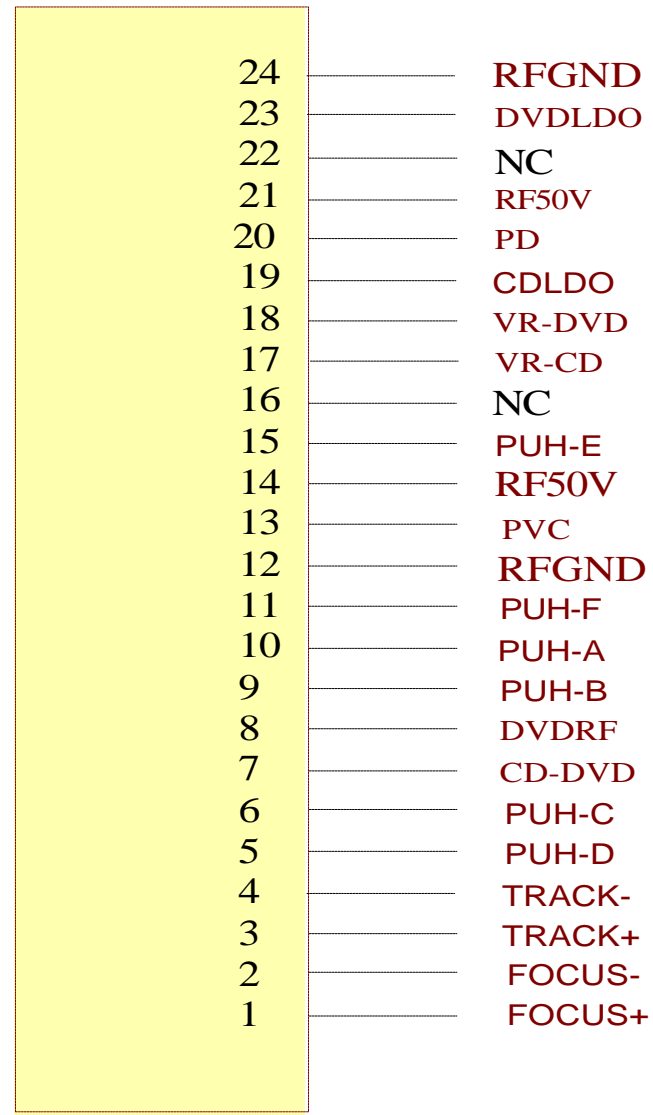

CN102

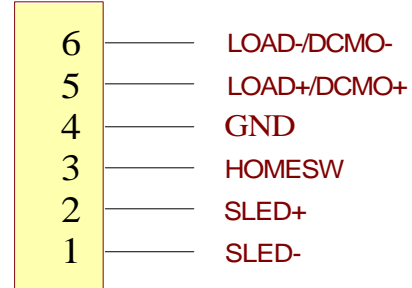

CN103

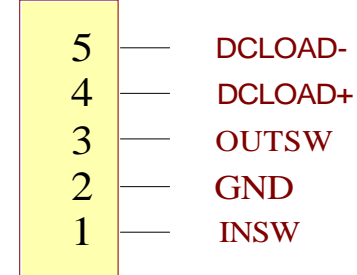

CN104

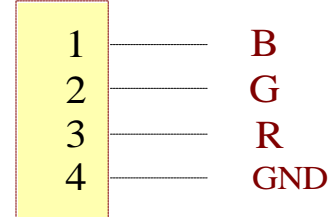

CN301



CN302 / CN2

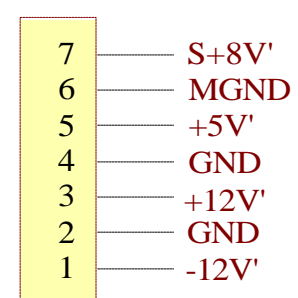

CN303

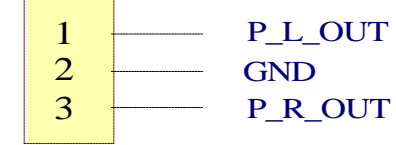

CN305

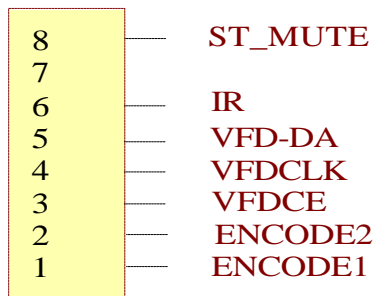

CN306

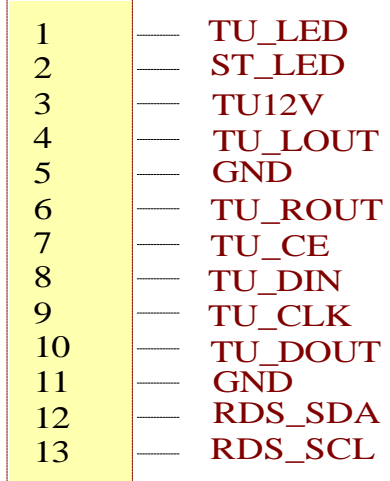

RB801

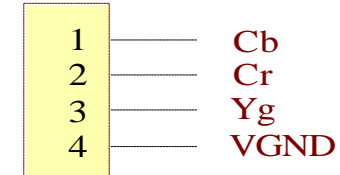

RB701

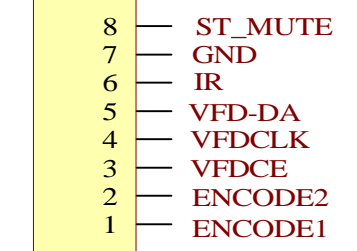

RB702 / CN3

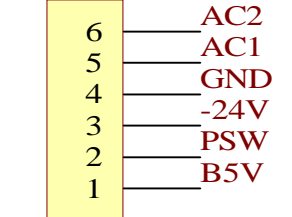

RB703

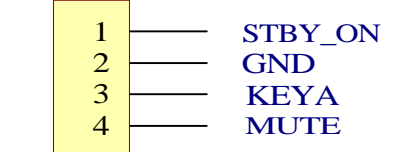

RB704

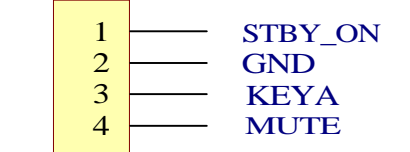

RB705

