

THORENS TD 124 I/II

SERVICE MANUAL

ELPA MARKETING INDUSTRIES, INC.
NEW HYDE PARK, NEW YORK 11040

RUMBLE AND NOISE LEVEL

The following preliminary remarks should first be made:

- A perfectly silent running turntable does not exist. The widely extended bass reproduction of today's best loudspeakers and amplifiers may accentuate the turntable noise level.
- The noise level present on the pressed records currently available is at least equivalent, but in most cases superior, to the rumble level of a TD 124 model turntable.
- A direct recording lacker alone, specially cut on one of the best recording machines presently available, should be used for measuring or evaluating the rumble level of a good turntable.
- The objective measurement of the rumble level, of a turntable, is not a simple matter. It requires elaborate laboratory instrumentation and extreme care. But furthermore, the results will be widely different according to the measurement method employed. The THORENS TD 124 turntables are measured according to the DIN standards.

NORMALIZED AUDITION CONDITIONS

Every objective evaluation of the rumble and noise level of a turntable requires that well defined, audition conditions be realized.

A record should be selected, for auditioning, that is widely accepted as an excellent orchestra recording and not one with an overall too low level and lacking in bass. Then, playing a Fortissimo passage, the volume control should be adjusted to

obtain complete musical pleasure, without any disturbing element. The bass control on the preamplifier should be adjusted to obtain as natural a sound as possible. For well designed equipment, this should be attained very near to the theoretical equalization characteristics ("0" positions of the bass and treble controls).

These adjustments of volume and tone controls should not be modified for the rumble level evaluation which should be made, when a special test record is not available, on the very first non-modulated grooves of a good record, before the groove where the recording amplifier has been switched on, and then on a passage with minimum recorded level.

Furthermore, the evaluation should be made from the place in the room where best musical results are obtained and not just near a loudspeaker.

If, under these conditions, the rumble level of a turntable is judged disturbing, the following tests may help to trace the cause of the trouble.

Under normal listening conditions, first verify if

- A. the abnormal noise persists when the pick-up is lifted from the record, or
- B. the abnormal noise ceases when the pick-up is lifted from the record.

IN CASE A, CHECK SUCCESSIVELY THE FOLLOWING POINTS:

1. Stop the turntable and its motor. Move the pick-up from its rest position towards the center of the turntable and

up and down above the record. If the level of the noise changes appreciably according to the position of the pick-up, it may be concluded that the pick-up cartridge is under the influence of the stray flux from the power transformer of the amplifier or of another associated equipment. The turntable should be taken away, as far as possible, from the source of the hum, and the best relative position and orientation of each element should be determined. If the available space is limited, a cartridge with maximum shielding should be adopted.

2. If the hum level is practically unaffected by the change in the position of the pick-up, the turntable should be disconnected from the preamplifier and the corresponding "pick-up" inputs short-circuited with suitable, well shielded, coaxial plugs. If, under these conditions the abnormal hum persists, the cause should be sought in the preamplifier or amplifier.

If the abnormal hum ceases, the complete wiring between the turntable and the preamplifier should be checked: insufficient or interrupted shielding, or lack of a ground connection, ground loop, inversed polarity on the power supply. For stereophonic circuits, the ground connections should be thoroughly checked according to the precise instructions of the manuals for the cartridge, tonearm and amplifier.

IN CASE B, THE VERIFICATIONS SHOULD BE CONTINUED AS FOLLOWS:

PRELIMINARY REMARK:

For the TD 124 turntable, it is not advisable to evaluate the rumble level by bringing the pick-up on a stopped record with the clutch control in the "off" position. The aluminum turntable is then lifted above the cast iron flywheel and in a fairly unstable position which can emphasize vibrations.

1. Check the voltage of the power supply and the position of the voltage commutator on the turntable.

2. Check the motor resilient suspension on the chassis plate:

- the three posts supporting the motor should be perfectly free inside the three rubber dampers (FD 81) fastened to the chassis plate.

- the thrust washers (F 1033), at the top of the three posts, should not have been pulled away or distorted by a shock.

- the motor should not come into contact with the cabinet, the accessory base or any other part of the installation.

- the wires between the voltage commutator and the motor should be in a position granting the maximum compliance.

3. The lower thrust bearing, of the motor, should not have been partially pulled away from the lower carter by shock.

After a change in the power supply frequency, the motor pulley (CB 874) should be fastened on the motor spindle according to the special instructions of the manual. See that this pulley is not touching the triangular plate set underneath.

4. Check the lubrication of each revolving part in the turntable drive according to the instructions of the owner's manual or the lubrication chart.

The bearing of the stepped pulley (first model with removable spindle CB 774; later models with the spindle fastened to the pulley CB 1351) should be particularly well lubricated with our special ROG oil.

5. The following parts should be entirely free from any trace of oil, or grease, on their working surfaces: the motor pulley, the stepped pulley, the idler wheel, the rubber belt and the inner skirt of the turntable. They should be thoroughly cleaned with a clean rag impregnated with alcohol.

The rubber belt, CB 908, should not stick on the pulleys. Rubber traces, on the pulleys, should be removed with alcohol.

6. Check that the rubber tire, of the idler wheel (CB 763), precisely ground at the factory, has not developed a flat spot. The idler wheel should rotate without any vibration, when it is slightly pressed against the stepped pulley.

Check that the support of the idler wheel is perfectly free at all its articulations.

After all these verifications have been successfully performed, the only remaining cause of an abnormal rumble level still to be imputed to the turntable, could be a deformation of the rotor spindle of the motor, an extremely rare case. When removing the

rubber belt, the rumble level would then remain practically the same.

But in the great majority of cases, it will be found that an objectionable rumble level is the result of an uncomplete installation of the whole system.

ACOUSTIC FEEDBACK

The very low frequency sounds coming out of the loudspeakers may transmit appreciable vibrations to the turntable. The cabinet supporting this turntable, acting as a resonator, may amplify these vibrations. This will result in higher rumble level and, in some cases, in instability or feedback.

1. The resilient shock mount of the turntable should first be examined, following exactly the instructions of the mounting template. An error in cutting, or drilling, the mounting panel will compromise the damping of vibrations.
2. The normal shock-mount, of the turntable, may not be sufficient in certain cases. A higher resilience, but lower damping, may be obtained for the TD 124 turntable by making use of special springs (parts number CB 962 and CB 1172).

But best protection against acoustic feedback and floor vibrations will be obtained when mounting the wooden panel supporting the turntable, or the accessory base, freely on thick foam rubber cushions.

But, if the cabinet is acting as a resonator, it may become necessary to find another place for the turntable if

complete stability is to be obtained.

SERVICE PROCEDURES

RUBBER BELT - CB 908

FIGURES: 1,2

Examine the rubber belt by stretching it. If cracks appear in the rubber, the belt is dried out and should be replaced. Before replacing the belt examine the surfaces of the motor pulley (CB 874) and the step pulley (CB 1351) for traces of rubber deposits. Clean these surfaces with a soft cloth saturated in denatured alcohol and replace the belt.

If the rubber belt makes a "slapping" noise, too much moisture in the belt may be the cause. Dust your fingers, lightly, with talcum powder and pass the belt through the powder to "dry" it or absorb the moisture.

IDLER WHEEL - CB 763

FIGURES: 1,2

Examine the "running" edge of the idler wheel for cracks in the rubber, dents or "flat spots". If these are observed, replace the idler wheel.

Check the play, of the idler wheel, on the spindle. If it is excessive and "rocks" on the spindle, replace the idler wheel and check the spindle for signs of wear.

Examine the nylon washer (F 1323) beneath the idler wheel. If the surface of the nylon washer appears scored, reverse it on the spindle or replace it.

On the TD 124 SERIES I, when replacing the idler wheel, ascertain

that a minimum of 1/64" play is left between the idler bushing and the lock ring.

MOTOR - ME 380

The motor bearings are of the oil retaining type with a large oil reserve in the felt pads. Under normal use, the initial lubrication, made at the factory, should be sufficient for about 5,000 hours' run. When the need for a new lubrication becomes apparent, proceed as follows:

MOTOR UPPER BEARING

Place a few drops of ROB oil on top of the bearing, where the shaft comes out of the top motor shield.

MOTOR LOWER BEARING

Oil should be put on the lower part of the shaft, underneath the rotor. This lower part can be reached with a pressure oil can through the lubrication hole, on the side of the bottom motor shield.

MOTOR SUSPENSION

The motor should hang freely on the three suspension points. In time, the rubber grommets (FD 81) may become dry and lose their resiliency. When this occurs, the rubber belt (CB 908) may have a tendency to slip off the pulleys. The rubber grommets (FD 81) should be replaced. If, after replacement, the belt still slips off the pulleys

the azimuth of the motor in relation to the step pulley may have to be corrected. This may be done by adding washer spacers between one or two of the rubber grommets and the "C" clip.

BEARING WELL - CB 761/TURNTABLE SHAFT - CB 779

FIGURE: 2

Older models, of the TD 124 SERIES I (since 1958), employed a bearing well (CB 761) with a black, nylon insert bushing. This part, it had been found, may deform and expand after extensive use. The bearing well (CB 761) should be replaced with the new type containing a scintilated bronze insert bushing.

The teflon thrust plate, at the bottom of the bearing well, should be examined for dents, or deformations, of the surface. Examine the turntable shaft (CB 779) for evidence of wear.

The condition of the bearing well and turntable shaft, and their lubrication, may be checked, over a period of time, by noting, periodically, how many revolutions may be counted from the moment the power is turned off (from full running speed) until the turntable stops. If the count drops radically, the lubrication or replacement of either, or both, parts is indicated.

CLUTCH - CB 759

FIGURES: 2,3

OPERATION:

When the clutch lever (CB 759) is operated, a sythe-shaped lever is raised up on three pins (M7X28F49) raising the aluminum turntable cover (CB 802) off the inner turntable

(CBE 757/CB 788).

ADJUSTMENTS:

If the aluminum turntable (CB 802) becomes warped, it may, when raised, scrape the inner turntable (CBE 757/CB 788) or when lowered scrape the clutch lever (CB 759) and should be replaced. If the aluminum turntable cover is not warped, then adjustment of the three pins (M7X28F49) may be necessary. Loosen the lock nuts (M7VSM-12699) and adjust the pin by turning the slotted screw corresponding to the source of the scraping, in or out as required. After each adjustment check, with the clutch in and out, for a scraping noise.

ON-OFF SWITCH - CBE 787

FIGURE: 3

If the on-off switch fails to operate, remove the unit from AC and check the contacts with an ohmmeter, operating the actuating lever (CB 770) by hand. The speed selector knob should be in one of the "on" (speed) positions. If the switch makes continuity but the actuating lever movement is insufficient to actuate the switch, loosen the two lock nuts securing the plunger at the end of the lever and adjust the plunger. On TD 124 SERIES II, the actuating lever switch adjustment is made by moving the position of the cam roller on the actuating lever.

The reverse procedure to the above should be followed if the unit fails to shut off. The 0.01 ufd condenser should also be tested for a short.

If a "popping" noise occurs in the speakers when the on-off switch is operated, the 0.01 ufd condensor may be open and should be replaced.

NEON BULB - AE 269

FIGURE: 3

The neon bulb receives its operating voltage through a 33K ohm, 1/2 watt resistor located within the plastic insulation binding the motor wires together near the terminal block. If the bulb fails to light, when the motor is operating, the resistor should be tested with an ohmmeter. If the resistor tests good, within 10% of value, the bulb may be assumed to be defective.

The neon bulb must be replaced from the underside of the unit plate:

1. Disconnect unit from AC current.
2. Remove the stroboscope mirror by loosening the mounting spring.
3. Remove the retaining plate.
4. Take out the complete bulb assembly and remove the plastic sleeve.

NOTE: When replacing the mirror do not permit the mounting spring to snap with force against the back of the mirror.

FINE SPEED ADJUSTMENT

FIGURE: 2

Fine speed adjustment is accomplished through eddy current forces by altering the position of a vane located beneath the rotating

step pulley (CB 1351) in relation to a magnet (CB 921) set at the perimeter of the step pulley. The range of the fine speed control, plus or minus 3% of mean speed, may be altered by relocating the brake magnet closer or further away from the step pulley.

STEEL RIBBON - CBE 771

FIGURE: 3

Should the steel ribbon (CBE 771) require replacement, set the speed selector knob to the 78 rpm position and remove the two screws securing the ends of the ribbon and the one screw securing the ribbon to the speed selector wheel. Fasten the new band to the wheel and pass the long end of the ribbon around the cam locating the holes, in the band, over the cam sprockets. Three sprocket holes, of the ribbon, should remain unoccupied by the cam sprocket pins to the right of where the ends of the ribbon are joined.

50/60 HZ - 110/220 VOLT OPERATION

FIGURE: 2

VOLTAGE COMMUTATOR

The commutator permits adaptation, of the turntable, to the line voltage. For USA and CANADA, the commutator screw is set at the factory for 110 volts 60 cycles (100-120 volts position) on the TD 124 SERIES II. The commutator is protected by an insulating plate that can be removed.

ADJUSTMENT TO THE FREQUENCY OF POWER SUPPLY

FIGURES: 1,2

For USA and CANADA, the motor pulley and the stroboscope screen

have been set, at the factory, in the position for 60 cycle operation.

The adjustment to the frequency of the power supply is made by reversing the motor pulley (CB 831) on the motor shaft. Loosen the two set screws between the pulley sections. The larger diameter is for 50 HZ operation and the smaller for 60 HZ. Reverse the stroboscope screen (CB 821) to unmask the stroboscope pattern to be viewed through the stroboscope mirror.

FIGURE 1

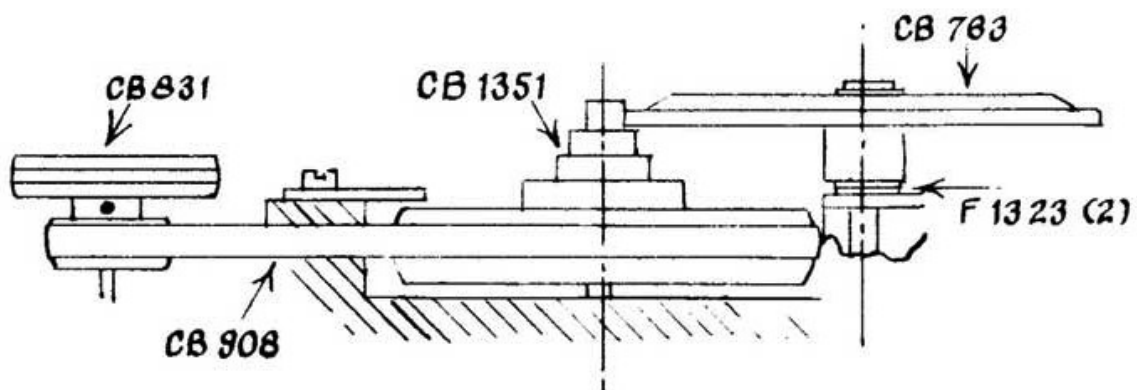

THORENS TD 124 I/II PARTS LIST

CB 756	Aluminum Turntable - Complete
CBE 757	Turntable with Spindle - Ferrous
CB 759	Clutch Lever Series I
CB 759X1	Clutch Lever Series II
CB 761	Bearing Well
CB 764	Second(2) Arm of Idler Wheel Bracket
CB 763	Idler Wheel
CB 768	Switch Lever Adjusting Link
CBE 770	Switch Lever
CBE 771	Steel Ribbon for Speed Change Arm
CBE 776	Speed Change Drum
CBE 777	Current Breaker
CB 779	Turntable Spindle
CBE 782/CB 803	45 RPM Adapter - Complete
CBE 787	Switch
CBE 788	Turntable with Spindle - Non Ferrous
CB 789	Belt Retaining Plate
CB 792	Clutch Washer
CB 802	Aluminum Turntable without Mat
CB 805	Thrust Bearing Washers
CB 806	Thrust Bearing Cover Plate
CB 807	Speed Adjusting Link
CB 811	Brake Magnet Set Plate
CB 812	Step Pulley Stop Plate
CB 814	Steel Ribbon Adjust Link
CBE 816	Idler Wheel Bracket
CB 818	Stop Ring for First (1) Spindle
CB 820	Neon Bulb Retaining Plate

CB 821	Stroboscope Screen
CB 822	Insulation Plate
CB 823	Stroboscope Mirror Retaining Plate
CB 831/CB 874	Motor Pulley
CB 834/CB 941	Spirit Level
CB 855	Sleeve
CB 856	Stop Ring
CB 857	Sleeve
CB 858	Friction Sleeve
CB 871	Mounting Studs
CB 877	Leveling Knobs
CB 906	Speed Change Cam
CB 909	Rubber Grommets
CB 912	Speed Selector Knob
CB 913	Speed Adjusting Knob
CB 914X1	Clutch Control Knob Series II
CB 914	Clutch Control Knob Series I
CB 916	Stroboscope Mirror
CB 921	Brake Magnet
CB 922	Stroboscope Lucite Cover
CB 924	Spring for Idler Wheel Bracket
CB 926	Speed Adjust Knob Spring
CB 927	Clutch Lever Height Adjusting Nuts and Screws
CB 928	Spring for First (1) Spindle
CB 934	Mounting Spacers
CB 935	Base Template
CB 936	Arm Board Template
CB 946	Line Cord

CB 955	Idler Wheel Spindle
CB 956	Step Pulley Spindle
CB 957	Idler Wheel Bracket Spindle
CB 961	Leveling Knobs
CB 963	Switch Suppression Condenser 0.01 ufd
CB 965/CB 908	Rubber Belt
CB 1172	Mounting Springs
CB 1351	Step Pulley - (New Type)
CB 1788/CB 907	Rubber Mat for CB 802
CB 1835	Speed Selector Knob Series II
CB 1836	Fine Speed Adjustment Knob Series II
CB 1870	Voltage Commutator Screw
AE 235J	Power Supply Connecting Block
AE 268	Bulb Socket
AE 269	Neon Bulb
ME 333	Voltage Commutator
ME 380	Motor (E-50)
FD 81	Motor Suspension Device
F 1028	Idler Wheel Fiber Washer
F 1068	Nylon Thrust Plate
F 1191	Washer
VSM 12124 M3X5	Screw, Thrust Bearing Cover Plate
VSM 12124 M5X12	Screw, Spindle
VSM 12124 M5X16	Screw - Turntable Bearing
VSM 12126 M5.20X14	Screw, Brake Magnet Plate
VSM 12140 M3X8	Screw, Clutch Control Knob
VSM 12707 M5	Nut, Mounting Stud
100.35.161 ni	Screw, Idler Wheel Retainer
100.35.181 ni	Screw, Strobe Mirror Plate

FIGURE 2

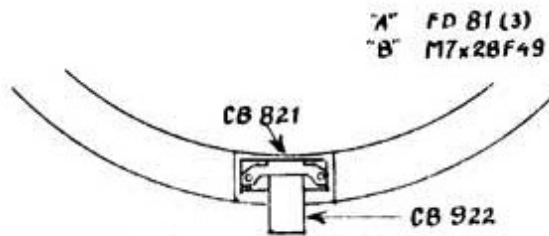
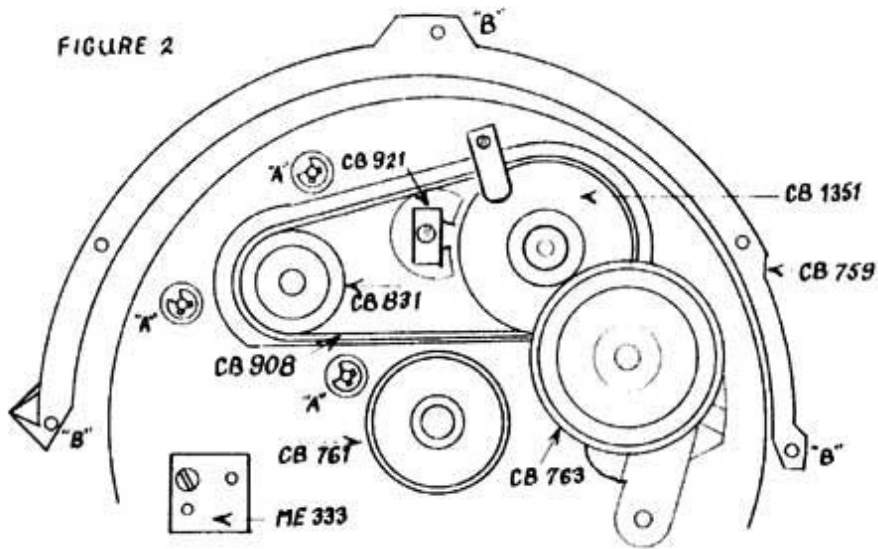

FIGURE 3

