

ALIGNMENT PROCEDURE

The following equipment is required for alignment:

1. Signal generator with a frequency range of a least from 455KC to 12.5MC, AM.
2. Vacuum tube volt meter.
3. Test Loop, a coil of any size wire, one turn or more.
4. For alignmentst points see schematic.

NOTES:

During alignment keep the signal generator outputs at the lowest level that will maintain a useable output from the set.

Ground connection of signal generator.....chassis ground

Generator modulation30%, 400 %

Step	Generator Connction	Generator Frequency	Band Setting	Position of Tuning Gang	Meter or Oscilloscope Connection	Adjustment	Remarks
------	---------------------	---------------------	--------------	-------------------------	----------------------------------	------------	---------

MW ALIGNMENT

1.	Test Loop	455KC	MW	Tuning Gang fully closed	Across Voice Coil	T1, T2, T3	Abjust for maximum
2.	Same	~ 525KC	MW	Same	Same	L3 MW (Osc. Coil)	Same
3.	Same	1660KC	Same	Tuning Gang fully open	Same	C2c MW (Osc. Trimmer)	Same
4.	Repeat Step 2 and 3						
5.	Same	600KC	Same	600KC	Same	L1 MW (Ant. Coil)	Same
6.	Same	1400KC	Same	1400KC	Same	C2a MW (Ant. Trimmer)	Same
7.	Repeat Step 5 and 6						

SW ALIGNMENT

1.	Test Loop	3.75 MC	SW	Tuning Gang fully closed	Across Voice Coil	L2 SW (Osc. Coil)	Adjust for maximum
2.	Same	12.5 MC	Same	Tuning Gang fully open	Same	C2d SW (Osc. Trimmer)	Same
3.	Repeat Step 1 and 2						
4.	Same	4 MC	Same	4 MC	Same	L1 SW (Ant. Coil)	Same
5.	Same	11 MC	Same	11 MC	Same	C2b SW (Ant. Trimmer)	Same
6.	Repeat Step 4 and 5						

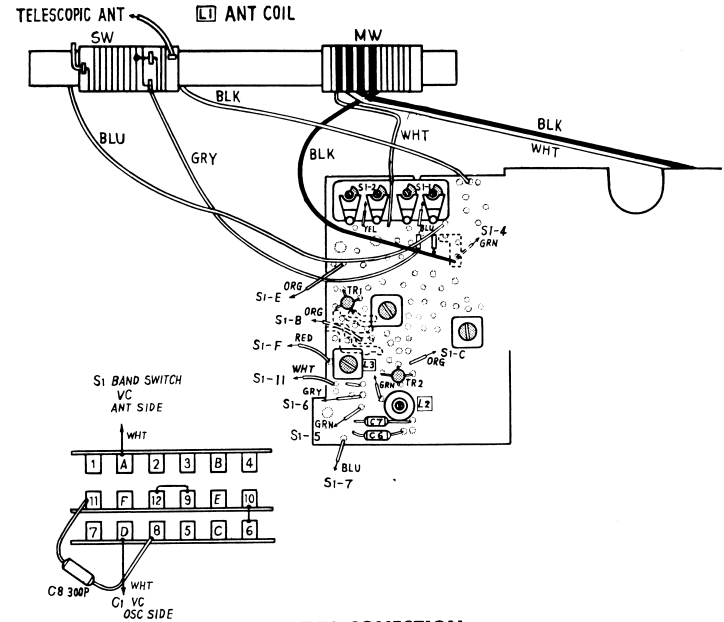

BAND SWITCH CONECTION

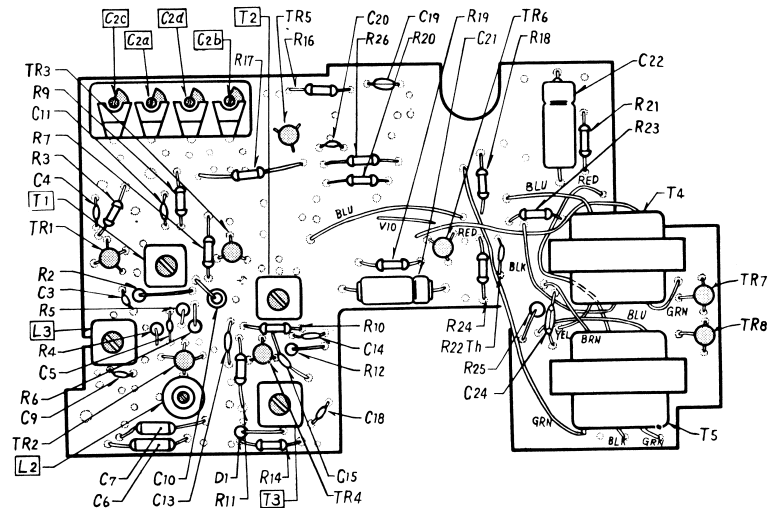

TOP VIEW

TOSHIBA TOSHIBA TRANSISTOR RADIO
SERVICE MANUAL

SPECIFICATIONS

FREQUENCY RANGE: MW 540-1600KC
SW 38-12MC
INTERMEDIATE FREQUENCY: 455KC
POWER SOURCE: UM-2A (*C) × 4... (6V)
POWER OUTPUT: 350mW
SPEAKER: 3½" PMD Speaker
ANTENNAS: Ferrite Core Antenna (MW and SW) and 7 Section Telescopic Antenna for SW

TRANSISTORS & DIODE:
2SA 469 or 2SA 93 Mixer 1
2SA 468 or 2SA 92 Local Oscillator 1
2SA 49 IF Amplifier 1
2SA 53 " " 1
2SB 54 AF Amplifier 2
2SB 56 Power Amplifier 2
1N 60 Detector and AGC 1
DIMENSIONS: W...9" H...5¾" D...2½"
WEIGHT: 2.9 lbs. with Batteries

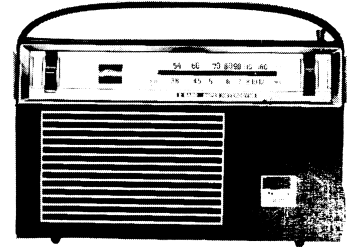

SCHEMATIC DIAGRAM

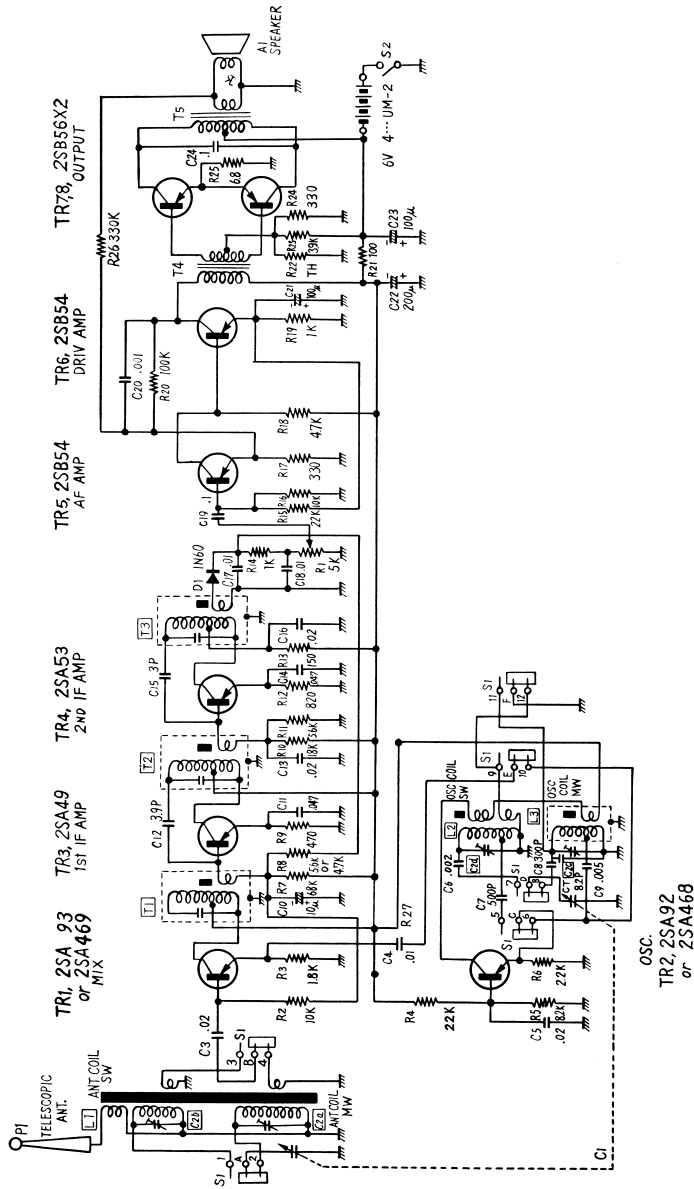

CHASSIS REMOVAL

1. Remove the back cabinet.
2. Remove the two nuts marked (★) and the two screws marked (※) shown in the diagram.

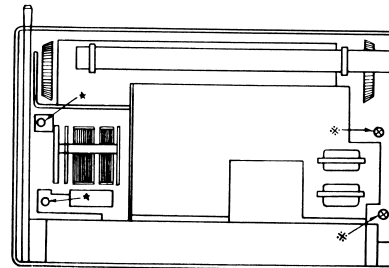

DIAL CORD ARRANGEMENT

1. Set the variable capacitor to the maximum capacitance. (Close)
2. Set the cord as number in the diagram. Carefully pull the chassis from the cabinet Remarks: When separating the chassis, do not loosen any screw (nut) except the ones pointed with white enamel.

