



センターファイル
Center File

TOSHIBA

STEREO RADIO CASSETTE PLAYER

KT-4036/V630

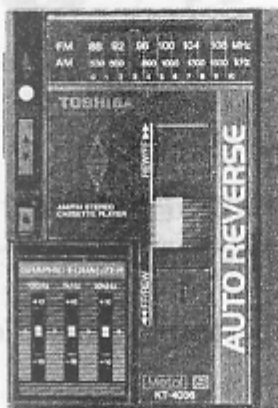

KT-4036

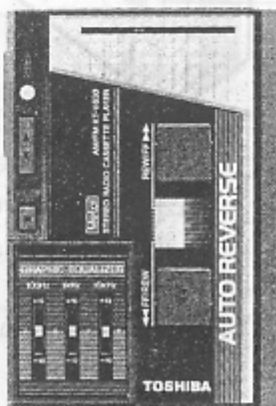

KT-V630



SPECIFICATIONS

Track system:	Stereophonic	Antenna:	FM: Headphones cord AM: Ferrite-core antenna
Recommended tape:	Normal ferric, chrome dioxide, and metal alloy: C-30 to C-90 (Recorded tape)	Output terminal:	3.5mm dia. stereo headphones jack x 1
Tape speed:	4.8 cm/sec.	Maximum output power:	Integration 60mW (30mW + 30mW)
Frequency response:	Reproduction: 40 Hz to 14 kHz (normal), 40 Hz to 16 kHz (METAL/CrO ₂)	Power supply:	3V DC (IEC R6 "AA" cell x 2) External power source supplied to the [DC IN 3V] jack (3.4mm dia. center contact negative)
Graphic equalizer:	100 Hz, 1 kHz, 10 kHz	Dimensions:	84(W) x 122(H) x 36(D) mm
Receiving frequency:	FM: 88 MHz to 108 MHz AM: 526.5 kHz to 1606.5 kHz	Weight:	265g (without batteries)
Intermediate frequency:	FM: 10.7 MHz AM: 455 kHz		

Specifications are subject to change without notice.

4036-K-TA, TC, V630-K-VF

1. OPERATING CONTROLS

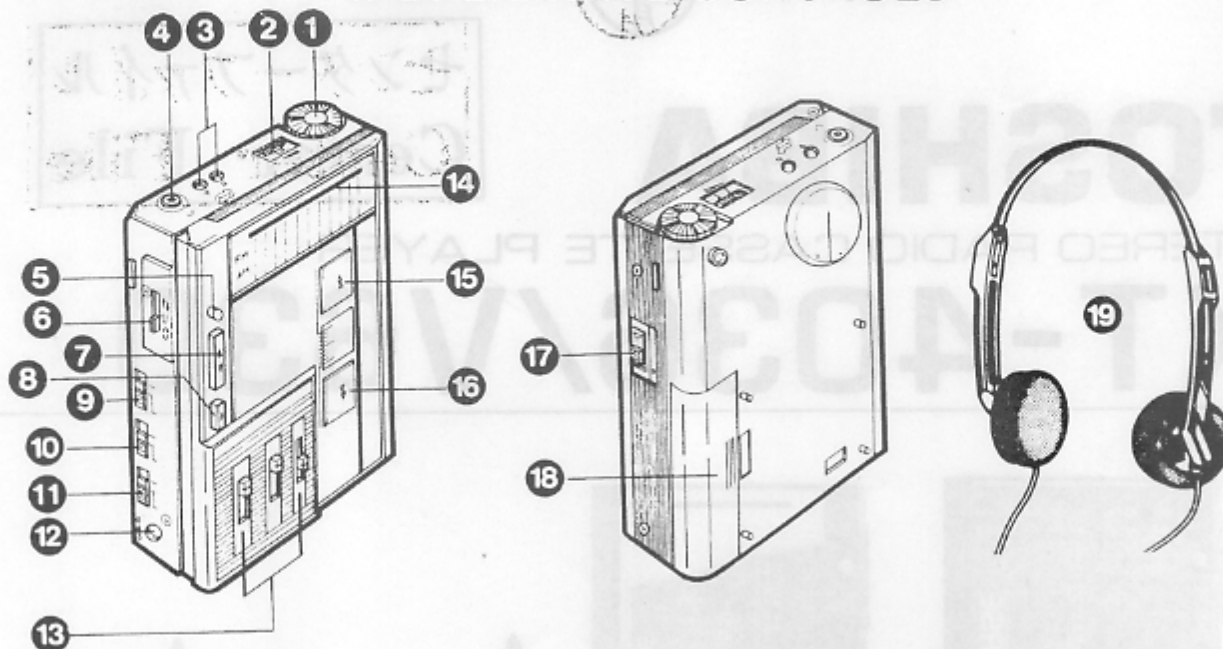

- 1 [TUNING] knob
- 2 [VOLUME] control
- 3 [BATT] battery indicator/[▲ FWD, ▼ REV] tape direction indicator
- 4 [PHONES] jack
- 5 [MANUAL] button
- 6 [REVERSE MODE] switch
- 7 [◀▶PLAY] button
- 8 [■ STOP] button
- 9 [FM-ST, FM-MONO] FM mode switch

- 10 [METAL/CrO₂, NORM] tape selector [FM, AM] band selector (dual operation)
- 11 [RADIO, RADIO OFF /TAPE] function selector
- 12 [DC IN 3V] jack
- 13 [GRAPHIC EQUALIZER] controls
- 14 Tuning pointer
- 15 [REW/FF] button
- 16 [FF/REW] button
- 17 [OPEN] button
- 18 Battery compartment lid
- 19 Headphones

Note: Pressing the [OPEN] button will slightly open the cassette lid. When loading or unloading a cassette, open the lid fully with your hand.

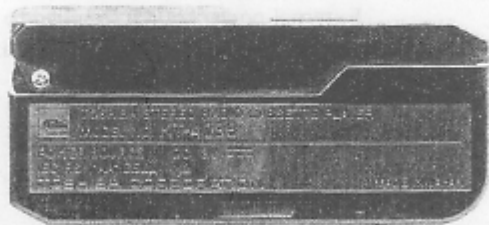

Name Label KT-4036



Name Label KT-V630

2. DIAL CORD RESTRINGING

1. Knot dial cord once so that the specified length is obtained. Insert one end of the cord into ring part of spring and tie the cord two times. (Make three knots in total.)

Note: No slack in the knots of dial cord.

2. Apply adhesive #573 3mg to the knots.
3. Pull dial cord from drum.
4. Proceed to cord restringing in steps ① to ⑦.
5. Set pointer to "0" position of dial scale.

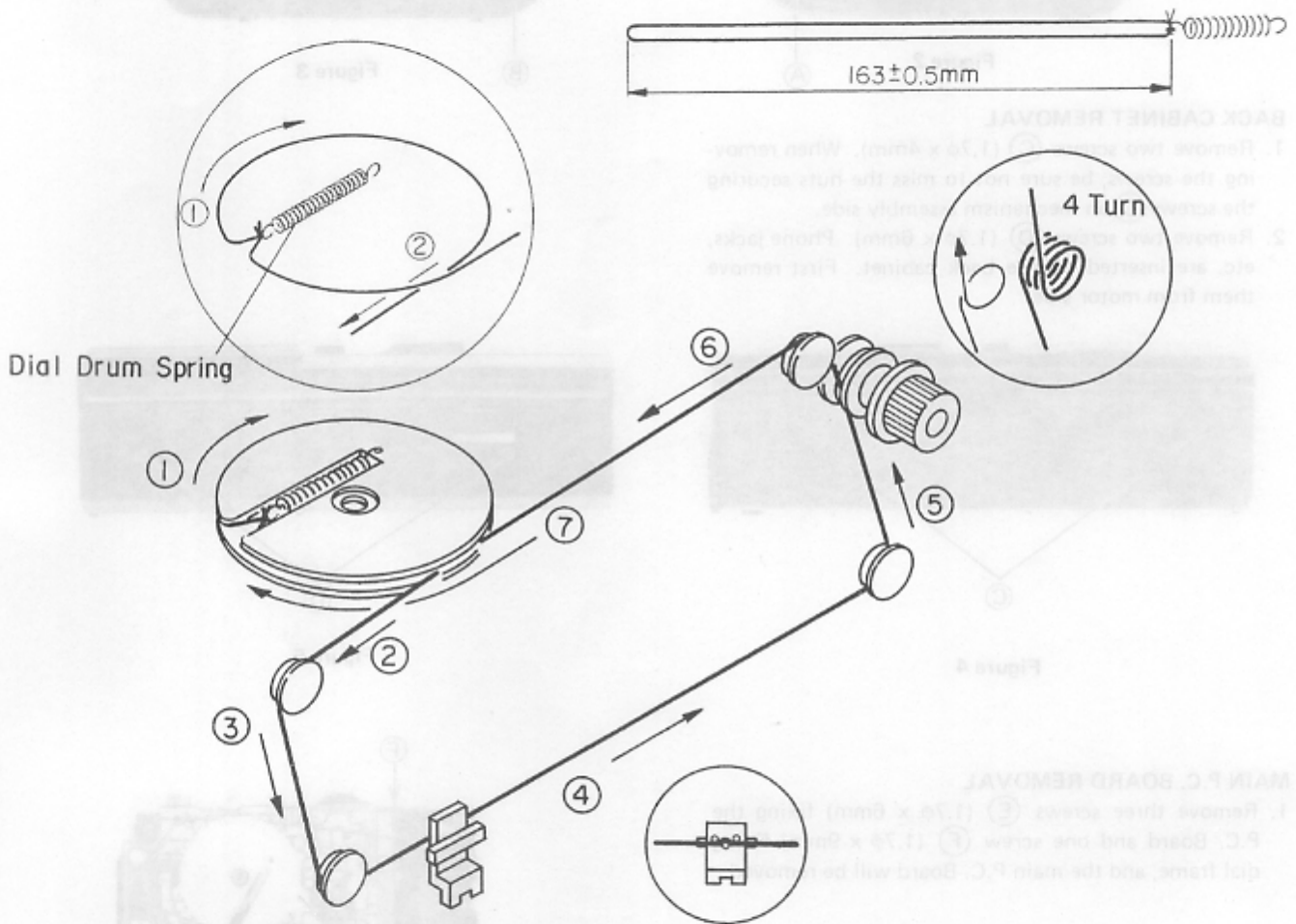

Figure 1

3. DISASSEMBLY INSTRUCTIONS

FRONT CABINET REMOVAL

1. Remove two screws (A) and (B), and the front cabinet will be removed.



Figure 2

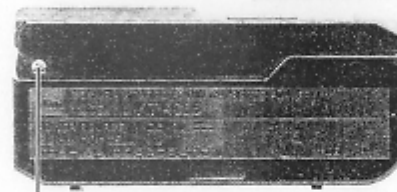

Figure 3

BACK CABINET REMOVAL

1. Remove two screws (C) (1.7φ x 4mm). When removing the screws, be sure not to miss the nuts securing the screws (C) on mechanism assembly side.
2. Remove two screws (D) (1.7φ x 6mm). Phone jacks, etc. are inserted on the back cabinet. First remove them from motor side.



Figure 4

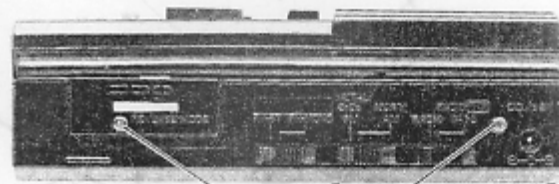

Figure 5

MAIN P.C. BOARD REMOVAL

1. Remove three screws (E) (1.7φ x 6mm) fixing the P.C. Board and one screw (F) (1.7φ x 9mm) fixing dial frame, and the main P.C. Board will be removed.

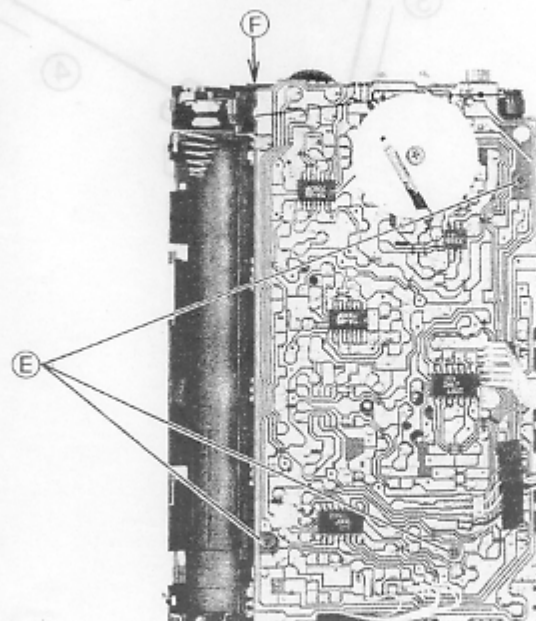

Figure 6

4. ADJUSTMENTS

TEST EQUIPMENT

1. AM Signal Generator with a frequency range of at least from 450 kHz to 13 MHz.
2. FM Signal Generator with 10.7 MHz marker signal.
3. AM Sweep Generator of 455 kHz center frequency.
4. FM Sweep Generator with a wide band amplifier of approximate 500 kHz, with 10.7 MHz marker signal.
5. Oscilloscope with a wide range amplifier of approximately 100 kHz.
6. Loop Antenna. (AM)
7. Test loop – a three turn loop antenna of 10 mm diameter. (FM-IF)
8. Test loop – a coil of any size wire with one turn or more. (AM-IF)
9. VTVM.
10. 75 ohm dummy antenna. (FM)
11. Adjustment Screwdriver.
12. Electrolytic capacitor, 3.3mfd, 50V/25V, M (AM)

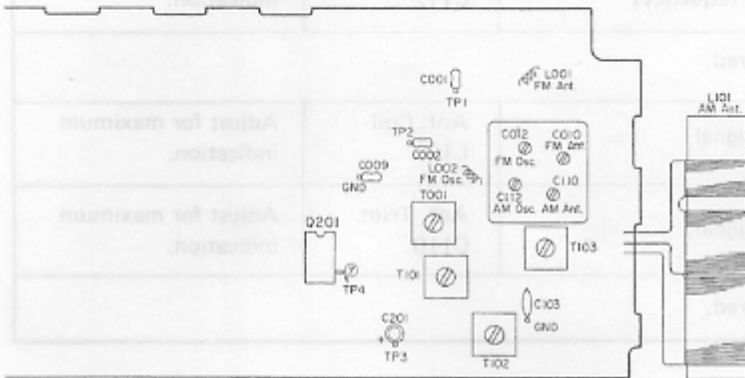

Figure 7

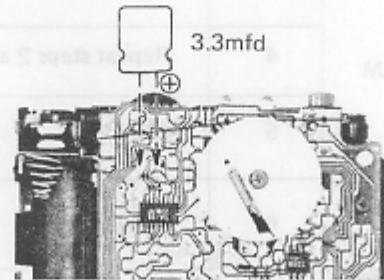

Figure 8

AM ALIGNMENT

1. Set the Select SW to AM position.
2. Turn on the AM signal generator, sweep generator, and the VTVM allowing a fifteen-minute warm-up period. (Solder 3.3mfd capacitor across the point and GND shown in Figure 8.)
3. First, do the AM-IF Alignment (AM ALIGNMENT CHART), referring to Figure 9.
4. Using the loop antenna across the output of the signal generator, inductively connect the signal generator to the radio. (Figure 10)
5. Connect the VTVM across the Headphone Jack.
6. Set signal generator frequency as listed in ALIGNMENT CHART and maintain a sufficient output level to provide an indication on VTVM.
7. Set volume control at mid-position.
8. Unsolder 3.3mfd capacitor.

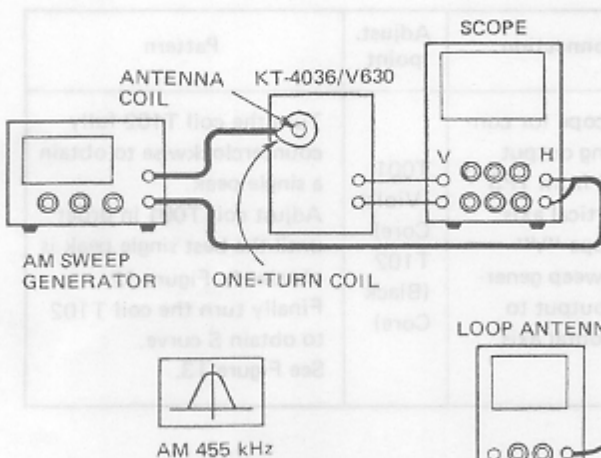

Figure 9

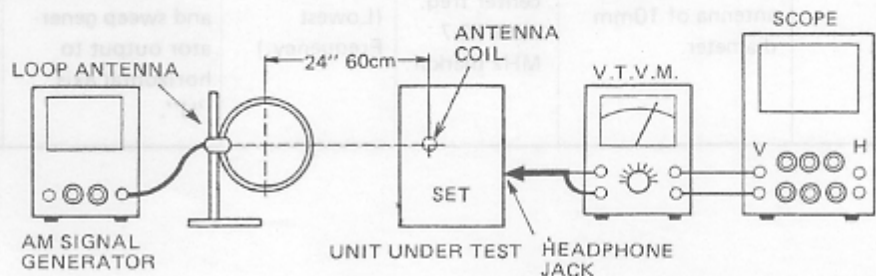

Figure 10

AM ALIGNMENT CHART

Band	Step	Signal Generator Frequency	Radio Dial Setting	Adjustment	Remarks	
AM-IF	1	455 kHz	Tuning Gang Fully Counter-clockwise (Lowest Frequency)	T101	Adjust coil T101 and T103 until best signal peak is obtained.	
AM	2	515 kHz	Tuning Gang Fully Counter-clockwise (Lowest Frequency)	Osc. Coil T103	Adjust for maximum indication.	
	3	1650 kHz	Tuning Gang Fully Clockwise (Highest Frequency)	Osc. Trim. C112	Adjust for maximum indication.	
	4	Repeat steps 2 and 3 as required.				
	5	600 kHz	Tune to Signal.	Ant. Coil L101	Adjust for maximum indication.	
	6	1400 kHz	Tune to Signal.	Ant. Trim. C110	Adjust for maximum indication.	
	7	Repeat steps 5 and 6 as required.				

FM-IF ALIGNMENT

1. Set the select switch to FM position.
2. Turn on both sweep generator and oscilloscope, and allow a fifteen-minute warm-up period.
3. Connect the RF SWEEP SIGNAL OUTPUT of the sweep generator through the loop antenna to the receiver. (Figure 11)
4. Connect the oscilloscope vertical input (through the resistor (more than 22K ohm)) to the test point TP3 and connect the shielded lead to the ground line.
5. Connect the SWEEP VOLTAGE OUTPUT of the sweep generator to the oscilloscope Horizontal input.
6. Proceed as outlined in the FM-IF ALIGNMENT CHART.

FM-IF ALIGNMENT CHART

Step	Signal coupling	Equip.	Tuning	Connection	Adjust. point	Pattern
1	Connect sweep generator output to a three-turn loop antenna of 10mm diameter.	Sweep generator of 10.7 MHz center freq. with 10.7 MHz marker.	Tuning Knob fully counter-clockwise (Lowest Frequency.)	Set scope for connecting output signal from TP3 to vertical axis of scope "V" and sweep generator output to horizontal axis "H".	T001 (Violet Core) T102 (Black Core)	Turn the coil T102 fully counterclockwise to obtain a single peak. Adjust coil T001 in order until the best single peak is obtained. Figure 12. Finally turn the coil T102 to obtain S curve. See Figure 13.

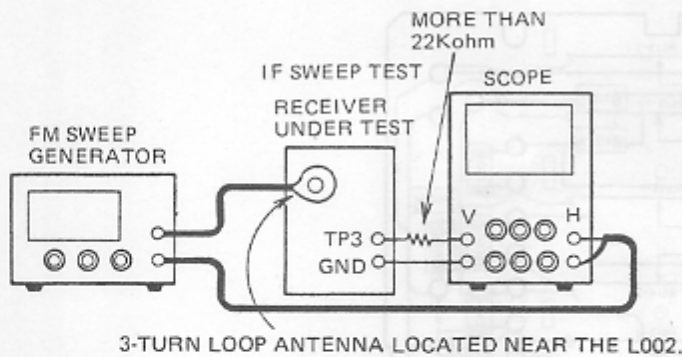

Figure 11

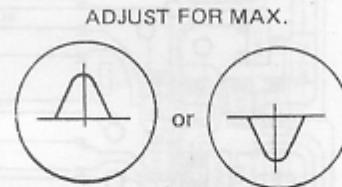

Figure 12

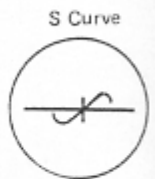

Figure 13

FM-RF ALIGNMENT

1. Turn on the signal generator and the VTVM, and allow a fifteen-minute warm-up period.
2. Connect the signal-generator output through a 75 ohm dummy antenna across FM antenna. (Figure 14)
3. Connect the VTVM across the Headphone Jack.
4. Set the volume control to mid-position.
5. Adjust the signal generator frequency as indicated in FM-RF ALIGNMENT CHART, and maintain a sufficient signal output level to provide a measurable indication.
6. Proceed as outlined in the FM-RF ALIGNMENT CHART.

FM-RF ALIGNMENT CHART

Step	Signal Generator	Radio Dial Setting	Adjustment	Remarks
1	87.3 MHz	Tuning Knob Fully Counter-clockwise (Lowest Frequency)	Osc. Coil L002	Adjust for maximum output indication.
2	108.5 MHz	Tuning Knob Fully Clockwise (Highest Frequency)	Osc. Trim. C012	Adjust for maximum output indication.
3	Repeat steps 1 and 2 as required.			
4	90 MHz	Tune to signal	Ant. Coil L001	Adjust for maximum output indication.
5	106 MHz		Ant. Trim. C010	
6	Repeat steps 4 and 5 as required.			

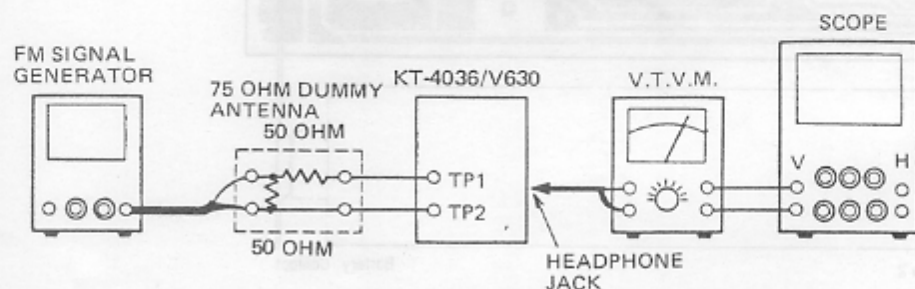

Figure 14

PLAYBACK HEAD ADJUSTMENT

Remove azimuth cover from front cabinet as shown in illustration.

A 6.3 kHz standard tape must be used for this adjustment. Connect a VTVM or an oscilloscope to the Headphone jack and adjust the azimuth by using a phillips screwdriver to maintain the maximum output voltage. (Figure 16)

Mount azimuth cover when the adjustment is completed.

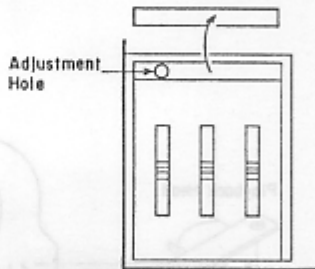

Figure 15

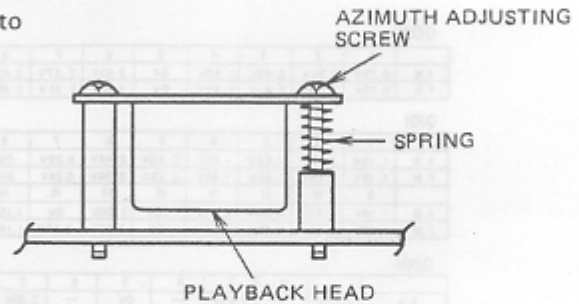

Figure 16

FREE RUN FREQUENCY ALIGNMENT

Adjust R204 under no signal condition so as to obtain $38 \text{ kHz} \pm 50 \text{ Hz}$.

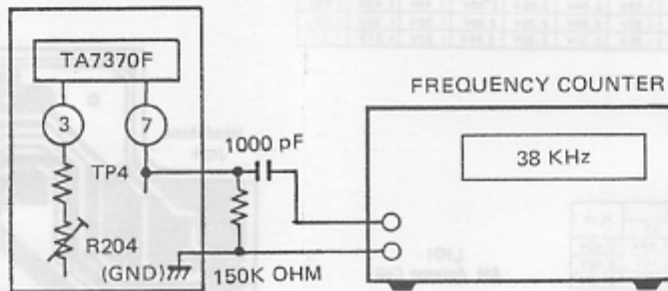

Figure 17

MOTOR SPEED ADJUSTMENT

1. Connect a Frequency counter to the headphone jack.
2. Insert cassette test tape (MTT-111 3 kHz).
3. Playback the test tape.
4. Adjust R907 for $3000 \text{ Hz} \pm 30 \text{ Hz}$ reading on the frequency counter by using a phillips screwdriver.

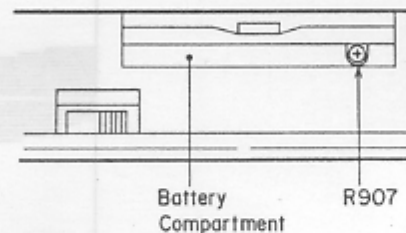

Figure 18

5. ELECTRICAL PARTS

Q001

	1	2	3	4	5	6	7	8
AM	0.75V	1.50V	2.43V	1.45V	0V	2.45V	2.37V	2.43V
FM	0.75V	1.50V	2.41V	1.45V	0V	2.40V	2.33V	2.40V

Q101

	1	2	3	4	5	6	7	8
AM	1.15V	1.15V	1.62V	1.62V	0.40V	0.44V	0.28V	0V
FM	1.18V	1.18V	1.60V	1.60V	0.33V	0.34V	0.24V	0V
	9	10	11	12	13	14	15	16
AM	1.14V	2.50V	2.50V	2.50V	1.15V	2.50V	0V	1.15V
FM	1.09V	2.50V	2.50V	2.50V	1.18V	2.50V	2.30V	1.18V

Q201

	1	2	3	4	5	6	7	8
AM	2.52V	—	2.49V	—	0V	—	2.05V	2.51V
FM (MONO)	2.52V	—	2.48V	—	0V	—	2.40V	2.51V
FM (ST)	2.53V	—	2.38V	—	0V	—	2.16V	2.08V
	9	10	11	12	13	14	15	16
AM	0.92V	—	0.91V	—	—	0.21V	—	2.02V
FM (MONO)	0.92V	—	0.91V	—	—	0.21V	—	2.03V
FM (ST)	0.92V	—	0.91V	—	—	0.21V	—	2.07V

Q301

	1	2	3	4	5	6	7	8
PLAY	1.46V	1.48V	1.49V	1.50V	0.10V	2.53V	1.52V	0V
RADIO	1.30V	1.30V	1.30V	1.30V	0.10V	2.55V	1.33V	0V
Motor Stop	1.31V	1.31V	1.31V	1.31V	0.10V	2.49V	1.39V	0V
	9	10	11	12	13	14	15	16
PLAY	2.95V	1.54V	2.54V	2.28V	2.95V	1.49V	1.49V	1.49V
RADIO	2.99V	1.55V	2.58V	2.28V	2.99V	1.30V	1.30V	1.28V
Motor Stop	2.92V	1.56V	2.51V	2.22V	2.92V	1.30V	1.31V	1.31V

Q202,203

	RADIO	PLAY
E	0V	0V
C	0V	0V
B	0.60V	0V

Q204

	AM	MONO	ST	PLAY
E	2.58V	2.58V	2.58V	0.42V
C	2.57V	2.57V	2.10V	0.42V
B	0V	0V	2.58V	0.45V

Q302

	RADIO	PLAY
E	2.99V	2.95V
C	2.58V	2.54V
B	2.28V	2.28V

Q402

	RADIO	PLAY
E	0V	0V
C	0.05V	1.40V
B	0.67V	0V

L101
AM Antenna Coil

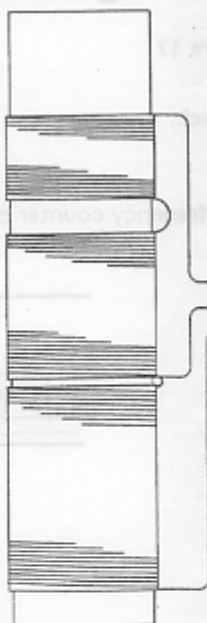

Q401

	1	2	3	4	5	6	7	8
FWD (NR)	1.26V	1.30V	2.48V	1.30V	0V	1.25V	1.30V	0.02V
METAL	1.27V	1.30V	2.45V	1.30V	0V	1.27V	1.30V	0.02V
REV	1.29V	1.24V	2.48V	1.30V	0V	1.29V	1.24V	0.60V
	9	10	11	12	13	14	15	16
FWD (NR)	0.65V	0.06V	1.24V	1.29V	1.36V	1.30V	1.33V	1.29V
METAL	0.65V	0.06V	1.28V	1.25V	1.36V	1.30V	1.33V	1.25V
REV	0V	1.20V	0.05V	1.29V	1.39V	1.30V	1.36V	1.29V

Q901

	1	2	3	4	5	6	7	8
PLAY	—	—	2.52V	1.47V	0V	2.58V	—	2.38V
FF	—	—	2.93V	1.49V	0V	2.60V	—	2.40V

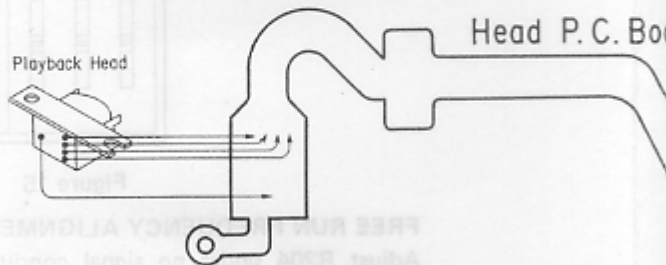

Main P.C. Board

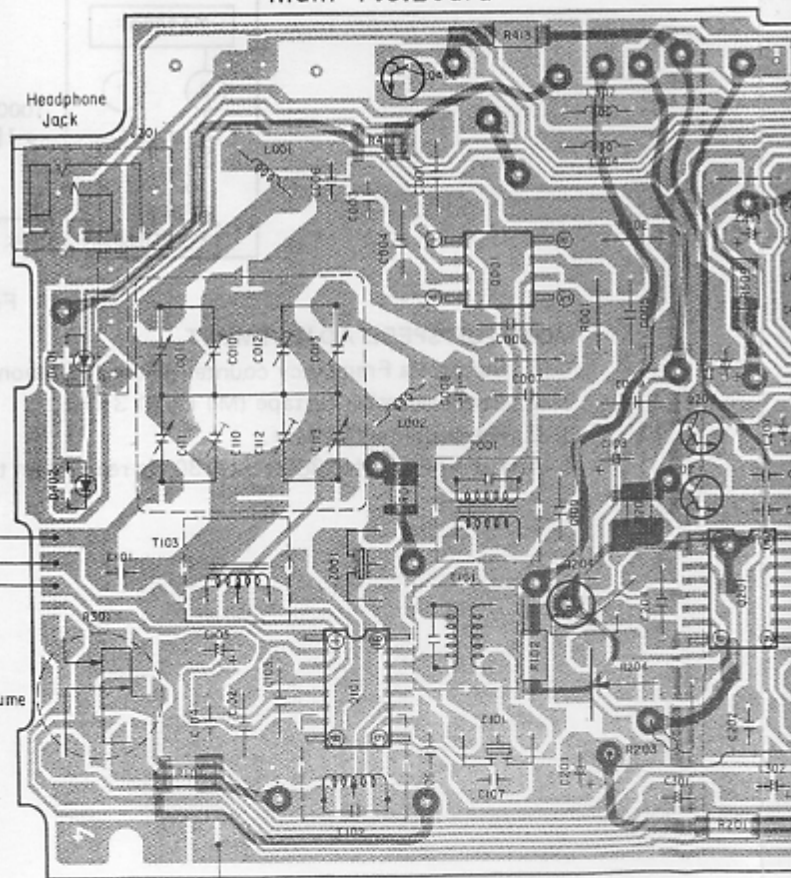

Battery Spring

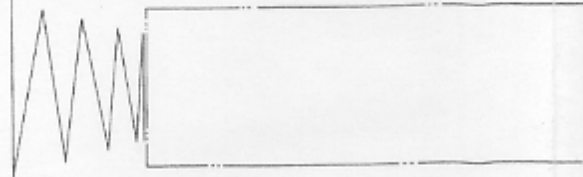

S LOCATIONS

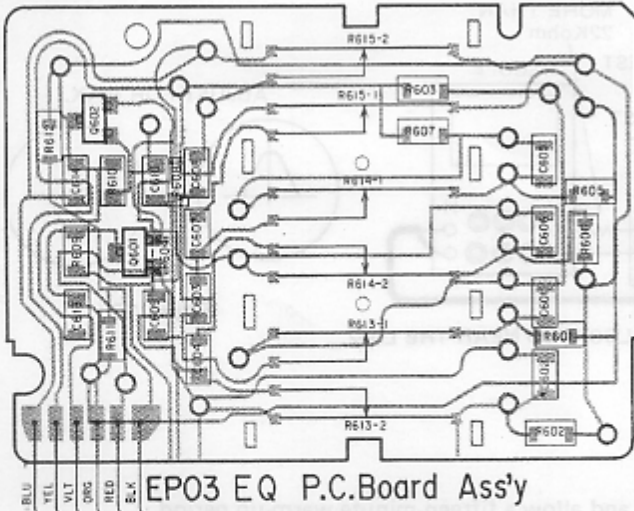

Board

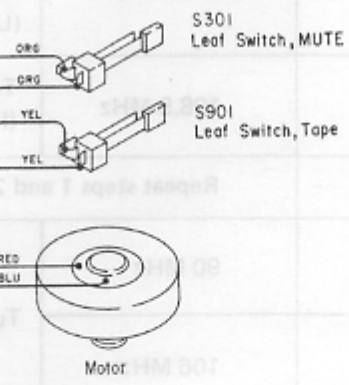
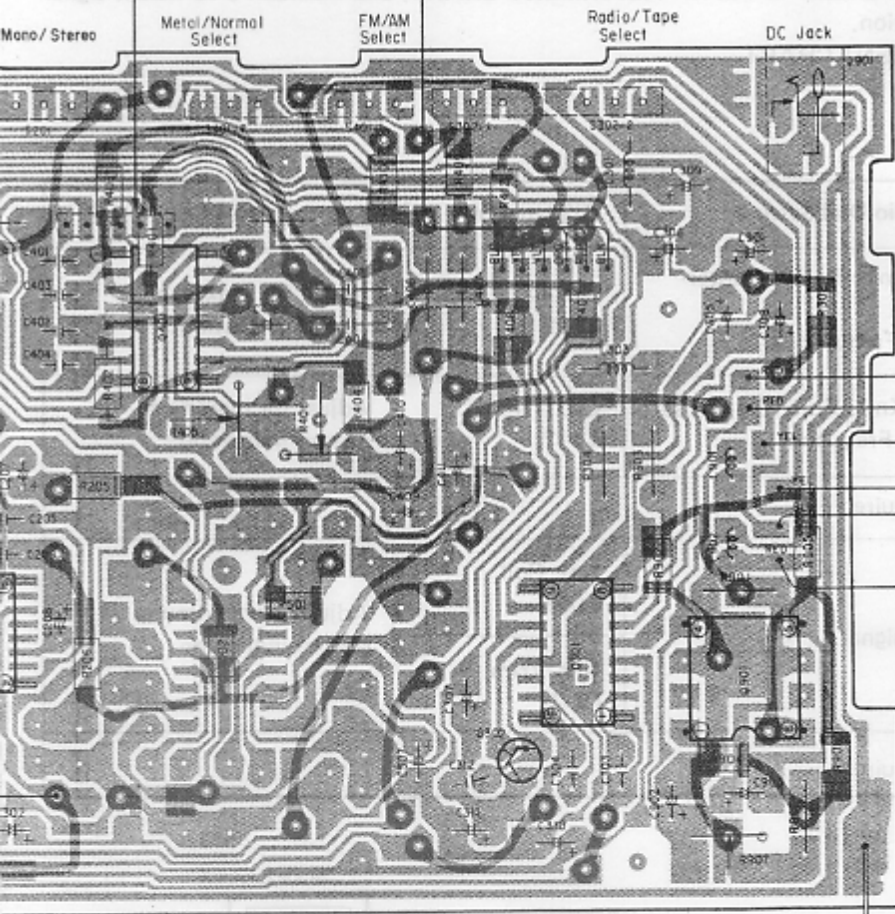

Battery 1.5x2

Battery Contact

6. SCHEM

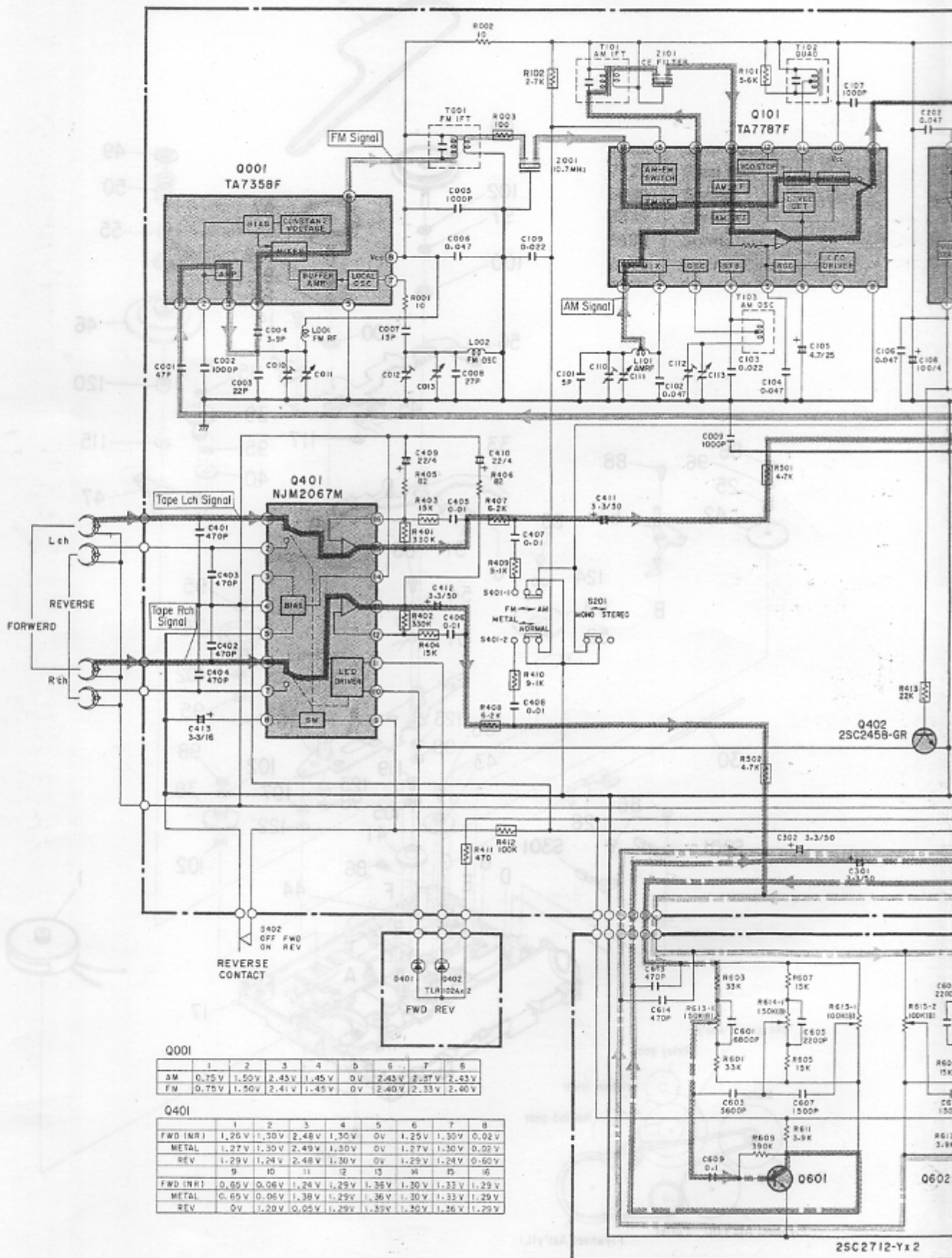

MATIC DIAGRAM

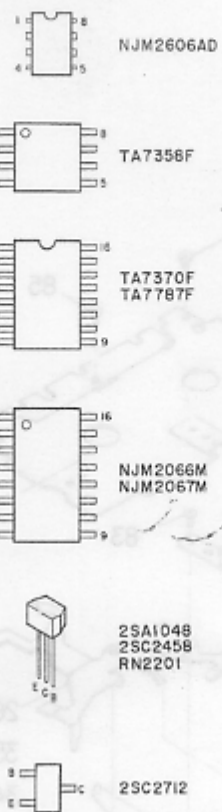
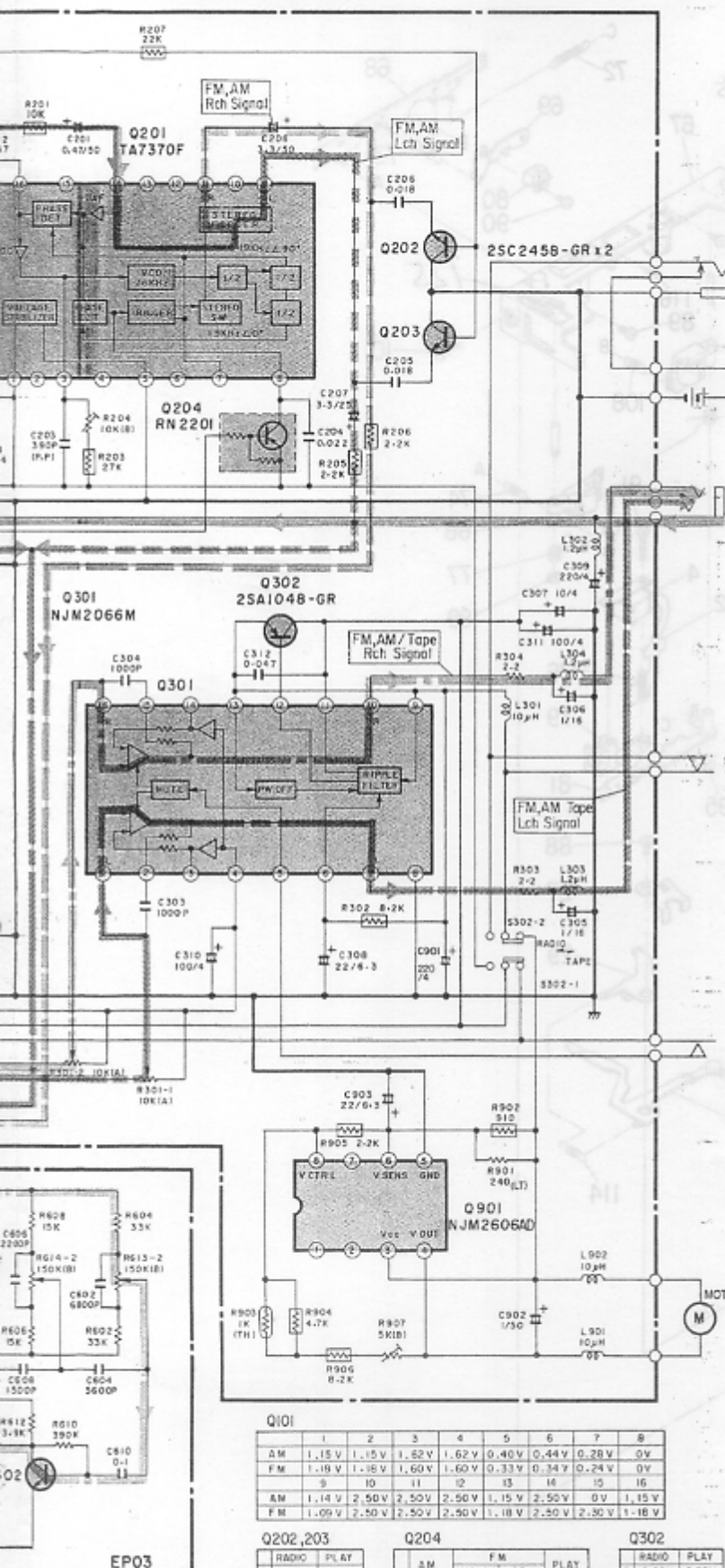

- Switch Position
- S201 Mono/Stereo Switch
 - S301 MUTE Leaf Switch
 - S302 Radio/Tape Select Switch
 - S401-1 FM/AM Select Switch
 - S401-2 Metal/Normal Select Switch
 - S901 Tape Leaf Switch
- MONO-
OFF
Tape
AM
Normal
OFF

Q201

	1	2	3	4	5	6	7	8
AM	2.52V	—	2.49V	—	0V	—	2.05V	2.51V
FM (MONO)	2.52V	—	2.49V	—	0V	—	2.40V	2.51V
FM (ST)	2.53V	—	2.38V	—	0V	—	2.16V	2.08V
AM	0.90V	—	0.91V	—	—	0.21V	—	2.02V
FM (MONO)	0.92V	—	0.91V	—	—	0.21V	—	2.03V
FM (ST)	0.92V	—	0.91V	—	—	0.21V	—	2.07V

Q301

	1	2	3	4	5	6	7	8
PLAY	1.48V	1.48V	1.49V	1.50V	0.10V	2.53V	1.52V	0V
RADIO	1.30V	1.30V	1.30V	1.30V	0.10V	2.55V	1.33V	0V
Motor Stop	1.31V	1.31V	1.31V	1.31V	0.10V	2.49V	1.39V	0V
PLAY	2.95V	1.94V	2.64V	2.28V	2.95V	1.49V	1.49V	1.49V
RADIO	2.99V	1.35V	2.58V	2.28V	2.99V	1.30V	1.30V	1.28V
Motor Stop	2.92V	1.36V	2.51V	2.22V	2.92V	1.30V	1.31V	1.31V

Q901

	1	2	3	4	5	6	7	8
PLAY	—	—	2.92V	1.47V	0V	2.58V	—	2.38V
FF	—	—	2.93V	1.49V	0V	2.60V	—	2.40V

Q101

	1	2	3	4	5	6	7	8
AM	1.15V	1.15V	1.62V	1.62V	0.40V	0.44V	0.28V	0V
FM	1.18V	1.18V	1.60V	1.60V	0.33V	0.34V	0.24V	0V
AM	1.14V	2.50V	2.50V	2.50V	1.15V	2.50V	0V	1.15V
FM	1.09V	2.50V	2.50V	2.50V	1.18V	2.50V	2.30V	1.18V

Q202, 203

RADIO	PLAY
E	0V
C	0V
B	0.60V

Q204

	AM	MONO	ST	PLAY
E	2.58V	2.58V	2.58V	0.42V
C	2.57V	2.57V	2.10V	0.42V
B	0V	0V	2.58V	0.45V

Q302

RADIO	PLAY
E	2.99V
C	2.98V
B	2.28V

Q402

RADIO	PLAY
E	0V
C	0.05V
B	0.67V

7-1. MECHANISM EXPLODED VIEW (UPPER)

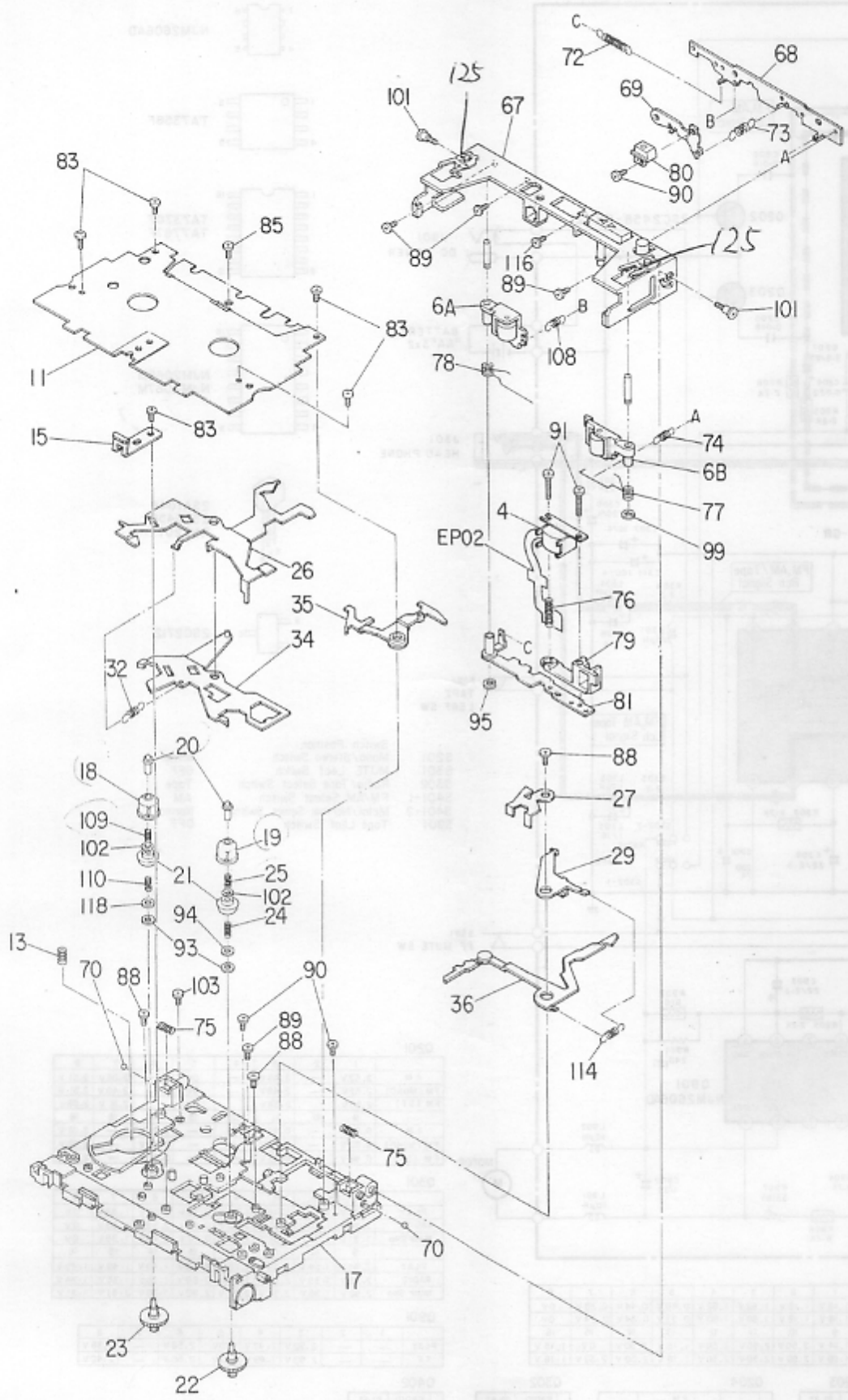

NOTE: Parts excluded in the parts list are not stocked since they are seldom required for routine service. Some delay should be anticipated when ordering these items.

7-2. MECHANISM EXPLODED VIEW (LOWER)

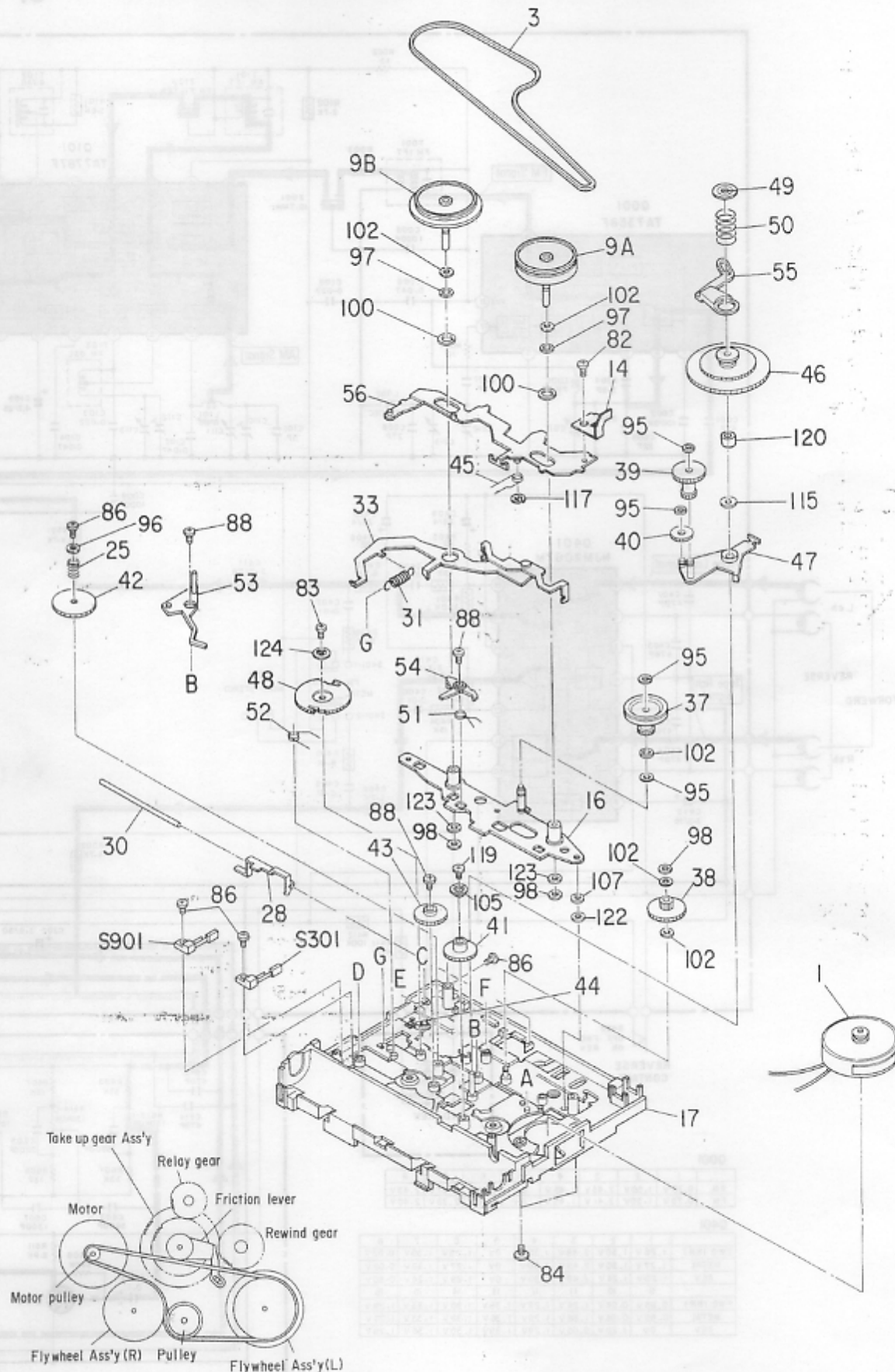

NOTE: Parts excluded in the parts list are not stocked since they are seldom required for routine service. Some delay should be anticipated when ordering these items.

Description	Part No.	Location No.
470 ohm (PRC)	32884471	R411
100K ohm (PRC)	32884104	R412
32K ohm (PRC)	32884028	R413
4.7K ohm (PRC)	32884472	R501, 802
240 ohm, Linear	32880473	R801
970 ohm (PRC)	32884087	R802
1K ohm, Thermistor	32118188	R803
4.7K ohm (PRC)	32884472	R804
2.2K ohm (PRC)	32884232	R805
8.2K ohm (PRC)	32884822	R806
8K ohm, B, Semi-fixed	32888728	R807
Variable		
ACCESSORIES		
Owner's Manual (U.S.A.)	32808028	AC01
Owner's Manual (Canada)	32808027	AC01
Owner's Manual (Others)	32808028	AC01
Caution Sheet (U.S.A.)	32887028	AC02
Unit Holder	38832882	AC03
Headphone, HP-M31-A	32182707	AC04
Ear Pad Set	32810128	AC05

Description	Part No.	Location No.
EL, 3.3mfd, 50V, M	32440442	C301, 302
CD, 1000pf, 50V, K	32348102	C303, 304
TT, 1mfd, 18V	32480088	C305, 308
TT, 10mfd, 4V, M	32440441	C307
EL, 22mfd, 6.3V, M	32440451	C308
EL, 22mfd, 4V, M	32440827	C309
EL, 100mfd, 4V, M	32440817	C310, 311
BL, 0.047mfd, 18V, Z	32380881	C312
CD, 470pf, 50V, K	32380382	C401, 402
BL, 0.01mfd, 18V, M	32380870	C403, 404
EL, 22mfd, 4V, M	32440880	C405, 408
EL, 22mfd, 4V, M	32440840	C410
EL, 2.2mfd, 80V, M	32440887	C411, 412
EL, 2.2mfd, 18V, M	32440828	C413
EL, 220mfd, 4V, M	32440818	C501
EL, 1mfd, 50V, M	32440441	C502
EL, 22mfd, 6.3V, M	32440451	C503
RESISTORS		
All resistors are carbon film 1/8W, 5% unless otherwise noted.		
1M ohm = 1000K ohm, PRC = Printed Resistor Circuit		
R001, 002	32884100	10 ohm
R003	32884101	100 ohm (PRC)
R101	32884802	5.6K ohm (PRC)
R102	32884272	2.7K ohm (PRC)
R301	32884103	10K ohm (PRC)
R502	32884273	27K ohm
R504	32887021	10K ohm, Semi-fixed
		Variable
R202, 308	32884232	2.2K ohm (PRC)
R307	32884233	32K ohm (PRC)
R307, 1, 2	32811418	10K ohm, Variable
R302	32884022	8.2K ohm (PRC)
R303, 304	32884220	2.2 ohm
R401, 402	32844234	320K ohm (PRC)
R403, 404	32884183	15K ohm (PRC)
R405, 408	32884820	82 ohm
R407, 408	32840893	8.2K ohm (PRC)
R409, 410	32840787	8.2K ohm (PRC)

TOSHIBA CORPORATION
1-1, SHIBAURA 1-CHOME, MINATO-KU, TOKYO 105, JAPAN