

TOSHIBA

FILE NO. 400-200603GR

SERVICE MANUAL

 gigabeat S Series

DIGITAL AUDIO PLAYER

MES60V, MES30V *(US/CA)*



The above models are classified as green products (*1).
This Service Manual describes replacement parts for the green products. When repairing these green product(s), use the part(s) described in this manual and lead-free solder (*2).

For (*1) and (*2), see the next page.

DOCUMENT CREATED IN JAPAN, JUNE, 2006

(*1)

GREEN PRODUCT PROCUREMENT

The EC is actively promoting the WEEE & RoHS Directives that define standards for recycling and reuse of Waste Electrical and Electronic Equipment and for the Restriction of the use of certain Hazardous Substances. From July 1, 2006, the RoHS Directive will prohibit any marketing of new products containing lead.

Increasing attention is given to issues related to the global environmental. Toshiba Corporation recognizes environmental protection as a key management tasks, and is doing its utmost to enhance and improve the quality and scope of its environmental activities. In line with this, Toshiba proactively promotes Green Procurement, and seeks to purchase and use products, parts and materials that have low environmental impacts.

Green procurement of parts is not only confined to manufacture. The same green parts used in manufacture must also be used as replacement parts.

(*2)

LEAD-FREE SOLDER

This product is manufactured using lead-free solder as a part of a movement within the CE industry at large to be environmentally responsible. Lead-free solder must be used in the servicing and repair of this product.

WARNING

This product is manufactured using lead free solder.

DO NOT USE LEAD BASED SOLDER TO REPAIR THIS PRODUCT !

The melting temperature of lead-free solder is higher than that of leaded solder by 86°F to 104°F (30°C to 40°C). Use of a soldering iron designed for lead-based solders to repair product made with lead-free solder may result in damage to the component and or PCB being soldered. Great care should be made to ensure high-quality soldering when servicing this product –especially when soldering large components, through-hole pins, and on PCBs – as the level of heat required to melt lead-free solder is high.

IN-WARRANTY SERVICE

In-Warranty service for the MES60V and MES30V Digital Audio Player is fulfilled via product exchange.



Contact Toshiba Customer Solutions for instructions. 1-866-583-7353.

Precautions

Safety Precautions for Service

This section provides critical information for safety. Be sure to observe the content.

Meaning of each indication is as follows:









 DANGER	Safety indications mean that death or serious injury may be caused to service personnel and/or surrounding people or users due to incorrect work by neglecting safety instructions or due to resulting defects of the product, which indicates imminence of danger.
 WARNING	Death or serious injury may be caused to service personnel and/or surrounding people or users due to incorrect work by neglecting the following instructions or due to resulting defects of the product.
 CAUTION	Injury or physical damage* may be caused to service personnel and/or surrounding people or users due to incorrect work by neglecting the following instructions or due to resulting defects of the product.

* Physical damage includes damage to buildings, household goods, properties, livestock, and pets.

WARNING

<ul style="list-style-type: none"> • Unplug the power cable before starting work (for example, disassembly) that does not need power supply. Otherwise, it may cause electric shock.
<ul style="list-style-type: none"> • Use an insulation transformer and/or wear protective gloves when power is ON, and unplug the power cable when replacing parts to avoid electric shock.
<ul style="list-style-type: none"> • Use specified spare parts of the product for replacement. Since some parts have safety characteristics (fire resistance, withstand voltage, etc.), use replacement parts with same characteristics. For safety-sensitive parts specified by marking in circuit diagrams or parts lists, use specified parts.
<ul style="list-style-type: none"> • After repair work is completed, properly reassemble disassembled parts and securely reconnect cables as they were. For safety reasons, some insulating materials such as tubes and tapes are used, and some parts are mounted with a gap from the board surface. Furthermore, internal wiring is kept away from heating parts or high-voltage parts by using clampers or by other means. When reassembling/reconnecting these parts, put them as they were. Do not catch the internal cables by the cabinet or cover. Improper assembling or cable connection may cause electric leak or fire, which may lead to an accident on the user side.
<ul style="list-style-type: none"> • After repair work is completed, unplug the power cable, and measure the insulation resistance between the external metal portion and plug blade with a 500V megger. The resistance shall be 1M ohms or more. If the resistance is lower than 1M ohms, inspect and rectify the product.
<ul style="list-style-type: none"> • Do not alter the product. Alteration of the product may cause malfunction or failures, which may lead to an accident such as electric leak or fire on the user side.
<ul style="list-style-type: none"> • Advise users to keep children away from the on-site work area. Children in the work area may be injured by tools, disassembled product or parts.

Precautions for Removing the Built-in Battery

 DANGER	Do not attempt to drive a nail into the built-in battery, nor strike it with a hammer, step on it or otherwise subject it to strong impact. The electrodes may shortcircuit, resulting in heat generation, explosion or ignition.
 DANGER	Do not connect the electrodes (positive/negative terminals) of the built-in battery using a wire or other metal object. Also avoid carrying or storing the battery together with a necklace, hairpin or other object made of metal. The electrodes may short-circuit, resulting in heat generation, explosion or ignition.
 DANGER	Do not heat, disassemble or modify the built-in battery or place it in fire or water. Doing so may cause an explosion, ignition or heat generation, resulting in fire or serious injury.
 DANGER	Do not place the built-in battery near fire or in the heat of the sun. Doing so may result in fire, explosion or heat generation.
 DANGER	Do not bring the built-in battery near heating equipment. Doing so may result in fire, explosion or heat generation.
 DANGER	Wrap the connector of the built-in battery with insulation tape. Otherwise, the electrodes may short-circuit, resulting in heat generation, explosion or ignition.
 WARNING	Do not place the built-in battery within the reach of small children. Doing so may result in injury or accident.
 WARNING	If leaked fluid from the built-in battery should enter your eye, rinse with clean water and seek immediate medical attention. Neglecting proper cleaning or medical treatment may result in eye injury.

CONTENTS

1. PRODUCT OVERVIEW	2
1.1. PRODUCT OUTLINE	2
1.1.1. INTERNAL COMPOSITION	2
1.1.2. ACCESSORIES	3
1.1.3. PLACE FOR STORING THE FIRMWARE	3
1.1.4. ABOUT CONTENT PROTECTION	3
1.1.5. HOW MUSIC/VIDEO IS PLAYED BACK	4
1.1.6. TRANSFER OF CONTENT FROM THE PC	4
2. BLOCK DIAGRAM	5
2.1. LOGIC CIRCUIT BLOCK DIAGRAM	5
2.2. POWER CIRCUIT BLOCK DIAGRAM	6
3. CAUTIONS ON REPAIR	7
3.1. TELL THE OWNER THAT THE CONTENTS ON THE HDD MAY BE ERASED	7
3.2. REMOVE THE AC ADAPTOR AND SET THE BATTERY SWITCH TO OFF	7
3.3. WHEN REPLACING THE HDD	8
3.3.1. PROTECT THE HDD FROM IMPACT	8
3.3.2. HOLDING THE HDD	8
3.3.3. PROCESS AT HDD REPLACEMENT	9
3.4. WHEN REPLACING THE MAIN BOARD	12
3.4.1. UPDATING THE FIRMWARE	12
3.5. WHEN REPLACING THE LCD AND LCD BACKLIGHT UNIT	16
3.5.1. INCORPORATING THEM INTO THE LCD FRAME	16
4. TROUBLESHOOTING	17
4.1. ANTICIPATED DEFECTS	17
4.2. DEFECT ANALYSIS PROCEDURE AS A MAINTENANCE SERVICE	18
4.2.1. THE UNIT WILL NOT TURN ON	18
4.2.2. NO SOUND COMES OUT	20
4.2.3. FM CANNOT BE RECEIVED	20
4.2.4. THE SOUND IS ODD	21
4.2.5. THE LCD DISPLAY IS ODD	21
4.2.6. THE BUTTONS OF UNIT DO NOT WORK	21
4.2.7. THE REMOTE CONTROLLER DOES NOT WORK	21
4.2.8. THE USB CONNECTION FAILS	21
4.2.9. THE BATTERY CANNOT BE RECHARGED	
(WHEN BATTERY-POWERED, THE UNIT PLAYS BACK ONLY FOR A SHORT TIME.)	22
4.2.10. HDD IS NOT RECOGNIZED	23
5. PROCEDURE TO CONFIRM THE UNIT'S F/W VERSION	24
6. DISASSEMBLING/REASSEMBLING PROCEDURES	25
6.1. DISASSEMBLING PROCEDURES	25
6.2. REASSEMBLING PROCEDURES	30
7. EXPLODED VIEW	34
8. PARTS LIST	35

1. Product Overview

[TOSHIBA HDD audio player gigabeat S series] is the portable audio player in which the HDD of 30GB/60GB is built. As the built-in HDD is thick, the MES60 is thicker.

Main differences from the previous model (gigabeat X series) are as follows.

- By adopting the push-type button, the operability is enhanced.
- PMC (Portable Media Center) is adopted.

1.1. Product Outline

1.1.1. Internal Composition

The gigabeat S series consists of the following main components.

- Main board

A part of firmware is stored in the flash ROM on the main board.

- HDD

The HDD is partitioned into two partitions. One is for data and the other is for system.

The firmware is stored in the system partition.

Contents such as music data are stored in the data partition.

Data other than music data such as Word files can be stored in the external HDD.

(But, files cannot be directly opened.)

- TFT color liquid crystal display
- White LED backlight
- Battery
- Switches

13 pieces PMC compliant push button (7 pieces on the front, 6 pieces at sides)

- Cabinet parts

The HDD is covered with special rubber and held in the air. This keeps it resistant to impact and vibration.

1.1.2. Accessories

The product is furnished with main accessories as follows.

- AC adaptor
- Power cord (which varies with destinations.)
- USB cable
- USB conversion cable
- Wired remote controller (Option)
- Headphones
- Software CD-ROM
- Owner's Manual

1.1.3. Place for storing the firmware

The firmware is stored in the flash ROM on the main board and on the HDD. The firmware is stored in the system partition on the HDD. Even if a PC is connected, the system partition cannot be seen on the Explorer.

1.1.4. About Content Protection

Using the Windows Media DRM10, the contents are protected.

Using the Windows standard application Windows Media Player 10, transfer (copy) the music data (WMA/MP3/WAV format)/video data (WMV) stored in a PC to the HDD so that the transferred content can be played back. Transferring the data via USB is also possible.

When the content, which is once transferred to a PC by the Explorer, is transferred to other gigabeat S series, unless the content is protected by the Windows Media DRM, the content can be played back. But, when the content protected by the Windows Media DRM is transferred to other gigabeat S series, unless the license of the content to be transferred is acquired, the content cannot be played back.

1.1.5. How music/video is played back

This section explains how the unit plays back the content (compressed music data (WMA/MP3, PCM music data (WAV) and video data (WMV)) stored on the HDD.

The CPU reads out the content data (WMA/MP3/WAV/WMV) on the HDD and stores it in the SDRAM.

The CPU accesses to the HDD every few minutes (It differs depending on the content's bit rate.), reads out the data, and accumulates it in the SDRAM. When the HDD is not accessed, the power of HDD is turned off to save the power. However, as the PCM music data contains the large amount, the HDD is always powered.

The CPU restores the compressed music data in the SDRAM and converts it to PCM data.

If the data in the SDRAM is video, the CPU restores it to bit map data. The music data restored to the PCM is sent from the SDRAM to the DAC by the CPU. In case of video data, the CPU sends the bit map data to the LCD.)

The DAC converts the PCM music data to the analog signal, which is then outputted to headphones. The CPU sets the volume control and equalizer levels in the DAC, which controls the volume level and equalizer levels, using their set data.

1.1.6. Transfer of content from the PC

When the unit is connected to the PC with the USB cable, the PC recognizes the unit as a MTP device (MultiMedia Transfer Protocol device).

When transferring the content by using the Windows Media Player on the PC, the content data is sent to the unit via USB. Then, according to the MTP protocol, the CPU writes the received content data on the HDD.

2. Block diagram

2.1. Logic circuit block diagram

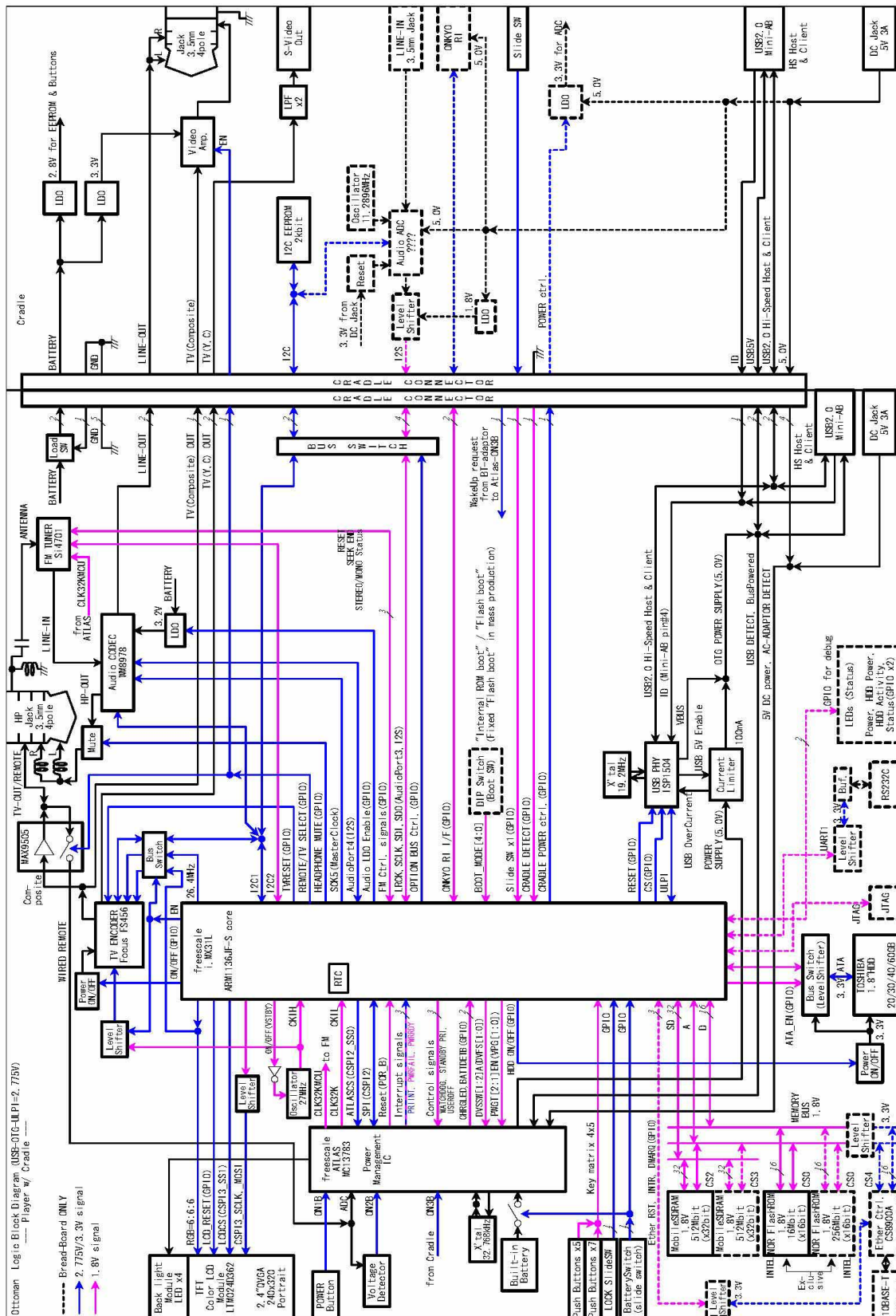

2.2. Power circuit block diagram

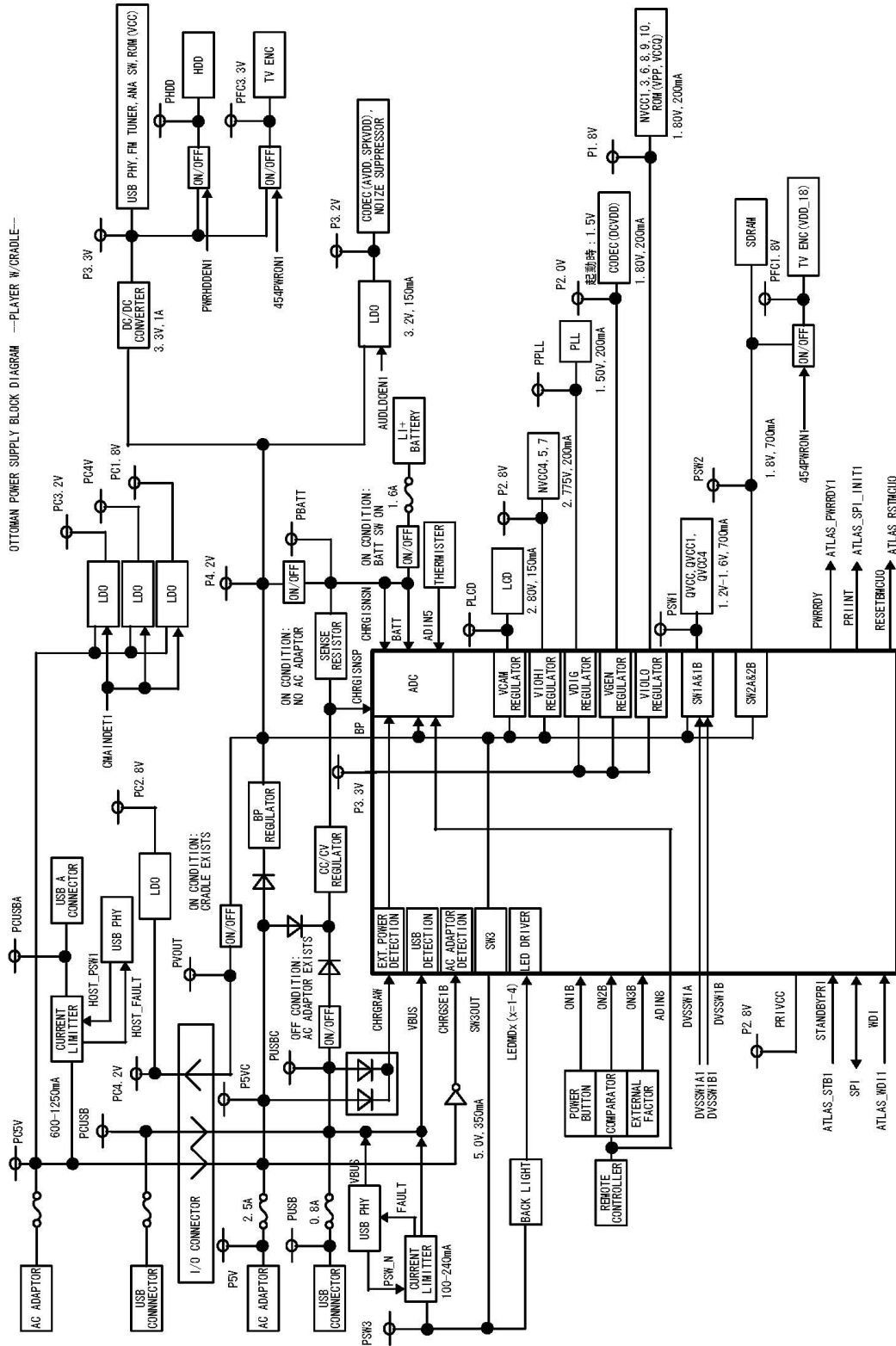

3. Cautions on repair

Before repairing a product of the gigabeat S series, take the following cautions:

3.1. Tell the owner that the contents on the HDD may be erased.

Replacing or formatting the HDD will erase the content on the HDD.

Therefore, in receiving the product from the owner, ask the owner to back up his/her important data.

3.2. Remove the AC adaptor and set the BATTERY switch to OFF.

Before disassembling, ensure to remove the AC adaptor and set the BATTERY switch to “OFF”.

When the gigabeat S series is powered by the AC adaptor or the battery, even if the power switch is turned off, the power is supplied to the LCD and almost all ICs. Therefore, before repairing, the AC adaptor or the battery must be removed.

By setting the BATTERY switch to “OFF”, the power supply from the battery is stopped and the unit becomes in the same state as when the battery is removed.

3.3. When replacing the HDD

3.3.1. Protect the HDD from impact.

Note that the HDD is vulnerable to impact. Merely falling the HDD from a vertical position would give an impact exceeding the specifications.

3.3.2. Holding the HDD

When holding the HDD, hold it at the following position:

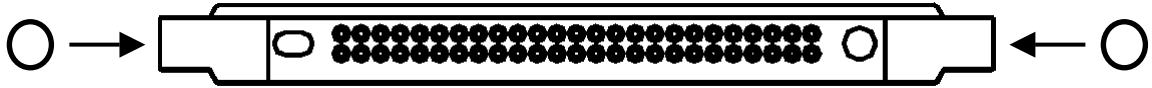

Do not hold it at the following position:

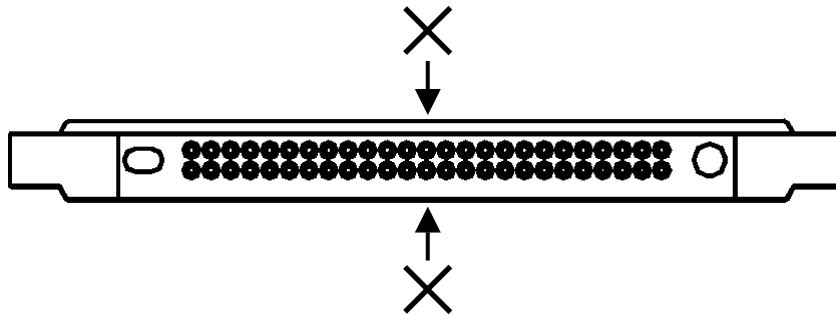

3.3.3. Process at HDD replacement

When replaced to the un-formatted HDD, restore the HDD in the factory setting state by transferring the firmware and the supplied data to the HDD in the procedure below.

[HDD formatting]

- 1) Set the BATTERY switch to “OFF”.
- 2) Connect the AC adaptor and start up the unit.
- 3) Format automatically the HDD and display the menu below on the LCD. Wait until the menu appears.



Fig. Menu of waiting for the PC connection

[T&D Transfer]

- 4) Start up [Transfer Program (Ottoman.exe) on the PC and select the scenario file (*.ini) in which files to be transferred are described. Ottoman.exe and the scenario file are provided on the CD-ROM (Material No.: 360058245). Names for the destination-wise stored folder and file are different depending on the destination. The relationship between destination and folder is shown on the table below.

Table Destination and Folder

Destination	Folder name	Scenario file name
Japan	OTTOMAN_T&D_FW_JP	OTTOMAN_T&D_FW_JP.ini
U.S.A.	OTTOMAN_T&D_FW_US	OTTOMAN_T&D_FW_US.ini

Start up Ottoman.exe and select the scenario file. Then, the menu below appears.

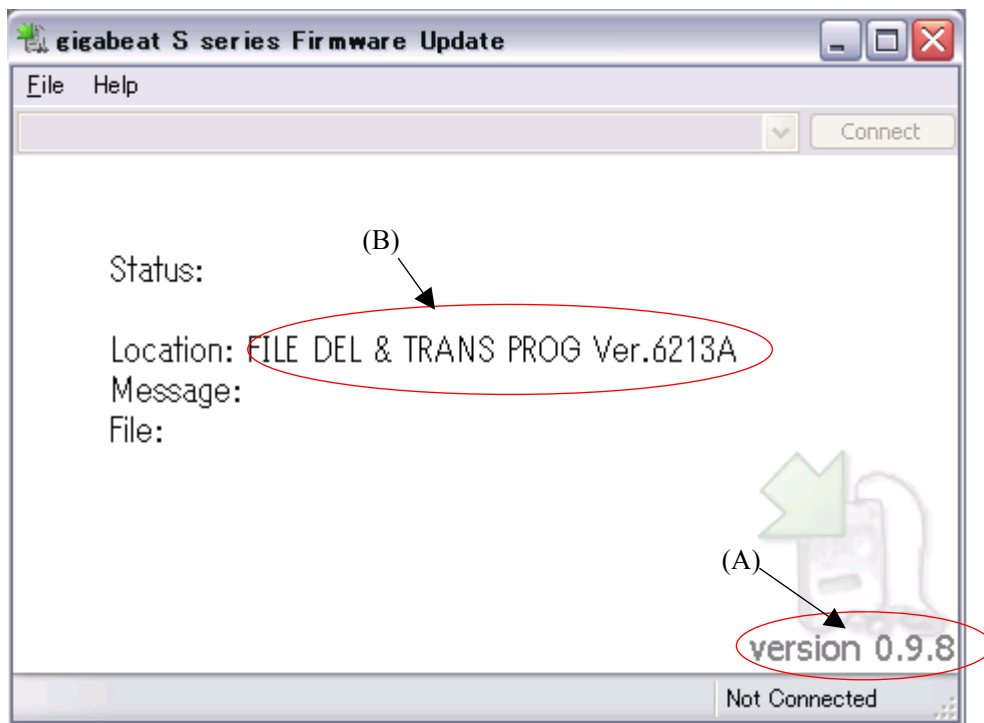

Fig. Menu display on the PC (T&D Transfer)

Check two points of (A) and (B) on the above menu. These are different for every destination ((A) is same.) The display for every destination is as shown below.

Table Difference on the display by destination (Differences are underlined.)

Destination	(A)	(B)
Japan	version 0.9.9.10	T&D TRANS PROG(<u>JP</u>) Ver.6423A
U.S.A.	version 0.9.9.10	T&D TRANS PROG(<u>US</u>) Ver.6423A

- 5) Wait for a while. Then, “OK” appears on the PC.
- 6) Remove the USB cable. At this moment, be careful not to touch the POWER button. By removing the USB cable, “OK” on the PC disappears.
- 7) The unit is automatically started up.

[Transfer of FW for factory setting]

- 8) Transfer the FW for factory setting in the same manner as in step 4). Terminate Ottoman.exe once. And start up newly the [Transfer Program (Ottoman.exe)] on the PC and select the scenario file (*.ini) in which files to be transferred are described.
Ottoman.exe and the scenario file are provided on the CD-ROM (Material No.: 360058245).
Names for the destination-wise stored folder and file are different depending on the destination.
The relationship between destination and folder is shown on the table below.

Table Destination and Folder

Destination	Folder name	Scenario file name
Japan	OTTOMAN_DEL_JP	OTTOMAN_DEL_JP.ini
U.S.A.	OTTOMAN_DEL_US	OTTOMAN_DEL_US.ini

The menu display is the same as in step 4). Check two points of (A) and (B) on the menu in step 4). These are different for every destination ((A) is same.) The display for every destination is shown below.

Table Differences of display by destination (Differences are underlined.)

Destination	(A)	(B)
Japan	version 0.9.9.10	FILE DEL & TRANS PROG(<u>JP</u>) Ver.6423A
U.S.A.	version 0.9.9.10	FILE DEL & TRANS PROG(<u>US</u>) Ver.6423A

- 9) Wait for a while. Then, “OK” appears on the PC.
- 10) Remove the USB cable. At this moment, be careful not to touch the POWER button. By removing the USB cable, “OK” on the PC disappears.
- 11) The unit is automatically started up.

[Transfer of supplied data for factory setting]

- 12) Transfer the supplied data for factory setting in the same manner as in step 4). Terminate Ottoman.exe once. Then, start up newly the [Transfer Program (Ottoman.exe)] on the PC and select the scenario file (*.ini) in which files to be transferred are described.
Ottoman.exe and the scenario file are provided on the CD-ROM (Material No.: 360058245). Names for the destination-wise stored folder and file are different depending on the destination. The relationship between destination and folder is shown on the table below.

Table Destination and Folder

Destination	Folder name	Scenario file name
Japan	OTTOMAN_SAMPLE_JP	OTTOMAN_SAMPLE_JP.ini
U.S.A.	OTTOMAN_SAMPLE_US	OTTOMAN_SAMPLE_US.ini

The menu display is the same as in step 4). Check two points of (A) and (B) on the menu in step 4). These are different for every destination ((A) is same.) The display for every destination is shown below.

Table Differences of display by destination (Differences are underlined.)

Destination	(A)	(B)
Japan	version 0.9.9.10	TRANS SAMPLE COMTENTS(<u>JP</u>) Ver.6423A
U.S.A.	version 0.9.9.10	TRANS SAMPLE COMTENTS (<u>US</u>) Ver.6423A

- 13) Wait for a while. Then, “OK” appears on the PC.
- 14) Remove the USB cable. At this moment, be careful not to touch the POWER button.
By removing the USB cable, “OK” on the PC disappears.
- 15) Hold down the Power key to suspend (Power OFF).
- 16) Plug out the AC adaptor.

3.4. When replacing the main board

3.4.1. Updating the firmware.

After replacing the main board, update the firmware in the procedure below.

As explained in “1.1.3 Location to store the firmware”, the firmware is stored in both the flash ROM on the main board and on the HDD. Unless the versions of firmware at two locations are matched, the malfunction will occur. Therefore, whenever the main board is replaced, update the firmware in the procedure below to match the versions at two locations.

For the procedure when replacing the HDD, see “3.3 When replacing the HDD”.

[HDD formatting]

- 1) Set the BATTERY switch to “OFF”.
- 2) Connect the AC adaptor and start up the unit.
- 3) Format automatically the HDD and display the menu below on the LCD. Wait until the menu appears.



Fig. Menu of waiting for the PC connection

[T&D Transfer]

- 4) Start up the [Transfer Program (Ottoman.exe)] on the PC and select the scenario file (*.ini) in which files to be transferred are described.

Ottoman.exe and the scenario file are provided on the CD-ROM (Material No.: 360058245). Names for the destination-wise stored folder and file are different depending on the destination. The relationship between destination and folder is shown on the table below.

Table Destination and Folder

Destination	Folder name	Scenario file name
Japan	OTTOMAN_T&D_FW_JP	OTTOMAN_T&D_FW_JP.ini
U.S.A.	OTTOMAN_T&D_FW_US	OTTOMAN_T&D_FW_US.ini

Start up the Ottoman.exe and select the scenario file. Then, the menu below appears.

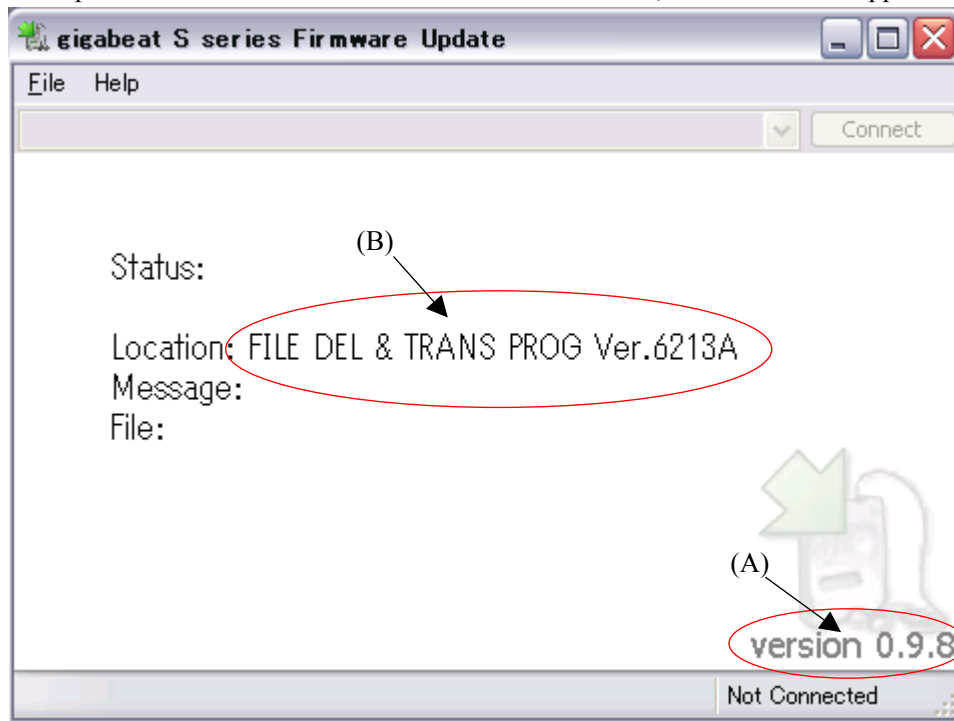

Fig. Menu display on the PC (T&D Transfer)

Check two points of (A) and (B) on the above menu. These are different depending on the destination ((A) is same.) The display for every destination is as follows.

Table Differences of display by destination (Differences are underlined.)

Destination	(A)	(B)
Japan	version 0.9.9.10	T&D TRANS PROG(<u>JP</u>) Ver.6423A
U.S.A.	version 0.9.9.10	T&D TRANS PROG(<u>US</u>) Ver.6423A

- 5) Wait for a while. Then, “OK” appears on the PC.
- 6) Remove the USB cable. At this moment, be careful not to touch the POWER button.
By removing the USB cable, “OK” on the PC disappears.
- 7) The unit is automatically started up.

[T&D Execution]

- 8) Execute T&D. For procedures, refer to the function test of unit’s board.

<Function test of unit’s board>

[Preparation] (Equipment required)

Wired remote controller

AC adaptor and AC cord

AV cable (Only for model equipped with TV output function)

Display with composite input (Only for model equipped with TV output function)

[Inspection]

- a) Connect the AC adaptor to the unit. The OS stored on the HDD starts up.
- b) Using the buttons on the front of unit, select T&D from the menu displayed on the LCD.
- c) When T&D is selected, the menu to select an item to be tested appears on the LCD.
Select [function test (MP)].
- d) According to the instruction displayed on the LCD, operate (Press the button.).
- e) When operating according to the instruction, the LCD becomes entirely black/white, check visually.
- f) When “Connect Controller” appears, connect the remote controller to the Headphone jack and operate the button on the remote controller according to the instruction displayed on the LCD.
- g) When “Disconnect Controller” appears, plug out the remote controller.
- h) If the unit has no TV out, jump to step k). If the unit has the TV out, “Connect TV out” appears, When this message appears, connect the AV cable to the Headphone jack.
(Depending on plugging out the remote controller, “Disconnect TV out” may not appears and the LCD display may become “OFF. But, this is not a trouble. Irrespective of this, connect the AV cable to the Headphone jack and proceed to the next step.)
- i) Confirm that the test pattern and “Push OK” appear on the display to which the AV cable is connected.
- j) Press “OK” button. Then, the test pattern disappears.
- k) “PASS” appears on the LCD. (“When “PASS” appears, the inspection is finished.)
- l) Press “Power” button to suspend the unit, and then plug out the AC adaptor.

[Note]

Before conducting the inspection, the specified T&D software must be installed.

[Transfer of FW for factory setting]

- 9) Transfer the FW for factory setting in the same manner as in step 4). Terminate Ottoman.exe once. Start up newly the [Transfer Program (Ottoman.exe) on the PC and select the scenario file (*.ini) in which files to be transferred are described. Ottoman.exe and the scenario file are provided on the CD-ROM (Material No.: 360058245). Names for the destination-wise stored folder and file are different depending on the destination. The relationship between destination and folder is shown on the table below.

Table Destination and Folder

Destination	Folder name	Scenario file name
Japan	OTTOMAN_DEL_JP	OTTOMAN_DEL_JP.ini
U.S.A.	OTTOMAN_DEL_US	OTTOMAN_DEL_US.ini

The menu display is also the same as in step 4). Check two points of (A) and (B) on the menu in step 4). These are different depending on the destination ((A) is same.) The display for every destination is as shown below.

Table Differences of display by destination (Differences are underlined.)

Destination	(A)	(B)
Japan	version 0.9.9.10	FILE DEL & TRANS PROG(<u>JP</u>) Ver.6423A
U.S.A.	version 0.9.9.10	FILE DEL & TRANS PROG(<u>US</u>) Ver.6423A

- 10) Wait for a while. Then, “OK” appears on the PC.
- 11) Remove the USB cable. At this moment, be careful not to touch the POWER button. By removing the USB cable, “OK” on the PC disappears. The unit is automatically started up.
- 12) The unit is automatically started up.

[Transfer of supplied data for factory setting]

- 13) Transfer the supplied data for factory setting in the same manner as in step 4). Terminate Ottoman.exe once. Start up newly the [Transfer Program (Ottoman.exe)] on the PC and select the scenario file (*.ini) in which files to be transferred are described. Ottoman.exe and the scenario file are provided on the CD-ROM (Material No.: 360058245). Names for the destination-wise stored folder and file are different depending on the destination. The relationship between destination and folder is shown on the table below.

Table Destination and Folder

Destination	Folder name	Scenario file name
Japan	OTTOMAN_SAMPLE_JP	OTTOMAN_SAMPLE_JP.ini
U.S.A.	OTTOMAN_SAMPLE_US	OTTOMAN_SAMPLE_US.ini

The menu display is also the same as in step 4). Check two points of (A) and (B) on the menu in step 4). These are different depending on the destination ((A) is same.) The display for every destination is shown below.

Table Differences of display by destination (Differences are underlined.)

Destination	(A)	(B)
Japan	version 0.9.9.10	TRANS SAMPLE COMTENTS(<u>JP</u>) Ver.6423A
U.S.A.	version 0.9.9.10	TRANS SAMPLE COMTENTS (<u>US</u>) Ver.6423A

- 14) Wait for a while. Then, “OK” appears on the PC.
- 15) Remove the USB cable. At this moment, be careful not to touch the POWER button of gigabeat S. By removing USB cable, “OK” on the PC disappears.
- 16) Hold down the Power key to suspend (Power OFF). Plug out the AC adapter.

3.5. When replacing the LCD and LCD backlight unit

3.5.1. Incorporating them into the LCD frame

Peel off the protective film from the LCD and LCD backlight, then incorporate them into the LCD frame. Guard against fingerprints and dust.

4. Troubleshooting

Shown below is the defect analysis procedure as a maintenance service.

Before repair (parts replacement), be sure to see “3. Cautions on repair”.

4.1. Anticipated defects

- 1) The unit will not turn on.
- 2) No sound comes out.
- 3) FM cannot be received.
- 4) The sound is odd.
- 5) The LCD display is odd.
- 6) Operating the buttons on the unit does not work.
- 7) Remote control does not work.
- 8) A USB connection cannot be established.
- 9) The battery cannot be recharged. (When battery-powered, the unit plays back only for a short time.)
- 10) The HDD is not recognized.

4.2. Defect analysis procedure as a maintenance service

4.2.1. The unit will not turn on.

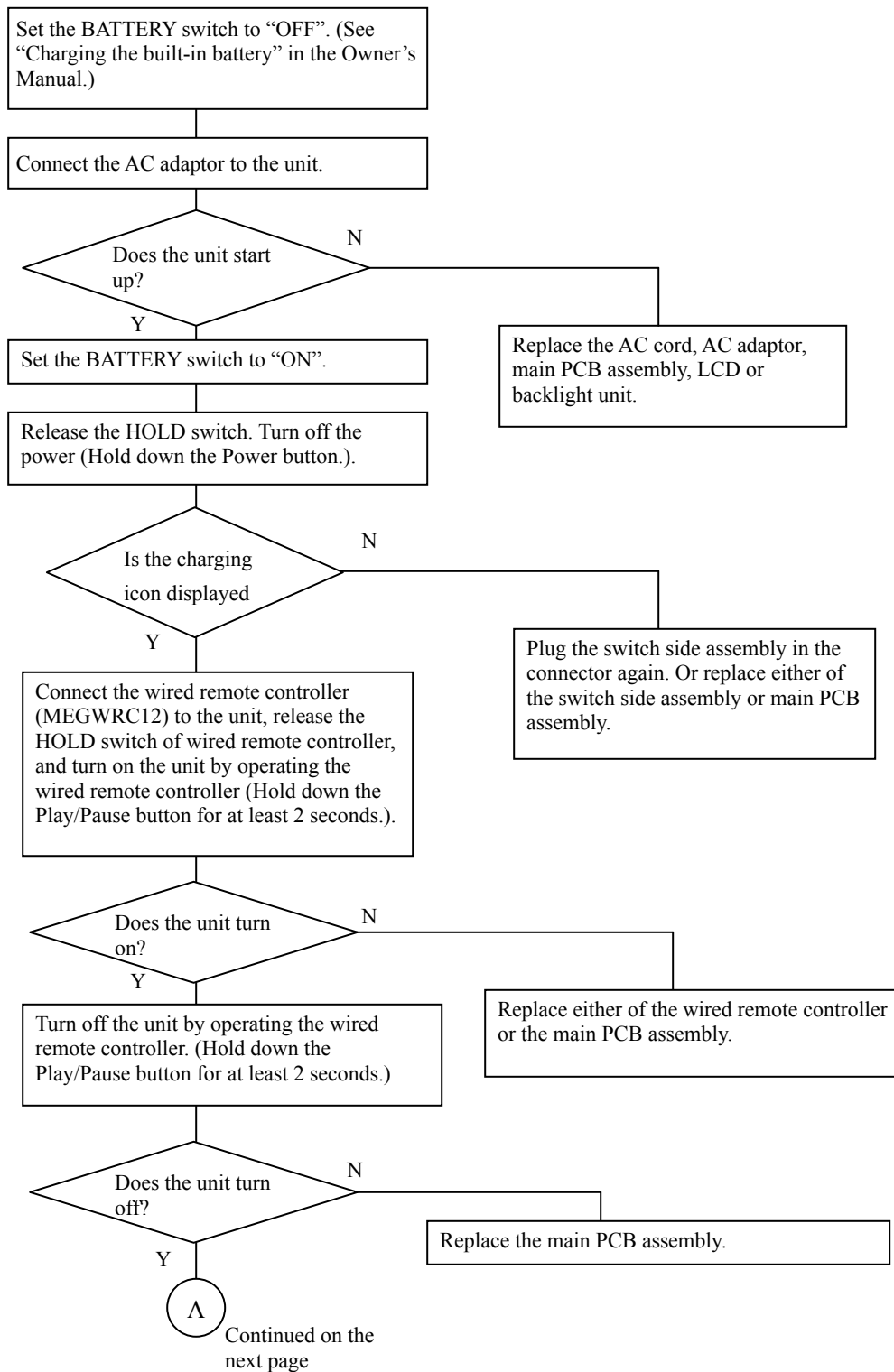

Continued from the previous page

A

If the unit turns on successfully, the owner may have set the BATTERY switch to "OFF" or have the battery discharged. Therefore, leave (recharge) the battery at least four hours as is. Then, remove the AC adaptor and try to turn on the unit.

Does the unit turn on?

N

Replace either of the main PCB assembly or the lithium ion battery.

Y

Explain the BATTERY switch and the recharge method to the owner.

4.2.2. No sound comes out.

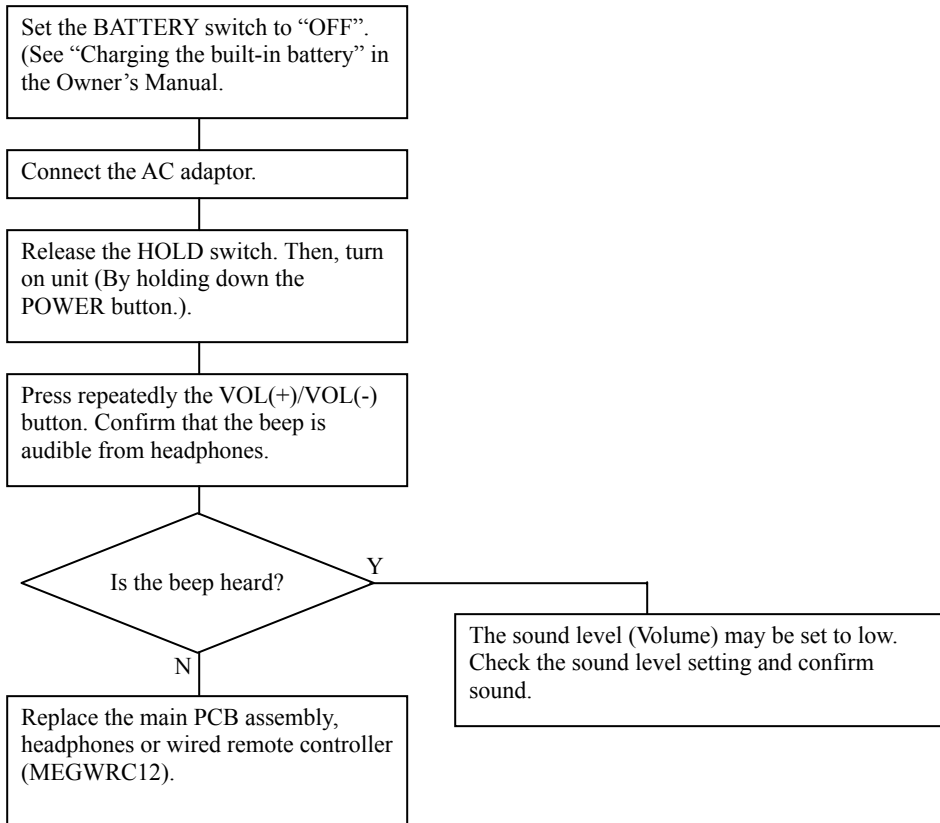

4.2.3. FM cannot be received.

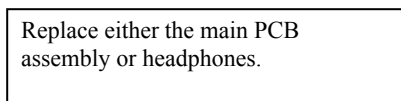

4.2.4. The sound is odd.

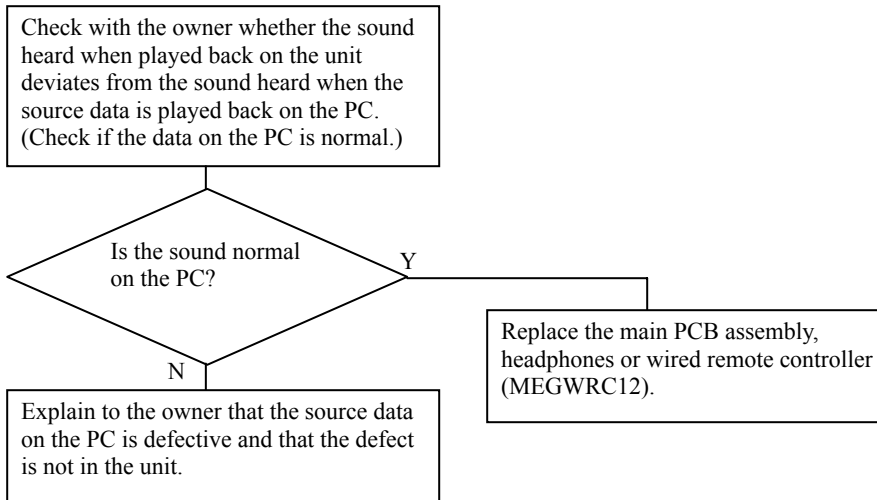

4.2.5. The LCD display is odd.

Replace the main PCB assembly, LCD or backlight unit. Or re-connect the connectors of LCD/backlight unit.

4.2.6. The buttons of unit do not work.

In case of buttons at the side of unit:
Replace either the switch side assembly or the main PCB assembly.
Or cable is reconnected.

In case of buttons on the front of unit:
Replace either of the SW top assembly or the main PCB assembly.
Or cable is reconnected.

In case of HOLD switch:
Replace the main PCB assembly.

In case of BATTERY switch:
Replace the rigid FPC assembly.

4.2.7. The remote controller does not work.

Replace either of the wired remote controller (MEGWRC12) or the main PCB assembly.

4.2.8. The USB connection fails.

Replace the main PCB assembly or USB cable.

4.2.9. The battery cannot be recharged. (When battery-powered, the unit plays back only for a short time.)

Conduct a hearing of how the owner has been using the unit. If he or she is suspected of having repeated at least 500 recharge-discharge operations, the battery life may expire. Replace the lithium ion battery. The play-back time (12 hours) of battery as specified in the catalogs is applicable when the WMA format sound is played back. Sound in MP3 format can also be played back for almost the same amount of time. However, sound in the WAV format can be played back for about three to four hours only. Explain this to the owner as well.

In all cases other than this, repair in the procedure mentioned below.

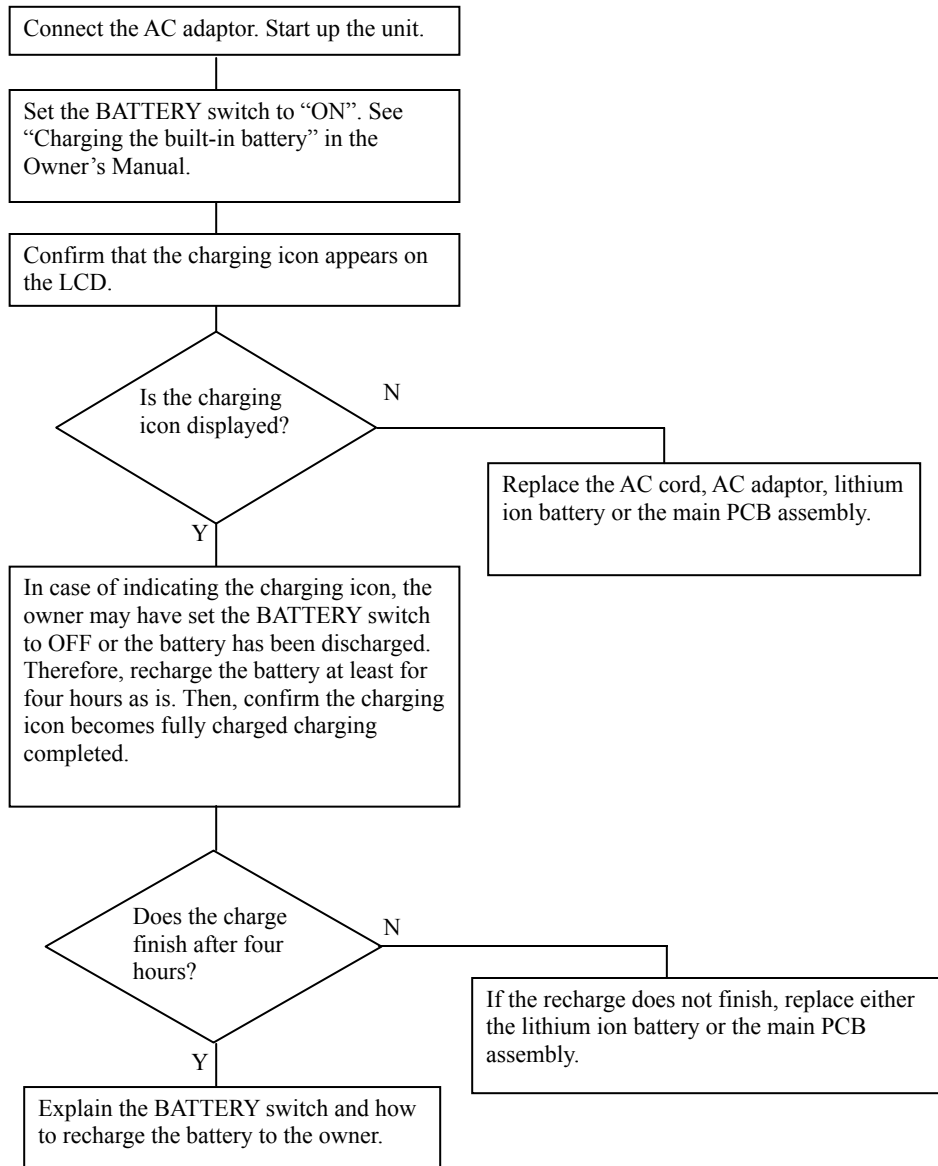

4.2.10. HDD is not recognized.

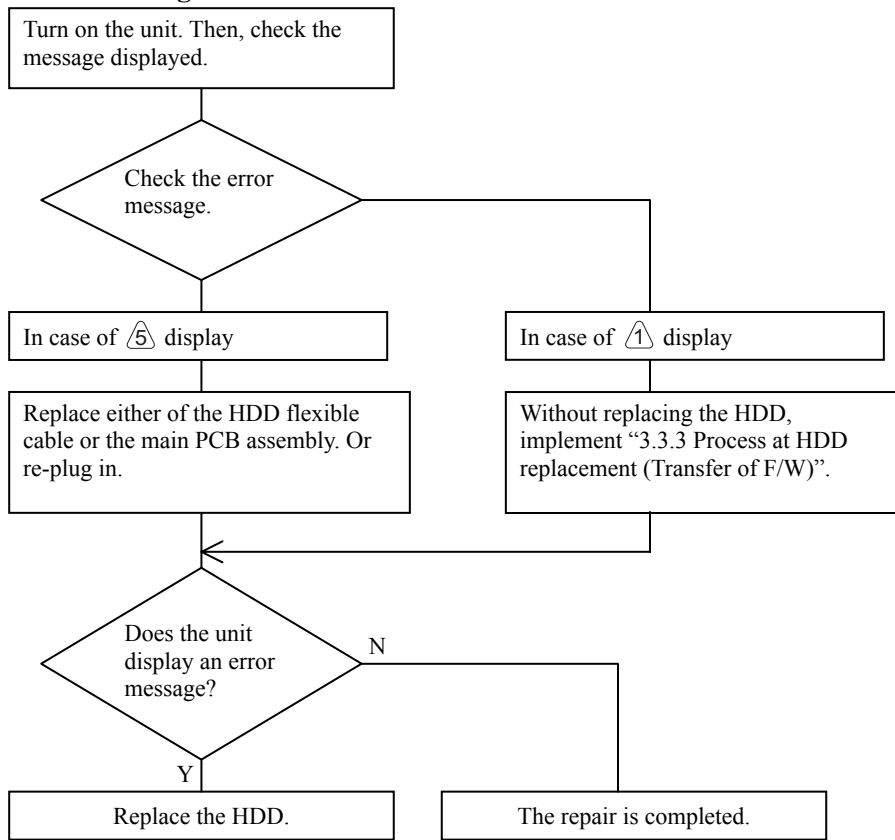

Fig. 5 display menu



Fig. 1 display menu







5. Procedure to confirm the unit's F/W version

To display the version, perform the steps below.





- 1) Hold down the POWER button to turn on the unit.
- 2) Select [settings] → [information] → [Portable Media Center] from the start menu.
- 3) Confirm the version displayed. Concretely, confirm that the version displayed is as follows.
Confirm “X.XXX, YYY “ in Version X.XX(YYY).
(The display for Japan is Version X.XX(YYY).)
Confirm “MMMM.NNNNNN” in Platform Version MMMM.NNNNNN.
(The display for Japan is Platform Version MMMM.NNNNNN.)
- 4) Hold down the POWER button. (The unit will turn off.)

6. Disassembling Procedures/Reassembling Procedures



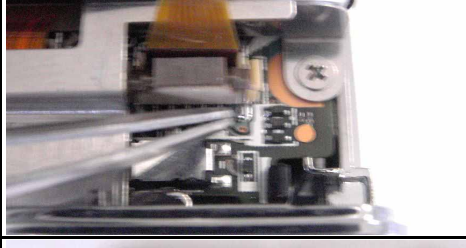
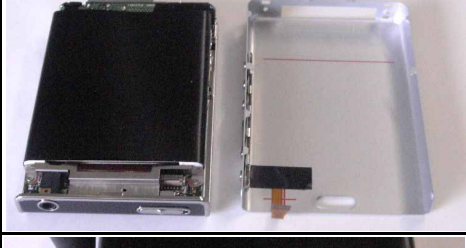
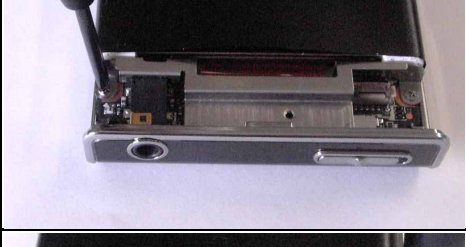

6.1. Disassembling Procedures

Step	Photo	Description	Note	Tool
1		Turn off the battery switch of unit (indicated by arrow).		
2		Rear of unit		
3		Remove the strap holder.		Philips screwdriver
4		Remove the screw at the side.		Philips screwdriver
5		Remove the screw at the side.		Philips screwdriver
6		Remove the screw at the bottom.		Philips screwdriver

Disassembling Procedures

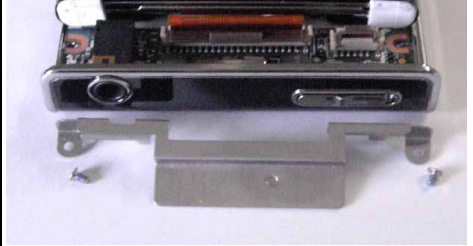
Step	Photo	Description	Note	Tool
7		Remove the screw at the bottom.		Philips screwdriver
8		Remove the back cover. Fix the back cover and slide the top cover in the arrow direction.		
9		The back cover and the top cover are removed.		
10		Remove the flexible cable leading from the side switch.	Release the lock of connector, lifting the lever upward.	Tweezers
11		The cable and the rear cover are removed.		
12		Remove the board fixing bracket.		Philips screwdriver
13		Remove the board fixing bracket.		Philips screwdriver

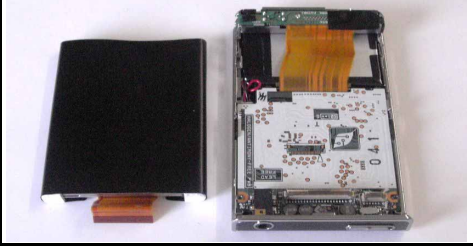
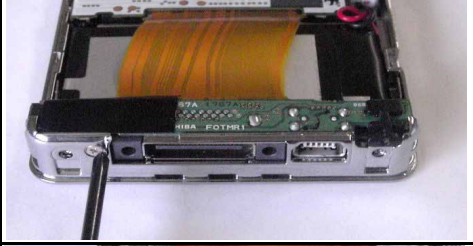
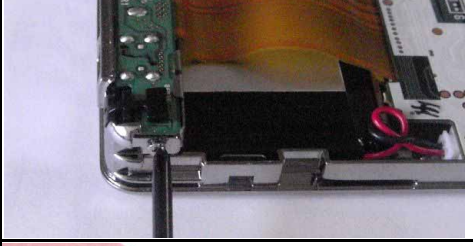
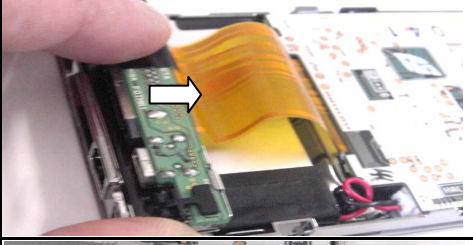
Disassembling Procedures

Step	Photo	Description	Note	Tool
14		The board fixing bracket is removed.	bracket 1 piece, screw 2 pieces	
15		Remove the HDD flexible cable.	Release the lock, lifting the connector lock upward.	Tweezers
16		The HDD is removed.		
17		Remove the terminal board. Remove the screw at the bottom.	The terminal board is fixed with the fixing bracket and two screws.	Philips screwdriver
18		Remove the terminal board. Remove the screw at the side.		Philips screwdriver
19		Slide in the arrow direction and remove the board, lifting up.		
20		Remove the battery connector and battery.		

Disassembling Procedures

Step	Photo	Description	Note	Tool
21		The battery is removed.	Release the lock, lifting up the lock lever of CN1.	
22		Remove the SW sheet bracket and then the SW button.	Release the lock with the flathead screwdriver inserted through the gap at the side and remove it.	Flathead screwdriver
23		The SW sheet bracket is removed.		
24		Remove the SW sheet bracket and then the SW button.		Philips screwdriver
25		Remove the LCD block and then LCD frame, unlocking four claws.		
26		Release the lock of CN2 and remove the FFC cable.		Tweezers
27		Release the lock of CN4 and remove the FFC cable.		Tweezers



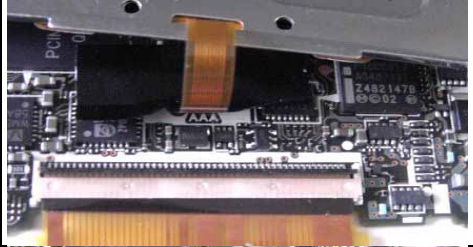
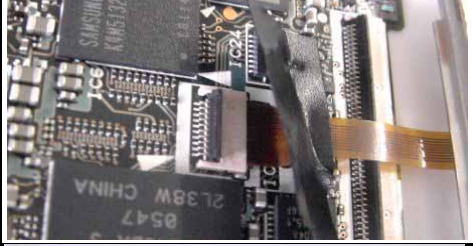
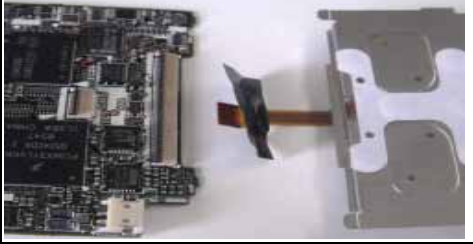

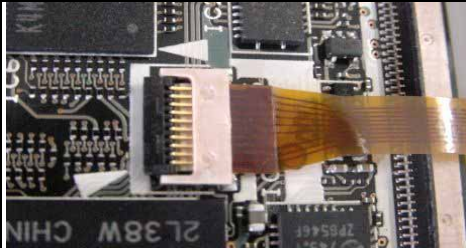
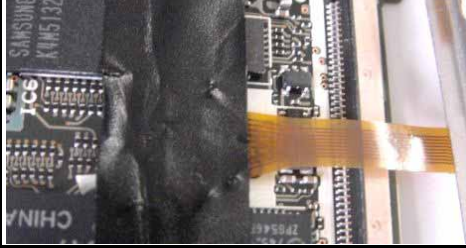
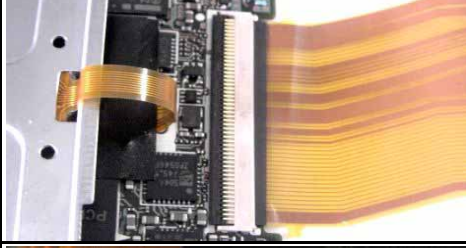
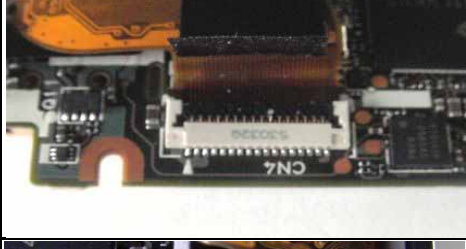
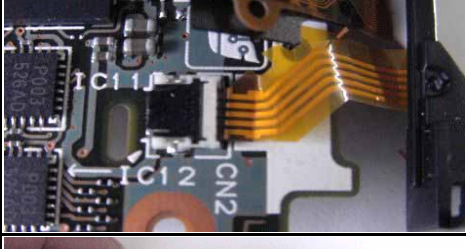
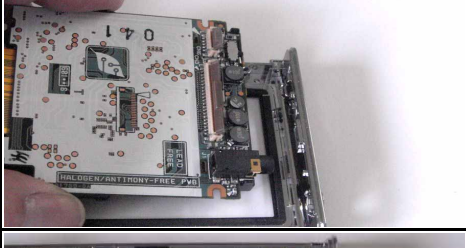
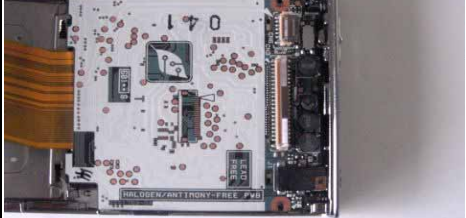

Disassembling Procedures

Step	Photo	Description	Note	Tool
28		The LCD block is removed.		
29		Remove the FFC cable of terminal board, unlocking.		
30		Remove the FFC cable leading from SW, unlocking.		
31		The board removal is finished.		



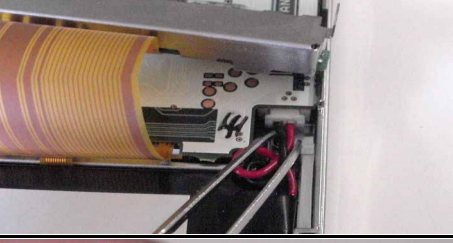
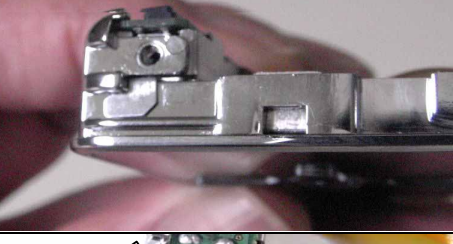

Disassembling Procedures

6.2. Reassembling Procedures

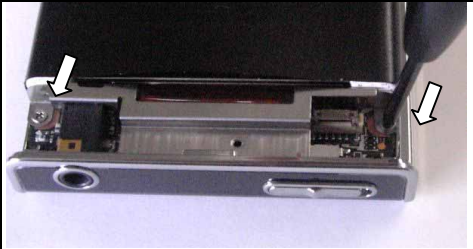
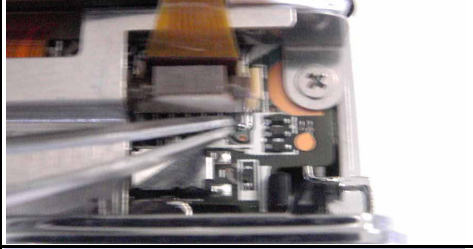
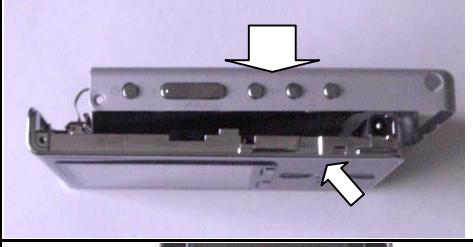

Step	Photo	Description	Note	Tool
1		<p><Board Assembling> Insert the FFC cable leading from SW.</p>	Be sure to lock.	
2		Affix securely the protection tape to the original position.		
3		Connect the FFC cable of terminal board.	Be sure to lock.	
4		<p><Building-in of LCD block> Connect the FFC cable of LCD.</p>	Be sure to lock. Affix the protection tape to the original position.	
5		Connect the FFC cable of LCD.	Be sure to lock.	
6		Fix the LCD block to the board and build it in the front panel.	Install the headphones terminal side of it first.	
7		The board is fixed to the front panel.		

Step	Photo	Description	Note	Tool
8		The board, LCD, terminal board and SW sheet bracket are fixed to the front panel.	Place the SW button on the original position.	
9		Place the SW button on the original position and fix the SW sheet bracket.	Push it in until it is locked by the bracket.	
10		Install the battery.	Insert securely the connector.	Tweezers
11		<Installing the terminal board> Sandwich the terminal board fixing bracket as shown and fix it.		
12		Fix the terminal board bracket with the screw.	Install the battery SW knob indicated by arrow.	Philips screwdriver
13		Fix the terminal board bracket with the screw.		Philips screwdriver
14		Install the HDD. Insert the FFC cable in the connector.	Be sure to lock.	Tweezers

Reassembling Procedures

Step	Photo	Description	Note	Tool
15		Install the board fixing bracket with two screws.		Philips screwdriver
16		Install the flexible cable leading from side switch to the connector.		Tweezers
17		Align the back cover and the top cover with the slide groove.	Slide groove (Indicated by arrow)	
18		Fix the back cover. Slide the front cover in the arrow direction and fix it.		
19		Tighten the screw at the bottom. (2 pieces)		Philips screwdriver
20		Tighten the screw at the bottom. (2 pieces)		Philips screwdriver
21		Tighten the screw at the side.		Philips screwdriver

Reassembling Procedures

Reassembling Procedures	Step	Photo	Description	Note	Tool
	22		Tighten the screws at the side.		Philips screwdriver
	23		Install the strap holder.		Philips screwdriver
	24		Assembling is finished.		

7. Exploded View

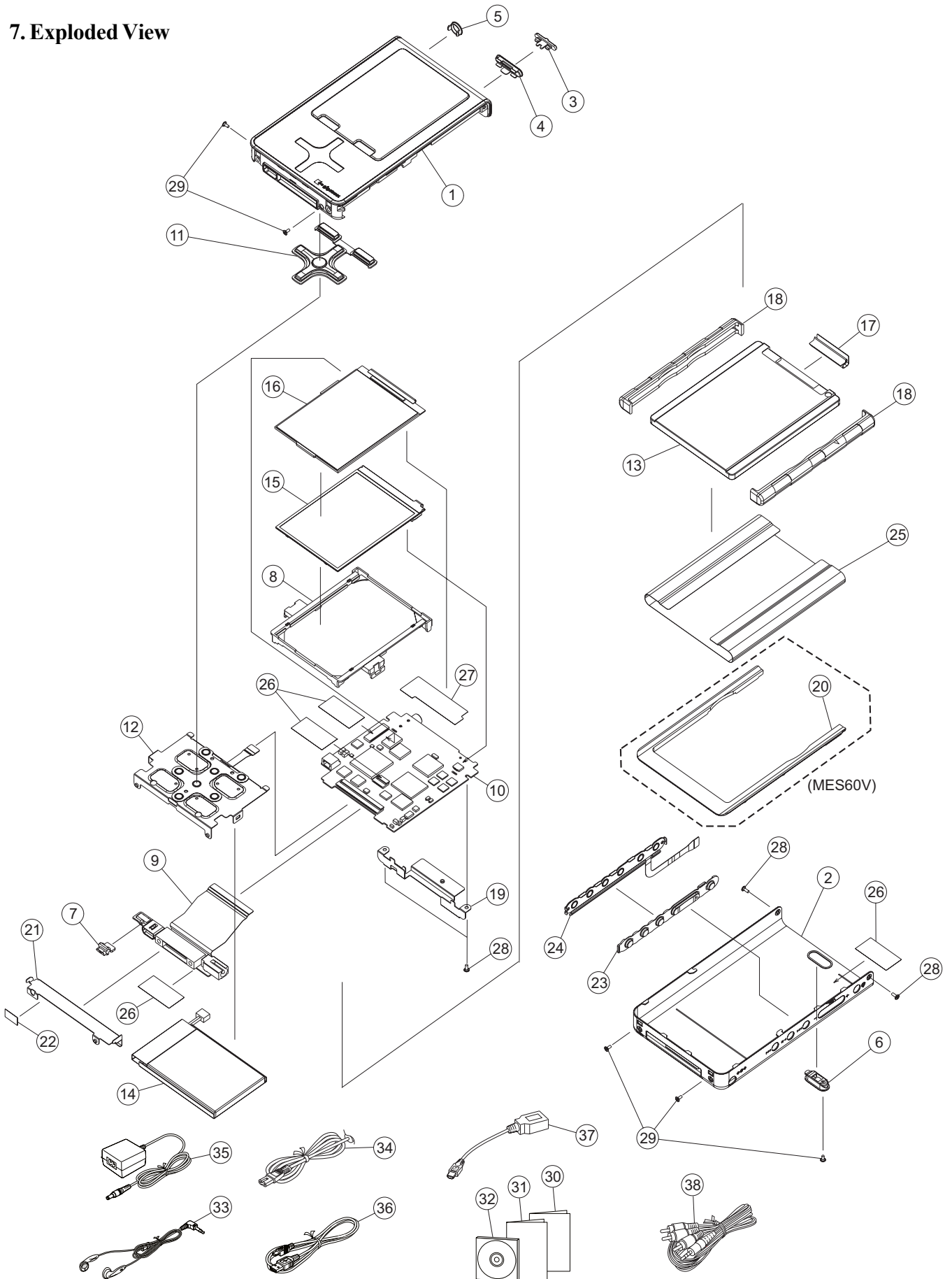

8. Parts List

gigabeat S-SERIES-(US/CA) : MES30VW ,MES60VK

Safety Parts	Location No.	Sevice No.	Parts No.	Description	Model	Remarks
	1	P000469230	AM0007928110	TOP PANEL ASSY BLACK	MES60VK	
		P000468880	AM0007928120	TOP PANEL ASSY WHITE	MES30VW	
	2	P000469090	PM0025188130	BASE T1 WW30	MES60VK	
		P000469260	PM0025189130	BASE T2 WW60	MES30VW	
	3	P000469100	PM0025192110	HOLD BUTTON		
	4	P000469110	PM0025193110	HOLD RING		
	5	P000469120	PM0025194110	HP RING		
	6	P000469130	PM0025195110	STRAP HOLDER	MES30VW	
		P000469220	PM0025449110	STRAP HOLDER T2	MES60VK	
	7	P000469140	PM0025196110	BATTERY BUTTON		
	8	P000469150	PM0025197110	LCD FRAME		
	9	P000468950	G8FC0001L110030	RIGID FPC ASSY		
	10	P000468940	G8FC0001L110020	MAIN PCB ASSY FMTV		
	11	P000469200	AM0007933110	SW BUTTON TOP ASSY-B	MES60VK	
		P000468890	AM0007933120	SW BUTTON TOP ASSY-W	MES30VW	
	12	P000468910	AM0008573110	SW TOP ASSY		
	13	P000449660	HDD1642CZK	HDD 30GB SHORT-FORM	MES30VW	
		P000449600	HDD1724CZK	HDD 60GB SHORT-FORM	MES60VK	
	14	P000468930	G71C0006M110	LITHIUM-ION BATTERY 1UPF383450-TBF		
	15	P000468970	GDM330000077	LCD BACKLIGHT CBL1759A		
	16	P000449380	GDM330000072	LCD UNIT LTM024D362		
	17	P000449300	G5B001592000	HDD-FPC FBHMH1		
	18	P000449530	PM0023127110	HDD RUBBER		
	19	P000469160	PM0025207110	HDD PLATE		
	20	P000469210	PM0025204110	HDD-SPACER	MES60VK	
	21	P000469180	PM0026063110	IO PLATE		
	22	P000469190	PM0026064110	INS IO SPACER		
	23	P000468900	AM0007934110	SW BUTTON SIDE ASSY		
	24	P000468920	AM0008574110	SW SIDE ASSY		
	25	P000469170	PM0025487110	INS HDD		
	26	P000469080	PM0024232110	INS LCD CON		
	27	P000469060	PM0023132110	INS LCD FPC		
	28	P000469070	PM0023728210	SCREW M1.4x4 TAPPING-SR		
	29	P000404330	PM0012147010	SCREW M1.4x2.5		
⚠	30	P000469020	GX1C000CJ210	QUICK-START ENGLISH US/CA/AU	US	
		P000469030	GX1C000CJ310	QUICK-START FRENCH CA	CA	
⚠	31	P000469040	GX1C000CJ510	SAFETY GUIDE ENGLISH US/CA/AU	US	
		P000469050	GX1C000CJ610	SAFETY GUIDE FRENCH CA	CA	
⚠	32	P000469000	GX0C000EV210	COMPANION-CD 1.0US (1.0NA)		
	33	P000449360	GDM300000214	HEAD-PHONE UX0317-01-0R		
⚠	34	P000441240	GDM900000706	AC-CORD VM0228A-VM0296 2M NON-PB		
⚠	35	P000449310	G71C0002F111	AC-ADAPTER ADP-15HH-AE		
	36	P000449390	GDM900000854	USB-CABLE IQ-050253A		
	37	P000468980	GDM900001027	USB-CONVERSION-CABLE IQ-050535B		
	38	P000468990	GDM900001028	AV-CABLE IQ-050932		

Specifications

Audio format	<ul style="list-style-type: none">• WMA (Windows Media Audio)• WMA 9 Lossless• MP3 (MEPG-1 Audio Layer3)• WAV (PCM)
Video format	WMV (Windows Media Video)
Photo format	JPEG (9000 x 6000 max.)
Sampling frequency	8 to 48 kHz
Bit rate	(Audio data) 4 to 320 kbps (Video data) Less than or equal to 800kbps Bit rate of the video data is that of audio + video.
Recording media	S60V Internal hard disk 60 GB (*1) S30V Internal hard disk 30 GB (*1)
Maximum Recording time	(Audio data) S60V Approx. 996 hours (*2) (at 128 kbps bit rate) S30V Approx. 498 hours (*2) (at 128 kbps bit rate) (Video data) S60V Approx. 255 hours (*2) (at 500 kbps bit rate) S30V Approx. 127 hours (*2) (at 500 kbps bit rate)
Continuous playback time	(Audio data) Approximately 12 hours (*2): 128kbps, 44.1Hz WMA audio tracks, backlight off (Video data) Approximately 2.5 hours (*2): 500kbps WMV video <ul style="list-style-type: none">• Excluding content protected with Windows Media DRM10• The built-in battery fully charged using the AC adapter.• Normal temperature (25°C), Factory-default volume <p>The continuous playback time is a reference value but is not guaranteed, since the actual playback time will vary depending on the operating condition, ambient operating temperature, the number of times the built-battery has been recharged, etc.</p> <p>Even under allowable operating conditions, using the gigabeat at low temperature will result in a reduction of the maximum continuous playback time.</p> <p>Playback with the Harmonics on, WAV audio data, and WMA 9 Lossless use more battery power for playback than MP3 and WMA. Continuous playback time will be reduced accordingly.</p>
Operating conditions	Temperature: 5 to 35°C, Humidity: 30 to 80% (RH) (No condensation)
Color screen	2.4 inch diagonal QVGA low temperature polysilicon TFT color panel (*4)
FM Radio	87.5 MHz to 107.9 MHz
USB port	USB2.0/USB1.1 (*3)
Headphone /	3.5 mm jack/stereo type
V-OUT jack	Load impedance 16Ω
S/N ratio	95 dB or higher
Weight (main unit only)	S60V Approx. 140 g (4.9 ounces) S30V Approx. 127 g (4.45 ounces)
External dimensions (excluding projections)	S60V Approx. 59.9 mm x 16.2 mm x 99.9 mm (2.35 inches x 0.63 inches x 3.93 inches) (width x height x depth) S30V Approx. 59.9 mm x 13.2 mm x 99.9 mm (2.35 inches x 0.51 inches x 3.93 inches) (width x height x depth)
Power	Rechargeable lithium-ion battery, AC adapter, USB charging
AC adapter	Type name: ADP-15HHA Input power condition: 100 to 240 VAC, 50/60Hz Rated output: 5V DC, 3A

*1: 1 Gigabyte(GB) means $10^9 = 1,000,000,000$ bytes using powers of 10. The operating system of the gigabeat and certain computer operating systems, however, calculate storage capacity using powers of 2 for the definition of 1 GB $= 2^{30} = 1,073,741,824$ bytes and therefore show less storage capacity. Available storage capacity is also less as the gigabeat includes a pre-installed operating system, pre-installed software applications, and/or media content. Actual formatted capacity may vary.

*2: These values are for reference purposes only and may vary.

*3: It is necessary to operate the USB2.0 interface with the USB2.0 interface preinstalled or extended PC. It operates as USB1.1 when connecting it with the USB1.1 interface.

*4: The color LCD is made with extremely high-precision technology. There may be the existence of display (pixels) that might not light or might be lit all the time; however, please note that this does not constitute malfunction of the product and is not covered by your warranty.

Note

- This product complies with the above specifications.
- Design and specifications are subject to change without notice.
- This product may not be compatible with features and/or specifications that may be added in the future.
- The illustrations and screen displays appearing in this manual may differ somewhat from the actual appearance.
- The display position and other aspects of the icons are subject to change.

Combination of Sampling Frequency and Bit Rate

The tracks that can be played on the gigabeat have the following combinations of sampling frequency and bit rate. Tracks with another combination may not play properly.

MP3 (stereo)

Sampling frequency: 8, 16, 22.05, 44.1, 48 kHz

Bit rate: 32 to 320 kbps

MP3 (mono)

Sampling frequency: 8, 11, 16, 22.05, 32, 44.1 kHz

Bit rate: 16 to 64 kbps

WMA (stereo)

Sampling frequency: 8, 16, 22.05, 32, 44.1, 48 kHz

Bit rate: CBR 32 to 320 kbps, VBR 32 to 355 kbps

WMA (mono)

Sampling frequency: 8, 11, 16, 22.05, 32, 44.1 kHz

Bit rate: CBR 5 to 48 kbps

WMA (VOICE)

Sampling frequency: 8, 11, 16, 22.05, 32, 44.1 kHz

Bit rate: 4 to 20 kbps

WAV (stereo/mono)

Sampling frequency: 8, 16, 22.05, 32, 44.1, 48 kHz

Bits rate: Uncompressed

WMA 9 Lossless

Sampling frequency: 8, 16, 22.05, 32, 44.1, 48 kHz

PC Requirements (*1)	
● Operating System	: Microsoft® Windows® XP Home Edition / XP Professional / XP Media Center Edition (Windows XP Service Pack 2 is recommended.)
● CPU	: 300MHz or faster (1.5GHz is recommended)
● RAM	: 128MB or more (512MB is recommended)
● Hard disk space	: 100MB or more
● Interface	: USB 2.0 / USB 1.1 (*2)
● Others	: CD-ROM Drive

*1: Only PCs with pre-installed operating systems are supported. Macintosh® computers and OS are not supported.

*2: In order for the device to transfer information using USB 2.0, the USB 2.0 protocol must be installed on the PC. If the PC can only transfer at USB 1.1 speeds, then the device will transfer information using USB 1.1.

Perform the following procedures before using the gigabeat. Windows Media Player 10 and the Owner's Manual are installed.

To transfer music, video and photo data to the gigabeat via PC, use Windows Media Player 10.

Note

- Even when Windows Media Player 10 is already installed on the PC, continue the installation procedure. Files necessary to work with the gigabeat will be installed on the PC.
- 1 Insert the included CD-ROM into the PC.
- 2 Click the "Install Windows Media Player 10" button.
Even when Windows Media Player 10 is already installed on the PC, continue the installation procedure. Files necessary to work with the gigabeat will be installed on the PC.
- 3 Follow the on screen instructions

Trademarks

- gigabeat and Plus Touch are trademarks of Toshiba Corporation.
- Microsoft, Windows, Windows Media and Windows Mobile are either registered trademarks or trademarks of Microsoft Corporation in the United States and/or other countries.
- Adobe, the Adobe logo and Reader are trademarks or registered trademarks of Adobe Systems Incorporated in the United States and/or other countries.
- Macintosh is a registered trademark of Apple Computer, Inc.
- The product names referred to in this manual may be registered trademarks or trademarks of their respective companies.

TOSHIBA CORPORATION

1-1, SHIBAURA 1-CHOME, MINATO-KU, TOKYO 105-8001, JAPAN