

TOSHIBA

CASSETTE STEREO DECK

PC-5060



SPECIFICATIONS

Tape Speed:	1-7/8 ips. (4.8cm/sec.)	Recording and Play-	
Track:	4-track 2-channel Stereo	back Connector:	Input Impedance 5K Ω (TZ) 4.7K Ω (TE)
Recording System:	AC Bias		Load Impedance ... 50K Ω
Erasing System:	AC Erasure	Power Source:	AC 120V, 60 Hz (TZ) AC 220/240V, 50 Hz (TE)
Frequency Response:	40 to 15,000 Hz (Chrome Tape)(TZ) 40 to 12,500 Hz (Chrome Tape) (TE)	Power Consumption:	15W
Input Jacks:	Microphone Jacks 2 Maximum Sensitivity0.25mV(TZ),0.5mV(TE) Input Impedance ..600 to 10K Ω (TZ), 4.7K Ω (TE) Line Input Jacks 2 Maximum Sensitivity 0.1V Input Impedance 50K Ω	Semiconductors:	Transistors 34 Diodes 31 IC's 4
Output Jacks:	Stereo Headphone Jack 1 Load Impedance 8 Ω Line Output Jacks 2 Reference Output 0.4V Load Impedance 50K Ω	Signal-to-noise Ratio:	55dB (NAB Peak Level in chrome tape, without DOLBY)
		Distortion Factor:	2% (TZ), 3% (TE)
		Wow and Flutter:	0.08%WRMS (TZ) 0.2% (TE)
		Fast Forwarding/ Rewinding Time:	Within 90 sec. (Using C-60)
		Dimensions:	17-29/32 (W) x 5-7/8 (H) x 13-1/8 (D) inches
		Weight:	Approx. 18 lbs.

TABLE OF CONTENTS

	Page
1. PARTS LOCATIONS	3
2. DISASSEMBLY INSTRUCTIONS	4
3. TECHNICAL POINTS	5
4. BLOCK DIAGRAM	5
5. ADJUSTMENT PROCEDURE	6 ~ 10
RECORD/PLAYBACK HEAD ADJUSTMENT	7
PLAYBACK SENSITIVITY ADJUSTMENT	7
LEVEL METER ADJUSTMENT	7
RECORD INPUT SENSITIVITY ADJUSTMENT	8
BIAS LEAK ADJUSTMENT	9
BIAS CURRENT ADJUSTMENT	9
RECORD/PLAYBACK LEVEL ADJUSTMENT	10
6. ELECTRICAL PARTS LOCATIONS	11 ~ 14 and 16
Jack P.C. Board (For TZ)	11
Jack P.C. Board (For TE)	11
ASO P.C. Board	11
Push Switch P.C. Board (For TZ)	12
Push Switch P.C. Board (For TE)	12
Push Switch P.C. Board	13
Dolby P.C. Board	13
Power Supply P.C. Board	14
Main Amplifier P.C. Board	16
7. SCHEMATIC DIAGRAM	15
8. EXPLODED VIEW (MECHANISM)	17
9. EXPLODED VIEW (CABINET)	18
10. PARTS LIST	19 ~ 23

PARTS LOCATIONS

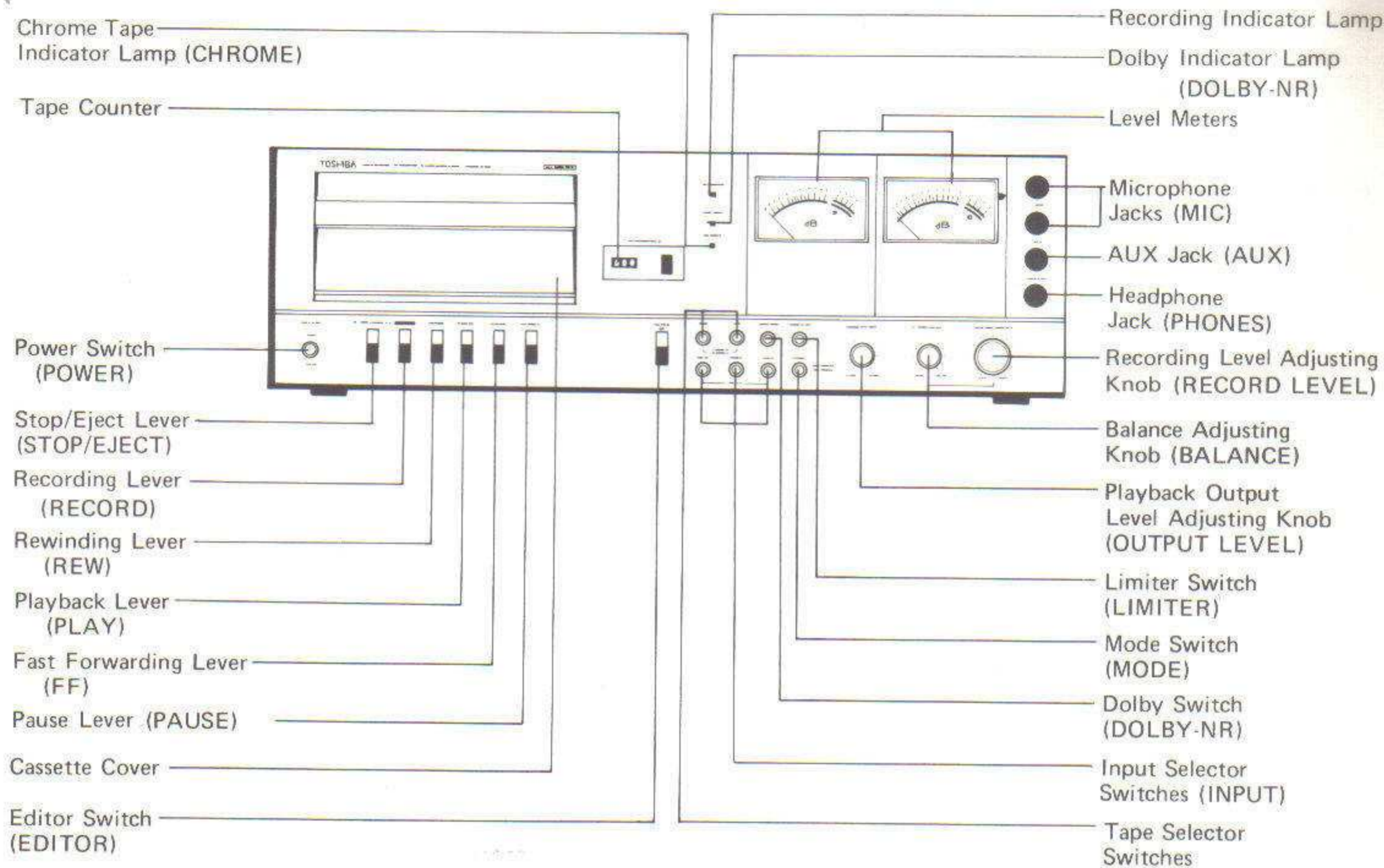

Figure 1. Front View

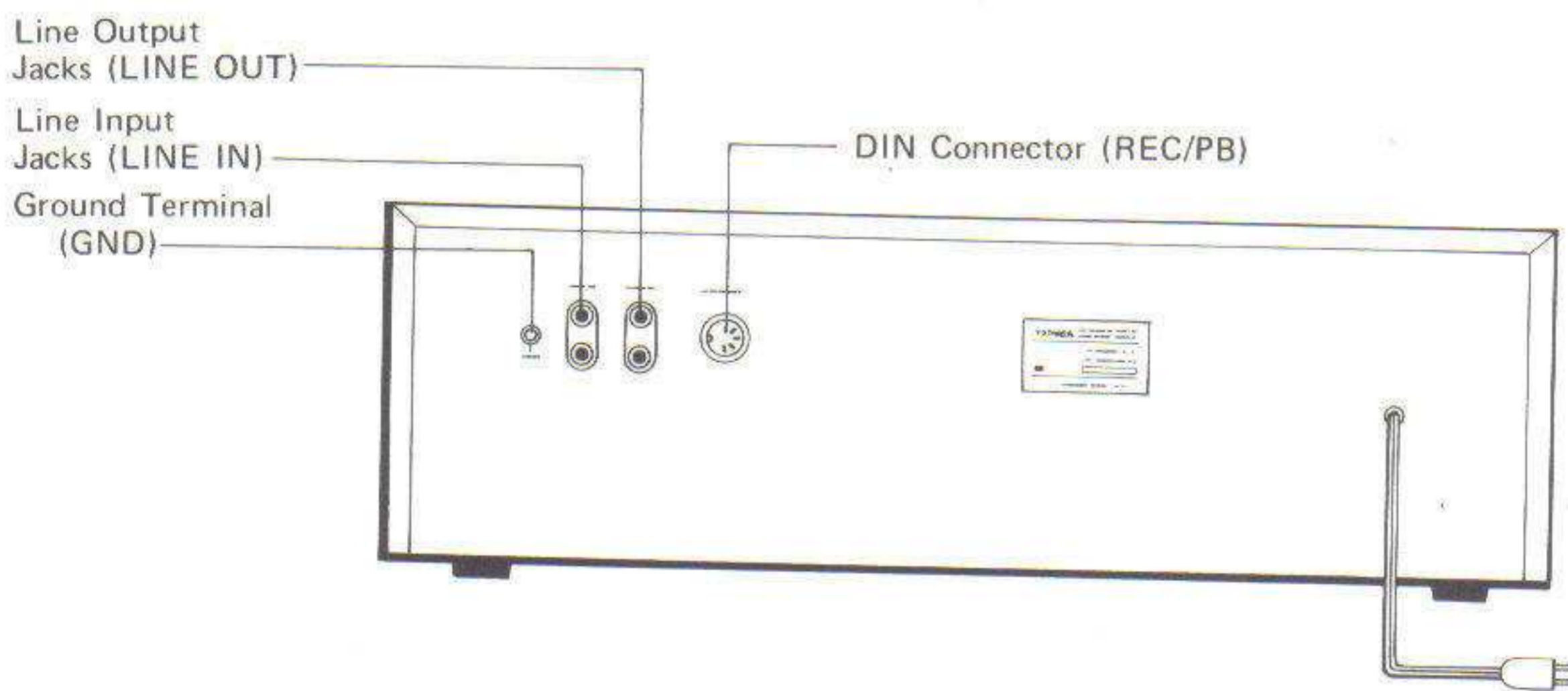

Figure 2. Back View

DISASSEMBLY INSTRUCTIONS

TOP COVER REMOVAL

1. Remove four screws at right and left sides and one screw at the Jack Plate. (See Figure 3).
2. Remove the Top Cover extending its both sides slightly outward.



Figure 3.

FRONT PANEL REMOVAL

1. Pull out three knobs (OUTPUT LEVEL, BALANCE and RECORD LEVEL). (See Figure 4).
2. Remove five screws at the Bottom Cover. (See Figure 5).
3. Remove four screws at the Bottom of the Front Panel. (See Figure 6).
4. Remove three screws at the Top of the Front Panel. (See Figure 7).
5. Remove the Front Panel.

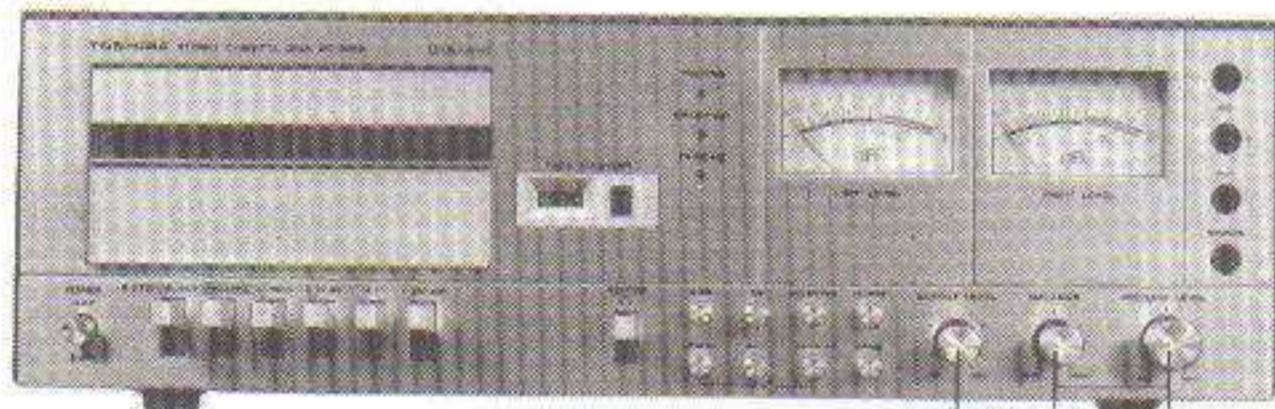

Playback Output Level Adjusting Knob
Balance Adjusting Knob
Recording Level Adjusting Knob

Figure 4.

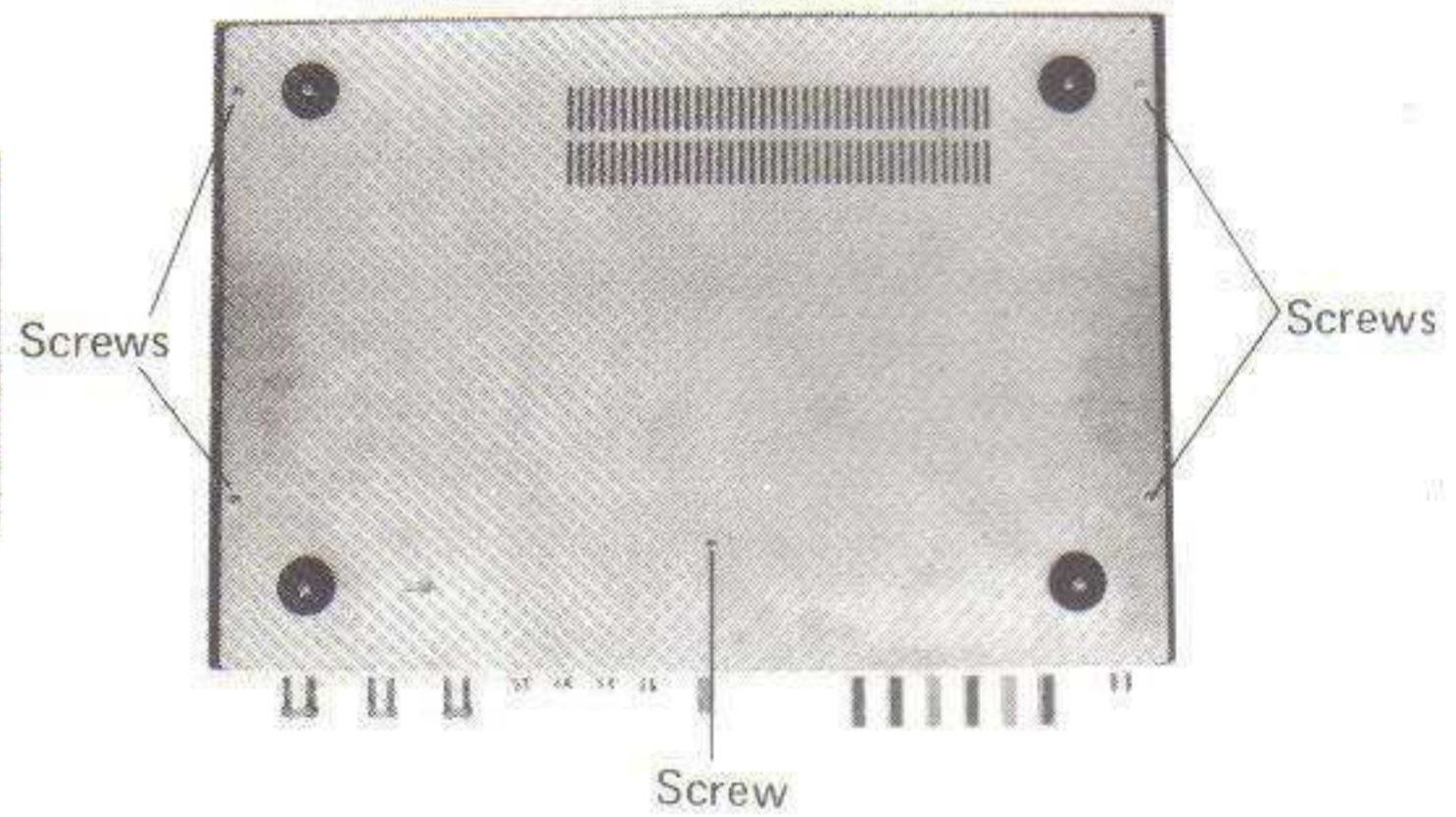

Figure 5.

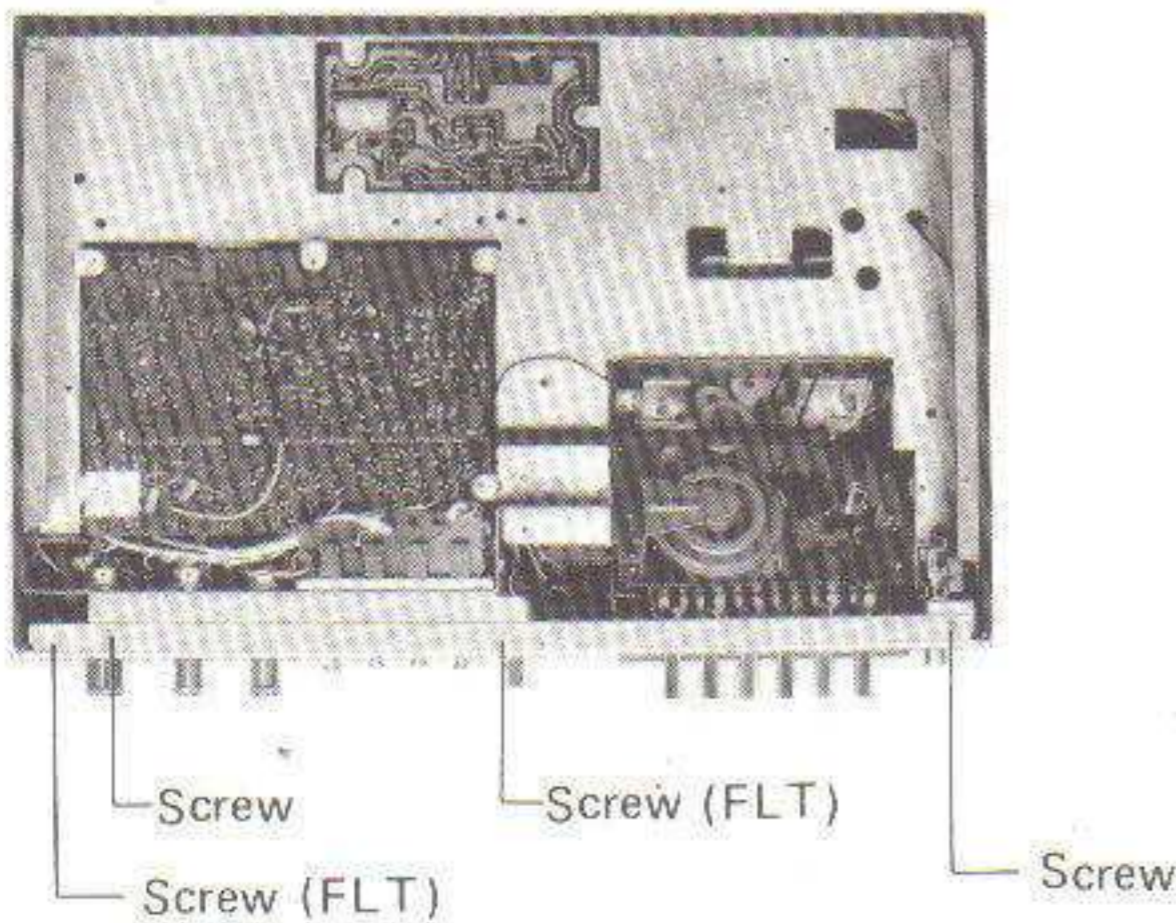

Figure 6.

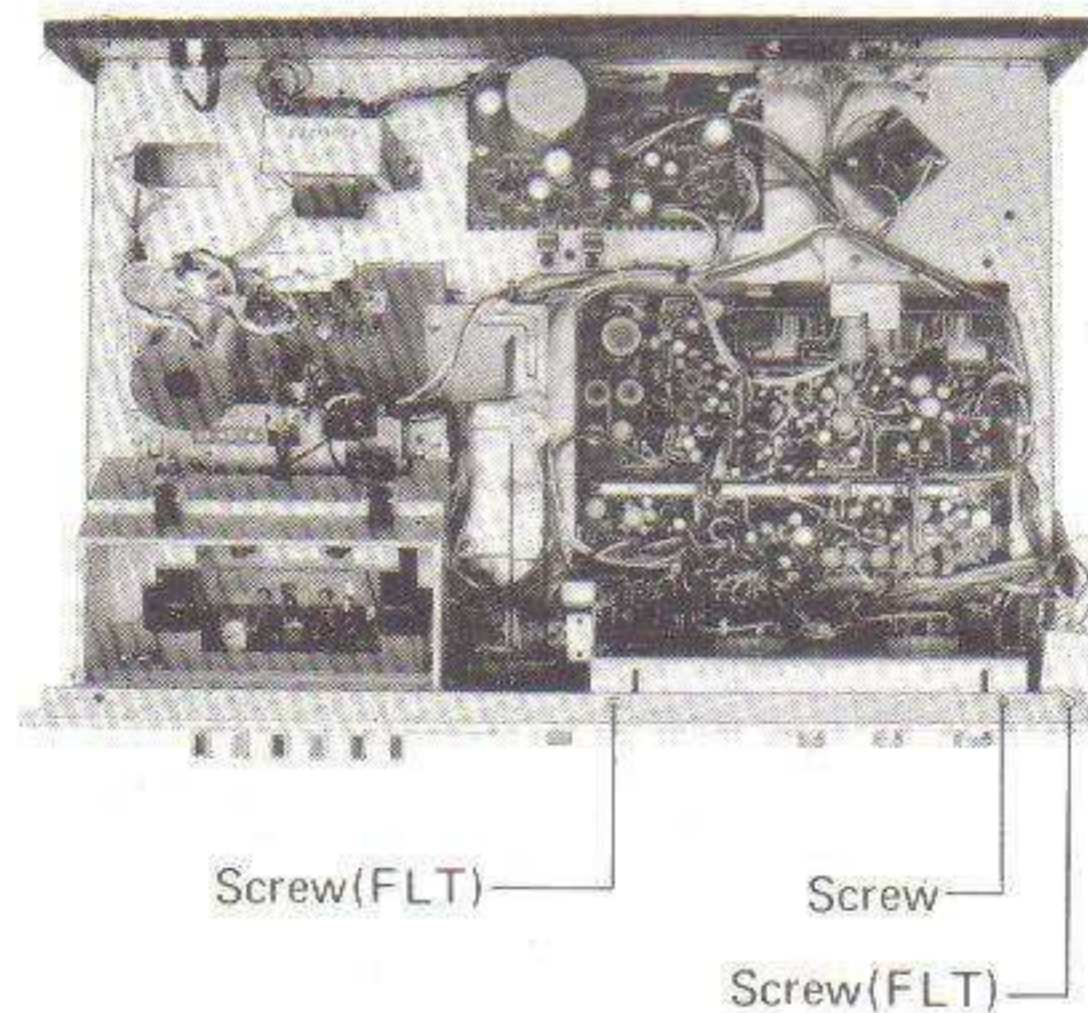

Figure 7.

TECHNICAL POINTS

ALL OPERATIONS ARE POSSIBLE AT FRONT PANEL

The operation of this deck is designed the same as Hi-Fi amplifier, and it is possible to put this deck in "audio rack".

TAPE SELECTOR SWITCHES FOR BIAS AND EQUALIZER

This deck has two independent tape selector switches for Bias and Equalizer and is available for various high technics in recording or playback.

AUTO TAPE SELECTOR

This deck has a special tape selector, Auto Tape Selector which detects the hole of chrome tape and changes Bias and Equalizer automatically.

EDITOR SWITCH

This deck has a convenient switch to cut input signal for tape editing.

DOLBY SYSTEM

This is noise reduction system, and available for better sound reproduction without any influence to sound quality. CAUTION: Dolby system is a registered mark of "Dolby L. Z."

AUTOMATIC STOP SYSTEM BY STATIC CAPACITY

Stops the tape travel automatically when the tape is wound up completely during recording, playback, fast forwarding or rewinding.

Long life and high reliability of this Automatic Stop System are secured by the employment of the non-contact static capacity method.

BLOCK DIAGRAM

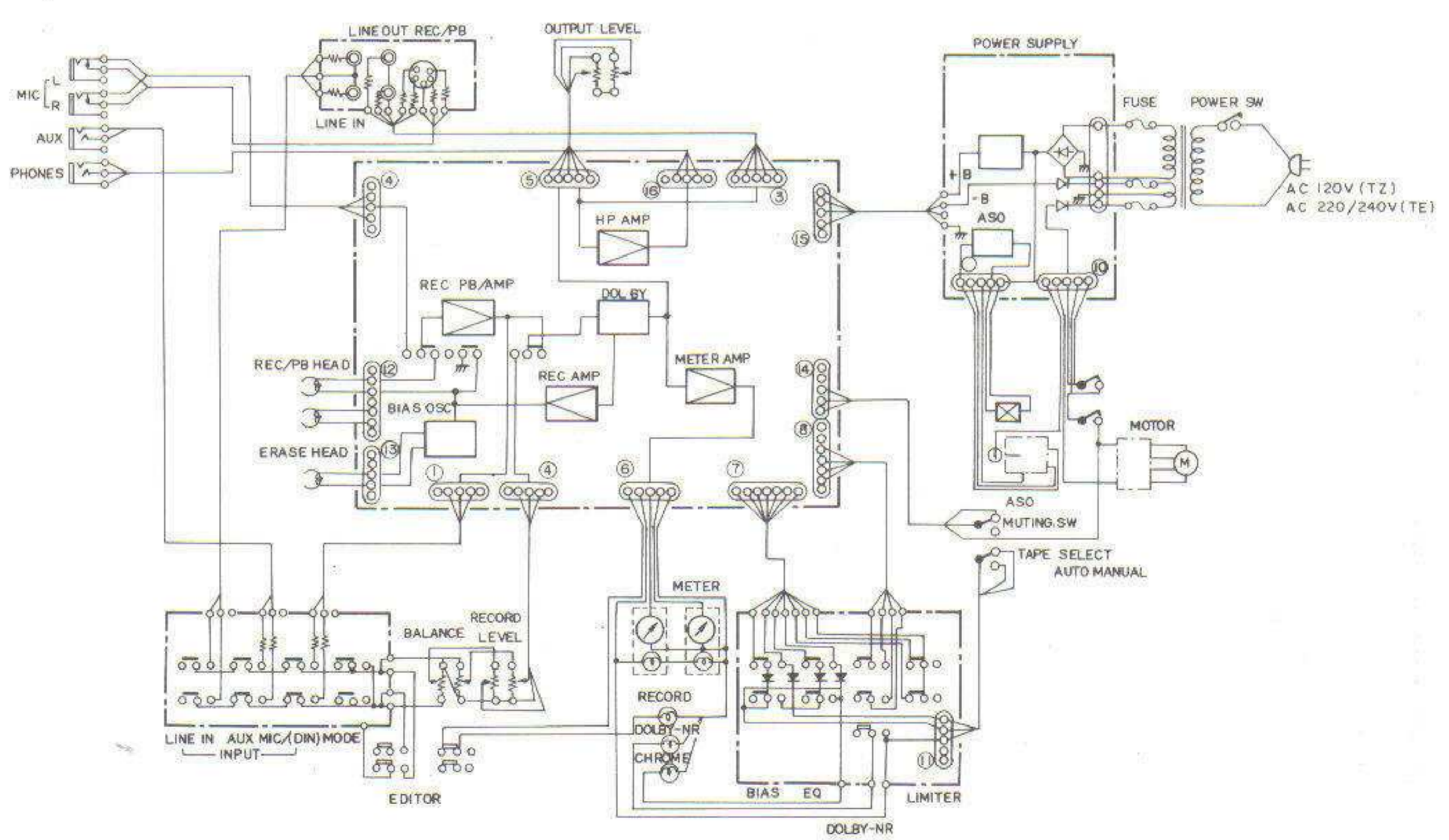

Figure 8.

ADJUSTMENT PROCEDURE

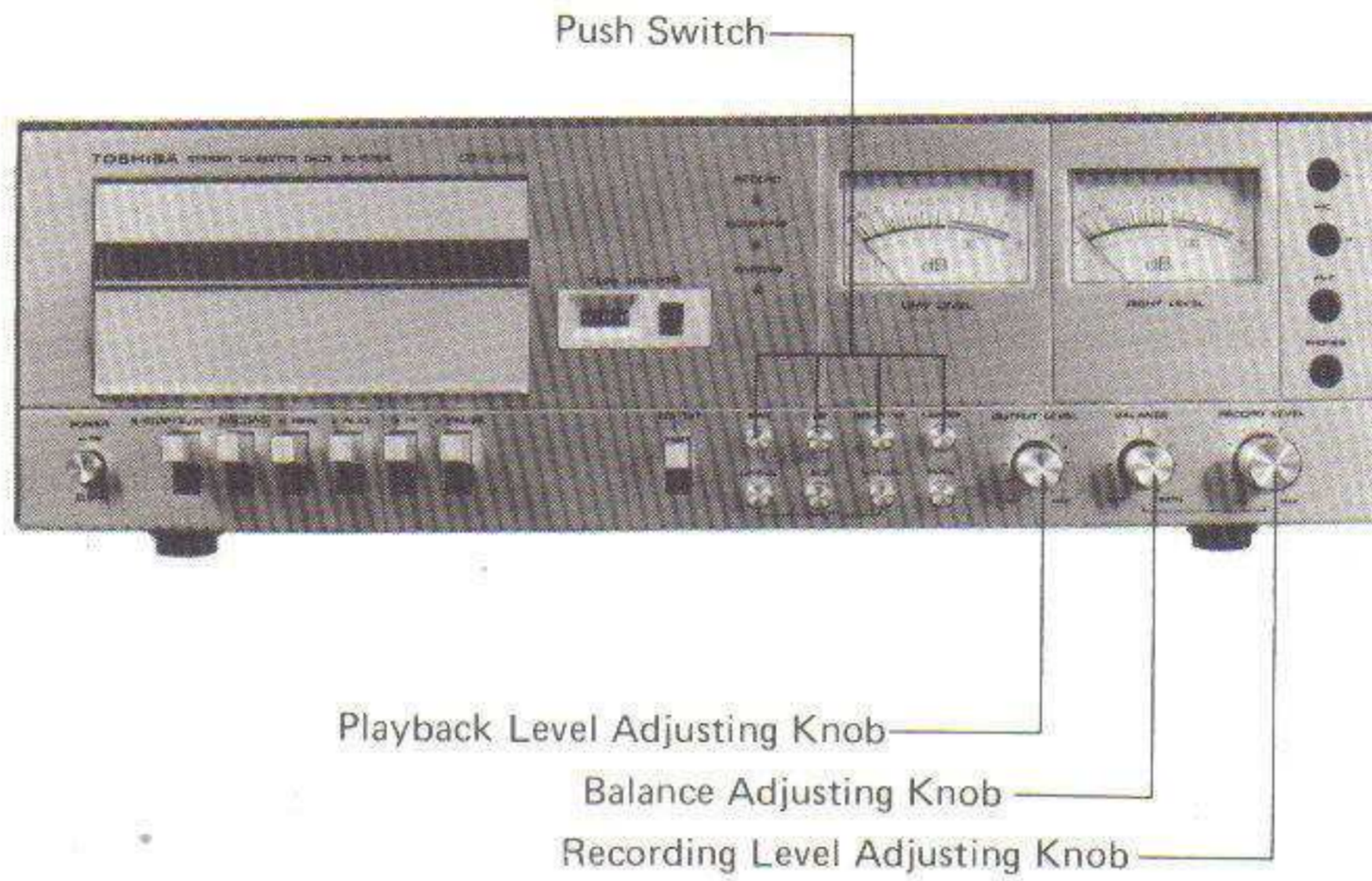

Figure 9.

Main Amplifier P.C. Board.

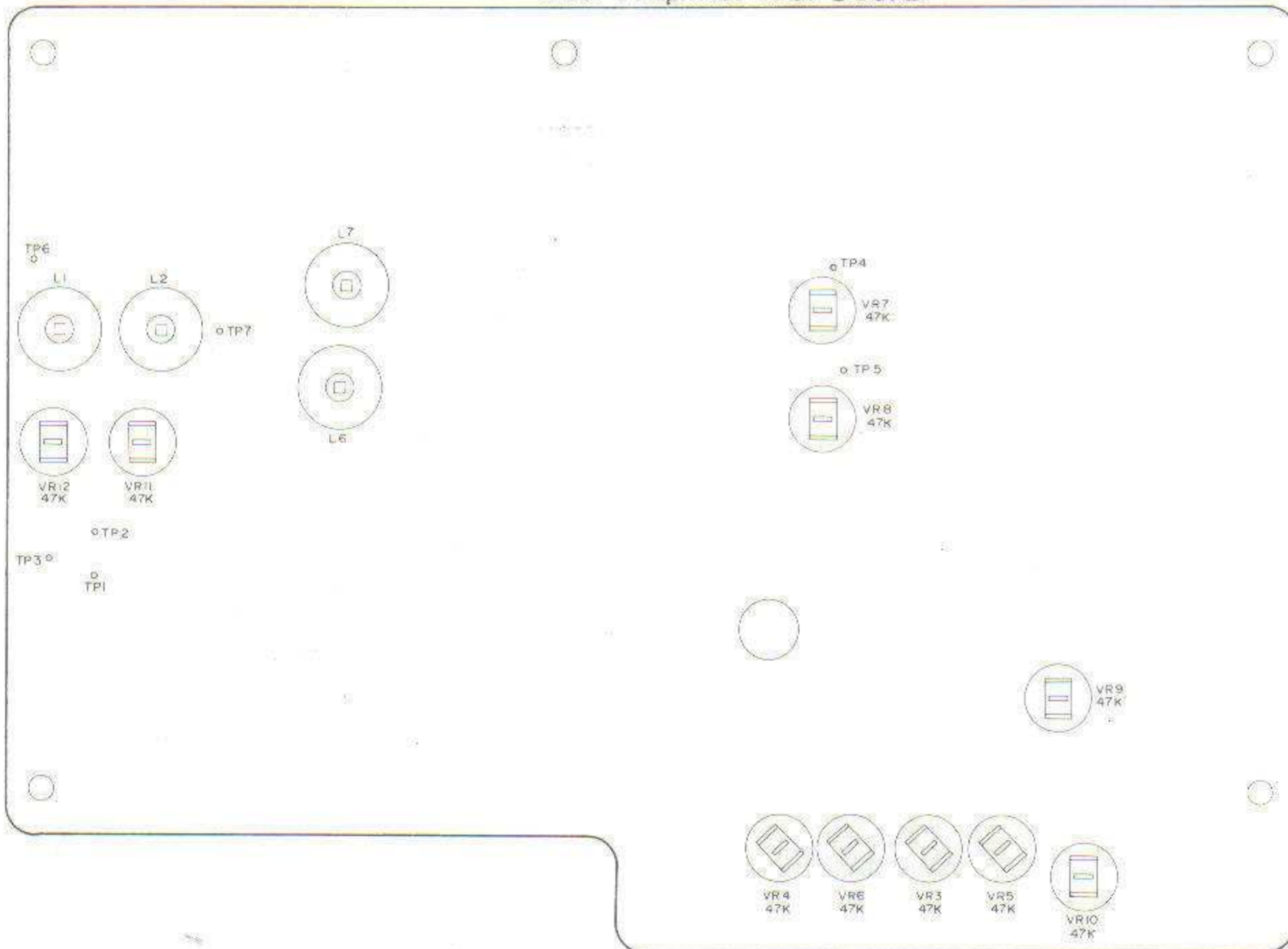

Figure 10. Sections for Adjustment

RECORD/PLAYBACK HEAD ADJUSTMENT

1. Connect the VTVM across the LINE OUT Jacks (Left and Right channels).
2. Turn the Playback Output Level Adjusting Knob to the maximum position and turn all push switches off.
3. Playback the test tape (MTT-114, 10kHz) and adjust the azimuth adjusting screw so that the VTVM indicates the maximum position.

CAUTION: When L and R channels are measured at the same time, difference should be under 2dB in the maximum position.

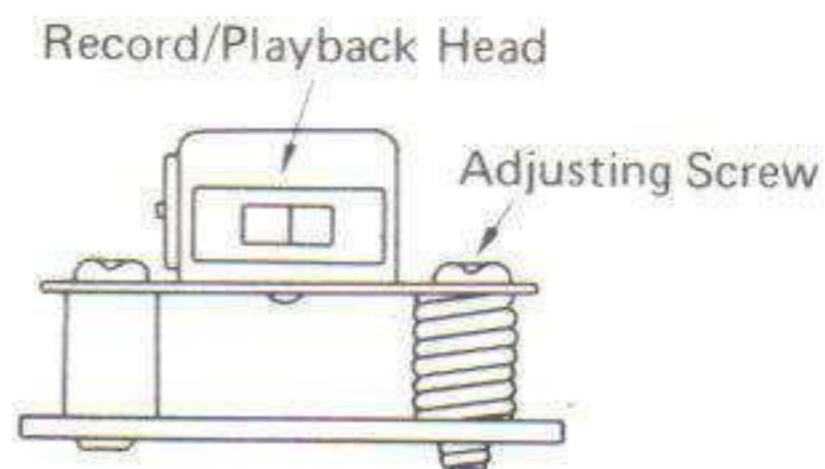

Figure 11.

PLAYBACK SENSITIVITY ADJUSTMENT

1. Connect the VTVM across the test points (TP4 and 5).
2. Set the Playback Output Level Adjusting Knob to the maximum position and turn all push switches off.
3. Playback the test tape (MTT-150, 400Hz) and adjust the variable resistors (VR4 and 6) so that the VTVM indicates 580mV.

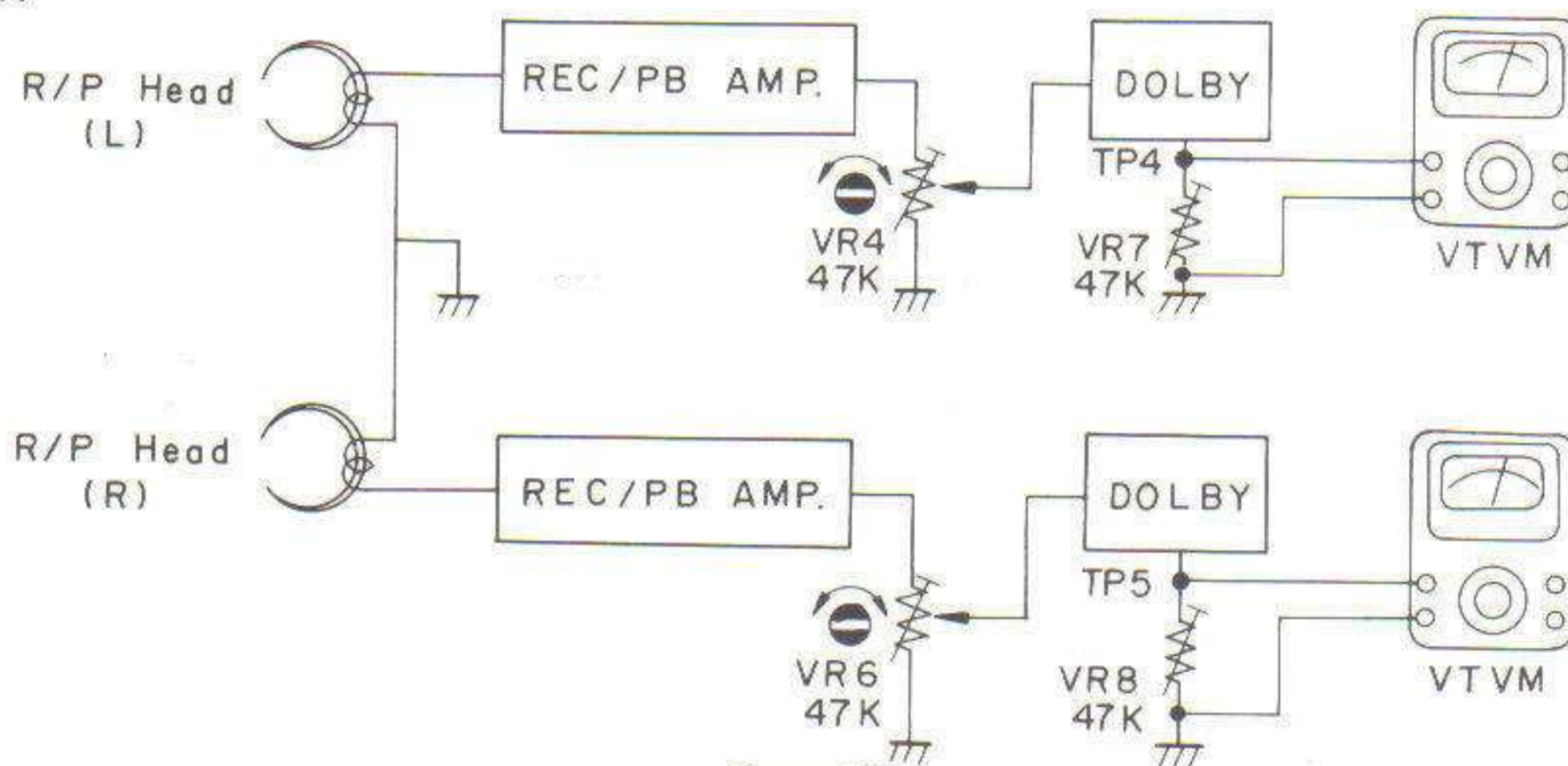

Figure 12.

LEVEL METER ADJUSTMENT

1. Connect the VTVM across the test points (TP4 and 5).
2. Playback the test tape (MTT - 150, 400Hz) and make certain the VTVM indicates 580mV.
3. Adjust the variable resistors (VR9 and 10) so that the Level meter indicates +3dB.

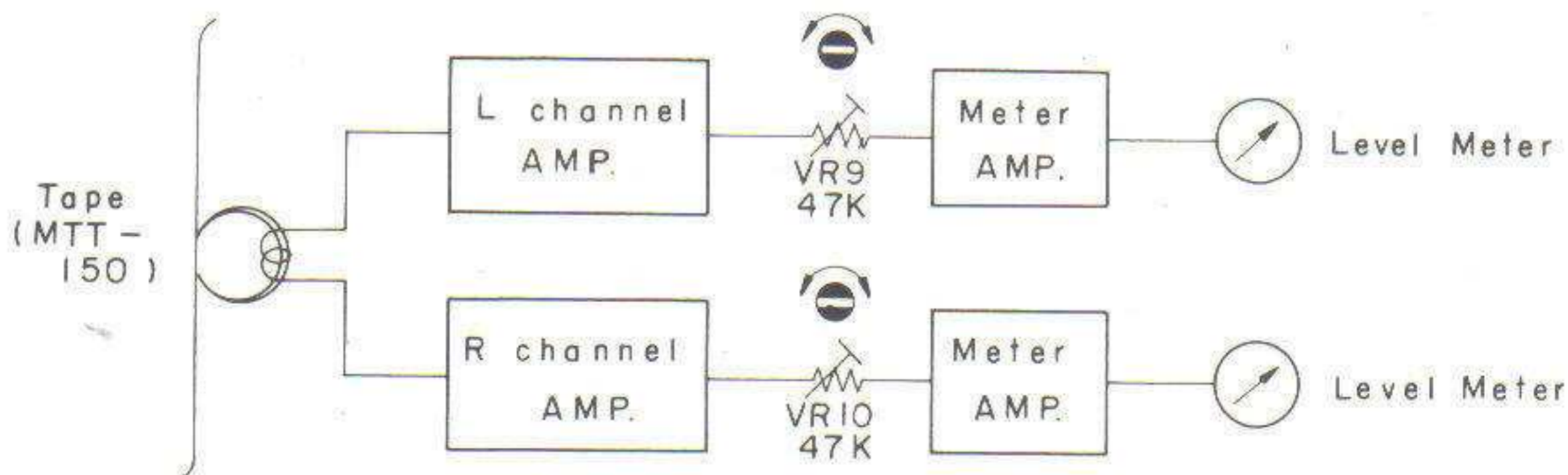

Figure 13.

RECORD INPUT SENSITIVITY ADJUSTMENT

1. Put into the test tape (MTT - 502, blank).
2. Connect the VTVM across the LINE OUT Jacks (Left and Right channels).
3. Set the Recording Level Adjusting Knob to the maximum position and the Balance Adjusting Knob to the middle of LEFT and RIGHT.
4. Apply the signal (20dB/V, 1kHz) to the LINE IN Jack and press RECORD and PLAY Levers. (In case of TE, apply the signal (0.47mV, 333Hz) to DIN Connector and press RECORD and PLAY Levers.)
5. Adjust the variable resistors (VR3 and 5) so that the Level Meter indicates 0dB. (In case of TE, adjust the variable resistors so that the Level Meter indicates +4dB.)

CAUTION: Make certain the output voltage at the LINE OUT is $410\text{mV} \pm 35\text{mV}$. (In case of TE, make certain the output voltage at the LINE OUT is $600\text{mV} \pm 35\text{mV}$.)

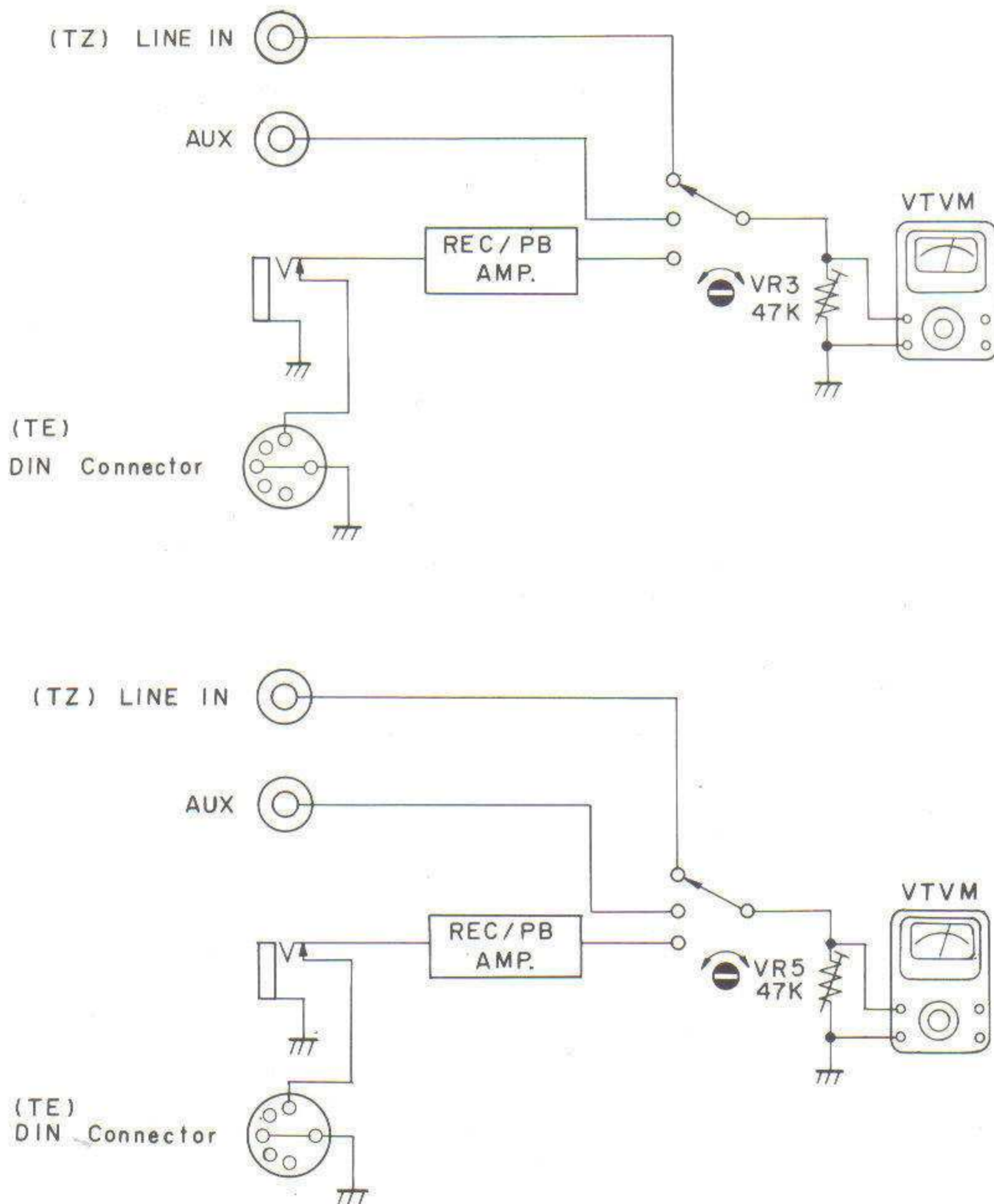

Figure 14.

BIAS LEAK ADJUSTMENT

1. Insert the test tape (MTT - 502, blank).
2. Connect the VTVM across the test points (TP6 and 7).
3. Turn all push switches off and press RECORD and PLAY Levers.
4. Adjust the trap coils (L1 and 2) so that the VTVM indicates the minimum position.

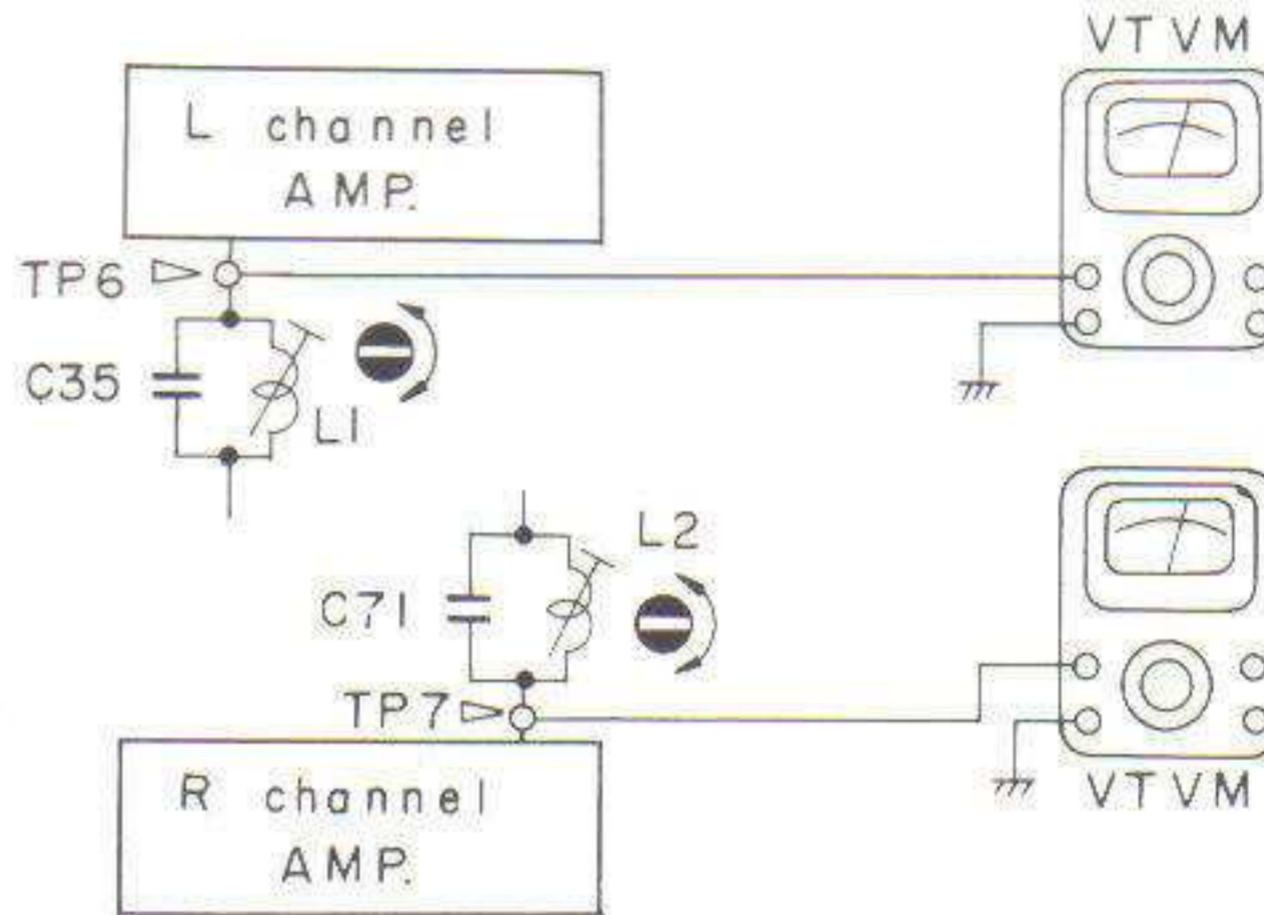

Figure 15.

BIAS CURRENT ADJUSTMENT

1. Insert the test tape (MTT - 502, blank).
2. Connect the VTVM across the test points (TP1 and 2) and the Ground (TP3).
3. Turn all push switches off and press RECORD and PLAY Levers.
4. Adjust the variable resistors (VR11 and 12) so that the VTVM indicates 5.5mV.

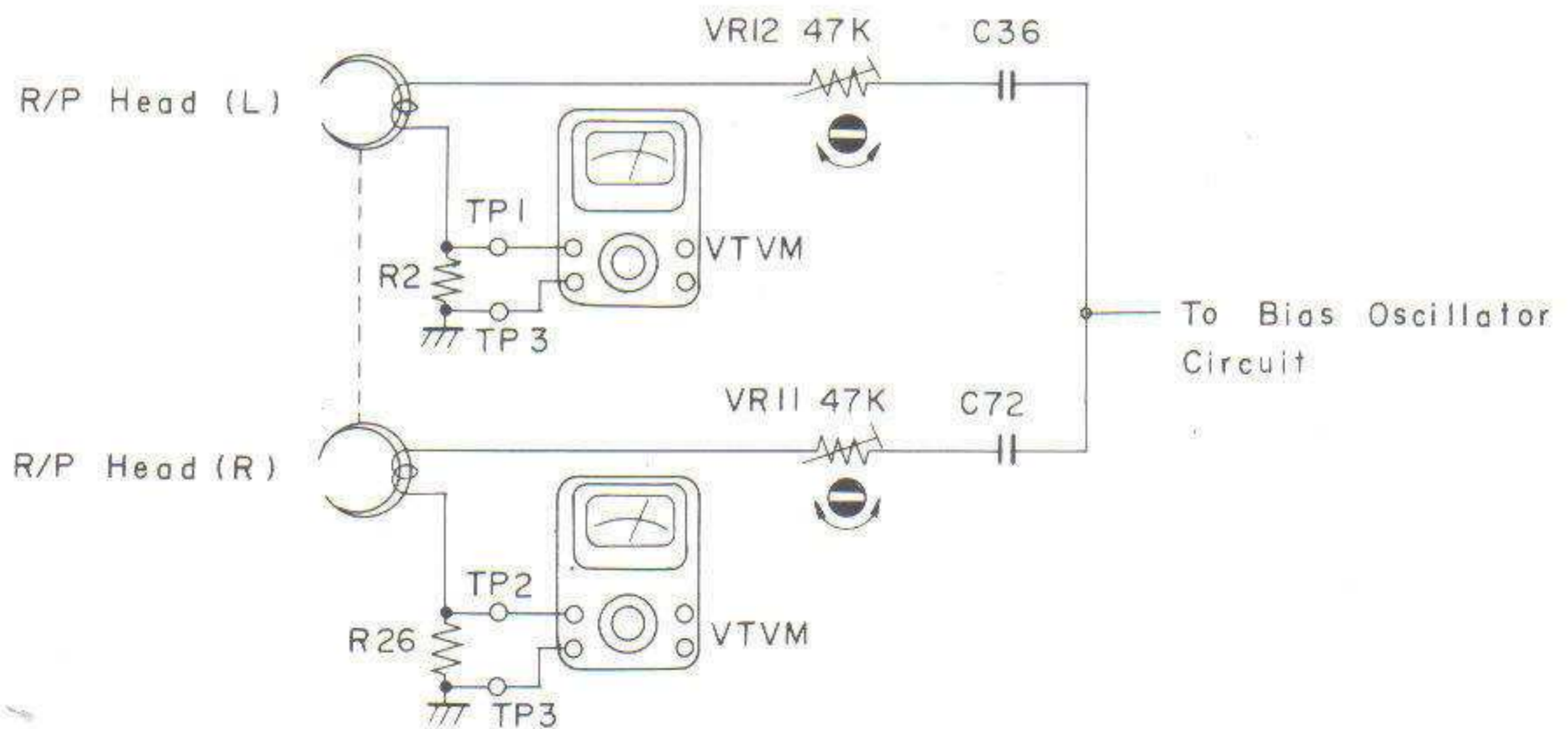

Figure 16.

RECORD/PLAYBACK LEVEL ADJUSTMENT

1. Insert the test tape (MTT - 502, blank).
2. Connect the VTVM across the LINE OUT Jack.
3. Set the Playback Output Level Adjusting Knob and Record Level Adjusting Knob to the maximum position and the Balance Adjusting Knob to the middle of LEFT and RIGHT.
4. Turn the push switch, LINE IN, on alone and the others off. (In case of TE, turn only the push switch, MIC/DIN, on.)
5. Apply the signal (-20dB, 1kHz) to the LINE IN Jack and record it. (In case of TE, apply the signal (0.47mV, 333Hz).)
6. Next, playback the test tape after rewinding it.
7. Adjust the semi-fixed resistors (VR7 and 8) so that the VTVM indicates 0dB.
(In case of TE, adjust the semi-fixed resistors so that the VTVM indicates +4dB.)

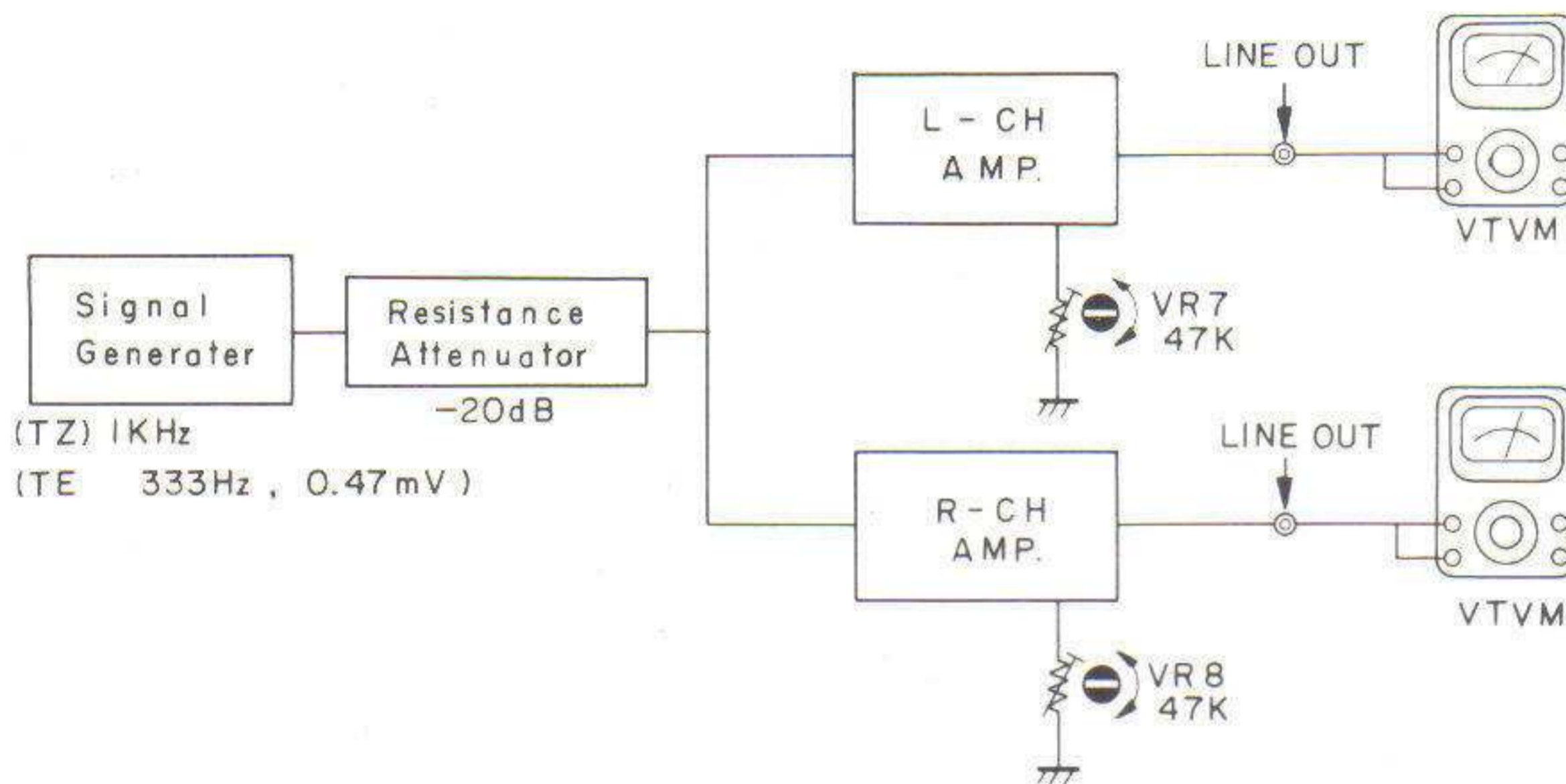

Figure 17.

PRECAUTION (For TE)

Do not set the voltage selector as shown in the left-hand illustration. In case of resetting, make certain the voltage indicator is set to the arrow correctly. The purpose is that it prevents the power transformer and the set itself from being damaged or burnt up.

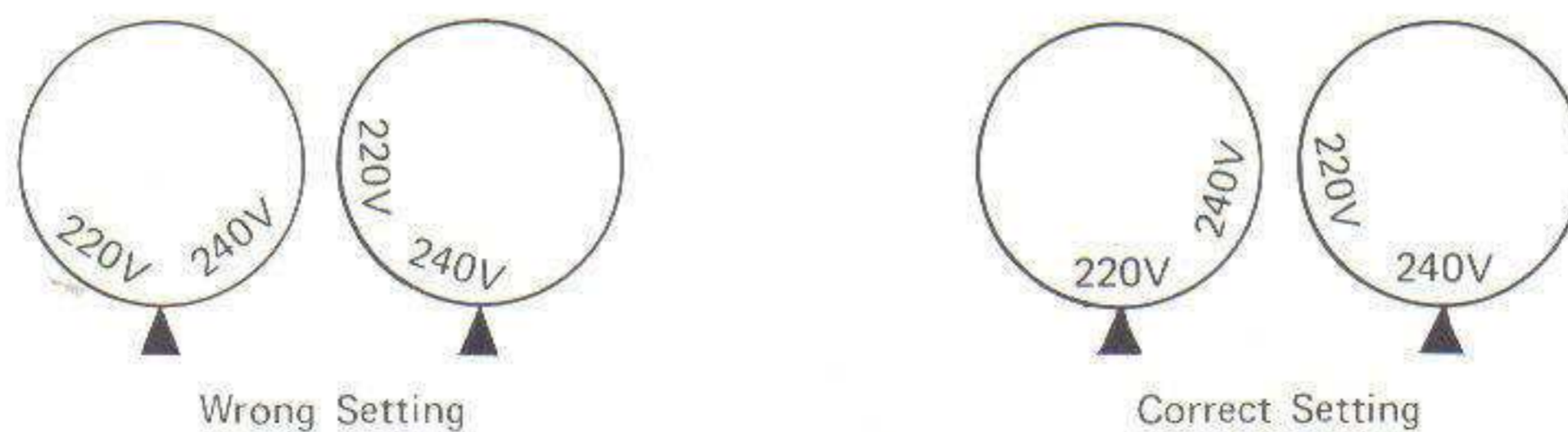

Figure 18.

ELECTRICAL PARTS LOCATIONS

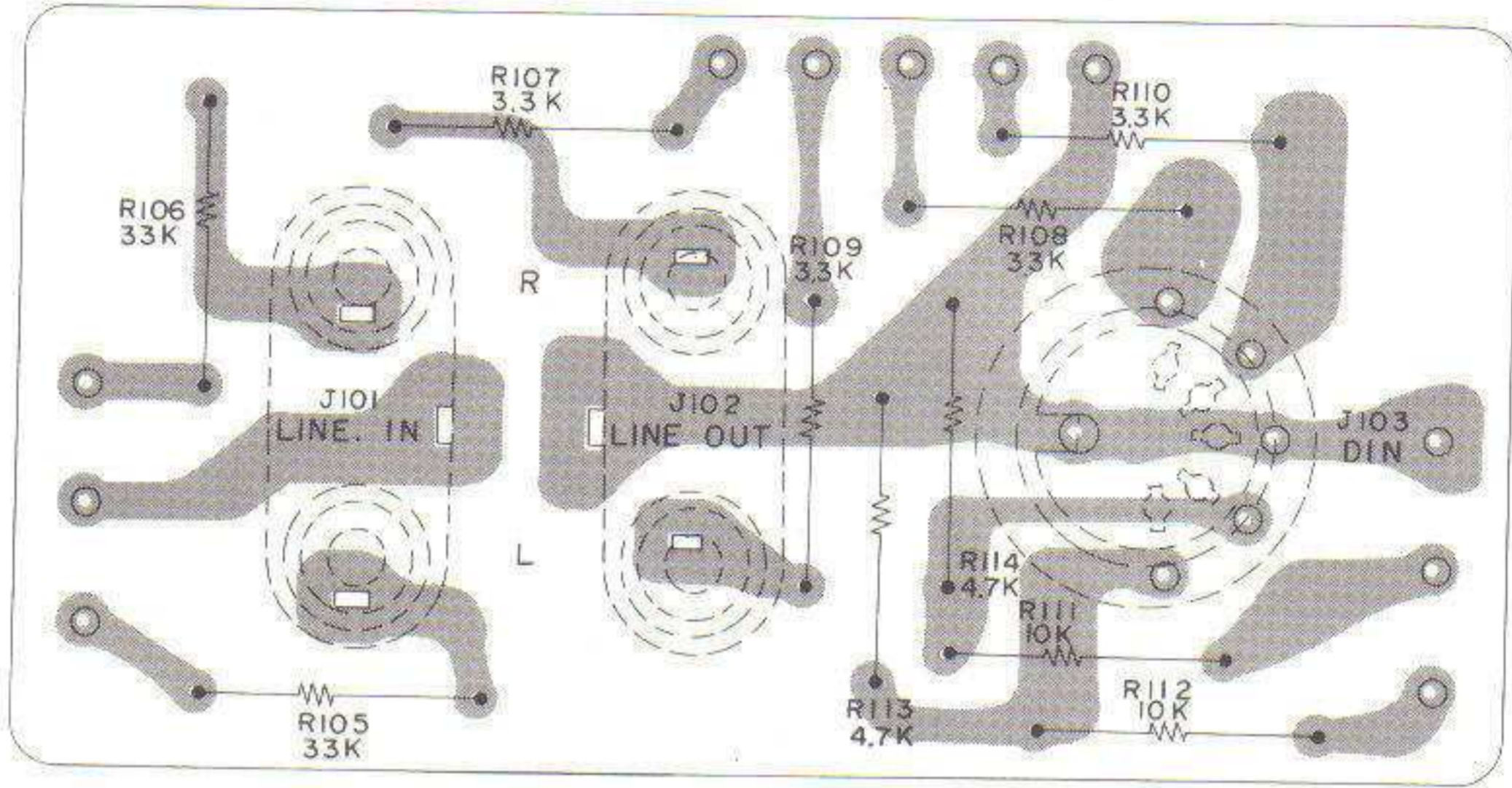

Figure 19. Bottom View of Jack P.C. Board (For TZ)

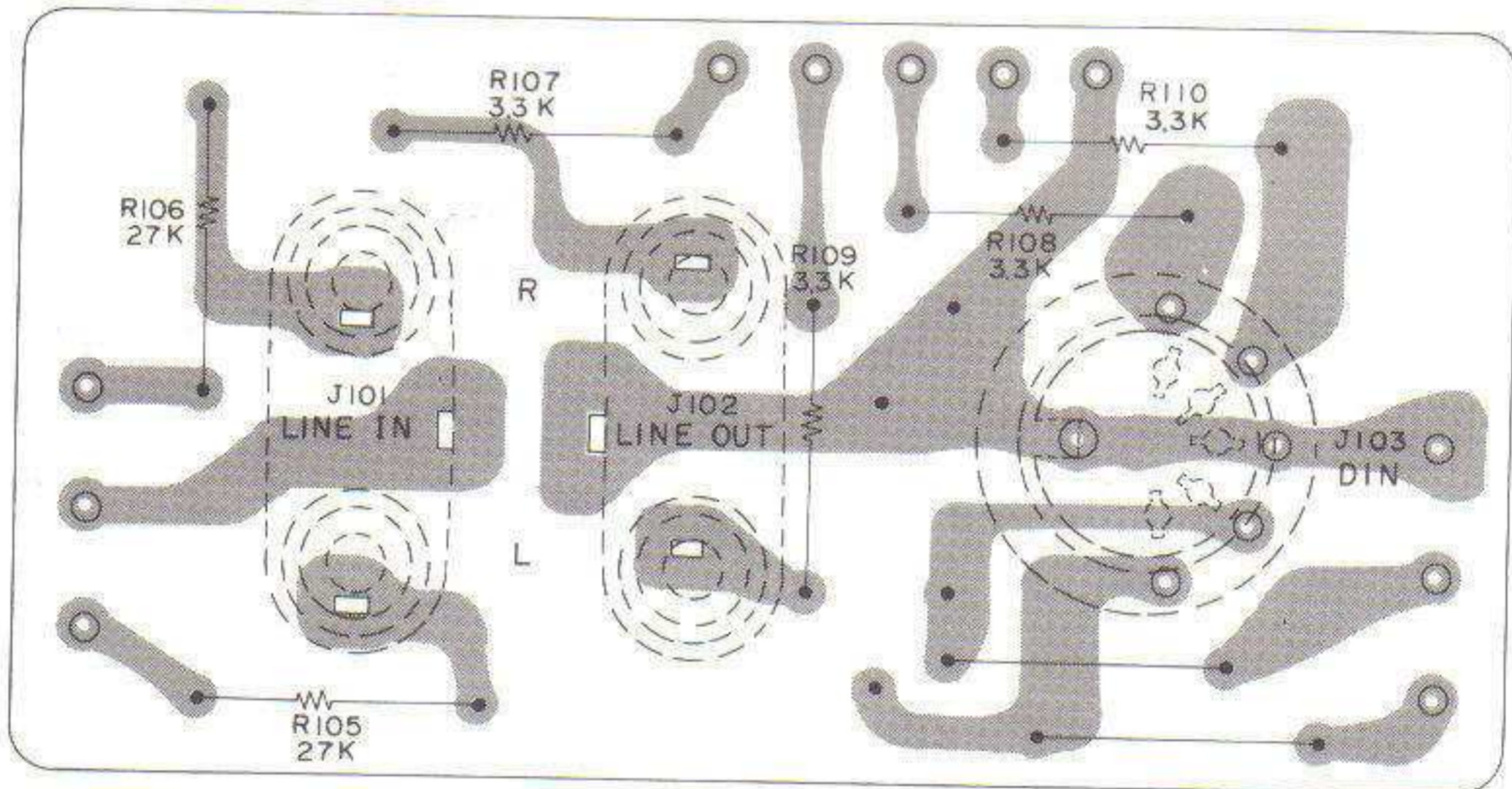

Figure 20. Bottom View of Jack P.C. Board (For TE)

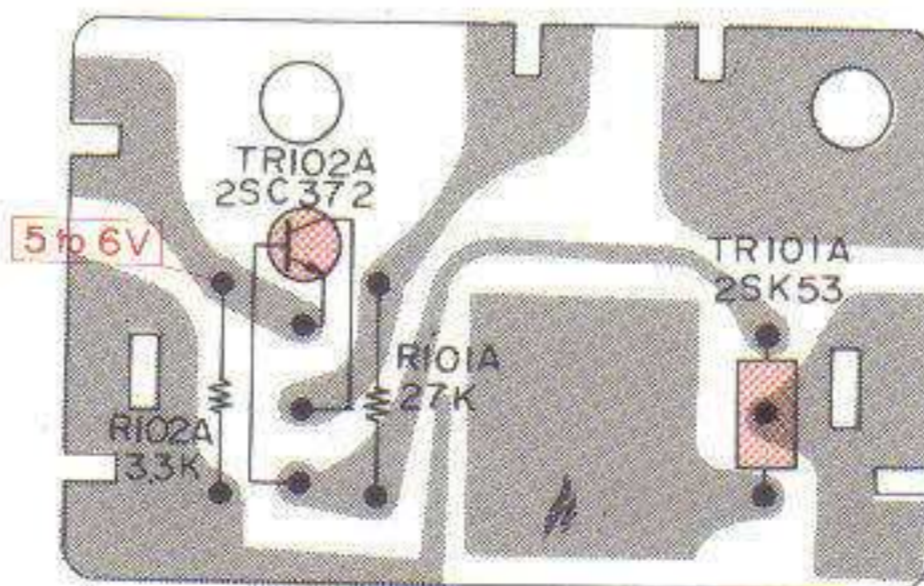

Figure 21. Bottom View of ASO P.C. Board

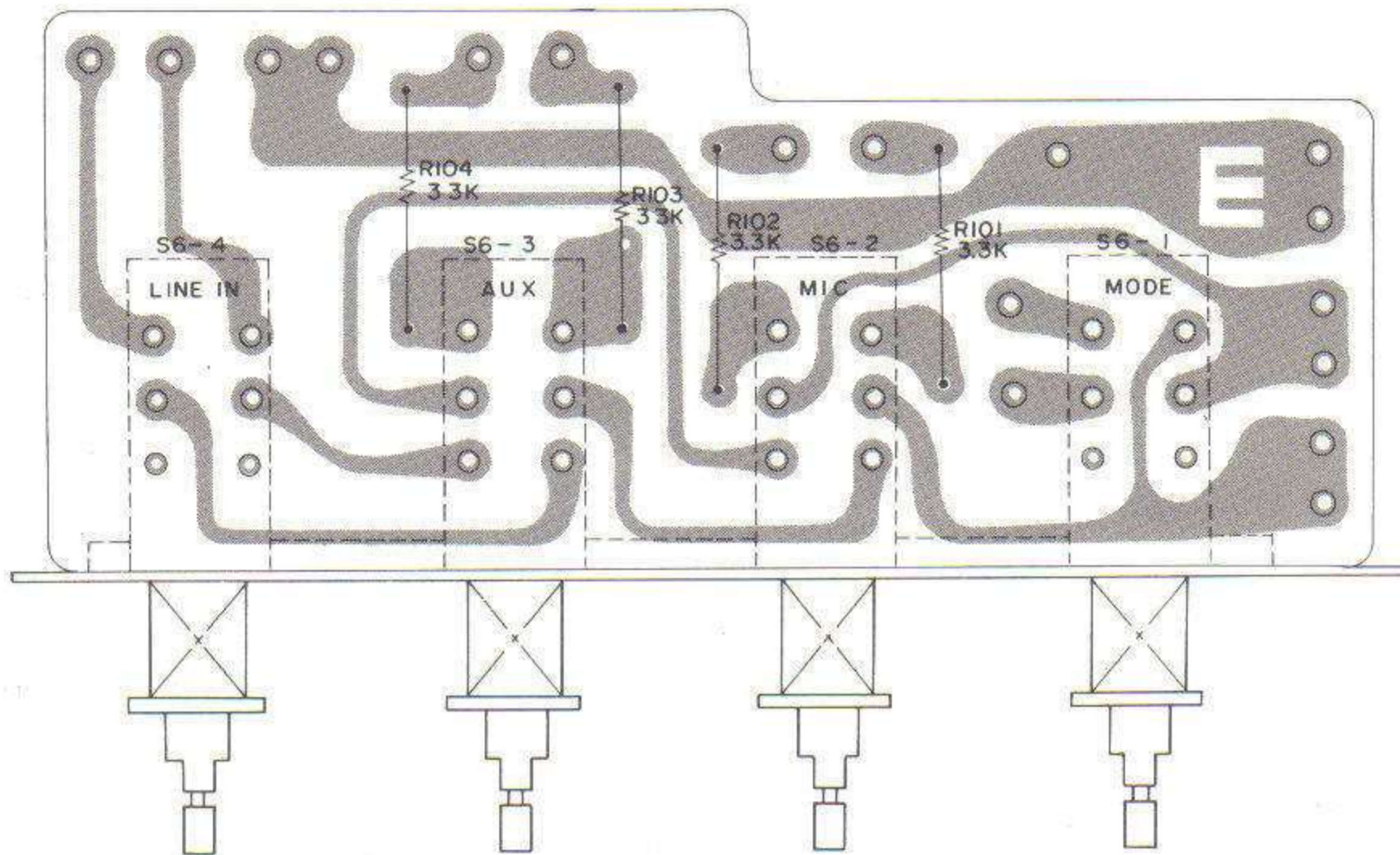

Figure 22. Bottom View of Push Switch P.C. Board (For TZ)

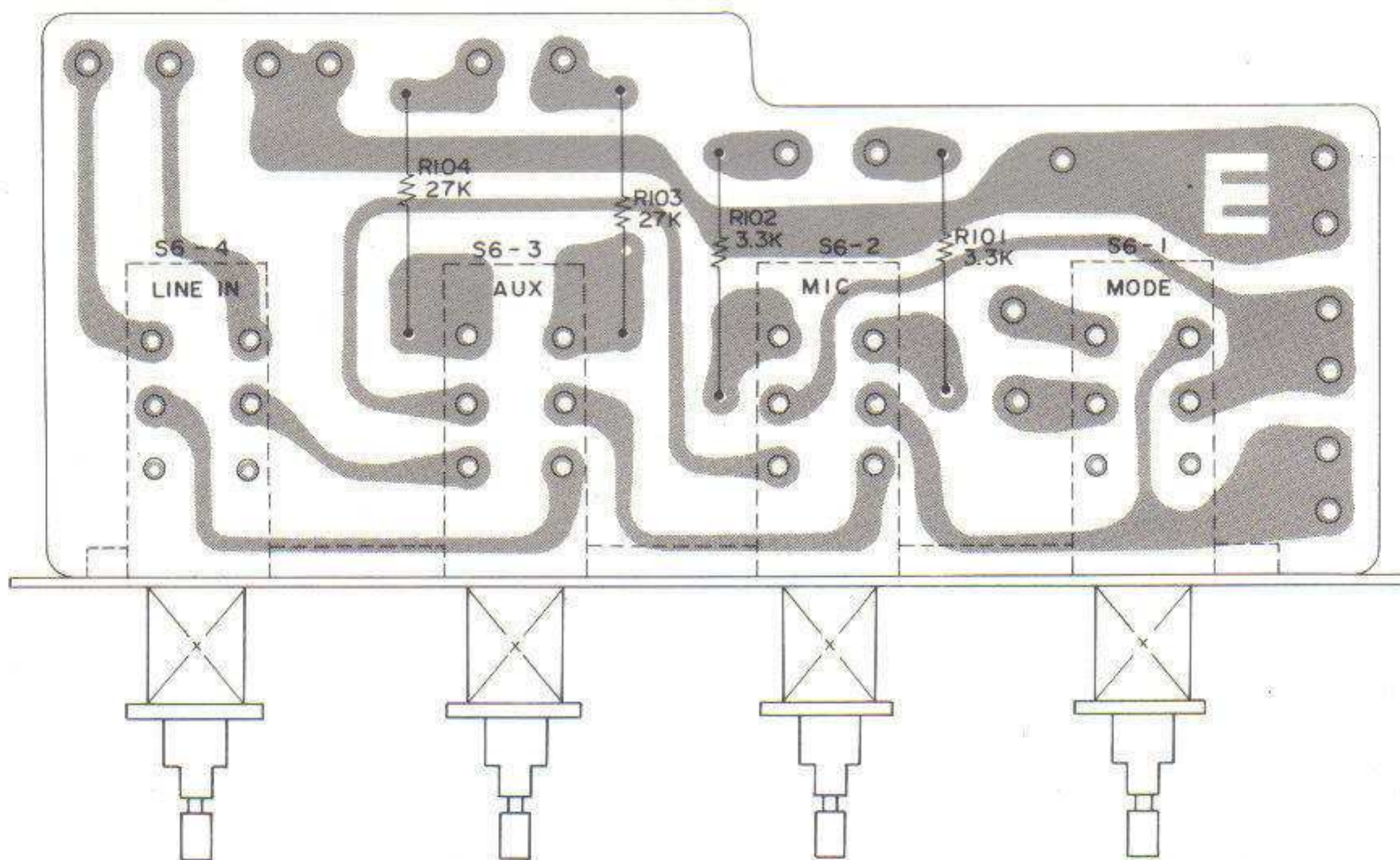

Figure 23. Bottom View of Push Switch P.C. Board (For TE)

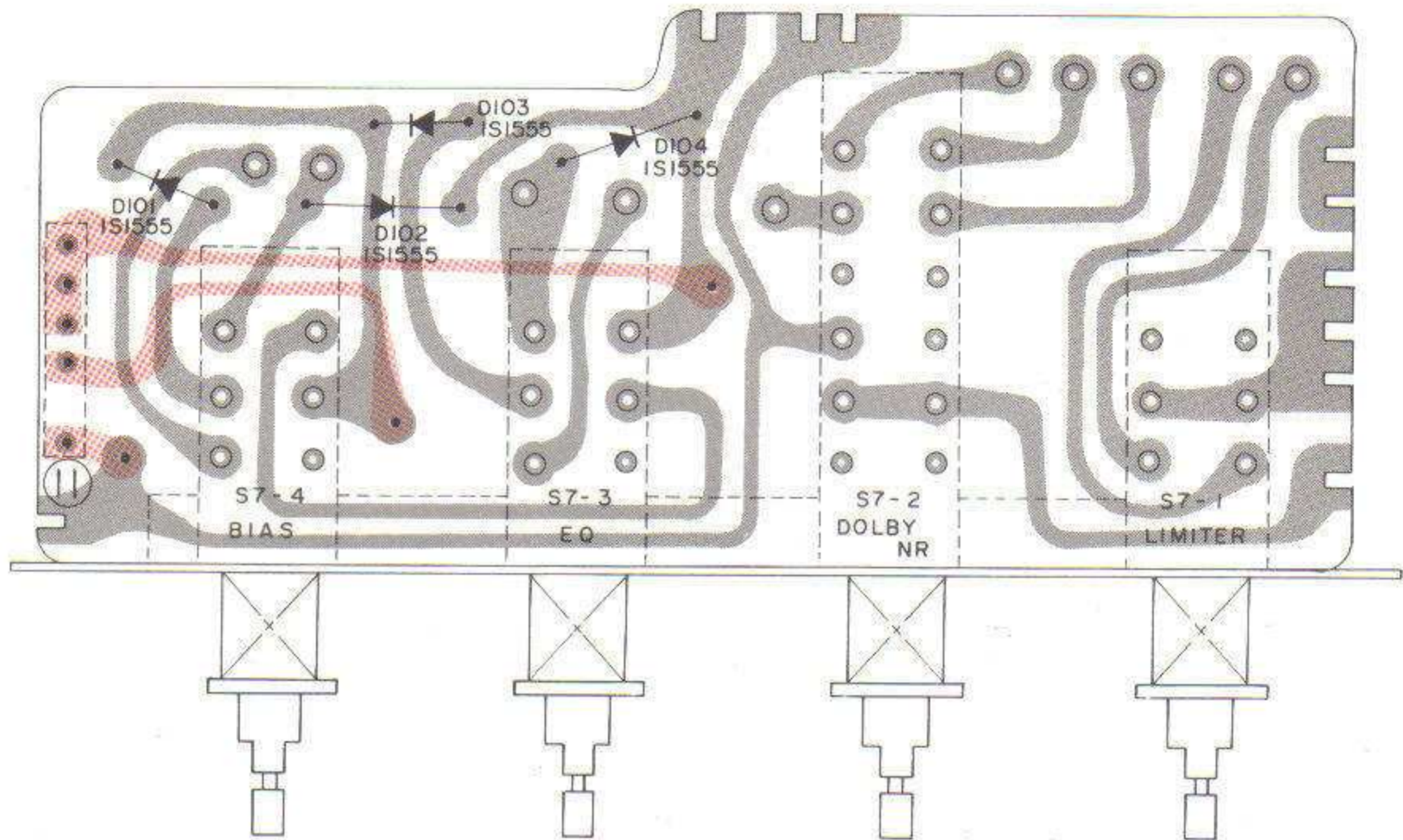

Figure 24. Bottom View of Push Switch P.C. Board

e 404/c 304 VA IN PERDITA, ANCHE SENZA CASSETTA VI SONO SCARICHE DI FONDO
 SU UNA DSI DUE CANALI O TUTTI E DUE
 DIFETTO TROVATO SULLA PIASTRA (PC 6030) CIRCUITO MOLTO SIMILE

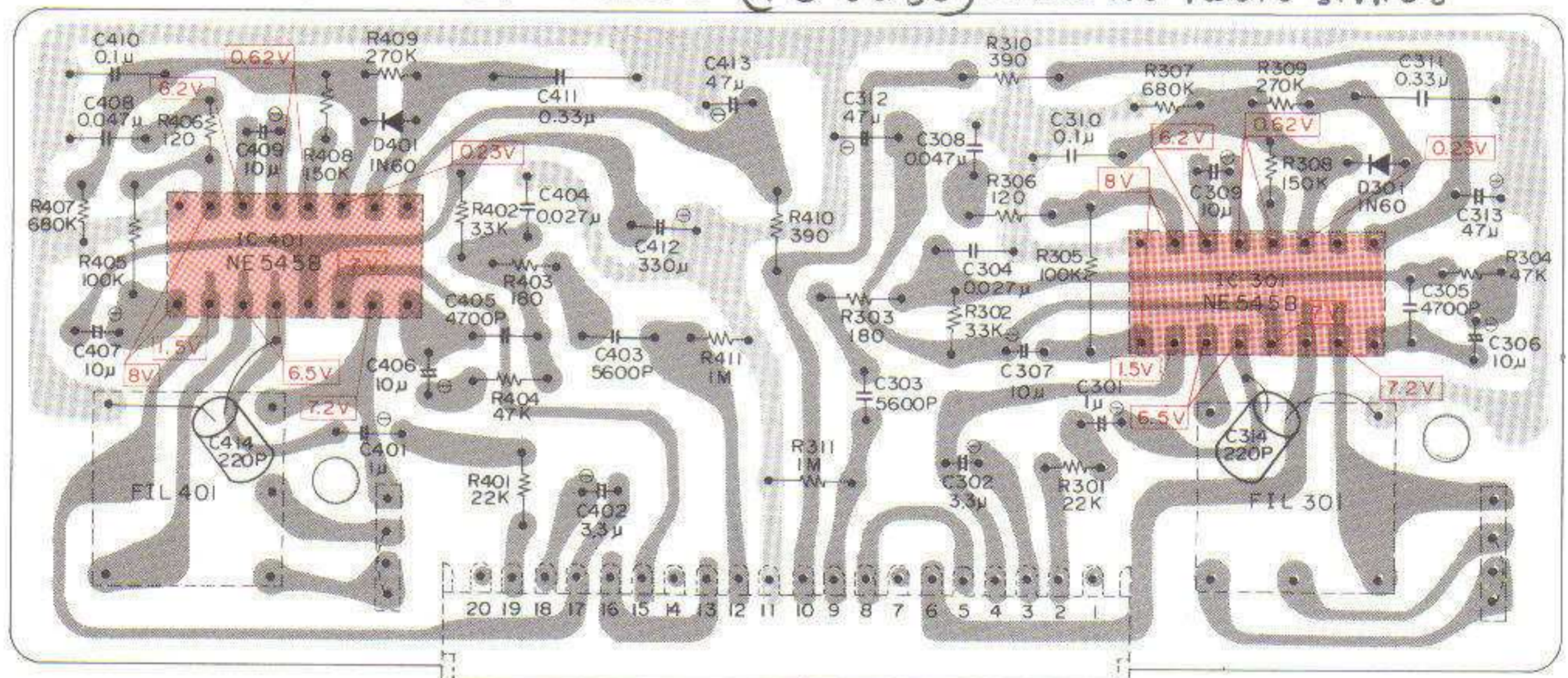

Figure 25. Bottom View of Dolby P.C. Board

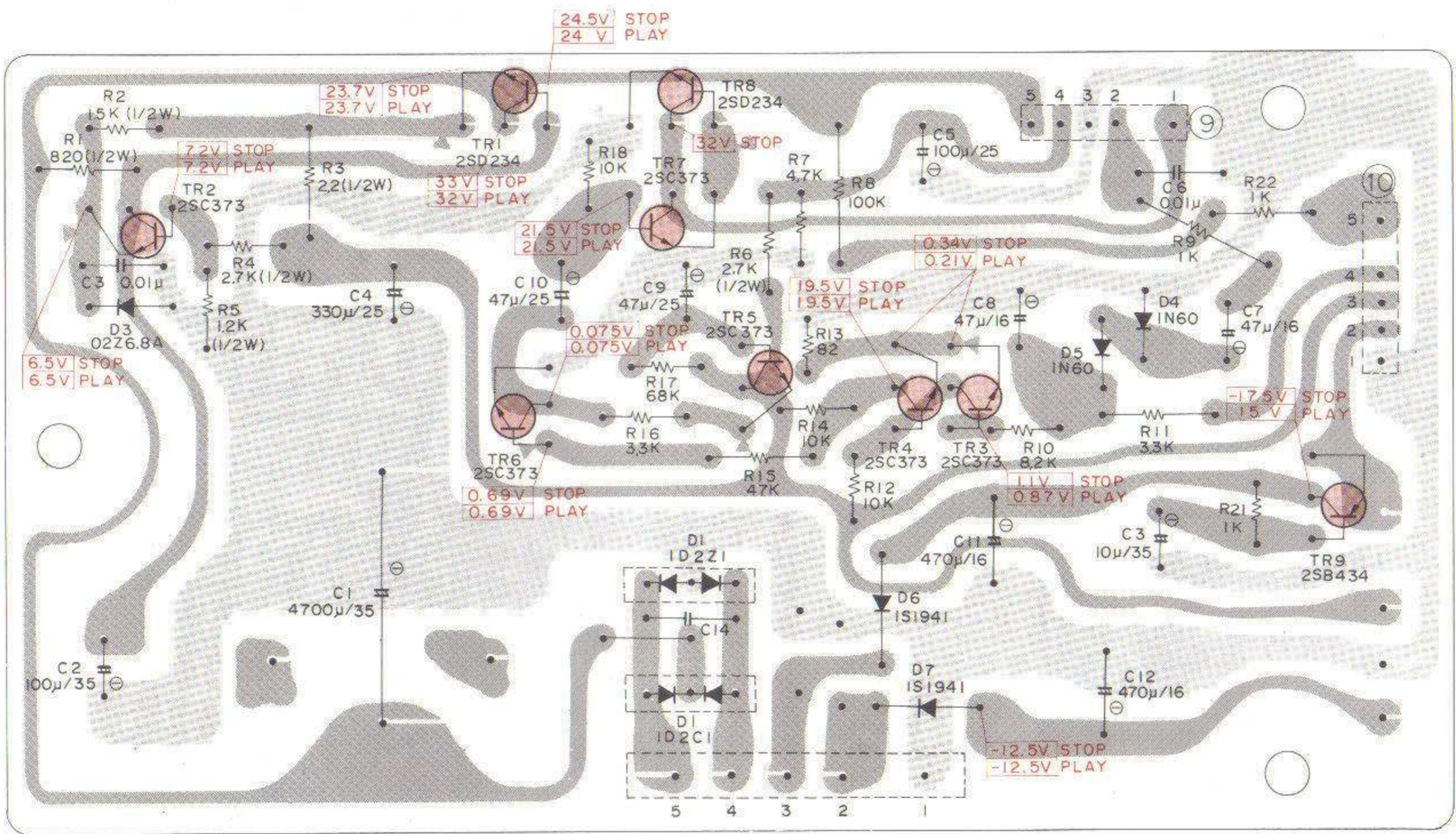
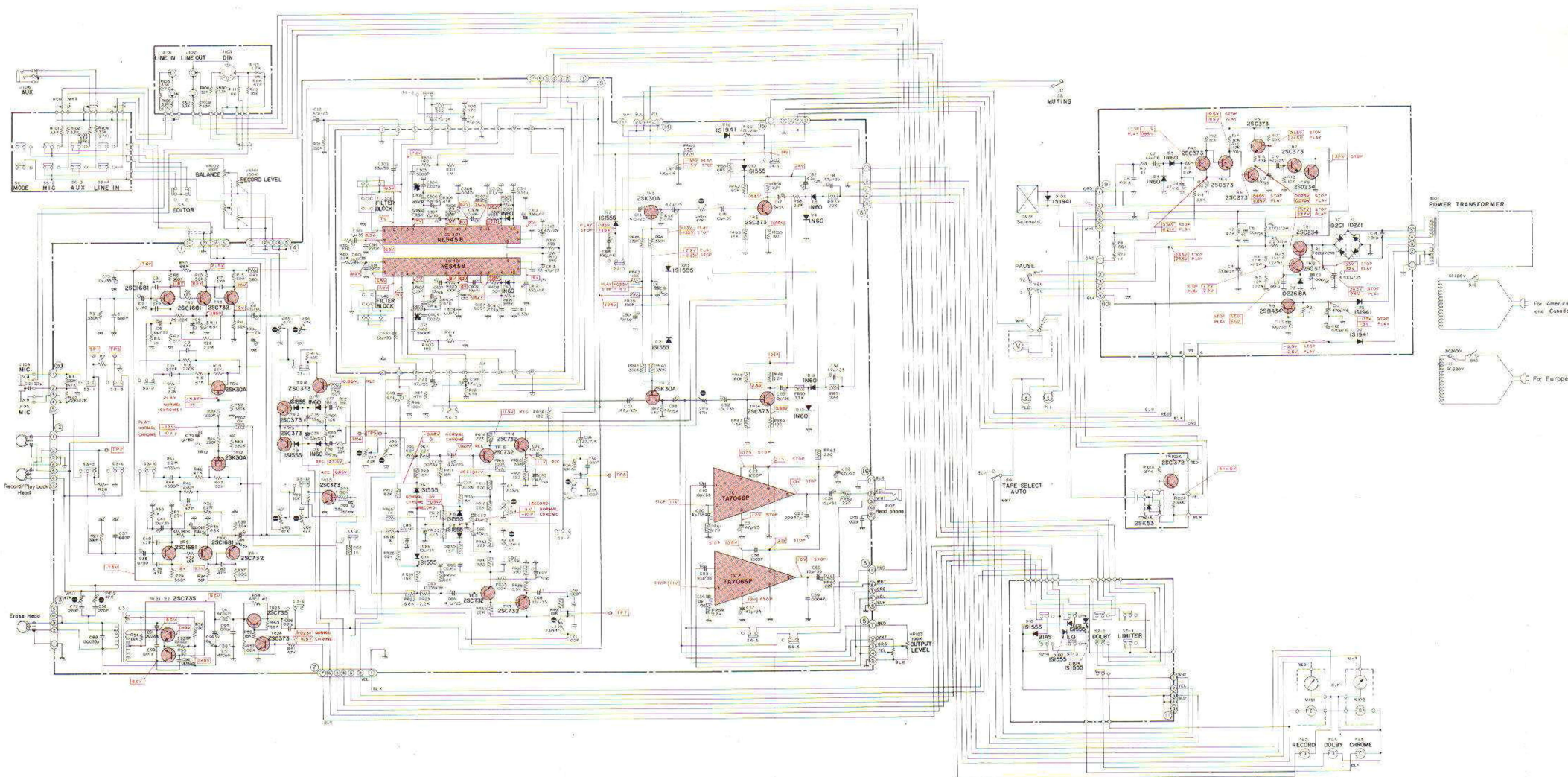

Figure 26. Bottom View of Power Supply P.C. Board



* SCARICHI IN FONDO C 304 o 404 IN PIRELLA

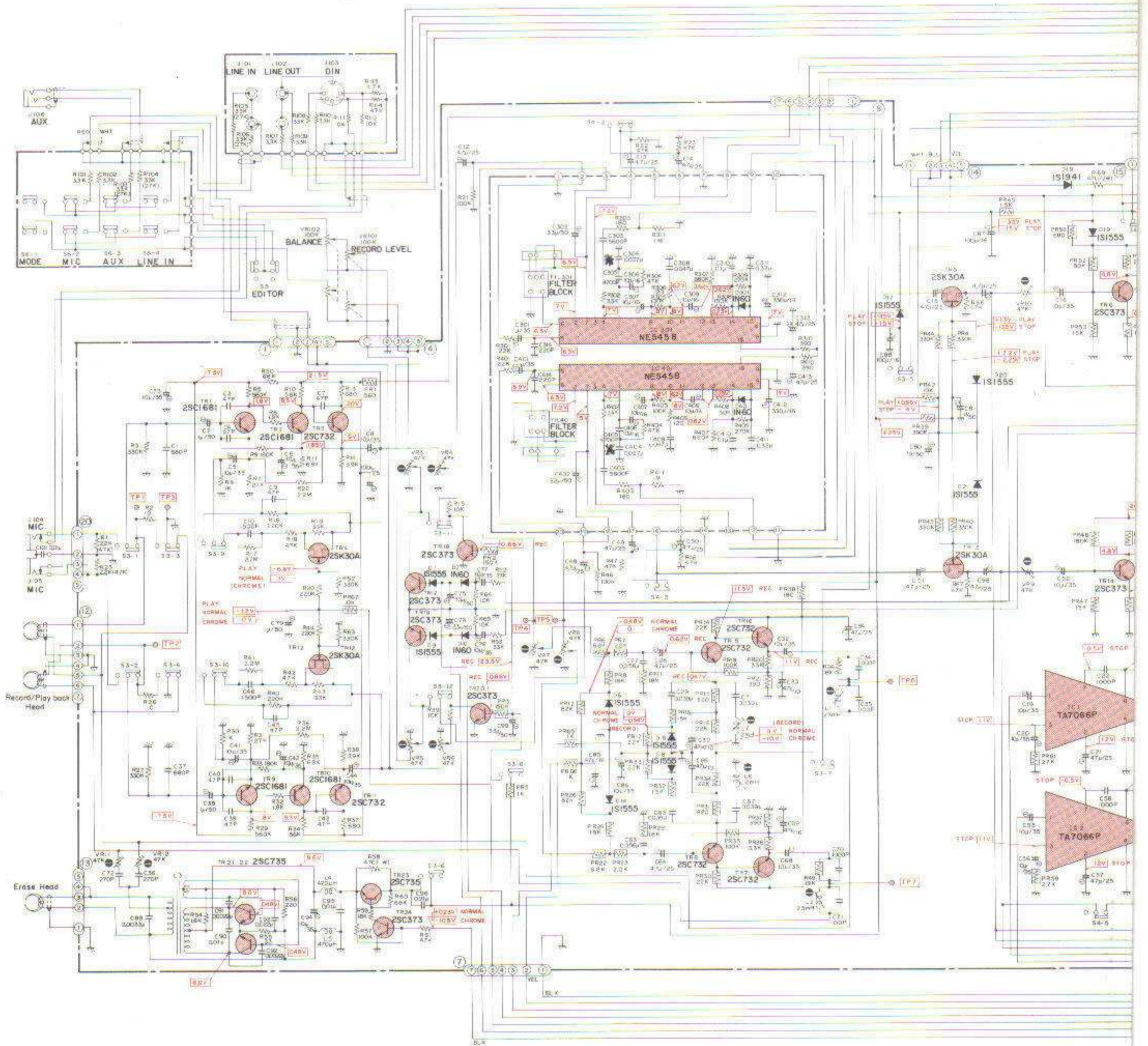

Figure 27. Sc

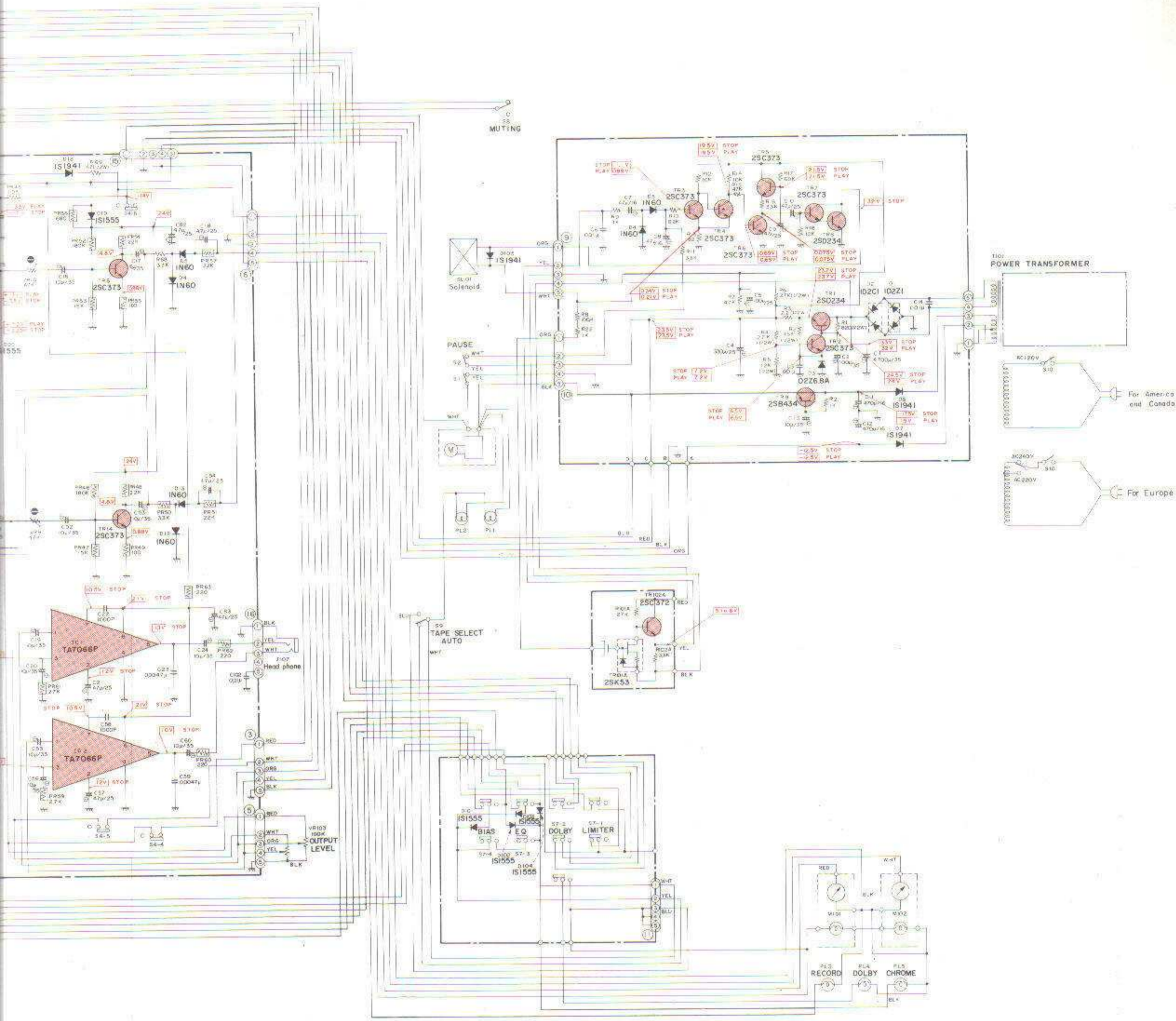

Figure 27. Schematic Diagram

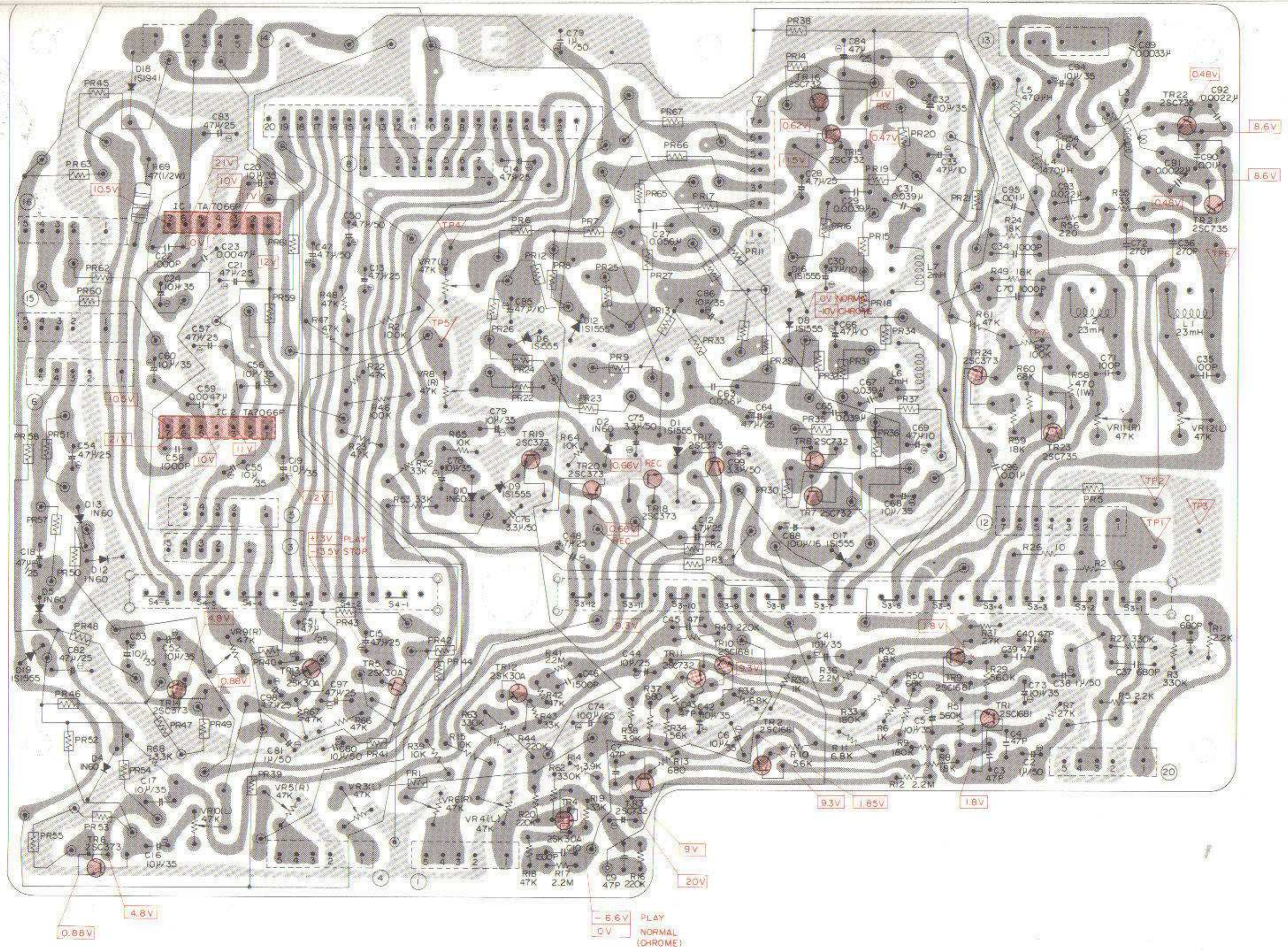

Figure 28. Bottom View of Main Amplifier P.C. Board

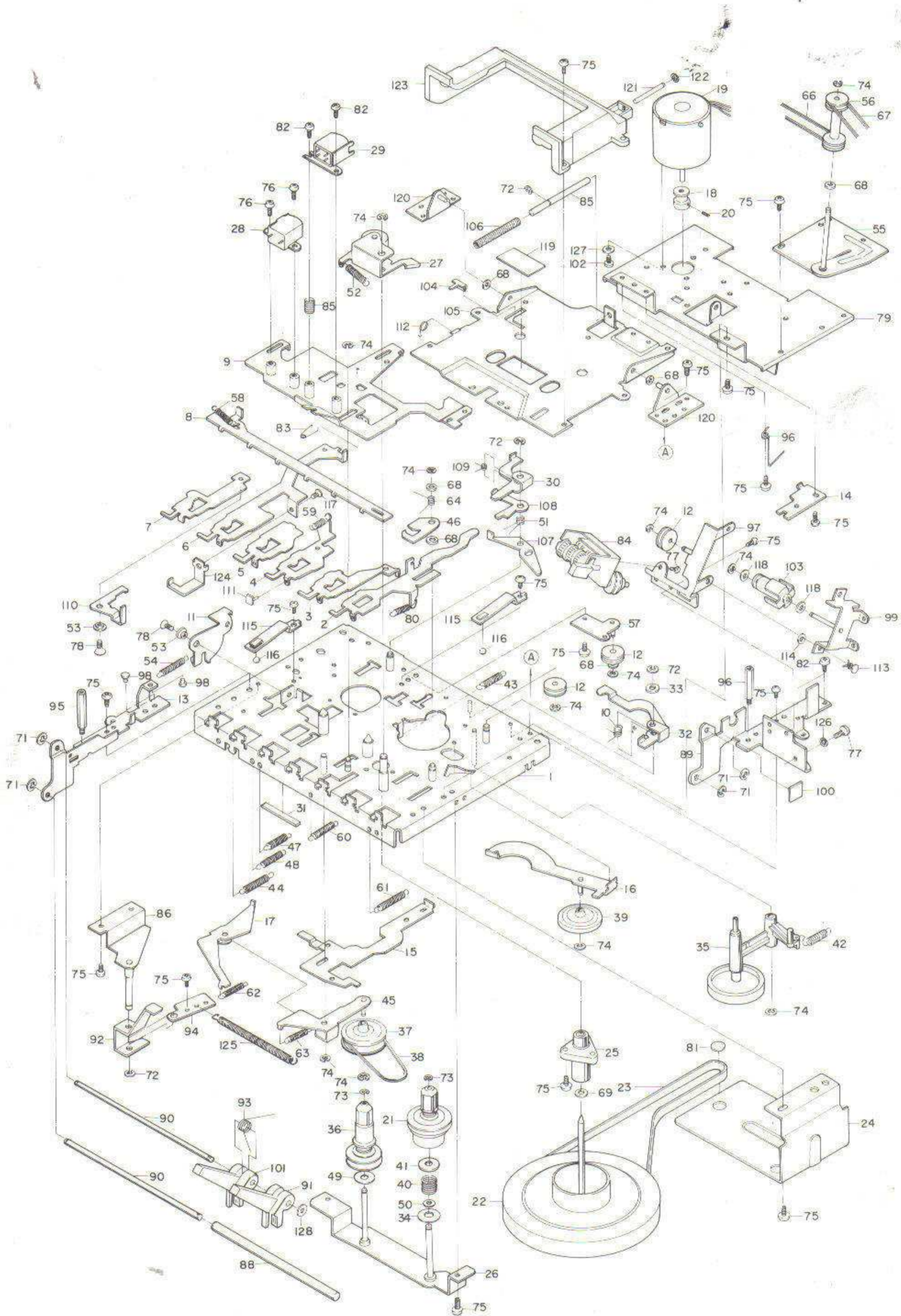

Figure 29. Exploded View (Mechanism)

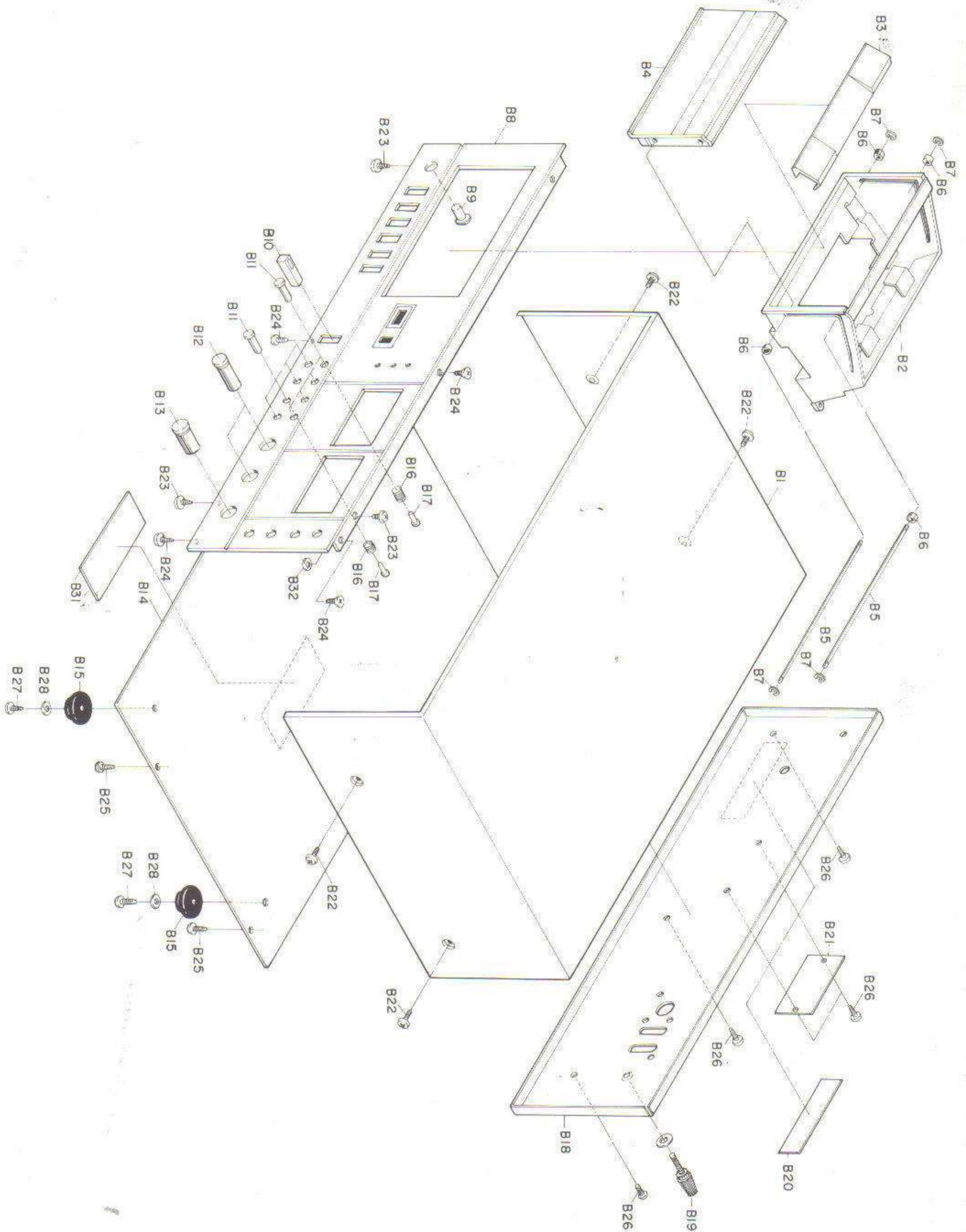

Figure 30. Exploded View (Cabinet)

PARTS LIST

Symbol No.	Part No.	Description
TRANSISTORS, DIODES AND IC'S		
Main Amplifier Circuit		
TR1,9		Transistor, 2SC1681-BL
TR2,10		Transistor, 2SC1681-BL
TR3,11		Transistor, 2SC732-BL
TR4,12		Transistor, 2SK30A-O-R/O
TR5,13		Transistor, 2SK30A-O-R/O
TR6,14		Transistor, 2SC373
TR7,16		Transistor, 2SC732-BL
TR8,15		Transistor, 2SC732-BL
TR17,19		Transistor, 2SC373
TR18,20		Transistor, 2SC373
TR21,22		Transistor, 2SC735-Y
TR23		Transistor, 2SC735-Y
TR24		Transistor, 2SC373
Power Supply Circuit		
TR1		Transistor, 2SD234 O
TR2		Transistor, 2SC373
TR3		Transistor, 2SC373
TR4		Transistor, 2SC373
TR5		Transistor, 2SC373
TR6		Transistor, 2SC373
TR7		Transistor, 2SC373
TR8		Transistor, 2SD234-O
TR9		Transistor, 2SD434-O
ASO Circuit		
TR101A		Transistor, 2SK53-V-1
TR102A		Transistor, 2SC372
Main Amplifier Circuit		
D1,9		Diode, 1S1555
D2,10		Diode, 1N60-FD1
D4,5		Diode, 1N60-FD1
D6,14		Diode, 1S1555
D8,16		Diode, 1S1555
D12,13		Diode, 1N60-FD1
D17		Diode, 1S1555
D18		Diode, 1S1941
D19		Diode, 1S1555
D20,21		Diode, 1S1555
Power Supply Circuit		
D1		Diode, 1D2Z1
D2		Diode, 1D2C1
D3		Diode, 02Z6. 8A
D4,5		Diode, 1N60
D6,7		Diode, 1S1941

Symbol No.	Part No.	Description
Push Switch Circuit		
D101,102, 103,104		Diode, 1S1555
Dolby Circuit		
D301,401		Diode, 1N60
Main Amplifier Circuit		
IC1,2		Integrated Circuit, TA7066P
Dolby Circuit		
IC301,401	22114299	Integrated Circuit, NE545B
ELECTRICAL PARTS		
T101	22223034	Transformer, Power (TZ)
	22223033	Transformer, Power (TE)
L1,2	22232143	Coil, Trap, 23mH
L3	22235146	Coil, Bias Oscillator
L4,5	22230106	Coil, Micro, 470mH
L6,7	22232107	Coil, Trap, 2mH
J101,102, 103	22163445	Jack Ass'y
J104,105	22163464	Jack, MIC
J106,107	22163463	Jack, AUX and PHONES
SL101	22147106	Solenoid
FIL301,401	22137752	Filter Block
M101,102	22104273	Level Meter
PL1,2,3, 4,5	22113322	Lamp
S1	22145985	Leaf Switch
S2	22146576	Leaf Switch
S3	22146765	Slide Switch
S4	22146709	Slide Switch
S5	22146744	Lever Switch
S6	22146719	Push Switch
S7	22146720	Push Switch
S8	22146731	Micro Switch
S9	22146731	Micro Switch
S10	22146990	Push Switch, Power (TZ)
	22146793	Push Switch, Power (TE)
S11	22146707	Switch, Voltage Select (TE)
	22176221	Power Supply Cord (TZ)
	22176286	Power Supply Cord (TE)
	22144287	Fuse, B501 - S (TE)
CAPACITORS		
G=±20%, J=±5%, K=±10%, M=±20%, P=-0 + 100%		
Main Amplifier Circuit		
C1,37	22382681	Polystyrene, 680pF, 50WV, K
C2,38	22440066	Electrolytic, 1mfd, 50WV

Symbol No.	Part No.	Description
C3,39	22362470	Ceramic, 47pF, 50WV, K
C4,40	22362470	Ceramic, 47pF, 50WV, K
C5,41	22447100	Electrolytic, 10mfd, 35WV
C6,42	22447100	Electrolytic, 10mfd, 35WV
C7,43	22362470	Ceramic, 47pF, 50WV, K
C8,44	22447100	Electrolytic, 10mfd, 35WV
C9,45	22362470	Ceramic, 47pF, 50WV, K
C10,46	22373152	Mylar, 1500pF, 50WV, K
C12,48	22446479	Electrolytic, 4.7mfd, 25WV
C13,49	22446479	Electrolytic, 4.7mfd, 25WV
C14,50	22446479	Electrolytic, 4.7mfd, 25WV
C15,51	22446479	Electrolytic, 4.7mfd, 25WV
C16,52	22447100	Electrolytic, 10mfd, 35WV
C17,53	22447100	Electrolytic, 10mfd, 35WV
C18,54	22446479	Electrolytic, 4.7mfd, 25WV
C19,55	22447100	Electrolytic, 10mfd, 35WV
C20,56	22447100	Electrolytic, 10mfd, 35WV
C21,57	22446470	Electrolytic, 47mfd, 25WV
C22,58	22343102	Ceramic, 1000pF, 50WV, M
C23,59	22343472	Ceramic, 0.0047mfd, 50WV, M
C24,60	22447100	Electrolytic, 10mfd, 35WV
C27,63	22373563	Mylar, 0.056mfd, 50WV, M
C28,64	22446479	Electrolytic, 4.7mfd, 25WV
C29,65	22373393	Mylar, 0.039mfd, 50WV, M
C30,66	22443470	Electrolytic, 47mfd, 10WV
C31,67	22373393	Mylar, 0.039mfd, 50WV, M
C32,68	22447100	Electrolytic, 10mfd, 35WV
C33,69	22443470	Electrolytic, 47mfd, 10WV
C34,70	22373102	Mylar, 1000pF, 50WV, M
C35,71	22382101	Polystyrene, 100pF, 50WV, K
C36,72	22382271	Polystyrene, 270pF, 50WV, K
C73	22447100	Electrolytic, 10mfd, 35WV
C74	22446101	Electrolytic, 100mfd, 25WV
C75	22448339	Electrolytic, 3.3mfd, 50WV
C76	22448339	Electrolytic, 3.3mfd, 50WV
C77	22447100	Electrolytic, 10mfd, 35WV
C78	22447100	Electrolytic, 10mfd, 35WV
C79	22448109	Electrolytic, 1mfd, 50WV
C80	22448109	Electrolytic, 1mfd, 50WV
C81	22448109	Electrolytic, 1mfd, 50WV
C82	22446470	Electrolytic, 47mfd, 25WV
C83	22446470	Electrolytic, 47mfd, 25WV
C84	22446470	Electrolytic, 47mfd, 25WV
C85	22445470	Electrolytic, 47mfd, 16WV
C86	22447100	Electrolytic, 10mfd, 35WV
C87	22445101	Electrolytic, 100mfd, 16WV
C88	22445101	Electrolytic, 100mfd, 16WV
C89	22385332	Polystyrene, 0.0033mfd, 250WV
C90	22373103	Mylar, 0.01mfd, 50WV, M
C91	22373222	Mylar, 0.0022mfd, 50WV, M
C92	22373222	Mylar, 0.0022mfd, 50WV, M
C93	22373223	Mylar, 0.022mfd, 50WV, M
C94	22447100	Electrolytic, 10mfd, 35WV
C95	22343103	Ceramic, 0.01mfd, 50WV, M
C96	22343103	Ceramic, 0.01mfd, 50WV, M
C97	22446479	Electrolytic, 4.7mfd, 25WV

Symbol No.	Part No.	Description
C98	22446479	Electrolytic, 4.7mfd, 25WV
C99	22448339	Electrolytic, 3.3mfd, 50WV
Polwer Supply Circuit		
C1	22430038	Electrolytic, 4700mfd, 35WV
C2	22447101	Electrolytic, 100mfd, 35WV
C3	22343103	Ceramic, 0.01mfd, 50WV, M
C4	22446331	Electrolytic, 330mfd, 25WV
C5	22446101	Electrolytic, 100mfd, 25WV
C6	22343103	Ceramic, 0.01mfd, 50WV, M
C7	22445470	Electrolytic, 47mfd, 16WV
C8	22445470	Electrolytic, 47mfd, 16WV
C9	22446470	Electrolytic, 47mfd, 25WV
C10	22446470	Electrolytic, 47mfd, 25WV
C11	22445471	Electrolytic, 470mfd, 16WV
C12	22445471	Electrolytic, 470mfd, 16WV
C13	22447100	Electrolytic, 10mfd, 35WV
C14	22340030	Ceramic, 0.01mfd, 500WV, P
Dolby Circuit		
C301,401	22401003	Electrolytic, 1mfd, 35WV
C302,402	22448339	Electrolytic, 3.3mfd, 50WV
C303,403	22370149	Polypropylene, 5600pF, 100WV, G
C304,404	22370148	Polypropylene, 0.027mfd, 100WV, G
C305,405	22370150	Polypropylene, 4700pF, 100WV, G
C306,406	22445100	Electrolytic, 10mfd, 16WV
C307,407	22445100	Electrolytic, 10mfd, 16WV
C308,408	22371473	Mylar, 0.047mfd, 50WV, J
C309,409	22445100	Electrolytic, 10mfd, 16WV
C310,410	22372104	Mylar, 0.1mfd, 50WV, K
C311,411	22372334	Mylar, 0.33 mfd, 50 WV, K
C312,412	22445331	Electrolytic, 330mfd, 16WV
C313,413	22446470	Electrolytic, 47mfd, 25WV
C314,414	22382101	Polystyrene, 100pF, 50WV, K
RESISTORS		
All resistors are 1/8W, 5% carbon film unless otherwise noted.		
Main Amplifier Circuit		
R1,25	22554222	2.2K ohm (TZ)
	22554472	4.7K ohm (TE)
R2,26	22554100	10 ohm
R3,27	22554334	330K ohm
R5,29	22554564	560K ohm
R6,30	22554102	1K ohm
R7,31	22554273	27K ohm
R8,32	22554182	1.8K ohm
R9,33	22554184	180K ohm
R10,34	22554563	56K ohm
R11,35	22554682	6.8K ohm
R12,36	22554225	2.2M ohm

Symbol No.	Part No.	Description
R13,37	22554681	680 ohm
R14,38	22554392	3.9K ohm
R15,39	22554103	10K ohm
R16,40	22554224	220K ohm
R17,41	22554225	2.2M ohm
R18,42	22554473	47K ohm
R19,43	22554333	33K ohm
R20,44	22554224	220K ohm
R21,46	22554104	100K ohm
R22,47	22554473	47K ohm
R23,48	22554473	47K ohm
R24,49	22554183	18K ohm
R50	22554683	68K ohm
R52	22554333	33K ohm
R53	22554333	33K ohm
R54	22554182	1.8K ohm
R55	22554330	33 ohm
R56	22554221	220 ohm
R57	22554104	100K ohm
R58	22572471	470 ohm, 1W, $\pm 10\%$, Metal Oxide Film
R59	22554183	18K ohm
R60	22554683	68K ohm
R61	22554473	47K ohm
R62	22554334	330K ohm
R63	22554334	330K ohm
R64	22554103	10K ohm
R65	22554103	10K ohm
R66	22554473	47K ohm
R67	22554473	47K ohm
R68	22554332	3.3K ohm
R69	22563470	47 ohm, 1/2W, Composition
Power Supply Circuit		
R1	22563821	820 ohm, 1/2W, Composition
R2	22563152	1.5K ohm, 1/2W, Composition
R3	22563229	2.2 ohm, 1/2W, Composition
R4	22563272	2.7K ohm, 1/2W, Composition
R5	22563122	1.2K ohm, 1/2W, Composition
R6	22563272	2.7K ohm, 1/2W, Composition
R7	22554472	4.7K ohm
R8	22554104	100K ohm
R9	22554102	1K ohm
R10	22554822	8.2K ohm
R11	22554332	3.3K ohm
R12	22554103	10K ohm
R13	22554820	82 ohm
R14	22554103	10K ohm
R15	22554473	47K ohm
R16	22554332	3.3K ohm
R17	22554683	68K ohm
R18	22554103	10K ohm
R21	22554102	1K ohm
R22	22554102	1K ohm

Symbol No.	Part No.	Description
Push Switch Circuit		
R101,102	22544332	3.3K ohm
R103,104	22544333	33K ohm (TZ)
	22544273	27K ohm (TE)
Jack Circuit		
R105,106	22544333	33K ohm (TZ)
	22544273	27K ohm (TE)
R107,108	22544332	3.3K ohm
R109,110	22544332	3.3K ohm
R111,112	22544103	10K ohm (TZ)
R113,114	22544472	4.7K ohm (TZ)
ASO Circuit		
R101A	22544273	27K ohm
R102A	22544332	3.3K ohm
Dolby Circuit		
R301,401	22554223	22K ohm
R302,402	22540011	3.3K ohm
R303,403	22554181	180 ohm
R304,404	22553473	47K ohm
R305,405	22554104	100K ohm
R306,406	22554121	120 ohm
R307,407	22553684	680K ohm
R308,408	22553154	150K ohm
R309,409	22554274	270K ohm
R310,410	22554391	390 ohm
R311,411	22554105	1M ohm
Main Amplifier Circuit		
VR3,5	22658293	47K ohm, Semi-fixed
VR4,6	22658293	47K ohm, Semi-fixed
VR7,8	22658293	47K ohm, Semi-fixed
VR9,10	22658293	47K ohm, Semi-fixed
VR11,12	22658293	47K ohm, Semi-fixed
VR101,102	22651420	100K ohm, Variable
VR103	22651421	100K ohm, Variable
PRINTED-RESISTORS-CIRCUIT		
Main Amplifier Circuit		
PR1		560 ohm
PR2,3		150K ohm
PR5		1K ohm
PR6,22		6.8K ohm
PR7,23		2.2K ohm
PR8,24		18K ohm
PR11,29		18K ohm
PR12,26		82K ohm
PR14,30		22K ohm
PR15,31		820 ohm
PR16,32		1.5K ohm
PR17,33		22K ohm

Symbol No.	Part No.	Description	Symbol No.	Part No.	Description
PR18,34		22K ohm	42	25771519	Spring, Take-up Lever
PR19,35		100K ohm	43	25771450	Spring, Take-up Lever
PR20,36		3.3K ohm	44	25771571	Spring, Lever Switch
PR21,37		390 ohm	47	25771648	Spring, Operation
PR38		180 ohm	48	25771662	Spring, Rewind Lever
PR39		390K ohm	49	25764196	Washer
PR40,41		330K ohm	50	25764394	Washer
PR42		10K ohm	51	25773206	Spring, Prevention Lever
PR43,44		330K ohm	52	25771704	Spring, Pressure Roller
PR45		1.5K ohm	53	25724420	Bush
PR46,52		180K ohm	54	25771661	Spring, Cassette-up
PR47,53		15K ohm	56	25713383	Dial Pulley
PR48,54		2.2K ohm	58	25771409	Spring, Lock Plate
PR49,55		100 ohm	59	25771410	Spring, Head Chassis
PR50		3.3K ohm	60	25771406	Spring, Operation Plate, Play
PR51,57		22K ohm	61	25771647	Spring, Operation Plate, Fast Forward
PR58		680 ohm	62	25771578	Spring, Fast Forward Lever
PR59,61		2.7K ohm	63	25771451	Spring, Rewind Lever
PR60,62		220 ohm	64	25773240	Spring, Pause Lever
PR63		220 ohm	65	25772240	Spring, Head
PR65		1K ohm	66	25755291	Belt, Counter
PR66		1K ohm	67	25755292	Belt, Counter
PR67		10K ohm	68	25764400	Washer, Pause Lever
			69	25764398	Washer, Capstan Holder
MECHANICAL PARTS			73	25735159	E Washer, Hub Plate
2	25711548	Operation Plate, Pause	74	74050020	E Washer, Hub Plate
3	25741448	Operation Plate, Fast Forward	75	70432605	Screw (BID), M2.6 x 6mm
4	25741399	Operation Plate, Play	76	70432005	Screw (BID), M2 x 5mm
5	25741402	Operation Plate, Rewind	78	70442606	Screw (FLT), M2.6 x 6mm
6	25741400	Operation Plate, Record	80	25771408	Spring, Pause Lever
7	25741460	Operation Plate, Stop	81	25764386	Nylon Sheet
8	25741419	Lock Plate	82	70432004	Screw (BID), M2 x 4mm
10	25773182	Spring, Switch Lever	83	25773164	Spring, Torsion
12	25751390	Pulley	84	25873155	Counter
18	25751501	Pulley, Motor	88	25761305	Tube
19	22125638	Motor	91	25816384	Push Lever Ass'y
20	22701431	Screw (BID), M2.6 x 6mm	93	25773229	Spring, Push Lever
21	25712289	Hub Plate, Take-up	94	25782124	Plate, Spring
22	25717321	Flywheel	98	25858224	Rubber Cap
23	25755316	Belt, Drive	100	25761220	Cushion, Motor
25	25718135	Holder, Capstan	101	25816386	REC Lever Ass'y
26	25712299	Hub Plate Chassis Ass'y	102	70432604	Screw (BID), M2.6 x 4mm
27	25717327	Pressure Roller	103	25713379	ASO Pulley Ass'y
28	22218171	Erase Head	106	25772344	Spring
29	22217245	Record/Playback Head	109	25773245	Spring, Prevention Lever, Record
33	25764402	Washer	111	25761295	Cushion, Push Button
34	25764246	Washer	112	25773178	Spring, Torsion
35	25713404	Pulley, Take-up Ass'y	113	22705022	Rivet
36	25712290	Hub Plate, Supply	114	22703110	Spacer
37	25713403	Pulley, Rewind	115	25774375	Spring
38	25755171	Belt, Rewind	116	25757120	Steel Ball
39	25713281	Idler, Fast Forward	117	25720118	Screw (FLT), M2.6 x 4mm
40	25772154	Spring, Back Tension	118	25764399	Washer, ASO Pulley
41	25764298	Washer, Take-up	121	25722327	Shaft

Symbol No.	Part No.	Description
122	74050015	E Washer
123	25711517	Holder, Cassette
127	25735202	Washer
128	25764404	Washer
CABINET PARTS		
B1	25822463	Top Cover
B2 to B7	25811523	Mechanism Cover Ass'y
B3	25822426	Cover, Head
B4	25812539	Cassette Cover Ass'y
B6	25753258	Roller, Guide
B8	25813151	Front Panel Ass'y
B9	22824177	Knob Ass'y
B10	25836326	Knob, Lever
B11	25836313	Knob, Push
B12	25836315	Knob, BALANCE and OUT- PUT/LEVEL
B13	25836316	Knob, RECORD LEVEL
B14	25822416	Bottom Cover
B15	22828031	Foot
B16	25772345	Spring, Push Button
B17	25836314	Stopper
B18	25822464	Jack Plate (TZ)
	25822476	Jack Note (TE)
B19	22162338	Terminal, Earth
B20	22950291	Label, Dolby
B21	25827303	Model No. Plate (TZ)
	25827304	Model No. Plate (TE)
B22	22701321	Screw (BID), M3 x 6mm
B23	70432605	Screw (BID), M2.6 x 5mm
B24	70442606	Screw (FLT), M2.6 x 6mm
ACCESSORIES		
	22164447	Cord, Connect
	22170109	Patch Cord, TSC-2
	22990283	Cleaner, Head
	22954151	Owner's Manual (TZ)
	22954152	Owner's Manual (TE)



MANUFACTURED BY
TOKYO SHIBAURA ELECTRIC CO., LTD.
2-1, GINZA 5-CHOME, CHUO-KU, TOKYO 104, JAPAN
CABLE: TOSHIBAGNZ TOKYO, TELEX NO.: J24681, J24682, J24683

22955268 OCT. '75 PRINTED IN JAPAN

