

TOSHIBA

STEREO AMPLIFIER

SB-A50



SPECIFICATIONS

General		Frequency Response:	5 kHz ~ 100 kHz (+0, -3 dB)
Power Supply:	220V - 50 Hz for Europe or 240V - 50 Hz for the United Kingdom and Australia	Power Band Width (IHF):	10 Hz ~ 35 kHz
Power Consumption:	290W	Load Impedance:	4 ohm ~ 16 ohm
Weight:	5.4 kg	Damping Factor:	25
Dimensions (mm):	420(W) x 116(H) x 286(D)	S/N (IHF A Network):	90 dB (TUNER/AUX) 70 dB (PHONO)
Amplifier		Input Sensitivity/ Impedance:	PHONO 2.5mV/47k ohm TUNER 150mV/47k ohm AUX/TAPE 150mV/47k ohm MIC 1.0mV/47k ohm
Continuous Power Output 20 Hz ~ 20 kHz both ch. driven:	35W x 2 (4 ohm) 30W x 2 (8 ohm)	Output Level:	TAPE REC 150mV
1 kHz both ch. driven:	38W x 2 (4 ohm) 35W x 2 (8 ohm)	Tone Control:	BASS (at 100 Hz) ±8 dB TREBLE (at 10 kHz) ±8 dB
Total Harmonic Distortion:	0.1% (at rated power 8 ohm)	Phono Overload Level:	150mV (RMS)

Specifications are subject to change without notice.

TE, TU, AY

CONTENTS

1. OPERATING CONTROLS	3
2. SYSTEM CONNECTIONS	4
3. OPERATION	5
4. DISASSEMBLY INSTRUCTIONS	6
5. ADJUSTMENTS	7
6. BLOCK DIAGRAM	8
7. IC BLOCK DIAGRAM	9
8. ELECTRICAL PARTS LOCATIONS	10
9. SCHEMATIC DIAGRAM	11
10. CABINET PARTS LOCATIONS	12
11. PARTS LIST	13 to 14

1. OPERATING CONTROLS

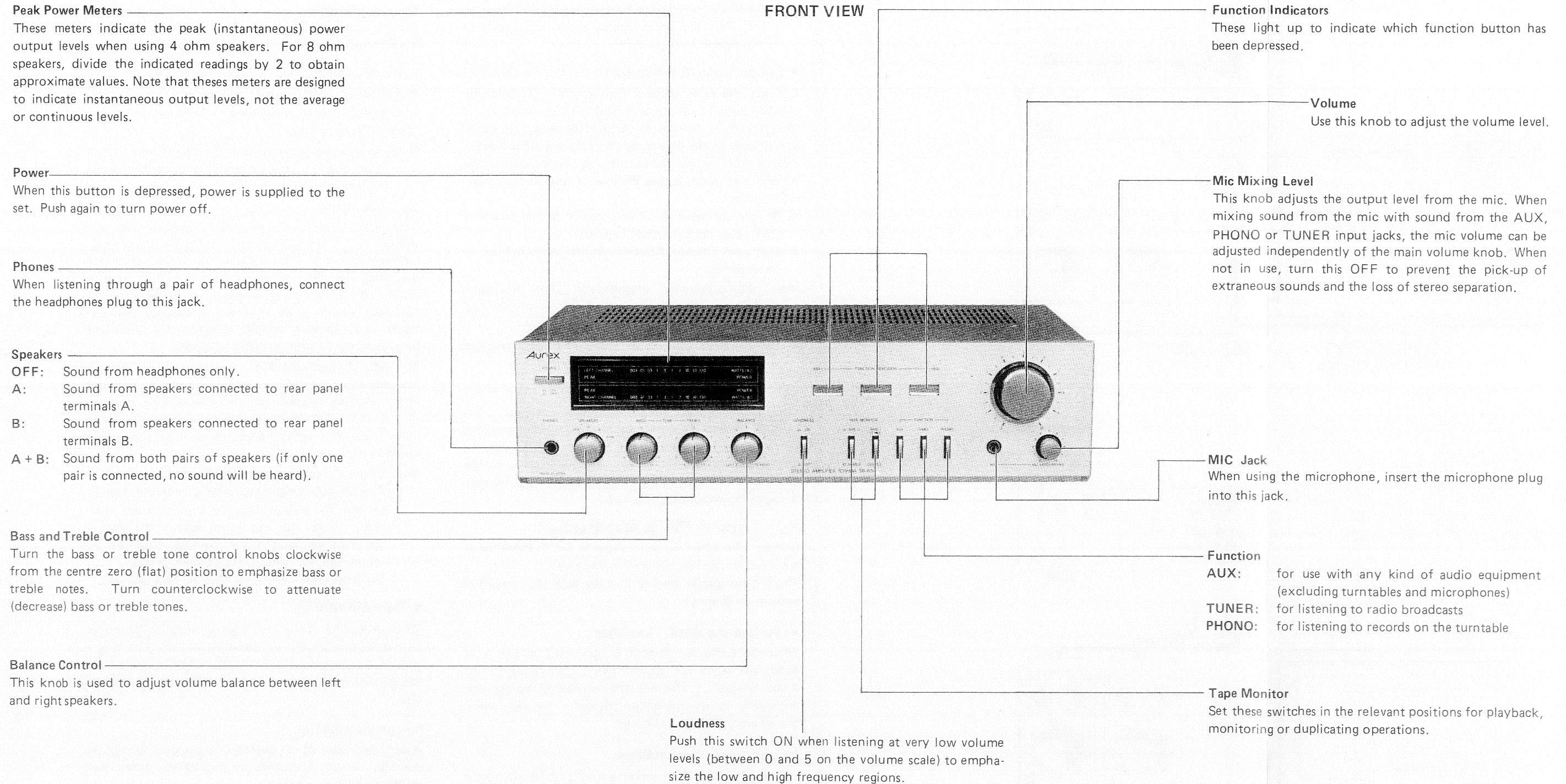

Figure 1

2. SYSTEM CONNECTIONS

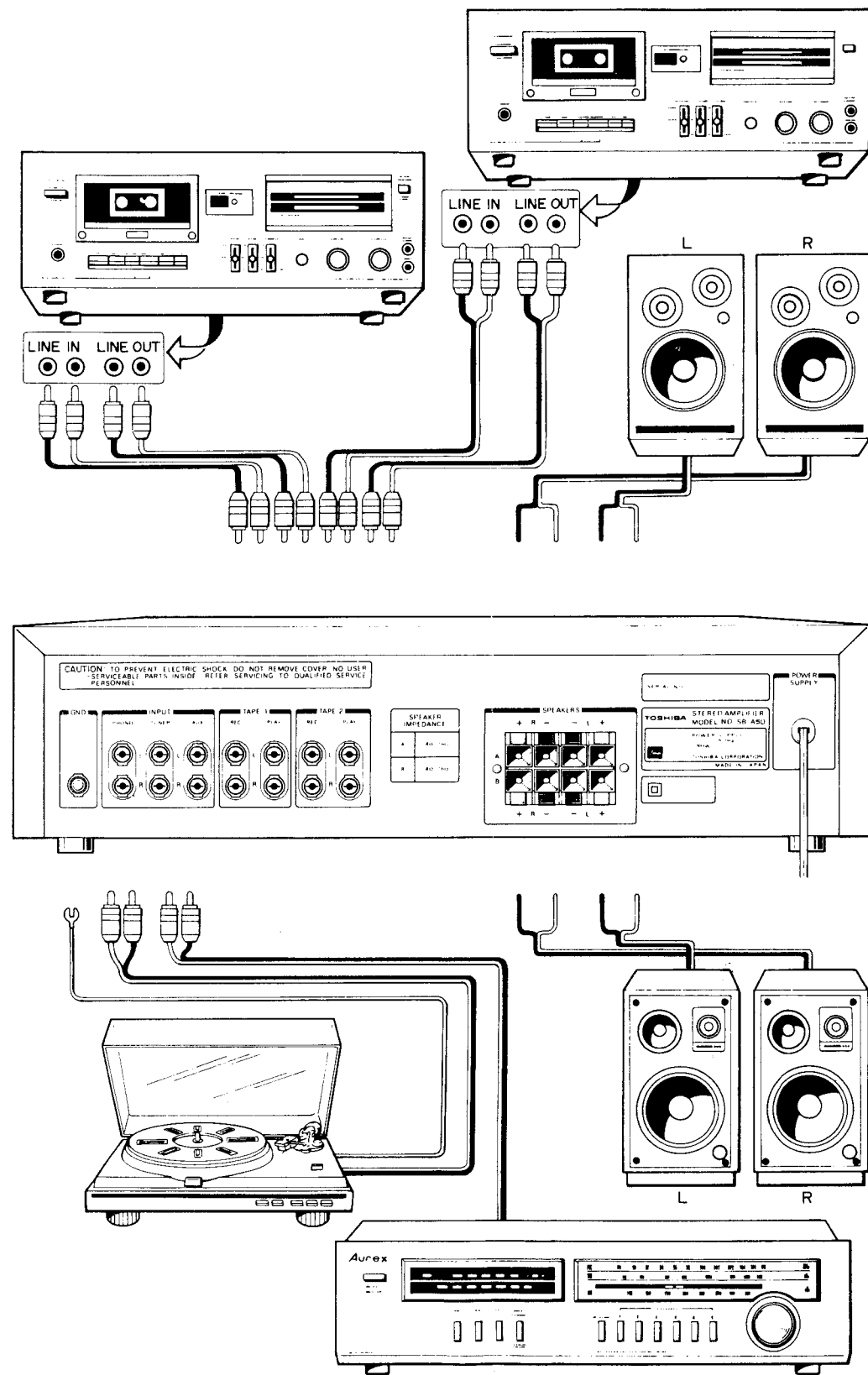

Figure 2

3. OPERATION

Note: Until all connections have been properly completed, leave the power supply cords unplugged and the power switches OFF.

■ Connections of Speakers to the Power Amplifier

Connect the right speaker cord to the "R" amplifier speaker output terminal and the left speaker cord to the "L" terminal. Be sure to connect the plug terminal of the speaker to the plus terminal of the amplifier speaker output terminal and minus to minus. Wrong connection of plus and minus causes the loss of stereophonic playback sound.

- Be sure to leave the power switch of the amplifier OFF while performing connections.
- Don't short-circuit the plus and minus terminals of the speakers.

Note: When using a pair of speakers, use only those with an impedance of at least 4 ohms to avoid overloading the amplifier.

- Confirm that the volume knob is in the 0 position before the power is turned on.

■ To Play Phonograph Records

Connect the output cables from the turntable to the PHONO terminals of the amplifier. If the turntable is equipped with an earth wire or terminal, be sure to connect it to the earth wire terminal (GND) of the amplifier. If this simple task is overlooked, it may result in the generation of a hum.

■ To Listen to FM (or AM) Broadcasts

Connect the tuner output cables to the TUNER input terminals on the rear panel of the amplifier. There is no special need to link the tuner and amplifier with an earth wire.

■ To Use the AUX Terminals

When an audio component is connected to the AUX terminals, place the FUNCTION switch knob in the AUX position. Operate the connected component according to its instruction manual. Finally, adjust the volume and tone as desired.

■ Tape Deck Connections

Connect the tape deck input terminals (LINE IN) to the amplifier's record terminals (REC), and the deck output terminals (LINE OUT) to the amplifier's playback (PLAY) terminals.

(1) To Record

Prepare the program source (turntable, tuner or any other audio program source) to be recorded, and set the tape deck in the recording mode. Note that during the actual recording, the amplifier volume and tone controls will have no effect on the recording level or tone. Two separate tape decks may be used simultaneously.

(2) To Playback

Set the corresponding TAPE MONITOR switch to the TAPE position and turn the tape deck on for playback.

■ Mic Mixing and Mic Mixing Recording

The SB-A50 is also designed to permit both direct mic mixing with a tuner, turntable or other audio source and mic mixing recording.

Note: Always remember to turn the microphone volume level down to the minimum position before unplugging the microphone.

(1) Mic Mixing

Plug in the microphone to the microphone jack and prepare the phonograph record or FM broadcast as for ordinary listening. Turn the mic mixing knob around in the clockwise direction to adjust the relative volume levels. The SOURCE volume level is then adjusted by the main volume knob. To mix an already recorded signal with another, simply connect the tape deck outputs to the SB-A50 auxiliary terminals.

(2) Mic Mixing Recording

The mic mixing described above may also be recorded on a tape deck connected to the SB-A50. Note, however that the amplifier volume and tone control knobs can no longer be used in adjusting volume level and tone of the sound being recorded.

Note: About the speaker protective fuses:

The SB-A50 is equipped with a protective fuse to protect the output circuitry from a power overload. If the plus and minus sides of the speaker terminals are shorted, the fuse will blow and no sound will be heard. Please take this unit to a qualified service centre to have the fuse replaced.

■ Tape Monitoring

When recording with a tape deck equipped with proper tape monitoring facilities, monitoring of the recording is possible by moving the TAPE MONITOR switch from the SOURCE position to the corresponding TAPE position.

■ Tape Duplication

A recorded tape can be copied onto another tape in its entirety, or can be edited by duplicating only those portions which are desired.

■ Duplication from TAPE 1 to TAPE 2

1. Depress the TAPE MONITOR switch to TAPE 2 ◀ 1.
2. The TAPE 2 switch should be left in the SOURCE position (out); if depressed, duplication is still possible but no sound will be heard.
3. The tape deck connected to TAPE 1 should be played and the tape deck connected to TAPE 2 should be used to record.

Note: Duplication from TAPE 2 to TAPE 1 is not possible.

4. DISASSEMBLY INSTRUCTIONS

REMOVAL OF TOP COVER

1. Remove two screws ① ($3\phi \times 6\text{mm}$) from both sides of top cover as shown in Figure 3.
2. Remove two screws ② ($3\phi \times 8\text{mm}$) from back side of top cover, then top cover can be removed as shown in Figure 4.

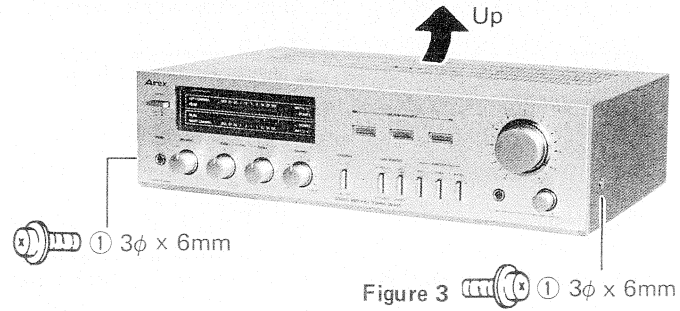

REMOVAL OF FRONT PANEL

1. Remove top cover as shown in Figures 3 and 4.
2. Remove three screws ③ ($3\phi \times 8\text{mm}$) holding front panel and back plate as shown in Figure 5.
3. Remove three screws ④ ($3\phi \times 8\text{mm}$) holding front panel and bottom plate, then front panel can be removed as shown in Figure 6.

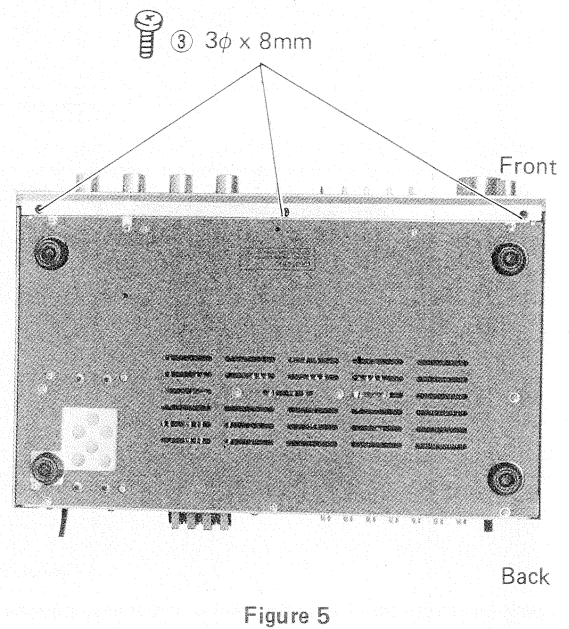
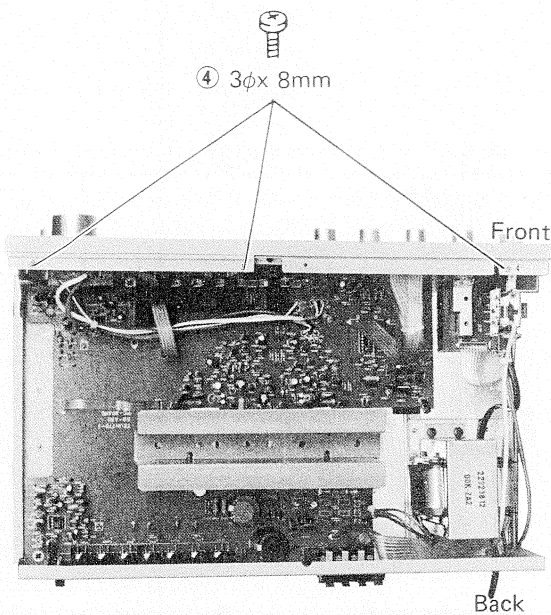
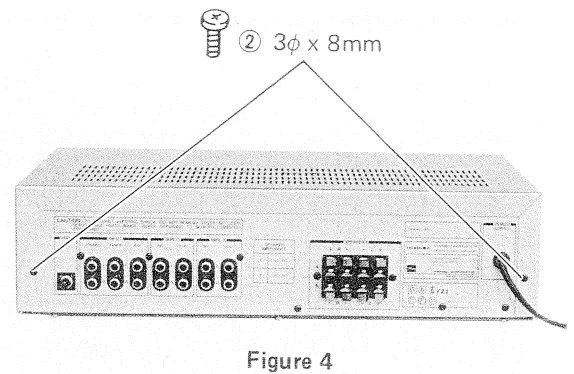

5. ADJUSTMENTS

IDLE CURRENT ADJUSTMENT

1. Idle current adjustment can easily be done by setting the semi-fixed VR R625, 626 (300 ohm) to mechanical mid point VR as shown in Figure 7.
2. The idle current between TP and TP must be less than 2mA when power has been on for 30 seconds.

LED LEVEL ADJUSTMENT

1. Right channel is fixed.
2. Only left channel can be varied. Adjust semi-fixed VR R703 (5K ohm) so that the LED lighting level of right channel is equal to that of left channel.

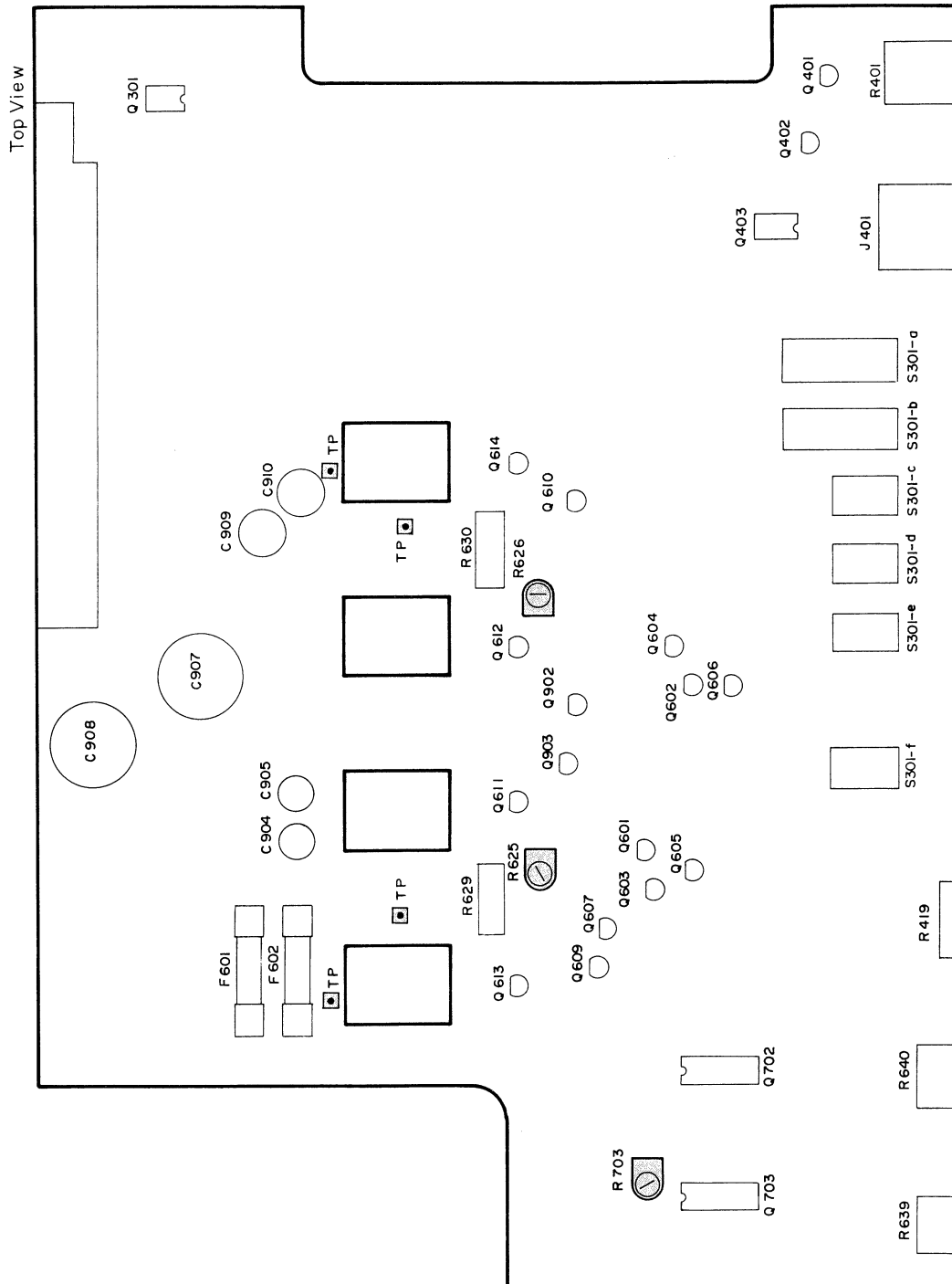

Figure 7

6. BLOCK DIAGRAM

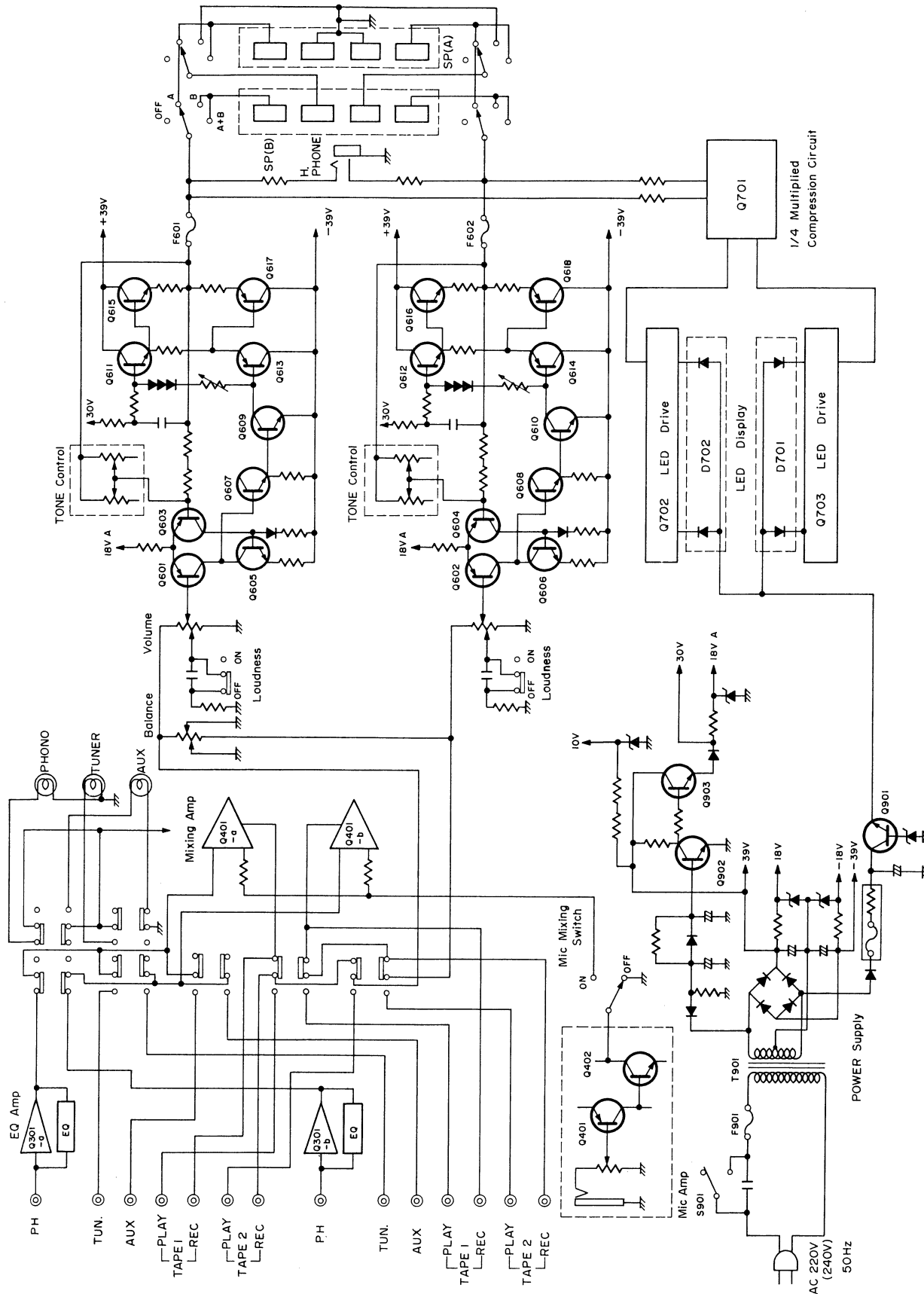
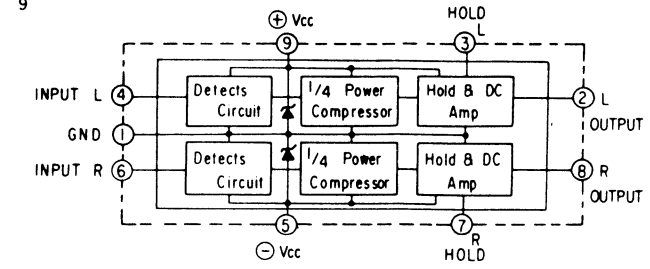
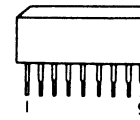

Figure 8

7. IC BLOCK DIAGRAM

TA7318P



NJM4558D-K

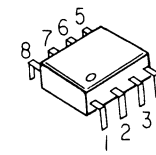

Connection Diagram (Top View)

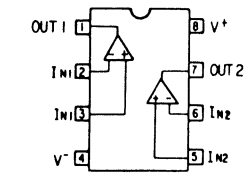

Equivalent Circuit (1/2 Circuit)

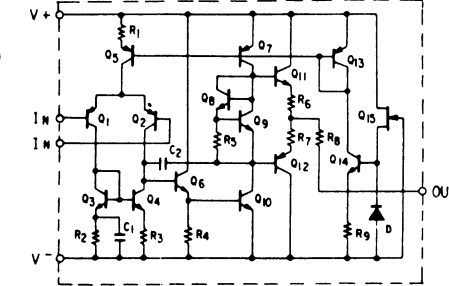

TA7612AP

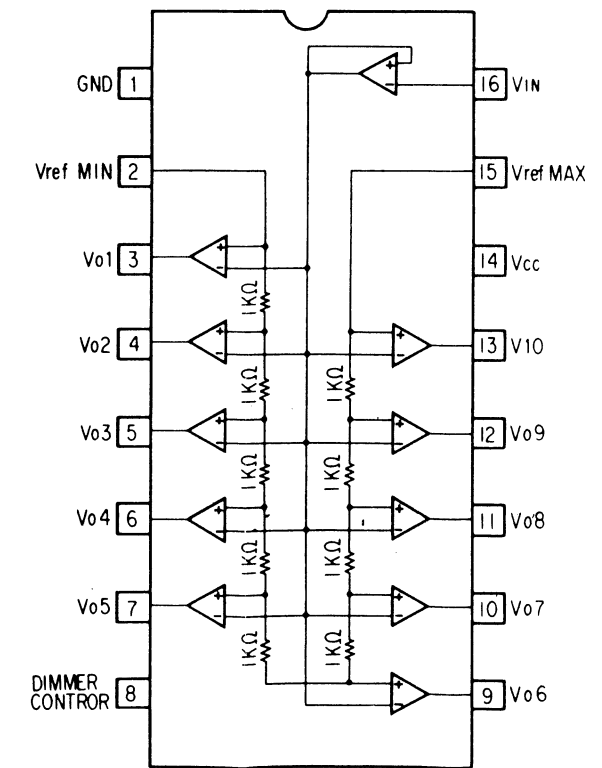
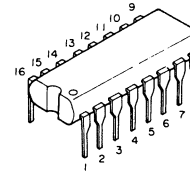
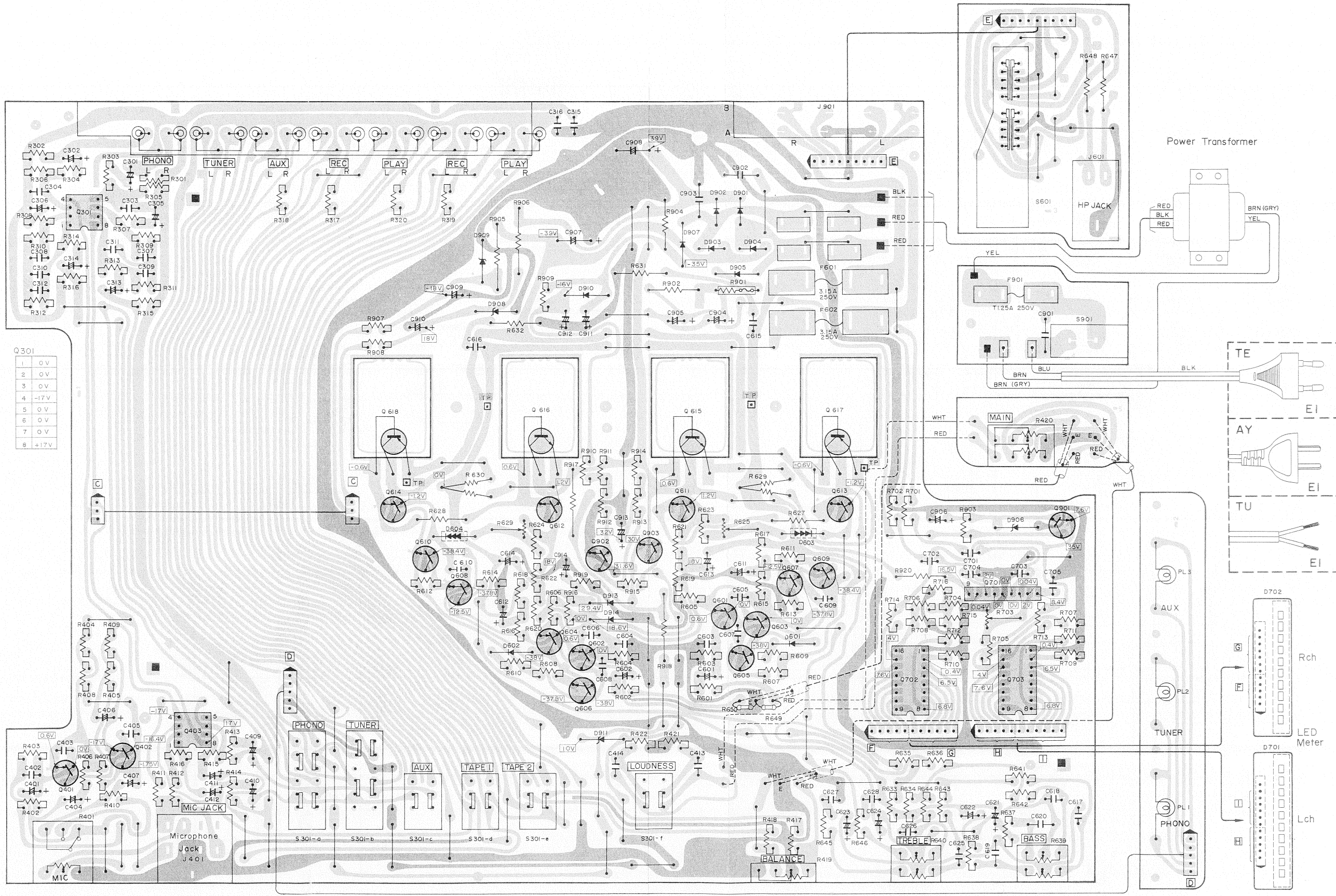

Figure 9

8. ELECTRICAL PARTS LOCATIONS



Q301

1	0V
2	0V
3	0V
4	-17V
5	0V
6	0V
7	0V
8	+17V

Figure 10

9. SCHEMATIC DIAGRAM

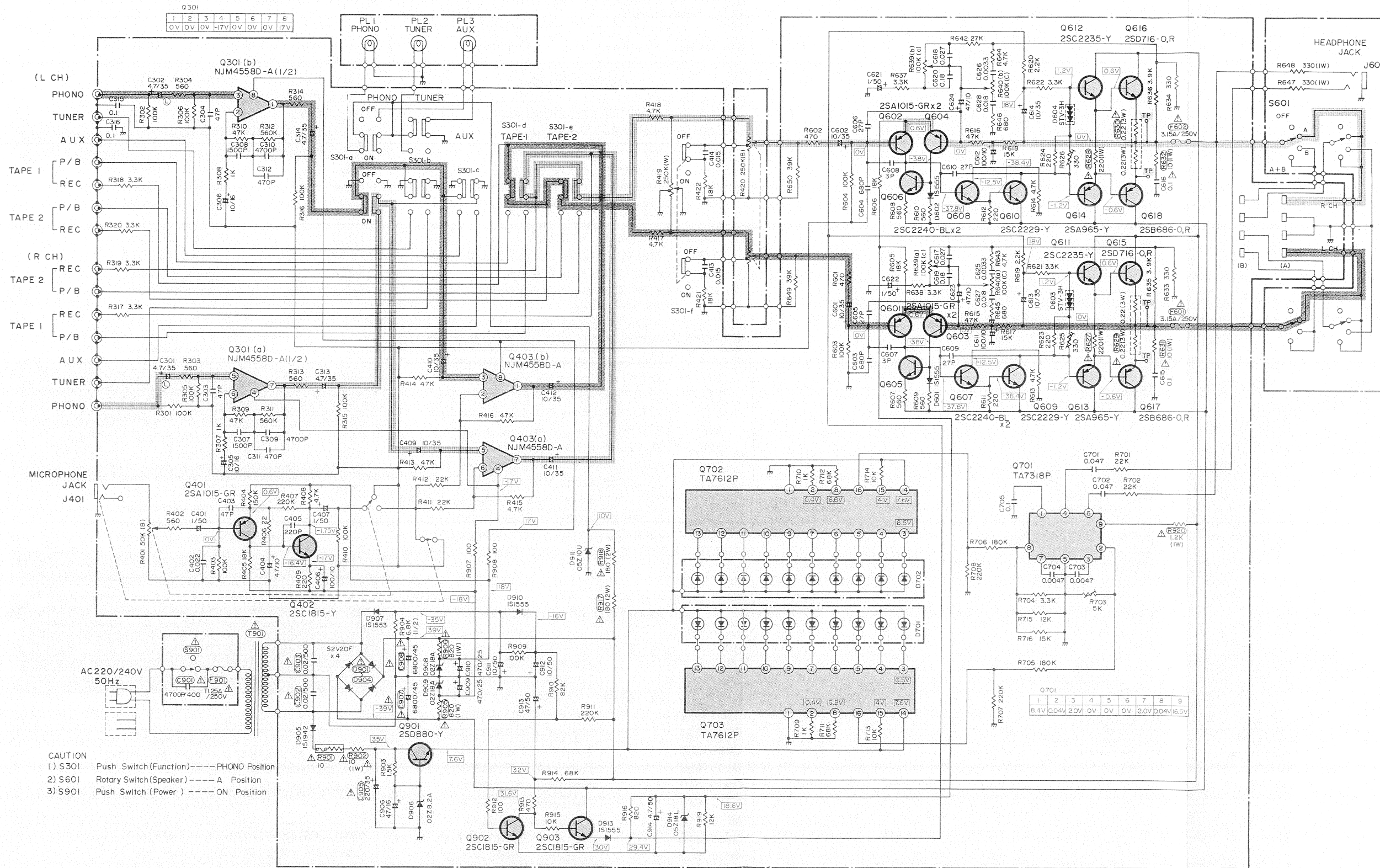

L ch Signal Path
 R ch Signal Path

Figure 11

CAUTION: The Δ mark, the symbol No. circled with rectangle in the schematic diagram and the shaded area in the parts list designate components which have special characteristics important for safety and should be replaced only with types identical to those in the original circuit or specified in the parts list.

10. CABINET PARTS LOCATIONS

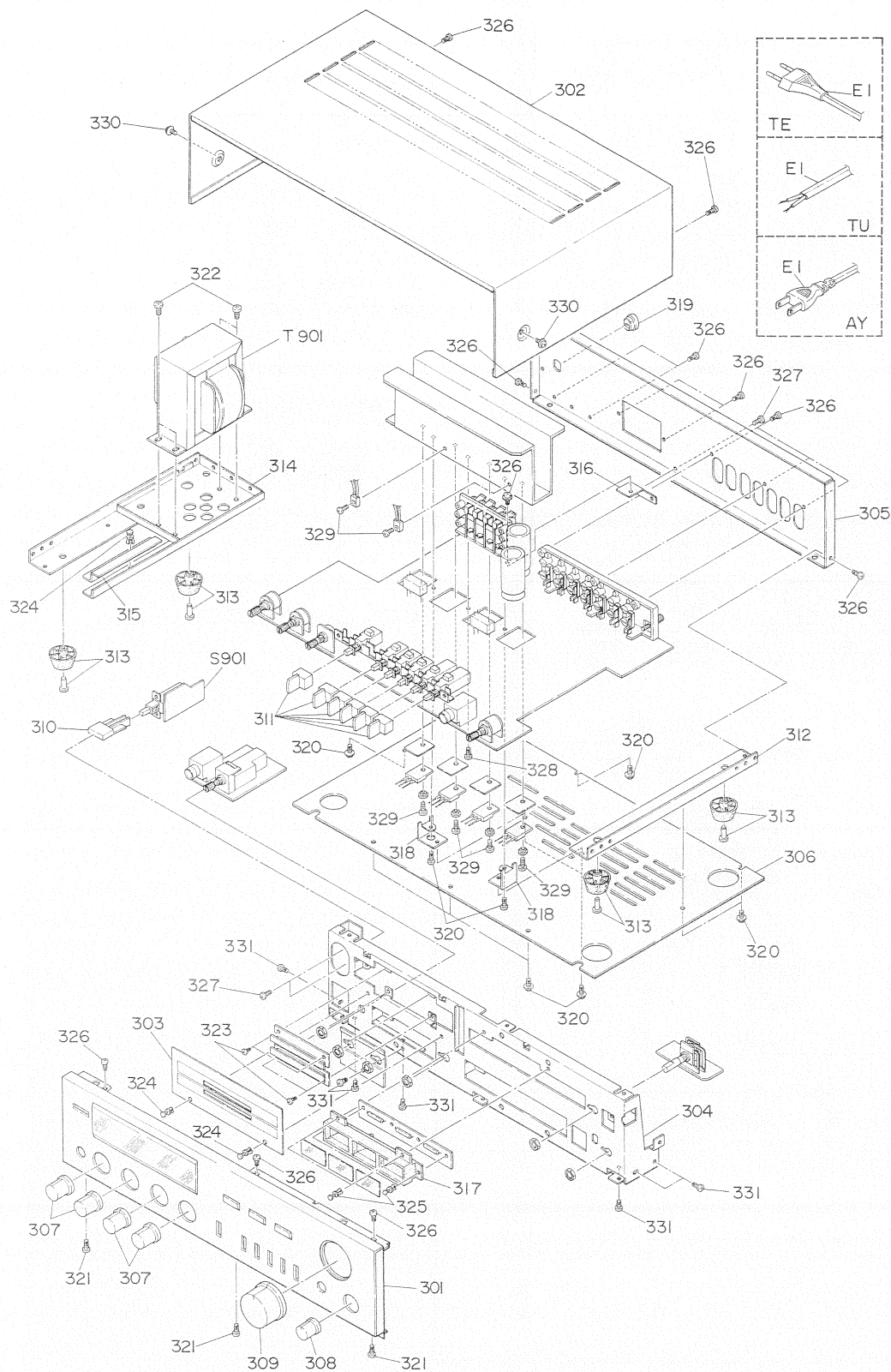

NOTE: Parts excluded in the Parts List are not available as replacement parts.

Figure 12

11. PARTS LIST

CAUTION

The Δ mark, the symbol No. circled with rectangle in the schematic diagram and the shaded area in the parts list designate components which have special characteristics important for safety and should be replaced only with types identical to those in the original circuit or specified in the parts list.

Symbol No.	Part No.	Description	Symbol No.	Part No.	Description
CABINET PARTS					
301	20017152	Front Panel Ass'y	D601, 602	22115481	Diode, 1S1555V
302	20015194	Cover, Top	D603, 604	22115481	Diode, STV-3H
303	20033123	Plate, Decoration	D701, 702		Diode, TLR-8101
305	20015192	Jack Plate (TE)	Δ D901, 902	22115597	Diode, S2V20F
305	20015196	Jack Plate (TU, AY)	Δ D903, 904		
306	20822094	Plate, Bottom	D905		Diode, 1S1942
307	22884011	Knob, TONE	D906		Diode, 02Z8, 2A
308	22884012	Knob, MIX	D907		Diode, 1S1553V
309	22884028	Knob, Ass'y, VOLUME	D908, 909		Diode, 02Z18A
310	25837457	Knob, POWER	D910		Diode, 1S1555V
311	22884013	Knob, Ass'y, Push	D911		Diode, 05Z10-U
313	22828066	Leg	D913		Diode, 1S1555V
317	25841229	Cover, Lamp	C914		Diode, 05Z18-L
Δ 319	25845528	Bush, Nylon	ELECTRICAL PARTS		
320	22701436	Screw, T PAN, 3 ϕ x 8mm	T901	22223812	Transformer, Power (TE)
321	22707590	Screw, T PAN, 3 ϕ x 8mm	Δ T901	22223823	Transformer, Power (TU)
322	22707040	Screw, FT BID, 4 ϕ x 6mm	Δ T901	22223830	Transformer, Power (AY)
323	22707366	Screw, DT BID, 2.6 ϕ x 6mm	S301	22195605	Switch, Push (FUNCTION)
324	22705021	Rivet, Plastic, 3 ϕ x 3.5mm	S601	22195608	Switch, Rotary (SPEAKER)
325	22705034	Rivet, Plastic, 3.5 ϕ x 5.5mm	Δ S901	22195631	Switch, Push (POWER)
326	22701326	Screw, BID, 3 ϕ x 8mm, Tapping	J301	22163810	Jack, Input, 14P
327	22707066	Screw, BID, 3 ϕ x 6mm	J401	22163699	Jack, Microphone
328	22707165	Screw, BID, 3 ϕ x 10mm, Tapping	J601	22163676	Jack, Headphone
329	22707163	Screw, BID, 3 ϕ x 10mm	J901	22162457	Terminal, Speaker
330	22707522	Screw, FL DT, 3 ϕ x 6mm	Δ F601, 602	22144355	Fuse, 3.15A/250V
331	22701237	Screw, BID, 3 ϕ x 6mm, Tapping	Δ F901	22144357	Fuse, 1.25A/250V
TRANSISTORS, IC'S & DIODES					
Q301	22114470	IC, NJM4558D-A	PL1, 2, 3	22113478	Lamp, Pilot 12V/55mA (CLR)
Q401		Transistor, 2SA1015-GR	Δ E1	22176286	Cord, Power (TE)
Q402		Transistor, 2SC1815-Y	Δ E1	22176536	Cord, Power (TU)
Q403	22114470	IC, NJM4558D-A	Δ E1	22176588	Cord, Power (AY)
Q601, 602		Transistor, 2SA1015-GR	Δ E2	22165036	Holder, Fuse (F601, 602)
Q603, 604		Transistor, 2SA1015-GR	Δ E3	22165047	Holder, Fuse (F901)
Q605, 606		Transistor, 2SC2240-BL	CAPACITORS		
Q607, 608		Transistor, 2SC2240-BL	D = ± 0.5 pF, J = $\pm 5\%$, K = $\pm 10\%$, M = $\pm 20\%$, P = $-0 + 100\%$, Z = $-20 + 80\%$		
Q609, 610		Transistor, 2SC2229-Y	ABBREVIATIONS: CD = Ceramic Disk, EL = Electrolytic, MY = Mylar		
Q611, 612		Transistor, 2SC2235-Y	C301, 302	22467479	EL, 4.7mfd, 35V, (LS)
Q613, 614		Transistor, 2SA965-Y	C303, 304	22362470	CD, 47pF, 50V, K
Q615, 616		Transistor, 2SD716-O.R/O	C305, 306	22485100	EL, 10mfd, 16V
Q617, 618		Transistor, 2B686-O.R/O	C307, 308	22371152	MY, 1500pF, 50V, J
Q701		IC, TA7318P	C309, 310	22371472	MY, 4700pF, 50V, J
Q702, 703		IC, TA7612P	C311, 312	22349471	CD, 470pF, 50V, K
Q901		Transistor, 2SD880-Y			
Q902, 903		Transistor, 2SC1815-GR			

Symbol No.	Part No.	Description	Symbol No.	Part No.	Description
C313, 314	22488479	EL, 4.7mfd, 50V	R317, 318	22555332	3.3k ohm
C315, 316	22360333	CD, 0.1mfd, 25V, M	R319, 320	22555332	3.3k ohm
C401	22488109	EL, 1mfd, 50V	R401	22650447	50k ohm, B, Variable
C402	22342223	CD, 0.022mfd, 50V, Z	R402	22555561	560 ohm
C403	22362470	CD, 47pF, 50V, K	R403	22555104	100k ohm
C404	22483470	EL, 47mfd, 10V	R404	22555154	150k ohm
C405	22349221	CD, 220pF, 50V, K	R405	22555183	18k ohm
C406	22483101	EL, 100mfd, 10V	R406	22555220	22 ohm
C407	22488109	EL, 1mfd, 50V	R407	22555224	220k ohm
C409, 410	22487100	EL, 10mfd, 50V	R408	22555472	4.7k ohm
C411, 412	22487100	EL, 10mfd, 50V	R409	22555221	220 ohm
C413, 414	22360546	CD, 0.015mfd, 25V, K	R410	22555104	100k ohm
C601, 602	22487100	EL, 10mfd, 50V	R411, 412	22555223	22k ohm
C603, 604	22349681	CD, 680pF, 50V, K	R413, 414	22555473	47k ohm
C605, 606	22361270	CD, 27pF, 50V, J	R415, 416	22555472	4.7k ohm
C607, 608	22361270	CD, 27pF, 50V, J	R417, 418	22555472	4.7k ohm
C609, 610	22361309	CD, 3pF, 50V, D	R419	22651619	250k ohm, W, Variable (BALANCE)
C611, 612	22483101	EL, 100mfd, 10V	R420	22651615	250k ohm, B, Variable (MAIN)
C613, 614	22487100	EL, 10mfd, 50V	R421, 422	22555183	18k ohm
C615, 616	22360333	CD, 0.1mfd, 25V, M	R601, 602	22555471	470 ohm
C617, 618	22360549	CD, 0.027mfd, 25V, K	R603, 604	22555104	100k ohm
C619, 620	22372184	MY, 0.18mfd, 50V, K	R605, 606	22555183	18k ohm
C621, 622	22488109	EL, 1mfd, 50V	R607, 608	22555561	560 ohm
C623, 624	22483470	EL, 47mfd, 10V	R609, 610	22555561	560 ohm
C625, 626	22360538	CD, 0.0033mfd, 25V, K	R611, 612	22555221	220 ohm
C627, 628	22360547	CD, 0.018mfd, 25V, K	R613, 614	22555472	4.7k ohm
C701, 702	22360552	CD, 0.047mfd, 25V, K	R615, 616	22555473	47k ohm
C703, 704	22360540	CD, 0.047mfd, 25V, K	R617, 618	22555153	15k ohm
C705	22360333	CD, 0.1mfd, 25V, M	R619, 620	22555222	2.2k ohm
△ C901	22340147	CD, 0.01mfd, 400V, P	R621, 622	22555332	3.3k ohm
△ C902, 903	22340032	CD, 0.02mfd, 500V, Z	R623, 624	22555221	220 ohm
△ C905	22487221	EL, 220mfd, 35V	R625, 626	22658500	300 ohm, Semi-fixed
C906	22485470	EL, 47mfd, 16V	△ R627, 628	22570266	220 ohm, 1W
△ C907, 908	22440338	EL, 6800mfd, 50V	△ R629, 630	22500260	0.22 ohm, 3W
C909, 910	22486471	EL, 470mfd, 25V	△ R631, 632	22570250	10 ohm, 1W
C911, 912	22488100	EL, 10mfd, 50V	R633, 634	22555392	3.9k ohm
C913	22488470	EL, 47mfd, 50V	R635, 636	22555331	330 ohm
C914	22488479	EL, 4.7mfd, 50V	R637, 638	22555332	3.3k ohm
RESISTORS			R639, 640	22651618	100k ohm, C, Variable
All resistors are carbon film 1/4W, ±5%, unless otherwise noted.			R641, 642	22555273	27k ohm
R301, 302	22555104	100k ohm	R643, 644	22555472	4.7k ohm
R303, 304	22555561	560 ohm	R645, 646	22555681	680 ohm
R305, 306	22555104	100k ohm	R647, 648	22570268	330 ohm, 1W
R307, 308	22555102	1k ohm	R649, 650	22555393	39k ohm
R309, 310	22555473	47k ohm	R701, 702	22555223	22k ohm
R311, 312	22555564	560k ohm	R703	22658513	5k ohm, Semi-fixed
R313, 314	22555561	560 ohm	R704	22555332	3.3k ohm
R315, 316	22555104	100k ohm	R705, 706	22555184	180k ohm
			R707, 708	22555224	220k ohm
			R709, 710	22555102	1k ohm

Symbol No.	Part No.	Description
R711, 712	22555683	68k ohm
R713, 714	22555103	10k ohm
R715	22555123	12k ohm
R716	22555153	15k ohm
△ R901	22500130	10 ohm, Fusible
△ R902	22570250	10 ohm, 1W
R903	22555152	1.5k ohm
R904	22547682	6.8k ohm, ½W
△ R905, 906	22570273	820 ohm, 1W
R907, 908	22555101	100 ohm
R909	22555104	100k ohm
R910	22555823	82k ohm
R911	22555224	220k ohm
R912	22555101	100 ohm
R913	22555471	470 ohm
R914	22555683	68k ohm
R915	22555103	10k ohm
R916	22555821	820 ohm
△ R917	22570310	180 ohm, 2W
△ R918	22570310	180 ohm, 2W
R919	22555123	12k ohm
△ R920	22570275	1.2k ohm, 1W
ACCESSORY		
	22902702	Owner's Manual

TOSHIBA CORPORATION

2-1, GINZA 5-CHOME, CHUO-KU, TOKYO 104, JAPAN