

Service Manual

AD100VTH

CONTENTS

Block Diagram	: Page 2
Circuit Diagrams:	Page 3-4
Test Mode	: Page 5
Parts List	: Page 6-7

2nd Edition

Issued date: March 29, 2006

Issued by: KORG INC.

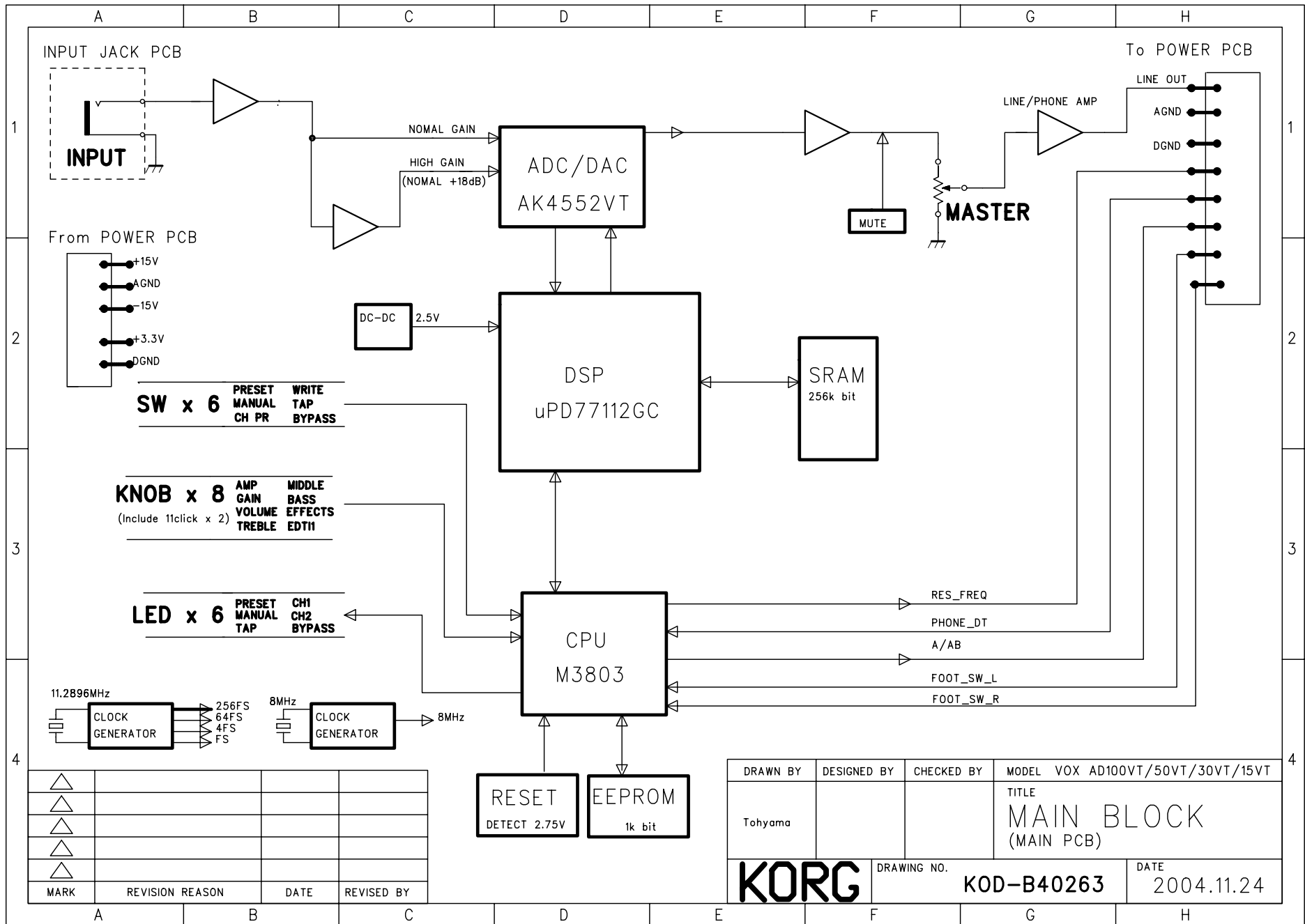

DRAWN BY	DESIGNED BY	CHECKED BY	MODEL VOX AD100VT/50VT/30VT/15VT
Tohyama			TITLE MAIN BLOCK (MAIN PCB)
DRAWING NO. KOD-B40263		DATE 2004.11.24	

KORG

△			
△			
△			
△			
△			
MARK	REVISION REASON	DATE	REVISED BY

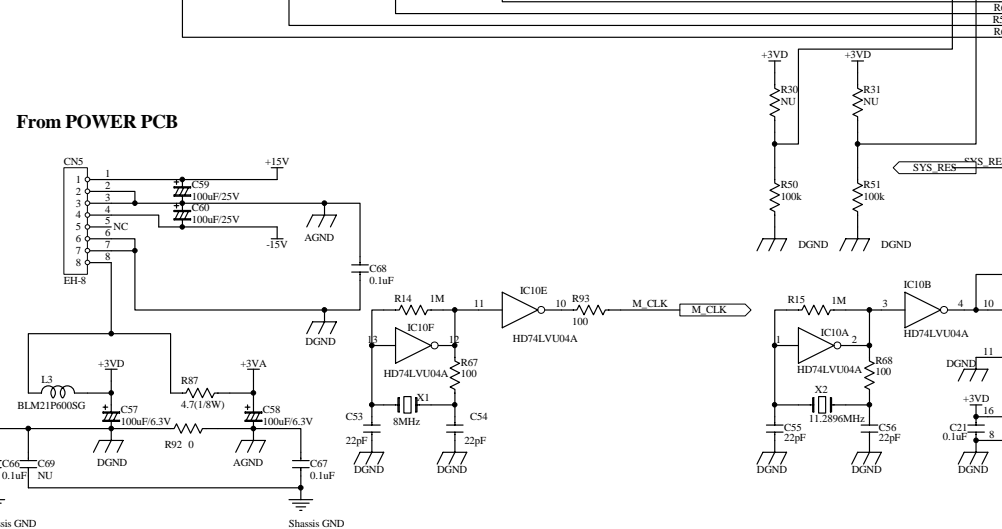
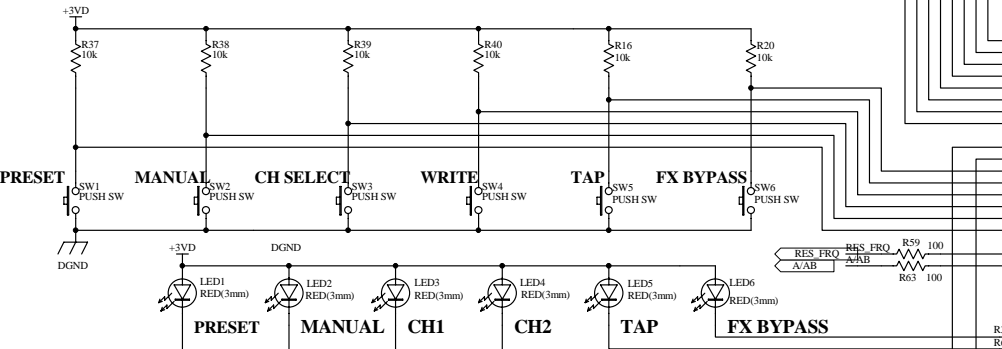
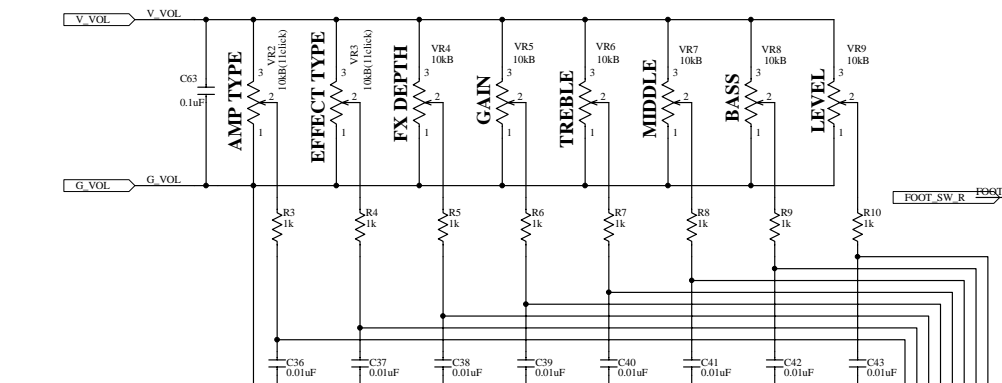
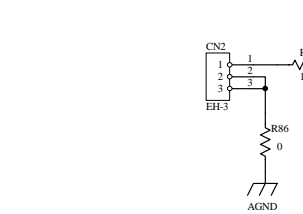
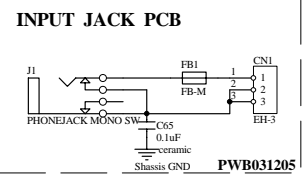

From POWER PCB

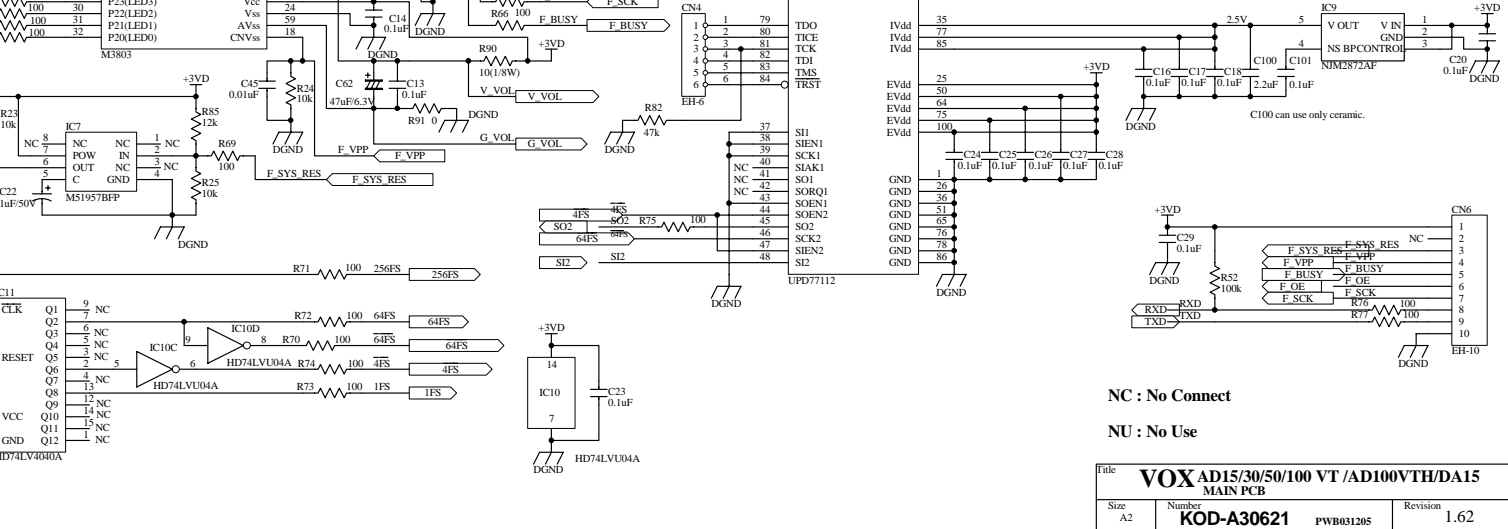
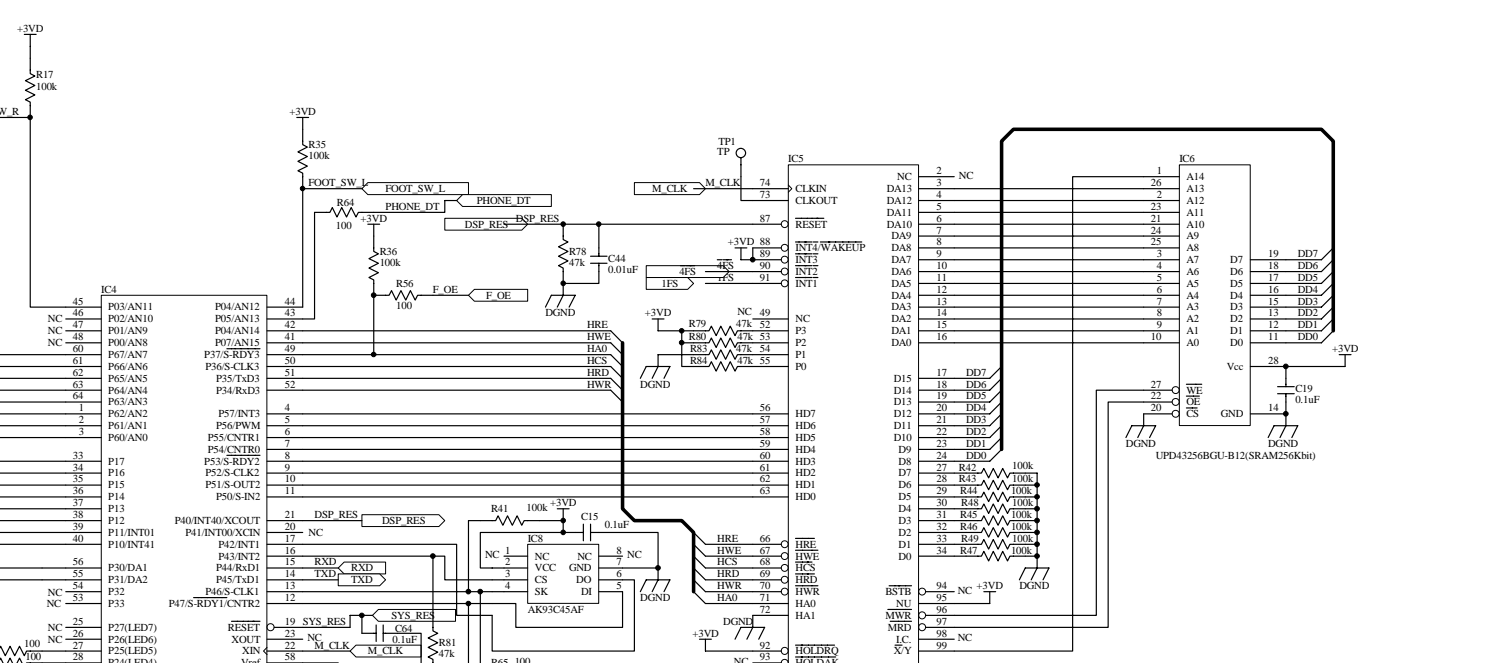
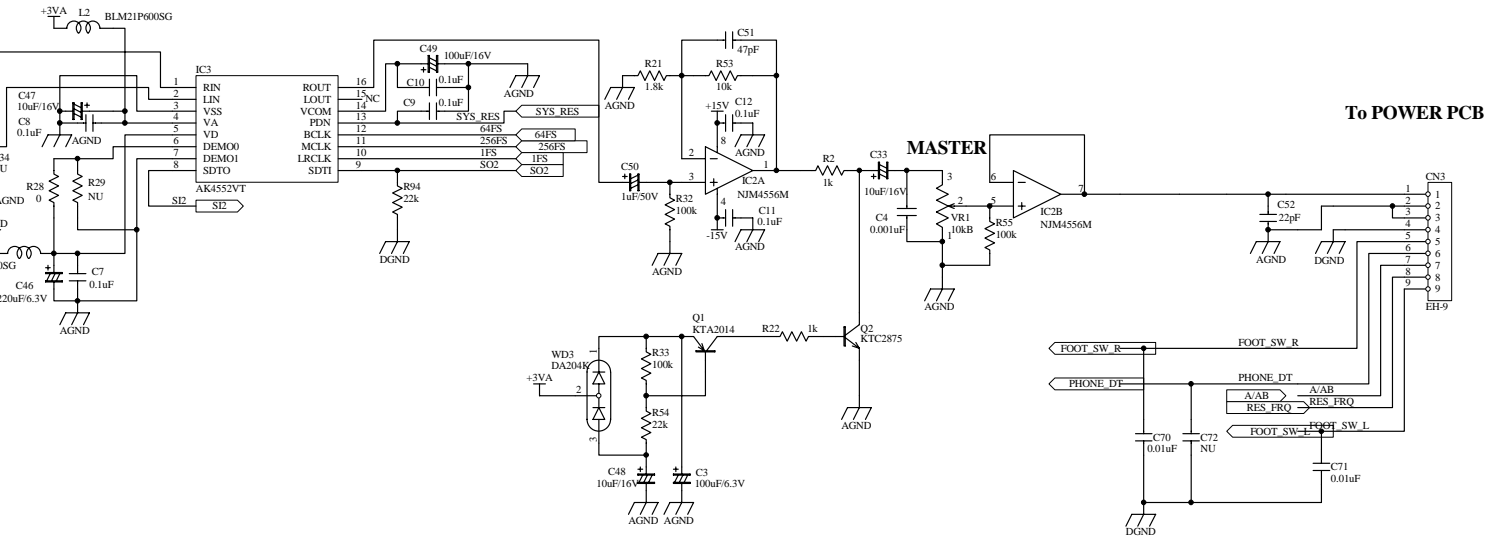

NC : No Connect
NU : No Use

File: VOX AD15/30/50/100 VT /AD100VTH/DA15		
MAIN PCB		
Size: A2	Number: KOD-A30621	Revision: 1.62
Date: 2004.09.14	Sheet of: 1/2	

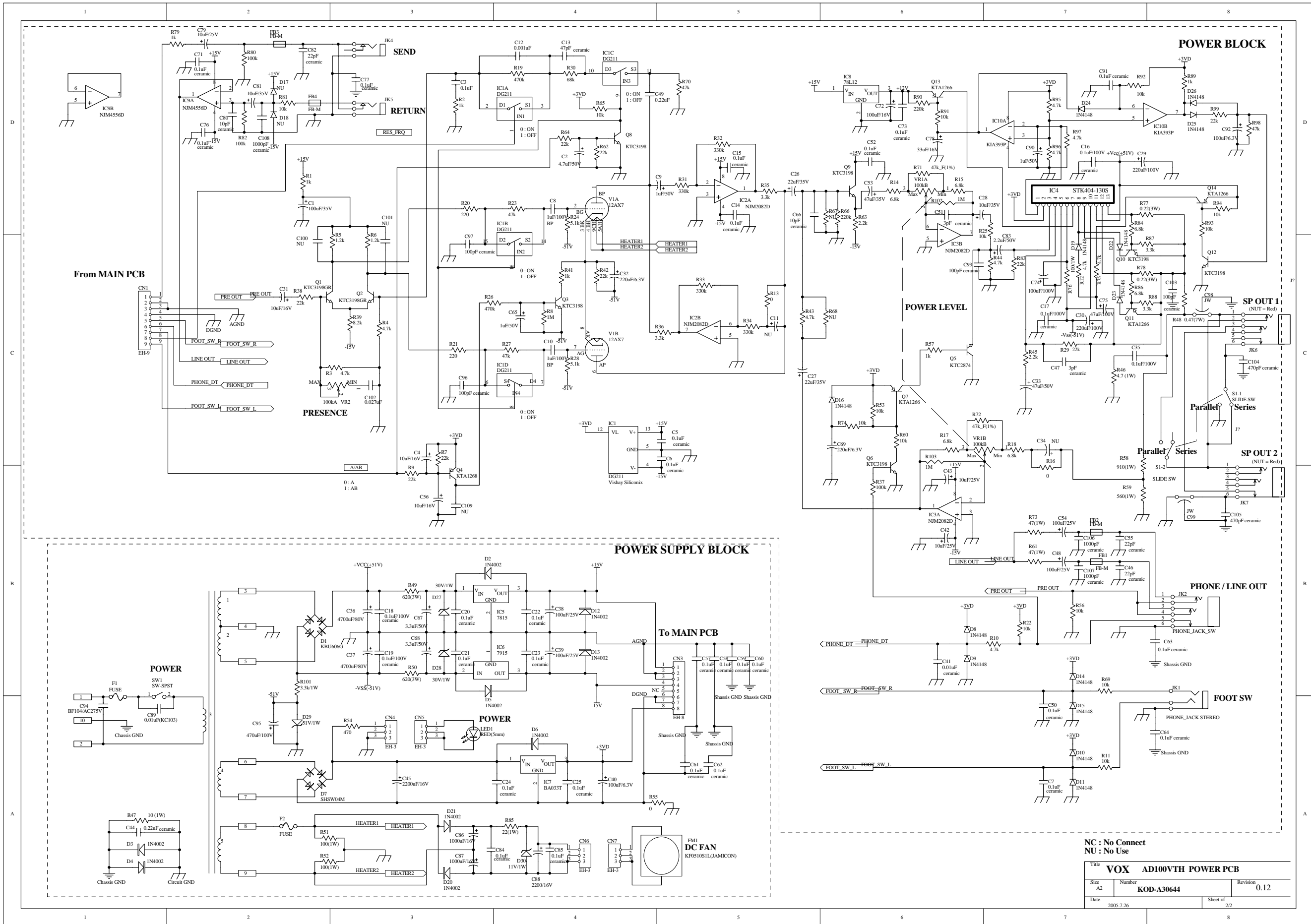

NC : No Connect
NU : No Use

Title: **VOX AD100VTH POWER PCB**
 Size A2 Number **KOD-A30644** Revision **0.12**
 Date 2005.7.26 Sheet of 2/2

AD15/30/50/100VT Test Mode

How to start the test mode

WRITE + TAP: FULL TEST (Internal Test & External Test)
TAP + BYPASS: AUDIO TEST (A/D, D/A, THRU)

note:

- Loop the PHONE/LINE and INPUT jacks with cable for the Internal Test.
- Connect a VFS-2 (foot switch) for the External Test.

Operations during the test mode

Internal test

PRESET + TAP: RE-CHECKING THE N.G. ITEMS
PRESET + BYP: SKIP THE N.G. ITEMS AND PROCEED TO THE NEXT
ITEM.

External test

MANUAL: ITEM UP
PRESET: ITEM DOWN
*With exception during the switch inspection

VOX AD100VTH Parts List

Part Code	Part Name	Note	Reference	QTY
53000000191	IC NJM2068M	MAIN PCB	IC1	1
510320511008	IC NJM4556AM	MAIN PCB	IC2	1
500324018009	IC AK4552VT-E2	MAIN PCB	IC3	1
500320011236	IC M3803-7M6H-094FP	MAIN PCB	IC4	1
500320001607	IC UPD77112GC-017-9EU	MAIN PCB	IC5	1
530000000183	IC CS18LV02563AC-70	MAIN PCB	IC6	1
530000000189	IC KIA7125FV	MAIN PCB	IC7	1
530000000180	IC AK93C45AF	MAIN PCB	IC8	1
530000000193	IC NJM2872AF	MAIN PCB	IC9	1
530000000179	IC 74LVU04DB	MAIN PCB	IC10	1
530000000178	IC 74LV4040A	MAIN PCB	IC11	1
530000000271	TR KTA2014	MAIN PCB	Q1	1
530000000276	TR KTC2875B	MAIN PCB	Q2	1
530000000159	DOUBLE DIODE DA204K	MAIN PCB	WD1,WD3	2
530000000144	CHIP INDUCTOR HH-1M2012-600	MAIN PCB	L1,L2,L3	3
530000000149	CRYSTAL 8.00MHz	MAIN PCB	X1	1
530000000148	CRYSTAL 11.2896MHz	MAIN PCB	X2	1
530000000288	VR RV160-40-15S-B10K-C0	MAIN PCB	VR1,VR4,VR5,VR6,VR7,VR8,VR9	7
530000000289	VR RV160-40-15S-B10K-C11 (11C)	MAIN PCB	VR2,VR3	2
530000000265	TACK SW ATS-1230B (K=9.5MM)	MAIN PCB	SW1,SW2,SW3,SW4,SW5,SW6	6
530000000227	PHONE JACK APJ-8P-M(NUT/BLACK)	MAIN PCB	J1	1
530000000137	BEAD CORE SAT2550L	MAIN PCB	FB1	1
530000000184	IC DG211D	POWER PCB	IC1	1
510320520503	IC NJM2082D	POWER PCB	IC2,IC3	2
530000000195	IC STK404-130s	POWER PCB	IC4	1
530000000186	IC KA7815TU(FAIRCHILD)	POWER PCB	IC5	1
530000000187	IC KA7915TU(FAIRCHILD)	POWER PCB	IC6	1
530000000181	IC BA033T	POWER PCB	IC7	1
530000000190	IC KIA78L12BP	POWER PCB	IC8	1
510320520502	IC NJM4556AD	POWER PCB	IC9	1
530000000188	IC KIA393P	POWER PCB	IC10	1
530000000277	TR KTC3198GR	POWER PCB	Q1,Q2,Q3,Q6,Q8,Q9,Q10,Q12	8
530000000268	TR KTA1266GR	POWER PCB	Q7,Q11,Q13,Q14	4
530000000270	TR KTA1268GR	POWER PCB	Q4	1
530000000273	TR KTC2874	POWER PCB	Q5	1
530000000141	BRIDGE DIODE KBU6K	POWER PCB	D1	1
530000000142	BRIDGE DIODE W04M	POWER PCB	D7	1
530000000150	D 1N4002	POWER PCB	D2,D3,D4,D5,D6,D12,D13,D20,D21	9
530000000151	D 1N4148	POWER PCB	D8,9,10,11,14,15,16,19,22,23,24,25,26	13
530000000152	D 1N4741B	POWER PCB	D30	1
530000000153	D 1N4751B	POWER PCB	D27,D28	2
530000000154	D 1N4757B	POWER PCB	D29	1
530000000249	RED LED 5M/M DLL-50231	POWER PCB	LED1	1
530000000137	BEAD CORE SAT2550L	POWER PCB	FB1,FB2,FB3,FB4	4
530000000228	PHONE JACK APJ-8P-S(NUT/BLACK)	POWER PCB	JK1,JK2	2
530000000227	PHONE JACK APJ-8P-M(NUT/RED)	POWER PCB	JK3	1
530000000229	PHONE JACK CL1120(NUT/BLACK)	POWER PCB	JK4,JK5	1
530000000230	PHONE JACK CL1124(NUT/RED)	POWER PCB	JK6,JK7	1
530000000290	VR RV162-20-15SP-B100K	POWER PCB	VR1	1
530000000285	VR RV160-20-15SP-A100K	POWER PCB	VR2	1
530000000258	SLIDE SWITCH RF-1002P6MR	POWER PCB	SW1	1
530000000174	FUSE 250V T1A L	POWER PCB	F2	1
530000000175	FUSE CLIP 0751-0110	POWER PCB	F2A,F2B	2
530000000281	TUBE SOCKET VT9-PT-2	POWER PCB	V1A	1
530000000157	DC FAN KF0510S1L	POWER PCB	FAN1	1
530000000210	MAIN PCB ASS'Y AD100VTH	Chassis	A1	1
530000000231	POWER PCB ASS'Y AD100VTH	Chassis	A2	1
530000000202	JACK PCB ASS'Y AD100VT	Chassis	A1	1
530000000282	VACUUME TUBE 12AX7EH	Chassis	V1	1
530000000237	POWER TRANS 100V= 086-ADJ	Chassis	T1	1
530000000239	POWER TRANS 120V= 086-ADU	Chassis		1
530000000241	POWER TRANS 230V= 086-ADE	Chassis		1
530000000243	POWER TRANS 240V= 086-ADEF	Chassis		1
530000000166	FUSE T3.15AL 250V	Chassis	F1(100V/120V)	1
530000000170	FUSE T1.6AL 250V	Chassis	(230V/240V)	1
530000000234	POWER SW RF1003(BB2)	Chassis	SW1	1
530000000199	INLET/FUSE HOLDER SC-8F-21	Chassis		1
530000000163	FRONT PANEL AD100VTH FPN0112-F	Chassis	FPN0112-F	1
530000000245	REAR PANEL AD100VTH (100V)	Chassis		1
530000000415	REAR PANEL AD100VTH (120V)	Chassis		1
530000000416	REAR PANEL AD100VTH (230V)	Chassis		1

Part Code	Part Name	Note	Reference	QTY
530000000417	REAR PANEL AD100VTH (240V)	Chassis		1
530000000205	KNOB ABS (CHIKEN HEAD)	Chassis		8
530000000267	TACT KNOB ABS(CIRCLE)KNOB0009-TACT	Chassis		6
530000000250	ROUND KNOB ABS	Chassis		3
530000000206	LED BUSHING	Chassis		1
530000000280	TUBE COVER NBR 31PIE	Chassis		1
530000000255	SHIELD PLATE SPTE 0.3T PRE0004	Chassis	PRE0004	1
530000000253	RUBBER FOOT SBR60	Chassis		1
530000000200	JACK NUT BLACK ABS M11	Chassis		5
530000000201	JACK NUT(RED) ABS	Chassis		2
530000000292	WOODEN CABINET AD100VTH	Set	CABINET ASSY	1
530000000313	HANDLE ASS'Y	Set		1
530000000138	BRAND MARK VOX (LARGE) SILVER	Set		1
530000000160	EMBLEM VALVETRONICS SILVER	Set		1
530000000263	SPEAKER GRILL AD100VTH	Set		1
530000000251	RUBBER FOOT SBR LARGE	Set		4
530000000147	CORNER NYLON 6/6 D-VOX	Set		8
530000000254	SCREW CAP ABS	Set		6
530000000283	VENT GRILL ABS	Set		3
530000000122	AC CORD 100V = TEM-M055-0011	Packing		1
530000000123	AC CORD 120V = KKP30-16A	Packing		1
530000000124	AC CORD 230V = KKP4819R-16A	Packing		1
530000000125	AC CORD 230V = KKP650-16A	Packing		1
530000000126	AC CORD 240V = KKP550-16A	Packing		1
530000000226	MONO CABLE 1500MM	Packing		2