

WEBCOR

A-1944

A-1945

A-1946

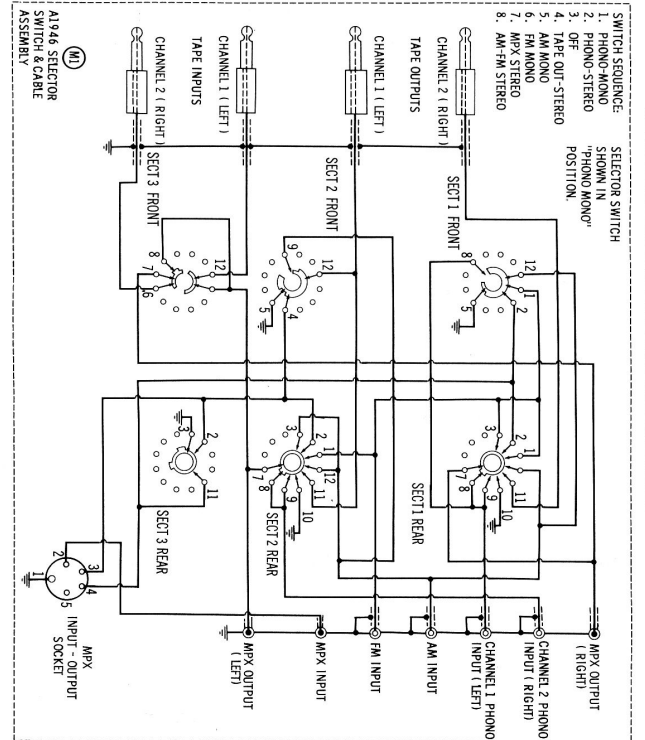
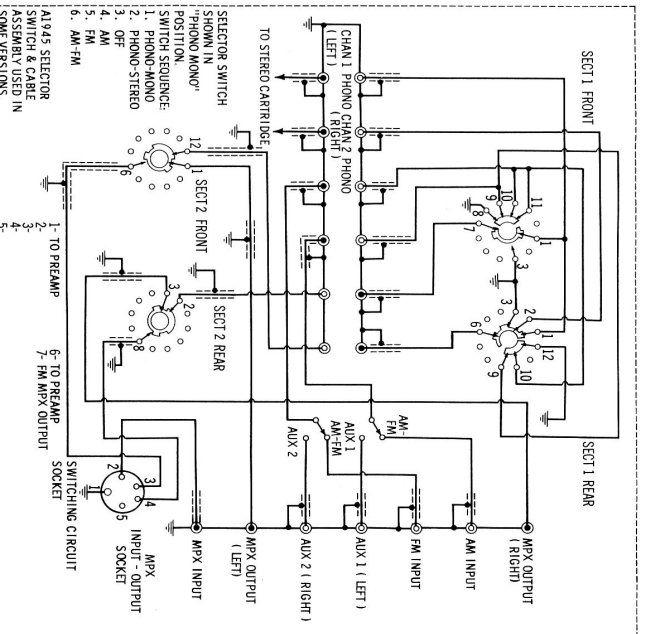
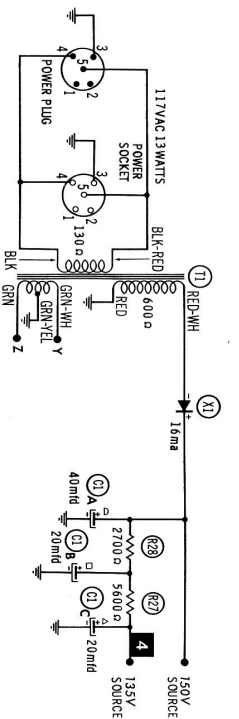

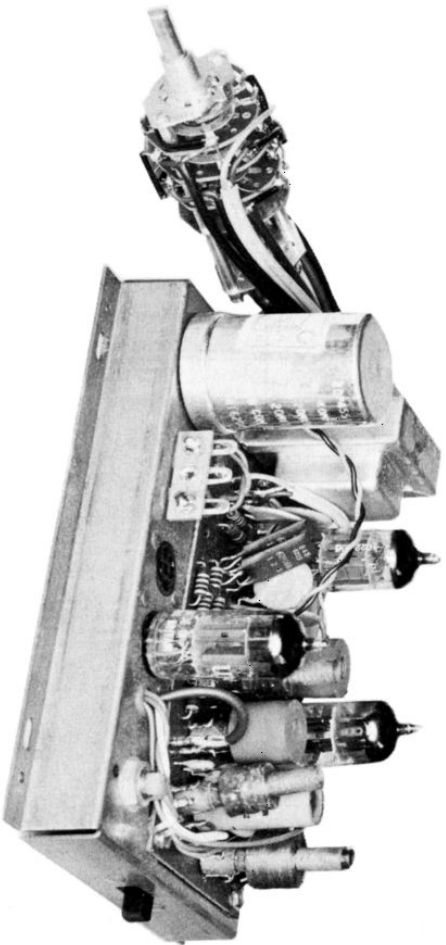

Webcor A-1944, A-1945 A-1946 Alignment Data

Ch. 73X031-1

MULTIPLEX ALIGNMENT USING FM STEREO GENERATOR & AUDIO OSCILLATOR

SIGNAL GENERATOR	CONNECT SCOPE	ADJUST	REMARKS
1. 19KC to MPX input, low side to chassis.	Vert. amp. thru 47K to pin 7, V1, low side to chassis.	A1	Adjust for maximum
2. "	Vert. amp. to point A , low side to chassis.	A2	"
3. 67KC to MPX input, low side to chassis.	"	A3	Adjust for MINIMUM
4. "	"	A4	Adjust for maximum
5. 20KC to point B , low side to chassis.	Vert. amp. to point C , low side to chassis.	A5	Adjust for maximum