

STEREO INTEGRATED AMPLIFIER

A-40/A-45

SERVICE MANUAL

IMPORTANT NOTICE

This manual has been provided for the use of authorized Yamaha Retailers and their service personnel. It has been assumed that basic service procedures inherent to the industry, and more specifically Yamaha Products, are already known and understood by the users, and have therefore not been restated.

WARNING: Failure to follow appropriate service and safety procedures when servicing this product may result in personal injury, destruction of expensive components and failure of the product to perform as specified. For these reasons, we advise all Yamaha product owners that all service required should be performed by an authorized Yamaha Retailer or the appointed service representative.

IMPORTANT: The presentation or sale of this manual to any individual or firm does not constitute authorization, certification or recognition of any applicable technical capabilities, or establish a principle-agent relationship of any form.

The data provided is believed to be accurate and applicable to the unit(s) indicated on the cover. The research, engineering, and service departments of Yamaha are continually striving to improve Yamaha products. Modifications are, therefore, inevitable and specifications are subject to change without notice or obligation to retrofit. Should any discrepancy appear to exist, please contact the distributor's Service Division.

WARNING: Static discharges can destroy expensive components. Discharge any static electricity your body may have accumulated by grounding yourself to the ground buss in the unit (heavy gauge black wires connect to this buss).

IMPORTANT: Turn the unit OFF during disassembly and parts replacement. Recheck all work before you apply power to the unit.

CONTENTS

TO SERVICE PERSONNEL	1	ADJUSTMENTS	8
INTERNAL VIEW	1	IC DATA	9 ~ 10
A-40 PANELS & REMOTE CONTROL		INTERCONNECT WIRING DIAGRAM	11
TRANSMITTER	2	A-40 PRINTED CIRCUIT BOARD	12 ~ 16
A-45 PANELS & REMOTE CONTROL		A-45 PRINTED CIRCUIT BOARD	17 ~ 21
TRANSMITTER	3	A-40 SCHEMATIC DIAGRAM	22
A-40 SPECIFICATIONS	4	A-45 SCHEMATIC DIAGRAM	23
A-45 SPECIFICATIONS	5	A-40 PARTS LIST	24 ~ 30
A-40 BLOCK DIAGRAM	6	A-45 PARTS LIST	31 ~ 37
A-45 BLOCK DIAGRAM	7	REMOTE CONTROL TRANSMITTER	38
DISASSEMBLY PROCEDURES	8		

TO SERVICE PERSONNEL

1. Critical Components Information.
Components having special characteristics are marked Δ and must be replaced with parts having specifications equal to those originally installed.
2. Leakage Current Measurement (For 120V Model Only).
When service has been completed, it is imperative that you verify that all exposed conductive surfaces are properly insulated from supply circuits.
 - Meter impedance should be equivalent to 1500 ohm shunted by 0.15 μ F
 - Leakage current must not exceed 0.5mA.
 - Be sure to test for leakage with the AC plug in both polarities.

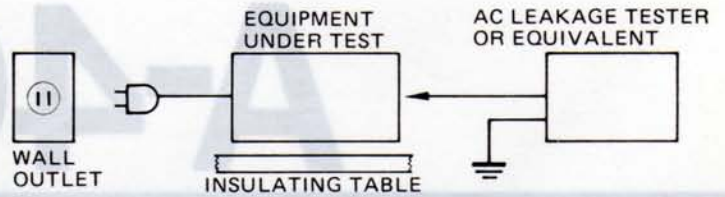

• POLARIZATION (U, C models only)

This amplifier product is equipped with a polarized alternating current line plug (a plug having one blade wider than the other). This plug will fit into the power outlet only one way. This is a safety feature.

INTERNAL VIEW

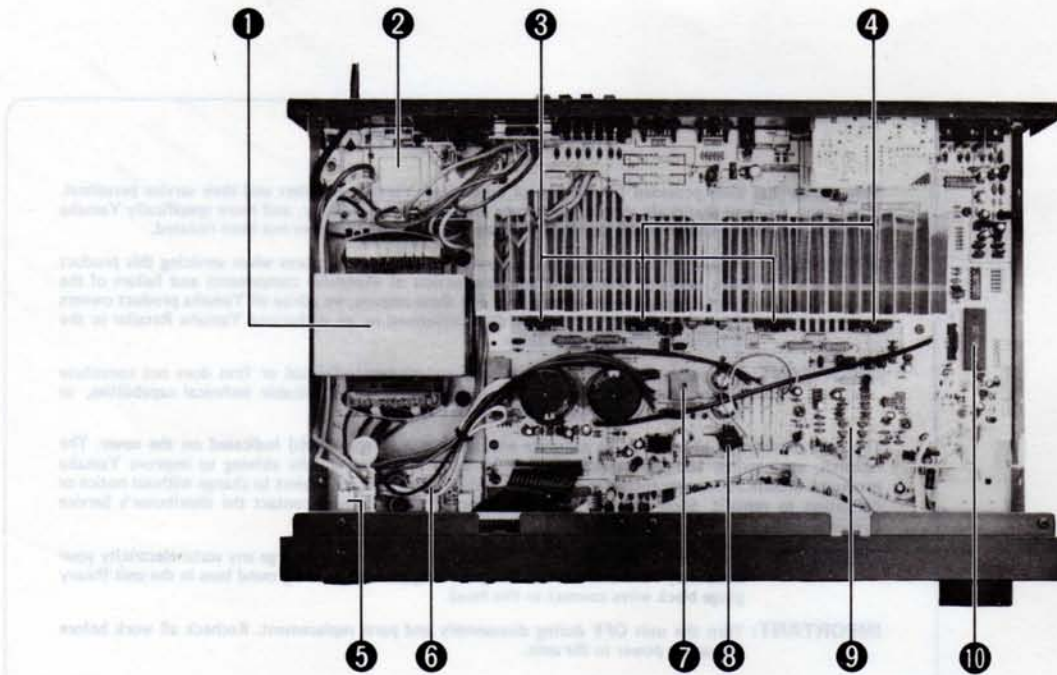

- 1 POWER TRANSFORMER
- 2 Sub Circuit Board (3)
- 3 POWER TRANSISTOR
- 4 POWER TRANSISTOR
- 5 POWER SWITCH

- 6 MAIN CIRCUIT BOARD (4)
- 7 DIODE BRIDGE: 4D4B41
- 8 DIODE BRIDGE: 2B4B41
- 9 MAIN CIRCUIT BOARD (1)
- 10 4bit μ -COM: LC6505C-3525

CONTENTS

TO SERVICE PERSONNEL

INTERNAL VIEW

A-40 PANELS & REMOTE CONTROL

A-45 PANELS & REMOTE CONTROL

TRANSMITTER

A-40 SPECIFICATIONS

A-45 SPECIFICATIONS

A-40 BLOCK DIAGRAM

A-45 BLOCK DIAGRAM

DISASSEMBLY PROCEDURES

■ A-40 PANELS & REMOTE CONTROL TRANSMITTER

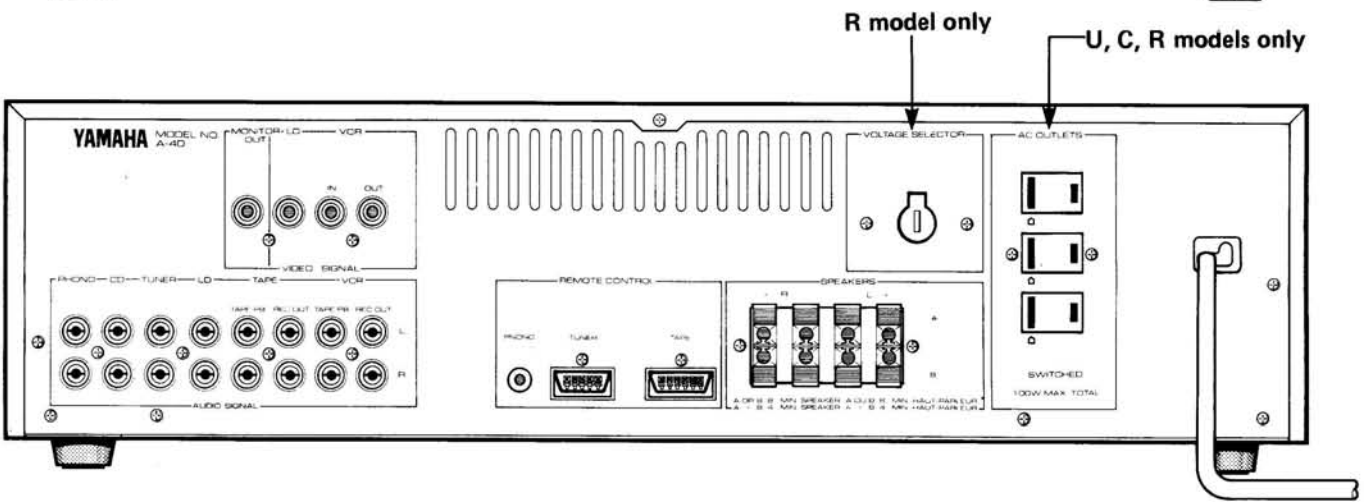
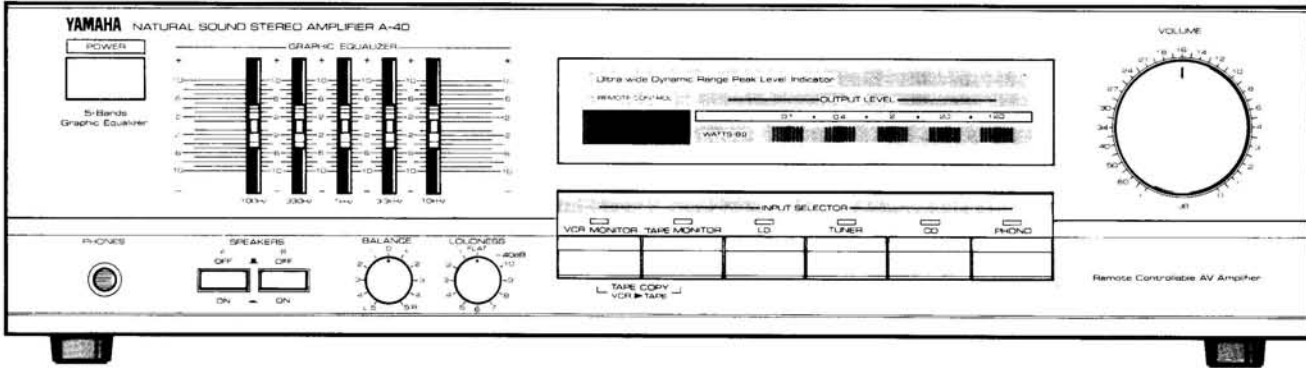

R model only

U, C, R models only

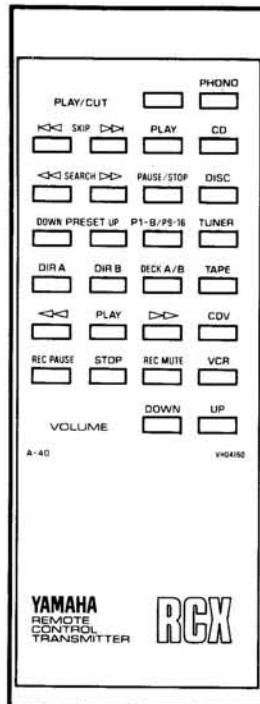

■ A-45 PANELS & REMOTE CONTROL TRANSMITTER

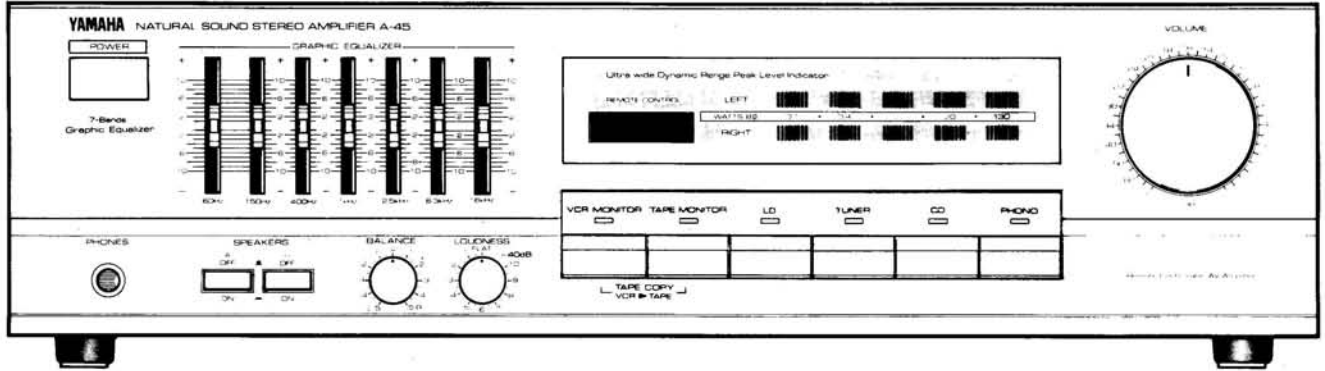

R model only

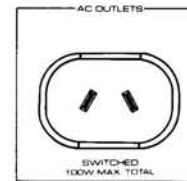
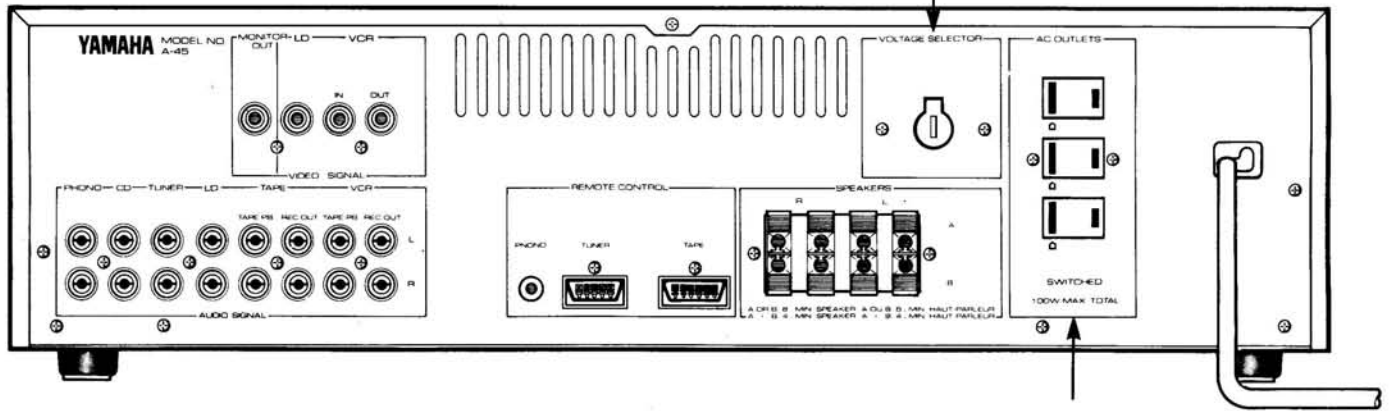

A model only

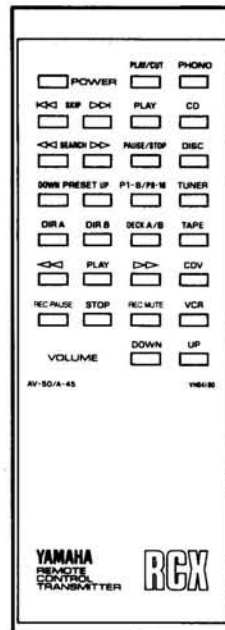

■ A-40 SPECIFICATIONS

■ AUDIO SECTION

Minimum RMS Output Power per Channel

8Ω, 20Hz ~ 20kHz, 0.05% THD	105W (U, C)/ 100W (R, A, B)/ 80W (G)
8Ω, 1kHz, 0.1% THD	115W

Dynamic Power per Channel

(IHF, 8Ω)	145W/120W (G)
(IHF, 6Ω)	180W/150W (G)
(IHF, 4Ω)	240W/190W (G)

DIN Standard Output Power per Channel

1kHz, 1% THD, 4Ω	115W (G)
------------------	----------

Dynamic Headroom

8Ω	1.6dB
----	-------

IEC Power

1kHz, 0.01% THD, 8Ω	85W (G)
---------------------	---------

Power Band Width

0.1% THD, 50W, 8Ω	10 Hz ~ 60kHz
-------------------	---------------

Damping Factor

(8Ω, 1kHz)	50
------------	----

Input Sensitivity/Impedance

PHONO MM	2.5mV/47kΩ
CD etc	150mV/47kΩ

Input Sensitivity (New IHF)

Phono MM	0.25mV
CD etc	15mV

Maximum Input Signal (1kHz, 0.02% THD)

PHONO MM	80mV
----------	------

Output Level/Impedance

REC OUT	150mV/470Ω
---------	------------

Headphone Jack Rated Output/Impedance

0.05% THD, RL = 8Ω	0.81V/270Ω
	0.73V/270Ω (G)

Frequency Response (20Hz ~ 20kHz)

CD etc	±0.5dB
--------	--------

RIAA Equalization Deviation

PHONO MM	±0.5dB
----------	--------

Total Harmonic Distortion (20Hz ~ 20kHz)

PHONO MM to REC OUT, 3V	0.009%
CD etc to Sp OUT, 50W/8Ω	0.02%

Signal to Noise Ratio (IHF-A Network)

PHONO MM (5mV Input Shorted)	79dB
CD etc (Shorted)	100dB

Signal to Noise Ratio (New IHF)

PHONO MM	75dB
CD etc	80dB

Input Equivalent Noise

125dBV (A) (B) (G)

Residual Noise (IHF-A Network)

250μV

Channel Separation (1kHz Vol. -30dB)

PHONO MM Input Shorted	70dB
CD etc Input 5.1kΩ Terminated	70dB

Graphic Equalizer

Control Frequency	100Hz, 330Hz, 1kHz, 3.3kHz, 10kHz
Boost/Cut	±12dB

Continuous Loudness Control

(Level related equalization)	
Attenuation	-20dB (1kHz)

Gain Tracking Error (0 to -60dB)

2dB

■ GENERAL

Power Supply

General Model	110/120/220/240V, 50/60Hz
Australian and British models	240V, 50Hz
European model	220V, 50Hz
U.S.A. and Canadian models	120V, 60Hz

Power Consumption

U, C, R models	340W
A, B, G models	400W

AC Outlets

Switched x 3 (U, R, C)	100W max. (Total)
------------------------	-------------------

Dimensions (W x H x D)

435 x 122.5 x 300.5 mm
(17-1/8" x 4-7/8" x
11-13/16")

Weight

6.9 kg (15 lb 3 oz)

* Specifications are subject to change without notice.

(C) Canadian Model

(A) Australian Model

(U) U.S.A. Model

(R) General Model

(B) British Model

(G) European Model

● Dimensions

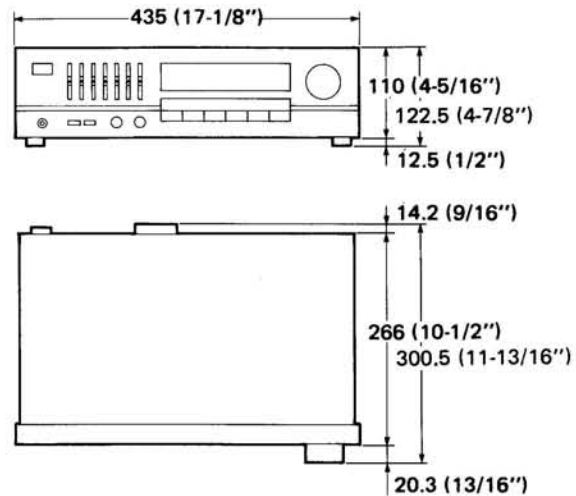

Unit: mm (inch)

■ A-45 SPECIFICATIONS

■ AUDIO SECTION

Minimum RMS Output Power per Channel	
8Ω, 20Hz ~ 20kHz, 0.05% THD	115W (R)/ 120W (U, C, A)
8Ω, 1kHz, 0.1% THD	130W
Dynamic Power per Channel	
(1HF, 8Ω)	160W
(1HF, 6Ω)	205W
(1HF, 4Ω)	270W
Power Band Width	
0.1% THD, 60W, 8Ω	10Hz ~ 60kHz
Dynamic Headroom	
8Ω	1.43dB
Damping Factor	
(8Ω, 1kHz)	50
Input Sensitivity/Impedance	
PHONO MM	2.5mV/47kΩ
CD etc	150mV/47kΩ
Input Sensitivity (New IHF)	
PHONO MM	0.25mV
CD etc	15mV
Maximum Input Signal (1kHz, 0.02% THD)	
PHONO MM	80mV
Output Level/Impedance	
REC OUT	150mV/470Ω
Headphone Jack Rated Output/Impedance	
0.05% THD, RL = 8Ω	0.87V/270Ω
Frequency Response (20Hz ~ 20kHz)	
CD etc	±0.5dB
RIAA Equalization Deviation	
PHONO MM	±0.5dB
Total Harmonic Distortion (20Hz ~ 20kHz)	
PHONO MM to REC OUT, 3V	0.009%
CD etc to Sp OUT, 50W/8Ω	0.02%
Signal to Noise Ratio (IHF-A Network)	
PHONO MM (5mV Input Shorted)	79dB
CD etc (Shorted)	100dB
Signal to Noise Ratio (New IHF)	
PHONO MM	75dB
CD etc	80dB
Input Equivalent Noise	
	125dBV (A)
Residual Noise (IHF-A Network)	
	250μV
Channel Separation (1kHz Vol. -30dB)	
PHONO MM Input Shorted	70dB
CD etc Input 5.1kΩ Terminated	70dB
Graphic Equalizer	
Control Frequency	60Hz, 150Hz, 400Hz, 1kHz, 2.5kHz, 6.3kHz, 16kHz
Boost/Cut	±12dB

Continuous Loudness Control

(Level related equalization)	
Attenuation	-20dB (1kHz)

Gain Tracking Error (0 to -60dB)	2dB
---	-----

■ GENERAL

Power Supply	
General Model	110/120/220/240V, 50/60Hz

Australian Model	240V, 50Hz
U.S.A. and Canadian Models	120V, 60Hz

Power Consumption	
U, C, R models	340W
A model	450W

AC Outlets	
Switched x 3 (U, R, C)	100W max. (Total)
Switched x 1 (A)	100W max.

Dimensions (W x H x D)	435 x 122.5 x 300.5 mm (17-1/8" x 4-7/8" x 11-13/16")
-------------------------------	---

Weight	7.5kg (16 lb 9 oz)
---------------	--------------------

* Specifications are subject to change without notice.

(C) Canadian Model
(A)..... Australian Model
(U) U.S.A Model
(R) General Model

● Dimensions

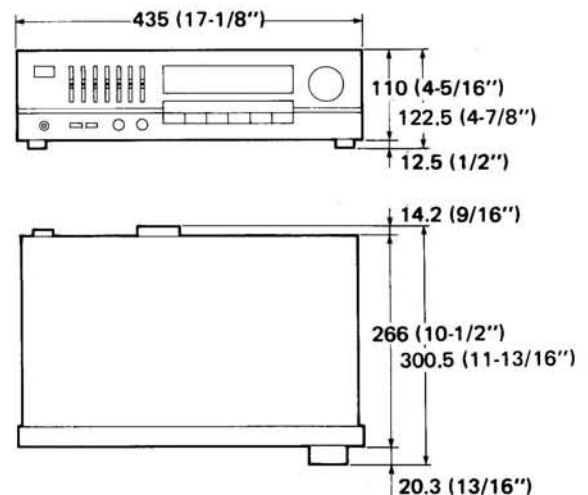

Unit: mm (inch)

A-40 BLOCK DIAGRAM

A-45 BLOCK DIAGRAM

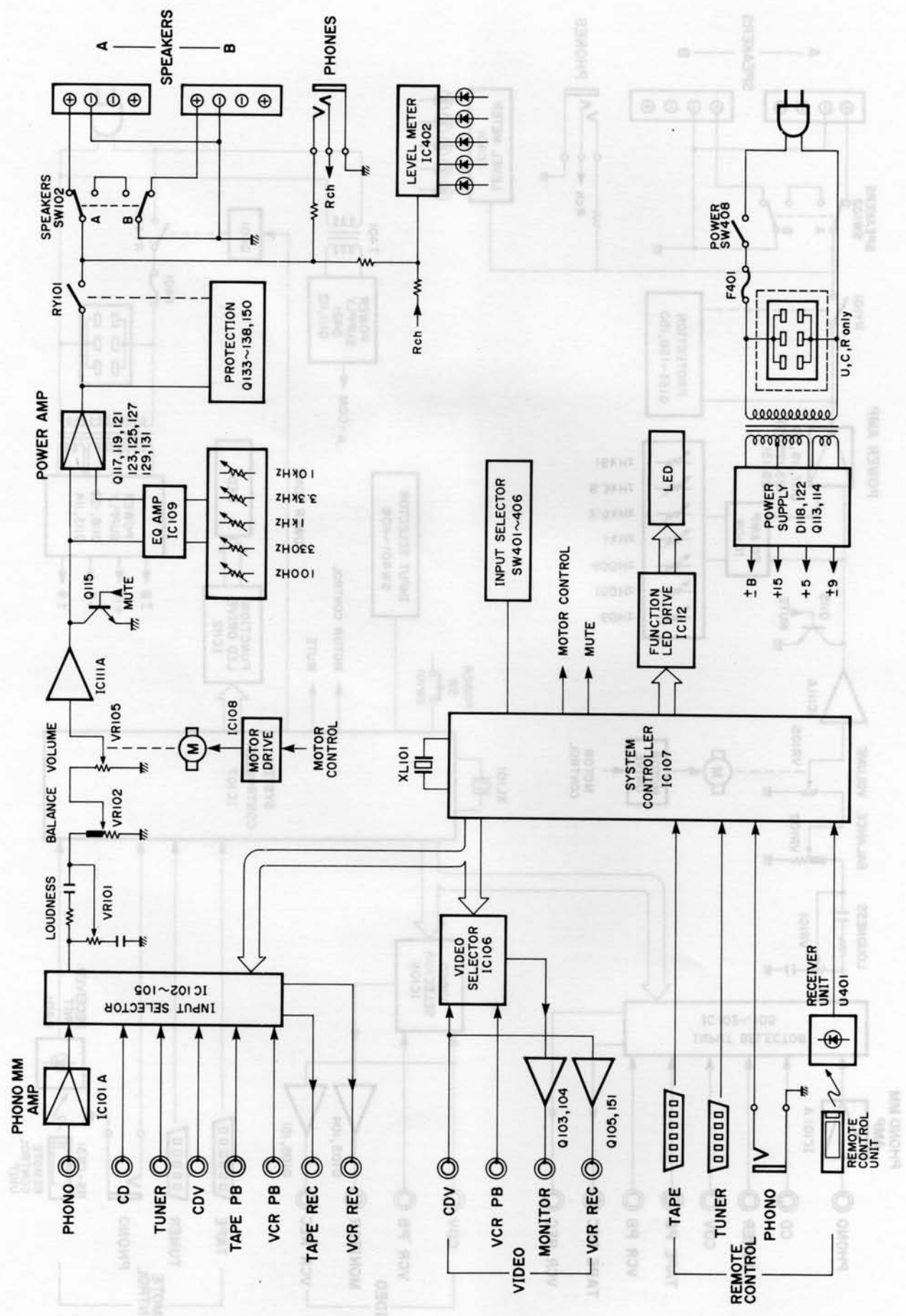

A-45 BLOCK DIAGRAM

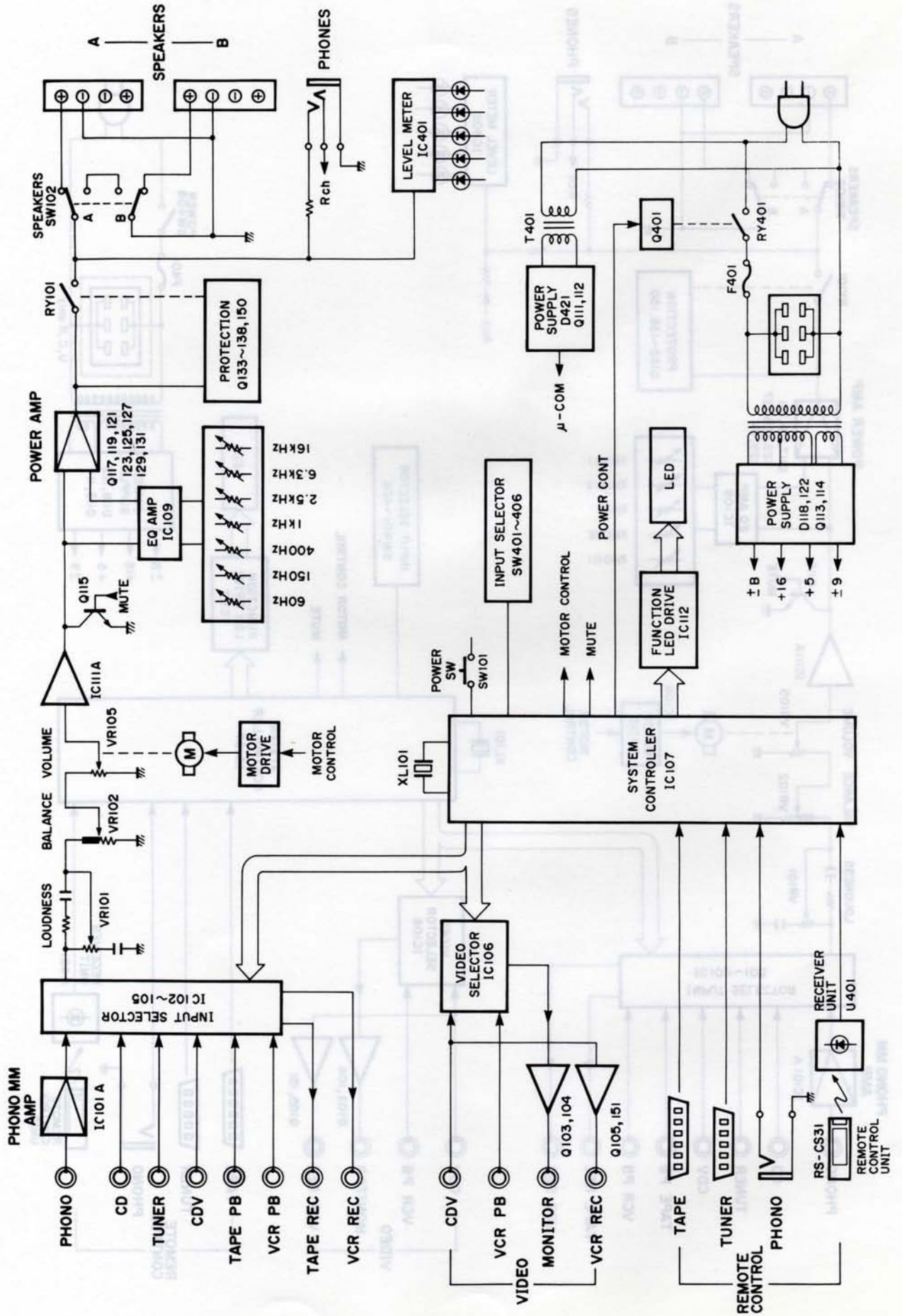

DISASSEMBLY PROCEDURES

1. Removal of Top Cover

Remove 5 screws (①) in Fig. 1, and slide the Top Cover back.

2. Removal of Front Panel

Remove 6 screws (②) in Fig. 1, and pull the Front Panel forward.

3. Removal of Bottom Cover

Remove 4 screws (③) in Fig. 1.

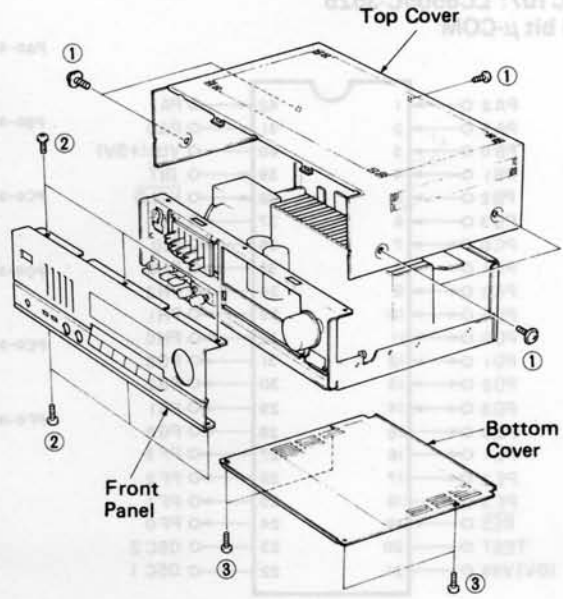

Fig. 1

ADJUSTMENTS

● IDLING CURRENT ADJUSTMENT

When replacing the power and drive transistors, adjust idling current. After the power has been turned on, age about 5 minutes in non loaded condition. Adjust VR103 (Lch) and VR104 (Rch) so that the voltage across the terminals of R253 and R254 come to 1mV ~ 2mVDC.

	Test points	Adjustment points	Rating
Lch	Across the terminals of R253	VR103	1mV ~ 2mV DC.
Rch	Across the terminals of R254	VR104	1mV ~ 2mV DC.

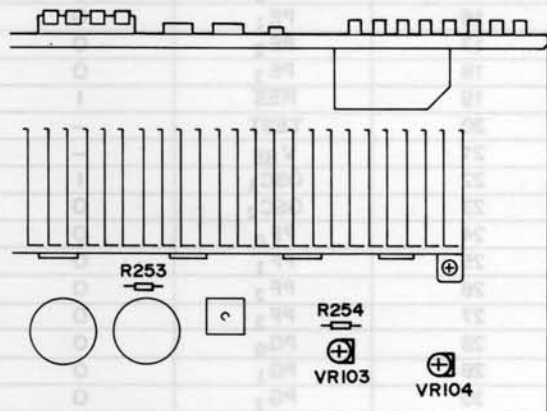

IC DATA

IC107: LC6505C-3525
4 bit μ -COM

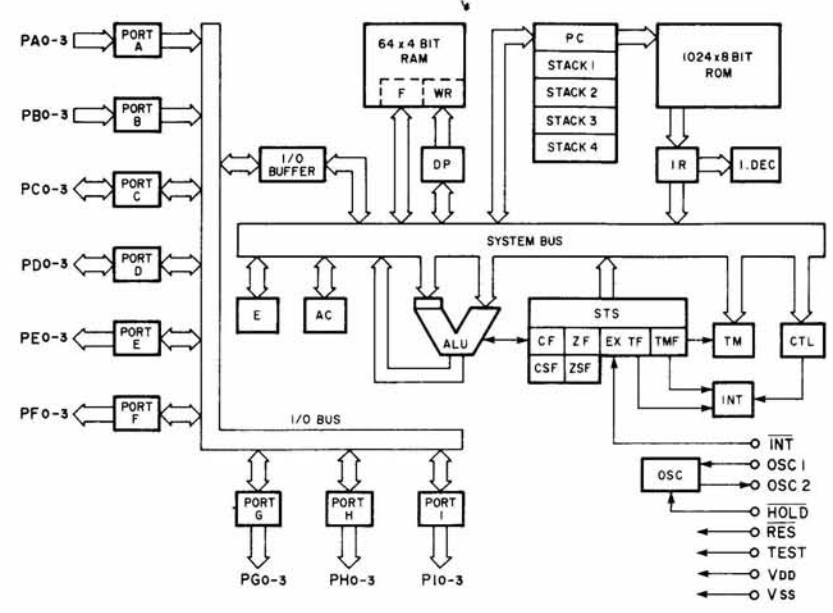
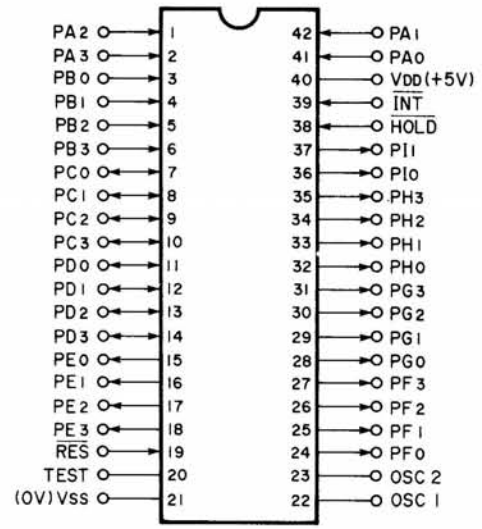

Pin No.	NAME	I/O	FUNCTION
1	PA ₂	I	Not used
2	PA ₃	I	H level
3	PB ₀	I	Key input (H: ON)
4	PB ₁	I	
5	PB ₂	I	
6	PB ₃	I	
7	PC ₀	I/O	Key scan signal (H: Active)
8	PC ₁	I/O	
9	PC ₂	I/O	
10	PC ₃	I/O	PLO PHONO PLAY/CUT Control signal
11	PD ₀	I/O	Not used
12	PD ₁	I/O	CD control signal
13	PD ₂	I/O	
14	PD ₃	I/O	
15	PE ₀	O	Deck control signal
16	PE ₁	O	
17	PE ₂	O	
18	PE ₃	O	
19	RES	I	Reset input
20	TEST	-	LSI test terminal (GND)
21	V _{SS}	-	GND
22	OSC ₁	I	μ -COM clock circuit 400kHz
23	OSC ₂	O	
24	PF ₀	O	Function control (H: ON, L: OFF)
25	PF ₁	O	
26	PF ₂	O	
27	PF ₃	O	
28	PG ₀	O	
29	PG ₁	O	
30	PG ₂	O	Not used
31	PG ₃	O	Power control signal (H: ON)
32	PH ₀	O	Volume Up control signal
33	PH ₁	O	Volume Down control signal
34	PH ₂	O	Tuner control signal
35	PH ₃	O	
36	PI ₀	O	AMUTE Audio Muting control signal (L: Active)
37	PI ₁	O	MUTE Muting control signal (L: Active)
38	HOLD	I	μ -COM Back up control (L: Back up, H: Active)
39	INT	I	+5V
40	V _{DD}	-	+5V
41	PA ₀	I	Remote control Data input
42	PA ₁	I	Power ON/OFF back up (H: Back up, L: Ever ON)

IC101, 111: M5218L (V)
Dual Op-Amp

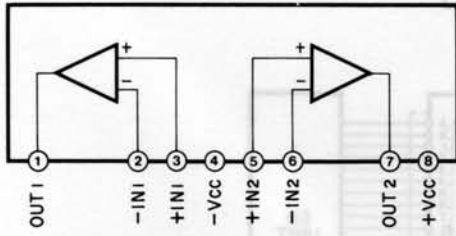

IC109, 110: M5226P
Equalizer Amp

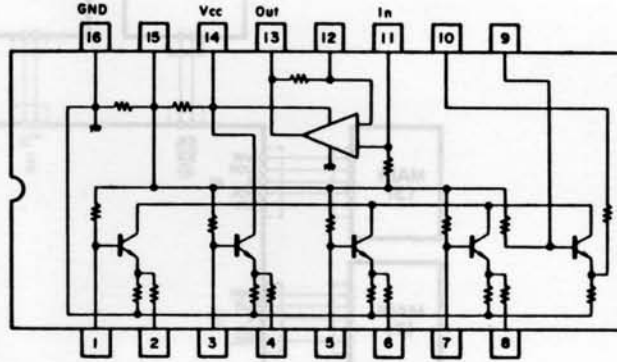

IC102 ~ 106: LC4066B, μ PD4066BC, M4066BP, MN4066B
or BU4066B
Quad Bilateral Switch

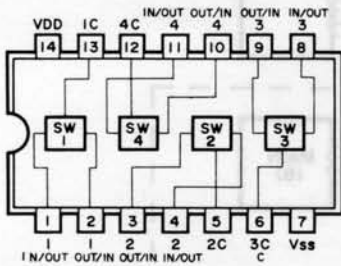

IC112: LB1294
LED Drive

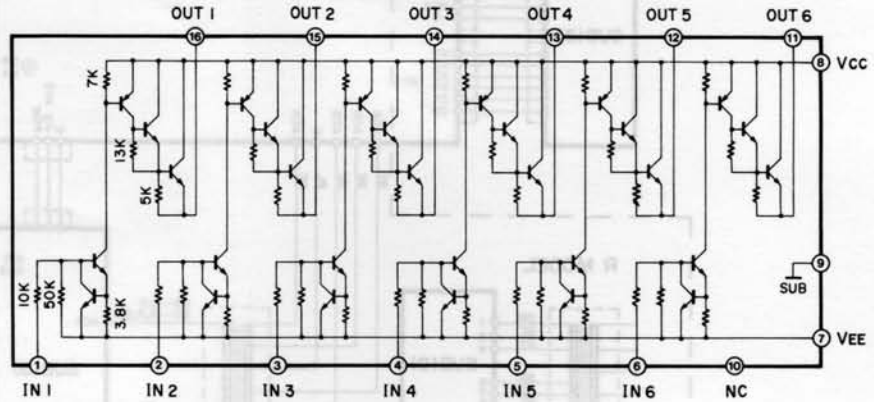

IC108: M54542
Motor Drive

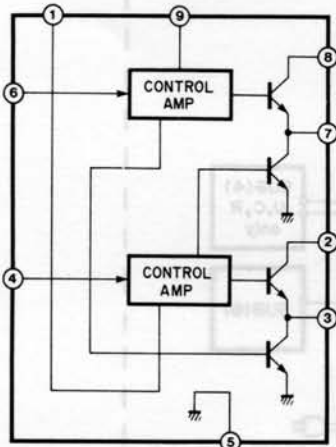

IC401, 402: BA6144
Level Meter Drive

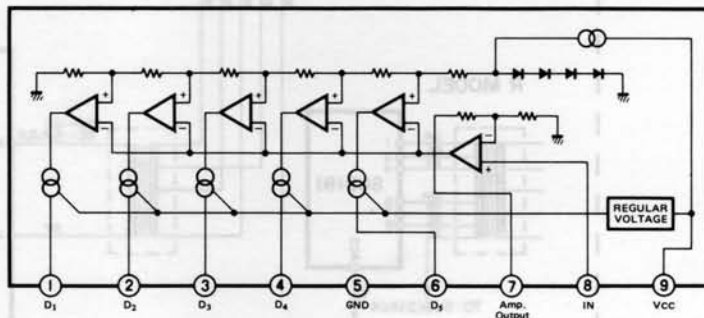

INTERCONNECT WIRING DIAGRAM

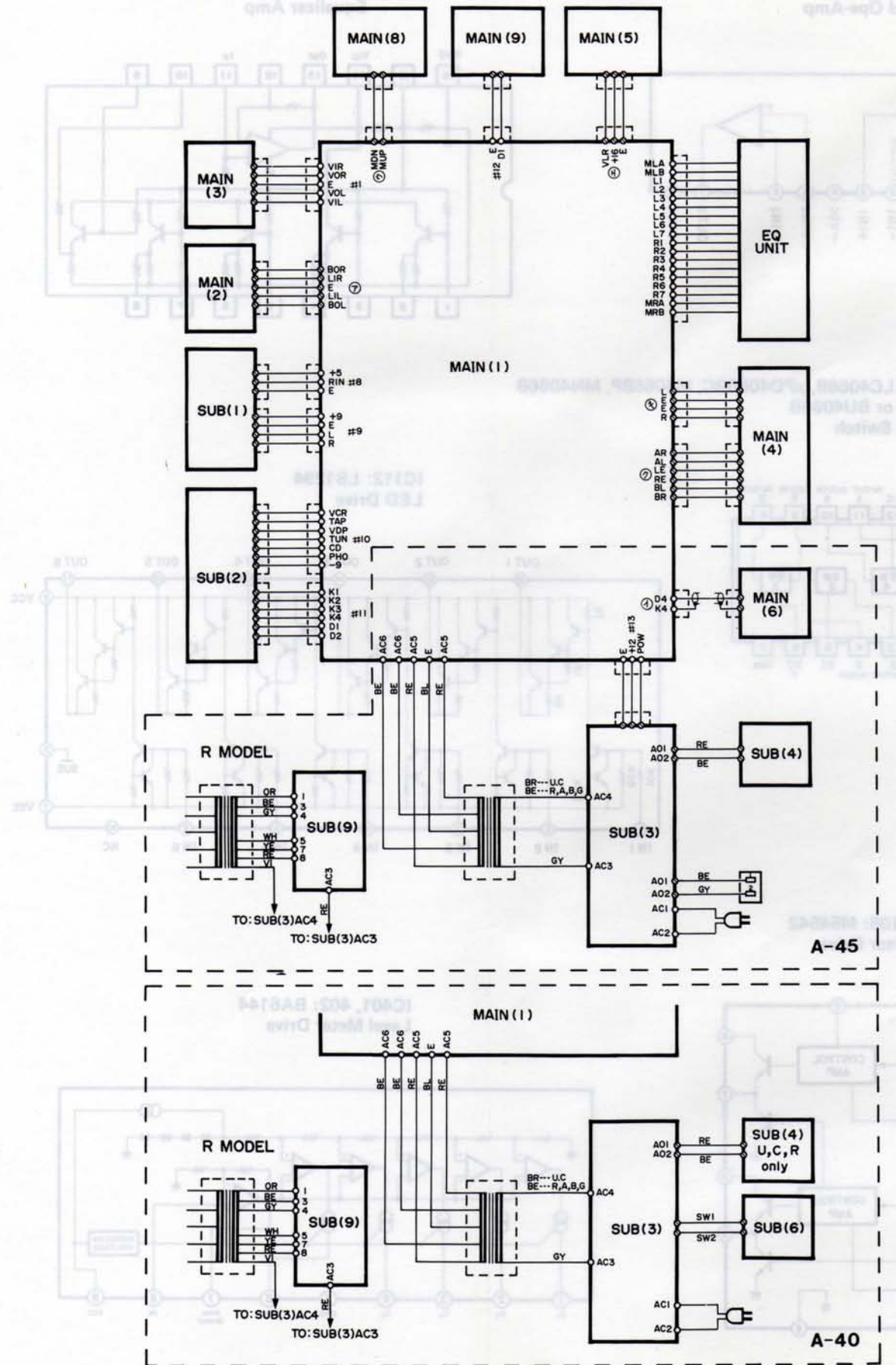

A-45

A-40

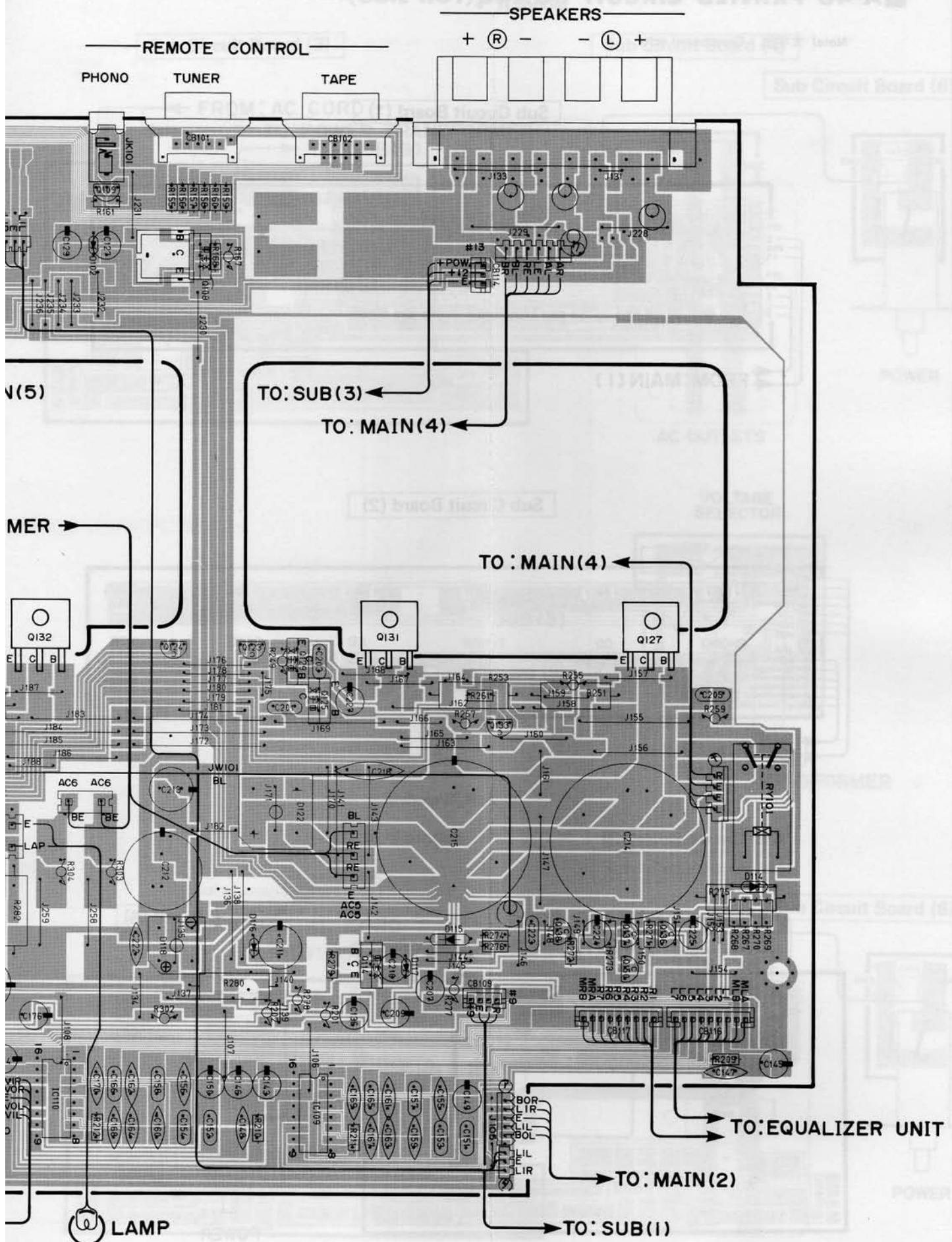

A-40 PRINTED CIRCUIT BOARD (Foil side)

Note) 文字面 : Component side

Sub Circuit Board (1)

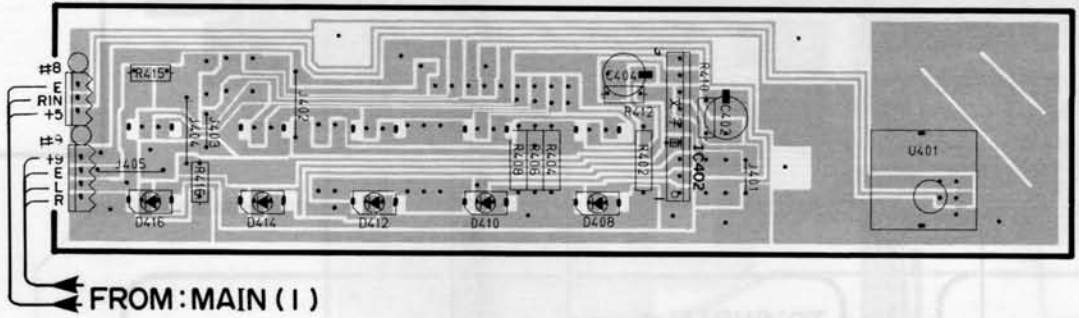

Sub Circuit Board (2)

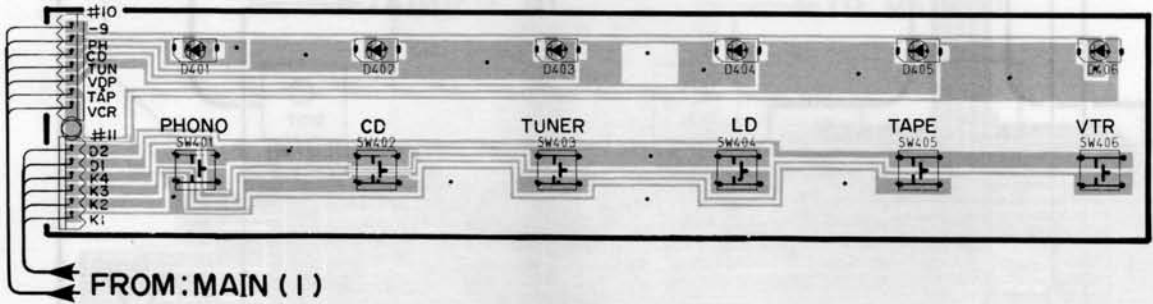

• A, B, G models

Sub Circuit Board (3)

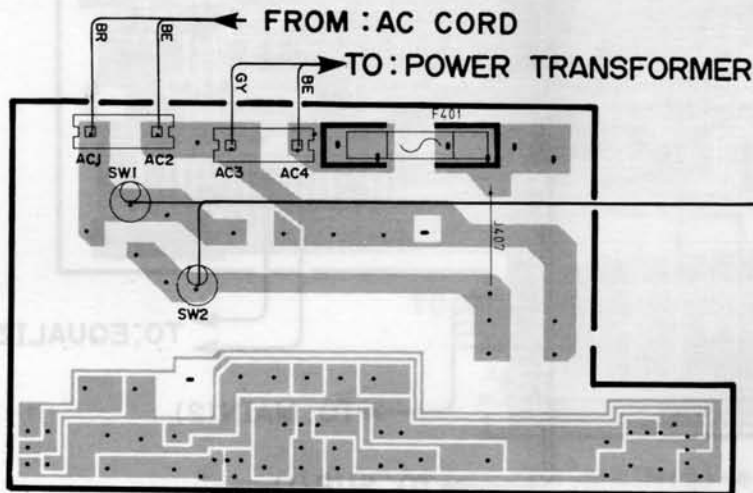

Sub Circuit Board (6)

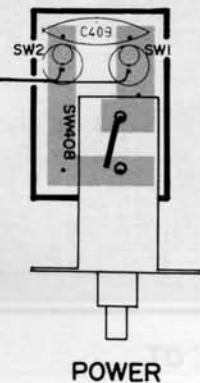

• R model

Sub Circuit Board (3)

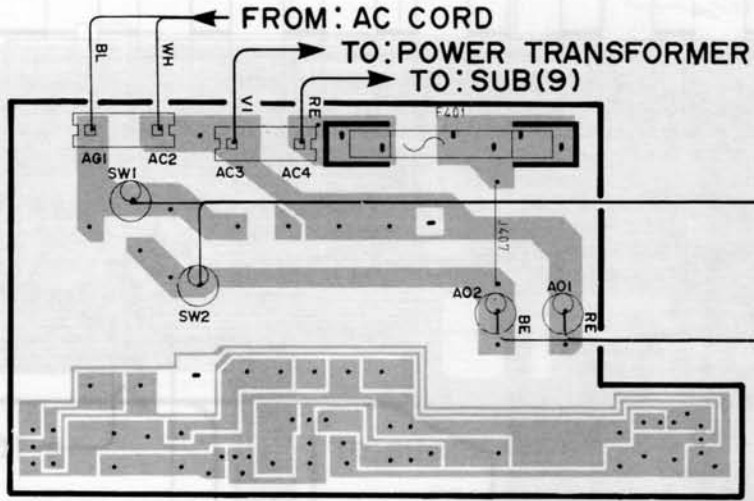

Sub Circuit Board (4)

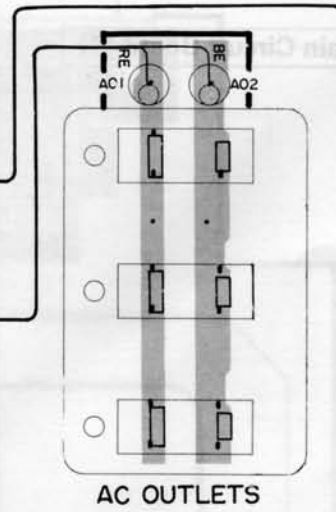

Sub Circuit Board (6)

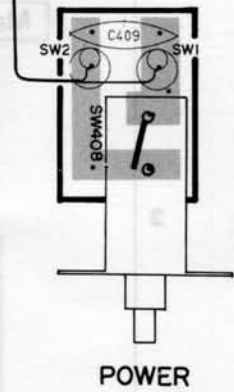

FROM:
SUB (3)

Sub Circuit Board (9)

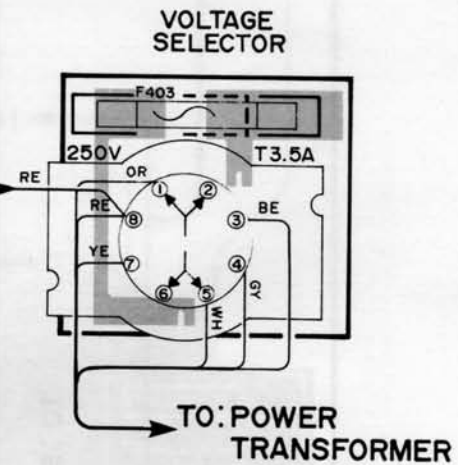

• U, C models

Sub Circuit Board (3)

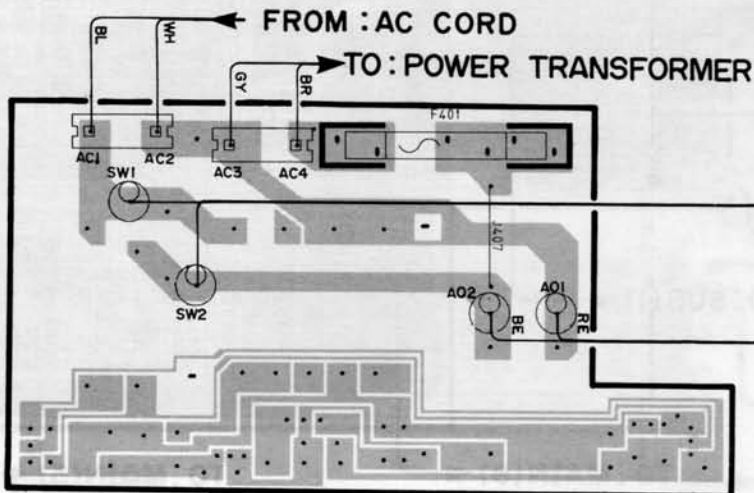

Sub Circuit Board (4)

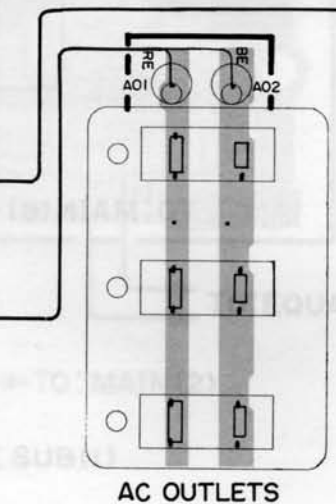

Sub Circuit Board (6)

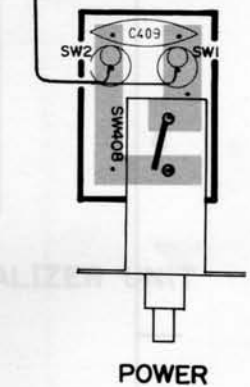

1 ■ A-40 PRINTED CIRCUIT BOARD (Foil side)

Main Circuit Board (2)

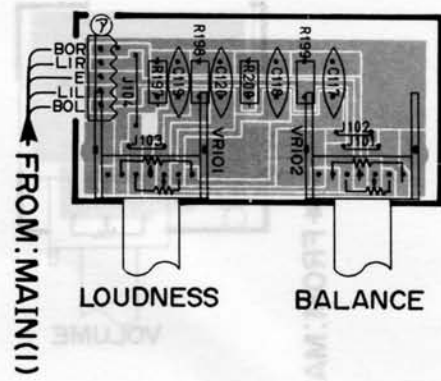

Main Circuit Board (3)

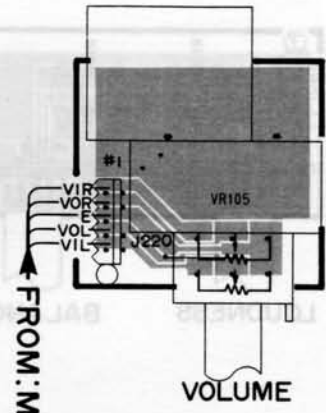

Main Circuit Board (4)

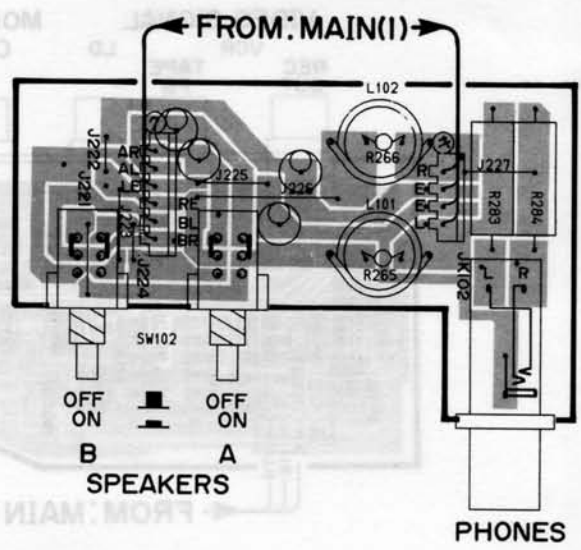

Main Circuit Board (5)

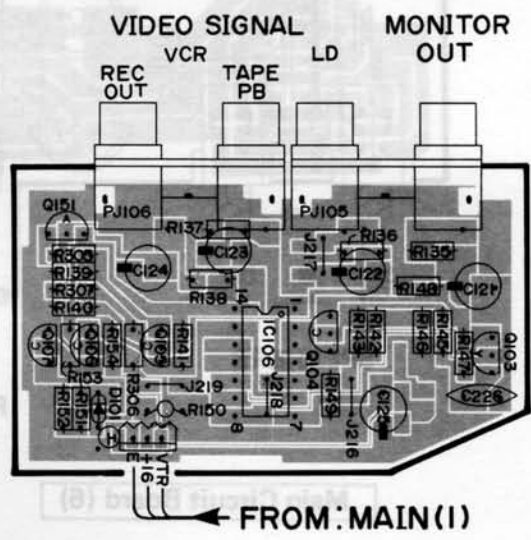

A-45 PRINTED CIRCUIT BOARD (Foil side)

Main Circuit Board (2)

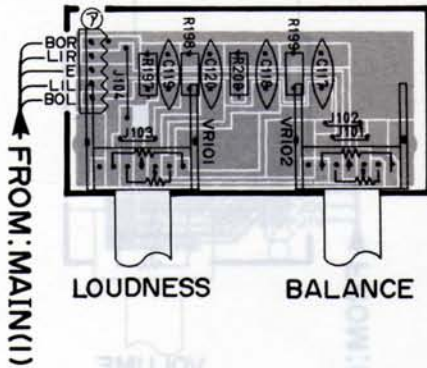

Main Circuit Board (3)

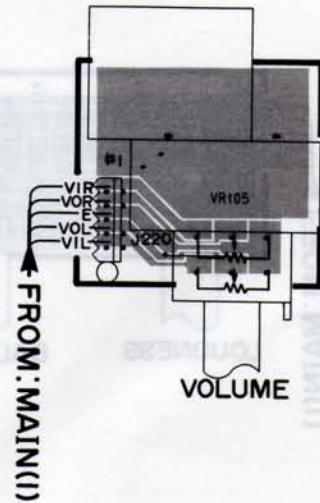

Main Circuit Board (4)

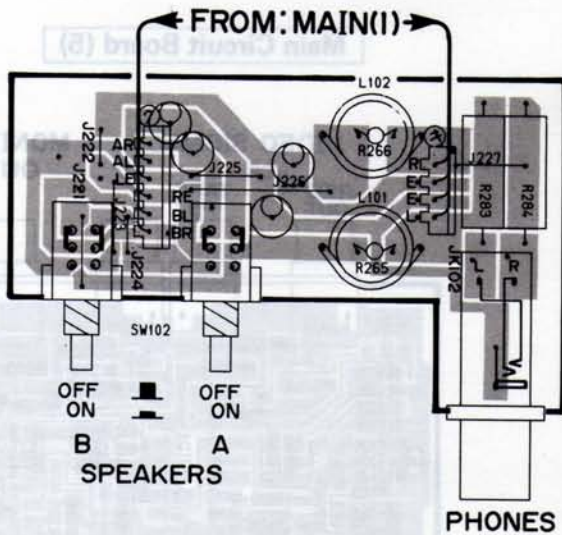

Main Circuit Board (5)

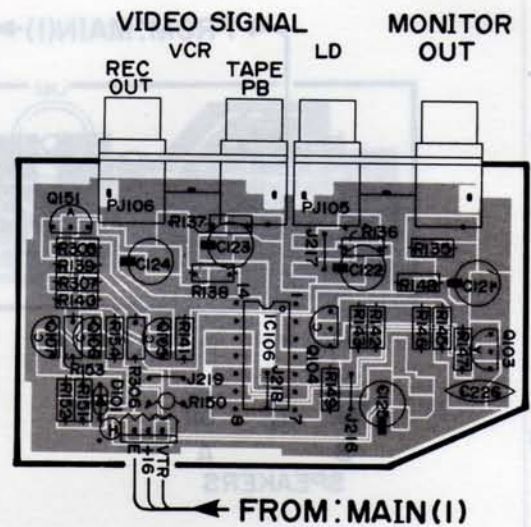

Main Circuit Board (6)

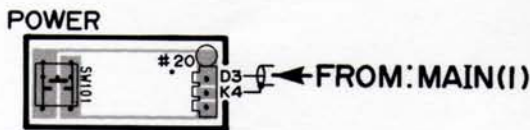

Main Circuit Board (8)

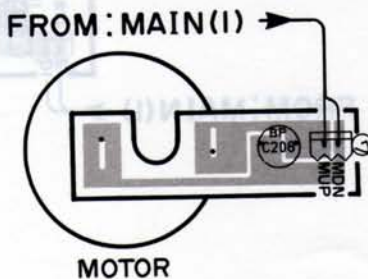

Main Circuit Board (9)



A-45 PRINTED CIRCUIT BOARD (Foil side)

Main Circuit Board (1)

- 1
- 2
- 3
- 4
- 5
- 6

PHONO CD TUNER LD TAPE TAPE VCR
PB REC PB REC

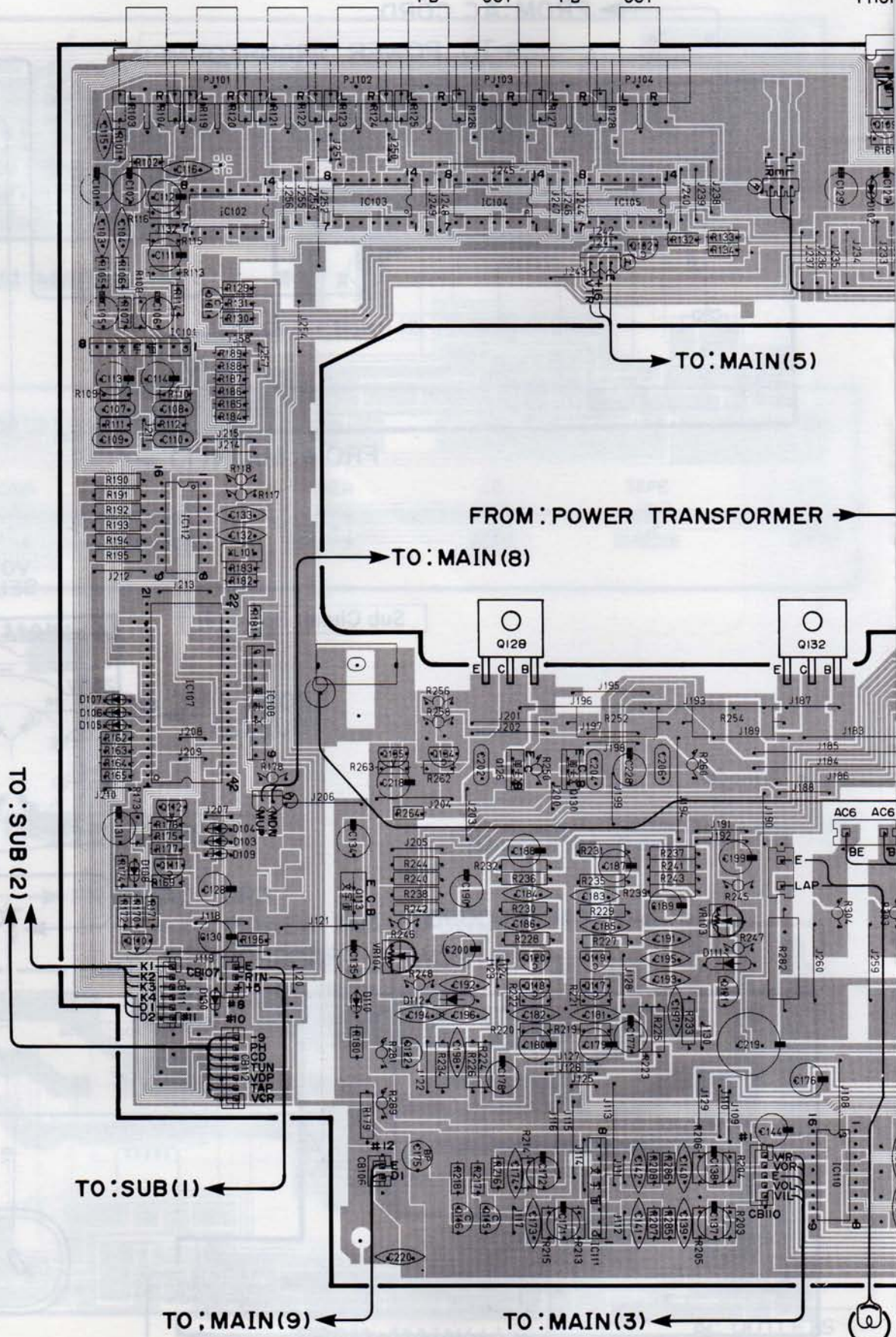

SPEAKERS

REMOTE CONTROL

TUNER

TAPE

+ (R) - - (L) +

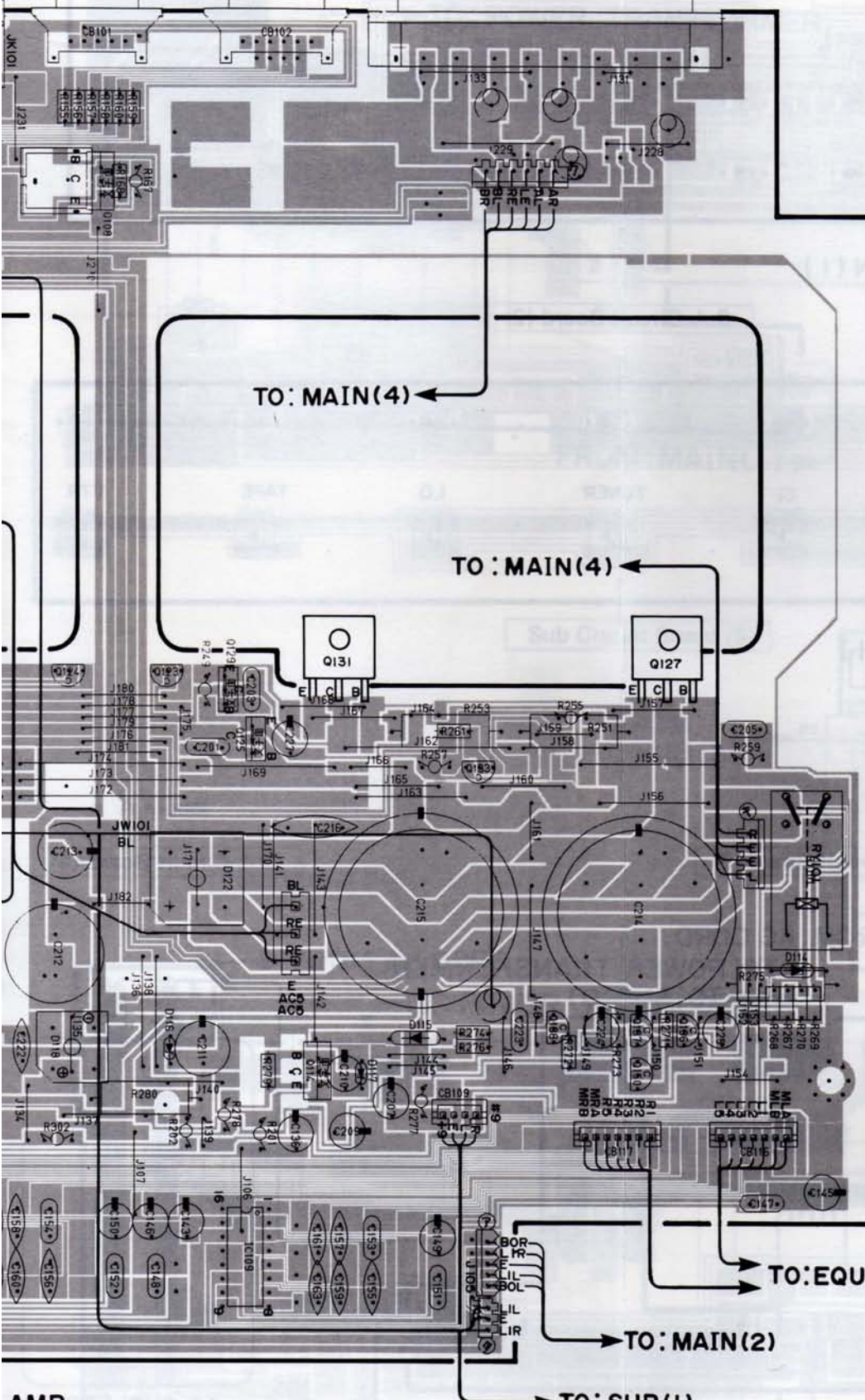

AMP

A-45 PRINTED CIRCUIT BOARD (Foil side)

Sub Circuit Board (1)

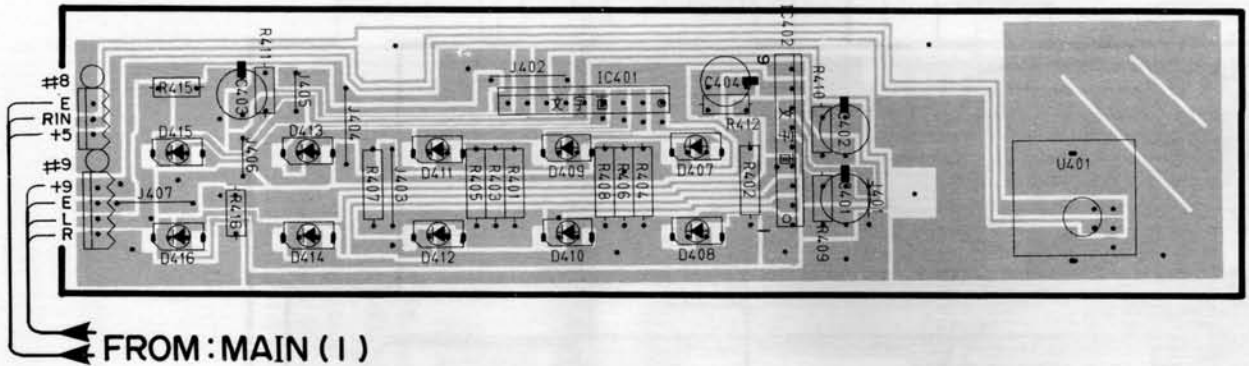

Sub Circuit Board (2)

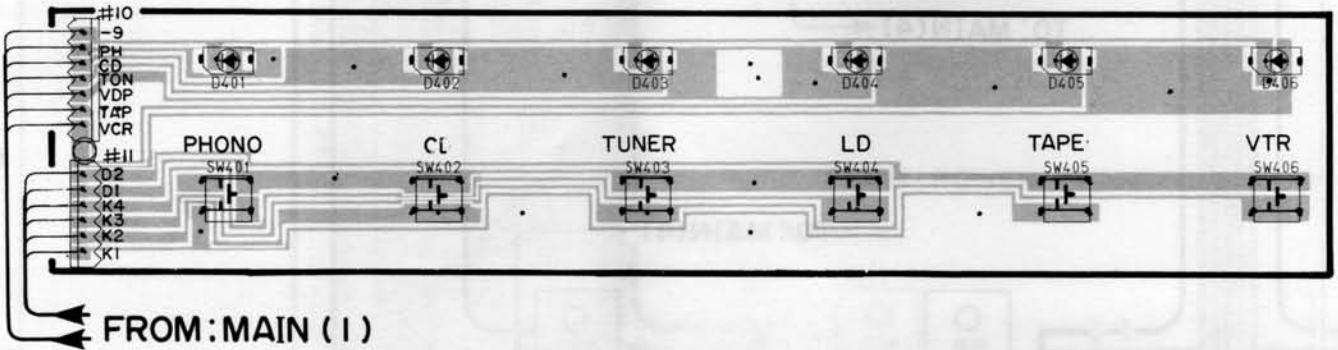

• R model

Sub Circuit Board (3)

Sub Circuit Board (4)

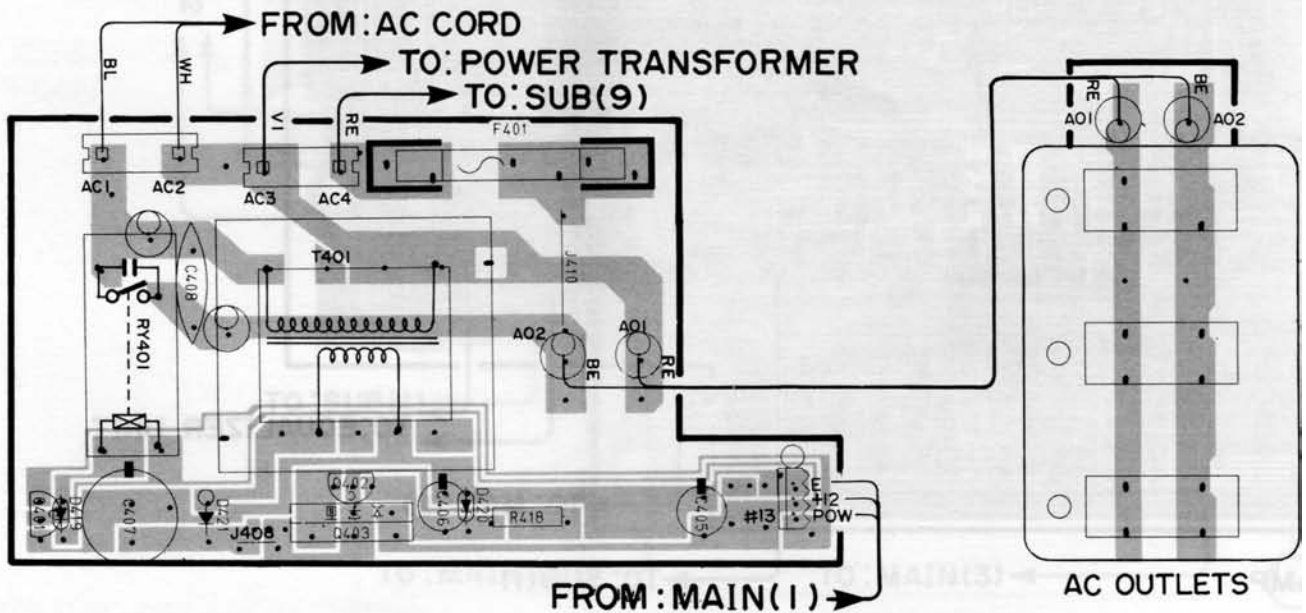

AC OUTLETS

• U, C models

Sub Circuit Board (3)

Sub Circuit Board (4)

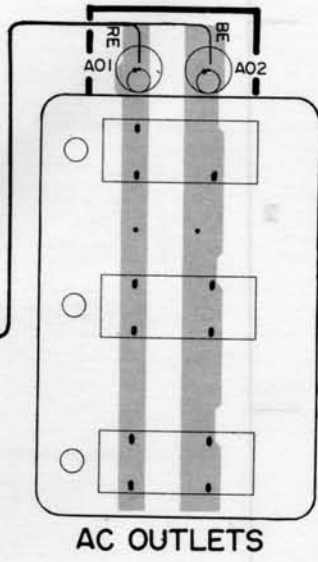
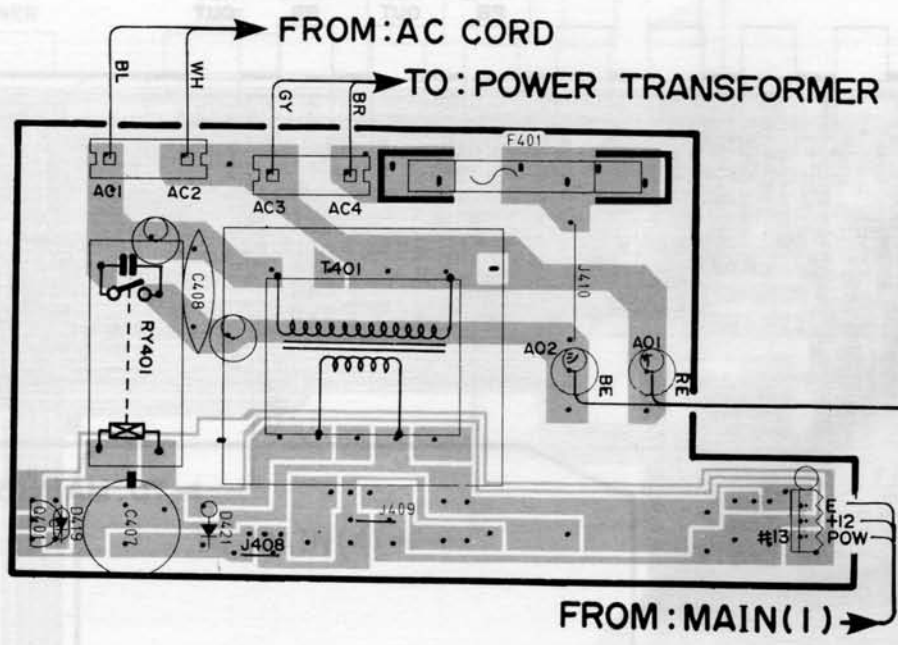

• A model

Sub Circuit Board (9)

VOLTAGE SELECTOR

FROM: SUB (3)

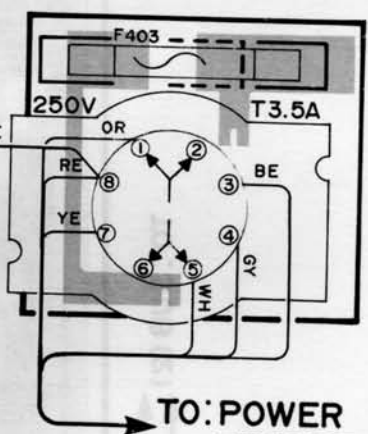

Sub Circuit Board (3)

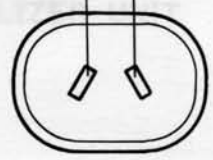
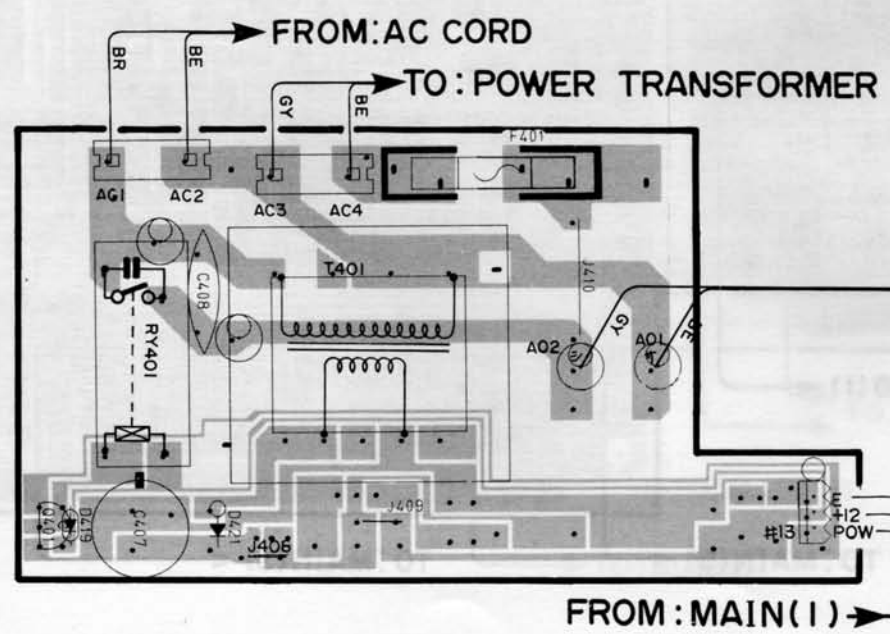

A-40 SCHEMATIC DIAGRAM

1
2
3
4
5
6

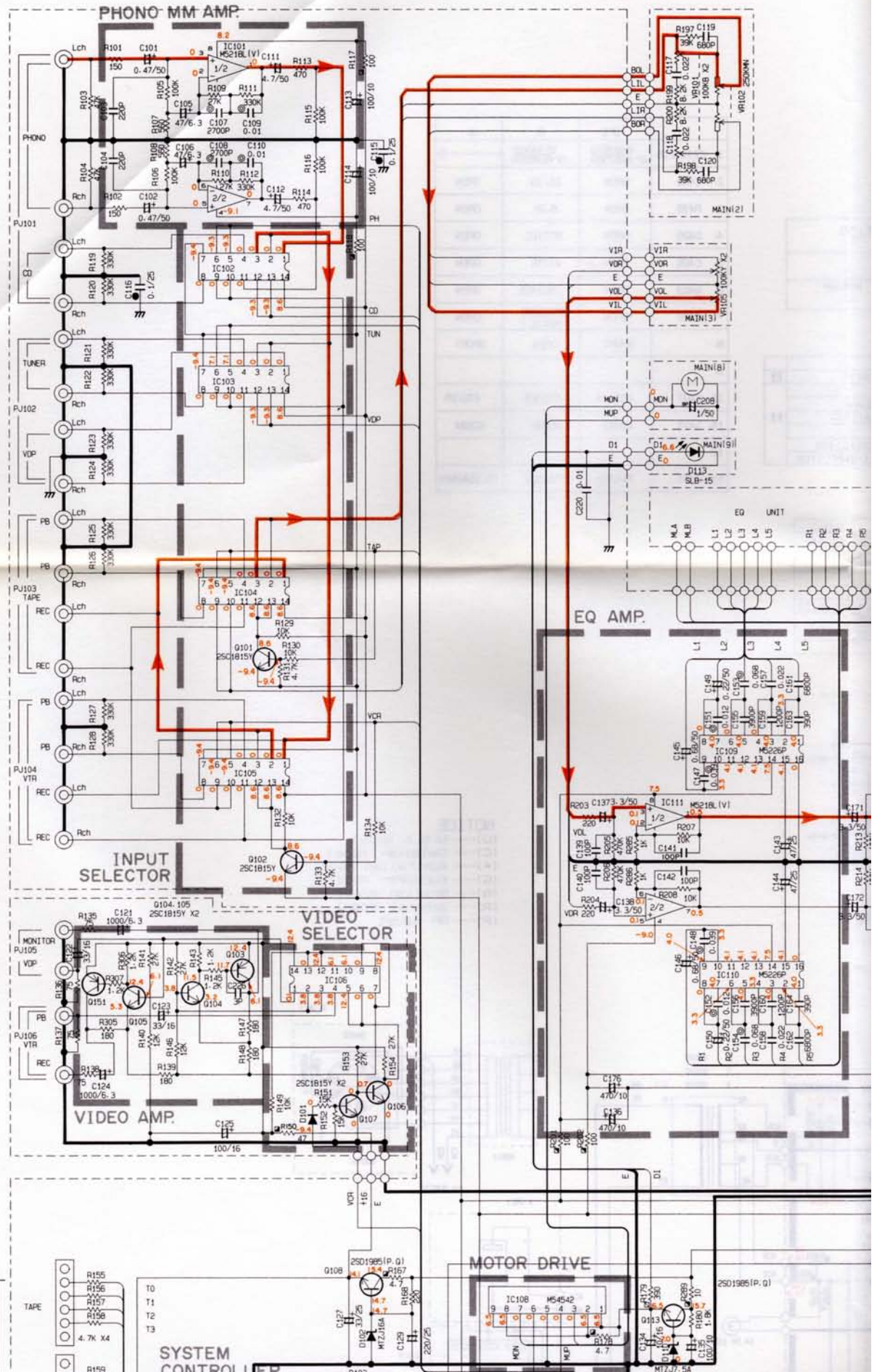

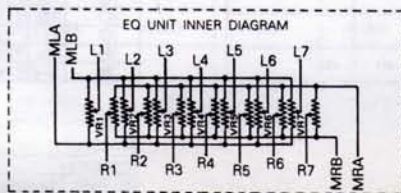

		U-C	R.A.B
#1	R275	2P1.5K	
#2	Q131 Q132	2SA1301(R.O)	
#3	Q127 Q128	2SC3280(R.O)	
#4	R231 R232	27K	
#5	C214 C215	12000/71	8200/71

POWER AMP.

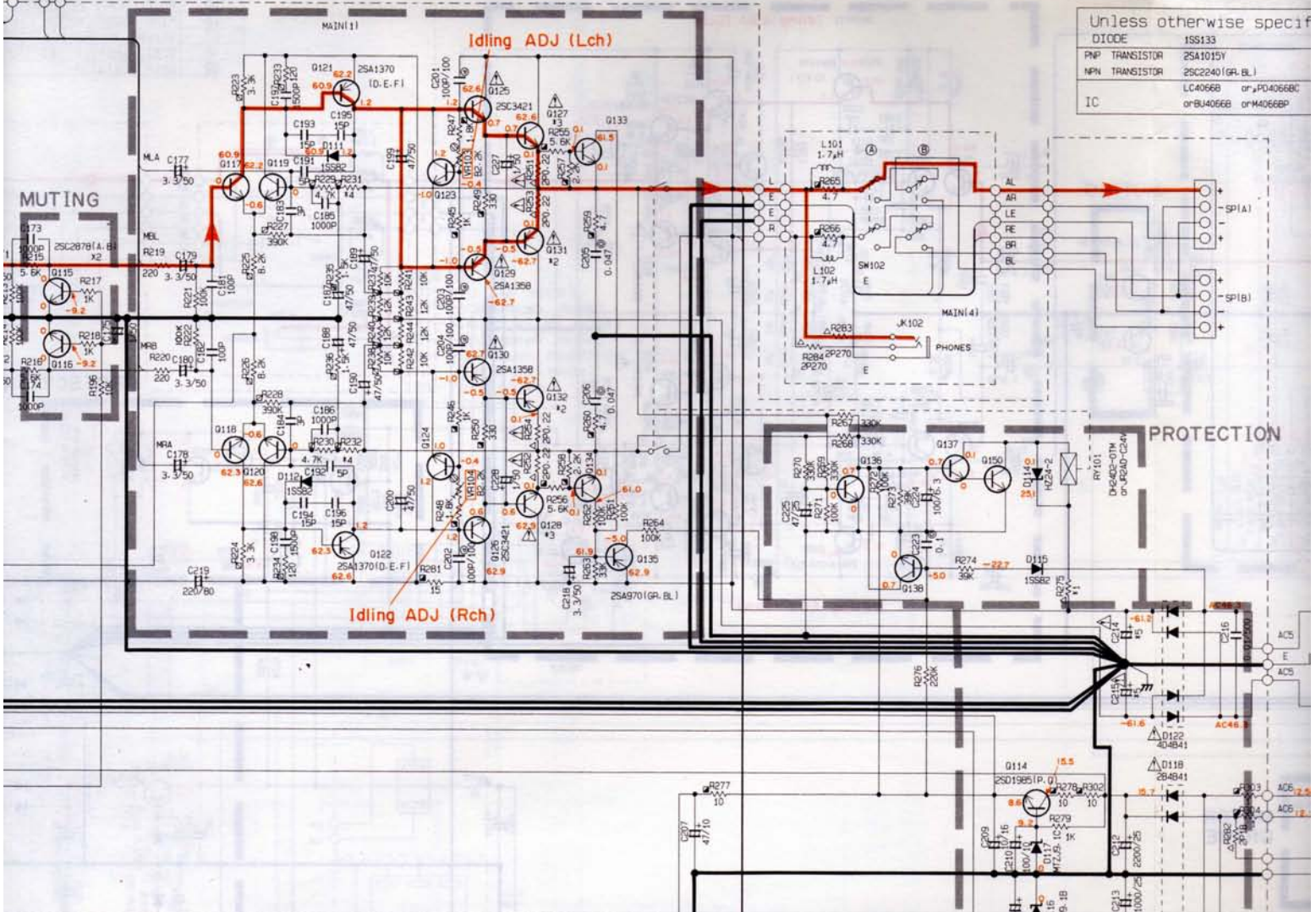

Unless otherwise specif

DIODE	1SS133
PNP TRANSISTOR	2SA1015V
NPN TRANSISTOR	2SC2240 (GR. BL.)
IC	LC4066B or PD4066B or BU4066B or M4066B

PROTECTION

MAIN

	LAST NO.	UN LISTED NO.
C	226	126, 165-170, 217-221
R	307	144, 166, 207, 287, 288, 300, 301
Q	151	
D	130	119-121, 123-129
IC		

SUB

	LAST NO.	UN LISTED NO.
C	409	401-403, 405-408
R	416	401-403, 405-407, 409-411
Q		
D	418	407, 409, 411, 413, 415, 417
IC		
F	403	402

		U.C	R.A.B	G
#1	R275	2P1.5K		2P1.2K
#2	Q131 Q132	2SA1301(R.O)		2SB1362(P.S.G)
#3	Q127 Q128	2SC3280(R.O)		2SD2053(P.S.G)
#4	R231 R232	27K		22K
#5	C214 C215	12000/71	B200/71	

RESISTOR

REMARKS	PARTS NAME
NO MARK	CARBON FILM RESISTOR (1/6W)
☒	CARBON FILM RESISTOR (1/4W)
△	METAL OXIDE FILM RESISTOR
▲	METEL FILM RESISTOR
⊠	METEL PLATE RESISTOR
⊞	FIRE PROOF CARBON FILM RESISTOR
⊞	SEMENT MOLDED RESISTOR
⊞	SEMI VARIABLE RESISTOR
■	CHIP RESISTOR

Unless otherwise specified

DIODE	1SS133
PNP TRANSISTOR	2SA1015Y
MPN TRANSISTOR	2SC2240(GR.BL)
IC	LC4066B or μPD4066BC or M4066B or BU4066B or M4066BP

CAPACITOR

REMARKS	PARTS NAME
NO MARK	ELECTROLYTIC CAPACITOR
⊗	TANTALUM CAPACITOR
NO MARK	CERAMIC CAPACITOR
⊙	POLYESTEL FILM CAPACITOR
○	POLYSTYRENE FILM CAPACITOR
⊖	MICA CAPACITOR
⊕	POLYPROPYLENE FILM CAPACITOR
●	SEMICONDUCTIVE CERAMIC CAPACITOR

NOTICE

- (U)..... U.S.A model
- (C)..... Canadian model
- (A)..... Australian model
- (G)..... European model
- (B)..... British model
- (R)..... General model
- (P)..... RP model

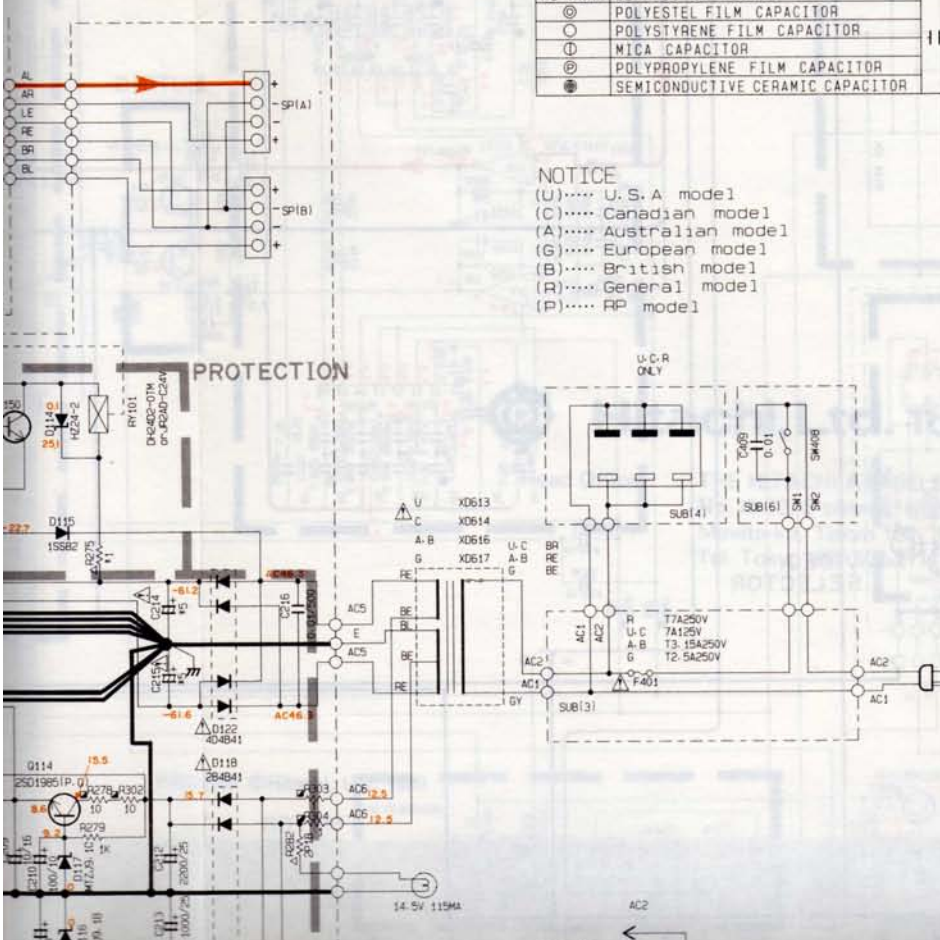

3

4





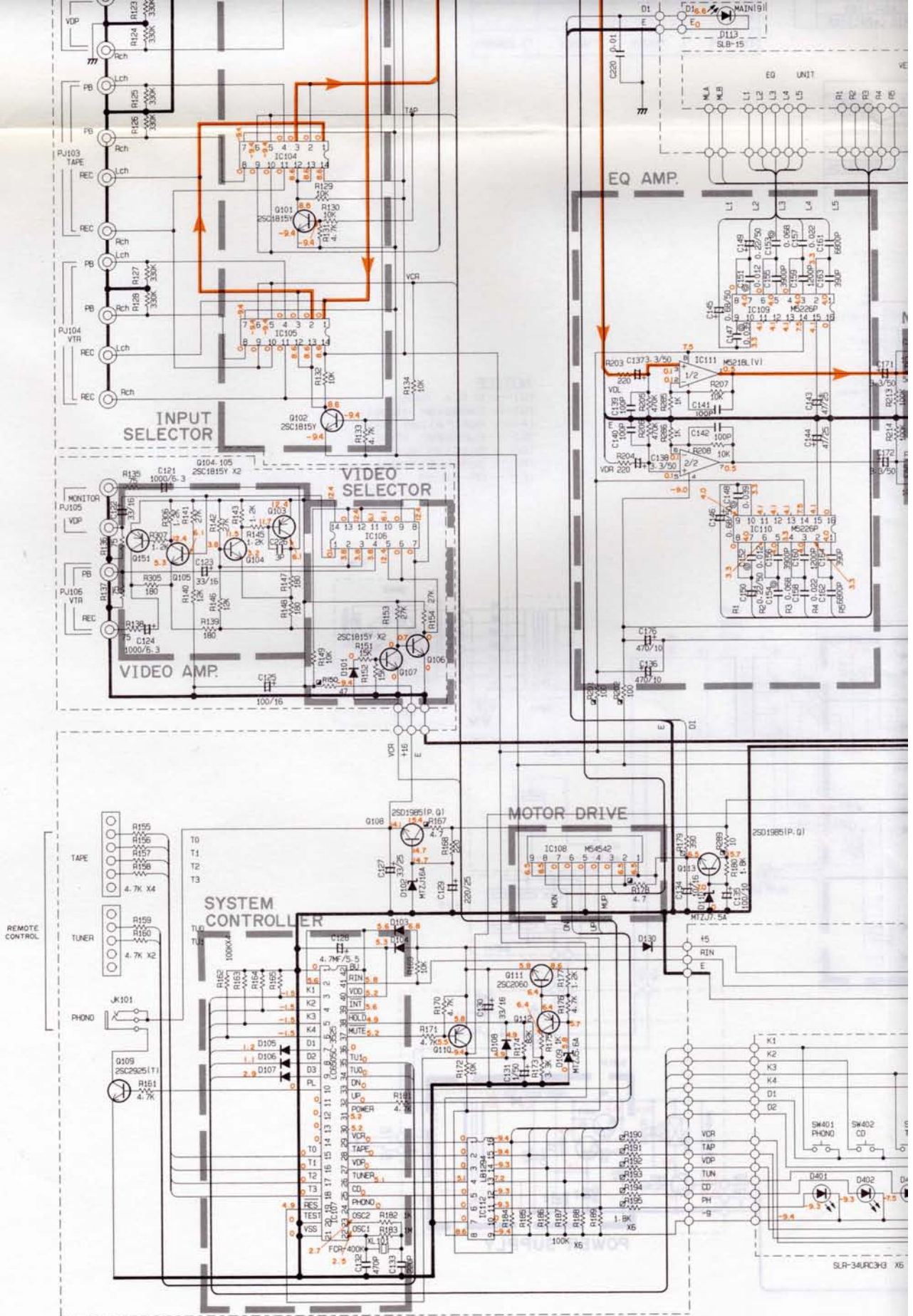

5

6

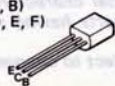
7

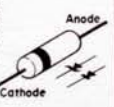
8

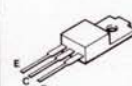

<p>2SA970 (GR, BL) 2SA1015 (Y) 2SA1815 (Y) 2SC2280 (R, O) 2SC2240 (GR, BL) 2SC2878 (A, B) 2SA1370 (D, E, F) 2SC2925ST 2SC2060</p> 	<p>2SA1301 (R, O) 2SB1362 (P, S, Q) 2SC3280 (R, O) 2SD2053 (P, S, Q) 2SA1358 2SC3421</p> 	<p>1SS82 1SS133 MTZJ5.6A MTZJ7.5A MTZJ9.1B MTZJ9.1C MTZJ16A HZ24-2</p> 	<p>4D4B41 2B4B41</p> 	<p>SLR-34URC3H3</p> 	<p>2SD1985</p> 	<p>M5218LV</p> 
---	--	--	---	---	--	--

*2	Q131 Q132	2SA1301(P, S, Q)		2SB1362(P, S, Q)
*3	Q127 Q128	2SC3280(P, S, Q)		2SD2053(P, S, Q)
*4	R231 R232	27K		22K
*5	C214 C215	12000/71	8200/71	

Unless otherwise specified

DIODE	1S5133
PNP TRANSISTOR	2SA1015Y
NPN TRANSISTOR	2SC2240(GR, BL)
IC	LC4066B or PD4066BC or M4066B or BU4066B or M4066BP

RESISTOR

REMARKS	PARTS NAME
NO MARK	CARBON FILM RESISTOR (1/6W)
□	CARBON FILM RESISTOR (1/4W)
△	METAL OXIDE FILM RESISTOR
▲	METAL FILM RESISTOR
⊠	METAL PLATE RESISTOR
■	FIRE PROOF CARBON FILM RESISTOR
□	CEMENT MOLDED RESISTOR
⊗	SEMI VARIABLE RESISTOR
■	CHIP RESISTOR

CAPACITOR

REMARKS	PARTS NAME
NO MARK	ELECTROLYTIC CAPACITOR
⊗	TANTALUM CAPACITOR
NO MARK	CERAMIC CAPACITOR
⊙	POLYESTER FILM CAPACITOR
○	POLYSTYRENE FILM CAPACITOR
⊖	MICA CAPACITOR
⊕	POLYPROPYLENE FILM CAPACITOR
⊗	SEMICONDUCTIVE CERAMIC CAPACITOR

NOTICE

(U)..... U.S.A model
 (C)..... Canadian model
 (A)..... Australian model
 (G)..... European model
 (B)..... British model
 (R)..... General model
 (P)..... RP model

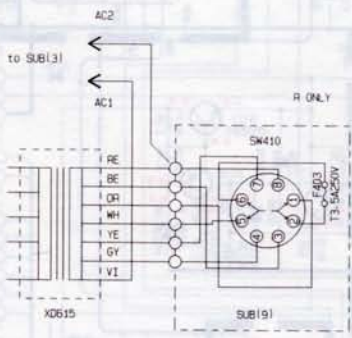
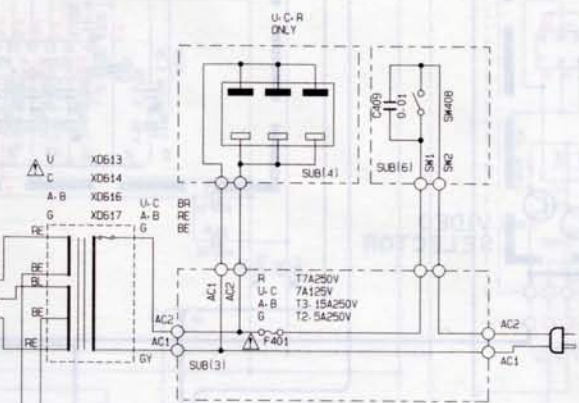
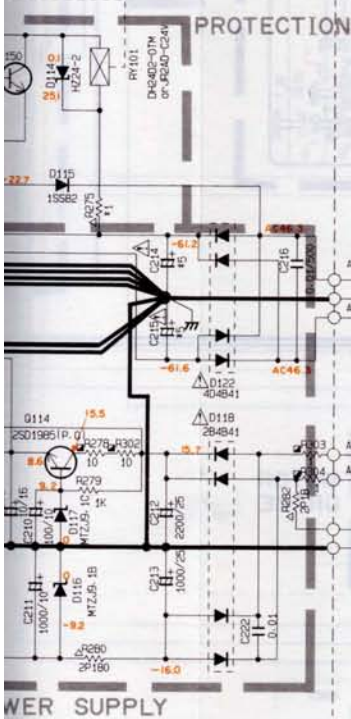
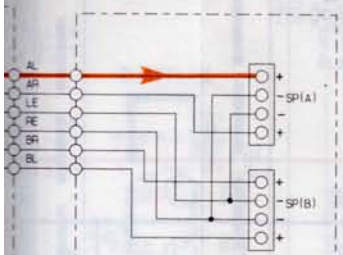

* All voltages are measured with a 10MΩ/DC electric volt meter.
 * Components having special characteristics are marked △ and must be replaced with parts having specifications equal to those originally installed.
 * Schematic diagram is subject to change without notice.

A-45 SCHEMATIC DIAGRAM

1
2
3
4
5
6

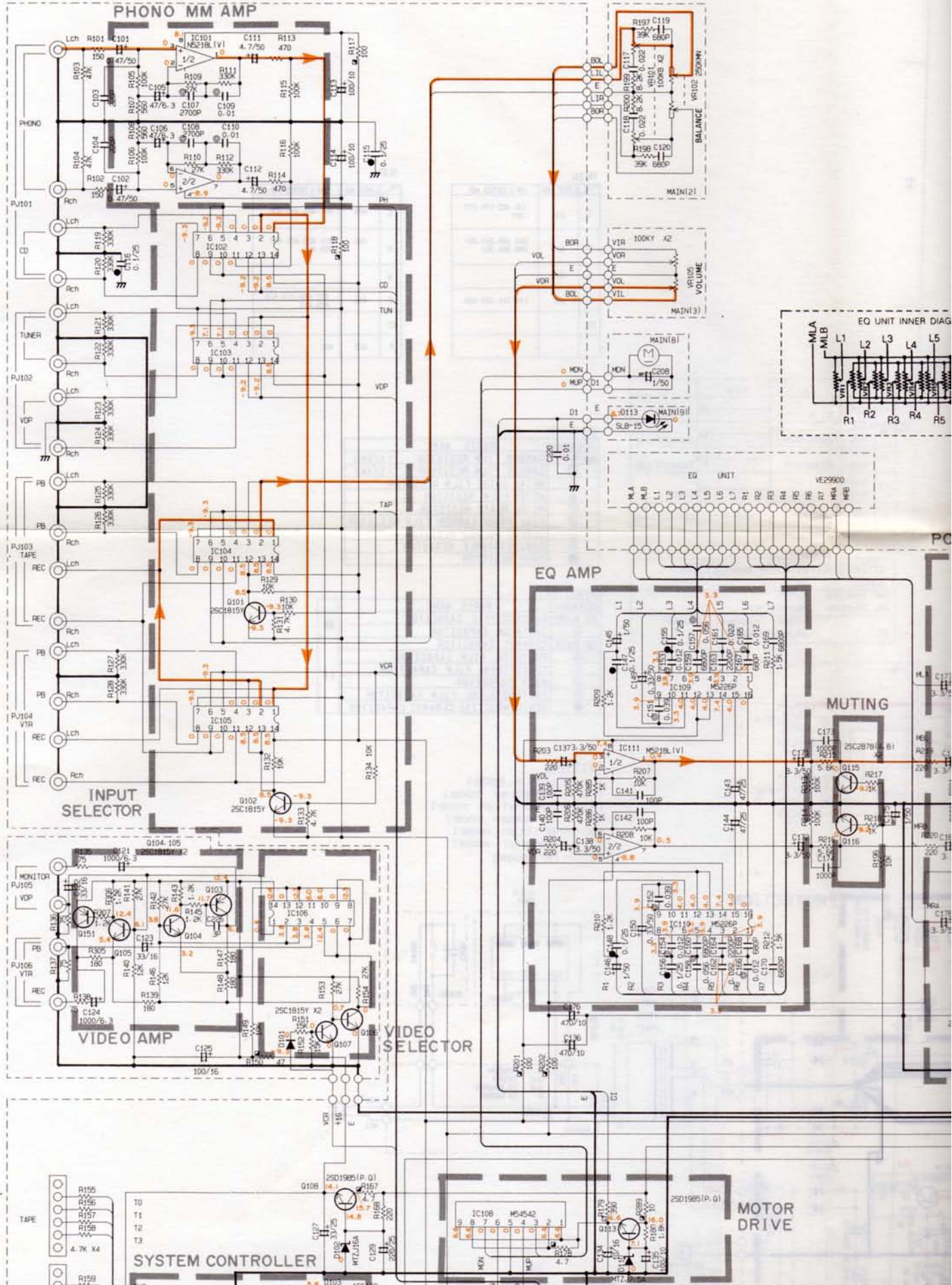

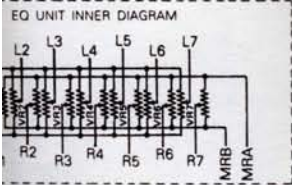

MAIN

	LAST NO.	UN LISTED NO.
C	208	216, 217, 221
R	307	144, 166, 267, 268 290-301
Q	151	127, 128, 131 132, 139-149
D	130	113, 123-129
IC		

SUB

	LAST NO.	UN LISTED NO.
C	408	401
R	418	417
Q		
D		
IC		
F	403	402

Unless otherwise specified

DIODE	1S5133
PNP TRANSISTOR	2SA1015Y
NPN TRANSISTOR	2SC2240(GR. BL.)
IC	LC4056B or PD4056BC or M4056BP or M4056B or BL4056B

CAPACITOR

REMARKS	PARTS NAME
NO MARK	ELECTROLYTIC CAPACITOR
NO MARK	CERAMIC CAPACITOR
⊙	POLYESTER FILM CAPACITOR
○	POLYSTYRENE FILM CAPACITOR
⊖	MICA CAPACITOR
⊕	POLYPROPYLENE FILM CAPACITOR
●	SEMICONDUCTIVE CERAMIC CAPACITOR

RESISTOR

REMARKS	PARTS NAME
NO MARK	CARBON FILM RESISTOR (1/6W)
⊠	CARBON FILM RESISTOR (1/4W)
△	METAL OXIDE FILM RESISTOR
⊞	METAL FILM RESISTOR
⊞	METAL PLATE RESISTOR
⊞	FIRE PROOF CARBON FILM RESISTOR
⊞	SEMI MOLDED RESISTOR
⊞	SEMI VARIABLE RESISTOR
■	CHIP RESISTOR

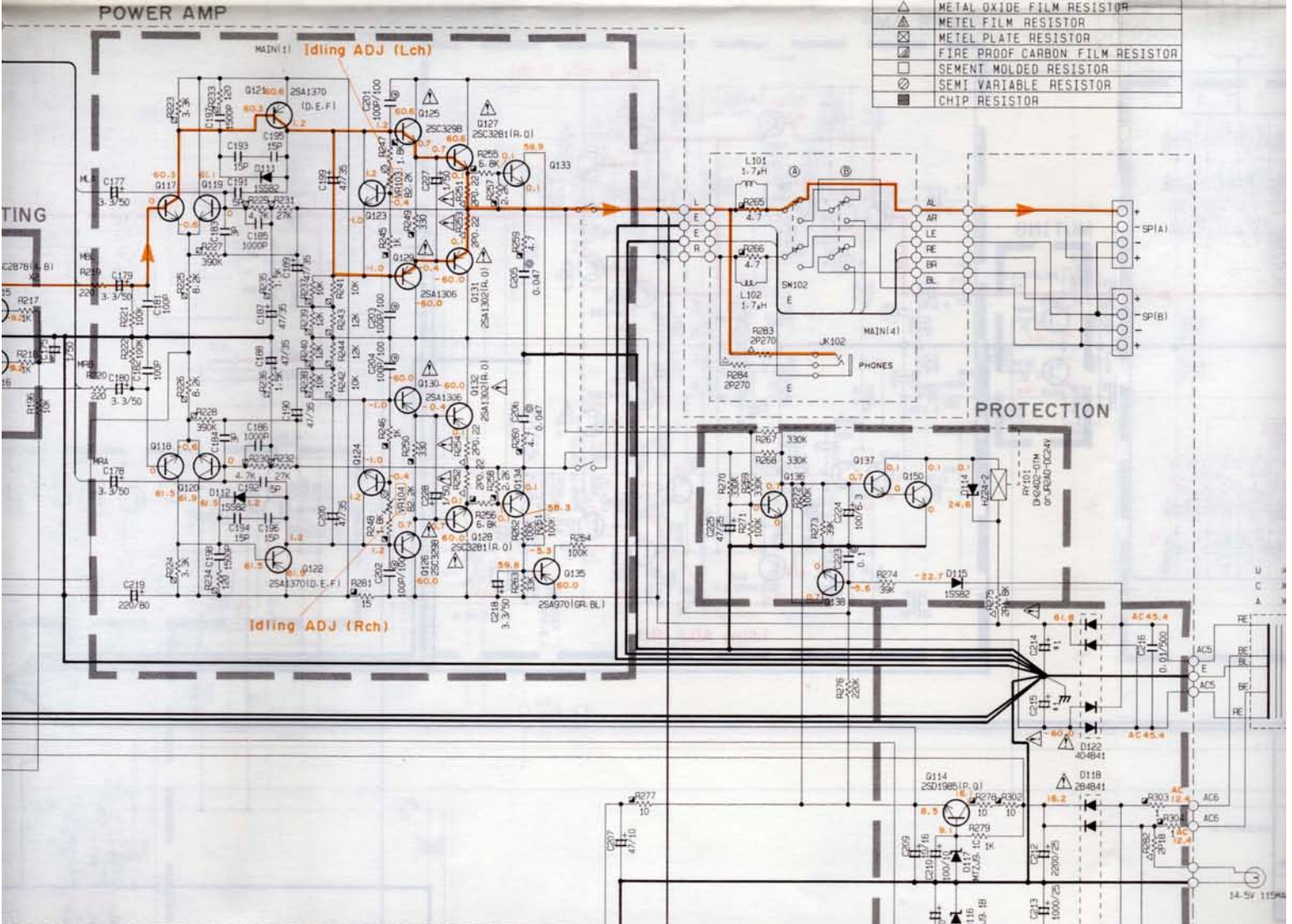

1- C
2-
3-
4-
5-
6-
7-
8-
9-
10-
11-
12-
13-

	U-C	R	A
1. C214, 215	V687570 or V687580	VE34000 or VE48560	▷
2. C405	OPEN	10/16	OPEN
3. R41B	OPEN	8.2K	OPEN
4. D420	OPEN	MTZ12C	OPEN
5. C406	OPEN	47/16	OPEN
6. Q403	OPEN	2SD1485	OPEN
7. Q402	OPEN	2SC2240 (GR, BL)	OPEN
8.	SHORT	OPEN	SHORT
9.			
10. C407	470/25	470/63	470/25
11. T401	XC0B3	XC0B2	XC0B4
12.			
13. F401	7A125V	77A250V	T3. 15A250V

d
4066BP
TDR
CITOR
APACITOR

(1/6W)
(1/4W)
RESISTOR

NOTICE

- (U)..... U.S.A model
- (C)..... Canadian model
- (A)..... Australian model
- (G)..... European model
- (B)..... British model
- (R)..... General model
- (P)..... AP model

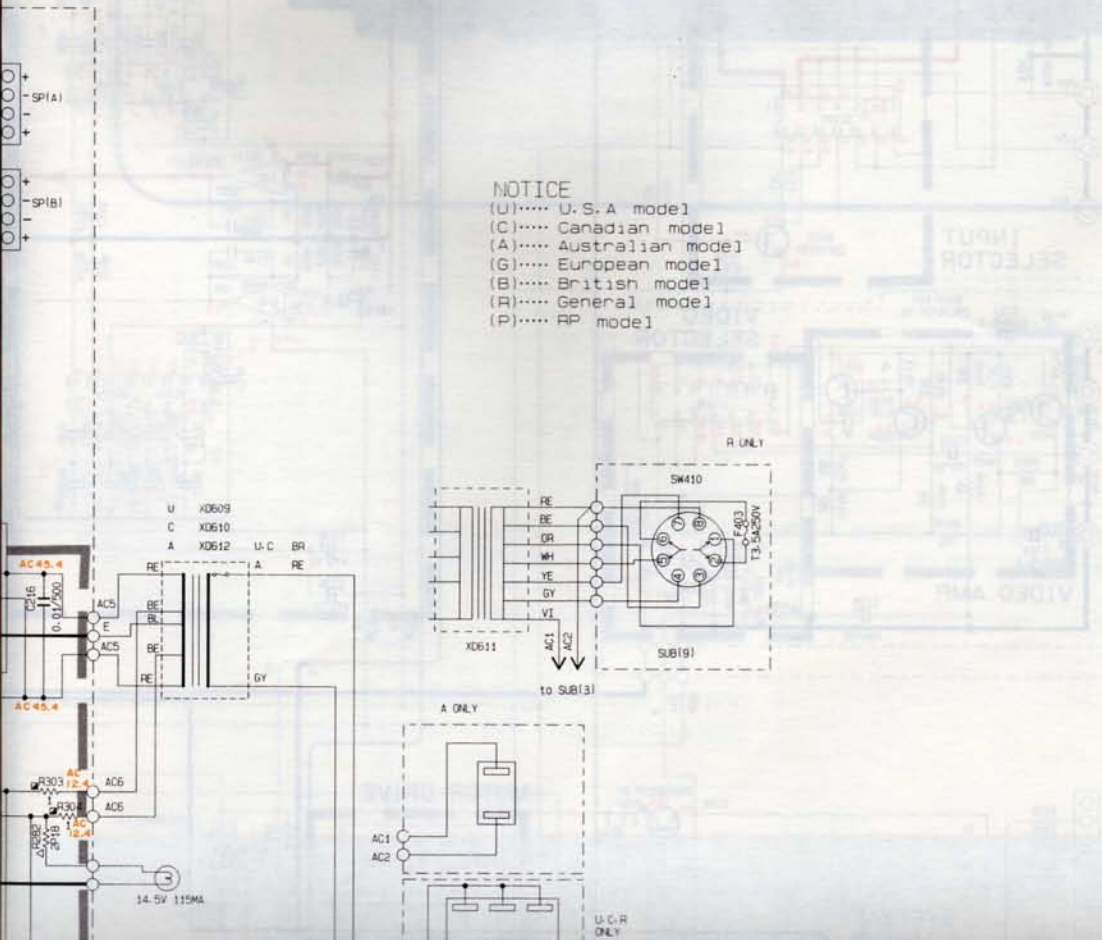

R ONLY

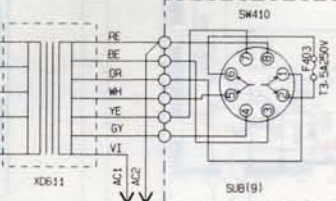

A ONLY

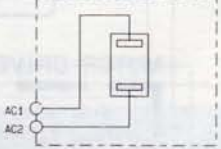

U-C-R ONLY

13- F401	7A125V	T7A250V	T3. 15A250V
----------	--------	---------	-------------

1/6W
1/4W
RESISTOR

NITAGHI

Instruction Manual

NOTICE
 (U)..... U.S.A model
 (C)..... Canadian model
 (A)..... Australian model
 (G)..... European model
 (B)..... British model
 (R)..... General model
 (P)..... RP model

VHS
Video Deck

VHS F540AW

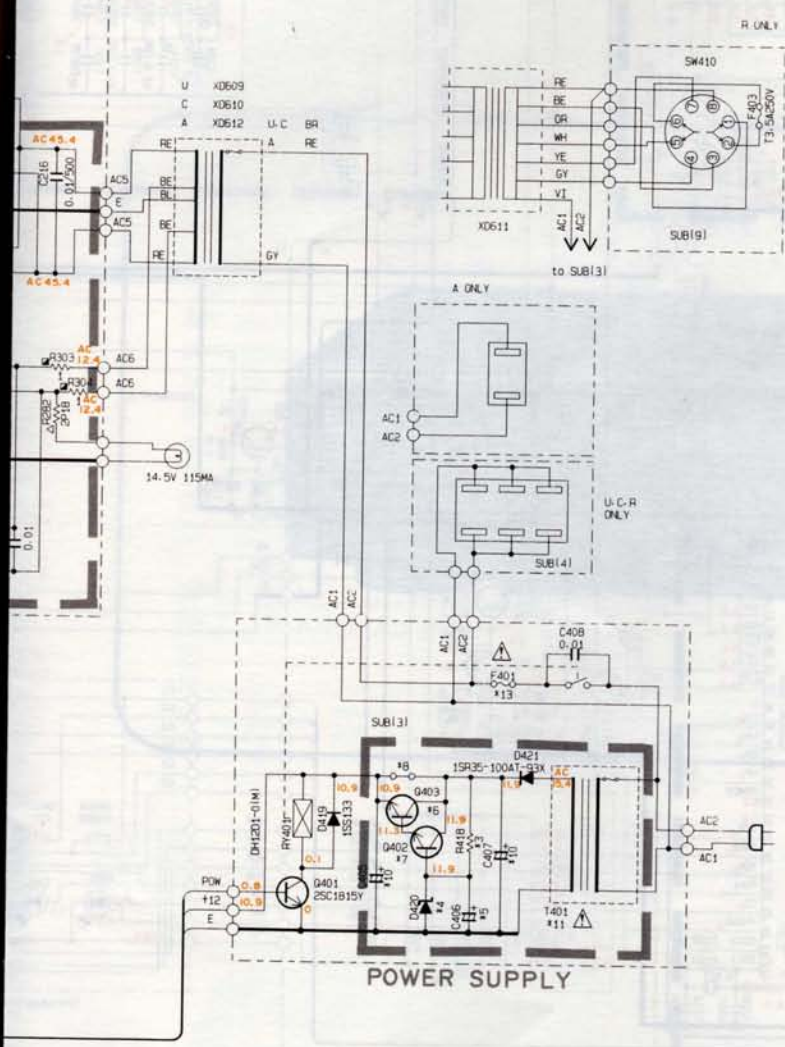

* All voltages are measured with a 10MΩ/DC electric volt meter.
 * Components having special characteristics are marked and must be replaced with parts having specifications equal to those originally installed.
 * Schematic diagram is subject to change without notice.

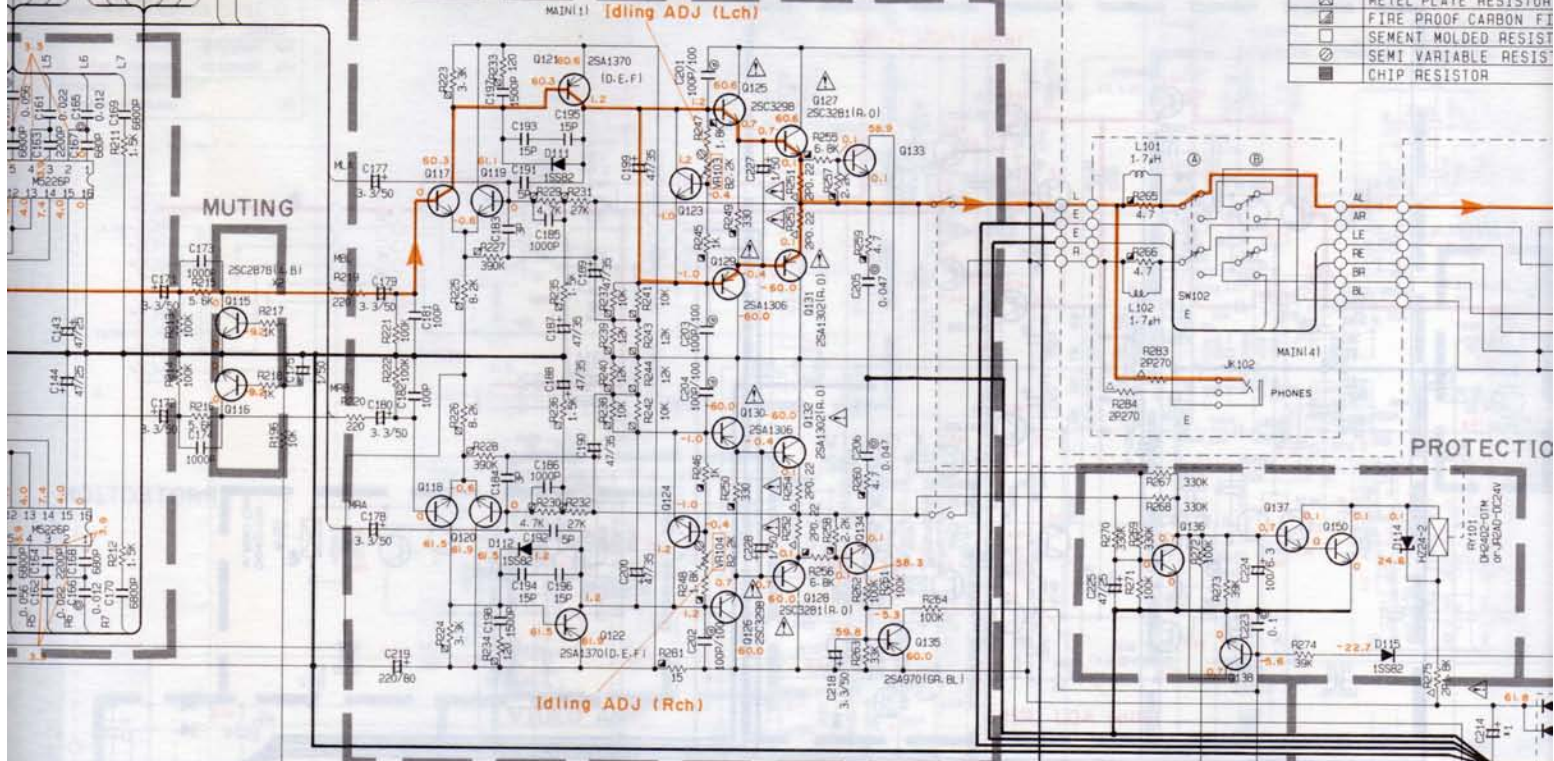

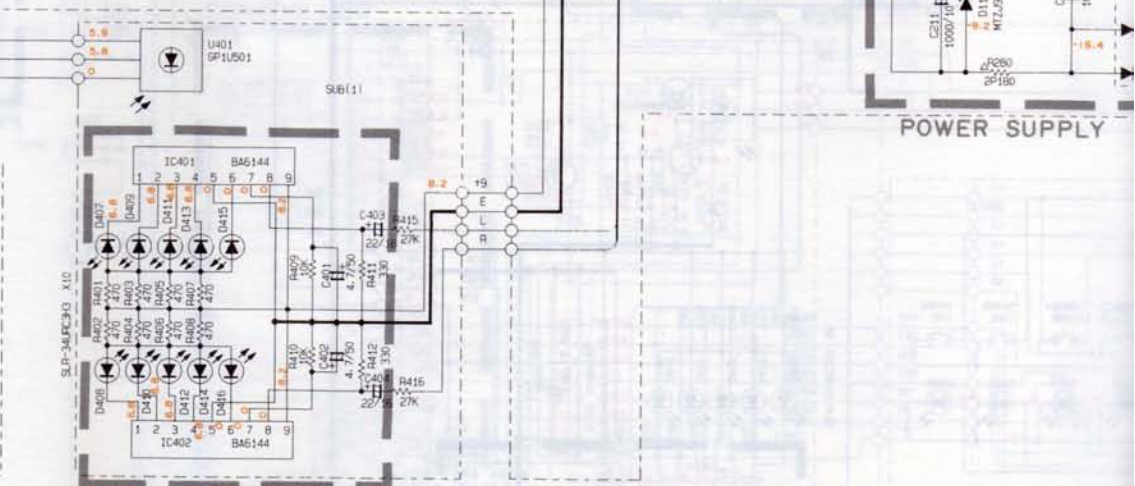
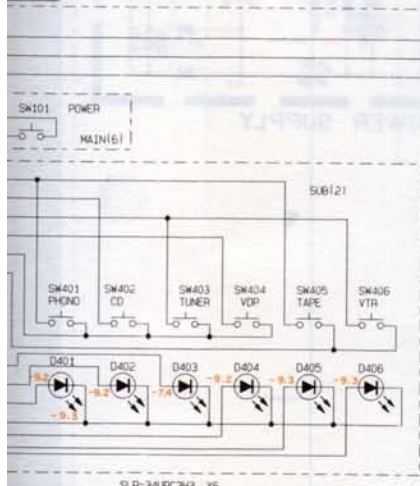
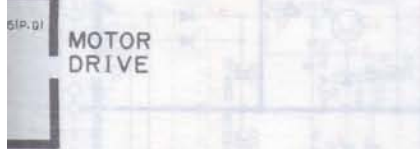

REMARKS	PARTS NAME
NO MARK	CARBON FILM RESISTOR
□	CARBON FILM RESISTOR
△	METAL OXIDE FILM RES
▲	METAL FILM RESISTOR
⊗	METAL PLATE RESISTOR
⊠	FIRE PROOF CARBON FI
⊞	CEMENT MOLDED RESIST
⊚	SEMI VARIABLE RESIST
■	CHIP RESISTOR

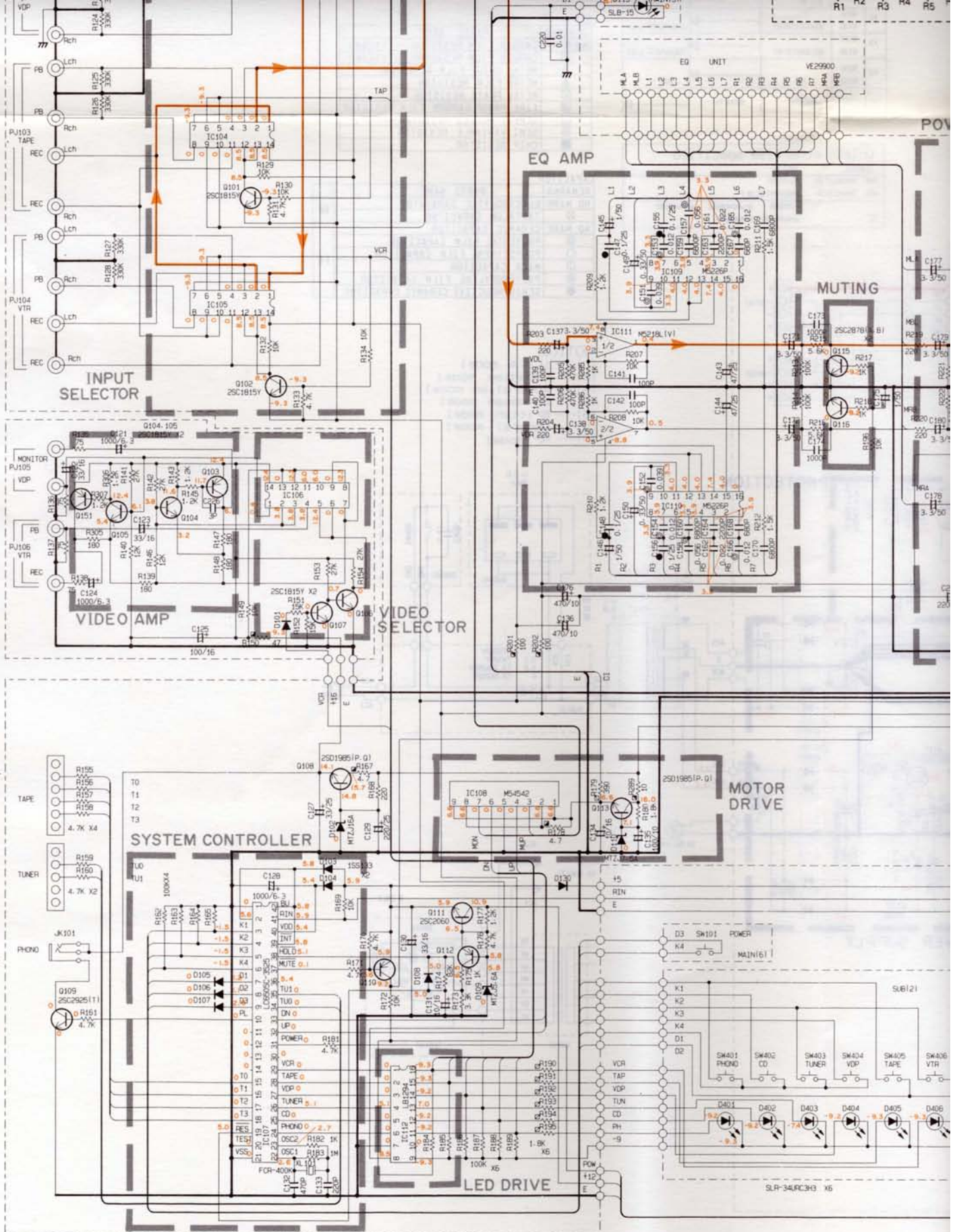

POWER SUPPLY

3-34URC3H3	2SD1485	M5218LV	M5226P	M54542	LC4066B	LB1294	BA6144	LC6505C-3525
Cathode	Anode							

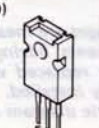
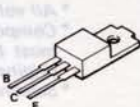
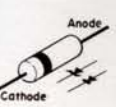
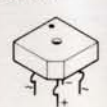
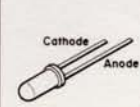
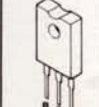
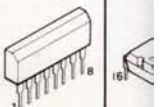

<p>2SA970 (GL, BL) 2SA1015 (Y) 2SC1815 (Y) 2SC2240 (GL, BL) 2SC2060 2SA1370 (D, E, F) 2SC2878 (A, B) 2SC2240 (GR, BL) 2S2925T</p> 	<p>2SA1302 (R, O) 2SC3281 (R, O) 2SA1306 2SC3298</p> 	<p>2SD1985</p> 	<p>1SS82 1SS133 MTZJ5.6A MTZJ7.5A MTZJ9.1B MTZJ9.1C MTZJ12C MTZJ16A HZ24-2 1SR35-100A</p> 	<p>4D4B1 2B4B1</p> 	<p>SLR-34URC3H3</p> 	<p>2SD1485</p> 	<p>M5218LV</p> 
---	--	--	--	--	---	--	--

A-40 PARTS LIST

■ A-40 ELECTRICAL PARTS

■ WARNING

Components having special characteristics are marked Δ and must be replaced with parts having specifications equal to those originally installed.

● Carbon resistors (1/6W or 1/4W) are not included in the ELECTRICAL PARTS list. For the parts No. of the carbon resistors, refer to P. 39.

A-40

A-40

Ref. No.	Part No.	Description			部 品 名	Remarks	Common Model	Markets	ランク
	VH 02 11 00	Main Circuit Board			メ イ ン シ ー ト			U	
	VH 02 12 00	"			"			C	
	VH 02 13 00	"			"			R, A, B	
	VH 02 14 00	"			"			G	
	FG 20 03 00	Ceramic Cap.	3pF	50V	セ ラ コ ン	C183, 184, 226			
	FG 21 05 00	"	5pF	50V	"	C191, 192			
	FG 21 11 50	"	15pF	50V	"	C193~196			
	FG 21 21 00	"	100pF	50V	"	C139~142, 181, 182			
	FG 21 22 20	"	220pF	50V	"	C103, 104, 133			
	FG 21 23 90	"	390pF	50V	"	C163, 164			
	FG 21 24 70	"	470pF	50V	"	C132			
	FG 21 26 80	"	680pF	50V	"	C119, 120			
	FG 21 31 00	"	1000pF	50V	"	C173, 174, 185, 186			
	FG 71 31 20	"	1200pF	50V	"	C159, 160			
	FG 21 31 50	"	1500pF	50V	"	C197, 198			
	FG 71 33 90	"	3900pF	50V	"	C155, 156			
	FG 24 36 80	"	6800pF	50V	"	C161, 162			
	FG 24 41 00	"	0.01 μ F	50V	"	C220, 222			
	FG 24 42 20	"	0.022 μ F	50V	"	C117, 118, 157, 158			
	FH 23 41 00	"	0.01 μ F	500V	"	C216			
	FZ 00 41 30	Semiconductive Ceramic Cap.	0.1 μ F	25V	半 導 体 セ ラ コ ン	C115, 116			Δ
	FA 15 32 70	Mylar Cap.	2700pF	50V	マ イ ラ ー コ ン	C107, 108			
	FA 15 41 00	"	0.01 μ F	50V	"	C109, 110			
	FA 15 41 20	"	0.012 μ F	50V	"	C151, 152			
	FA 15 43 90	"	0.039 μ F	50V	"	C147, 148			
	FA 15 44 70	"	0.047 μ F	50V	"	C205, 206			
	FA 15 46 80	"	0.068 μ F	50V	"	C153, 154			
	FA 15 51 00	"	0.1 μ F	50V	"	C223			
	UJ 11 74 70	Electrolytic Cap.	47 μ F	6.3V	ケ ミ コ ン	C105, 106			
	UJ 11 81 00	"	100 μ F	6.3V	"	C224			
	UJ 12 74 70	"	47 μ F	10V	"	C207			
	UJ 12 81 00	"	100 μ F	10V	"	C113, 114, 135, 210			
	UJ 12 84 70	"	470 μ F	10V	"	C136, 176			
	UJ 13 71 00	"	10 μ F	16V	"	C134, 209			
	UJ 13 73 30	"	33 μ F	16V	"	C122, 123, 130			
	UJ 13 81 00	"	100 μ F	16V	"	C125			
	UJ 14 73 30	"	33 μ F	25V	"	C127			
	UJ 14 74 70	"	47 μ F	25V	"	C143, 144, 225			
	UJ 14 82 20	"	220 μ F	25V	"	C129			
	VG 29 12 00	"	47 μ F	50V	"	C187~190, 199, 200			
	UJ 16 52 20	"	0.22 μ F	50V	"	C149, 150			
	UJ 16 54 70	"	0.47 μ F	50V	"	C101, 102			
	Ui 36 56 80	"	0.68 μ F	50V	"	C145, 146			
	UJ 16 61 00	"	1 μ F	50V	"	C131, 227, 228			
	UJ 46 63 30	"	3.3 μ F	50V	"	C137, 138, 171, 172, 177~180, 218			
	UJ 16 64 70	"	4.7 μ F	50V	"	C111, 112			
	UH 12 91 00	"	1000 μ F	10V	"	C211			
	UH 14 91 00	"	1000 μ F	25V	"	C213			
	UJ 14 92 20	"	2200 μ F	25V	"	C212			
	FM 11 61 00	"	1 μ F	50V	B P ケ ミ コ ン	C175, 208			
	FZ 00 72 00	"	220 μ F	80V	オーディオケミコン	C219			
	VB 17 01 00	"	4700 μ F	5.5V	バックアップケミコン	C128			
	VE 33 99 00	"	8200 μ F	71V	ブ ロ ッ ク ケ ミ コ ン	C214, 215		R, A, B, G	

※New Parts (新規部品) NR

※Carbon resistors (1/10W or 1/4W) are not included in the ELECTRICAL PARTS list. For the parts No. of the carbon resistor, refer to P. 38.

※Carbon resistors (1/10W or 1/4W) are not included in the ELECTRICAL PARTS list. For the parts No. of the carbon resistor, refer to P. 38.

※Comments listing special characteristics are marked Δ and must be replaced with parts having specifications equal to those originally installed.

※Comments listing special characteristics are marked Δ and must be replaced with parts having specifications equal to those originally installed.

A-40 PARTS LIST

A-40 ELECTRICAL PARTS

Ref. No.	Part No.	Description	部 品 名	Remarks	Common Model	Markets	ランク
※	VG 87 57 00	Electrolytic Cap.	12000 μ F 71V	ブ ロ ッ ク ケ ミ コ ン	C214,215	U,C	
	UJ 11 91 00	//	1000 μ F 6.3V	ケ ミ コ ン	C121,124		
	UT 45 21 00	Polypropylene Film Cap.	100pF 100V	ポ リ プ ロ コ ン	C201~204		
	HJ 35 51 20	Carbon Resistor	120 Ω 1/4W	カ ー ボ ン 抵 抗	R233,234		
	HJ 35 53 90	//	390 Ω 1/4W	//	R179		
	HJ 35 61 50	//	1.5k Ω 1/4W	//	R235,236		
	HJ 35 61 80	//	1.8k Ω 1/4W	//	R190~195		
	HJ 35 63 30	//	3.3k Ω 1/4W	//	R223,224		
	HJ 35 64 70	//	4.7k Ω 1/4W	//	R229,230		
	HJ 35 68 20	//	8.2k Ω 1/4W	//	R225,226		
	HJ 35 71 00	//	10k Ω 1/4W	//	R237,238,241,242		
	HJ 35 71 20	//	12k Ω 1/4W	//	R239,240,243,244		
	HJ 35 72 20	//	22k Ω 1/4W	//	R231,232	G	
	HJ 35 72 70	//	27k Ω 1/4W	//	//	U,C,R,A,B	
	HJ 35 83 90	//	390k Ω 1/4W	//	R227,228		
	HL 32 22 20	Metal Oxide Film Resistor	0.22 Ω 2W	酸 金 抵 抗	R251~254		
	HL 32 41 80	//	18 Ω 2W	//	R282		
	HL 32 51 80	//	180 Ω 2W	//	R280		
	HL 32 52 70	//	270 Ω 2W	//	R283,284		
	HL 32 61 20	//	1.2k Ω 2W	//	R275	G	
	HL 32 61 50	//	1.5k Ω 2W	//	//	U,C,R,A,B	
	HV 45 31 00	Flame Proof Carbon Resistor	1 Ω 1/4W	不 燃 化 カ ー ボ ン 抵 抗	R303,304		
	HV 45 34 70	//	4.7 Ω 1/4W	//	R167,178,259,260,265,266		
	HV 45 41 00	//	10 Ω 1/4W	//	R277,278,289,302		
	HV 45 41 50	//	15 Ω 1/4W	//	R281		
	HV 45 44 70	//	47 Ω 1/4W	//	R150		
	HV 45 51 00	//	100 Ω 1/4W	//	R117,118,201,202		
	HV 45 53 30	//	330 Ω 1/4W	//	R249,250		
	HV 45 61 00	//	1k Ω 1/4W	//	R245,246		
	HV 45 61 80	//	1.8k Ω 1/4W	//	R247,248		
	HV 45 62 20	//	2.2k Ω 1/4W	//	R257,258		
	HV 45 65 60	//	5.6k Ω 1/4W	//	R255,256		
	VB 86 12 00	Pre-Set Potentiometer	B2.2k Ω	半 固 定 抵 抗	VR103,104		
	VE 29 93 00	Potentiometer	250kMN	可 変 抵 抗 器	VR102		
	VE 29 94 00	//	100k \times 2	//	VR101		
	VE 29 95 00	Potentiometer with Motor	100k \times 2	モ ー タ ー 付 ポ リ ュ ーム	VR105		
	iA 09 70 00	Transistor	2SA970(GR,BL)	ト ラ ン ジ ス タ ー	Q135		
	iA 10 15 11	//	2SA1015(Y)	//	Q103,110,112,151		
	iC 18 15 20	//	2SC1815(Y)	//	Q101,102,104~107		
	iC 22 40 00	//	2SC2240(GR,BL)	//	Q117~120,123,124,133,134,136~138,150		
	iX 60 42 00	//	2SC2878(A,B)	//	Q115,116		
	iC 20 60 00	//	2SC2060	//	Q111		
	VA 85 47 00	//	2SA1370(D,E,F)	//	Q121,122		
	VE 91 96 00	//	2SC2925(T)	//	Q109		
	VE 02 92 00	//	2SD1985	//	Q108,113,114		
	iX 60 35 80	//	2SA1358	//	Q129,130		
	iX 60 35 90	//	2SC3421	//	Q125,126		
	iF 00 14 00	Diode	ISS82	ダ イ オ ー ド	D111,112,115		
	iF 00 34 50	//	ISS133	//	D101,103~108,130		

※New Parts (新規部品) NR

Ref. No.	Part No.	Description	部 品 名		Remarks	Common Model	Markets	ランク
iH	00 11 60	Diode Bridge	4D4B4I	ダイオードブリッジ	DI22			
iH	00 09 90	//	2B4B4I	//	DI18			
VG	43 76 00	Zener Diode	MTZJ5.6A	ツェナーダイオード	DI09			
VG	43 85 00	//	MTZJ7.5A	//	DI10			
VG	43 92 00	//	MTZJ9.1B	//	DI16			
VG	43 93 00	//	MTZJ9.1C	//	DI17			
VG	44 10 00	//	MTZJ16A	//	DI02			
iF	00 72 40	//	HZ24-2	//	DI14			
iG	05 82 10	IC	M5218LV	I C	IC101,111			
iG	15 14 00	//	M5226P	//	IC109,110			
iG	05 49 00	//	M54542	//	IC108			
iG	08 92 00	//	LC4066B	//	IC102~106			
XA	54 90 01	//	LB1294	//	IC112			
XD	62 70 01	//	LC6505C-3525	//	IC107			
VF	40 00 00	Push Switch	2-2	プッシュスイッチ	SW102			
GD	90 04 70	Coil	1.7 μ H	コイル	LI01,102			
GG	00 07 00	Ceramic Resonator	FCR-400K	セラミック振動子	XL101			
KC	00 19 40	Relay	DH2TU24VDC	リレー	RY101			
VC	36 44 00	Pin Jack	2P	ピンジャック	PJ105,106			
LB	40 10 30	//	4P	//	PJ102~104			
LB	40 10 50	//	4P	//	PJ101			
LB	30 17 60	Headphone Jack		ヘッドホンジャック	JK102			
LB	10 07 30	Mini Jack		ミニジャック	JK101			
LB	50 07 10	ST Connector	5P	S T コネクター	CB101			
LB	60 83 90	//	6P	//	CB102			
VD	00 45 00	Base Pin	2P	i-Type P H ベースピン i 型	CB106			
VD	00 46 00	//	3P	i-Type //	CB107			
VD	00 47 00	//	4P	i-Type //	CB109			
VD	00 48 00	//	5P	i-Type //	CB110			
VD	00 49 00	//	6P	i-Type //	CB111			
VD	00 50 00	//	7P	i-Type //	CB112,116,117			
LA	00 20 00	Lapping Terminal	P=7.5 2P	i 型ラッピング端子板				
LA	00 21 10	//	P=5 2P	//				
LA	00 21 20	//	P=5 3P	//				
VB	84 59 00	Speaker Terminal	8P	スピーカ端子				
VA	82 15 00	Radiator		ラジエター			C	
BB	06 95 10	Ground Metal		ランド金具				
BA	08 40 00	Heat Sink		放熱器				
Ei	33 00 86	Binding Head Tapping Screw	3 \times 8 FCRM3-BI	バインドタッピングネジ	PACK			
EZ	00 13 50	Cup Tyte Screw	3 \times 14 FCRM3-BI	カップタイトネジ			C	

*New Parts (新規部品) NR

A-40 EXPLODED VIEW

1
2
3
4
5
6
7

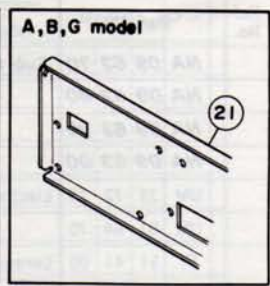
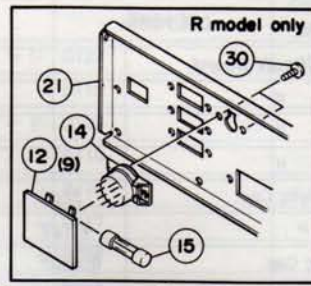
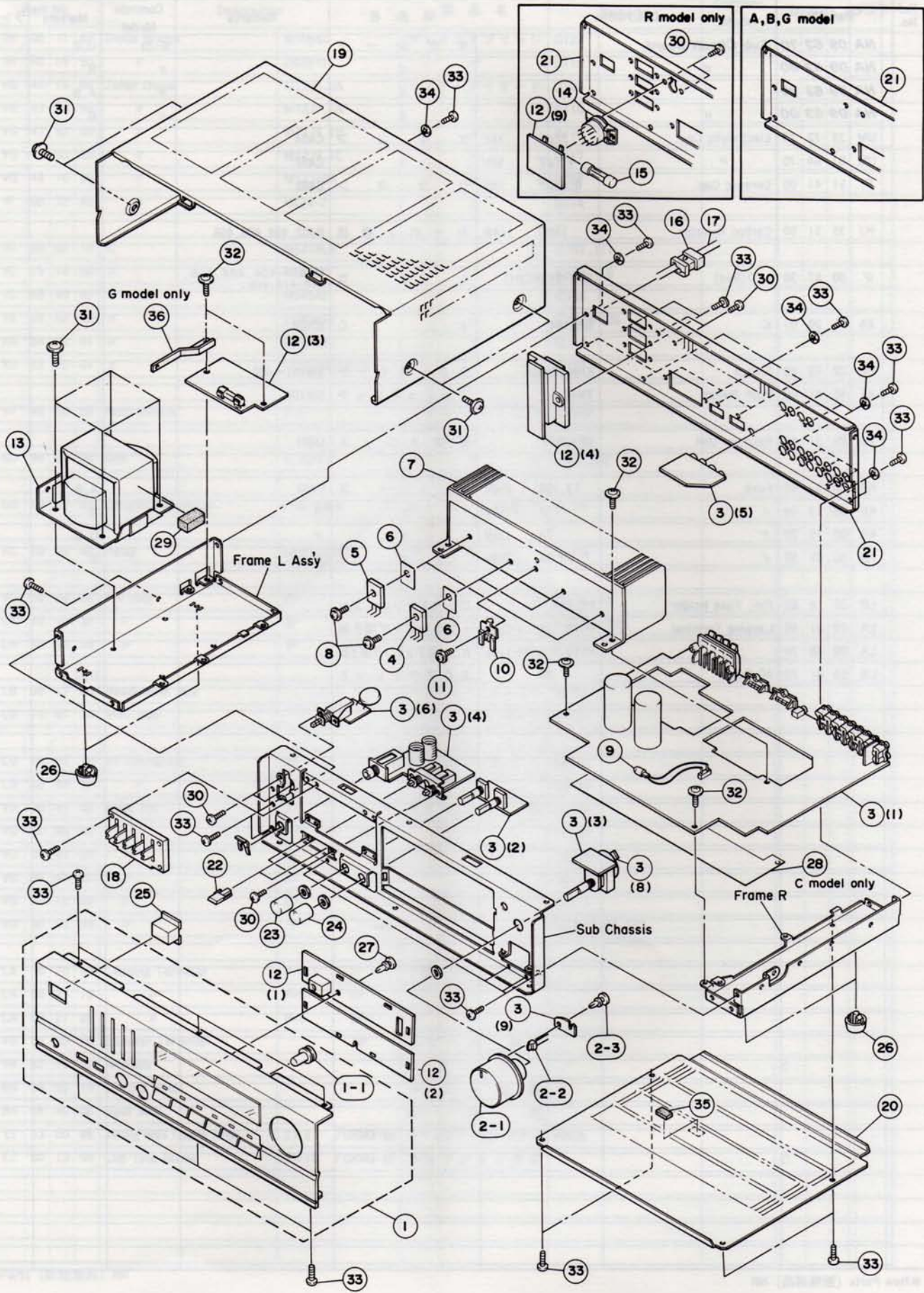

A-40 MECHANISM PARTS

Note) φ : Diameter

Ref. No.	Part No.	Description	部 品 名	Remarks	Common Model	Markets	ランク
※	I	VH 02 05 00	Panel Unit	パネルユニット			
	1-1	VE 41 10 00	Lamp Cap.	ランプキャップ			
	2-1	VD 35 49 00	Knob Ass'y	ツマミ Ass'y			
	2-2	VD 27 06 00	LED (Red)	LED			
	2-3	VB 66 92 00	Plastic Rivet	プラスチックリベット			
※	3	VH 02 11 00	Main Circuit Board	メインシート		U	
※	//	VH 02 12 00	//	//		C	
※	//	VH 02 13 00	//	//		R,A,B	
※	//	VH 02 14 00	//	//		G	
※	4	iX 60 81 10	Transistor	トランジスター	Q131, 132	U,C,R,A,B	
	//	iX 61 10 40	//	//	//	G	
※	5	iX 60 81 20	//	//	Q127, 128	U,C,R,A,B	
	//	iX 61 10 50	//	//	//	G	
	6	VC 39 72 00	Sheet	デンカシートジャンボ		U,C,R,A,B	
	//	VB 43 50 00	//	放熱シート		G	
	7	VE 24 66 00	Radiator	ラジエター			
	8	EZ 00 13 50	Cup Tight Screw	カップタイトスクリュー			
	9	VE 62 89 00	Lamp	ランプ			
	10	AA 62 87 90	Support, TR	サポートTR			
	11	EZ 00 16 10	Cup Tight Screw	カップタイトスクリュー			
	12	NA 09 62 70	Sub Circuit Board	サブシート		A-29	U,C
	//	NA 09 62 80	//	//		//	R
	//	NA 09 62 90	//	//		//	A,B
	//	NA 09 63 00	//	//		//	G
※	13	XD 61 3D 00	Power Transformer	電源トランス		U	△
	//	XD 61 40 03	//	//		C	△
	//	XD 61 50 03	//	//		R	△
	//	XD 61 60 03	//	//		A,B	△
	//	XD 61 70 03	//	//		G	△
	14	VA 93 29 00	Voltage Selector	電圧切換器		R	△
	15	KB 00 03 70	Fuse	ヒューズ		R	△
	16	VD 77 82 00	Cord Stopper	コードストッパー		U,C	
	//	VD 37 59 00	//	//		R,A,B,G	
	17	MG 00 22 20	Power Cord	電源コード		U,C	△
	//	MG 00 16 30	//	//		R	△
	//	MG 00 23 10	//	//		A	△
	//	MG 00 23 30	//	//		B	△
	//	MG 00 23 20	//	//		G	△
	18	VE 29 89 00	Slide Volume	スライドVR			
	19	VE 24 67 00	Top Cover	トップカバー			
	20	AA 62 88 20	Bottom Cover	ボトムカバー			
※	21	VG 95 97 00	Rear Panel	リアパネル		R	
※	//	VG 95 96 00	//	//		U,C	
※	//	VG 95 98 00	//	//		A,B	
※	//	VG 95 99 00	//	//		G	
	22	CB 63 42 30	Push Button	プッシュボタン			
	23	CB 62 60 40	Knob	ツマミ	BALANCE		
	24	VE 37 37 00	//	//	LOUDNESS		
	25	CB 66 08 10	Button	ボタン	POWER		
	26	CB 61 03 90	Leg	トランレグ			
	27	CB 60 56 20	Plastic Rivet	プラスチックリベット			
	28	VF 29 86 00	Shield Plate	シールドプレート		C	
	29	CB 65 34 00	Cushion	クッション			

※New Parts (新規部品) NR

A-45 ELECTRICAL PARTS
A-45 PARTS LIST

WARNING
Components having special characteristics are marked with parts having special specifications and must be replaced with parts having specifications equal to those originally installed.
*Carbon resistors (1/4W or 1/2W) are not included in the ELECTRICAL PARTS list. For the parts list of the carbon resistor, refer to P. 32.

Ref. No.	Part No.	Description	部 品 名	Remarks	Common Model	Markets	ランク
29	CB 65 34 00	Cushion	ク ッ シ ョ ン				
30	ED 33 00 66	Binding Head Screw	3×6 FCRM3-BI バ イ ン ド 小 ネ ジ	PACK			
31	EK 36 50 40	BW Head Screw	4×8 FCRM3-BI B W ヘ ッ ド 小 ネ ジ				
32	EX 60 02 40	BW Head Tapping Screw	3×8(φ10)FCRM3-BI B W ヘ ッ ド タ ッ ピ ン グ ネ ジ	PACK			
33	Ei 33 00 86	Binding Head Tapping Screw	3×8 FCRM3-BI バ イ ン ド タ ッ ピ ン グ ネ ジ	PACK			
34	EV 41 30 36	Toothed Lock Washer	φ3 FCRM3-BI 歯 付 座 金	PACK			
35	VF 20 15 00	Damper	ダ ン パ ー				
36	VF 45 33 00	Stopper	ス ト ッ パ ー			G	
	CB 06 92 51	Binding Tie	BK-1 イ ン シ ュ ロ ッ ク タイ	PACK			
		Accessories	付 属 品				
	VH 04 16 00	Remote Control Transmitter	RS-CS40 リ モ ー ト コ ン ト ロ ー ル ト ラ ン ス ミ ッ タ ー				
		Dry Cell	AA,R6 単 3 乾 電 池				

*New Parts (新規部品) NR

A-45 PARTS LIST

A-45 ELECTRICAL PARTS

■ WARNING

Components having special characteristics are marked Δ and must be replaced with parts having specifications equal to those originally installed.

● Carbon resistors (1/6W or 1/4W) are not included in the ELECTRICAL PARTS list. For the parts No. of the carbon resistors, refer to P. 39.

Ref. No.	Part No.	Description			部 品 名	Remarks	Common Model	Markets	ランク
※	VH 02 33 00	Main Circuit Board			メ イ ン シ ー ト			U,C	
※	VH 02 34 00	"						R,A	
	FG 20 03 00	Ceramic Cap.	3pF	50V	セ ラ コ ン	C183, 184, 226			
	FG 21 05 00	"	5pF	50V	"	C191, 192			
	FG 21 11 50	"	15pF	50V	"	C193~196			
	FG 21 21 00	"	100pF	50V	"	C139~142, 181, 182			
	FG 21 22 20	"	220pF	50V	"	C103, 104, 133			
	FG 21 24 70	"	470pF	50V	"	C132			
	FG 21 26 80	"	680pF	50V	"	C119, 120, 167, 168			
	FG 21 31 00	"	1000pF	50V	"	C173, 174, 185, 186			
	FG 21 31 50	"	1500pF	50V	"	C197, 198			
	FG 41 32 20	"	2200pF	50V	"	C163, 164			
	FG 24 36 80	"	6800pF	50V	"	C159, 160, 169, 170			
	FG 24 41 00	"	0.01 μ F	50V	"	C220, 222			
	FG 24 42 20	"	0.022 μ F	50V	"	C117, 118, 161, 162			
	FH 23 41 00	"	0.01 μ F	500V	"	C216			
	FZ 00 41 30	Semiconductive Ceramic Cap.	0.1 μ F	25V	半 導 体 セ ラ コ ン	C115, 116, 147, 148, 155, 156			Δ
	FA 15 32 70	Mylar Cap.	2700pF	50V	マ イ ラ ー コ ン	C107, 108			
	FA 15 41 00	"	0.01 μ F	50V	"	C109, 110			
	FA 15 41 20	"	0.012 μ F	50V	"	C153, 154, 165, 166			
	FA 15 43 90	"	0.039 μ F	50V	"	C151, 152			
	FA 15 44 70	"	0.047 μ F	50V	"	C205, 206			
	FA 15 45 60	"	0.056 μ F	50V	"	C157, 158			
	FA 15 51 00	"	0.1 μ F	50V	"	C223			
	UJ 11 74 70	Electrolytic Cap.	47 μ F	6.3V	ケ ミ コ ン	C105, 106			
	UH 01 81 00	"	100 μ F	6.3V	"	C224			
	UJ 12 74 70	"	47 μ F	10V	"	C207			
	UJ 12 81 00	"	100 μ F	10V	"	C113, 114, 135, 210			
	UJ 12 84 70	"	470 μ F	10V	"	C136, 176			
	UJ 13 71 00	"	10 μ F	16V	"	C131, 134, 209			
	UJ 13 73 30	"	33 μ F	16V	"	C122, 123, 130			
	UJ 13 81 00	"	100 μ F	16V	"	C125			
	UJ 14 73 30	"	33 μ F	25V	"	C127			
	UJ 14 74 70	"	47 μ F	25V	"	C143, 144, 225			
	UJ 14 82 20	"	220 μ F	25V	"	C129			
	VE 01 92 00	"	47 μ F	35V	"	C187~190, 199, 200			
	UJ 16 53 30	"	0.33 μ F	50V	"	C149, 150			
	UJ 16 54 70	"	0.47 μ F	50V	"	C101, 102			
	UJ 16 61 00	"	1 μ F	50V	"	C145, 146, 227, 228			
	UJ 46 63 30	"	3.3 μ F	50V	"	C137, 138, 171, 172, 177~180, 218			
	UJ 16 64 70	"	4.7 μ F	50V	"	C111, 112			
	UJ 11 91 00	"	1000 μ F	6.3V	"	C121, 124, 128			
	UH 14 91 00	"	1000 μ F	25V	"	C213			
	UH 12 91 00	"	1000 μ F	10V	"	C211			
	UJ 14 92 20	"	2200 μ F	25V	"	C212			
	FM 11 61 00	"	1 μ F	50V	B P コ ン	C175, 208			
	FZ 00 72 00	"	220 μ F	80V	オーディオケミコン	C219			
	VE 34 00 00	"	10000 μ F	69V	ブ ロ ッ ク ケ ミ コ ン	C214, 215		R,A	
	VG 87 57 00	"	12000 μ F	71V	"	"		U,C	
	UT 45 21 00	Polypropylene Film Cap.	100pF	100V	ポ リ プ ロ コ ン	C201~204			
	HJ 35 51 20	Carbon Resistor	120 Ω	1/4W	カ ー ボ ン 抵 抗	R233, 234			
	HJ 35 53 90	"	390 Ω	1/4W	"	R179			

※New Parts (新規部品) NR

70 (品名検索) 2007.08.08

Ref. No.	Part No.	Description	部 品 名	Remarks	Common Model	Markets	ランク
	HJ 35 61 50	Carbon Resistor	1.5k Ω 1/4W	カーボン抵抗	R235,236		
	HJ 35 61 80	//	1.8k Ω 1/4W	//	R190~195		
	HJ 35 63 30	//	3.3k Ω 1/4W	//	R223,224		
	HJ 35 64 70	//	4.7k Ω 1/4W	//	R229,230		
	HJ 35 68 20	//	8.2k Ω 1/4W	//	R225,226		
	HJ 35 71 00	//	10k Ω 1/4W	//	R237,238,241,242		
	HJ 35 71 20	//	12k Ω 1/4W	//	R239,240,243,244		
	HJ 35 72 70	//	27k Ω 1/4W	//	R231,232		
	HJ 35 83 90	//	390k Ω 1/4W	//	R227,228		
	HL 32 22 20	Metal Oxide Film Resistor	0.22 Ω 2W	酸金抵抗	R251~254		
	HL 32 41 80	//	18 Ω 2W	//	R282		
	HL 32 51 80	//	180 Ω 2W	//	R280		
	HL 32 52 70	//	270 Ω 2W	//	R283,284		
	HL 32 61 80	//	1.8k Ω 2W	//	R275		
	HV 45 31 00	Flame Proof Carbon Resistor	1 Ω 1/4W	不燃化カーボン抵抗	R303,304		
	HV 45 34 70	//	4.7 Ω 1/4W	//	R167,178,259,260,265,266		
	HV 45 41 00	//	10 Ω 1/4W	//	R277,278,289,302		
	HV 45 41 50	//	15 Ω 1/4W	//	R281		
	HV 45 44 70	//	47 Ω 1/4W	//	R150		
	HV 45 51 00	//	100 Ω 1/4W	//	R117,118,201,202		
	HV 45 53 30	//	330 Ω 1/4W	//	R249,250		
	HV 45 61 00	//	1k Ω 1/4W	//	R245,246		
	HV 45 61 80	//	1.8k Ω 1/4W	//	R247,248		
	HV 45 62 20	//	2.2k Ω 1/4W	//	R257,258		
	HV 45 66 80	//	6.8k Ω 1/4W	//	R255,256		
	VB 86 12 00	Pre-Set Potentiometer	B2.2k Ω	半固定抵抗	VR103,104		
	VE 29 93 00	Potentiometer	250kMN	可変抵抗器	VR102		
	VE 29 94 00	//	100k \times 2	//	VR101		
	VE 29 95 00	Potentiometer with Motor	100k \times 2	モーター付ボリューム	VR105		
	iA 09 70 00	Transistor	2SA970(GR,BL)	トランジスター	Q135		
	iA 10 15 11	//	2SA1015(Y)	//	Q103,110,112,151		
	iC 18 15 20	//	2SC1815(Y)	//	Q101,102,104~107		
	iC 22 40 00	//	2SC2240(GR,BL)	//	Q117~120,123,124, 133,134,136~138,150		
	iX 60 42 00	//	2SC2878(A,B)	//	Q115,116		
	iC 20 60 00	//	2SC2060	//	Q111		
	iX 60 81 50	//	2SA1306	//	Q129,130		
	iX 60 81 60	//	2SC3298	//	Q125,126		
	VA 85 47 00	//	2SA1370(D,E,F)	//	Q121,122		
	VE 91 96 00	//	2SC2925(T)	//	Q109		
	VE 02 92 00	//	2SD1985	//	Q108,113,114		
	iF 00 14 00	Diode	ISS82	ダイオード	D111,112,115		
	iF 00 34 50	//	ISS133	//	D101,103~108,130		
	iH 00 11 60	Diode Bridge	4D4B41	ダイオードブリッジ	D122		
	iH 00 09 90	//	2B4B41	//	D118		
	VG 43 76 00	Zener Diode	MTZJ5.6A	ツェナーダイオード	D109		
	VG 43 85 00	//	MTZJ7.5A	//	D110		
	VG 43 92 00	//	MTZJ9.1B	//	D117		
	VG 43 93 00	//	MTZJ9.1C	//	D116		
	VG 44 10 00	//	MTZJ16A	//	D102		
	iF 00 72 40	//	HZ24-2	//	D114		

*New Parts (新規部品) NR

Ref. No.	Part No.				Description	部 品 名		Remarks	Common Model	Markets	ランク
iG	05	82	10	IC	M5218LV	I	C	IC101,111			
iG	15	14	00	//	M5226P		//	IC109,110			
iG	05	49	00	//	M54542		//	IC108			
iG	08	92	00	//	LC4066B		//	IC102~106			
XA	54	90	01	//	LB1294		//	IC112			
XD	62	70	01	//	LC6505C-3525		//	IC107			
VE	32	73	00	Switch	KHH-MA901	タ	ク	ト	ス	イ	ツ
VF	40	00	00	Push Switch	2-2	ブ	ッ	シ	ユ	ス	イ
GD	90	04	70	Coil	1.7 μ H	コ	イ	ル	L101,102		
GG	00	07	00	Ceramic Resonator	FCR-400K	セ	ラ	ミ	ツ	ク	振
KC	00	19	40	Relay	DH2TU24VDC	リ	レ	ー	RY101		
VC	36	44	00	Pin Jack	2P	ピ	ン	ジ	ャ	ッ	ク
LB	40	10	30	//	4P		//	PJ102~104			
LB	40	10	50	//	4P		//	PJ101			
LB	30	17	60	Headphone Jack		ヘ	ッ	ド	ホ	ー	ン
LB	10	07	30	Mini Jack		ミ	ニ	ジ	ャ	ッ	ク
LB	50	07	10	ST Connector	5P	S	T	コ	ネ	ク	タ
LB	60	83	90	//	6P		//	CB102			
VD	00	45	00	Base Pin	2P	i-Type	P	H	ベ	ー	ス
VD	00	46	00	//	3P	i-Type		//	CB107,114,115		
VD	00	47	00	//	4P	i-Type		//	CB109		
VD	00	48	00	//	5P	i-Type		//	CB110		
VD	00	49	00	//	6P	i-Type		//	CB111		
VD	00	50	00	//	7P	i-Type		//	CB112		
VD	00	52	00	//	9P	i-Type		//	CB116,117		
LA	00	20	00	Lapping Terminal	P=7.5 2P	i-Type	i	型	ラ	ッ	ピ
LA	00	21	10	//	P=5 2P	i-Type		//			
LA	00	21	20	//	P=5 3P	i-Type		//			
VB	84	59	00	Speaker Terminal	8P	ス	ピ	ー	カ	ー	端
VA	82	15	00	Radiator		ラ	ジ	エ	タ	ー	
BB	06	95	10	Ground Metal		ラ	ン	ド	金	具	
BA	08	40	00	Heat Sink		放	熱	器			
Ei	33	00	86	Binding Head Tapping Screw	3 \times 8	FCRM3-BI	バ	イ	ン	ド	タ
EK	93	00	10	BW Head Tapping Screw	3 \times 8	ZMC2-BI	B	W	ヘ	ッ	ド

※New Parts (新規部品) NR

Ref. No.	Part No.	Description	部 品 名	Remarks	Common Model	Markets	ランク
	NA 09 63 20	Sub Circuit Board	サ ブ シ ー ト		A-3I	U,C	
	NA 09 63 30	"	"		//	R	
	NA 09 63 40	"	"		//	A	
	Fi 51 41 00	Ceramic Cap.	0.01 μ F 50V	セ ラ コ ン	C408		
	UJ 13 71 00	Electrolytic Cap.	10 μ F 16V	ケ ミ コ ン	C405	R	
	UJ 13 74 70	"	47 μ F 16V	"	C406	R	
	UM 39 72 20	"	22 μ F 16V	"	C403,404		
	UM 07 64 70	"	4.7 μ F 50V	"	C401,402		
	UJ 14 84 70	"	470 μ F 25V	"	C407	U,C,A	
	UW 67 84 70	"	470 μ F 63V	"	"	R	
	HJ 35 51 80	Carbon Resistor	180 Ω 1/4W	カ ー ボ ン 抵 抗	R401~408		
	HJ 35 68 20	"	8.2k Ω 1/4W	"	R418	R	
	iC 18 15 20	Transistor	2SC1815(Y)	ト ラ ン ジ ス タ ー	Q401		
	iC 22 40 00	"	2SC2240(GR,BL)	"	Q402	R	
	VB 22 27 00	"	2SD1485	"	Q403	R	
	XA 55 20 01	IC	BA6144	I C	IC401,402		
	iF 00 34 50	Diode	ISS133	ダ イ オ ー ド	D419		
	iH 00 14 30	"	ISR35-100A	"	D421		
	iF 00 88 70	Zener Diode	MTZ12C	ツ ェ ナ ー ダ イ オ ー ド	D420	R	
	iF 00 87 30	LED(Red)	SLR-34URC3H3	L E D	D401~416		
	VE 32 73 00	Switch	KHH-MA90I	タ ク ト ス イ ッ チ	SW401~406		
	VD 85 31 00	Receiver Unit	GPIU501	受 光 ユ ニ ッ ト	U401		
	VE 56 89 00	Relay	DH12DI-0(M)	リ レ ー	RY401		
	KB 00 07 60	Fuse	T3.15A 250V	ヒ ュ ー ズ	F401	A	△
	KB 00 13 00	"	T7.0A 250V	"	"	R	△
	KB 00 15 20	"	7A 125V	"	"	U,C	△
	XC 08 20 01	Power Transformer		電 源 ト ラ ン ス	T401	R	△
	XC 08 30 01	"		"	"	U,C	△
	XC 08 40 01	"		"	"	A	△
	LB 20 18 80	Pin, Fuse Holder	PC-FHI	ヒ ュ ー ズ ホ ル ダ ー ピ ン			
	LA 00 21 40	Lapping Terminal	P=10 2P i-Type	i 型 ラ ッ ピ ン ン ぐ 端 子 板			
	LA 00 38 70	"	P=10 2P WTM-Type	W T M 型 ラ ッ ピ ン ン ぐ 端 子 板			
	LB 60 81 70	AC Outlet	3P	A C ア ウ ト レ ッ ト		U,C,R	△

*New Parts (新規部品) NR

A-45 EXPLODED VIEW

1
2
3
4
5
6
7

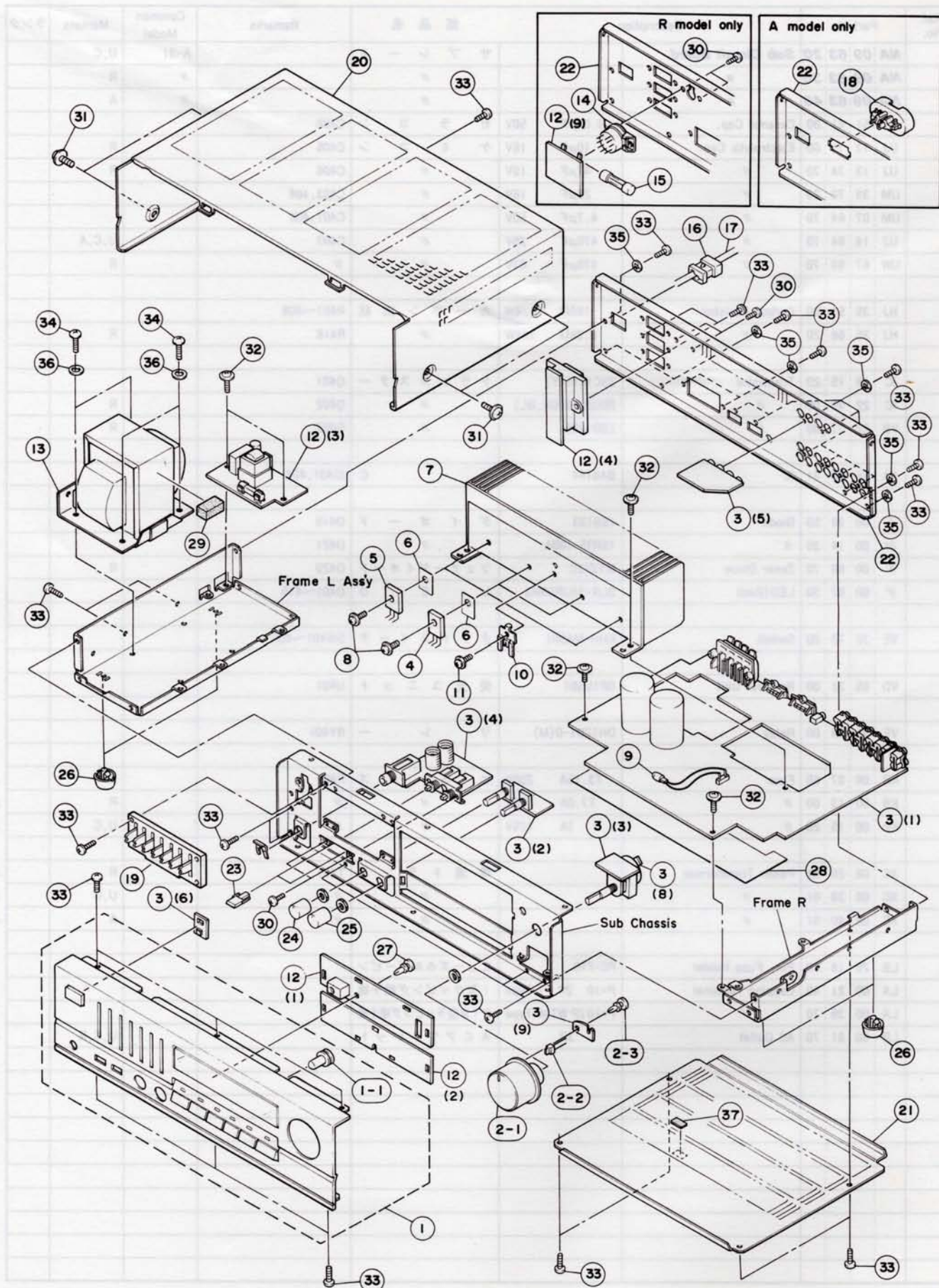

A-45 MECHANISM PARTS

Note) ϕ : Diameter

Ref. No.	Part No.	Description	部 品 名	Remarks	Common Model	Markets	ランク
1	VH 02 28 00	Panel Unit	パネルユニット				
1-1	VE 41 10 00	Lamp Cap.	ランプキャップ				
2-1	VD 35 49 00	Knob Ass'y	ノブ Ass'y				
2-2	VD 27 06 00	LED (Red)	LED				
2-3	VB 66 92 00	Plastic Rivet	プラスチックリベット				
3	VH 02 33 00	Main Circuit Board	メインシート			U,C	
//	VH 02 34 00	//	//			R,A	
4	iX 61 43 60	Transistor	トランジスター	Q131,132			
5	iX 61 43 70	//	//	Q127,128			
6	VC 39 72 00	Sheet	デンカシートジャンボ				
7	VE 24 65 00	Radiator	ラジエター				
8	EZ 00 13 50	Cup Tight Screw	カップタイトスクリュー				
9	VE 62 89 00	Lamp	ランプ				
10	AA 62 87 90	Support, TR	サポートTR				
11	EZ 00 16 10	Cup Tight Screw	カップタイトスクリュー				
12	NA 09 63 20	Sub Circuit Board	サブシート		A-31	U,C	
//	NA 09 63 30	//	//		//	R	
//	NA 09 63 40	//	//		//	A	
13	XD 61 10 02	Power Transformer	電源トランス			R	△
//	XD 60 90 03	//	//			U	△
//	XD 61 00 02	//	//			C	△
//	XD 61 20 02	//	//			A	△
14	VA 93 29 00	Voltage Selector	電圧切換器			R	△
15	KB 00 03 70	Fuse	ヒューズ			R	△
16	VD 77 82 00	Cord Stopper	コードストッパー			U,C	
//	VD 37 59 00	//	//			R,A	
17	MG 00 22 20	Power Cord	電源コード			U,C	△
//	MG 00 16 30	//	//			R	△
//	MG 00 23 10	//	//			A	△
18	VC 62 61 00	AC Outlet	ACアウトレット			A	△
19	VE 29 90 00	Slide Volume	スライドVR				
20	VE 24 67 00	Top Cover	トップカバー		AV-33		
21	AA 62 88 20	Bottom Cover	ボトムカバー				
22	VG 96 01 00	Rear Panel	リアパネル			R	
//	VG 96 00 00	//	//			U,C	
//	VG 96 02 00	//	//			A	
23	CB 63 42 30	Push Button	プッシュボタン				
24	CB 62 60 40	Knob	ツマミ	BALANCE			
25	VE 37 37 00	//	ノブ	LOUDNESS			
26	CB 61 03 90	Leg	トランレグ				
27	CB 60 56 20	Plastic Rivet	プラスチックリベット				
28	VF 29 86 00	Shield Plate	シールドプレート			C	
29	CB 65 34 00	Cushion	クッション				
30	ED 33 00 66	Binding Head Screw	バインド小ネジ	PACK			
31	EK 36 50 40	BW Head Screw	BWヘッド小ネジ				
32	EX 60 02 40	BW Head Tapping Screw	BWヘッドタッピングネジ				
33	Ei 33 00 86	Binding Head Tapping Screw	バインドタッピングネジ	PACK			
34	ED 34 01 06	Binding Head Screw	バインド小ネジ	PACK			
35	EV 41 30 36	Toothed Lock Washer	歯付座金	PACK			
36	EV 20 30 46	Plain Washer	平座金	PACK			
37	VF 20 15 00	Damper	ダンパー			U,R,A	
	CB 06 92 51	Binding Tie	インシュロックタイ	PACK			

※New Parts (新規部品) NR

機種 (品番) 4720/1 5001/1

RS-CS50/40 REMOTE CONTROL TRANSMITTER

EXPLODED VIEW

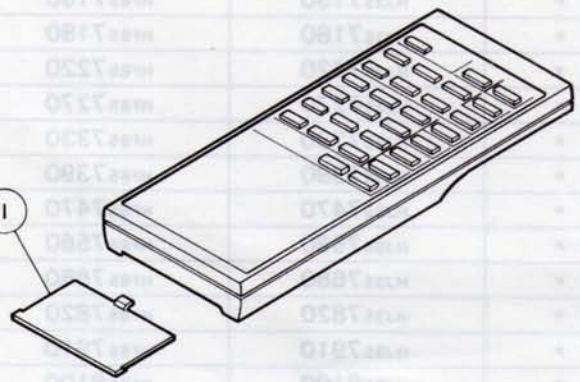

SCHEMATIC DIAGRAM

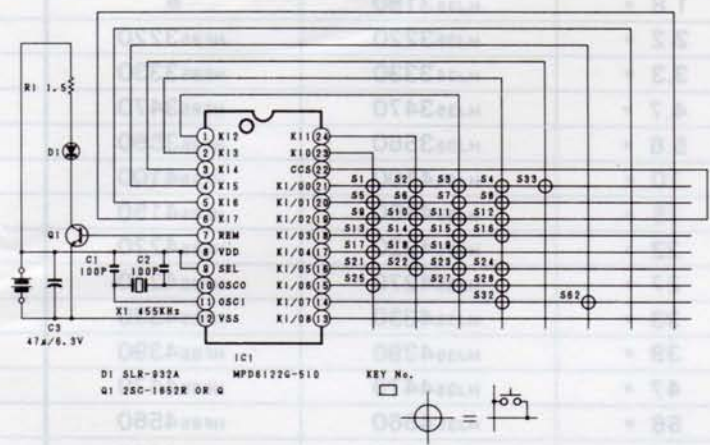

KEY No.	DATA CODE								FUNCTION
	D0	D1	D2	D3	D4	D5	D6	D7	
1	0	0	0	0	0	0	0	0	DECK PLAY
2	1	0	0	0	0	0	0	0	DECK REW
3	0	1	0	0	0	0	0	0	DECK FF
4	1	1	0	0	0	0	0	0	DECK STOP
5	0	0	1	0	0	0	0	0	DECK REC PAUSE
6	1	0	1	0	0	0	0	0	DECK REC MUTE
7	0	1	1	0	0	0	0	0	DECK DECK A/B
8	1	1	1	0	0	0	0	0	DECK DIR. A
9	0	0	0	1	0	0	0	0	CD PLAY
10	1	0	0	1	0	0	0	0	CD PAUSE/STOP
11	0	1	0	1	0	0	0	0	CD SKIP ⏩
12	1	1	0	1	0	0	0	0	CD SKIP ⏪
13	0	0	1	1	0	0	0	0	CD SEARCH ⏭
14	1	0	1	1	0	0	0	0	CD SEARCH ⏬
15	0	1	1	1	0	0	0	0	PLAYER PLAY/CUT
16	1	1	1	1	0	0	0	0	AMP VCR

KEY No.	DATA CODE								FUNCTION
	D0	D1	D2	D3	D4	D5	D6	D7	
17	0	0	0	0	1	0	0	0	TUNER PRESET UP
18	1	0	0	0	1	0	0	0	TUNER PRESET DOWN
19	0	1	0	0	1	0	0	0	TUNER P1-8/P9-16
21	0	0	1	0	1	0	0	0	AMP PHONO
22	1	0	1	0	1	0	0	0	AMP CD
23	0	1	1	0	1	0	0	0	AMP TUNER
24	1	1	1	0	1	0	0	0	AMP CDV
25	0	0	0	1	1	0	0	0	AMP TAPE
27	0	1	0	1	1	0	0	0	VOL. UP
28	1	1	0	1	1	0	0	0	VOL. DOWN
32	1	1	1	1	1	0	0	0	POWER ON/OFF
33	0	0	0	0	0	0	1	0	DECK DIR. B
62	1	0	1	1	1	0	1	0	CD DISC
	C0	C1	C2	C3	C4	C5	C6	C7	CUSTOM CODE
	0	1	0	1	1	1	1	0	

PARTS LIST

Ref. No.	Part No.	Description	部 品 名	Remarks	Common Model	Markets	ランク
	VH 04 18 00	Remote Control Transmitter	リモートコントロールトランスミッター	AV-50, A-45			
	VH 04 16 00	//	//	A-40			
I	CX 60 72 00	Lid	電池 ケ ー ス		K-PM1-562-01		
		Dry Cell	単 4 乾 電 池				

※New Parts (新規部品) NR

Parts List for Carbon Resistors

Value	1/4W Type Part No.	1/6W Type Part No.	Value	1/4W Type Part No.	1/6W Type Part No.
1.0 Ω	HJ353100	HF853100	12K Ω	HJ357120	HF857120
1.8 "	HJ353180	*	15 "	HJ357150	HF857150
2.2 "	HJ353220	HF853220	18 "	HJ357180	HF857180
3.3 "	HJ353330	HF853330	22 "	HJ357220	HF857220
4.7 "	HJ353470	HF853470	27 "	HJ357270	HF857270
5.6 "	HJ353560	HF853560	33 "	HJ357330	HF857330
10 "	HJ354100	HF854100	39 "	HJ357390	HF857390
15 "	HJ354150	HF854150	47 "	HJ357470	HF857470
22 "	HJ354220	HF854220	56 "	HJ357560	HF857560
27 "	HJ354270	HF854270	68 "	HJ357680	HF857680
33 "	HJ354330	HF854330	82 "	HJ357820	HF857820
39 "	HJ354390	HF854390	91 "	HJ357910	HF857910
47 "	HJ354470	HF854470	100 "	HJ358100	HF858100
56 "	HJ354560	HF854560	120 "	HJ358120	HF858120
68 "	HJ354680	HF854680	150 "	HJ358150	HF858150
82 "	HJ354820	HF854820	180 "	HJ358180	HF858180
100 "	HJ355100	HF855100	220 "	HJ358220	HF858220
110 "	HJ355110	HF855110	270 "	HJ358270	HF858270
120 "	HJ355120	HF855120	330 "	HJ358330	HF858330
150 "	HJ355150	HF855150	390 "	HJ358390	HF858390
160 "	HJ355160	*	470 "	HJ358470	HF858470
180 "	HJ355180	HF855180	560 "	HJ358560	HF858560
220 "	HJ355220	HF855220	680 "	HJ358680	HF858680
270 "	HJ355270	HF855270	820 "	HJ358820	HF858820
330 "	HJ355330	HF855330	1.0M Ω	HJ359100	HF859100
390 "	HJ355390	HF855390	1.2 "	HJ359120	*
470 "	HJ355470	HF855470	1.5 "	HJ359150	HF859150
510 "	*	HF855510	1.8 "	HJ359180	HF859180
560 "	HJ355560	HF855560	2.2 "	HJ359220	HF859220
680 "	HJ355680	HF855680	3.3 "	HJ359330	HF859330
820 "	HJ355820	HF855820	3.9 "	HJ359390	*
910 "	HJ355910	HF855910	4.7 "	HJ359470	HF859470
1.0K Ω	HJ356100	HF856100			
1.2 "	HJ356120	HF856120			
1.5 "	HJ356150	HF856150			
1.8 "	HJ356180	HF856180			
2.0 "	HJ356200	HF856200			
2.2 "	HJ356220	HF856220			
2.4 "	HJ356240	HF856240			
2.7 "	HJ356270	HF856270			
3.0 "	HJ356300	HF856300			
3.3 "	HJ356330	HF856330			
3.6 "	HJ356360	HF856360			
3.9 "	HJ356390	HF856390			
4.7 "	HJ356470	HF856470			
5.1 "	HJ356510	HF856510			
5.6 "	HJ356560	HF856560			
6.8 "	HJ356680	HF856680			
8.2 "	HJ356820	HF856820			
9.1 "	HJ356910	HF856910			
10 "	HJ357100	HF857100			

