



Loopfactory
AN200

SERVICE MANUAL



■ **CONTENTS**

SPECIFICATIONS 3

PANEL LAYOUT 4

CIRCUIT BOARD LAYOUT 6

WIRING 6

BLOCK DIAGRAM 7

DISASSEMBLY PROCEDURE 8

LSI PIN DISCRPTION 11

IC BLOCK DIAGRAM 15

DIMENSIONS 17

CIRCUIT BOARDS 18

TEST PROGRAM & INITIALIZE 28

MIDI IMPLEMENTATION CHART 40

PARTS LIST

OVERALL CIRCUIT DIAGRAM

This document is printed on chlorine free (ECF) paper with soy ink.

IMPORTANT NOTICE

This manual has been provided for the use of authorized Yamaha Retailers and their service personnel. It has been assumed that basic service procedures inherent to the industry, and more specifically Yamaha Products, are already known and understood by the users, and have therefore not been restated.

WARNING: Failure to follow appropriate service and safety procedures when servicing this product may result in personal injury, destruction of expensive components and failure of the product to perform as specified. For these reasons, we advise all Yamaha product owners that all service required should be performed by an authorized Yamaha Retailer or the appointed service representative.

IMPORTANT: This presentation or sale of this manual to any individual or firm does not constitute authorization, certification, recognition of any applicable technical capabilities, or establish a principal-agent relationship of any form.

The data provided is believed to be accurate and applicable to the unit(s) indicated on the cover. The research engineering, and service departments of Yamaha are continually striving to improve Yamaha products. Modifications are, therefore, inevitable and changes in specification are subject to change without notice or obligation to retrofit. Should any discrepancy appear to exist, please contact the distributor's Service Division.

WARNING: Static discharges can destroy expensive components. Discharge any static electricity your body may have accumulated by grounding yourself to the ground bus in the unit (heavy gauge black wires connect to this bus).

IMPORTANT: Turn the unit OFF during disassembly and parts replacement. Recheck all work before you apply power to the unit.

WARNING: CHEMICAL CONTENT NOTICE!

The solder used in the production of this product contains LEAD. In addition, other electrical / electronic and / or plastic (where applicable) components may also contain traces of chemicals found by the California Health and Welfare Agency (and possibly other entities) to cause cancer and / or birth defects or other reproductive harm.

DO NOT PLACE SOLDER, ELECTRICAL / ELECTRONIC OR PLASTIC COMPONENTS IN YOUR MOUTH FOR ANY REASON WHAT SO EVER!

Avoid prolonged, unprotected contact between solder and your skin! When soldering, do not inhale solder fumes or expose eyes to solder / flux vapor!

If you come in contact with solder or components located inside the enclosure of this product, wash your hands before handling food.

LITHIUM BATTERY HANDLING

This product uses a lithium battery for memory back-up.

WARNING: Lithium batteries are dangerous because they can be exploded by improper handling. Observe the following precautions when handling or replacing lithium batteries.

- Leave lithium battery replacement to qualified service personnel.
- Always replace with batteries of the same type.
- When installing on the PC board by soldering, solder using the connection terminals provided on the battery cells.
- Never solder directly to the cells. perform the soldering as quickly as possible.
- Never reverse the battery polarities when installing.
- Do not short the batteries.
- Do not attempt to recharge these batteries.
- Do not disassemble the batteries.
- Never heat batteries or throw them into fire.

ADVARSEL!

Lithiumbatteri–Eksplosionsfare ved fejlagtig håndtering. Udskiftning må kun ske med batteri af samme fabrikat og type. Levér det brugte batteri tilbage til leverandoren.

VARNING

Explosionsfara vid felaktigt batteribyte. Använd samma batterityp eller en ekvivalent typ som rekommenderas av apparattillverkaren. Kassera använt batteri enligt fabrikantens instruktion.

VAROITUS

Paristo voi räjähtää, jos se on virheellisesti asennettu. Vaihda paristo ainoastaan laitevalmistajan suosittelemaan tyyppiin. Hävitä käytetty paristo valmistajan ohjeiden mukaisesti.

The following information complies with Dutch Official Gazette 1995. 45; ESSENTIALS OF ORDER ON THE COLLECTION OF BATTERIES.

- Please refer to the disassembly procedure for the removal of Back-up Battery.
- Leest u voor het verwijderen van de backup batterij deze beschrijving.

■ SPECIFICATIONS

1. FUNCTIONS

Tone Generator	Analog Physical Modeling 2VCO (Osc. Sync, FM), Noise, Ring Mod., Filter (FEG), Amp (AEG), 2LFO, PEG + AWM2
Timber	1 (AN) + 3 (AWM2)
Polyphony	5 (AN) + 32 (AWM2) Notes
Effector	Distortion, 3-Band EQ (only AN) + 1 Effector (Tempo Delay/Reverb, Flanger/ Chorus, Phaser, Amp. Simulator)
Pattern	Preset Pattern x 256, User Pattern x 128
Scene	2 Scene
Step Sequencer	MIDI Sync, MIDI Transmit
Others	Free EG (4 tracks)

2. CONTROLLERS

Sound Control Knob	x 16 (Cutoff/Filter Type, Resonance, FEG Depth, VCO1/2 Balance, FM Depth, Sync Pitch, Noise Level, EG Attack, EG Decay, EG Sustain, EG Release, Portamento Time, Effect Param/ Pan, Effect Wet/Vol, LFO Speed, Scene Control)
Master Volume Knob	x 1
Rotary Encoder	x 1

3. PANEL SWITCHES

Sound Control Sw.	x 8 (LFO Detail, Key Assign, VCO1 Wave, Sync Mode, VCO2 Wave, Effect Type, EG Select, Dist Sw)
Scene x 2, Sequencer. Sw x 2, Mode x 2, Pattern Select x 1, Keyboard Mode x 1, Step Select x 16, Step Group Select x 2, Track Select x 2, Play Effect x 2, Octave x 2, Tap Tempo x 1, Free EG Sw. x 4, Free EG Mode x 1, Free EG Length x 1, Store x 1, Show Value x 1, Shift x 1, Exit x 1	

4. DISPLAY

7SEG LED	x 4
----------	-----

5. CONNECTORS

OUTPUT L (MONO)/R	Phone x 2
MIDI IN/OUT	Din x 2
DC IN	
PHONES	Stereo phone

6. MAXIMUM OUTPUT LEVEL

Phones	+0.5 dBm (33 ohm)
Stereo Output	+9.0 dBm (10 kohm)

7. IMPEDANCE

Phones	47Ω
OUTPUT L/R	1kΩ

8. POWER CONSUMPTION

7.4W (DEMO PLAY)
340mA ±10%

9. DIMENSIONS, WEIGHT

338.0 (W) x 208.9 (D) x 51.7 (H) mm, 1600 g

10. ACCESSORIES

CD ROM (for Windows and Macintosh)	x 1
Owner's Manual	x 1
AC Adaptor	x 1

(Power supply recommendation may vary from country to country. Please check with your nearest Yamaha dealer for further details.)

■ PANEL LAYOUT

• Top Panel

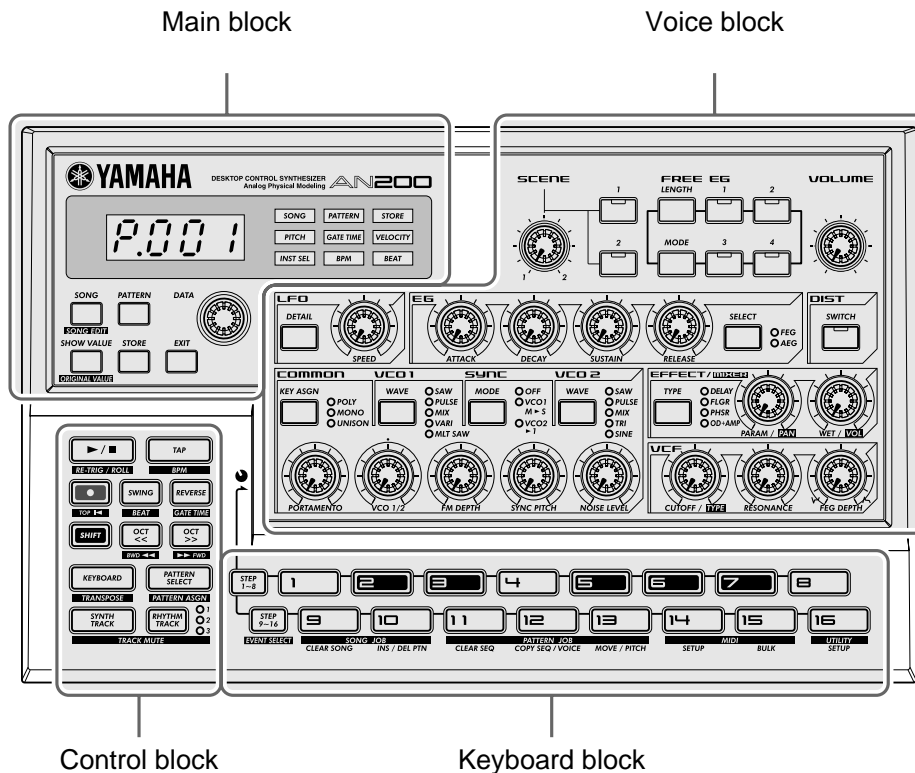

Main Block

- [SONG] button
- [PATTERN] button
- [DATA] knob
- [SHOW VALUE] button
- [STORE] button
- [EXIT] button

VOICE BLOCK

- [SCENE] group
 - [SCENE] knob
 - [1] button
 - [2] button
- [FREE EG] group
 - [LENGTH] button
 - [1] button
 - [2] button
 - [MODE] button
 - [3] button
 - [4] button
- [VOLUME] knob
- [LFO] group
 - [DETAIL] button
 - [SPEED] knob
- [EG] group
 - [ATTACK] knob
 - [DECAY] knob
 - [SUSTAIN] knob

[RELEASE] knob
 [SELECT] button
 [DIST] group
 [SWITCH] button
 [COMMON] group
 [KEY ASGN] button
 [VCO1] group
 [WAVE] button
 [SYNC] group
 [MODE] button
 [VCO 2] group
 [WAVE] button
 [PORTAMENTO] knob
 [VCO 1/2] knob
 [FM DEPTH] knob
 [SYNC PITCH] knob
 [NOISE LEVEL] knob
 [EFFECT] group
 [TYPE] button
 [PARAM / PAN] knob
 [WET / VOL] knob
 [VCF] group
 [CUTOFF / TYPE] knob
 [RESONANCE] knob
 [FEG DEPTH] knob

CONTROL BLOCK

[▶ / ■] (START / STOP) button
 [TAP] button
 [●] button
 [SWING] button
 [REVERSE] button
 [SHIFT] button
 [OCT <<] button
 [OCT >>] button
 [KEYBOARD] button
 [PATTERN SELECT] button
 [SYNTH TRACK] button
 [RHYTHM TRACK] button

KEYBOARD BLOCK

• Rear Panel

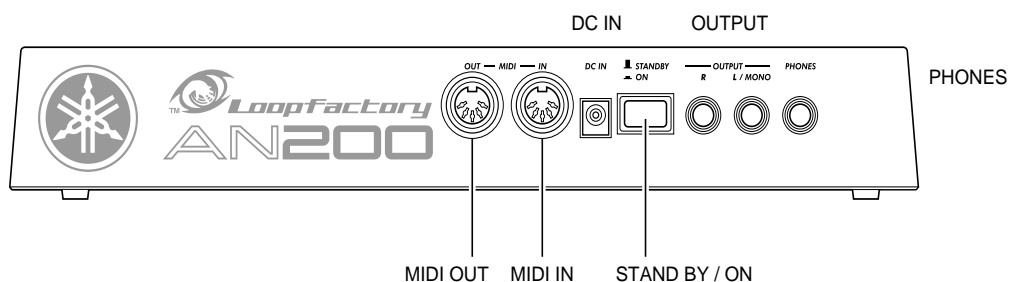

■ CIRCUIT BOARD LAYOUT

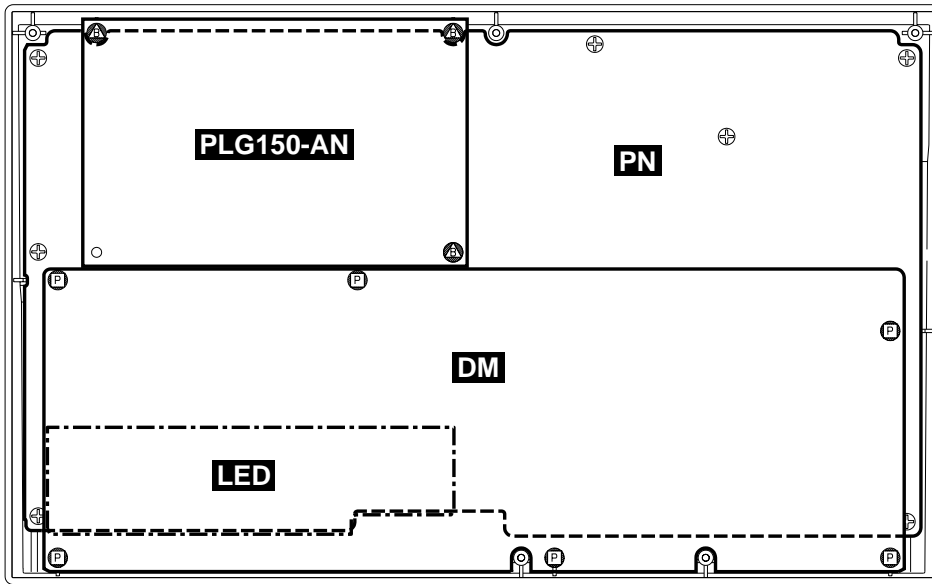

■ WIRING

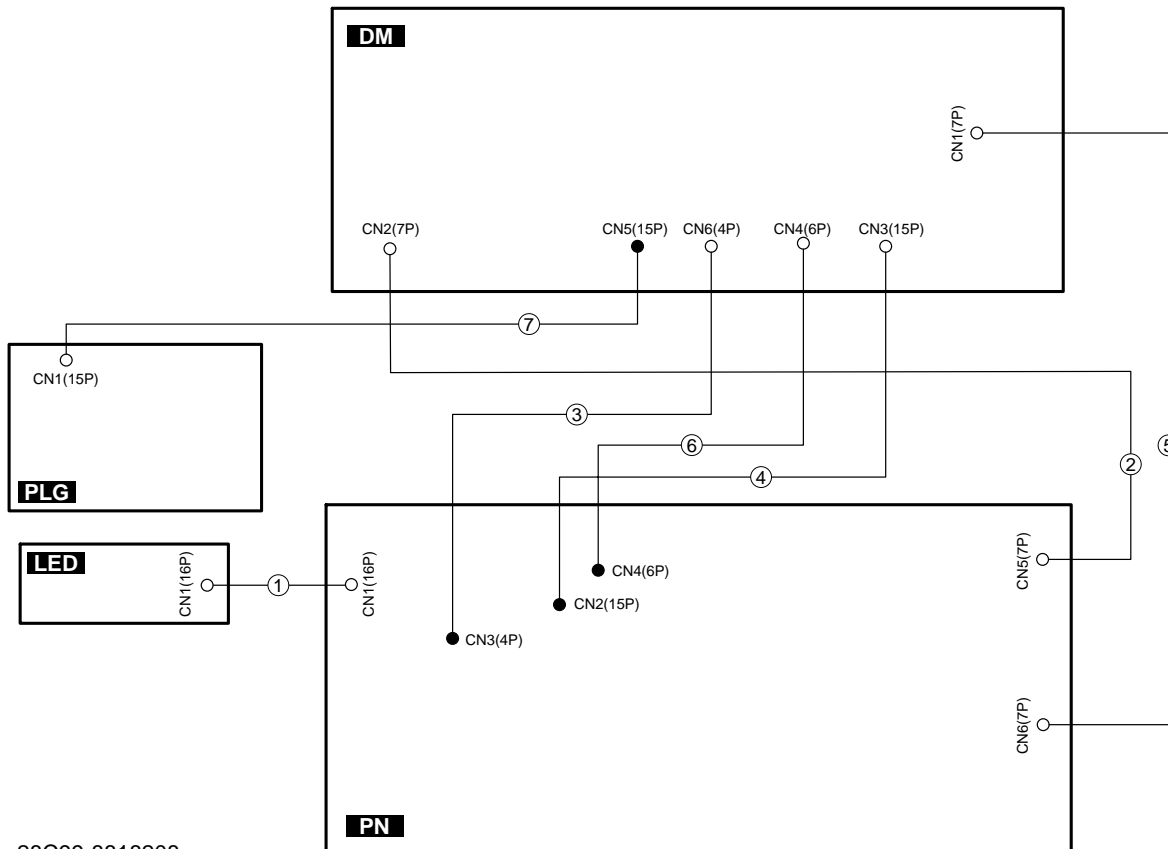

28C99-8818208

LOCATION	CONNECTOR NAME	PIN/LENGTH	DESTINATION	
①		16P / L=80	PN-CN1	LED-CN1
②	KR-KR	7P / L=450	DM-CN2	PN-CN5
③	DS-KR	4P / L=380	DM-CN6	PN-CN3
④	DS-KR	15P / L=220	DM-CN3	PN-CN2
⑤	KR-KR	7P / L=150	DM-CN1	PN-CN6
⑥	DS-KR	6P / L=200	DM-CN4	PN-CN4
⑦	PLG-DM	15P / L=50	DM-CN5	PLG_AN-CN1

■ BLOCK DIAGRAM

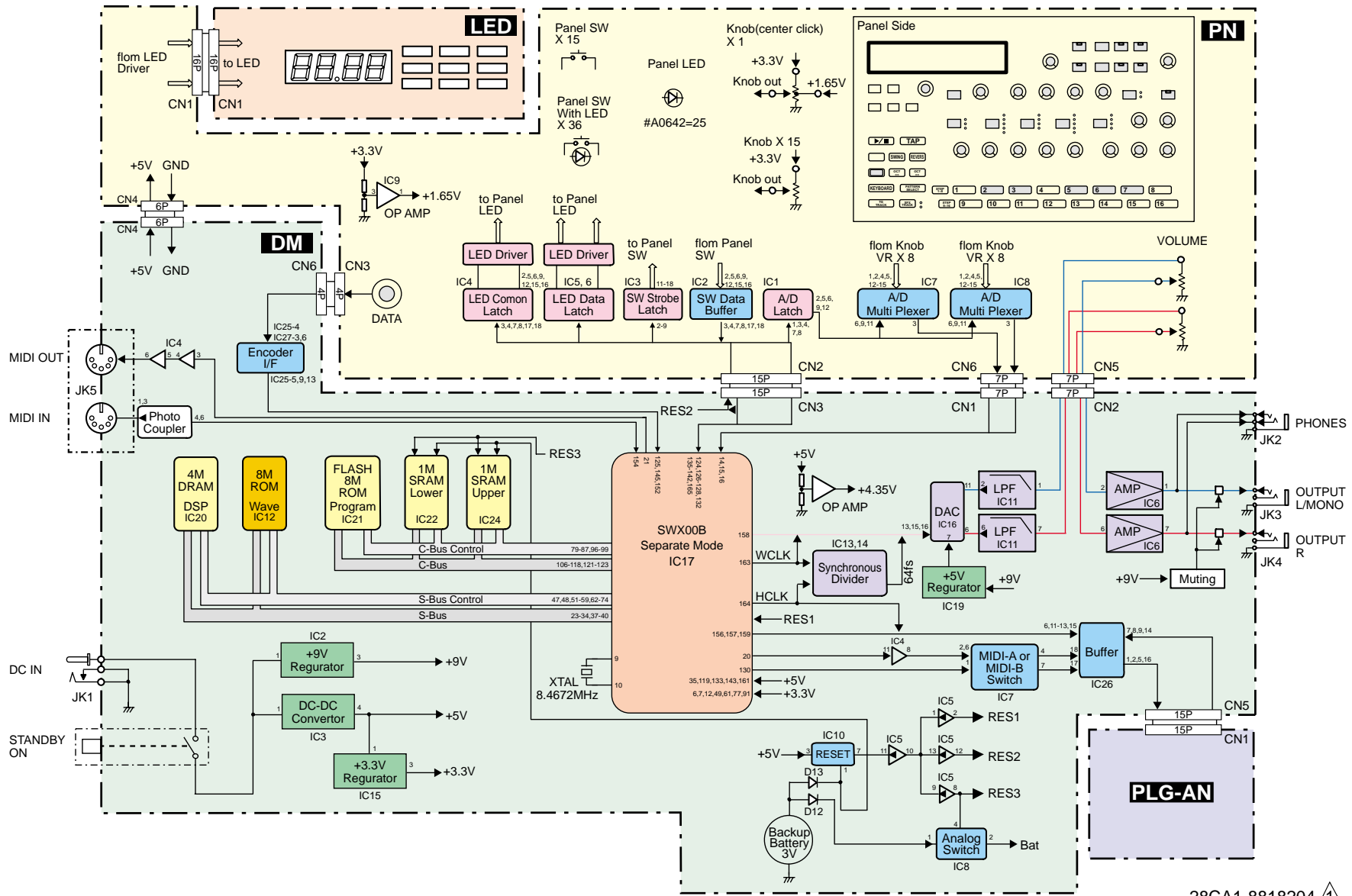

28CA1-8818204

■ DISASSEMBLY PROCEDURE

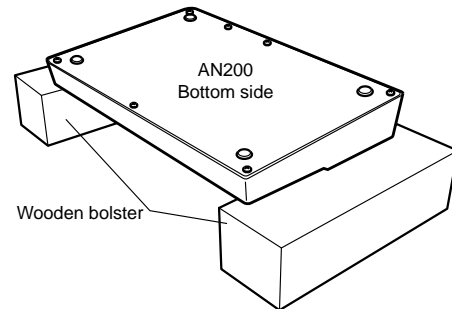
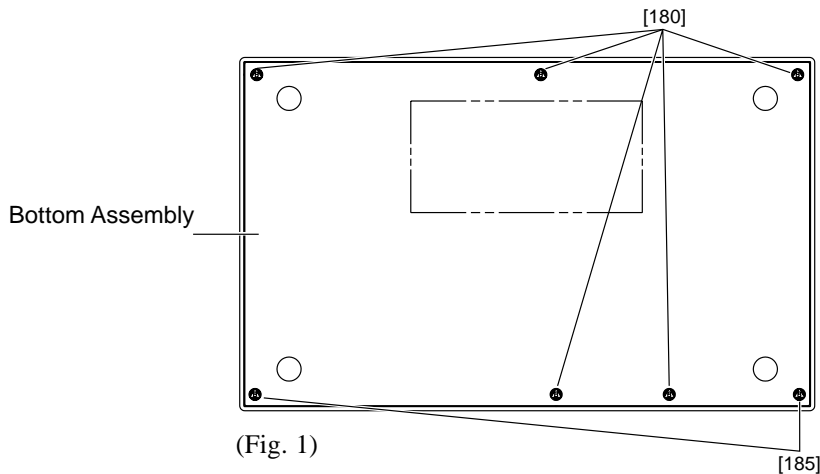

[180]: Bind Head Tapping Screw-B 3.0X6 MFZN2Y (EP600130)

[185]: Bind Head Tapping Screw-B 3.0X6 MFZN2Y (EP600130)

1. Bottom Assembly (time required: about 1 min)

- 1-1 Remove the five (5) screws marked [180] and the two (2) screws marked [185]. The bottom assembly can then be removed. (Fig. 1)

- * If you turn the mixer upside down for disassembling and assembling, put 2 wooden bolsters underneath the unit at its both side ends to protect the PN circuit board from being damaged. (Fig. 1-1)

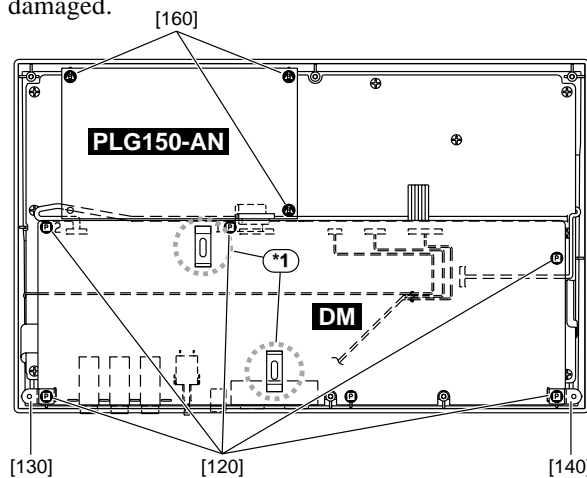

[120]: Bind Head Tapping Screw-P 2.6X8 MFZN2Y (EP620100)

[130]: Angle, L (V655450)

[140]: Angle, R (V655460)

[160]: Bind Head Tapping Screw-B 3.0X86 MFZN2Y (EP620130)

2. PLG150-AN Circuit Board (time required: about 1 min)

- 2-1 Remove the bottom assembly. (See Procedure 1.)
2-1 Remove the three (3) screws marked [160]. The PLG150-AN circuit board can then be removed. (Fig. 2)

- * Attachment consideration of the PLG150-AN circuit board. When installing the PLG150-AN circuit board, do with connector assembly as shown in the fig 2-1. Fit the PLG150-AN circuit board caring not to let the connector assembly in it.

3. DM Circuit Board (time required: about 2 min)

- 3-1 Remove the bottom assembly. (See Procedure 1.)
- 3-2 Remove the PLG150-AN circuit Board. (See Procedure 2.)
- 3-3 Remove the six (6) screws marked [120]. The DM circuit board can then be removed. (Fig. 2)

* Attachment consideration of the DM circuit board
 Confirm that the DM contact terminal [110b], which is on the backside of the DM circuit board, is not distorted or bent. Contact it appropriately on the bottom board assembly. Replace any terminal when it is bent or broken. (Fig. 2-2)

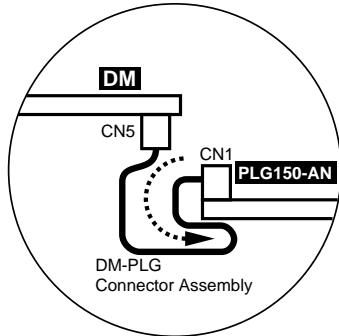

(Fig. 2-1)

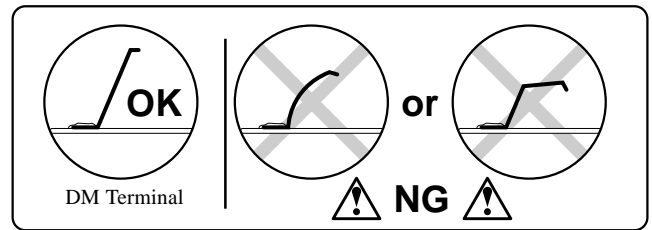

(Fig. 2-2)

[100b]: DM Terminal (V7450500)

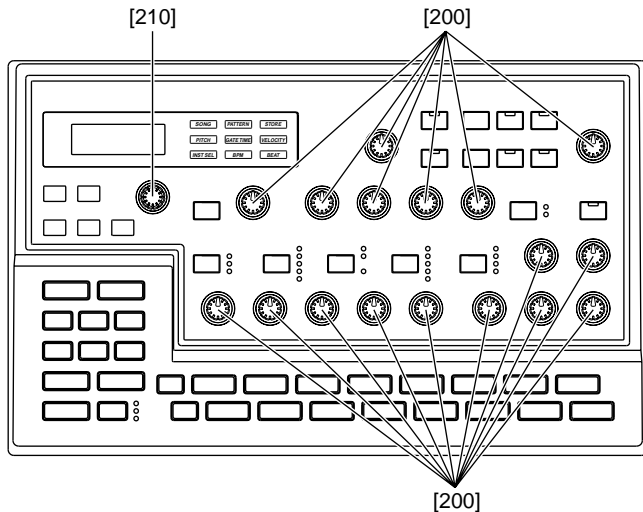

(Fig. 3)

[200]: Knob K-CB (V4765800)
 [210]: Knob (VU931600)

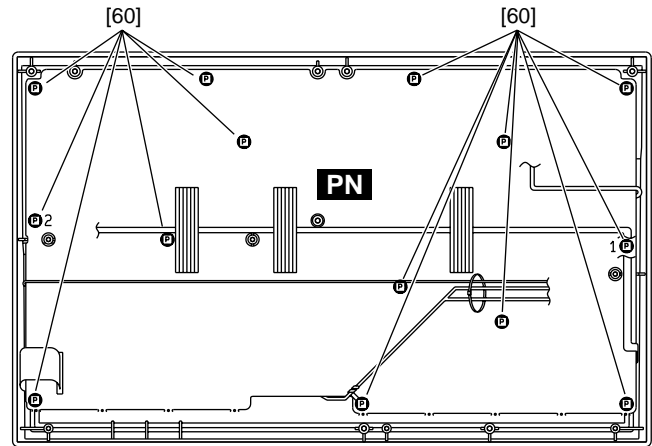

(Fig. 4)

[60]: Bind Head Tapping Screw-P 2.6X8 MFZN2Y (EP620100)

4. PN Circuit Board (time required: about 4 min)

- 4-1 Remove the bottom assembly. (See Procedure 1.)
- 4-2 Remove the PLG150-AN circuit Board. (See Procedure 2.)
- 4-3 Remove the DM circuit Board. (See Procedure 3.)
- 4-4 Remove the seventeen (17) knobs marked [200] and one (1) knob marked [210]. (Fig. 3)
- 4-5 Remove the fourteen (14) screws marked [60]. The PN circuit board can then be removed. (Fig. 4)

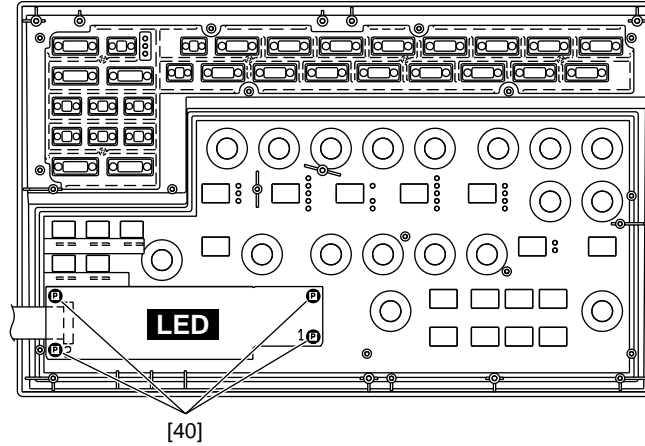

(Fig. 5)

[40]: Bind Head Tapping Screw-P 2.6X8 MFZN2Y (EP620100)

5. LED Circuit Board (time required: about 5 min)

- 5-1 Remove the bottom assembly. (See Procedure 1.)
- 5-2 Remove the PLG150-AN circuit Board. (See Procedure 2.)
- 5-3 Remove the DM circuit Board. (See Procedure 3.)
- 5-4 Remove the PN circuit Board. (See Procedure 4.)
- 5-5 Remove the four (4) screws marked [40]. The LED circuit board can then be removed. (Fig. 5)

Battery VN103500

VN103600 (Battery holder for VN103500)

- Notice for back-up battery removal push the battery as shown in figure, then the battery will pop up.
- Druk de batterij neer beneden zoals aangeven in de tekening, de batterij springt dan neer voren.

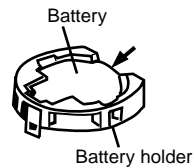

■ LSI PIN DISCRPTION

● HG73C205AFD (XU947C00) SWX00B TONE GENERATOR

DM: IC17

PIN NO.	NAME	I/O	FUNCTION	PIN NO.	NAME	I/O	FUNCTION	
1	ICN	I	Initial clear	85	CMA3	O	Program address bus	
2	RFCLKI	I	PLL Clock	86	CMA8	O		
3	TM2	I	PLL Control	87	CMA2	O		
4	AVDD_PLL		Power supply	88	CRD	O	read signal	
5	AVSS_PLL		Ground	89	CMA1	O	Program address bus	
6	MODE0	I	SWX dual mode	90	CUB	O	high byte effective signal	
7	VCC7		Power supply	91	VCC91		Power supply	
8	GND8		Ground	92	GHND92		Ground	
9	XIN	I	crystal oscillator	93	CS1	O	CS signal	
10	XOUT	O	crystal oscillator	94	CMA0	O	Program address bus	
11	MODE1	I	SWX separate mode	95	CLB	O	low byte effective signal	
12	TEST0	I	TEST pin	96	CMA12	O	Program address bus	
13	TESTON	I	TEST pin	97	CMA11	O		
14	AN0-P40	I	A/D converter	98	CMA10	O		
15	AN1-P41	I						
16	AN2-P42	I						
17	AN3-P43	I						
18	AVDD_AN		Power supply	100	GND100		Ground	
19	AVSS_AN		Ground	101	CWE	O	write signal	
20	TXD0	O	for MIDI or TO-HOST	102	CMA16	O	Program address bus	
21	TXD1	O	for MIDI	103	CMA15	O		
22	EXCLK	I	Crystal oscillator	104	CMA14	O		
23	SMD11	I/O	Wave memory data bus	105	CMA13	O	Program memory Data bus	
24	SMD4	I/O						
25	SMD3	I/O						
26	SMD12	I/O						
27	SMD10	I/O						
28	SMD5	I/O						
29	SMD2	I/O						
30	SMD13	I/O						
31	SMD9	I/O						
32	SMD6	I/O						
33	SMD1	I/O						
34	SMD14	I/O						
35	VCC35			Power supply	106	CMD8		I/O
36	GND36			Ground	107	CMD7		I/O
37	SMD8	I/O	Wave memory data bus	108	CMD9	I/O		
38	SMD7	I/O						
39	SMD0	I/O						
40	SMD15	I/O						
41	SOE	O	read signal	109	CMD6	I/O		
42	SWE	O	write signal	110	CMD10	I/O		
43	SRAS	O	RAS signal	111	CMD5	I/O		
44	SCAS	O	CAS signal	112	CMD11	I/O		
45	REFRESH	O	REFRESH signal	113	CMD4	I/O		
46	CS0	O	CS signal	114	CMD12	I/O		
47	SMA0	O	Memory address bus	115	CMD3	I/O		
48	SMA16	O	Memory address bus	116	CMD13	I/O		
49	VCC49			Power supply	117	CMD2	I/O	
50	GND50			Ground	118	CMD14	I/O	
51	SMA1	O						
52	SMA15	O						
53	SMA2	O						
54	SMA14	O						
55	SMA3	O						
56	SMA13	O						
57	SMA4	O						
58	SMA12	O						
59	SMA5	O	Power supply	119	VCC119			
60	GND60			Ground	120	GND115		
61	VCC61			Power supply	121	CMD1	I/O	
62	SMA11	O	Memory address bus	122	CMD15	I/O	Program memory Data bus	
63	SMA6	O						
64	SMA10	O						
65	SMA7	O						
66	SMA9	O						
67	SMA17	O						
68	SMA8	O						
69	SMA18	O						
70	SMA19	O						
71	SMA20	O						
72	SMA21	O	SWX access data bus	123	CMD0	I/O		
73	SMA22	O						
74	SMA23	O						
75	CMA20	O	Program address bus	124	CMA21	O	Program address bus	
76	CMA19	O						
77	VCC77		Power supply	125	PDT15	I/O	SWX access data bus	
78	GND78		Ground	126	PDT14	I/O		
79	CMA18	O	Program address bus	127	PDT13	I/O		
80	CMA17	O						
81	CMA5	O						
82	CMA6	O						
83	CMA4	O						
84	CMA7	O						
				Ground	128	PDT12	I/O	
				Power supply	129	PDT11	I/O	
				Ground	130	PDT10	I/O	
				Power supply	131	PDT9	I/O	
			Ground	132	PDT8	I/O		
			Power supply	133	VCC133			
			Ground	134	GND134			
			SWX access address bus	135	PDT7	I/O		
				Power supply	136	PDT6	I/O	
				Ground	137	PDT5	I/O	
				Power supply	138	PDT4	I/O	
				Ground	139	PDT3	I/O	
				Power supply	140	PDT2	I/O	
			SWX access data bus	141	PDT1	I/O		
				Ground	142	PDT0	I/O	
				Power supply	143	VCA143		
			Ground	144	GND144			
			SWX access data bus	145	PAD2	I		
				Power supply	146	PAD1	I	
			Ground	147	PAD0	I		
			Power supply	148	VCC148			
			Ground	149	GND149			
			Chip select	150	PCS	I		
			write enable	151	PWR	I		
			read enable	152	PRD	I		
			for Midi or TO-HOST	153	RXD0	I		
			for Midi or Key scan	154	RXD1	I		
			EXT Clock	155	SCLKI	I		
			A/D converter	156	ADIN	I		
			A/D converter LR clock	157	ADLR	O		
			DAC	158	DO0	O		
			1/2 clock	159	DO1	O		
			Power supply	160	SYSCCLK	O		
			Ground	161	VCC161			
			for DAC LR clock	162	GND162			
			1/12 clock	163	WCLK	O		
			IIS-DAC clock	164	QCLK	O		
			Synch signal	165	BCLK	O		
			Interrupt request	166	SYI	I		
				167	IRQ0	I		
				168	NMI	I		

• YSS236-F (XT013A00) VOP3

PLG150-AN: IC4

PIN NO.	NAME	I/O	FUNCTION	PIN NO.	NAME	I/O	FUNCTION		
1	VSS		Power supply	81	SO7	O			
2	WA17	O		82	SO6	O	Serial output		
3	WA16	O		83	SO5	O			
4	WA15	O		84	VDD		Ground		
5	WA14	O	External memory address bus	85	VSS		Power supply		
6	WA13	O			86	SO4	O		
7	WA12	O			87	SO3	O		
8	WA11	O			88	SO2	O	Serial output	
9	WA10	O			89	SO1	O		
10	VDD		Ground	90	SO0	O			
11	VSS		Power supply	91	WDCK	O	Data enable for DAC		
12	WA09	O		92	SWPKON	O	SWP00 format key on output		
13	WA08	O		93	IRQN	O	EG interrupt		
14	WA07	O		94	VDD		Ground		
15	WA06	O	External memory address bus	95	VSS		Power supply		
16	WA05	O			96	XTAL_I	I	Quartz crystal terminal	
17	WA04	O			97	XTAL_O	O	Quartz crystal terminal	
18	WA03	O			98	MCLK	O	Oscillate clock output	
19	WA02	O			99	VDD		Ground	
20	VDD		Ground	100	VSS		Power supply		
21	VSS		Power supply	101	MICN	I	Initial clear		
22	WA01	O	External memory address bus	102	CLKIN	I	Master clock input		
23	WA00	O			103	SYWIN	I	Sync.signal input	
24	WEN	O		External memory control (WEN)	104	SYW	O	Sync.signal output	
25	OEN	O	External memory control (OEN)	105	SYWD	O	Sync.signal output		
26	RASN	O	External memory control (RASN)	106	VDD		Ground		
27	CASN	O	External memory control (CASN)	107	VSS		Power supply		
28	CEN	O	External memory control (CEN)	108	CLKO	O	For test (512 fs output)		
29	VDD		Ground	109	WCLK	O	2 times sync.clock output (256fs)		
30	VSS		Power supply	110	HCLK	O	4 times sync.clock output (128fs)		
31	WD19	I/O	External memory data bus	111	QCLK	O	8 times sync.clock output (64fs)		
32	WD18	I/O			112	TSTCI	I	PLL test input	
33	WD17	I/O			113	VDD		Ground	
34	WD16	I/O			114	VSS		Power supply	
35	WD15	I/O			115	(NC)			
36	WD14	I/O			116	VDD(PLL)			
37	VDD			Ground	117	CPO	O	PLL control output	
38	VSS		Power supply	118	CPIN	I	PLL control input		
39	WD13	I/O	External memory data bus	119	REF	I	PLL control input		
40	WD12	I/O			120	VSS(PLL)			
41	WD11	I/O			121	(NC)			
42	WD10	I/O			122	VDD		Ground	
43	WD09	I/O			123	VSS		Power supply	
44	WD08	I/O			124	TSTCS	I	PLL test input	
45	WD07	I/O			125	CA6	I		
46	VDD			Ground	126	CA5	I		
47	VSS		Power supply	127	CA4	I	CPU address bus		
48	WD06	I/O	External memory data bus	128	CA3	I			
49	WD05	I/O			129	CA2	I		
50	WD04	I/O			130	VDD		Ground	
51	WD03	I/O			131	VSS		Power supply	
52	WD02	I/O			132	CA1	I	CPU address bus	
53	WD01	I/O			133	CA0	I	Lo/Hi select in 8 bits write	
54	WD00	I/O			134	CSN	I	Chip select	
55	VDD		Ground	135	RDN	I	Register read		
56	VSS		Power supply	136	WRN	I	Register write		
57	TST2	O	Test output	137	BTYP		Data bus type select		
58	TST1	O			138	VDD		Ground	
59	TST0	O			139	VSS		Power supply	
60	MS	I	Memory select	140	CD15	I/O	CPU data bus		
61	LRCLK	O	LR clock for ADC	141	CD14	I/O			
62	SI7	I	OSerial input	142	CD13	I/O			
63	SI6	I		143	CD12	I/O			
64	VDD		Ground	144	CD11	I/O			
65	VSS		Power supply	145	VDD		Ground		
66	SI5	I	Serial input	146	VSS		Power supply		
67	SI4	I			147	CD10	I/O	CPU data bus	
68	SI3	I			148	CD09	I/O		
69	SI2	I			149	CD08	I/O		
70	SI1	I			150	CD07	I/O		
71	SI0	I		151	CD06	I/O			
72	DB1	I	Output bit type select for DAC	152	CD05	I/O			
73	DB0	I			153	VDD		Ground	
74	VDD		Ground	154	VSS		Power supply		
75	VSS		Power supply	155	CD04	I/O	CPU data bus		
76	ODFM	I	Output mode select for DAC	156	CD03	I/O			
77	OFS3	I	Serial output format select	157	CD02	I/O			
78	OFS2	I			158	CD01		I/O	
79	OFS1	I			159	CD00	I/O		
80	OFS0	I			160	VDD		Ground	

• HD6413002FP16 (XQ375A00) CPU

PLG150-AN: IC1

PIN NO.	NAME	I/O	FUNCTION	PIN NO.	NAME	I/O	FUNCTION	
1	PA6	O	Port A	51	A12	O	Address bus	
2	PA7	O	Address bus	52	A13	O		
3	VCC		Power supply	53	A14	O		
4	PB0	I	Port B	54	A15	O		
5	PB1	I						
6	PB2	I						
7	PB3	I						
8	PB4	I						
9	PB5	I						
10	PB6//DREQ0	I	Port 6	59	VSS			Ground
11	PB7//DREQ1	I						
12	/RESO	O		Reset	60	P60//WAIT	I	
13	VSS		Ground	61	P61//BREQ	I	Oout	
14	P90/TXD0	O	Transmit data (MIDI OUT)	62	P62//BACK	I		
15	P91/TXD1	O	KSN-ACK	63	O	O	Stand-by mode signal	
16	P92/RXD0	I	Receive data (MIDI IN)	64	/STBY	I	Reset	
17	P93/RXD1	I	KSN-RX	65	/RES	I	Non-maskable interrupt	
18	P94/SCK0	O	Port 9	66	NMI	I	Ground	
19	P95/SCK1	I	Port 9	67	VSS		Ground	
20	P40/D0	I/O	Data bus	68	EXTAL	I	Clock	
21	P41/D1	I/O						
22	P42/D2	I/O						
23	P43/D3	I/O						
24	VSS			Ground	69	XTAL	O	Clock
25	P44/D4	I/O						
26	P45/D5	I/O						
27	P46/D6	I/O	Mode select	70	VCC		Power supply	
28	P47/D7	I/O						
29	D8	I/O						
30	D9	I/O	Analog power supply	71	/AS	O	Address strobe	
31	D10	I/O						
32	D11	I/O						
33	D12	I/O						
34	D13	I/O						
35	D14	I/O						
36	D15	I/O						
37	VCC			Power supply	72	/RD	O	Read strobe
38	A0	O		Address bus	73	/HWR	O	Write strobe (High)
39	A1	O						
40	A2	O						
41	A3	O						
42	A4	O						
43	A5	O						
44	A6	O						
45	A7	O						
46	VSS		Ground		74	/LWR	O	Write strobe (Low)
47	A8	O	Ground		75	MD0	I	Mode select
48	A9	O						
49	A10	O						
50	A11	O	Power supply	76	MD1	I	Analog power supply	
			Reference voltage					
			Analog data input (EQ)					
			Analog input (EQ)					
			Analog data input					
			Analog input (CS)					
			Analog data input (BEND)					
			Analog input (MOD)					
			Analog input (FC)					
			Analog input (BAT)					
			Analog ground					
			Port 8					
			Chip select					
			Ground					
			Port A					

• UPD63200GS-E1 (XP867A00) DAC (Digital to Analog Converter)

DM: IC16

PIN NO.	NAME	I/O	FUNCTION	PIN NO.	NAME	I/O	FUNCTION
1	4/8F	I	4/8 Fs selection	9	R. REF		Channel R voltage reference
2	D. GND		Digital ground	10	L. REF		Channel L voltage reference
3	16 BIT	I	16 bit/18 bit selection	11	L. OUT	O	Channel L output
4	D. VDD		Digital power supply	12	A. GND		Analog ground
5	A. GND		Analog ground	13	WDCK	I	Word clock
6	R. OUT	O	Channel R output	14	RSI	I	Channel R series input
7	A. VDD		Analog power supply	15	SI/LSI	I	Series input/Channel L series input
8	A. VDD			16	CLK	I	Clock

■ IC BLOCK DIAGRAM

- **SN74HC157NSR** (XW110A00)
MM74HC157SJX (XY310A00)
Quad 2 to 1 Multiplexer

DM: IC7

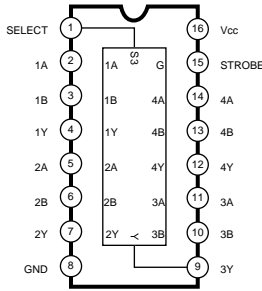

- **MM74HC74ASJX** (XY153A00)
HD744C74FPEL (XL096A00)
TC74HC74AF EL (XW890A00)
Dual D-Type Flip-Flop

DM: IC14
IC25

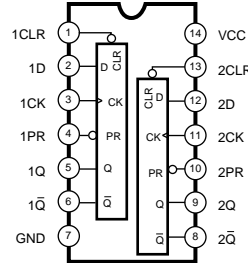

INPUTS				OUTPUTS	
PR	CLR	CLK	D	Q	Q
L	H	X	X	H	L
H	L	X	X	L	H
L	L	X	X	H	H
H	H	f	H	H	L
H	H	f	L	L	H
H	H	L	X	Q _o	Q _o

- **TC74HC245AF** (XS720A00)
HD74HC245FPV (XV611A00)
MM74HC245ASJX (XW107A00)
TC74VHC245FT (XU797A00)
HD74LV245AT (XW744A00)

TRANSCEIVER

DM: IC26
PLG150-AN: IC13
PN: IC3

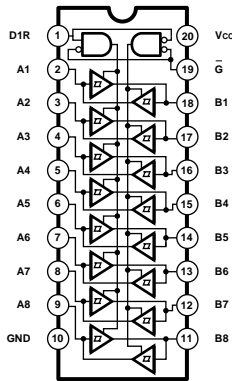

- **HD74HC273FP** (XU533A00)
MM74HC273SJX (XY198A00)
D-FF

PN: IC1,IC2,IC4,IC5,IC6

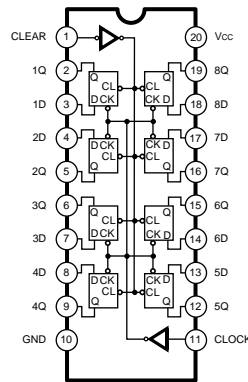

- **HD74HC4051FPEL** (XP373A00)
TC74HC4051AFEL (XY549A00)
Triple 2-Ch. Multiplexer/Demultiplexer

PN: IC7,IC8

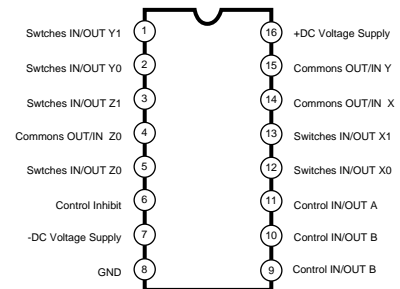

- **TC74VHC153FT** (XV894A00)
Dual 4 to 1 Data Selectors

PLG150-AN: IC8

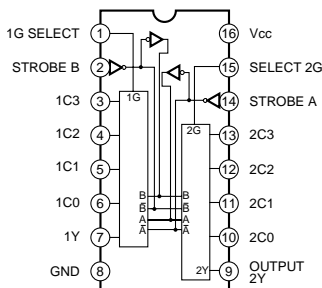

- **TC74VHC139FT** (XV893A00)
Dual 2-to-4 Line Decoder/Demultiplexers

PLG150-AN: IC14

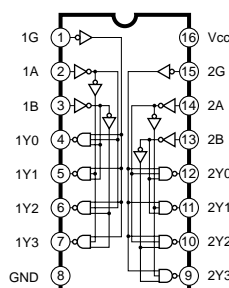

- **NJM4556AMT1** (XQ138A00)
M5216FP-600C (XP263A00)
μPC4570G2 (XF291A00)
Dual Operational Amplifier

DM: IC6,IC18

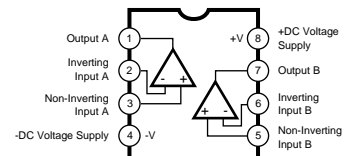

- **NJM4580E-T1** (XQ781A00)
Dual Operational Amplifier

DM: IC11

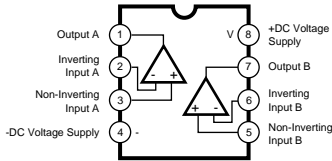

- **NJM3414AM-T1** (XR294A00)
Dual Operational Amplifier

PN: IC9

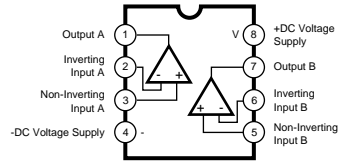

- **TC74HCT04AF-T1** (XI297A00)
Hex Inverter

DM: IC4

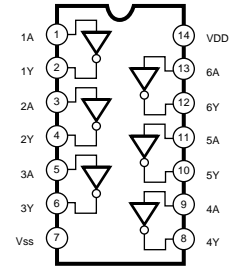

- **MM74HC14JX** (XW104A00)
TC74VHC14FT (XV890A00)
Hex Inverter

DM: IC5
PLG150-AN: IC9

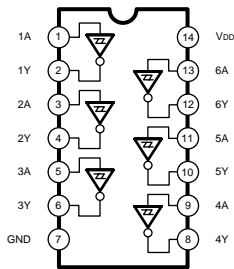

- **TC7S66F** (XR682A00)
Bilateral Switch

DM: IC8

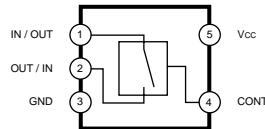

- **TC7W00FU** (XV189A00)
Dual 2-input Nand Gate

DM: IC13

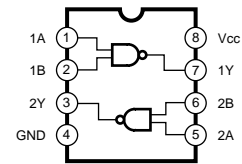

- **TC7W14FU** (XN883A00)
Schmitt Inverter

DM: IC27

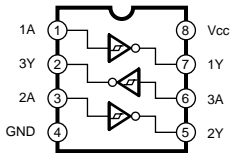

■ DIMENSIONS

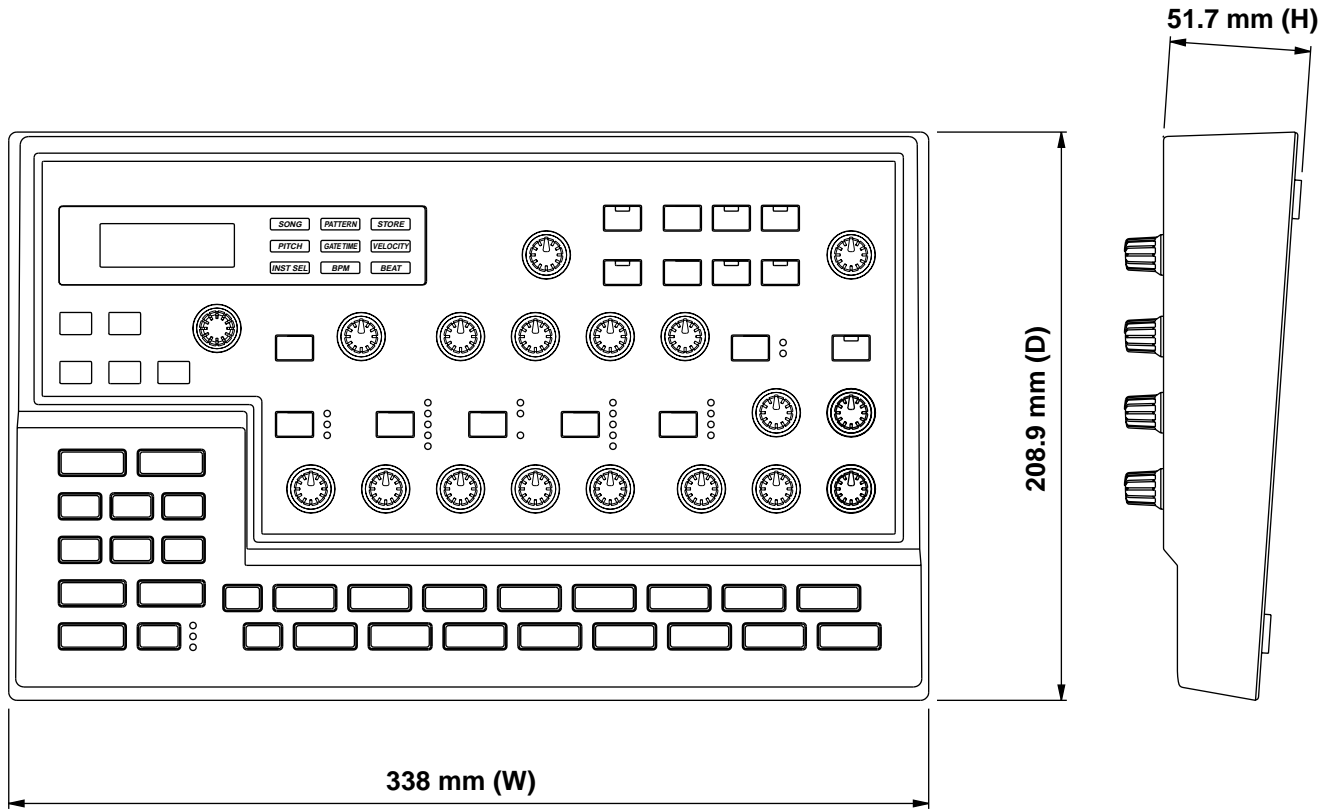

■ CIRCUIT BOARDS

• DM CIRCUIT BOARD

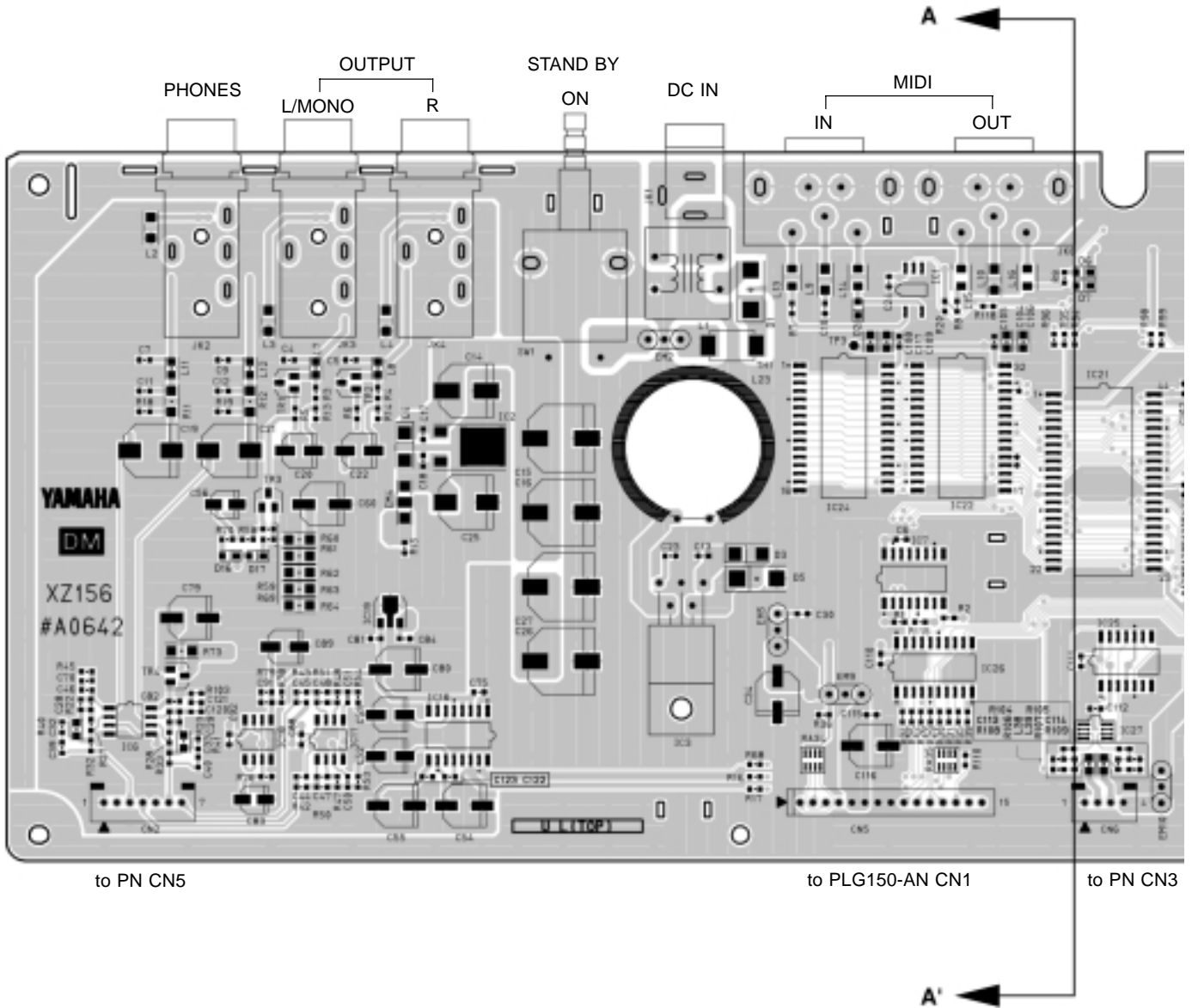

to PN CN5

to PLG150-AN CN1

to PN CN3

Battery VN103500

VN103600 (Battery holder for VN103500)

- Notice for back-up battery removal push the battery as shown in figure, then the battery will pop up.
- Druk de batterij neer beneden zoals aangeven in de tekening, de batterij springt dan neer voren.

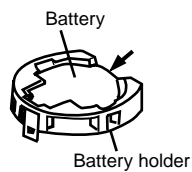

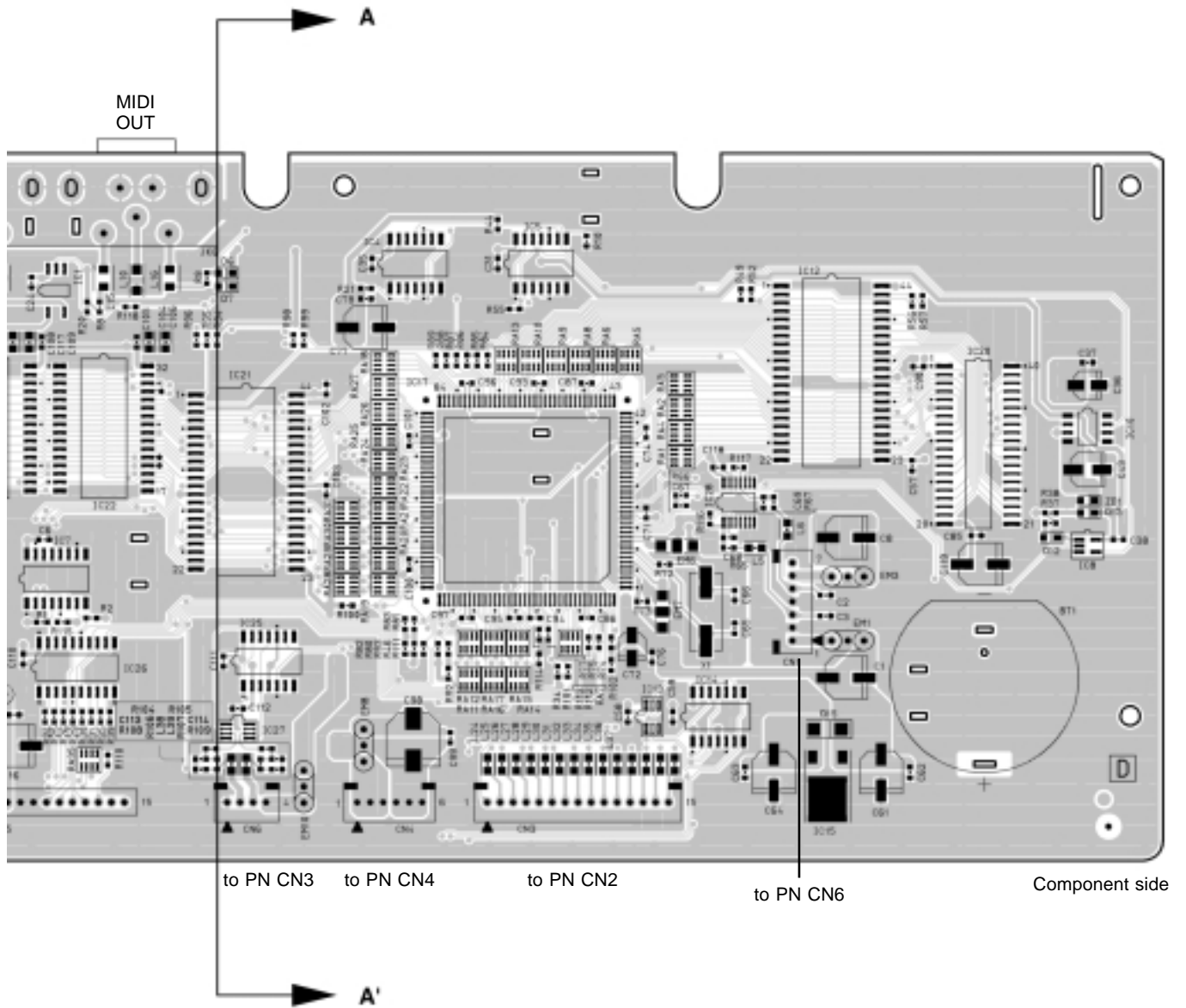



2NA-V625760 

Note: See parts list for details of circuit board component parts.

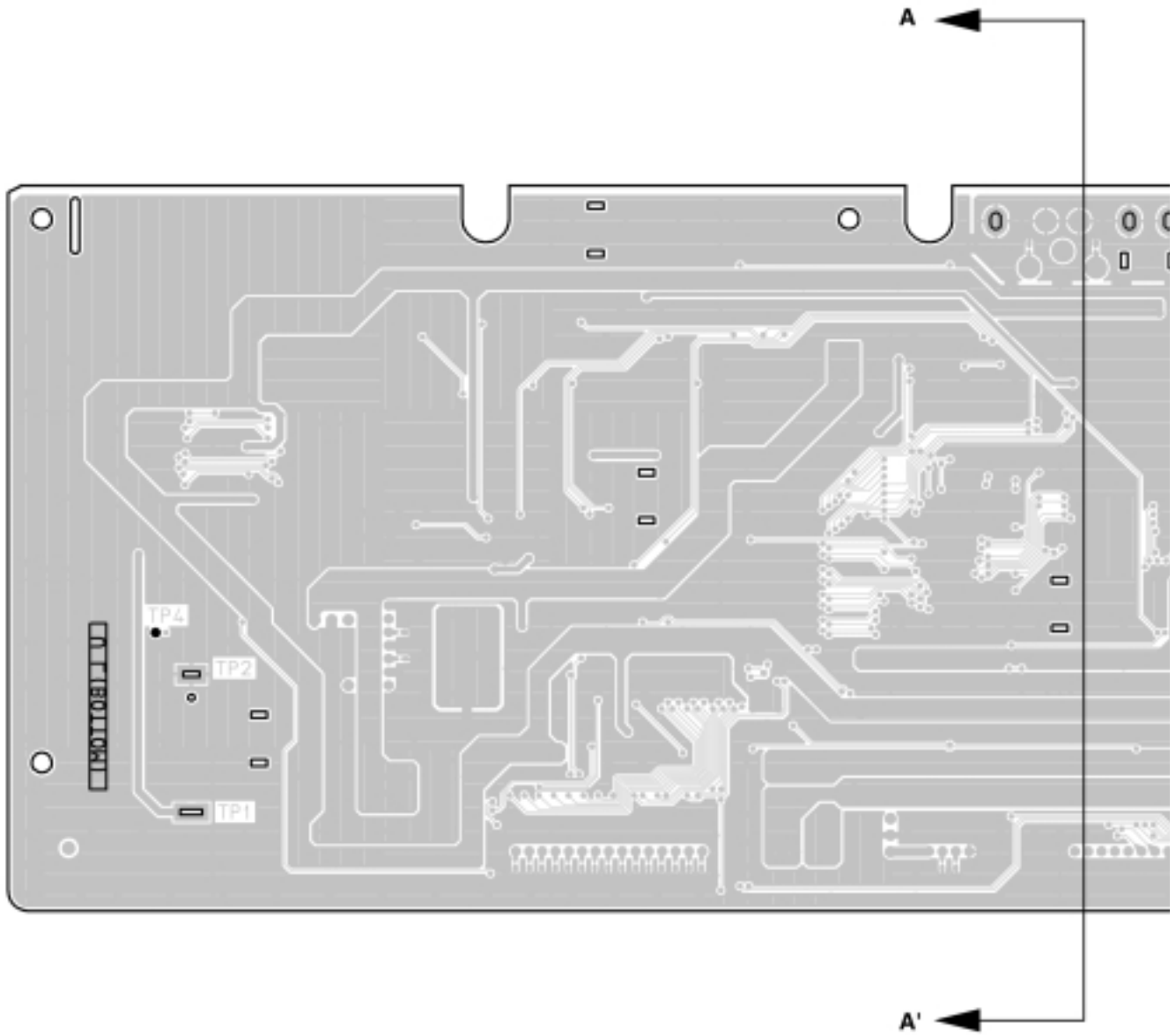
• DM CIRCUIT BOARD

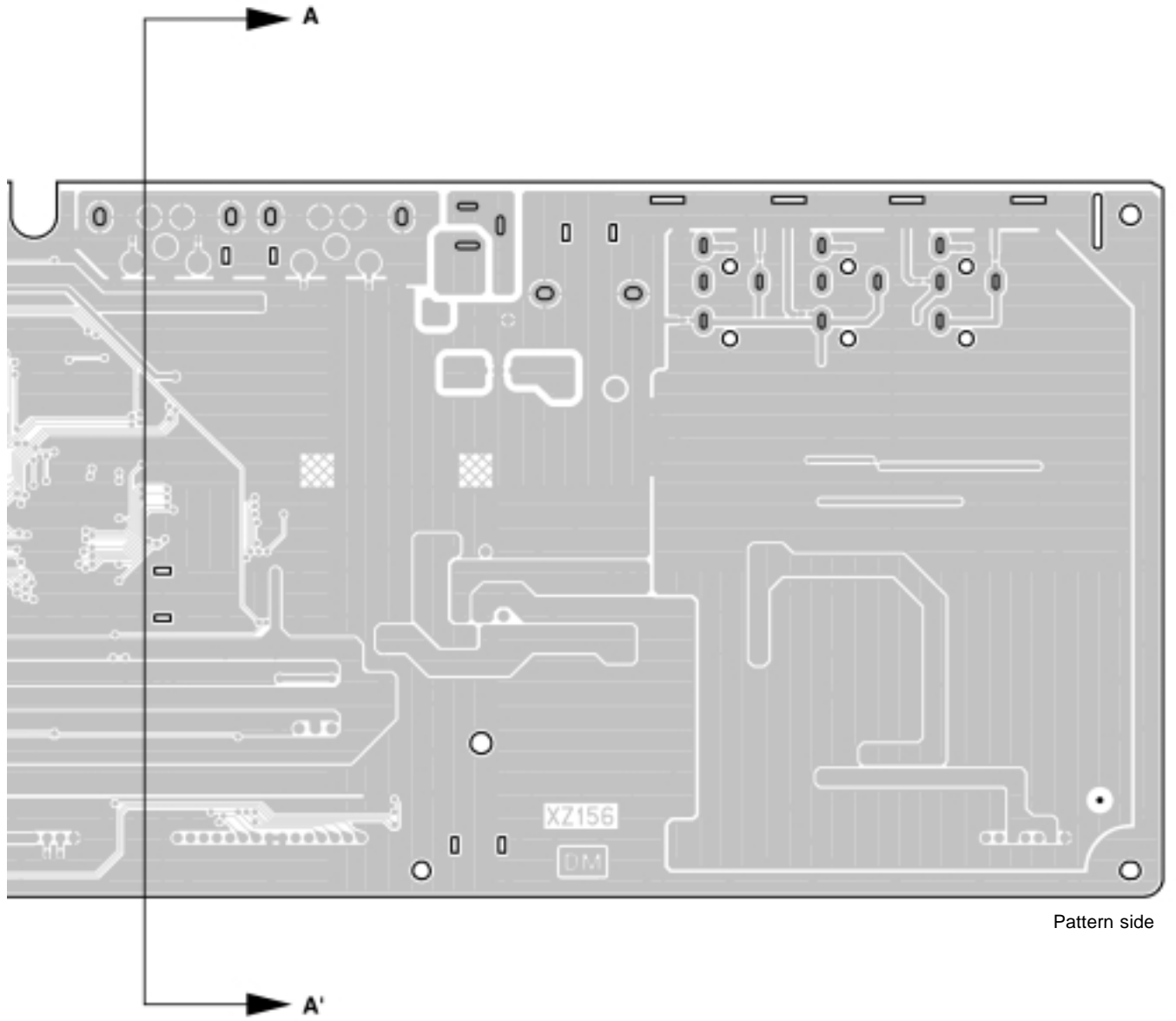



2NA-V625760 

• PN CIRCUIT BOARD

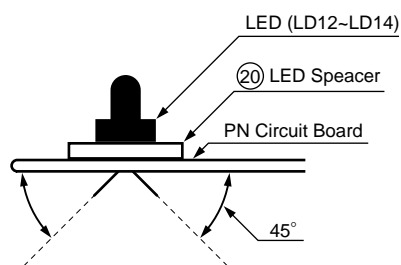
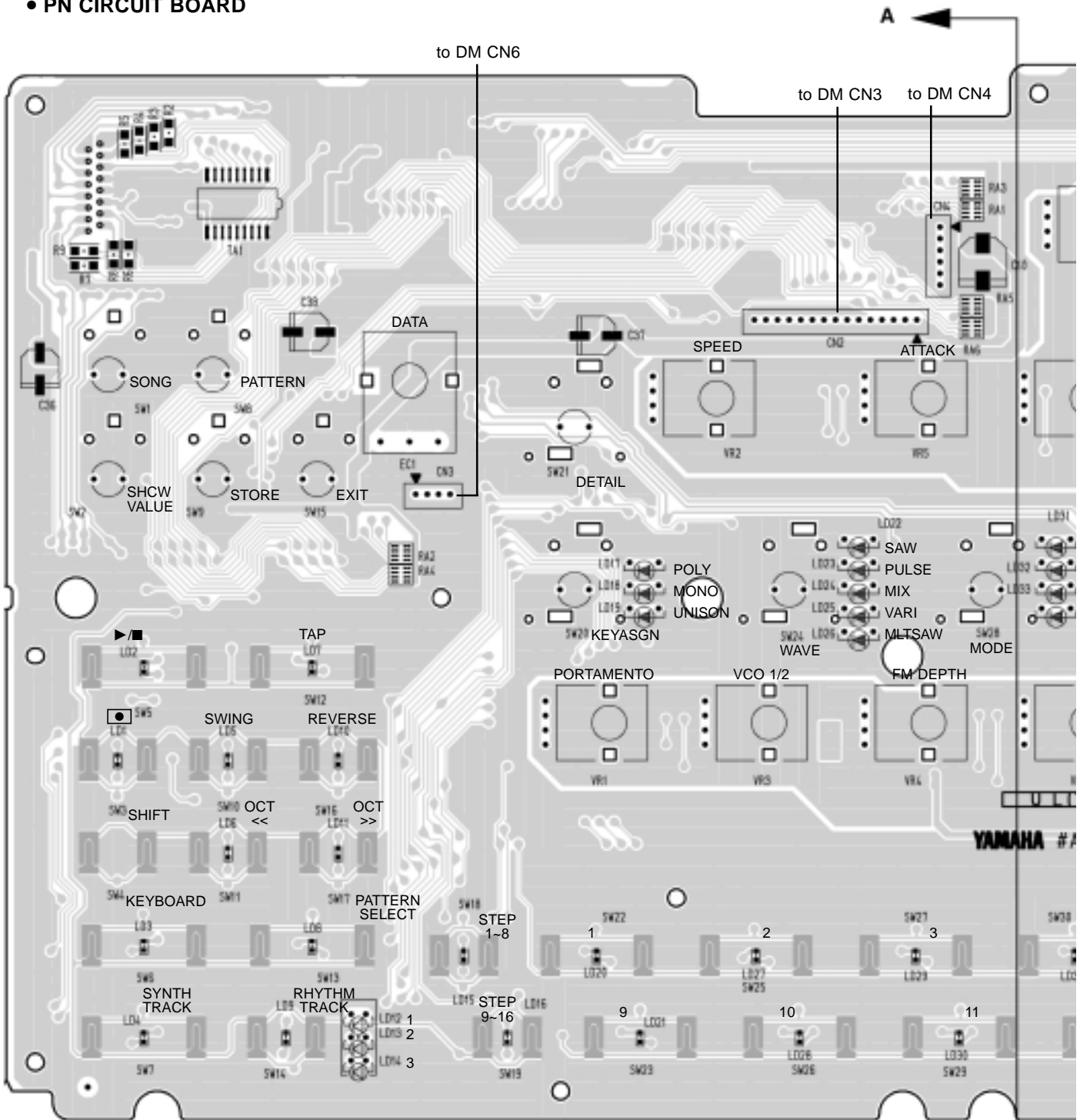

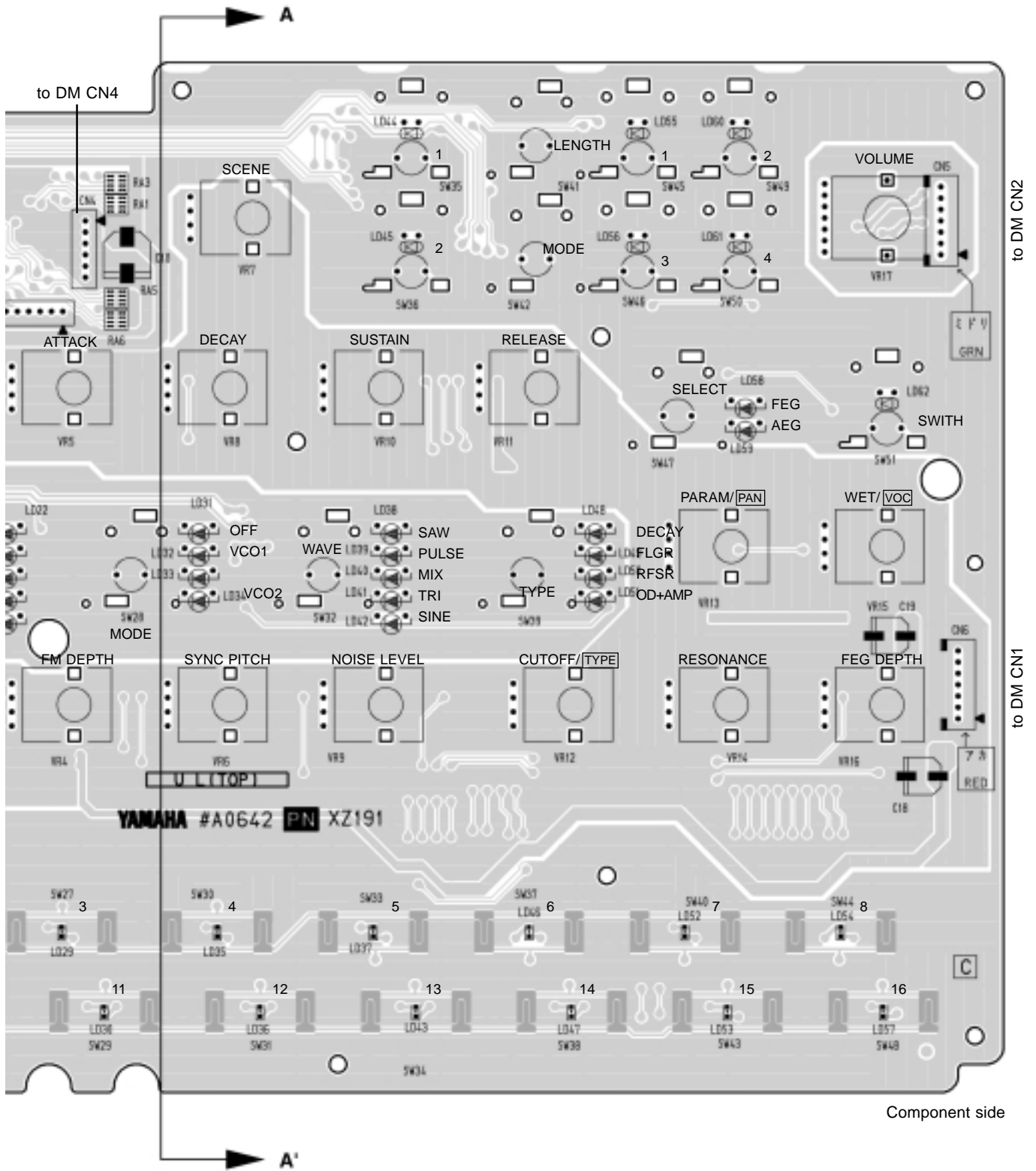

Component side

2NA-V488620

Note: See parts list for details of circuit board component parts.

• PN CIRCUIT BOARD

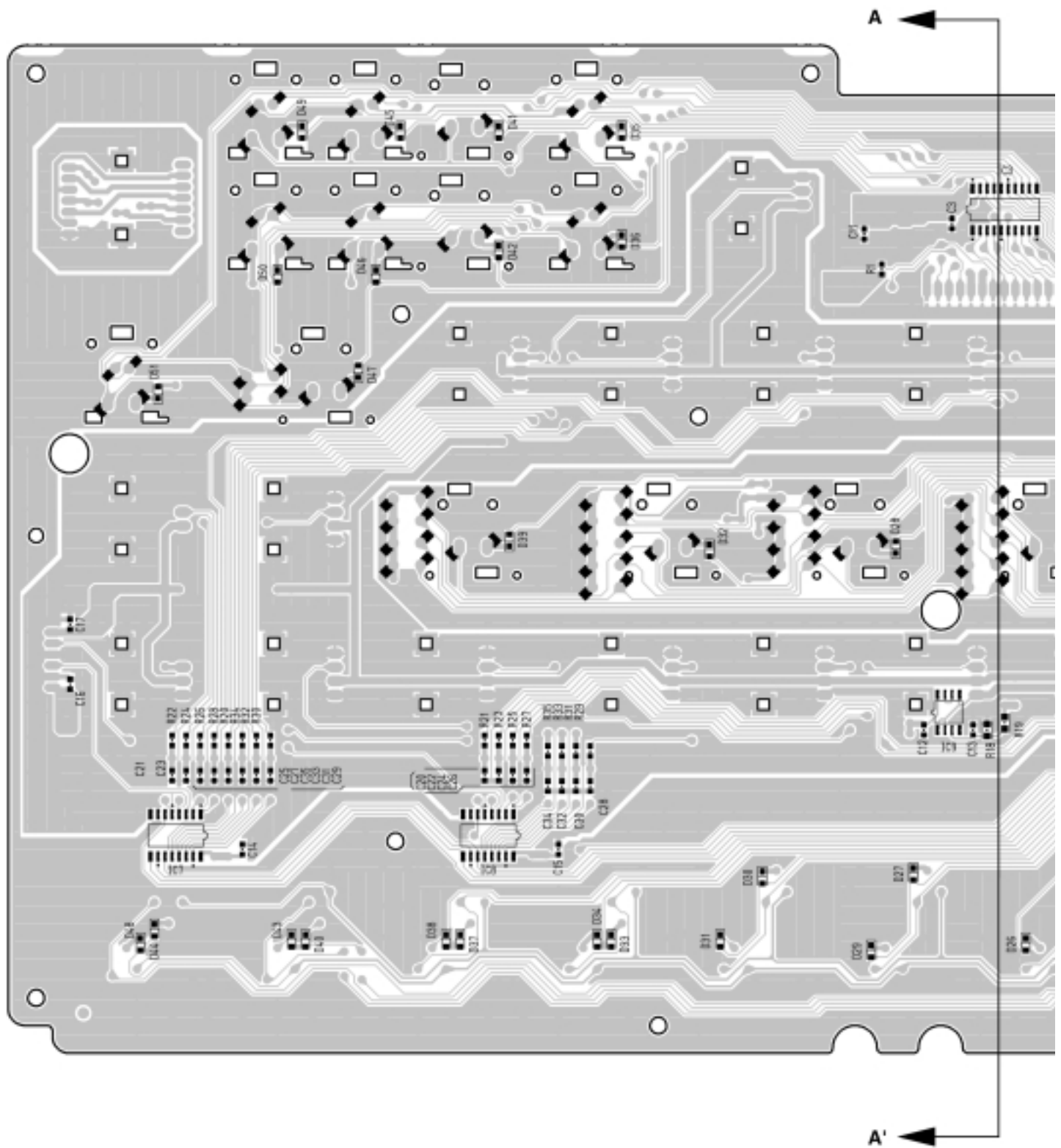

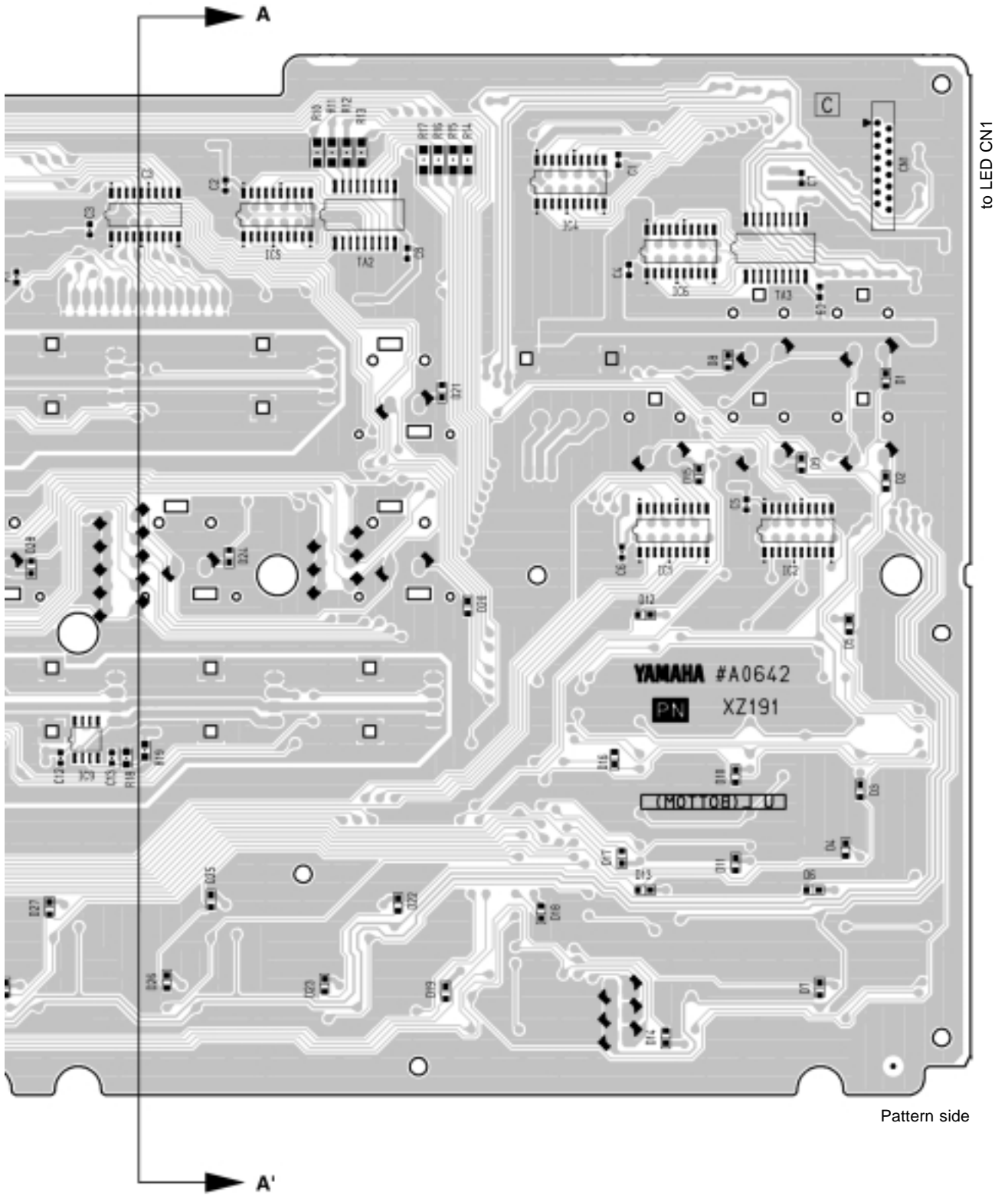

2NA-V488620

Note: See parts list for details of circuit board component parts.

• PLG150-AN Circuit Board

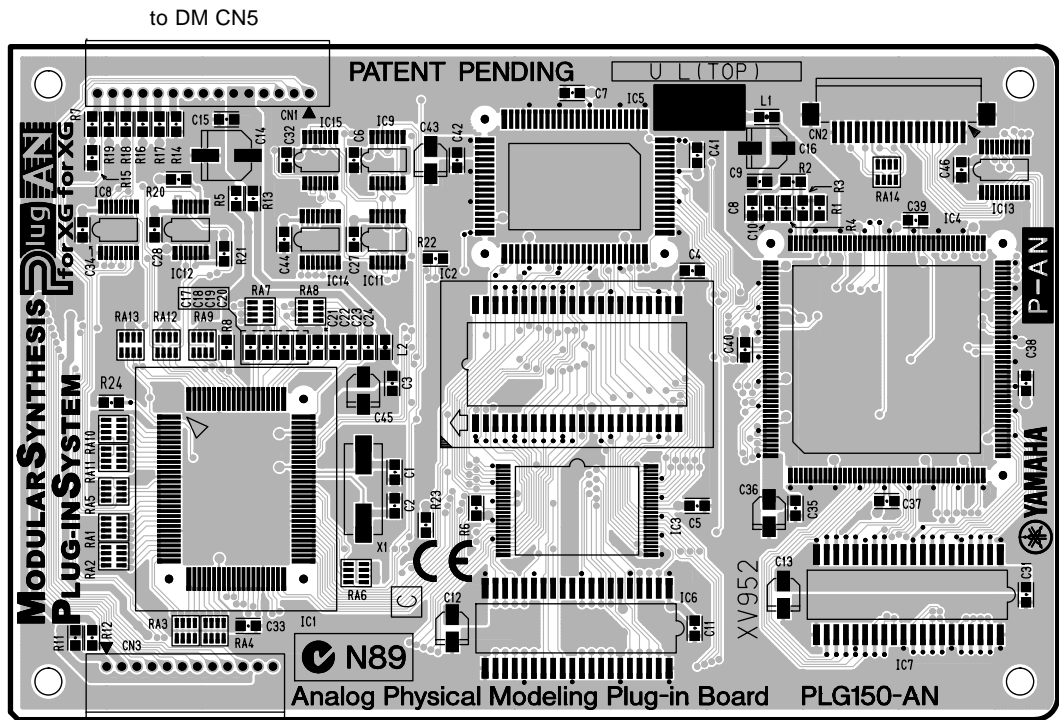

N.C.

Component side

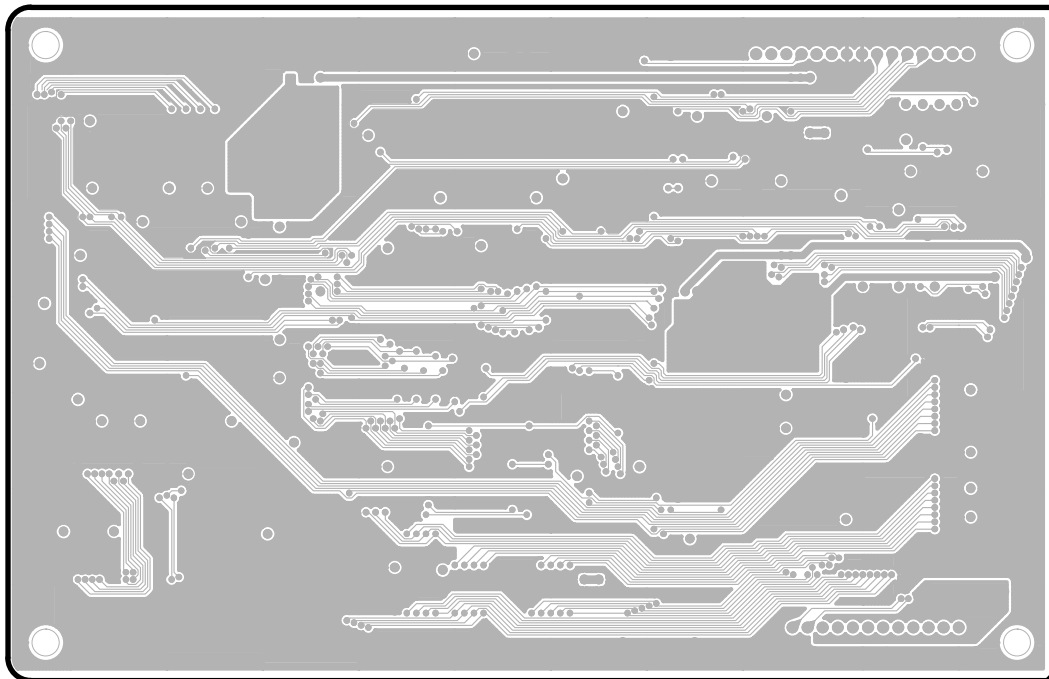

Pattern side

2NA-V414740

Note: See parts list for details of circuit board component parts.

• LED CIRCUIT BOARD

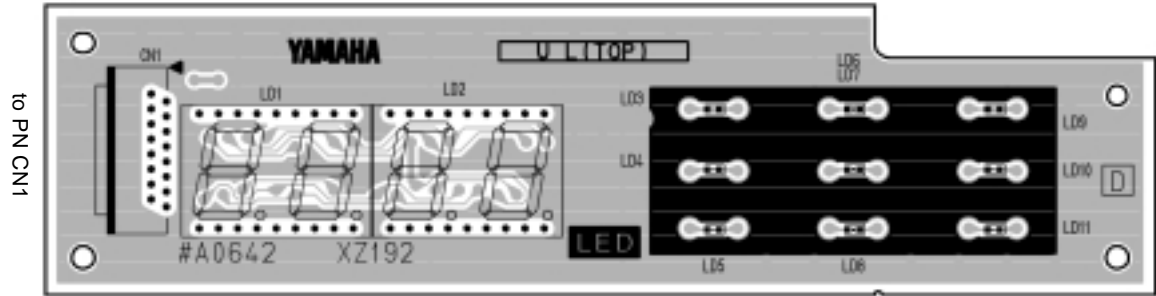

Component side

SONG	PATTERN	STORE
PIT CH	GATE TIME	VELOCITY
INST SEL	BPM	BEAT

2NA-V488650

Note: See parts list for details of circuit board component parts.

■ TEST PROGRAM & INITIALIZE

1. TEST PROGRAM

PREPERATIONS

Following measuring instruments and jigs are required for the test.

Measuring instruments : frequency counter(input impedance: more than 1M Ω)
 oscilloscope(input impedance: more than 1M Ω)
 volt meter(JIS-C curve, input impedance: more than 1M Ω , 0 dBm: 1mW 600 Ω)
 distortion meter(input impedance: more than 1M Ω)
 digital multimeter(input impedance: more than 1M Ω)
 keyboard amplifier(a KS15-equivalence)

Jigs : MIDI cable

Confirm to rotate every control/knob counterclockwise to bottom.

Precautions before starting the test program:

After disassembling/ assembling the unit, confirm that following caution is properly observed before performing any test program.
 After assembling the panel assembly, confirm that the voltage between the measuring points TP1 and TP2 (ground) on the soldered surface of the DM circuit board is from 2.9 V up to 3.4 V (during the power standby mode).

● Start up of the test program

While pressing the [SHOW VALUE], [STORE] and [EXIT] keys, turn on the STANDBY switch.

● Proceeding through the test program

When the test program is started, first "TEST" will appear on the LED display for about one second and then the test program version and the test number will appear consecutively.

Display on the starting up of the test program



Display of the test version



Rotate the [DATA] knob to select the appropriate test program.

Press [STORE] key to perform the test.

When the result is normal (OK), the number of the next test will appear on the LED.

In each test, if "NG" (No Good) error is detected, [Test No. nG] will be displayed on the LED and the program will be put on hold.

Press [EXIT] key to proceed to the next program.

● The test procedure when an error is detected

In each test, if "NG" (No Good) error is detected, press [EXIT] to indicate the LCD display where you can select the next test number.

• The test program

Test No.	Test Item	Test Conditions, Judgment Criteria, etc
C-1	RAM	OK/NG
C-2	RAM BATTERY	OK/NG
C-3	SW & LED	OK/NG LED visually check the lights
C-4	DATA ENTRY	OK/NG (0-23-0)
C-5	KNOB	OK/NG (255,254-127-1, 0)
C-6	MIDI	OK/NG
C-7	WAVE ROM	OK/NG
C-8	1kHz OUTPUT(L) SOUND (SWX00B)	OUTPUT(L) +3.0 +/- 2dBm load 10k Ω OUTPUT(R) less than -80dBm
C-9	1kHz OUTPUT(R) SOUND (SWX00B)	OUTPUT(R) +3.0 +/- 2dBm load 10k Ω OUTPUT(L) less than -80dBm
C-10	PB NAME	OK/NG
C-11	PB RAM	OK/NG
C-12	PB MIDI IN	OK/NG
C-13	PB MEL	OUTPUT(L) -2.0 +/- 2dBm load 10k Ω -5.0 +/- 2dBm load 10k Ω
C-14	Factory set	
C-15	EXIT	Reverberated noise level OUTPUT(L), OUTPUT(R) less than -88 dBm
C-16		OK/NG

• The test program

C-1 CPU RAM

This is the read/ write/ verify check for the MAIN CPU RAM.

Display of Test Results

OK:

NG:

Test End

The test result is displayed and the test will be finished.

Refer to “The test procedure when an error is detected” when “NG” (No Good) error is detected.

C-2 RAM BATTERY

This test checks that the voltage of the RAM backup battery is within the range from 2.9 V up to 3.4 V.

Display of Test Results

OK:

NG:

Test End

The test result is displayed and the test will be finished.

Refer to “The test procedure when an error is detected” when “NG” (No Good) error is detected.

C-3 SW & LED



Press the panel switches according to the order indicated by the LCD and confirm that all switches are working properly. Confirm that the LED corresponding to the panel switch lights on.

After about one second, LED display and all LED's light on for about three seconds and then off to indicate following on the display:



Sine waves sound while the panel switches are being pressed on according to the order indicated by the LED display. When another switch, which is not indicated by the LED display, is pressed, the test stops. The test advances to the next switch test when a correct switch is pressed.

The "OK" will appear when all switches are normal.

The order of the switch check is shown below.

[SONG]>[PATTERN]>[SHOW VALUE]>[STORE]>[EXIT]>[SCENE 1]>[FREE EG LENGTH]>[FREE EG 1]>[FREE EG 2]>[SCENE 2]>[FREE EG MODE]>[FREE EG 3]>[FREE EG 4]>[LFO DETAIL]>[EG SELECT]>[DIST SWITCH]>[COMMON KEY ASGN]>[VCO1 WAVE]>[SYNC MODE]>[VCO2 WAVE]>[EFFECT_TYPE]>[RE-TRIGGER]>[TAP]>[TOP]>[SWING]>[REVERSE]>[SHIFT]>[OCT<<]>[OCT>>]>[KEYBOARD]>[PATTERN SELECT]>[SYNTH TRACK]>[RHYTHM TRACK]>[STEP 1-8]>[1]>[2]>[3]>[4]>[5]>[6]>[7]>[8]>[STEP 9-16]>[9]>[10]>[11]>[12]>[13]>[14]>[15]>[16]

Display of Test Results

OK: 

NG: 

Test End

When all switches are checked normally, the "OK" is displayed and the test will be finished.

C-4 DATA ENTRY

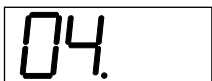

Rotate slowly the knob for DATA ENTRY clockwise until the value 23 appears on the LED display. When 23 appears, a sine wave sounds. After this, rotate slowly the knob counterclockwise to confirm that a sine wave sounds again and the "OK" is displayed on the LED when the value becomes 0 (zero).

Display of Test Results

OK: 

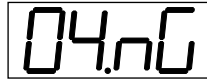
NG: 

Test End

The test result is displayed and the test will be finished.

Refer to "The test procedure when an error is detected" when "NG" (No Good) error is detected.

C-5 KNOB



Rotate slowly the knob indicated by LED display clockwise and then counterclockwise to confirm that the value on the LED increases from 0 to 255 and then decreases from 255 to 0 respectively.

When one knob is confirmed to work properly, a sine wave sounds and the name of the next knob will appear on the LED.

The "OK" will appear when all knobs are normal.

The order of the knob check is shown below.

[SCENE]>[SPEED]>[ATTACK]>[DECAY]>[SUSTAIN]>[RELEASE]>[PARAM]>[WET/VOL]>[PORTAMENTO]>[VCO1/2]>[FM DEPTH]>[SYNC PITCH]>[NOISE LEVEL]>[CUT OFF]>[RESONANCE]>[FEG DEPTH]

Display of Test Results

OK: 

NG: 

Test End

The test result is displayed and the test will be finished.

Refer to "The test procedure when an error is detected" when "NG" (No Good) error is detected.

C-6 MIDI

After connecting the MIDI IN to the MIDI OUT via a MIDI cable, execute the test. MIDI IN transmits the test pattern (AA 50 5F) to be received by MIDI IN.

Display of Test Results

OK: 

NG: 

Test End

The test result is displayed and the test will be finished.

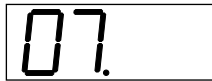
C-7 WAVE ROM

This is the data read/ verify check for the WAVE ROM.

Display of Test Results

OK: 

NG: 

Test End

The test result is displayed and the test will be finished.

Refer to “The test procedure when an error is detected” when “NG” (No Good) error is detected.

C-8 1kHz OUTPUT-L

Insert the appropriate phone plugs into each output jack of the OUTPUT (L, R) and PHONE (L, R), and then connect them to a frequency counter, oscilloscope and AC volt meter.

The VOLUME control must be set at maximum.

Verify that the following signals are output from OUTPUT-L and PHONES-L.

OUTPUT-L: 1kHz +/- 3Hz Asine wave,+3.0 +/- 2dBm (load 10k Ω),Distortion: less than 0.6%

OUTPUT-R: less than -80dBm(load 10k Ω)

PHONES-L: -4.0 +/- 2 dBm (load 33 Ω) ADistortion: less than 0.6%

PHONES-R: less than -60dBm(load 33 Ω)

Display of Test Results

Not appearing

Test End

Rotate [DATA ENTRY] knob clockwise to proceed to the next test.

C-9 1kHz OUTPUT-R

Insert the appropriate phone plugs into each output jack of the OUTPUT (L, R) and PHONE (L, R), and then connect them to a frequency counter, oscilloscope and AC volt meter.

The VOLUME control must be set at maximum.

Verify that the following signals are output from OUTPUT-R and PHONES-R.

OUTPUT-L: less than -80dBm(load 10k Ω)

OUTPUT-R: 1kHz +/- 3Hz Asine wave, +3.0 +/- 2dBm (load 10k Ω), Distortion: less than 0.6%

PHONES-L: less than -60dBm(load 33 Ω)

PHONES-R: -4.0 +/- 2 dBm (load 33 Ω),Distortion: less than 0.6%

Display of Test Results

Not appearing

Test End

Rotate [DATA ENTRY] knob clockwise to proceed to the next test.

C-10 PB NAME

Confirm the proper connection, the name/ version of the plug-in board through transmitting and receiving data between the unit and the plug-in board, which is built in the unit.

Display of Test Results

OK: 

NG: 

Test End

The test result is displayed and the test will be finished.

C-11 PB RAM

Check RAM of the plug-in board which is built in the unit.

Display of Test Results

OK: 

NG: 

Test End

The test result is displayed and the test will be finished.

C-12 PB MIDI IN

Transmit the test pattern from the unit to MIDI IN of the plug-in board, which is built in the unit, and then transmit the test result to the unit. Then confirm the test result.

Display of Test Results

OK: 

NG: 

Test End

The test result is displayed and the test will be finished.

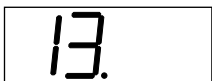
C-13 PB MEL

Check if the power and MEL OUT of the plug-in board are working properly. Confirm that MEL OUT outputs properly to OUTPUT (L, R) of the unit.

Set MEL OUT of the plug-in board in the unit to output properly to OUTPUT (L, R) of the unit. Then insert the appropriate phone plugs into each output jack of the OUTPUT (L, R) and connect them to a frequency counter, oscilloscope and AC volt meter.

The VOLUME control must be set at maximum.

Verify that the following signals are output from OUTPUT-L.

Frequency: 1kHz +/- 3Hz

Level: -2.0dBm +/- 2dBm

Display of Test Results

Not appearing

Test End

Rotate [DATA ENTRY] knob clockwise to proceed to the next test.

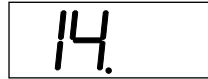
C-14 FACTORY SET

This test is used to initialize the data to the factory settings.

Following operation will execute the test.

Press [STORE] to execute the factory settings.

Press [EXIT] to indicate the LCD display where you can select the next test number.

C-15 EXIT

Following operation ends the test mode and returns to the play mode.

Press [STORE] to end the test mode.

Press [EXIT] to indicate the LCD display where you can select the next test number.

OTHERS

When the unit exits the test mode, it executes a normal start-up sequence same as what it does when the power switch is turned ON.

When the [STANDBY] switch of the unit is turned ON and OFF, confirm that the clicking noises of the OUTPUT (L, R) is less than 0.5 V p-p.

When the unit exits the test mode and returns to the play mode, confirm that the noise levels of each output are as follows. An AC volt meter must be connected for the measurements.

OUTPUT (L,R): less than -88dBm (load 33k Ω)

PHONES (L,R): less than -88dBm (load 33k Ω)

■ ERROR MESSAGES

Display indication	Message	Comment
<i>Err 1</i> (flashes)	Battery Low	This appears when the voltage of the internal backup battery becomes low. Have the battery replaced by your local Yamaha dealer or any Yamaha-authorized service personnel.
<i>Err 2</i> (flashes)	MIDI Buffer Full	This appears when too much MIDI data has been received at one time, causing the unit to stop processing data.
<i>Err 3</i> (flashes)	MIDI Data Error	This appears when the received MIDI data is incorrect or contains errors.
<i>Err 4</i> (flashes)	MIDI Checksum Error	This appears when checksum of the received System Exclusive data is incorrect.

■ MIDI IMPLEMENTATION CHART

YAMAHA [DESKTOP CONTROL SYNTHESIZER]
Model AN200 MIDI Implementation Chart

Date:20-DEC-2000
Version : 1.0

Function...	Transmitted	Recognized	Remarks
Basic Default Channel Changed	1 - 4 1 - 16	1 - 4 1 - 16	
Mode Default Messages Altered	3 x *****	3 3,4 (m=1) *1 x	
Note Number : True voice	1 - 127 *****	0 - 127 0 - 127	
Velocity Note ON Note OFF	o 9nH,v=1-127 o 9nH,v=0	o 9nH,v=1-127 x	
After Key's Touch Ch's	x x	x o	
Pitch Bend	x	o 0-24 semi	
Control Change	0,32 x 1,5,7,10 o 11 x 6,38 o 64,65 x 71-75 o 94 o 98-99 o 16,18,19,80-83 o	o o o o o o o o	Bank Select Data Entry Sound Controller Effect Depth NRPN LSB,MSB Knob Control
Prog Change : True #	o *****	o 0 - 127 0 - 127	
System Exclusive	o	o	
: Song Pos. Common : Song Sel. : Tune	o *3 x x	o *2 x x	
System : Clock Real Time: Commands	o *3 o *3	o *4 o *2	
Aux :All Sound off :Reset All Cntrls :Local ON/OFF :All Notes OFF Mes- :Active Sense sages:Reset	x x x x o x	o(120,126,127) o(121) x o(123-125) o x	
Notes:	*1 m is always treated as "1" regardless of its value. *2 if MIDI control is in or in/out *3 if MIDI control is out or in/out *4 if MIDI sync is external		

Mode 1 : OMNI ON , POLY Mode 2 : OMNI ON , MONO o : Yes
Mode 3 : OMNI OFF, POLY Mode 4 : OMNI OFF, MONO x : No



PARTS LIST

■ **CONTENTS**

OVERALL ASSEMBLY2
 PN ASSEMBLY4
 ELECTRICAL PARTS5

Note) DESTINATION ABBREVIATIONS

A: Australian model	M: South African model
B: British model	O: Chinese model
C: Canadian model	Q: South-east Asia model
D: German model	T: Taiwan model
E: European model	U: U.S.A. model
F: French model	V: General export model (110V)
H: North European model	W: General export model (220V)
I: Indonesian model	N,X: General export model
J: Japanese model	Y: Export model

■ **WARNING**

Components having special characteristics are marked \triangle and must be replaced with parts having specifications equal to those originally installed.

- The numbers in "QTY" shows quantities for each unit.
- The parts with "--" in "Part No." are not available as spare parts.
- The second letter of the shaded () part number is I, not one.
- The second letter of the shaded () part number is O, not zero.

OVERALL ASSEMBLY

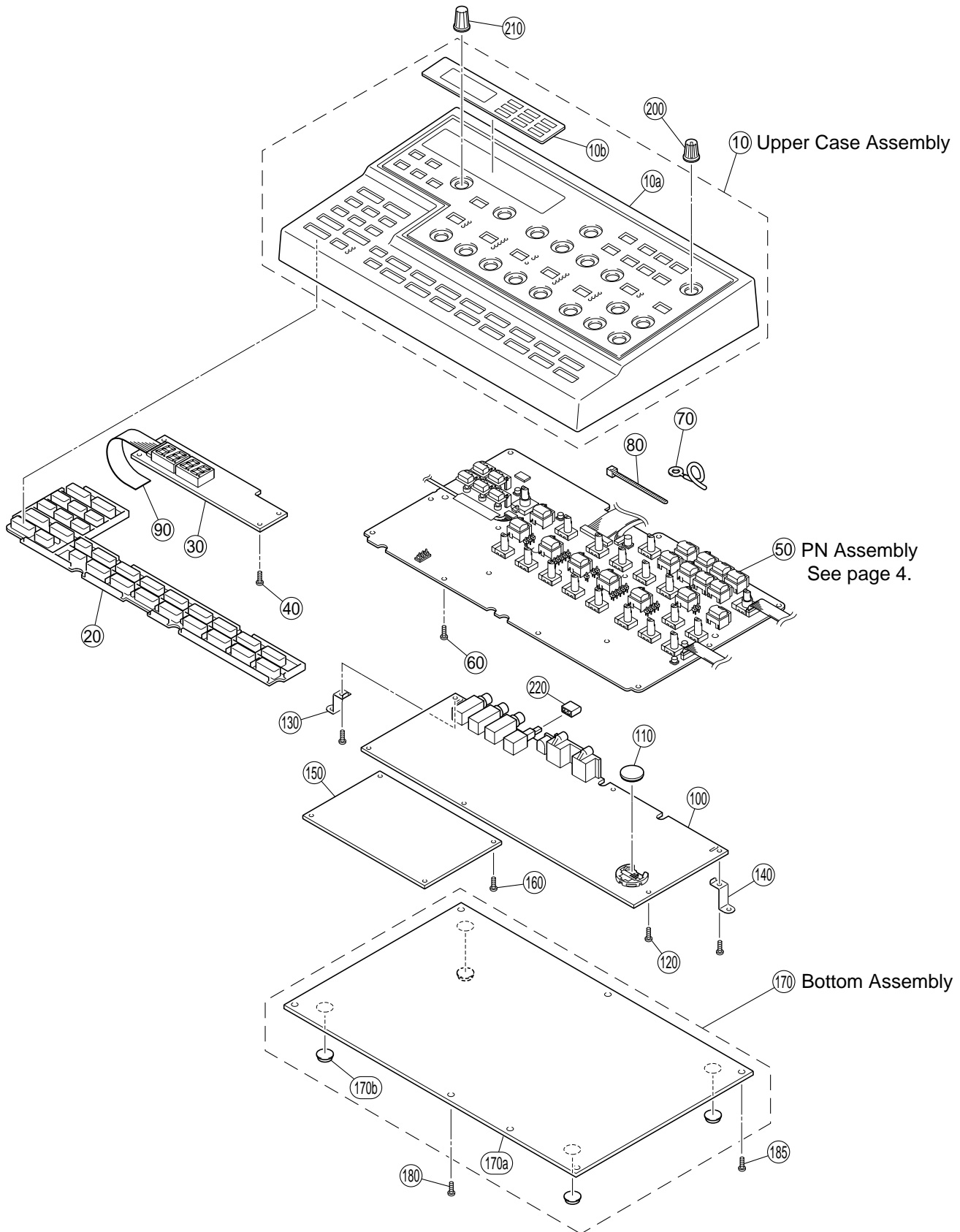

REF NO.	PART NO.	DESCRIPTION		REMARKS	QTY	RANK
* 10	--	Overall Assembly	LM	AN200 JUEW (V678970)		
	V6953100	Upper Case Assembly	DE			
10a	--	Upper Case		(V667890)		
* 10b	V6553600	Protector				
10c	--	Adhesive Tape	#500 8mm	(V754370)		
* 20	V6554200	Rubber Contact		PLAY, TAP, REC, SWING, REVERSE, SHIFT, OCT<<, OCT>>, KEYBOARD, PATTERN SELECT, SYNTH TRACK, RHYTHM TRACK STEP 1-8, STEP 9-16, 1, 2, 3, 4, 5, 6, 7, 8, 9, 10, 11, 12, 13, 14, 15, 16		
* 30	V4886400	Circuit Board	J			
40	EP620100	Bind Head Tapping Screw-P	2.6X8 MFZN2Y		4	01
50	--	PN Assembly	DE	(V679220)		
60	EP620100	Bind Head Tapping Screw-P	2.6X8 MFZN2Y		14	01
70	CB829850	Cord Binder	S-34Z			03
80	CB069250	Cord Holder	BK-1			01
* 90	MFA16080	Connector Assembly	16P 80mm P=1.0			
95	VP834600	Adhesive Tape	12X50		5	
100	V6257600	Circuit Board	J			
* 100a	V7450400	JK Terminal				
* 100b	V7450500	DM Terminal			2	
110	VN103500	Lithium Battery	CR2032			03
120	EP620100	Bind Head Tapping Screw-P	2.6X8 MFZN2Y		6	01
130	--	Angle, L		(V655450)		
140	--	Angle, R		(V655460)		
150	V4147400	Circuit Board	PLG150-AN			31
160	EP600130	Bind Head Tapping Screw-B	3.0X6 MFZN2Y		3	01
170	--	Bottom Assembly	DE	(V679200)		
* 170a	V6792500					
* 170b	V6893600	Foot	3M		4	
180	EP600130	Bind Head Tapping Screw-B	3.0X6 MFZN2Y		5	01
185	EP600130	Bind Head Tapping Screw-B	3.0X6 MFZN2Y		2	01
200	V4765800	Knob	K-CB	SCENE, VOLUME, LFO, ATTACK, DECAY, SUSTAIN, RELEASE, PARAM/PAN, WET/VOL, PORTAMENTO, VCO 1/2, FM DEPTH, SYNC PITCH, NOISE LEVEL, CUTOFF/TYPE, RESONANCE, FEG DEPTH	17	02
210	VU931600	Knob		DATA		03
220	VN129100	Knob, Power Switch	BLACK	STANDBY ON		03
ACCESSORIES						
40	VT368600	AC Adapter	PA-3B JP	AN200 J		09
40	VT368700	AC Adapter	PA-3B UC	U		
40	VT368800	AC Adapter	PA-3B CEE	E		08
60	--	CD-ROM	CDROM 74 12cm	JUEW (XZ637A0)		



*: New Parts

RANK: Japan only

■ PN ASSEMBLY

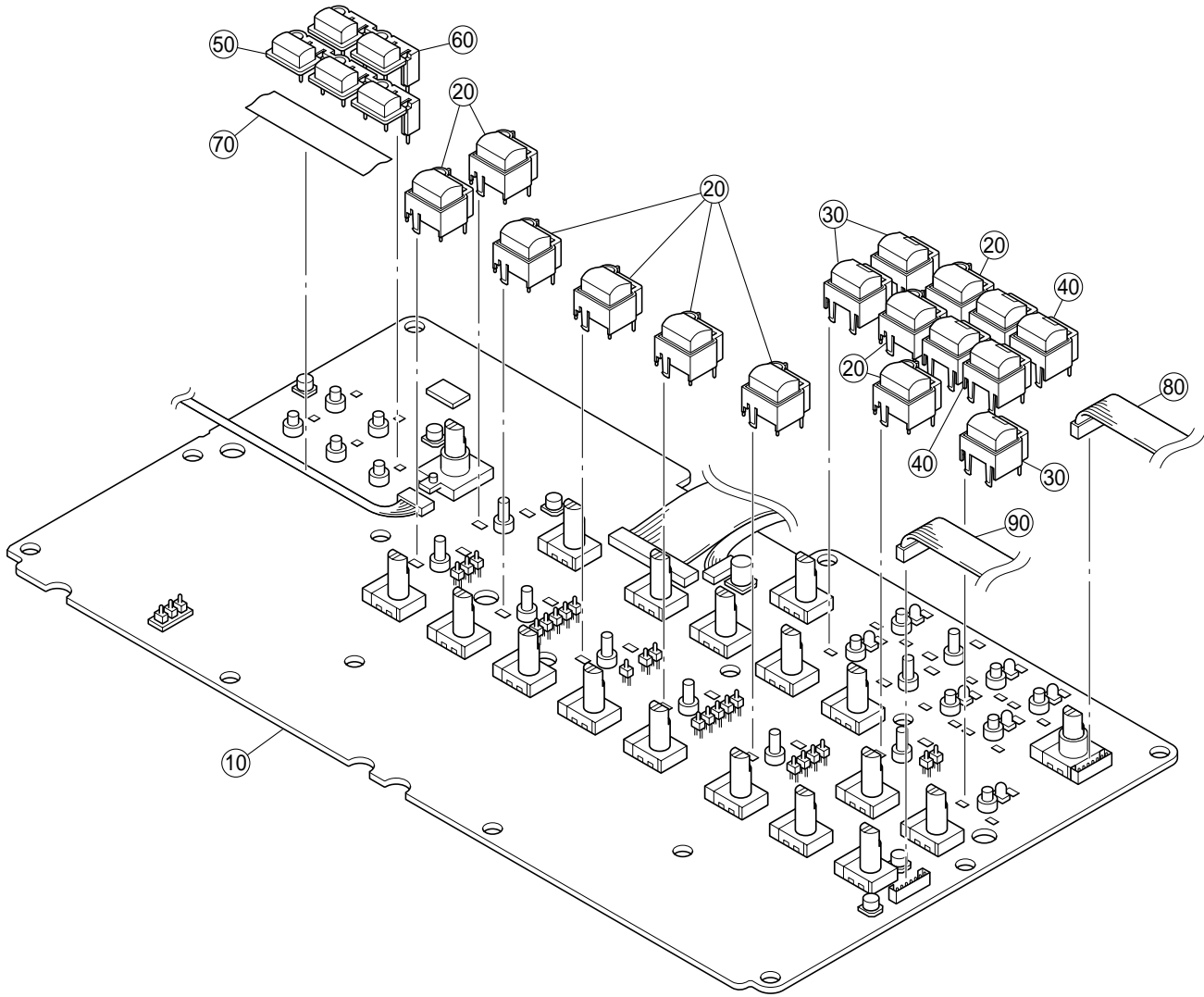

REF NO.	PART NO.	DESCRIPTION		REMARKS	QTY	RANK
		PN ASSEMBLY		AN200		
	--	PN Assembly	DE	(V679220)		
* 10	V4886200	Circuit Board	J			
20	V4162600	Button	M1B	LENGHT, MODE, DETAIL, KEY ASGN, WAVE, MODE, WAVE, TYPE, SELECT	9	01
* 30	V6776500	Button	MR1B	1, 2, SWITCH	3	
* 40	V6776600	Button	MR2B	1, 2, 3, 4	2	
50	V6747300	Button	3B	SHOW VALUE, STORE, EXIT		
60	V6747400	Button	2B	SONG, PATTERN		
70	VP834600	Adhesive Tape	12X50			02
80	--	Connector Assembly	7P(KR-KR)-450L	(V677500)		
90	--	Connector Assembly	7P(KR-KR)-150L	(V677510)		

*: New Parts

RANK: Japan only

■ ELECTRICAL PARTS

REF NO.	PART NO.	DESCRIPTION		REMARKS	QTY	RANK
		ELECTRICAL PARTS		AN200		
*	V6257600	Circuit Board	DM J	(XZ156D0)		
*	V4886400	Circuit Board	LED J	(XZ192D0)		
*	V4886200	Circuit Board	PN J	(XZ191C0)		
	V4147400	Circuit Board	PLG150-AN	(XV952C0)		31
*	V6257600	Circuit Board	DM J	(XZ156D0)		03
BT1	VN103600	Battery Holder	CR2032			01
CN1	VB390300	Connector Base Post	PH- 7P TE			01
CN2	VB390300	Connector Base Post	PH- 7P TE			01
CN3	VF283300	Connector Base Post	PH-15P TE			01
CN4	VB390200	Connector Base Post	PH- 6P TE			
CN5	V6404700	Connector Assembly	15P-50L			01
CN6	VB390000	Connector Base Post	PH- 4P TE			01
C1	UF038100	Electrolytic Cap. (chip)	100 16V			01
C2	US063100	Ceramic Capacitor-B (chip)	1000P 50V K			01
C3	US063100	Ceramic Capacitor-B (chip)	1000P 50V K			01
C4	US063220	Ceramic Capacitor-B (chip)	2200P 50V K			01
C5	US063220	Ceramic Capacitor-B (chip)	2200P 50V K			01
C6	US064100	Ceramic Capacitor-B (chip)	0.0100 50V K			01
C8	UF038100	Electrolytic Cap. (chip)	100 16V			01
C10	US064100	Ceramic Capacitor-B (chip)	0.0100 50V K			01
C11	US063100	Ceramic Capacitor-B (chip)	1000P 50V K			01
C12	US063100	Ceramic Capacitor-B (chip)	1000P 50V K			01
C13	US145100	Ceramic Capacitor-F (chip)	0.1000 25V Z			01
C14	UF148100	Electrolytic Cap. (chip)	100 25V UUR1E1			01
C15	UF148330	Electrolytic Cap. (chip)	330 25V UUR1E3			02
C16	UF148330	Electrolytic Cap. (chip)	330 25V UUR1E3			02
C17	US145100	Ceramic Capacitor-F (chip)	0.1000 25V Z			01
C18	US135100	Ceramic Capacitor-F (chip)	0.1000 16V Z			01
C19	UF138220	Electrolytic Cap. (chip)	220 16V UUR1C2			01
C20	UE237220	Electrolytic Cap. (chip)	22 16V RVO-16			01
C21	UF138220	Electrolytic Cap. (chip)	220 16V UUR1C2			01
C22	UE237220	Electrolytic Cap. (chip)	22 16V RVO-16			01
C23	US064100	Ceramic Capacitor-B (chip)	0.0100 50V K			01
C24	US135100	Ceramic Capacitor-F (chip)	0.1000 16V Z			01
C25	UE238220	Electrolytic Cap. (chip)	220 16V RVO-16			01
C26	UF148330	Electrolytic Cap. (chip)	330 25V UUR1E3			02
C27	UF148330	Electrolytic Cap. (chip)	330 25V UUR1E3			02
C28	US062100	Ceramic Capacitor-SL(chip)	100P 50V J			01
C29	US062100	Ceramic Capacitor-SL(chip)	100P 50V J			01
C30	US135100	Ceramic Capacitor-F (chip)	0.1000 16V Z			01
C31	US064100	Ceramic Capacitor-B (chip)	0.0100 50V K			01
C34	UF038100	Electrolytic Cap. (chip)	100 16V			01
C35	US064100	Ceramic Capacitor-B (chip)	0.0100 50V K			01
C36	UF037100	Electrolytic Cap. (chip)	10 16V			01
C37	US064100	Ceramic Capacitor-B (chip)	0.0100 50V K			01
C38	US064100	Ceramic Capacitor-B (chip)	0.0100 50V K			01
C43	UF066470	Electrolytic Cap. (chip)	4.7 50V			01
C44	US063470	Ceramic Capacitor-B (chip)	4700P 50V K			01
C45	US063470	Ceramic Capacitor-B (chip)	4700P 50V K			01
C46	US063220	Ceramic Capacitor-B (chip)	2200P 50V K			01
C47	US062270	Ceramic Capacitor-SL(chip)	270P 50V J			01
C48	US062270	Ceramic Capacitor-SL(chip)	270P 50V J			01
C50	US063220	Ceramic Capacitor-B (chip)	2200P 50V K			01
C51	US063220	Ceramic Capacitor-B (chip)	2200P 50V K			01
C52	UE237220	Electrolytic Cap. (chip)	22 16V RVO-16			01
C53	UE237220	Electrolytic Cap. (chip)	22 16V RVO-16			01
C54	UF037470	Electrolytic Cap. (chip)	47 16V			01
C55	UF037470	Electrolytic Cap. (chip)	47 16V			01
C56	UF037100	Electrolytic Cap. (chip)	10 16V			01
C57	US135100	Ceramic Capacitor-F (chip)	0.1000 16V Z			01
C58	US064100	Ceramic Capacitor-B (chip)	0.0100 50V K			01
C59	US064100	Ceramic Capacitor-B (chip)	0.0100 50V K			01
C60	UF038100	Electrolytic Cap. (chip)	100 16V			01
C61	UF038100	Electrolytic Cap. (chip)	100 16V			01
C62	US135100	Ceramic Capacitor-F (chip)	0.1000 16V Z			01
C63	US135100	Ceramic Capacitor-F (chip)	0.1000 16V Z			01
C64	UF038100	Electrolytic Cap. (chip)	100 16V			01
C65	US061220	Ceramic Capacitor-CH(chip)	22P 50V J			01

*: New Parts

RANK: Japan only

REF NO.	PART NO.	DESCRIPTION		REMARKS	QTY	RANK
C66	US061270	Ceramic Capacitor-CH(chip)	27P 50V J			01
C67	US063100	Ceramic Capacitor-B (chip)	1000P 50V K			01
C70	US063220	Ceramic Capacitor-B (chip)	2200P 50V K			01
C71	US135100	Ceramic Capacitor-F (chip)	0.1000 16V Z			01
C72	UF037100	Electrolytic Cap. (chip)	10 16V			01
C73	US135100	Ceramic Capacitor-F (chip)	0.1000 16V Z			01
C74	US064100	Ceramic Capacitor-B (chip)	0.0100 50V K			01
C75	US135100	Ceramic Capacitor-F (chip)	0.1000 16V Z			01
C76	US064100	Ceramic Capacitor-B (chip)	0.0100 50V K			01
C77	UF038100	Electrolytic Cap. (chip)	100 16V			01
C78	US064100	Ceramic Capacitor-B (chip)	0.0100 50V K			01
C79	UF038100	Electrolytic Cap. (chip)	100 16V			01
C80	UF037470	Electrolytic Cap. (chip)	47 16V			01
C81	US135100	Ceramic Capacitor-F (chip)	0.1000 16V Z			01
C82	US135100	Ceramic Capacitor-F (chip)	0.1000 16V Z			01
C83	UF037100	Electrolytic Cap. (chip)	10 16V			01
C84	US135100	Ceramic Capacitor-F (chip)	0.1000 16V Z			01
C85	US064100	Ceramic Capacitor-B (chip)	0.0100 50V K			01
C86	US064100	Ceramic Capacitor-B (chip)	0.0100 50V K			01
C87	US064100	Ceramic Capacitor-B (chip)	0.0100 50V K			01
C88	US135100	Ceramic Capacitor-F (chip)	0.1000 16V Z			01
C89	UF037220	Electrolytic Cap. (chip)	22 16V			01
C90	US135100	Ceramic Capacitor-F (chip)	0.1000 16V Z			01
C91	US135100	Ceramic Capacitor-F (chip)	0.1000 16V Z			01
C92	US135100	Ceramic Capacitor-F (chip)	0.1000 16V Z			01
C93	US064100	Ceramic Capacitor-B (chip)	0.0100 50V K			01
C94	US064100	Ceramic Capacitor-B (chip)	0.0100 50V K			01
C95	US064100	Ceramic Capacitor-B (chip)	0.0100 50V K			01
C96	US064100	Ceramic Capacitor-B (chip)	0.0100 50V K			01
C97	US064100	Ceramic Capacitor-B (chip)	0.0100 50V K			01
C98	UF138220	Electrolytic Cap. (chip)	220 16V UUR1C2			01
C99	US064100	Ceramic Capacitor-B (chip)	0.0100 50V K			01
C100	US064100	Ceramic Capacitor-B (chip)	0.0100 50V K			01
C101	US064100	Ceramic Capacitor-B (chip)	0.0100 50V K			01
C102	US064100	Ceramic Capacitor-B (chip)	0.0100 50V K			01
C103	US135100	Ceramic Capacitor-F (chip)	0.1000 16V Z			01
C104	UB446100	Ceramic Capacitor-F (chip)	F 1.0 16V Z			01
C105	US064100	Ceramic Capacitor-B (chip)	0.0100 50V K			01
C106	UB446100	Ceramic Capacitor-F (chip)	F 1.0 16V Z			01
C108	UB446100	Ceramic Capacitor-F (chip)	F 1.0 16V Z			01
C109	US064100	Ceramic Capacitor-B (chip)	0.0100 50V K			01
C110	US064100	Ceramic Capacitor-B (chip)	0.0100 50V K			01
C111	US064100	Ceramic Capacitor-B (chip)	0.0100 50V K			01
C112	US064100	Ceramic Capacitor-B (chip)	0.0100 50V K			01
C113	US064100	Ceramic Capacitor-B (chip)	0.0100 50V K			01
C114	US064100	Ceramic Capacitor-B (chip)	0.0100 50V K			01
C115	US064100	Ceramic Capacitor-B (chip)	0.0100 50V K			01
C116	UF038100	Electrolytic Cap. (chip)	100 16V			01
C117	UB446100	Ceramic Capacitor-F (chip)	F 1.0 16V Z			01
C118	US064100	Ceramic Capacitor-B (chip)	0.0100 50V K			01
C119	UF037470	Electrolytic Cap. (chip)	47 16V			01
C120	US063220	Ceramic Capacitor-B (chip)	2200P 50V K			01
C121	US063220	Ceramic Capacitor-B (chip)	2200P 50V K			01
C122	US135100	Ceramic Capacitor-F (chip)	0.1000 16V Z			01
C123	US135100	Ceramic Capacitor-F (chip)	0.1000 16V Z			01
D1	VZ016600	Diode	D3FP3			03
D2	VT332900	Diode	1SS355 TE-17			01
D3	VS201100	Diode	D1F60			01
D4	VS201100	Diode	D1F60			01
D5	VZ016600	Diode	D3FP3			03
D6	VT332900	Diode	1SS355 TE-17			01
D7	VT332900	Diode	1SS355 TE-17			01
D12	VT332900	Diode	1SS355 TE-17			01
D13	VT332900	Diode	1SS355 TE-17			01
D15	VS201100	Diode	D1F60			01
D16	VT332900	Diode	1SS355 TE-17			01
D17	VT332900	Diode	1SS355 TE-17			01
EM1	VR193800	LC Filter	STF-104ZB-TBM			01
EM2	VR193800	LC Filter	STF-104ZB-TBM			01
EM3	VR193800	LC Filter	STF-104ZB-TBM			01

*: New Parts

RANK: Japan only

REF NO.	PART NO.	DESCRIPTION		REMARKS	QTY	RANK
EM4	V6196600	EMI Filter (chip)	NFM4516P13C204FT1			01
EM5	VR193800	LC Filter	STF-104ZB-TBM			01
EM6	V6196600	EMI Filter (chip)	NFM4516P13C204FT1			01
EM7	V6196600	EMI Filter (chip)	NFM4516P13C204FT1			01
EM8	VR193800	LC Filter	STF-104ZB-TBM			01
EM9	VR193800	LC Filter	STF-104ZB-TBM			01
EM10	VR193800	LC Filter	STF-104ZB-TBM			01
IC1	VN686000	Photo Coupler	PC410T			04
IC1	VR903700	Photo Coupler	HCPL-M600			04
IC2	XT441A00	IC	UPC2909T-E1	REGULATOR +9V		03
IC3	XT514A00	IC	SI-8050S(LF1103)	REGULATOR +5V		05
IC4	XI297A00	IC	TC74HCT04AF-T1	INVERTER		01
IC5	XW104A00	IC	MM74HC14SJX	INVERTER		01
IC6	XP263A00	IC	M5216FP-600C	OP AMP		03
IC6	XQ138A00	IC	NJM4556AMT1	OP AMP		03
IC7	XW110A00	IC	SN74HC157NSR	MULTIPLEXER		02
IC7	XY310A00	IC	MM74HC157SJX	MULTIPLEXER		01
IC8	XR682A00	IC	TC7S66F	BILATERAL SWITCH		01
IC10	XI686A00	IC	M62021FP	SYSTEM RESET		04
* IC11	XQ781A00	IC	NJM4580E-T1	OP AMP		03
* IC12	XZ582100	IC	K3N4C1000D-GC	(WAVE)		
* IC13	XV189A00	IC	TC7W00FU	NAND		
IC14	XL096A00	IC	HD74HC74FPEL	D-FF		01
IC14	XW890A00	IC	TC74HC74AF(EL)	D-FF		01
IC14	XY153A00	IC	MM74HC74ASJX	D-FF		01
IC15	XS516A00	IC	UPC2933T-E1	REGULATOR +3.3V		03
IC16	XP867A00	IC	UPD63200GS-E1	DAC		07
IC17	XU947C00	IC	HG73C205AFD	SWX00B		09
IC18	XF291A00	IC	UPC4570G2	OP AMP		03
IC19	XJ598A00	IC	NJM78L05UA	REGULATOR +5V		02
IC20	XV077A00	IC	MSM514260C-60JS	DRAM 4M		07
* IC20	XV839A00	IC	SDM4260CLU-6S	DRAM 4M		08
IC21	XZ580D00	IC	642SV030	FRASH ROM		
IC22	XT138A00	IC	UPD431000AGW-70LL	SRAM		07
IC22	XV976A00	IC	M5M51008CFP-70H	SRAM		07
IC24	XT138A00	IC	UPD431000AGW-70LL	SRAM		07
IC24	XV976A00	IC	M5M51008CFP-70H	SRAM		07
IC25	XL096A00	IC	HD74HC74FPEL	D-FF		01
IC25	XW890A00	IC	TC74HC74AF(EL)	D-FF		01
IC25	XY153A00	IC	MM74HC74ASJX	D-FF		01
IC26	XS720A00	IC	TC74HC245AF	TRANSCEIVER		03
IC26	XV611A00	IC	HD74HC245FPV	TRANSCEIVER		03
IC26	XW107A00	IC	MM74HC245ASJX	TRANSCEIVER		03
IC27	XN883A00	IC	TC7W14FU	INVERTER		02
JK1	LB302260	Connector	HEC0470-01-630	DC IN		02
JK2	VS115400	Phone Jack	LGR4609-7000	PHONES		01
JK3	VS115400	Phone Jack	LGR4609-7000	OUTPUT L/MONO		01
JK4	VS115400	Phone Jack	LGR4609-7000	OUTPUT R		01
JK6	VK519000	DIN Connector	5P3 YKF51-50	MIDI IN, MIDI OUT		04
L1	VH746100	Coil	PLT09H-2003R			04
L2	VL139800	Chip Solid Inductance	BLM31A700SPT 70ohm			01
L3	VL139800	Chip Solid Inductance	BLM31A700SPT 70ohm			01
L4	VL139800	Chip Solid Inductance	BLM31A700SPT 70ohm			01
L5	VR579900	Chip Inductance	BK2125HS601-T			01
L6	VR579900	Chip Inductance	BK2125HS601-T			01
L7	VR579900	Chip Inductance	BK2125HS601-T			01
L8	VR579900	Chip Inductance	BK2125HS601-T			01
L9	VL139800	Chip Solid Inductance	BLM31A700SPT 70ohm			01
L10	VL139800	Chip Solid Inductance	BLM31A700SPT 70ohm			01
L11	VR579900	Chip Inductance	BK2125HS601-T			01
L12	VR579900	Chip Inductance	BK2125HS601-T			01
L13	VR243700	Chip Inductance	56U LEM2520 T 560J			01
L14	VR243700	Chip Inductance	56U LEM2520 T 560J			01
L15	VR243700	Chip Inductance	56U LEM2520 T 560J			01
L16	VR243700	Chip Inductance	56U LEM2520 T 560J			01
L23	V4678200	Coil	HP-022Z			05
L24	VR579900	Chip Inductance	BK2125HS601-T			01
L25	VR579900	Chip Inductance	BK2125HS601-T			01
L26	VR579900	Chip Inductance	BK2125HS601-T			01
L27	VR579900	Chip Inductance	BK2125HS601-T			01

*: New Parts

RANK: Japan only

REF NO.	PART NO.	DESCRIPTION	REMARKS	QTY	RANK
L28	VR579900	Chip Inductance	BK2125HS601-T		01
L29	VR579900	Chip Inductance	BK2125HS601-T		01
L30	VR579900	Chip Inductance	BK2125HS601-T		01
L31	VR579900	Chip Inductance	BK2125HS601-T		01
L32	VR579900	Chip Inductance	BK2125HS601-T		01
L33	VR579900	Chip Inductance	BK2125HS601-T		01
L34	VR579900	Chip Inductance	BK2125HS601-T		01
L35	VR579900	Chip Inductance	BK2125HS601-T		01
L36	VR579900	Chip Inductance	BK2125HS601-T		01
L37	VR579900	Chip Inductance	BK2125HS601-T		01
L38	VR579900	Chip Inductance	BK2125HS601-T		01
L39	VR579900	Chip Inductance	BK2125HS601-T		01
RA1	RE044680	Resistor Array	68X4		01
RA2	RE044680	Resistor Array	68X4		01
RA3	RE044680	Resistor Array	68X4		01
RA4	RE044680	Resistor Array	68X4		01
RA5	RE044680	Resistor Array	68X4		01
RA6	RE044680	Resistor Array	68X4		01
RA7	RE044680	Resistor Array	68X4		01
RA8	RE044680	Resistor Array	68X4		01
RA9	RE044680	Resistor Array	68X4		01
RA10	RE044680	Resistor Array	68X4		01
RA11	RE047220	Resistor Array	22KX4		01
RA12	RE044680	Resistor Array	68X4		01
RA13	RE044680	Resistor Array	68X4		01
RA14	RE047220	Resistor Array	22KX4		01
RA15	RE044680	Resistor Array	68X4		01
RA16	RE047220	Resistor Array	22KX4		01
RA17	RE044680	Resistor Array	68X4		01
RA18	RE044680	Resistor Array	68X4		01
RA19	RE044680	Resistor Array	68X4		01
RA20	RE044680	Resistor Array	68X4		01
RA21	RE044680	Resistor Array	68X4		01
RA22	RE044680	Resistor Array	68X4		01
RA23	RE044680	Resistor Array	68X4		01
RA24	RE044680	Resistor Array	68X4		01
RA25	RE044680	Resistor Array	68X4		01
RA26	RE044680	Resistor Array	68X4		01
RA27	RE044680	Resistor Array	68X4		01
RA28	RE047220	Resistor Array	22KX4		01
RA29	RE047220	Resistor Array	22KX4		01
RA30	RE047220	Resistor Array	22KX4		01
RA31	RE047220	Resistor Array	22KX4		01
RA34	RE047220	Resistor Array	22KX4		01
RA35	RE047220	Resistor Array	22KX4		01
R1	RD357220	Carbon Resistor (chip)	22K 63M J		01
R2	RD357220	Carbon Resistor (chip)	22K 63M J		01
R3	RD356100	Carbon Resistor (chip)	1.0K 63M J		01
R4	RD356100	Carbon Resistor (chip)	1.0K 63M J		01
R5	RD356470	Carbon Resistor (chip)	4.7K 63M J		01
R6	RD356470	Carbon Resistor (chip)	4.7K 63M J		01
R7	RD355220	Carbon Resistor (chip)	220 63M J		01
R8	RD355220	Carbon Resistor (chip)	220 63M J		01
R9	RD355220	Carbon Resistor (chip)	220 63M J		01
R10	RD356470	Carbon Resistor (chip)	4.7K 63M J		01
R11	RD154470	Carbon Resistor (chip)	47.0 1/4 J		01
R12	RD154470	Carbon Resistor (chip)	47.0 1/4 J		01
R13	RD357100	Carbon Resistor (chip)	10K 63M J		01
R14	RD357100	Carbon Resistor (chip)	10K 63M J		01
R15	RD357100	Carbon Resistor (chip)	10K 63M J		01
R16	RD355220	Carbon Resistor (chip)	220 63M J		01
R17	RD355220	Carbon Resistor (chip)	220 63M J		01
R18	RD357100	Carbon Resistor (chip)	10K 63M J		01
R19	RD357100	Carbon Resistor (chip)	10K 63M J		01
R20	RD356100	Carbon Resistor (chip)	1.0K 63M J		01
R21	RD357220	Carbon Resistor (chip)	22K 63M J		01
R22	RD357240	Carbon Resistor (chip)	24K 63M J		01
R23	RD357240	Carbon Resistor (chip)	24K 63M J		01
R24	RD355100	Carbon Resistor (chip)	100 63M J		01
R25	RD355100	Carbon Resistor (chip)	100 63M J		01

*: New Parts

RANK: Japan only

REF NO.	PART NO.	DESCRIPTION	REMARKS	QTY	RANK
R26	RD355100	Carbon Resistor (chip)	100 63M J		01
R27	RD350000	Carbon Resistor (chip)	0 63M J		01
R28	RD350000	Carbon Resistor (chip)	0 63M J		01
R29	RD355100	Carbon Resistor (chip)	100 63M J		01
R30	RD355100	Carbon Resistor (chip)	100 63M J		01
R31	RD355100	Carbon Resistor (chip)	100 63M J		01
R32	RD357100	Carbon Resistor (chip)	10K 63M J		01
R33	RD357100	Carbon Resistor (chip)	10K 63M J		01
R34	RD357220	Carbon Resistor (chip)	22K 63M J		01
R35	RD355100	Carbon Resistor (chip)	100 63M J		01
R36	RD357100	Carbon Resistor (chip)	10K 63M J		01
R37	RD357100	Carbon Resistor (chip)	10K 63M J		01
R38	RD357100	Carbon Resistor (chip)	10K 63M J		01
R39	RD355100	Carbon Resistor (chip)	100 63M J		01
R42	RD356100	Carbon Resistor (chip)	1.0K 63M J		01
R43	RD356100	Carbon Resistor (chip)	1.0K 63M J		01
R44	RD357220	Carbon Resistor (chip)	22K 63M J		01
R45	RD355220	Carbon Resistor (chip)	220 63M J		01
R46	RD357220	Carbon Resistor (chip)	22K 63M J		01
R47	RD356680	Carbon Resistor (chip)	6.8K 63M J		01
R48	RD356680	Carbon Resistor (chip)	6.8K 63M J		01
R49	RD350000	Carbon Resistor (chip)	0 63M J		01
R50	RD357120	Carbon Resistor (chip)	12K 63M J		01
R51	RD357120	Carbon Resistor (chip)	12K 63M J		01
R53	RD356680	Carbon Resistor (chip)	6.8K 63M J		01
R54	RD356680	Carbon Resistor (chip)	6.8K 63M J		01
R55	RD356470	Carbon Resistor (chip)	4.7K 63M J		01
R56	RD350000	Carbon Resistor (chip)	0 63M J		01
R58	RD358100	Carbon Resistor (chip)	100K 63M J		01
R59	RD357330	Carbon Resistor (chip)	33K 63M J		01
R60	RD155390	Carbon Resistor (chip)	390.0 1/4 J		01
R61	RD155390	Carbon Resistor (chip)	390.0 1/4 J		01
R62	RD155390	Carbon Resistor (chip)	390.0 1/4 J		01
R63	RD155390	Carbon Resistor (chip)	390.0 1/4 J		01
R64	RD155390	Carbon Resistor (chip)	390.0 1/4 J		01
R65	RD350000	Carbon Resistor (chip)	0 63M J		01
R66	RD356330	Carbon Resistor (chip)	3.3K 63M J		01
R67	RD350000	Carbon Resistor (chip)	0 63M J		01
R68	RD355330	Carbon Resistor (chip)	330 63M J		01
R69	RD354100	Carbon Resistor (chip)	10 63M J		01
R70	RD355150	Carbon Resistor (chip)	150 63M J		01
R72	RD356100	Carbon Resistor (chip)	1.0K 63M J		01
R73	RD155470	Carbon Resistor (chip)	470.0 1/4 J		01
R74	RD356100	Carbon Resistor (chip)	1.0K 63M J		01
R75	RD354560	Carbon Resistor (chip)	56 63M J		01
R76	RD357100	Carbon Resistor (chip)	10K 63M J		01
R77	RD354560	Carbon Resistor (chip)	56 63M J		01
R78	RD356150	Carbon Resistor (chip)	1.5K 63M J		01
R79	RD357100	Carbon Resistor (chip)	10K 63M J		01
R80	RD357220	Carbon Resistor (chip)	22K 63M J		01
R81	RD354560	Carbon Resistor (chip)	56 63M J		01
R82	RD357220	Carbon Resistor (chip)	22K 63M J		01
R83	RD354560	Carbon Resistor (chip)	56 63M J		01
R84	RD354560	Carbon Resistor (chip)	56 63M J		01
R85	RD357220	Carbon Resistor (chip)	22K 63M J		01
R86	RD357220	Carbon Resistor (chip)	22K 63M J		01
R87	RD354560	Carbon Resistor (chip)	56 63M J		01
R88	RD354560	Carbon Resistor (chip)	56 63M J		01
R89	RD354560	Carbon Resistor (chip)	56 63M J		01
R92	RD357220	Carbon Resistor (chip)	22K 63M J		01
R93	RD357220	Carbon Resistor (chip)	22K 63M J		01
R94	RD357220	Carbon Resistor (chip)	22K 63M J		01
R95	RD350000	Carbon Resistor (chip)	0 63M J		01
R98	RD350000	Carbon Resistor (chip)	0 63M J		01
R100	RD357220	Carbon Resistor (chip)	22K 63M J		01
R101	RD357220	Carbon Resistor (chip)	22K 63M J		01
R102	RD357220	Carbon Resistor (chip)	22K 63M J		01
R103	RD355220	Carbon Resistor (chip)	220 63M J		01
R104	RD356100	Carbon Resistor (chip)	1.0K 63M J		01
R105	RD356100	Carbon Resistor (chip)	1.0K 63M J		01

*: New Parts

RANK: Japan only

REF NO.	PART NO.	DESCRIPTION	REMARKS	QTY	RANK
R106	RD358100	Carbon Resistor (chip)	100K 63M J		01
R107	RD358100	Carbon Resistor (chip)	100K 63M J		01
R108	RD357220	Carbon Resistor (chip)	22K 63M J		01
R109	RD357220	Carbon Resistor (chip)	22K 63M J		01
R110	RD355100	Carbon Resistor (chip)	100 63M J		01
R111	RD354560	Carbon Resistor (chip)	56 63M J		01
R112	RD357220	Carbon Resistor (chip)	22K 63M J		01
R113	RD357220	Carbon Resistor (chip)	22K 63M J		01
R114	RD357220	Carbon Resistor (chip)	22K 63M J		01
R115	RD357220	Carbon Resistor (chip)	22K 63M J		01
R116	RD350000	Carbon Resistor (chip)	0 63M J		01
R117	RD350000	Carbon Resistor (chip)	0 63M J		01
SW1	V4577800	Push Switch	SDKLA10200	standby on	03
TH1	VV111400	Poly Switch	SMD075-2 SMD		03
TR1	VD303700	Transistor	2SC3326 A,B TE85R		01
TR2	VD303700	Transistor	2SC3326 A,B TE85R		01
TR3	VJ927200	Transistor	2SA1162 O,Y		01
TR4	VD303700	Transistor	2SC3326 A,B TE85R		01
X1	VZ703600	Quartz Crystal Unit	8.4672M SMD-49		03
ZD1	VU171500	Zener Diode	UDZ 3.6BTE-17 3.6V		01
* CN1	V4886400	Circuit Board	LED J	(XZ192D0)	
LD1	--	Connector	HLW 16P SE	(V675910)	
LD2	V5640100	LED Display	LB-602VA2		04
LD3	V3990400	LED Display	LB-602VA2		04
LD4	V3990400	LED	TLOU1008	SONG	01
LD5	V3990400	LED	TLOU1008	PITCH	01
LD6	V3990400	LED	TLOU1008	INST SEL	01
LD7	V3990400	LED	TLOU1008	PATTERN	01
LD8	V3990400	LED	TLOU1008	GATE TIME	01
LD9	V3990400	LED	TLOU1008	BPM	01
LD10	V3990400	LED	TLOU1008	STORE	01
LD11	V3990400	LED	TLOU1008	VELOCITY	01
				BEAT	01
* 20	V4886200	Circuit Board	PN J	(XZ191C0)	
CN1	V6679800	LED Spacer			
CN2	VS666700	Connector	SLW 16P TE		02
CN3	--	Connector Assembly	15P-220	(VZ29860)	
CN4	--	Connector Assembly	4P-380	(VU65380)	
CN5	--	Connector Assembly	6P-200	(V636120)	
CN6	VB390300	Connector Base Post	PH- 7P TE		01
C1	VB390300	Connector Base Post	PH- 7P TE		01
C2	US135100	Ceramic Capacitor-F (chip)	0.1000 16V Z		01
C3	US135100	Ceramic Capacitor-F (chip)	0.1000 16V Z		01
C4	US135100	Ceramic Capacitor-F (chip)	0.1000 16V Z		01
C5	US135100	Ceramic Capacitor-F (chip)	0.1000 16V Z		01
C6	US135100	Ceramic Capacitor-F (chip)	0.1000 16V Z		01
C7	US135100	Ceramic Capacitor-F (chip)	0.1000 16V Z		01
C8	US135100	Ceramic Capacitor-F (chip)	0.1000 16V Z		01
C9	US135100	Ceramic Capacitor-F (chip)	0.1000 16V Z		01
C10	UF138220	Electrolytic Cap. (chip)	220 16V UUR1C2		01
C11	US135100	Ceramic Capacitor-F (chip)	0.1000 16V Z		01
C12	US135100	Ceramic Capacitor-F (chip)	0.1000 16V Z		01
C13	US135100	Ceramic Capacitor-F (chip)	0.1000 16V Z		01
C14	US135100	Ceramic Capacitor-F (chip)	0.1000 16V Z		01
C15	US135100	Ceramic Capacitor-F (chip)	0.1000 16V Z		01
C16	US135100	Ceramic Capacitor-F (chip)	0.1000 16V Z		01
C17	US135100	Ceramic Capacitor-F (chip)	0.1000 16V Z		01
C18	UF037470	Electrolytic Cap. (chip)	47 16V		01
C19	UF037470	Electrolytic Cap. (chip)	47 16V		01
C20	US064100	Ceramic Capacitor-B (chip)	0.0100 50V K		01
C21	US064100	Ceramic Capacitor-B (chip)	0.0100 50V K		01
C22	US064100	Ceramic Capacitor-B (chip)	0.0100 50V K		01
C23	US064100	Ceramic Capacitor-B (chip)	0.0100 50V K		01
C24	US064100	Ceramic Capacitor-B (chip)	0.0100 50V K		01
C25	US064100	Ceramic Capacitor-B (chip)	0.0100 50V K		01
C26	US064100	Ceramic Capacitor-B (chip)	0.0100 50V K		01
C27	US064100	Ceramic Capacitor-B (chip)	0.0100 50V K		01

*: New Parts

RANK: Japan only

REF NO.	PART NO.	DESCRIPTION		REMARKS	QTY	RANK
C28	US064100	Ceramic Capacitor-B (chip)	0.0100 50V K			01
C29	US064100	Ceramic Capacitor-B (chip)	0.0100 50V K			01
C30	US064100	Ceramic Capacitor-B (chip)	0.0100 50V K			01
C31	US064100	Ceramic Capacitor-B (chip)	0.0100 50V K			01
C32	US064100	Ceramic Capacitor-B (chip)	0.0100 50V K			01
C33	US064100	Ceramic Capacitor-B (chip)	0.0100 50V K			01
C34	US064100	Ceramic Capacitor-B (chip)	0.0100 50V K			01
C35	US064100	Ceramic Capacitor-B (chip)	0.0100 50V K			01
C36	UF038100	Electrolytic Cap. (chip)	100 16V			01
C37	UF038100	Electrolytic Cap. (chip)	100 16V			01
C38	UF038100	Electrolytic Cap. (chip)	100 16V			01
D1	VT332900	Diode	1SS355 TE-17			01
D2	VT332900	Diode	1SS355 TE-17			01
D3	VT332900	Diode	1SS355 TE-17			01
D4	VT332900	Diode	1SS355 TE-17			01
D5	VT332900	Diode	1SS355 TE-17			01
D6	VT332900	Diode	1SS355 TE-17			01
D7	VT332900	Diode	1SS355 TE-17			01
D8	VT332900	Diode	1SS355 TE-17			01
D9	VT332900	Diode	1SS355 TE-17			01
D10	VT332900	Diode	1SS355 TE-17			01
D11	VT332900	Diode	1SS355 TE-17			01
D12	VT332900	Diode	1SS355 TE-17			01
D13	VT332900	Diode	1SS355 TE-17			01
D14	VT332900	Diode	1SS355 TE-17			01
D15	VT332900	Diode	1SS355 TE-17			01
D16	VT332900	Diode	1SS355 TE-17			01
D17	VT332900	Diode	1SS355 TE-17			01
D18	VT332900	Diode	1SS355 TE-17			01
D19	VT332900	Diode	1SS355 TE-17			01
D20	VT332900	Diode	1SS355 TE-17			01
D21	VT332900	Diode	1SS355 TE-17			01
D22	VT332900	Diode	1SS355 TE-17			01
D23	VT332900	Diode	1SS355 TE-17			01
D24	VT332900	Diode	1SS355 TE-17			01
D25	VT332900	Diode	1SS355 TE-17			01
D26	VT332900	Diode	1SS355 TE-17			01
D27	VT332900	Diode	1SS355 TE-17			01
D28	VT332900	Diode	1SS355 TE-17			01
D29	VT332900	Diode	1SS355 TE-17			01
D30	VT332900	Diode	1SS355 TE-17			01
D31	VT332900	Diode	1SS355 TE-17			01
D32	VT332900	Diode	1SS355 TE-17			01
D33	VT332900	Diode	1SS355 TE-17			01
D34	VT332900	Diode	1SS355 TE-17			01
D35	VT332900	Diode	1SS355 TE-17			01
D36	VT332900	Diode	1SS355 TE-17			01
D37	VT332900	Diode	1SS355 TE-17			01
D38	VT332900	Diode	1SS355 TE-17			01
D39	VT332900	Diode	1SS355 TE-17			01
D40	VT332900	Diode	1SS355 TE-17			01
D41	VT332900	Diode	1SS355 TE-17			01
D42	VT332900	Diode	1SS355 TE-17			01
D43	VT332900	Diode	1SS355 TE-17			01
D44	VT332900	Diode	1SS355 TE-17			01
D45	VT332900	Diode	1SS355 TE-17			01
D46	VT332900	Diode	1SS355 TE-17			01
D47	VT332900	Diode	1SS355 TE-17			01
D48	VT332900	Diode	1SS355 TE-17			01
D49	VT332900	Diode	1SS355 TE-17			01
D50	VT332900	Diode	1SS355 TE-17			01
D51	VT332900	Diode	1SS355 TE-17			01
EC1	VV637500	Rotary Encoder	REB161(9x5)PVB15FH	DATA		03
IC1	XU533A00	IC	HD74HC273FP	D-FF		03
IC1	XY198A00	IC	MM74HC273SJX	D-FF		03
IC2	XU533A00	IC	HD74HC273FP	D-FF		03
IC2	XY198A00	IC	MM74HC273SJX	D-FF		03
IC3	XS720A00	IC	TC74HC245AF	TRANSCEIVER		03
IC3	XV611A00	IC	HD74HC245FPV	TRANSCEIVER		03
IC3	XW107A00	IC	MM74HC245ASJX	TRANSCEIVER		03

*: New Parts

RANK: Japan only

REF NO.	PART NO.	DESCRIPTION	REMARKS	QTY	RANK	
IC4	XU533A00	IC	HD74HC273FP	D-FF	03	
IC4	XY198A00	IC	MM74HC273SJX	D-FF	03	
IC5	XU533A00	IC	HD74HC273FP	D-FF	03	
IC5	XY198A00	IC	MM74HC273SJX	D-FF	03	
IC6	XU533A00	IC	HD74HC273FP	D-FF	03	
IC6	XY198A00	IC	MM74HC273SJX	D-FF	03	
IC7	XP373A00	IC	HD74HC4051FPEL	MULTIPLEXER	02	
IC7	XY549A00	IC	TC74HC4051AFEL	MULTIPLEXER	02	
IC8	XP373A00	IC	HD74HC4051FPEL	MULTIPLEXER	02	
IC8	XY549A00	IC	TC74HC4051AFEL	MULTIPLEXER	02	
IC9	XR294A00	IC	NJM3414AM(T1)	OP AMP	02	
LD1	V3990400	LED	TLOU1008	REC	01	
LD2	V3990400	LED	TLOU1008	PLAY/STOP	01	
LD3	V3990400	LED	TLOU1008	KEYBOARD	01	
LD4	V3990400	LED	TLOU1008	TG TRACK	01	
LD5	V3990400	LED	TLOU1008	SWING	01	
LD6	V3990400	LED	TLOU1008	OCT<<	01	
LD7	V3990400	LED	TLOU1008	TAP	01	
LD8	V3990400	LED	TLOU1008	PATTERN SELECT	01	
LD9	V3990400	LED	TLOU1008	SFX TRACK	01	
LD10	V3990400	LED	TLOU1008	REVERSE	01	
LD11	V3990400	LED	TLOU1008	OCT>>	01	
*	LD12	V6486700	LED	LN282RPX RED	1	
*	LD13	V6486700	LED	LN282RPX RED	2	
*	LD14	V6486700	LED	LN282RPX RED	3	
LD15	V3990400	LED	TLOU1008	STEP 1-8	01	
LD16	V3990400	LED	TLOU1008	STEP 9-16	01	
*	LD17	V6487000	LED	LN282RPX-(TX3) RED	POLY	
*	LD18	V6487000	LED	LN282RPX-(TX3) RED	MONO	
*	LD19	V6487000	LED	LN282RPX-(TX3) RED	UNISON	
LD20	V3990400	LED	TLOU1008	1	01	
LD21	V3990400	LED	TLOU1008	9	01	
*	LD22	V6487000	LED	LN282RPX-(TX3) RED	SAW	
*	LD23	V6487000	LED	LN282RPX-(TX3) RED	PULSE	
*	LD24	V6487000	LED	LN282RPX-(TX3) RED	MIX	
*	LD25	V6487000	LED	LN282RPX-(TX3) RED	VARI	
*	LD26	V6487000	LED	LN282RPX-(TX3) RED	MLT SAW	
LD27	V3990400	LED	TLOU1008	2	01	
LD28	V3990400	LED	TLOU1008	10	01	
LD29	V3990400	LED	TLOU1008	3	01	
LD30	V3990400	LED	TLOU1008	11	01	
*	LD31	V6487000	LED	LN282RPX-(TX3) RED	OFF	
*	LD32	V6487000	LED	LN282RPX-(TX3) RED	VCO1, M>S	
*	LD34	V6487000	LED	LN282RPX-(TX3) RED	VCO2, >1	
LD35	V3990400	LED	TLOU1008	4	01	
LD36	V3990400	LED	TLOU1008	12	01	
LD37	V3990400	LED	TLOU1008	5	01	
*	LD38	V6487000	LED	LN282RPX-(TX3) RED	SAW	
*	LD39	V6487000	LED	LN282RPX-(TX3) RED	PULSE	
*	LD40	V6487000	LED	LN282RPX-(TX3) RED	MIX	
*	LD41	V6487000	LED	LN282RPX-(TX3) RED	TRI	
LD42	V6487000	LED	LN282RPX-(TX3) RED	SINE		
LD43	V3990400	LED	TLOU1008	13	01	
LD44	VU067800	LED	SEL6210S-TP5 RED	1	01	
LD45	VU067800	LED	SEL6210S-TP5 RED	2	01	
LD46	V3990400	LED	TLOU1008	6	01	
LD47	V3990400	LED	TLOU1008	14	01	
*	LD48	V6487000	LED	LN282RPX-(TX3) RED	DELAY	
*	LD49	V6487000	LED	LN282RPX-(TX3) RED	FLGR	
*	LD50	V6487000	LED	LN282RPX-(TX3) RED	PHSR	
*	LD51	V6487000	LED	LN282RPX-(TX3) RED	OD+AMP	
LD52	V3990400	LED	TLOU1008	7	01	
LD53	V3990400	LED	TLOU1008	15	01	
LD54	V3990400	LED	TLOU1008	8	01	
LD55	VU067800	LED	SEL6210S-TP5 RED	1	01	
LD56	VU067800	LED	SEL6210S-TP5 RED	3	01	
LD57	V3990400	LED	TLOU1008	16	01	
*	LD58	V6487000	LED	LN282RPX-(TX3) RED	FEG	
*	LD59	V6487000	LED	LN282RPX-(TX3) RED	AEG	
LD60	VU067800	LED	SEL6210S-TP5 RED	2	01	

*: New Parts

RANK: Japan only

REF NO.	PART NO.	DESCRIPTION		REMARKS	QTY	RANK
LD61	VU067800	LED	SEL6210S-TP5 RED	4		01
LD62	VU067800	LED	SEL6210S-TP5 RED	SWITCH		01
RA1	RE047470	Resistor Array	47KX4			01
RA2	RE047220	Resistor Array	22KX4			01
RA3	RE047470	Resistor Array	47KX4			01
RA4	RE047220	Resistor Array	22KX4			01
RA5	RE047220	Resistor Array	22KX4			01
RA6	RE047220	Resistor Array	22KX4			01
R1	RD357220	Carbon Resistor (chip)	22K 63M J			01
R2	RD154680	Carbon Resistor (chip)	68.0 1/4 J			01
R3	RD154680	Carbon Resistor (chip)	68.0 1/4 J			01
R4	RD154680	Carbon Resistor (chip)	68.0 1/4 J			01
R5	RD154680	Carbon Resistor (chip)	68.0 1/4 J			01
R6	RD154680	Carbon Resistor (chip)	68.0 1/4 J			01
R7	RD154680	Carbon Resistor (chip)	68.0 1/4 J			01
R8	RD154680	Carbon Resistor (chip)	68.0 1/4 J			01
R9	RD154680	Carbon Resistor (chip)	68.0 1/4 J			01
R10	RD154680	Carbon Resistor (chip)	68.0 1/4 J			01
R11	RD154680	Carbon Resistor (chip)	68.0 1/4 J			01
R12	RD154680	Carbon Resistor (chip)	68.0 1/4 J			01
R13	RD154680	Carbon Resistor (chip)	68.0 1/4 J			01
R14	RD154680	Carbon Resistor (chip)	68.0 1/4 J			01
R15	RD154680	Carbon Resistor (chip)	68.0 1/4 J			01
R16	RD154680	Carbon Resistor (chip)	68.0 1/4 J			01
R17	RD154680	Carbon Resistor (chip)	68.0 1/4 J			01
R18	VI197400	Carbon Resistor (chip)	10.0K 1/10 D			01
R19	VI197400	Carbon Resistor (chip)	10.0K 1/10 D			01
R20	RD356100	Carbon Resistor (chip)	1.0K 63M J			01
R21	RD356100	Carbon Resistor (chip)	1.0K 63M J			01
R22	RD356100	Carbon Resistor (chip)	1.0K 63M J			01
R23	RD356100	Carbon Resistor (chip)	1.0K 63M J			01
R24	RD356100	Carbon Resistor (chip)	1.0K 63M J			01
R25	RD356100	Carbon Resistor (chip)	1.0K 63M J			01
R26	RD356100	Carbon Resistor (chip)	1.0K 63M J			01
R27	RD356100	Carbon Resistor (chip)	1.0K 63M J			01
R28	RD356100	Carbon Resistor (chip)	1.0K 63M J			01
R29	RD356100	Carbon Resistor (chip)	1.0K 63M J			01
R30	RD356100	Carbon Resistor (chip)	1.0K 63M J			01
R31	RD356100	Carbon Resistor (chip)	1.0K 63M J			01
R32	RD356100	Carbon Resistor (chip)	1.0K 63M J			01
R33	RD356100	Carbon Resistor (chip)	1.0K 63M J			01
R34	RD356100	Carbon Resistor (chip)	1.0K 63M J			01
R35	RD356100	Carbon Resistor (chip)	1.0K 63M J			01
SW1	VV439800	Tact Switch	SKQNAJ	SONG		01
SW2	VV439800	Tact Switch	SKQNAJ	SHOW VALUE		01
SW8	VV439800	Tact Switch	SKQNAJ	PATTERN		01
SW9	VV439800	Tact Switch	SKQNAJ	STORE		01
SW15	VV439800	Tact Switch	SKQNAJ	EXIT		01
SW20	VZ085500	Tact Switch	SKQNAM004A	KEY ASGN		01
SW21	VZ085500	Tact Switch	SKQNAM004A	DETAIL		01
SW24	VZ085500	Tact Switch	SKQNAM004A	WAVE		01
SW28	VZ085500	Tact Switch	SKQNAM004A	MODE		01
SW32	VZ085500	Tact Switch	SKQNAM004A	WAVE		01
SW35	VV600200	Tact Switch	SKQNAHD010	1		01
SW36	VV600200	Tact Switch	SKQNAHD010	2		01
SW39	VZ085500	Tact Switch	SKQNAM004A	TYPE		01
SW41	VZ085500	Tact Switch	SKQNAM004A	LENGTH		01
SW42	VZ085500	Tact Switch	SKQNAM004A	MODE		01
SW45	VV600200	Tact Switch	SKQNAHD010	1		01
SW46	VV600200	Tact Switch	SKQNAHD010	3		01
SW47	VZ085500	Tact Switch	SKQNAM004A	SELECT		01
SW49	VV600200	Tact Switch	SKQNAHD010	2		01
SW50	VV600200	Tact Switch	SKQNAHD010	4		01
SW51	VV600200	Tact Switch	SKQNAHD010	SWITCH		01
TA1	VQ248500	Transistor Array	TD62381F			04
TA2	VQ248500	Transistor Array	TD62381F			04
TA3	VT943400	Transistor Array	TD62785F(TP1)			04
VR1	V0075900	Rotary Variable Resistor	B 10.0K RK11K1130	PORTAMENTO		02
VR2	V0075900	Rotary Variable Resistor	B 10.0K RK11K1130	SPEED		02
VR3	V6788200	Rotary Variable Resistor	B 10.0K RK11K1130	VCO 1/2		02

*: New Parts

RANK: Japan only

REF NO.	PART NO.	DESCRIPTION		REMARKS	QTY	RANK
VR4	V0075900	Rotary Variable Resistor	B 10.0K RK11K1130	FM DEPTH		02
VR5	V0075900	Rotary Variable Resistor	B 10.0K RK11K1130	ATTACK		02
VR6	V0075900	Rotary Variable Resistor	B 10.0K RK11K1130	SYNC PITCH		02
VR7	V0075900	Rotary Variable Resistor	B 10.0K RK11K1130	SCENE		02
VR8	V0075900	Rotary Variable Resistor	B 10.0K RK11K1130	DECAY		02
VR9	V0075900	Rotary Variable Resistor	B 10.0K RK11K1130	NOISE LEVEL		02
VR10	V0075900	Rotary Variable Resistor	B 10.0K RK11K1130	SUSTAIN		02
VR11	V0075900	Rotary Variable Resistor	B 10.0K RK11K1130	RELEASE		02
VR12	V0075900	Rotary Variable Resistor	B 10.0K RK11K1130	CUTOFF/TYPE		02
VR13	V0075900	Rotary Variable Resistor	B 10.0K RK11K1130	PARAM/PAN		02
VR14	V0075900	Rotary Variable Resistor	B 10.0K RK11K1130	RESONANCE		02
VR15	V0075900	Rotary Variable Resistor	B 10.0K RK11K1130	WET/VOL		02
VR16	V0075900	Rotary Variable Resistor	B 10.0K RK11K1130	FEG DEPTH		02
VR17	VY691300	Rotary Variable Resistor	A 10.0K RK14K12D	VOLUME		03
	V4147400	Circuit Board	PLG150-AN	(XV952C0)		31
C1	UB051220	Monolithic Ceramic Cap.	SL 22P 50V J			01
C2	UB051220	Monolithic Ceramic Cap.	SL 22P 50V J			01
C3	UB245100	Monolithic Ceramic Cap.	F 0.100 25V Z			01
C5	UB245100	Monolithic Ceramic Cap.	F 0.100 25V Z			01
C6	UB245100	Monolithic Ceramic Cap.	F 0.100 25V Z			01
C7	UB245100	Monolithic Ceramic Cap.	F 0.100 25V Z			01
C8	UB245100	Monolithic Ceramic Cap.	F 0.100 25V Z			01
C9	UB245100	Monolithic Ceramic Cap.	F 0.100 25V Z			01
L1	VS740100	Chip Inductance	BLM21B751S 2125			03
L2	VS740100	Chip Inductance	BLM21B751S 2125			03
R1	RD256100	Carbon Resistor (chip)	1.0K 0.1 J			01
R2	RD255100	Carbon Resistor (chip)	100.0 0.1 J			01
R3	RD255100	Carbon Resistor (chip)	100.0 0.1 J			01
R4	RD256680	Carbon Resistor (chip)	6.8K 0.1 J			01
R5	RD250000	Carbon Resistor (chip)	0.0 0.0 J			01
R8	RD257100	Carbon Resistor (chip)	10.0K 0.1 J			01
X1	VP864900	Quartz Crystal Unit	16M SMD-49			04
CN1	VE389600	Base Post Connector	53015 15P SE			01
C10	UB044100	Monolithic Ceramic Cap.	F 0.010 50V Z			01
C11	UB245100	Monolithic Ceramic Cap.	F 0.100 25V Z			01
* C12	V4142800	Electrolytic Cap. (chip)	10UF 16V			
* C13	V4142800	Electrolytic Cap. (chip)	10UF 16V			
* C14	V4143000	Electrolytic Cap. (chip)	47UF 16V			
* C15	UB245100	Monolithic Ceramic Cap.	F 0.100 25V Z			01
* C16	V4142900	Electrolytic Cap. (chip)	22UF 16V			
C17	RD250000	Carbon Resistor (chip)	0.0 0.0 J			01
C18	RD250000	Carbon Resistor (chip)	0.0 0.0 J			01
C19	RD250000	Carbon Resistor (chip)	0.0 0.0 J			01
C20	RD250000	Carbon Resistor (chip)	0.0 0.0 J			01
C21	RD250000	Carbon Resistor (chip)	0.0 0.0 J			01
C22	RD250000	Carbon Resistor (chip)	0.0 0.0 J			01
C23	RD250000	Carbon Resistor (chip)	0.0 0.0 J			01
C24	RD250000	Carbon Resistor (chip)	0.0 0.0 J			01
C31	UB245100	Monolithic Ceramic Cap.	F 0.100 25V Z			01
C32	UB245100	Monolithic Ceramic Cap.	F 0.100 25V Z			01
C33	UB245100	Monolithic Ceramic Cap.	F 0.100 25V Z			01
C34	UB245100	Monolithic Ceramic Cap.	F 0.100 25V Z			01
C35	UB245100	Monolithic Ceramic Cap.	F 0.100 25V Z			01
* C36	V4142800	Electrolytic Cap. (chip)	10UF 16V			
C37	UB245100	Monolithic Ceramic Cap.	F 0.100 25V Z			01
C38	UB245100	Monolithic Ceramic Cap.	F 0.100 25V Z			01
C39	UB245100	Monolithic Ceramic Cap.	F 0.100 25V Z			01
C40	UB245100	Monolithic Ceramic Cap.	F 0.100 25V Z			01
C41	UB245100	Monolithic Ceramic Cap.	F 0.100 25V Z			01
C42	UB245100	Monolithic Ceramic Cap.	F 0.100 25V Z			01
* C43	V4142800	Electrolytic Cap. (chip)	10UF 16V			
* C44	UB245100	Monolithic Ceramic Cap.	F 0.100 25V Z			01
* C45	V4142800	Electrolytic Cap. (chip)	10UF 16V			
C46	UB245100	Monolithic Ceramic Cap.	F 0.100 25V Z			01
* IC1	XQ375A00	IC	HD6413002FP16	CPU		09
* IC3	XZ970100	IC	MBM29F800B	FLASH ROM V1.04		
IC4	XT013A00	IC	YSS236-F	VOP3		13
IC5	XP268A00	IC	YSS233-F	MDSP		12
IC6	XV077A00	IC	MSM514260C-60JS	DRAM 4M		07

*: New Parts

RANK: Japan only

REF NO.	PART NO.	DESCRIPTION		REMARKS	QTY	RANK
IC6	XV839A00	IC	SDM4260CLU-6S	DRAM 4M		08
IC7	XV077A00	IC	MSM514260C-60JS	DRAM 4M		07
IC7	XV839A00	IC	SDM4260CLU-6S	DRAM 4M		08
* IC8	XV894A00	IC	TC74VHC153FT	MULTIPLEXER		
* IC9	XV890A00	IC	TC74VHC14FT	INVERTER		
* IC9	XW711A00	IC	HD74LV14AT	INVERTER		
IC13	XU797A00	IC	TC74VHC245FT	BUFFER		03
IC13	XW744A00	IC	HD74LV245AT	BUFFER		
IC14	XV893A00	IC	TC74VHC139FT	DECODER		02
* IC14	XW712A00	IC	HD74LV139AT	DECODER		
* IC15	XV890A00	IC	TC74VHC14FT	INVERTER		
* IC15	XW711A00	IC	HD74LV14AT	INVERTER		
RA1	RE047100	Resistor Array	10KX4			01
RA2	RE047100	Resistor Array	10KX4			01
RA3	RE047100	Resistor Array	10KX4			01
RA4	RE047100	Resistor Array	10KX4			01
RA5	RE047100	Resistor Array	10KX4			01
RA6	RE047100	Resistor Array	10KX4			01
RA9	RE047100	Resistor Array	10KX4			01
R13	RD250000	Carbon Resistor (chip)	0.0 0.0 J			01
R14	RD257100	Carbon Resistor (chip)	10.0K 0.1 J			01
R15	RD257100	Carbon Resistor (chip)	10.0K 0.1 J			01
R16	RD257100	Carbon Resistor (chip)	10.0K 0.1 J			01
R17	RD257100	Carbon Resistor (chip)	10.0K 0.1 J			01
R18	RD257100	Carbon Resistor (chip)	10.0K 0.1 J			01
R19	RD257100	Carbon Resistor (chip)	10.0K 0.1 J			01
R20	RD257100	Carbon Resistor (chip)	10.0K 0.1 J			01
R21	RD257100	Carbon Resistor (chip)	10.0K 0.1 J			01
R22	RD254680	Carbon Resistor (chip)	68.0 0.1 J			01
R24	RD257100	Carbon Resistor (chip)	10.0K 0.1 J			01
RA10	RE047100	Resistor Array	10KX4			01
RA11	RE047100	Resistor Array	10KX4			01
RA12	RE047100	Resistor Array	10KX4			01
RA13	RE047100	Resistor Array	10KX4			01
RA14	RE047100	Resistor Array	10KX4			01
* V6554200	Rubber Contact			PLAY, TAP, REC, SWING, REVERSE, SHIFT, OCT<<, OCT>>, KEYBOARD, PATTERN SELECT, SYNTH TRACK, RHYTHM TRACK STEP 1-8, STEP 9-16, 1, 2, 3, 4, 5, 6, 7, 8, 9, 10, 11, 12, 13, 14, 15, 16		
* MFA16080	Connector Assembly		16P 80mm P=1.0			
VT368600	AC Adapter		PA-3B JP	J		09
VT368700	AC Adapter		PA-3B UC	U		
VT368800	AC Adapter		PA-3B CEE	E		08



*: New Parts

RANK: Japan only

AN200 OVERALL CIRCUIT DIAGRAM 1/3 (DM)

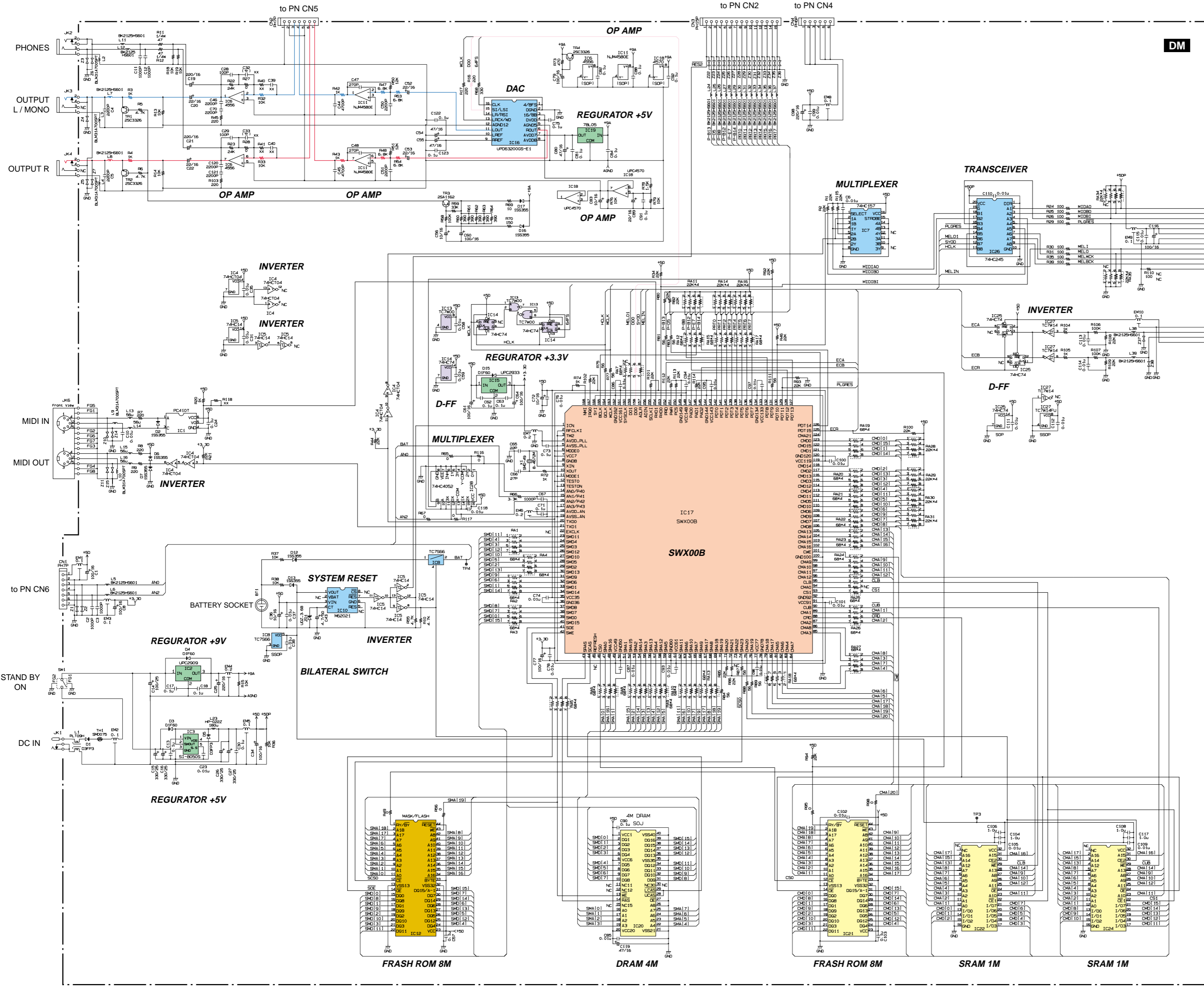

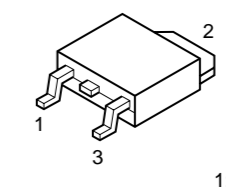
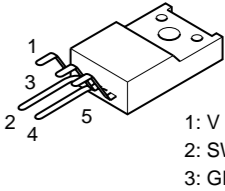
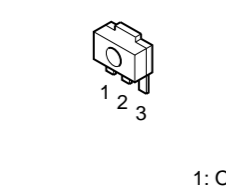
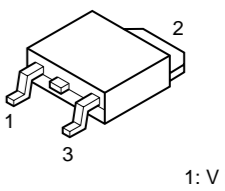
<p>• μPC2909T(XT441A00) REGULATOR +9V</p>  <p>1: V in 2: GND 3: V out</p>	<p>• SI-8050S(LF1103) (XT514A00) REGULATOR +5V</p>  <p>1: V in 2: SW out 3: GND 4: V os 5: S.S</p>
<p>• μNJM78L05UA(XJ598A00) REGULATOR +5V</p>  <p>1: OUTPUT 2: COMMON 3: INPUT</p>	<p>• μPC2933T(XS516A00) REGULATOR +3.3V</p>  <p>1: V in 2: GND 3: V out</p>

Battery VN10350
VN103600 (Battery holder for VN103500)

- Notice for back-up battery removal push the battery as shown in figure, then the battery will pop up.
- Druk de batterij neer beneden zoals aangeven in de tekening, de batterij springt dan naar voren.

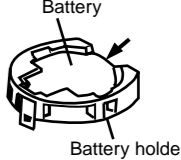

Battery holder

Note: See parts list for details of circuit board component parts.

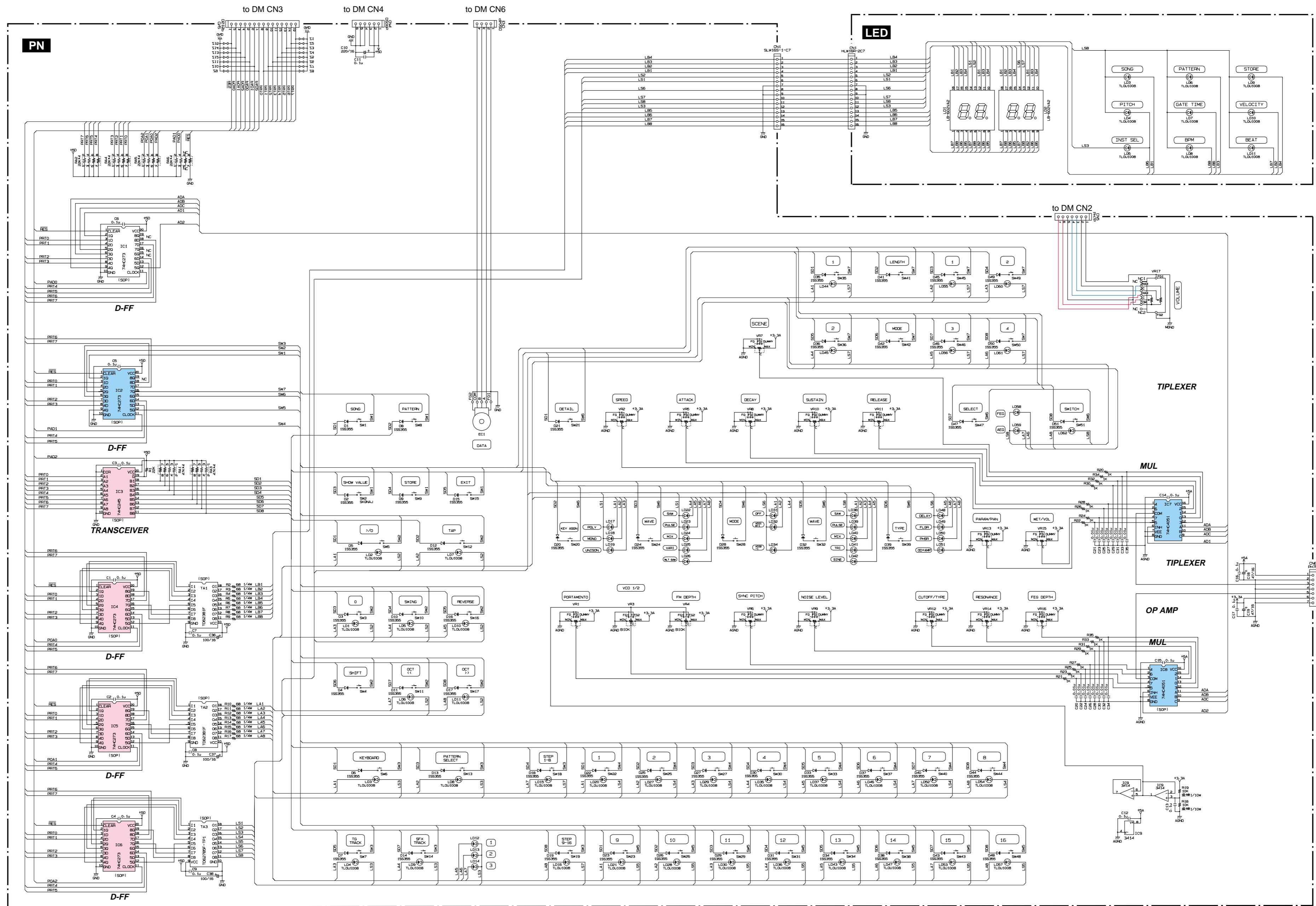

PN: 28CCI-8818206
LED: 28CCI-8818207

Note: See parts list for details of circuit board component parts.

AN200 OVERALL CIRCUIT DIAGRAM 3/3 (PLG150-AN)

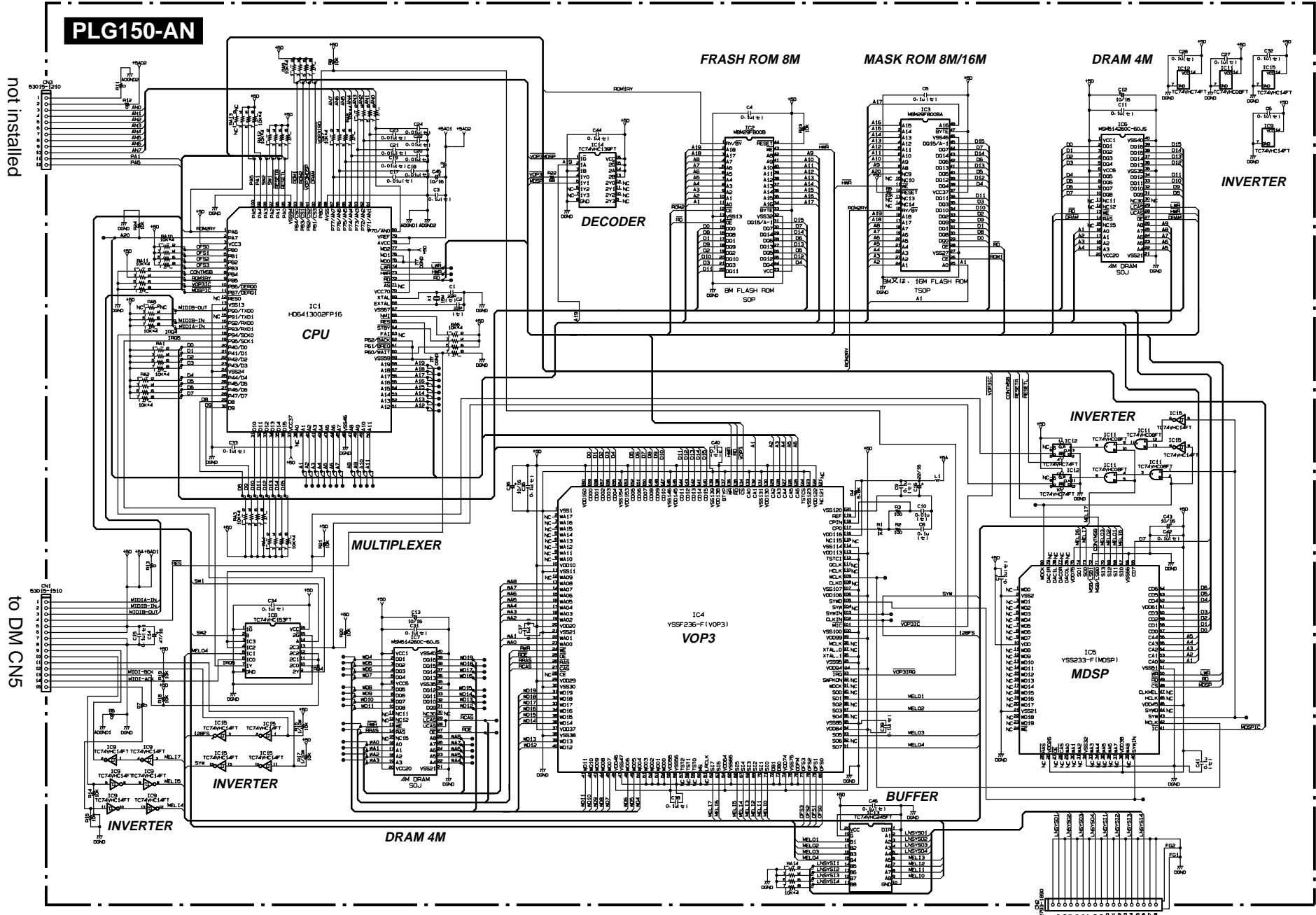

PLG150-AN

not installed

to DM CNS

28CA2-8814155

AN200

5

4

3

2

1

M

N

O

P

Q