

INTEGRATED AMPLIFIER A-S201

SERVICE MANUAL

A-S201

IMPORTANT NOTICE

This manual has been provided for the use of authorized Yamaha Retailers and their service personnel.

It has been assumed that basic service procedures inherent to the industry, and more specifically Yamaha Products, are already known and understood by the users, and have therefore not been restated.

WARNING: Failure to follow appropriate service and safety procedures when servicing this product may result in personal injury, destruction of expensive components, and failure of the product to perform as specified. For these reasons, we advise all Yamaha product owners that any service required should be performed by an authorized Yamaha Retailer or the appointed service representative.

IMPORTANT: The presentation or sale of this manual to any individual or firm does not constitute authorization, certification or recognition of any applicable technical capabilities, or establish a principle-agent relationship of any form.

The data provided is believed to be accurate and applicable to the unit(s) indicated on the cover. The research, engineering, and service departments of Yamaha are continually striving to improve Yamaha products. Modifications are, therefore, inevitable and specifications are subject to change without notice or obligation to retrofit. Should any discrepancy appear to exist, please contact the distributor's Service Division.

WARNING: Static discharges can destroy expensive components. Discharge any static electricity your body may have accumulated by grounding yourself to the ground buss in the unit (heavy gauge black wires connect to this buss).

IMPORTANT: Turn the unit OFF during disassembly and part replacement. Recheck all work before you apply power to the unit.

■ CONTENTS

TO SERVICE PERSONNEL	2	DISPLAY DATA	28
FRONT PANEL	3	IC DATA	29-31
REAR PANELS	3-5	BLOCK DIAGRAM	32
REMOTE CONTROL PANEL	6	WIRING DIAGRAM	33
SPECIFICATIONS	6-7	PRINTED CIRCUIT BOARDS	34-39
INTERNAL VIEW	8	PIN CONNECTION DIAGRAMS	40
SERVICE PRECAUTIONS	8	SCHEMATIC DIAGRAM	41
DISASSEMBLY PROCEDURES	9-11	REPLACEMENT PARTS LIST	43-49
UPDATING FIRMWARE	12-17	REMOTE CONTROL	50
SELF-DIAGNOSTIC FUNCTION	18-27	ADVANCED SETUP	51

101294

Copyright (c) Yamaha Corporation All rights reserved.
This manual is copyrighted by Yamaha and may not be copied or
redistributed either in print or electronically without permission.



YAMAHA CORPORATION
P.O.Box 1, Hamamatsu, Japan

'13.12

■ TO SERVICE PERSONNEL

1. Critical Components Information

Components having special characteristics are marked Δ and must be replaced with parts having specifications equal to those originally installed.

2. Leakage Current Measurement (For 120V Models Only)

When service has been completed, it is imperative to verify that all exposed conductive surfaces are properly insulated from supply circuits.

- Meter impedance should be equivalent to 1500 ohms shunted by 0.15 μ F.

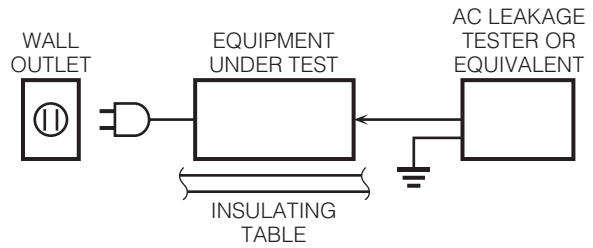

- Leakage current must not exceed 0.5mA.
- Be sure to test for leakage with the AC plug in both polarities.



For U model

“CAUTION”

“F1: FOR CONTINUED PROTECTION AGAINST RISK OF FIRE, REPLACE ONLY WITH SAME TYPE 8A, 125V FUSE.”

For C model

CAUTION

F1: REPLACE WITH SAME TYPE 8A, 125V FUSE.

ATTENTION

F1: UTILISER UN FUSIBLE DE RECHANGE DE MÊME TYPE DE 8A, 125V.

WARNING: CHEMICAL CONTENT NOTICE!

This product contains chemicals known to the State of California to cause cancer, or birth defects or other reproductive harm.

DO NOT PLACE SOLDER, ELECTRICAL/ELECTRONIC OR PLASTIC COMPONENTS IN YOUR MOUTH FOR ANY REASON WHATSOEVER!

Avoid prolonged, unprotected contact between solder and your skin! When soldering, do not inhale solder fumes or expose eyes to solder/flux vapor!

If you come in contact with solder or components located inside the enclosure of this product, wash your hands before handling food.

About lead free solder

All of the P.C.B.s installed in this unit and solder joints are soldered using the lead free solder.

Among some types of lead free solder currently available, it is recommended to use one of the following types for the repair work.

- Sn + Ag + Cu (tin + silver + copper)
- Sn + Cu (tin + copper)
- Sn + Zn + Bi (tin + zinc + bismuth)

Caution:

As the melting point temperature of the lead free solder is about 30°C to 40°C (50°F to 70°F) higher than that of the lead solder, be sure to use a soldering iron suitable to each solder.

FRONT PANEL

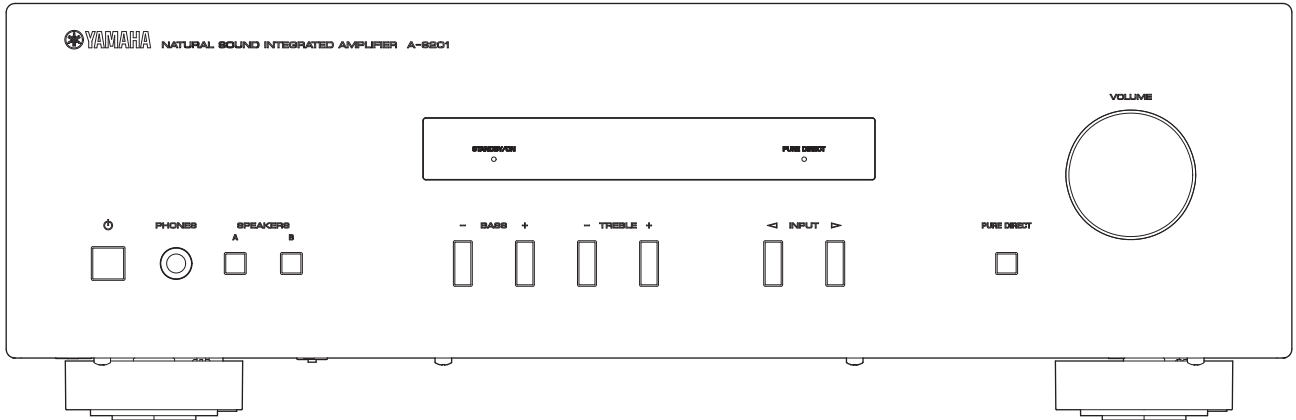

REAR PANELS

R model

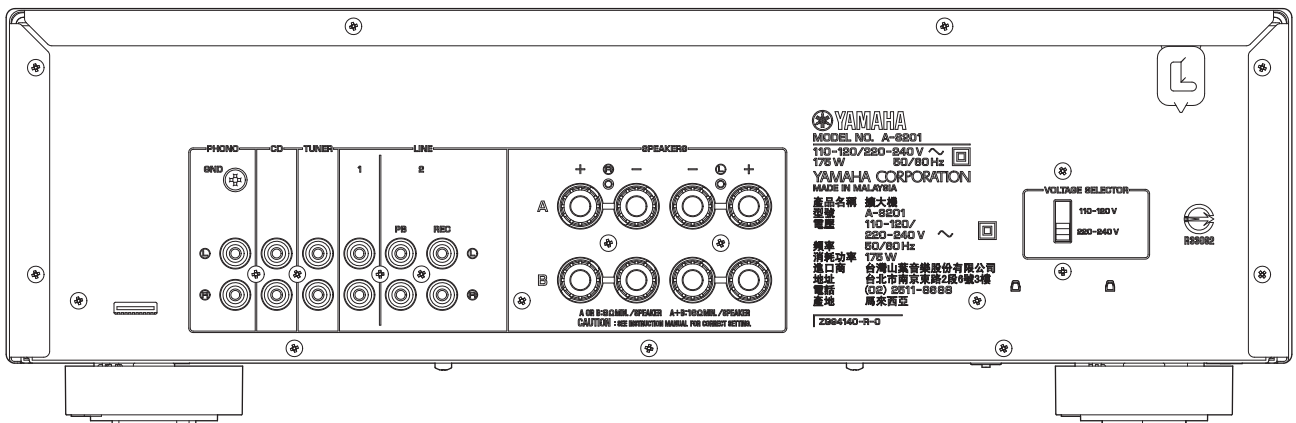

T model

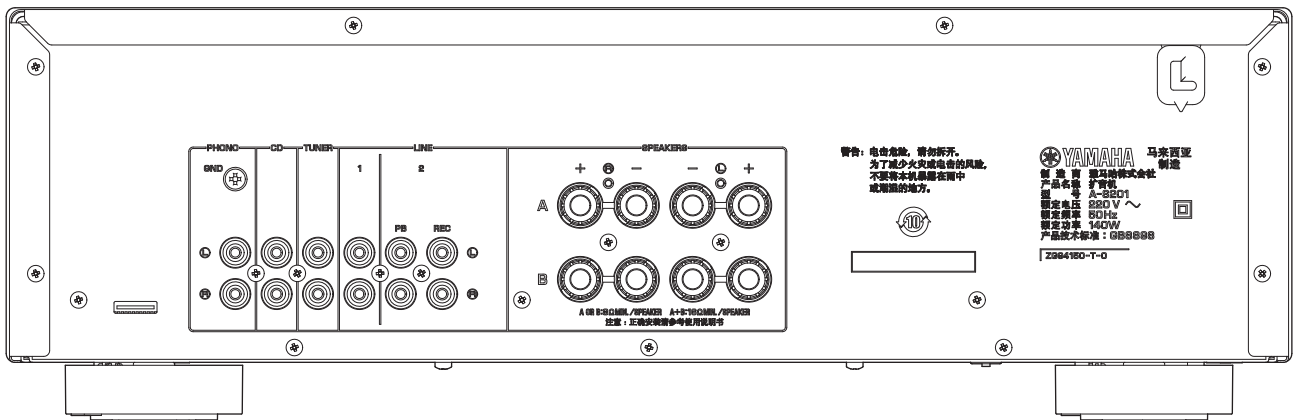

K model

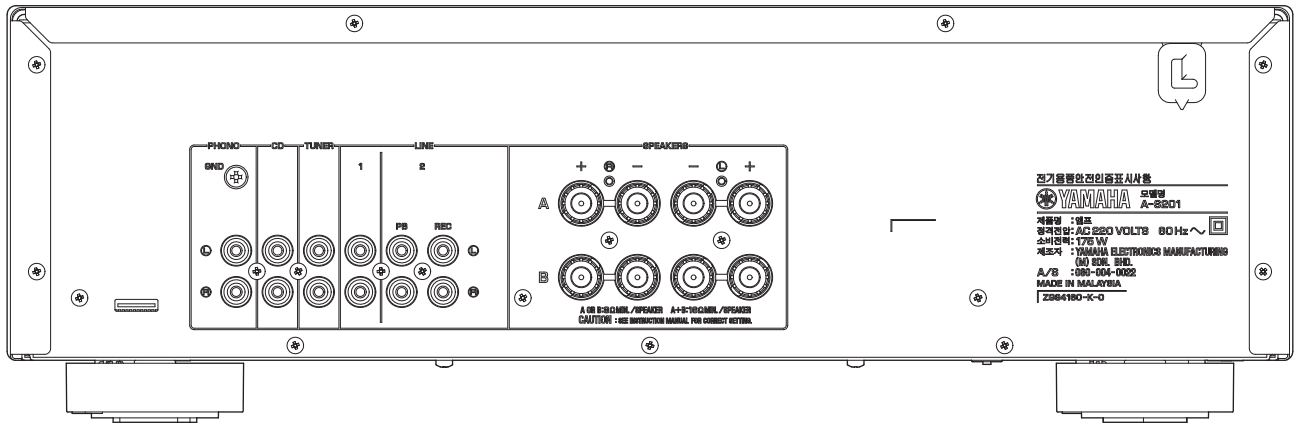

A model

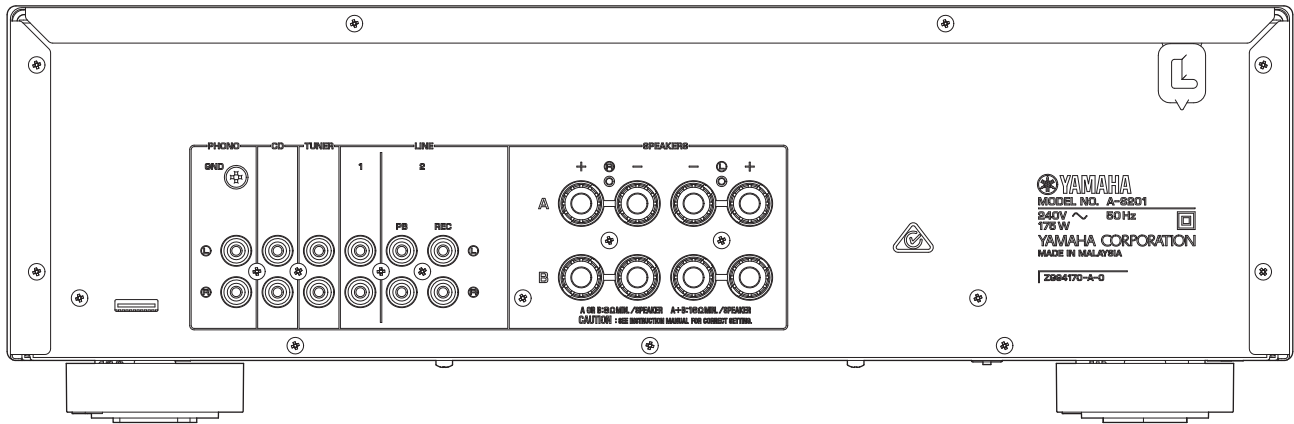

B, G models

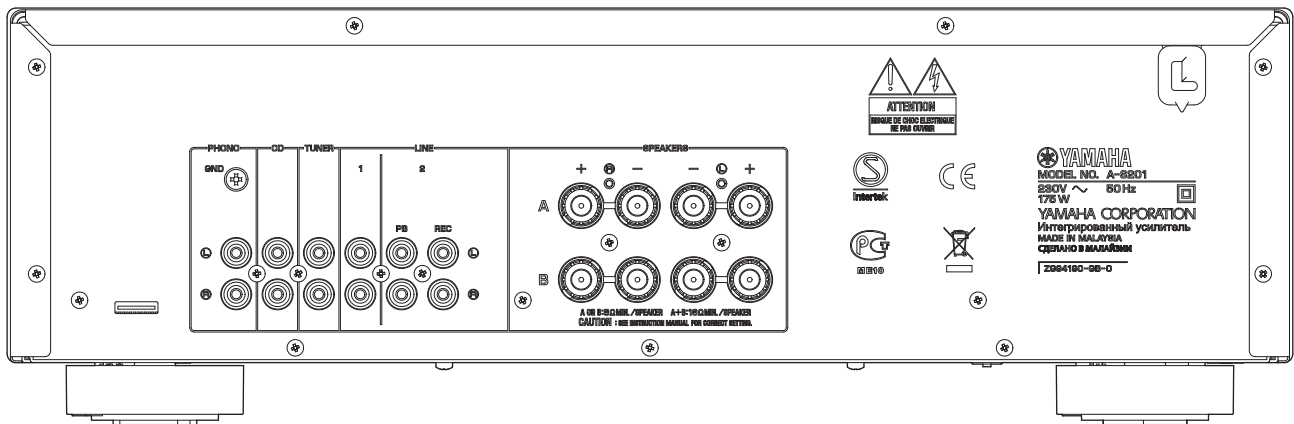

A-S201

L model

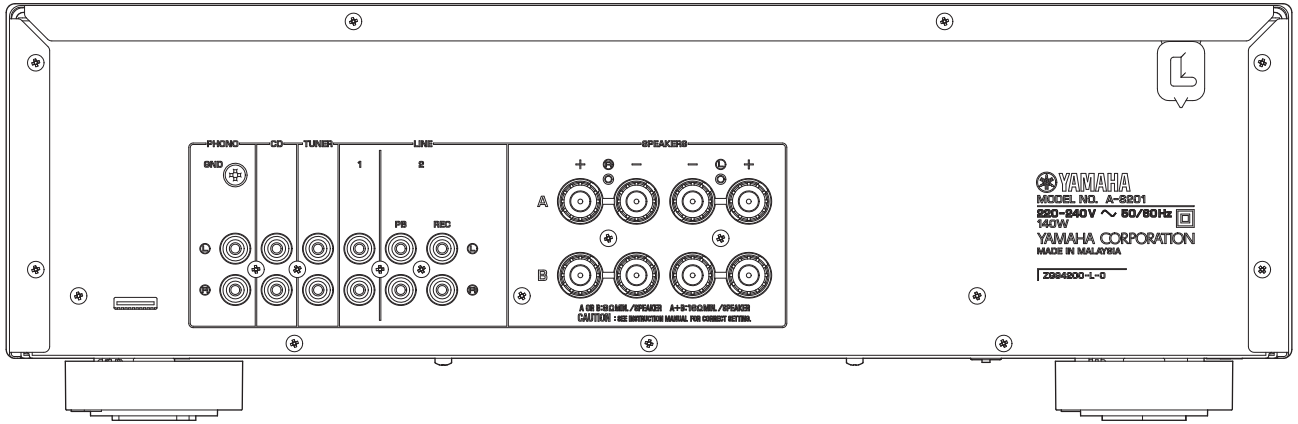

■ REMOTE CONTROL PANEL

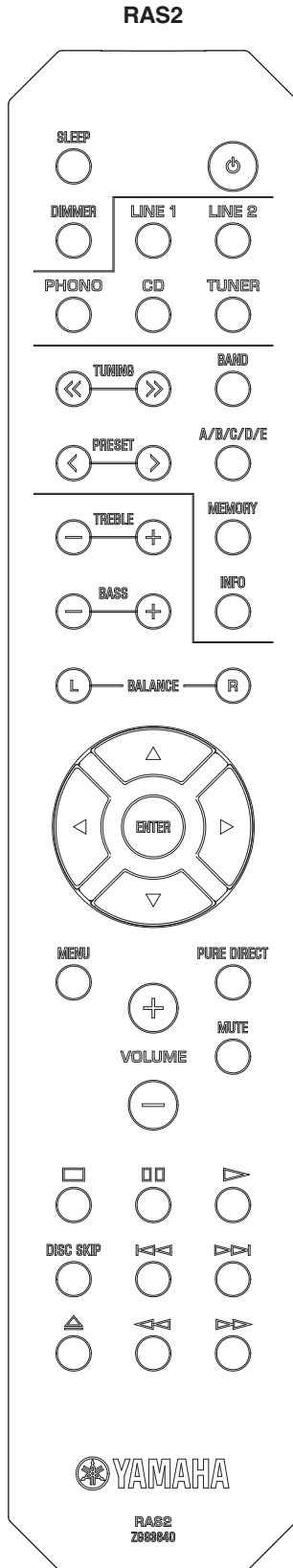

■ SPECIFICATIONS

■ Audio Section

Minimum RMS Output Power (Power Amp. Section)

(40 Hz to 20 kHz, 0.2 % THD, 8 ohms / L/R drive)

R, K, A, B, G models 100 W + 100 W

T, L models 85 W + 85 W

Dynamic Power Per Channel (IHF) [R, K, A, B, G models]

8 / 6 / 4 / 2 ohms 125 / 150 / 165 / 180 W

Maximum Power Per Channel (1 kHz, 0.7 % THD, 4 ohms)

[B, G models]

..... 115 W

Maximum Effective Output Power (JEITA)

(1 kHz, 10 % THD, 8 ohms) [R, T, L models]

R model 140 W

T, L models 125 W

Input Sensitivity/Input Impedance (1 kHz, 100 W/8 ohms)

PHONO (MM) 10.0 mV / 47 k-ohms

CD etc. 500 mV / 47 k-ohms

Output Level/Output Impedance

REC OUT 500 mV / 2.2 k-ohms

Headphone Jack Rated Output/Output Impedance

(1 kHz, 500 mV, 8 ohms load / CD etc. input)

..... 470 mV / 470 ohms

Frequency Response (CD etc.)

20 Hz to 20 kHz 0 ±0.5 dB

10 Hz to 100 kHz 0 ±3.0 dB

RIAA Equalization Deviation

PHONO (MM) ±0.5 dB

Total Harmonic Distortion (20 Hz to 20 kHz)

PHONO (MM) to REC OUT (2 V) 0.025 % or less

CD etc. to SP OUT (50 W/8 ohms) 0.2 % or less

Signal to Noise Ratio (IHF-A Network)

PHONO (MM)

Input shorted 10 mV 75 dB or more

CD etc. (PURE DIRECT on)

Input shorted 500 mV 100 dB or more

Residual Noise (IHF-A Network)

..... 70 µV

Tone Control Characteristics

Bass

Boost/Cut (50 Hz) ±10 dB

Turnover frequency 170 Hz

Treble

Boost/Cut (20 kHz) ±10 dB

Turnover frequency 3.0 kHz

A-S201

■ General

Power Supply

R model	AC 110-120/220-240 V, 50/60 Hz
T model	AC 220 V, 50 Hz
K model	AC 220 V, 60 Hz
A model	AC 240 V, 50 Hz
B, G models	AC 230 V, 50 Hz
L model	AC 220-240 V, 50/60 Hz

Power Consumption

R, K, A, B, G models	175 W
T, L models	140 W

Standby Power Consumption [T, K, A, B, G, L models]

.....0.5 W or less

Dimensions (W x H x D)

..... 435 x 141 x 333 mm (17-1/8" x 5-1/2" x 13-1/8")

Weight

..... 6.7 kg (14.8 lbs.)

Finish

R, T, K, A, B, G, L models	Black color
R, T, K, A, B, G, L models	Silver color

Accessories

Remote control	x 1
Battery (LR6, AA, UM-3)	x 2

* Specifications are subject to change without notice.

R.....*General model*
T.....*Chinese model*
K.....*Korean model*
A.....*Australian model*

B.....*British model*
G.....*European model*
L.....*Singapore model*

• DIMENSIONS

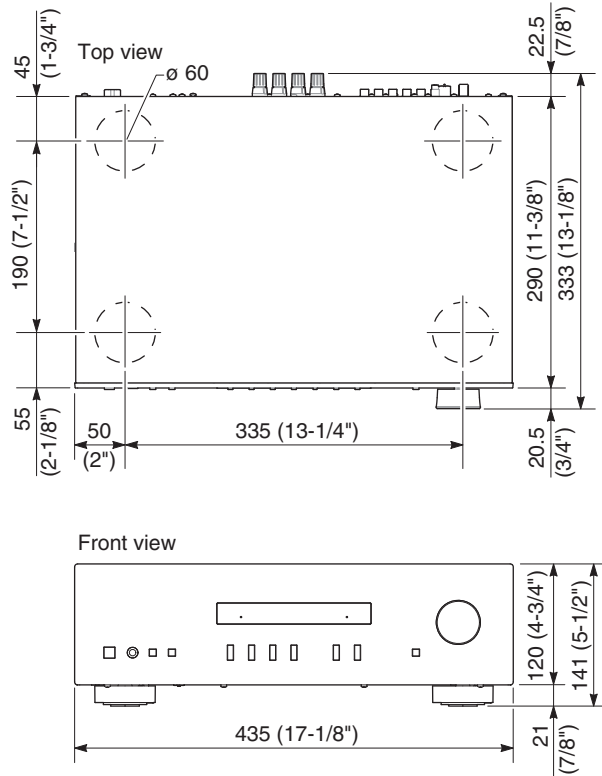

Unit: mm (inch)

A-S201

INTERNAL VIEW

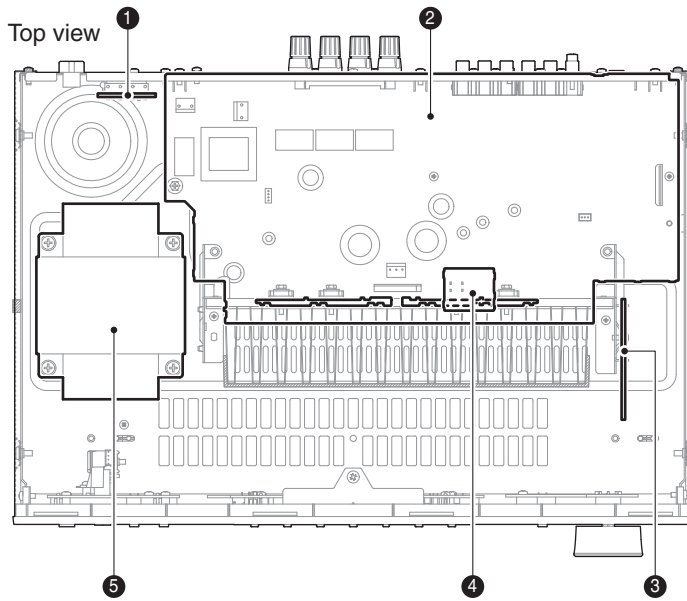

- ① MAIN (5) P.C.B. (R model)
- ② MAIN (1) P.C.B.
- ③ MAIN (8) P.C.B.
- ④ MAIN (7) P.C.B.
- ⑤ POWER TRANSFORMER
- ⑥ MAIN (6) P.C.B.
- ⑦ MAIN (3) P.C.B.
- ⑧ MAIN (2) P.C.B.
- ⑨ MAIN (4) P.C.B.

Front view

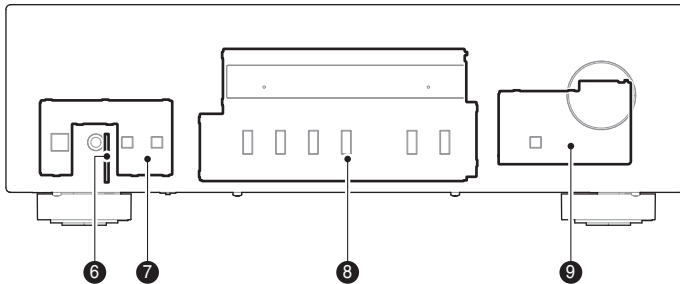

SERVICE PRECAUTIONS

Safety measures

- Some internal parts in this product contain high voltages and are dangerous. Be sure to take safety measures during servicing, such as wearing insulating gloves.
- Note that the capacitors indicated below are dangerous even after the power is turned off because an electric charge remains and a high voltage continues to exist there. Before starting any repair work, connect a discharging resistor (5 k-ohms/10 W) to the terminals of each capacitor indicated below to discharge electricity. The time required for discharging is about 30 seconds per each.

C140, C143, C149 and C150 on MAIN (1) P.C.B.

For details, refer to "PRINTED CIRCUIT BOARDS".

■ DISASSEMBLY PROCEDURES

(Remove parts in the order as numbered.)
Disconnect the power cable from the AC outlet.

1. Removal of Top Cover

- Remove screw (①), 4 screws (②) and 6 screws (③). (Fig. 1)
- Remove the top cover. (Fig. 1)

2. Removal of Front Panel Unit

- Remove screw (④) and 6 screws (⑤). (Fig. 1)
- Remove screw (⑥) and then remove W501. (Fig. 1)
- Remove CB102, CB204 and CB502. (Fig. 1)
- Release 2 hooks and then remove the front panel unit. (Fig. 1)

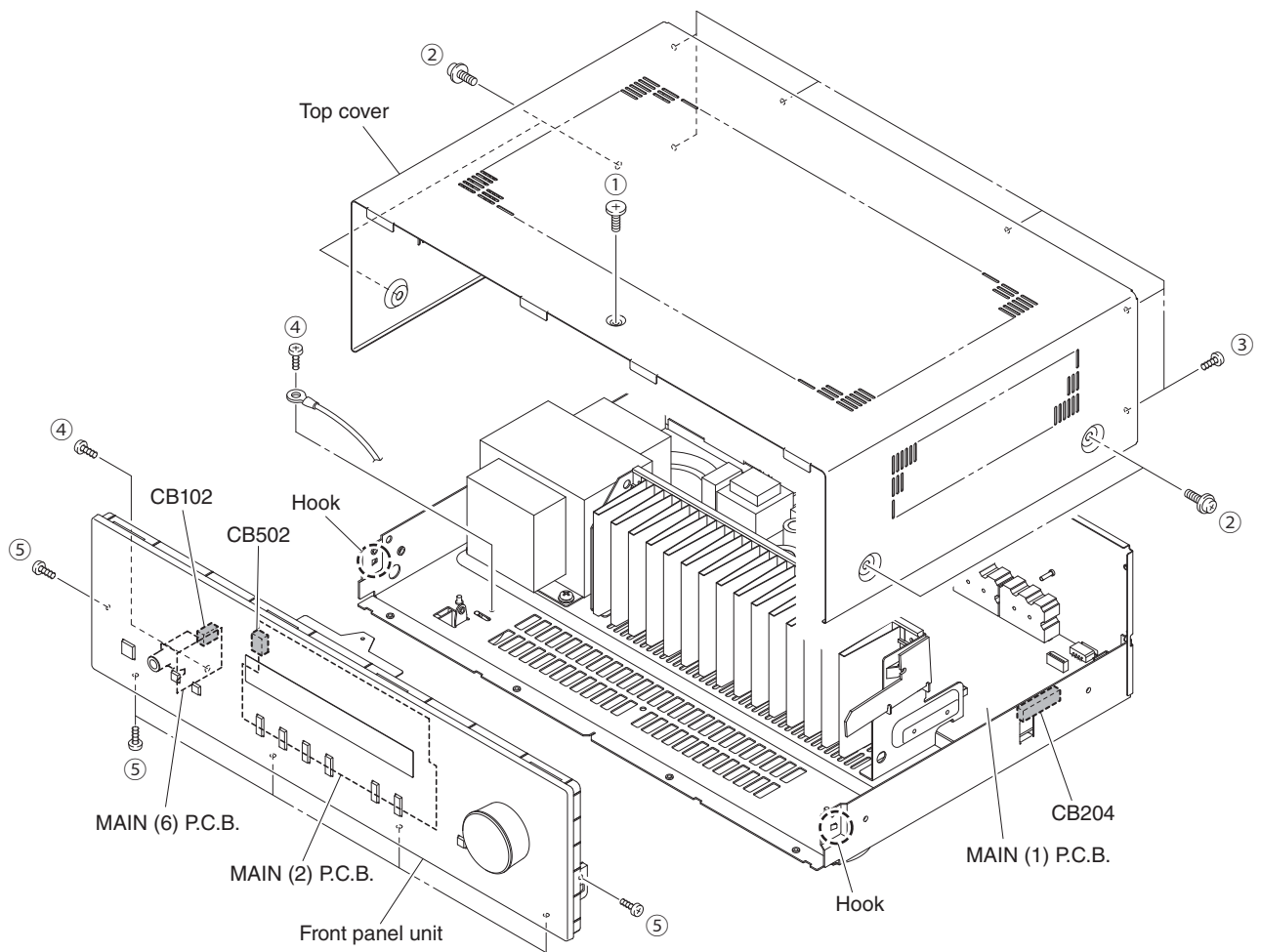

Fig. 1

3. Removal of AMP Unit

- a. Remove 12 screws (⑦). (Fig. 3)
- b. Remove 4 screws (⑧) and screw (⑨). (Fig. 2)
- c. Remove CB4, CB7 and CB103. (Fig. 2)
- d. Remove the AMP unit. (Fig. 2)

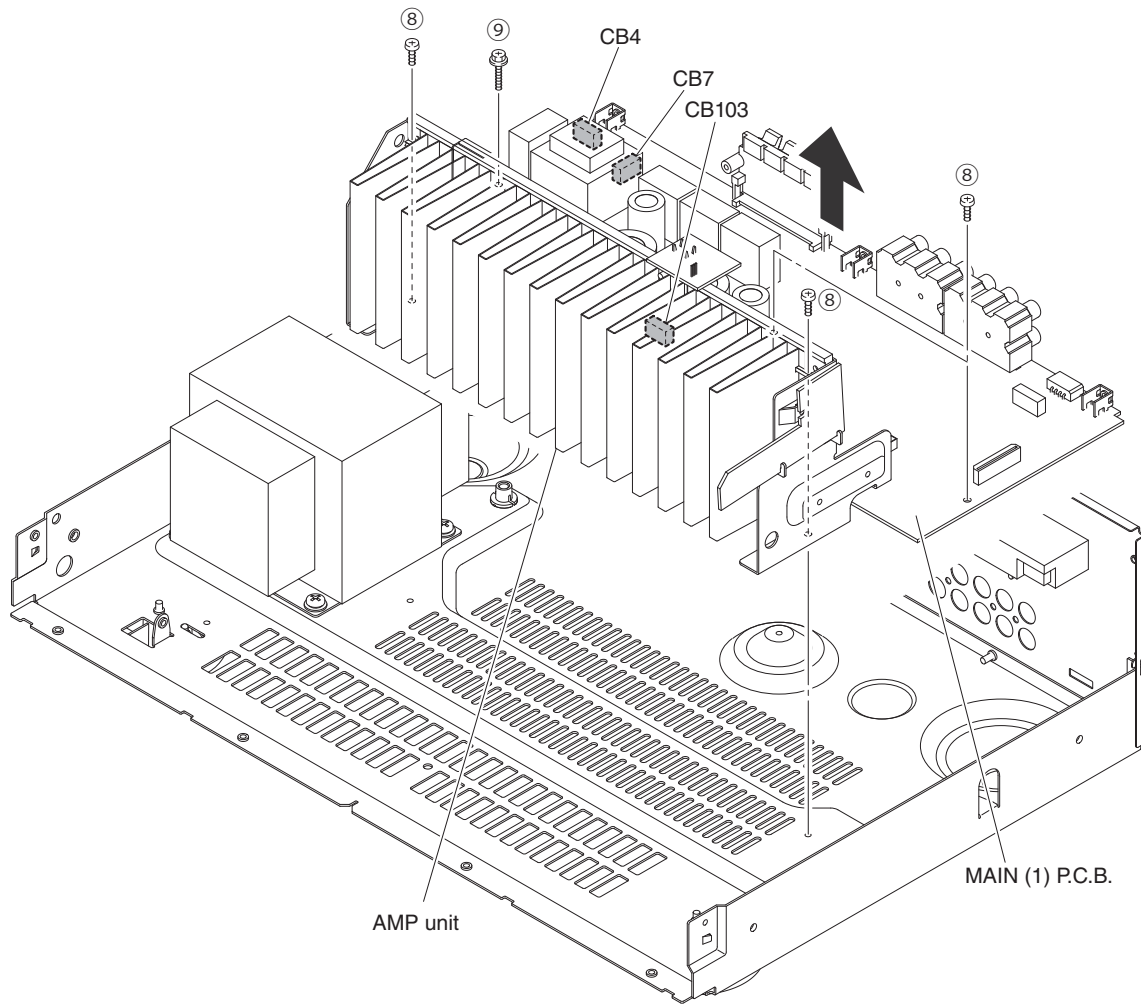

Fig. 2

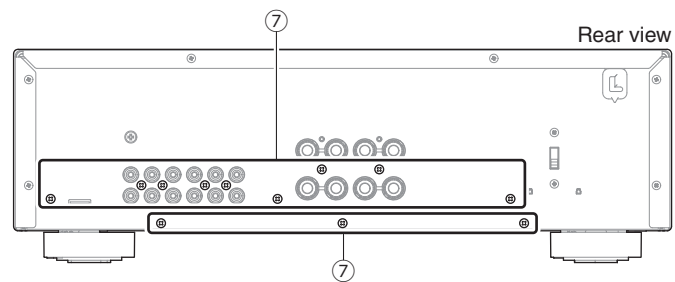
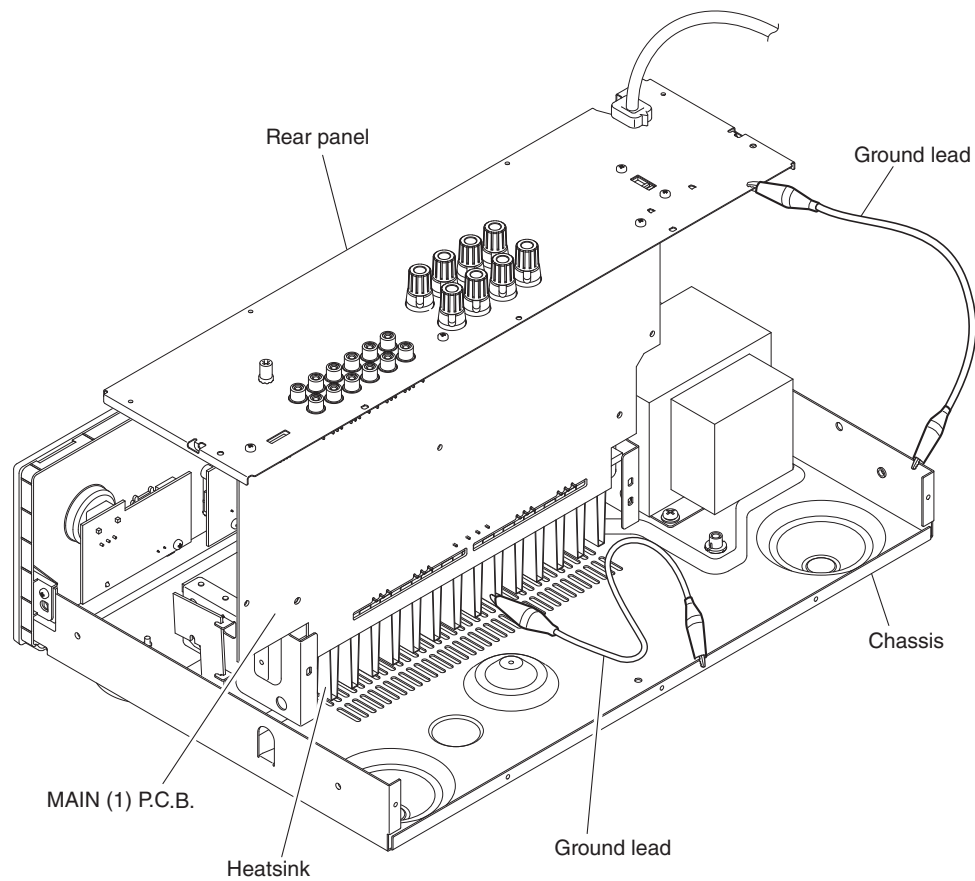

Fig. 3

When checking the MAIN (1) P.C.B.:

- Place the P.C.B.s (with rear panel) upright. (Fig. 4)
- Connect the heatsink and rear panel to the chassis with a ground lead or the like. (Fig. 4)
- Reconnect all cables (connectors) that have been disconnected.
- When connecting the flexible flat cable, be careful with polarity.

**Fig. 4**

■ UPDATING FIRMWARE

When the following parts are replaced, the firmware must be updated to the latest version.

MAIN P.C.B.

Microprocessor: IC203 on FUNCTION (1) P.C.B.

● Confirmation of firmware version and checksum

Before and after updating the firmware, check the firmware version and checksum by using the self-diagnostic function menu.

Start up the self-diagnostic function and select "1. FIRMWARE VERSION/CHECK SUM" menu.

Using the sub-menu, have the firmware version and checksum displayed, and note them down.

(For details, refer to "SELF-DIAGNOSTIC FUNCTION")

- * When the firmware version is different from written one after updating, perform the updating procedure again from the beginning.

● Initializing the back-up IC

After updating the firmware, the back-up IC MUST be initialized by the following procedure to store the setting information properly.

Start up the self-diagnostic function and select "3. FACTORY PRESET" menu.

(For details, refer to "SELF-DIAGNOSTIC FUNCTION")

Select "PRST RSRV", press the "⏻" (Power) key to turn off the power once and turn on the power again. Then the back-up IC is initialized.

● Required Tools

- Firmware downloader program
..... RFP.exe
- Firmware
..... AS_201_xxx.mot
- RS-232C conversion adaptor (Part No.: ZK189200)
- Flexible flat cable
(9 pin 150 mm pitch = 1.25, Part No.: ZD896000)
- USB to Serial converter
(USB type-A to D-sub 9 pin)
- * Recommendation: BUFFALO
(Part No.: BSUSRC0605BS)
FTDI Ltd.
(Part No.: DS-US232R-10)

● Preparation and precautions

- Download the firmware downloader program and the latest firmware from the specified download source to the same folder of the PC.
- Prepare the above specified RS-232C cross cable.
- While writing the firmware, keep the other application software on the PC closed.
It is also recommended to keep the software on the task tray closed as well.

● Connection

- * Disconnect the power cable of this unit from the AC outlet.
- Connect the writing port (CB201 on MAIN (1) P.C.B.) located on the rear panel of this unit to the USB port of the PC with USB to serial converter, RS-232C conversion adaptor and flexible flat cable as shown below. (Fig. 1)

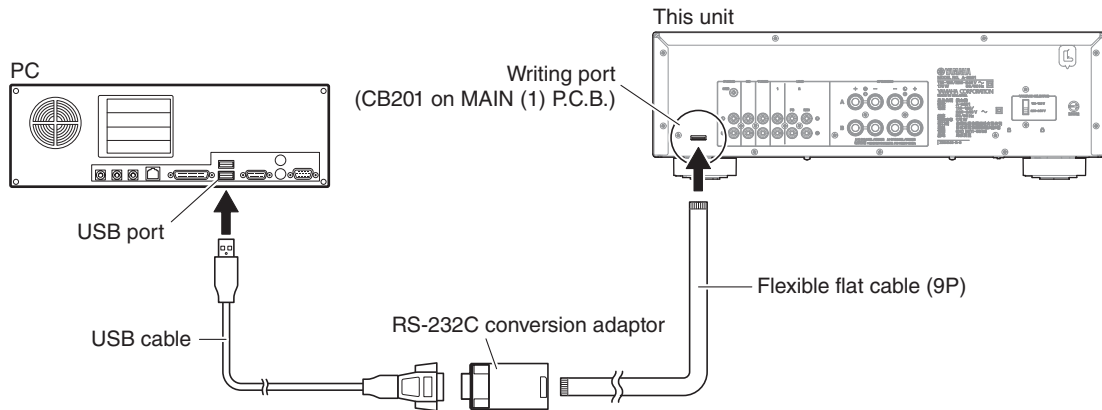

Fig. 1

● Operation procedure

1. Connect the power cable of this unit to the AC outlet.
The power to this unit is supplied and the microprocessor is in the writing mode.
2. Start up RFP.exe.
The screen appears as shown below. (Fig. 2)
3. Select the Basic mode and click [Next]. (Fig. 2)

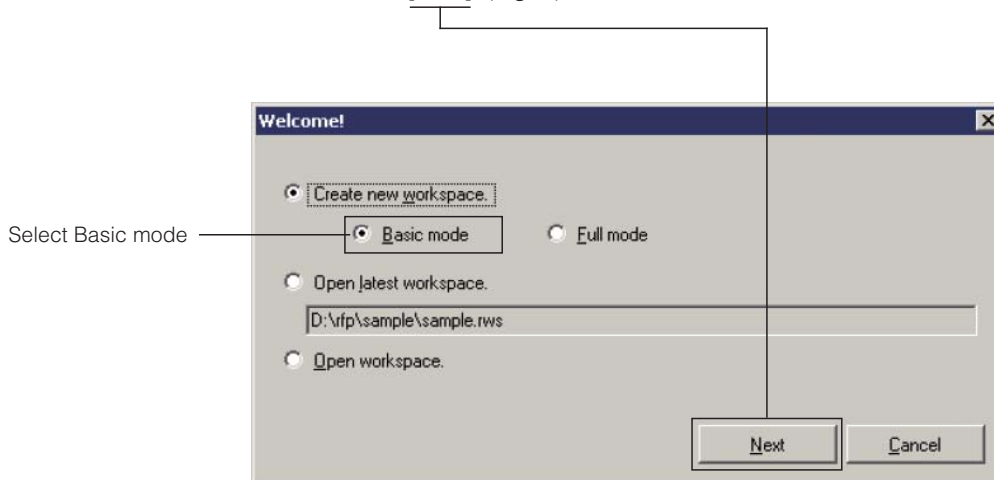

Fig. 2

4. Select the type of the microprocessor and make the workspace. (Fig. 3)
 - Microcontroller: RL78
 - Using Target Microcontroller: RL78/G13, R5F100JE
 - Workspace Name: Any name
 - Project Name: Any name
 - Folder: Any place
 - * Click [Browse...] and specify the place where the workspace is made. (Fig.3)
5. Click [Next]. (Fig. 3)

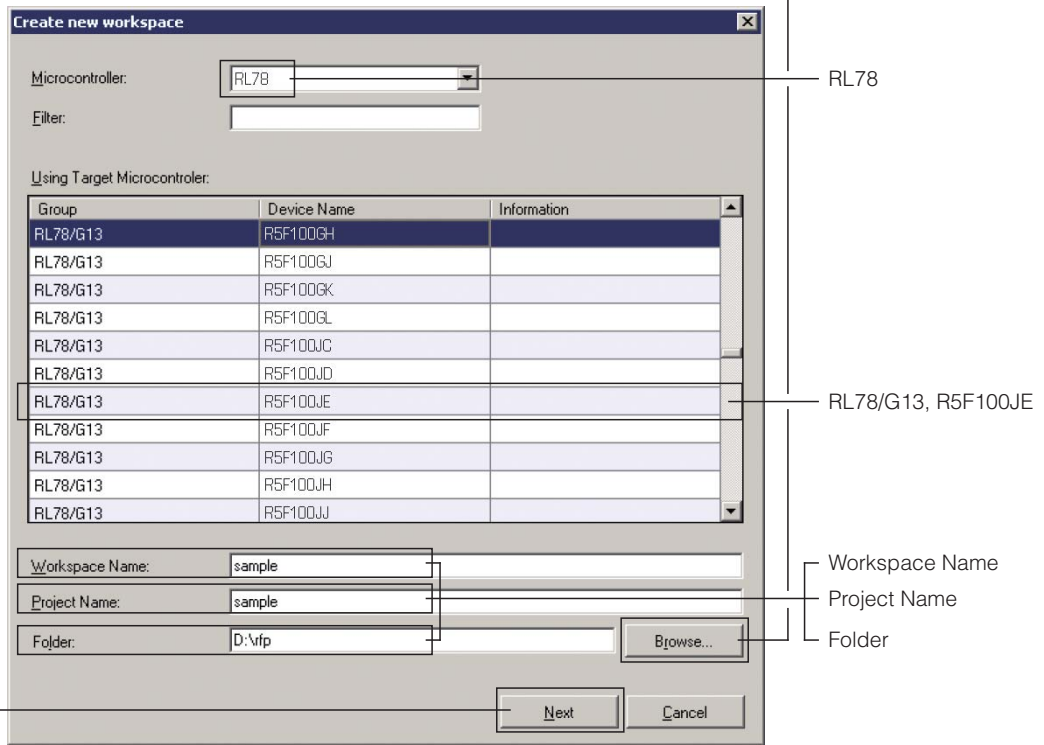

Fig. 3

A-S201

6. Select COMx with the Tool and click [Next]. (Fig. 4)
 - * Do not proceed to other settings until clicking [Next] is completed. (Fig. 4)

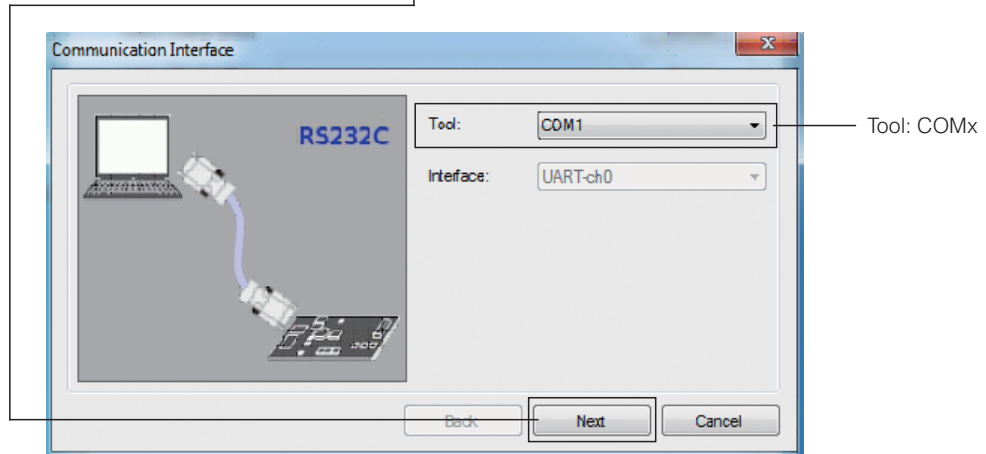

Fig. 4

7. Make the port (COMx) setting. (Fig. 5)
 - a. Access the device manager. (Fig. 5)
 - * To access the device manager, click [Start], [Control panel], [System], [Hardware] and [Device manager] in this order.
 - b. Right click the communication port (COMx) of the port (COM and LPT) to open the property. (Fig. 5)
 - * COMx: Enter the port number of the PC to which the USB to serial converter is connected in place of "x".
 - c. Using the port setting function, set the Bit/second to "115200". (Fig. 5)
8. Click [OK]. (Fig. 5)

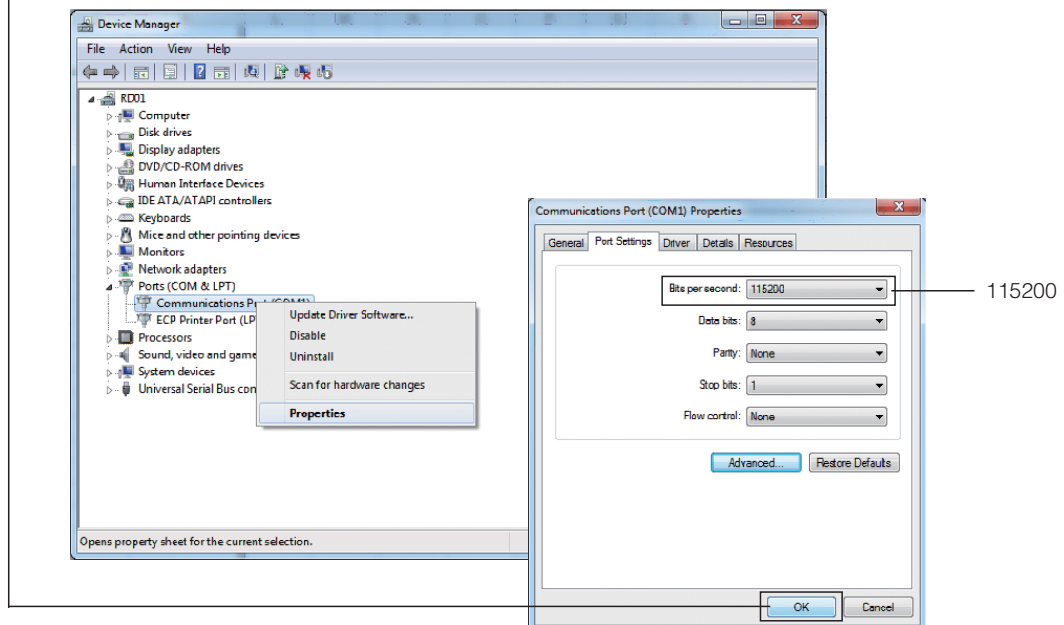
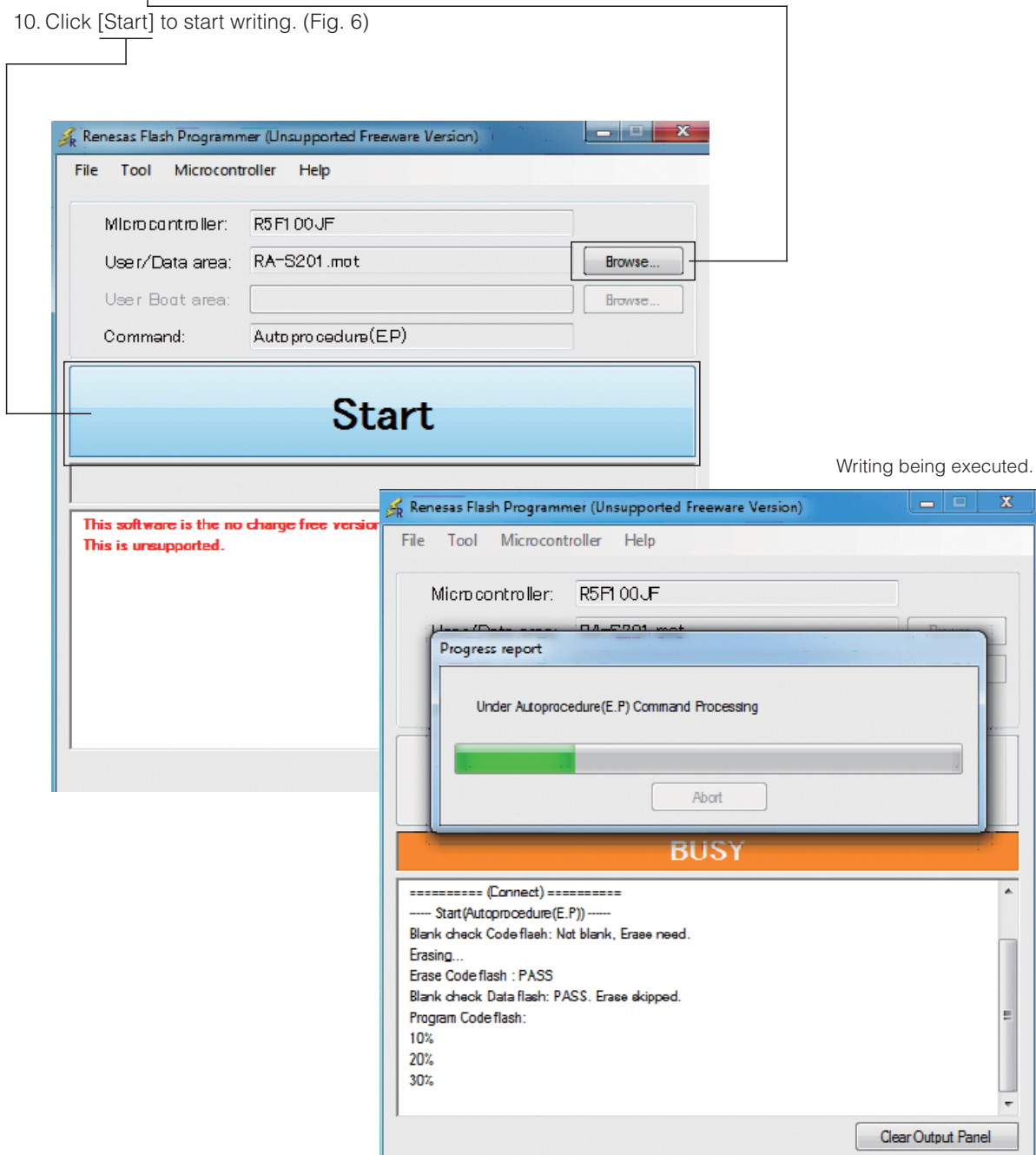

Fig. 5

9. Click [Browse...] and select the firmware name. (Fig. 6)
10. Click [Start] to start writing. (Fig. 6)



Writing being executed.

Fig. 6

11. When writing of the firmware is completed, the screen appears as shown below. (Fig. 7)
12. Click [X] to end RFP.exe. (Fig. 7)

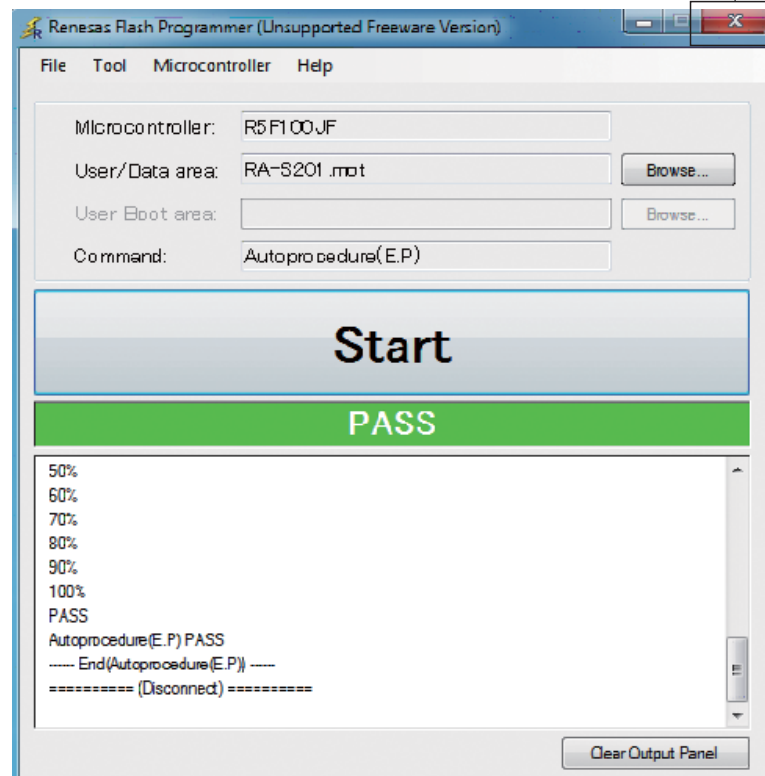

Fig. 7

13. Disconnect the power cable of this unit from the AC outlet.
14. Remove the RS-232C conversion adaptor and flexible flat cable from the writing port (CB201 on MAIN (1) P.C.B.) of this unit.
15. Connect the power cable of this unit to the AC outlet, start up the self-diagnostic function and check that the firmware version and checksum are the same as written ones. (For details, refer to "Confirmation of firmware version and checksum")

■ SELF-DIAGNOSTIC FUNCTION

This unit has self-diagnostic functions that are intended for inspection, measurement and location of faulty point.

There are 6 main menu items, each of which has sub-menu items.

Listed in the table below are main menu items and sub-menu items.

Note: Some of the menu items listed below may not apply to the models covered in this service manual.

No.	Main menu	No.	Sub-menu
1	FIRMWARE VERSION/CHECK SUM	1	FIRMWARE VERSION
		2	FIRMWARE CHECKSUM
		3	MODEL/DESTINATION
2	DISPLAY CHECK	1	VFD CHECK
		2	ALL SEGMENT OFF
		3	ALL SEGMENT ON
3	FACTORY RESET	1	PRESET INHIBIT
		2	PRESET RESERVE
4	AD DATA CHECK	1	PS
		2	DC
		3	TA
		4	DESTINATION
		5	KEY
5	PROTECTION HISTORY	1	HISTORY 1
		2	HISTORY 2
		3	HISTORY 3
		4	HISTORY 4
6	POWER OFF FACTOR HISTORY	1	LAST
		2	HISTORY 1
		3	HISTORY 2
		4	HISTORY 3
		5	HISTORY 4

● Starting Self-Diagnostic Function

While pressing the “BASS +” and “SPEAKERS A” keys, press the “⏻” (Power) key to turn on the power, and release those 2 keys.

The self-diagnostic function mode is activated.

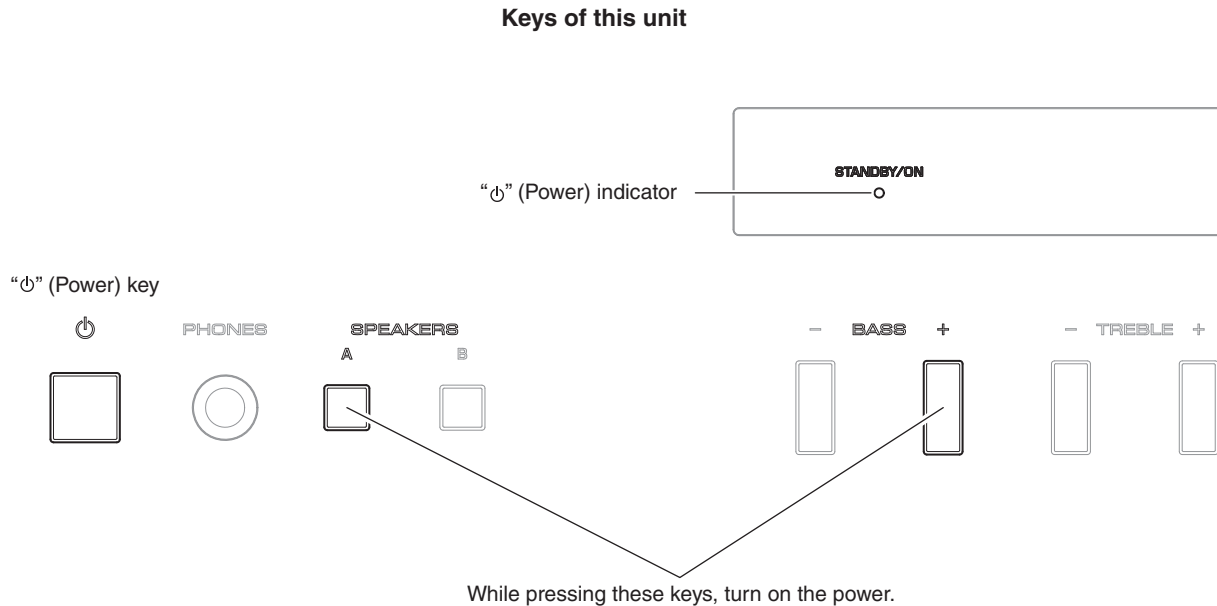

● Starting Self-Diagnostic Function in the protection cancel mode

If the protection function works and causes hindrance to troubleshooting, cancel the protection function by the procedure below, and it will be possible to enter the self-diagnostic function mode. (The protection functions other than the excess current detect function will be disabled.)

While pressing the “BASS +” and “SPEAKERS A” keys, press the “⏻” (Power) key to turn on the power and keep pressing those 2 keys and “⏻” (Power) key for 3 seconds or longer.

The self-diagnostic function mode is activated with the protection functions disabled.

In this mode, the “SLEEP” segment of the FL display flashes to indicate that the mode is self-diagnostic function mode with the protection functions disabled.

CAUTION!

Using this unit with the protection function disabled may cause further damage to this unit. Use special care for this point when using this mode.

● Canceling Self-Diagnostic Function

1. Before canceling self-diagnostic function, execute setting for “3. FACTORY PRESET” menu. (Memory initialization inhibited or Memory initialized).
 - * In order to keep the user memory preserved, be sure to select PRESET INHIBIT (Memory initialization inhibited).
2. Press the “⏻” (Power) key to turn off the power.

● Display provided when Self-Diagnostic Function started

The display is as described below depending on the situation when the power to this unit is turned off.

1. When the power is turned off by usual operation:

“NO PROTECT” is displayed. Then “1. VERSION/SUM” is displayed in a few seconds.

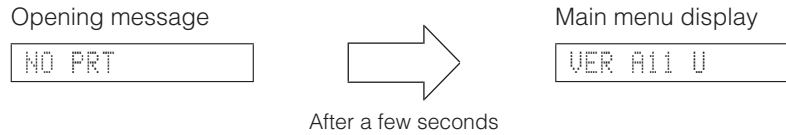

2. When the protection function worked to turn off the power:

The information of protection function which worked at that time is displayed. Then “1. VERSION/SUM” is displayed in a few seconds.

Note: At that time if you restart the self-diagnostic function after turning off the power once, “NO PROTECT” will be displayed. That is because that situation is equal to “1. When the power is turned off by usual operation:”.

However history of the protection function is stored in memory as backup data. For details, refer to “5. PROTECTION HISTORY” menu.

2-1. When there is a history of protection function due to excess current.

I PRT

Display: The Power indicator is flashing.

Cause: An excessive current flowed through the power amplifier.

Supplementary information: As current of the power amplifier is detected, the abnormal channel can be identified by checking the current detect transistor.

Turning on the power without correcting the abnormality will cause the protection function to work immediately and the power supply will instantly be shut off.

Notes:

- Applying the power to this unit without correcting the abnormality can be dangerous and cause additional circuit damage. To avoid this, if protection function due to excess current works 1 time, the power will not turn on even when the “” (Power) key is pressed. In order to turn on the power again, disconnect the power cable of this unit from the AC outlet once and then reconnect it again.
- The output transistors in each amplifier channel should be checked for damage before applying power to this unit.
- Amplifier current should be monitored by measuring DC voltage across the emitter resistors for each channel.

2-2. When the protection function worked due to abnormal DC output.

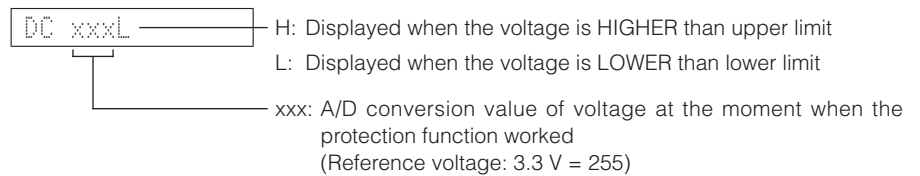

Cause: DC output of the power amplifier is abnormal.

Supplementary information: The protection function worked due to a DC voltage appearing at the speaker terminal. A cause could be a defect in the amplifier.

Turning on the power without correcting the abnormality will cause the protection function to work in 3 seconds and the power supply will be shut off.

2-3. When the protection function worked due to abnormal voltage in the power supply section.

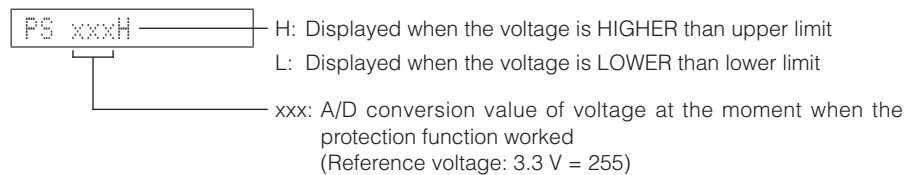

Cause: The voltage in the power supply section is abnormal.

Supplementary information: The protection function worked due to a defect or overload in the power supply.

Turning on the power without correcting the abnormality will cause the protection function to work in 1 seconds and the power supply will be shut off.

Notes:

- Applying the power to this unit without correcting the abnormality can be dangerous and cause additional circuit damage. To avoid this, if "PS" and "DC" protection function works 3 times consecutively, the power will not turn on even when the "⏻" (Power) key is pressed. In order to turn on the power again, disconnect the power cable of this unit from the AC outlet once and then reconnect it again.
- The output transistors in each amplifier channel should be checked for damage before applying power to this unit.
- Amplifier current should be monitored by measuring DC voltage across the emitter resistors for each channel.

2-4. When the protection function worked due to excessive heatsink temperature.

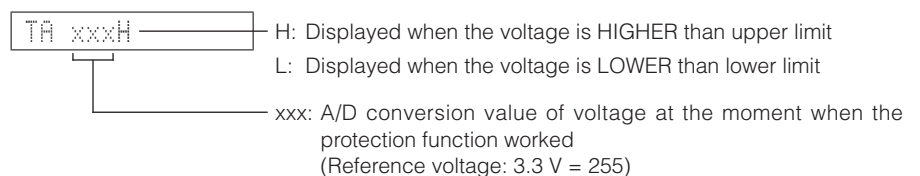

Cause: The temperature of the heatsink is excessive.

Supplementary information: The protection function worked due to the temperature limit being exceeded. Causes could be poor ventilation or a defect related to the thermal sensor.

Turning on the power without correcting the abnormality will cause the protection function to work in 1 seconds and the power supply will be shut off.

● History of protection function

When the protection function has worked, its history is stored in memory as backup data.

Even if no abnormality is noted while servicing the unit, an abnormality which has occurred previously can be defined as long as the backup data has been stored.

For details, refer to “5. PROTECTION HISTORY” menu.

● Operation procedure of Main menu and Sub-menu

There are 6 main menu items, each of which has sub-menu items.

Main menu selection

Select the main menu using “INPUT ►” (forward) and “INPUT ◀” (reverse) keys.

Sub-menu selection

Select the sub-menu using “TREBLE +” (forward) and “TREBLE -” (reverse) keys.

Keys of this unit

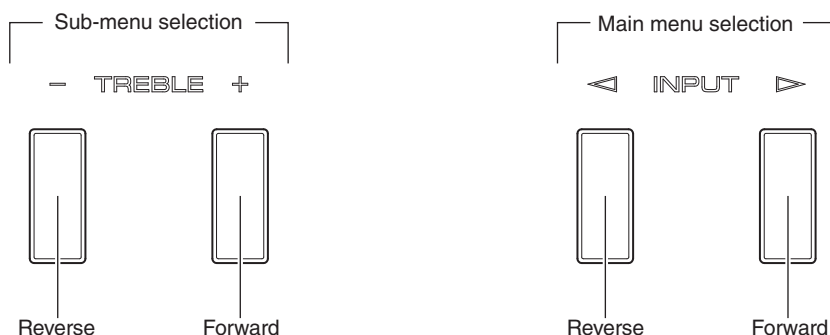

● Functions in Self-Diagnostic Function mode

In addition to the self-diagnostic function menu items, functions listed below are available.

- Power ON/OFF
- Master volume
- SPEAKERS A ON/OFF
- PURE DIRECT ON/OFF

* Functions related to the tuner and the set menu are not available.

● Initial settings when Self-Diagnostic Function started

The following initial settings are used when self-diagnostic function is started.

When self-diagnostic function is canceled, these settings are restored to those before starting self-diagnostic function.

- Master volume: 60
- Input: CD
- SPEAKER: SPEAKERS A on

● Details of Self-Diagnostic Function menu

1. FIRMWARE VERSION/CHECK SUM

This menu is used to display the firmware version and checksum.

The checksum is obtained by adding the data at every 8-bit and expressing the result as a 4-digit hexadecimal notation.

* Numeric values in the figure are given as reference only.

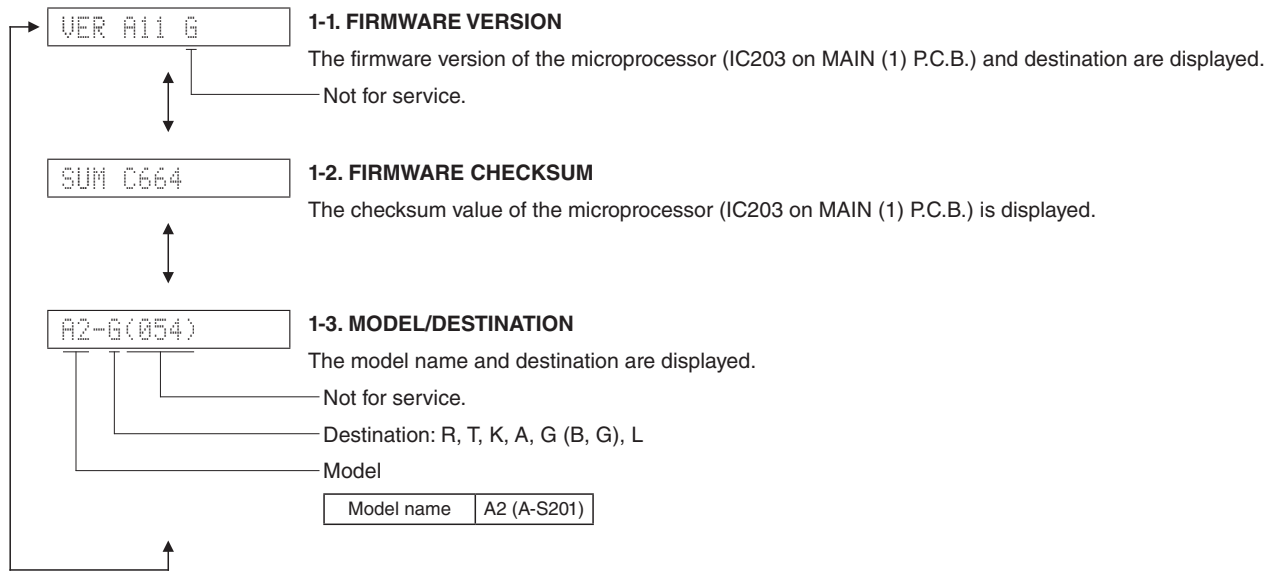

2. DISPLAY CHECK

This menu is used to check operation of the FL display.
Using the sub-menu, the display varies as shown below.

FL display

2-1. INITIAL DISPLAY



2-2. ALL SEGMENT OFF



2-3. ALL SEGMENT ON

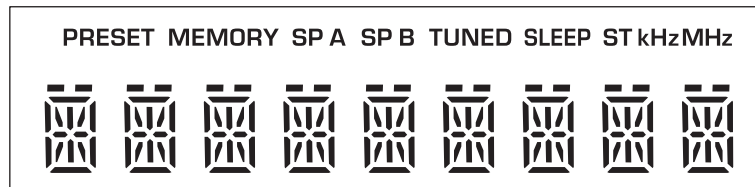

* After check, change to next sub-menu at once.

Segment conditions of the FL driver and the FL tube are checked by turning ON and OFF all segments.

3. FACTORY PRESET

This menu is used to reserve/inhibit initialization of the back-up IC.

PRST INHI

3-1. PRESET INHIBIT (Initialization inhibited)

Initialization of the back-up IC is not executed. Select this sub-menu to protect the values set by the user.



PRST RSRV

3-2. PRESET RESERVED (Initialization reserved)

Initialization of the back-up IC is reserved. (Actual initialization is executed when the power is turned on next.)

To reset to the original factory settings or to reset the backup IC, select this sub-menu and press the “⏻” (Power) key to turn off the power.

CAUTION: Before setting to the PRESET RESERVED, write down the existing preset memory content of the tuner. (This is because setting to the PRESET RESERVED will cause the user memory content to be erased.)

4. AD DATA CHECK

This menu is used to display the A/D conversion value of the microprocessor which detects panel keys and protection functions by using the sub-menu.

When “4-5. KEY” sub-menu is selected, keys become inoperable due to detection of the values of all keys. However, it is possible to advance to the next menu by pressing the “▲” (forward) key or “▼” (reverse) key on the remote control.

* Numeric values in the figure are given as reference only.

4-1. PS

Power supply voltage (PS) protection detection.

The voltage at 44 pin (PRPS) of IC203 is displayed.

Normal value: 113 to 175

(Reference voltage: 3.3 V = 255)

* If PS becomes out of the normal value range, the protection function works to turn off the power.

PS 145

4-2. DC

Power amplifier DC (DC voltage) output is detected.

The voltage at 42 pin (PRD) of IC203 is displayed.

Normal value: 27 to 136

(Reference voltage: 3.3 V = 255)

* If DC becomes out of the normal value range, the protection function works to turn off the power.

DC 089

4-3. TA

Temperature of the heatsink (TA) is detected.
 The voltage at 43 pin (THM) of IC203 is displayed.
 Normal value: 15 to 134 (R, K, A, B, G models)
 15 to 130 (T, L models)
 (Reference voltage: 3.3 V = 255)

* If TA becomes out of the normal value range, the protection function works to turn off the power.

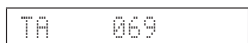

4-4. DESTINATION

Destination of this unit is detected.
 The voltage at 45 pin (DEST) of IC203 is displayed.
 (Reference voltage: 3.3 V = 255)

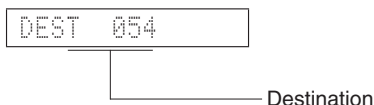

Destination	R	T	K	A	G (B, G)	L
A/D value (3.3 V = 255)	162 – 178	092 – 102	103 – 114	031 – 047	048 – 059	115 – 123

4-5. KEY

Panel key is detected.
 KEY0: The voltage at 40 pin (KEY0) of IC203 is displayed.
 KEY1: The voltage at 41 pin (KEY1) of IC203 is displayed.
 When the A/D conversion value of the panel key becomes out of the specified range, normal operation will not be available.
 In that case, check the constant of voltage dividing resistor, solder condition, etc. Refer to table.
 * When “4-5. KEY” menu is selected, keys become inoperable due to detection of the values of all keys.
 However, it is possible to advance to the next menu by pressing the “▲” (forward) key or “▼” (reverse) key on the remote control.
 (Reference voltage: 3.3 V = 255)

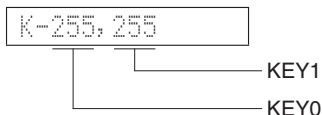

Display	KEY0
000 – 011	INPUT ►
012 – 032	INPUT ◀
033 – 054	TREBLE +
055 – 079	TREBLE –
080 – 107	BASS +
108 – 134	BASS –
135 – 160	PURE DIRECT

Display	KEY1
161 – 187	SPEAKER A
188 – 214	SPEAKER B

5. PROTECTION HISTORY

This menu is used to display the history of protection function.

When the "SPEAKERS B" key is pressed, the protection history being displayed will be cleared.

* Numeric values in the figure are given as reference only.

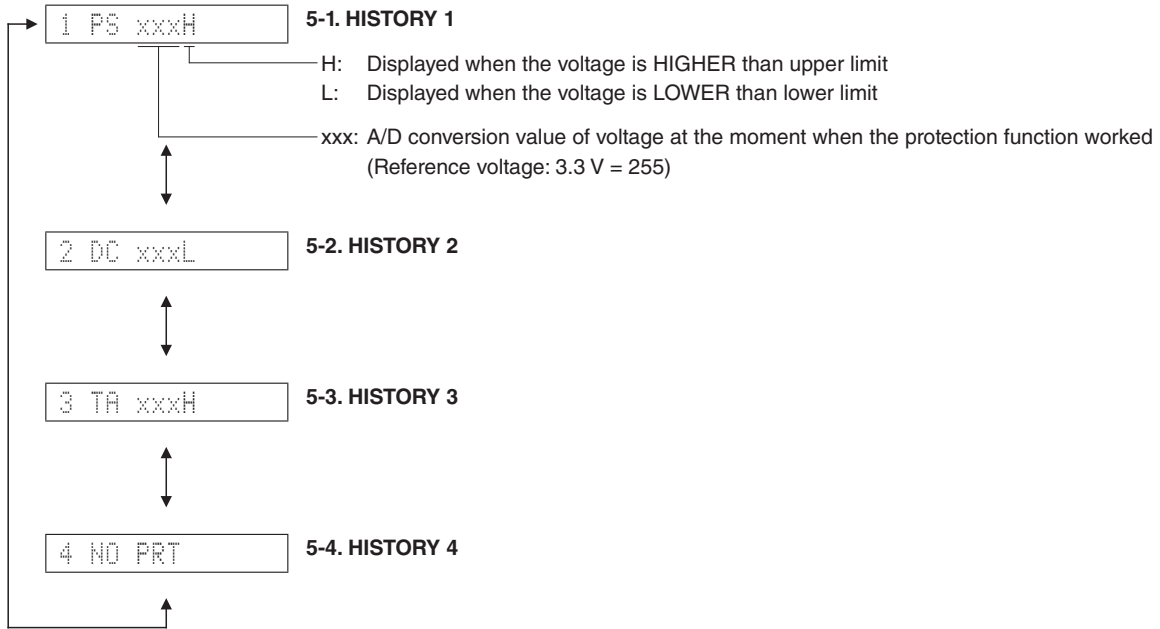

6. POWER OFF FACTOR HISTORY

This menu is used to display the history of power off factor.

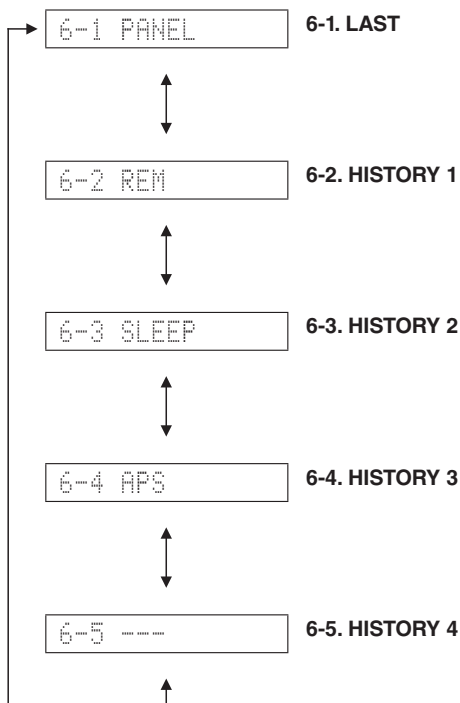

Power off factor are as follows.

6-x PANEL	"⏻" (Power) key of this unit
6-x REM	"⏻" (Power) key on the remote control
6-x SLEEP	SLEEP timer
6-x APS	POWER MANAGEMENT (Automatic Power Down) timer
6-x PRT	Protection
6-x AC	AC OFF
6-x ---	No history

■ DISPLAY DATA

● V501 : HNV-10SS61 (MAIN P.C.B.)

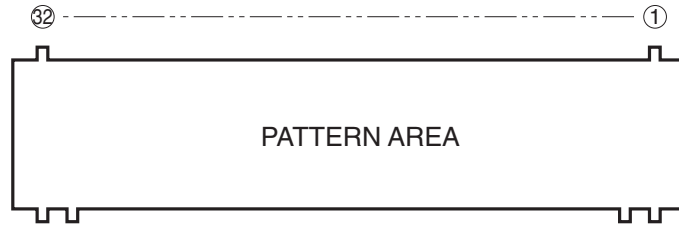

● PIN CONNECTION

Pin No.	32	31	30	29	28	27	26	25	24	23	22	21
Connection	F2	F2	NP	1G	2G	3G	4G	5G	6G	7G	8G	9G

Pin No.	20	19	18	17	16	15	14	13	12	11	10	9	8	7	6	5	4	3	2	1
Connection	10G	P16	P15	P14	P13	P12	P11	P10	P9	P8	P7	P6	P5	P4	P3	P2	P1	NP	F1	F1

Note : 1) Fn Filament pin 2) nG Grid pin 3) Pn Anode pin 4) NP No pin

● GRID ASSIGNMENT

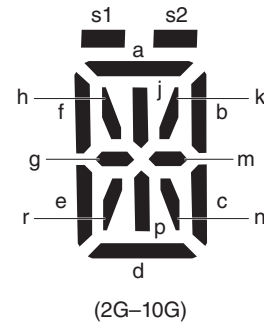
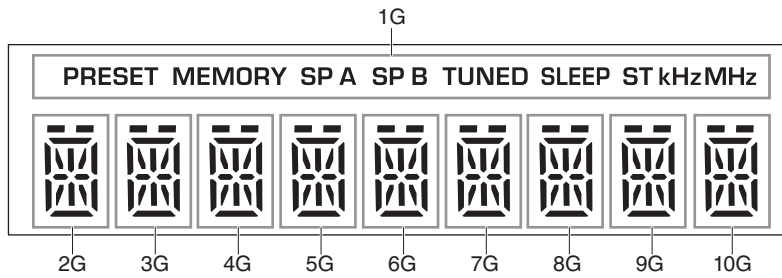

● ANODE CONNECTION

	1G	2G - 10G		1G	2G - 10G
P1	MHz	s2	P9	PRESET	g
P2	kHz	s1	P10		m
P3	ST	a	P11		c
P4	SLEEP	b	P12		e
P5	TUNED	f	P13		r
P6	SP A	h	P14		p
P7	SP B	j	P15		n
P8	MEMORY	k	P16		d

IC DATA

IC203: R5F100JEAFA (MAIN (1) P.C.B.)

Microprocessor

* No replacement part available.

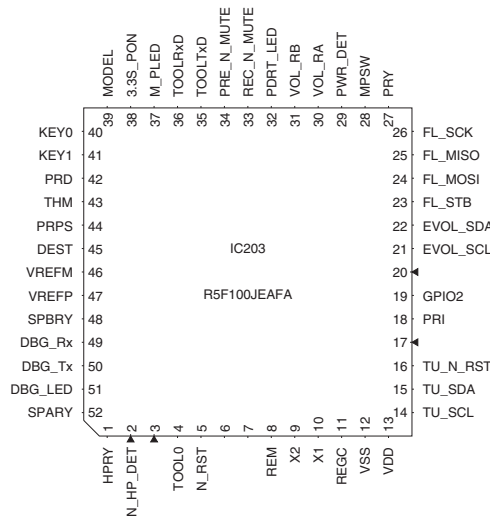
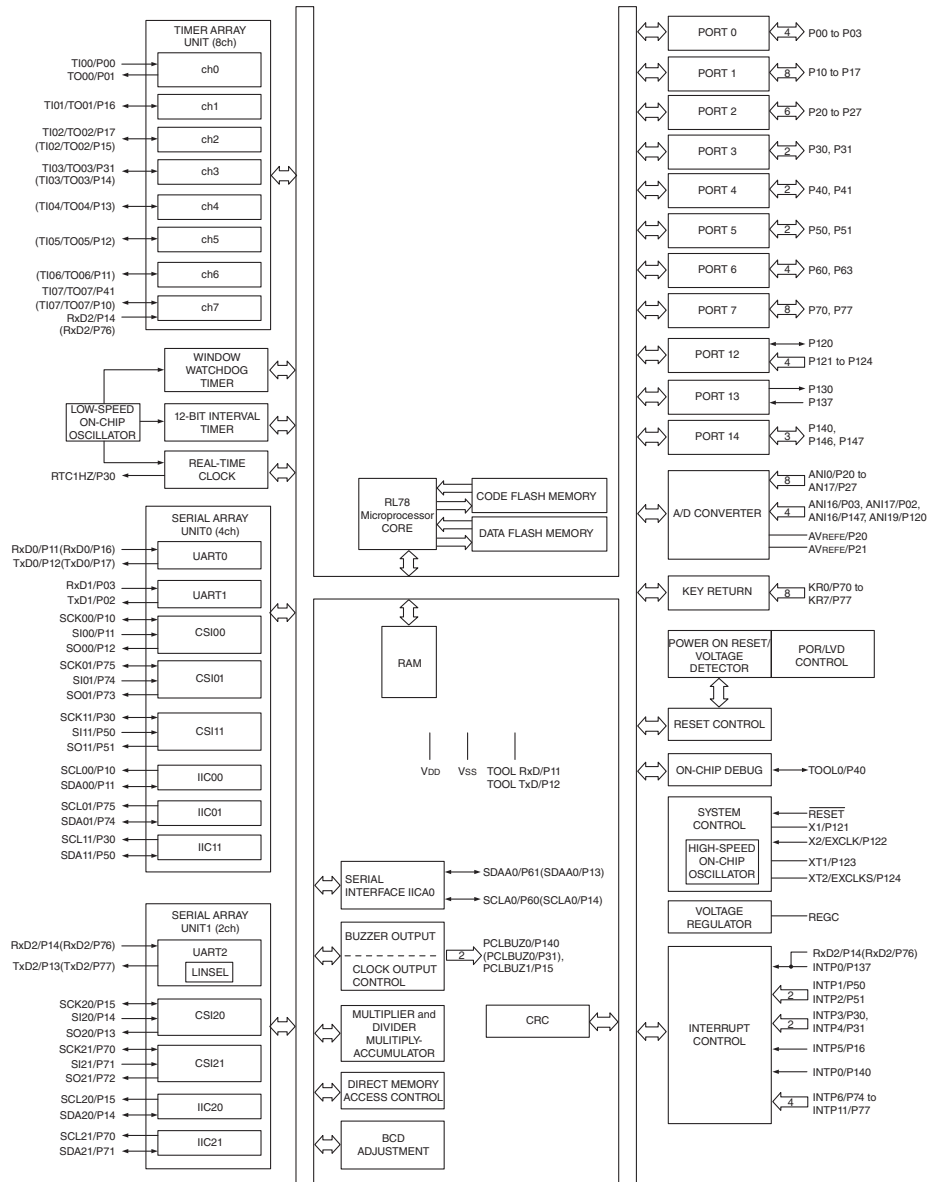

A-S201

Pin No.	Port Name	Function Name	I/O		Detail of Function
			Related Power Supply OFF	ON	
1	P140/PCLBUZ0/INTP6	HPRY	O	O	HP relay (HIGH = ON)
2	P120/ANI19	(Vacant)			Detection of HP insertion (LOW = inserted) (HP_N_DET spare)
3	P41/TI07/TO07	(Vacant)			
4	P40/TOOL0	TOOL0	I	I	For E1 debugging
5	RESET	N_RST	I	I	For debugging
6	P124/XT2/EXCLKS	(Vacant)	I	I	
7	P123/XT1	(Vacant)	I	I	
8	P137/INTP0	REM	I	IRQ	IR light receiving unit
9	P122/X2/EXCLK	(Vacant)	I	I	Ceramic lock (X2 spare)
10	P121/X1	(Vacant)	I	I	Ceramic lock (X1 spare)
11	REGC	REGC	I	I	Regulator (Connected to VSS via capacitor)
12	VSS	VSS	I	I	GND
13	VDD	VDD	I	I	+5V power supply
14	P60/SCLA0	TU_SCL	I	I2C	-----
15	P61/SDAA0	TU_SDA	I	I2C	-----
16	P62	TU_N_RST	O	O	-----
17	P63	(Vacant)	O	O	
18	P31/TI03/TO03/INTP4/(PCLBUZ0)	PRI	I	I	I protection detection
19	P77/KR7/INTP11/(TXD2)	GPIO2	I	IRQ	-----
20	P76/KR6/INTP10/(RXD2)	(Vacant)	O	O	
21	P75/KR5/INTP9/SCK01/SCL01	EVOL_SCL	I	I2C	VOL IC
22	P74/KR4/INTP8/SI01/SDA01	EVOL_SDA	I	I2C	VOL IC
23	P73/KR3/SO01	FL_STB	O	O	FL driver
24	P72/KR2/SO21	FL_MOSI	O	SPI	FL driver
25	P71/KR1/SI21/SDA21	FL_MISO	O	SPI	FL driver (spare)
26	P70/KR0/SCK21/SCL21	FL_SCK	O	SPI	FL driver
27	P30/INTP3/RTC1HZ/SCK11/SCL11	PRY	O	O	Power relay control
28	P50/INTP1/SI11/SDA11	MPSW	I	IRQ	Main power SW (Tact SW)
29	P51/INTP2/SO11	PWR_DET	I	IRQ	Power detect (LOW = AC-OFF)
30	P17/TI02/TO02/(TXD0)	VOL_RA	I	I	Volume encoder clockwise
31	P16/TI01/TO01/INTP5/(RXD0)	VOL_RB	I	I	Volume encoder counterclockwise
32	P15/PCLBUZ1/SCK20/SCL20/(TI02)/(TO02)	PDRT_LED	O	O	PURE DIRECT Led (LOW = OFF)
33	P14/RxD2/SI20/SDA20/(SCLA0)/(TI03)/(TO03)	REC_N_MUTE	O	O	REC OUT mute (LOW = MUTE ON)
34	P13/TxD2/SO20/(SDAA0)/(TI04)/(TO04)	PRE_N_MUTE	O	O	PRE OUT mute (LOW = MUTE ON)
35	P12/SO00/TxD0/TOOLTxD/(TI05)/(TO05)	(Vacant)	O	O	Flash writing (TOOL TxD spare)
36	P11/SI00/RxD0/TOOLRxD/SDA00/(TI06)/(TO06)	(Vacant)	O	O	Flash writing (TOOL RxD spare)
37	P10/SCK00/SCL00/(TI07)/(TO07)	PLED	O	O	Power LED (HIGH = ON)
38	P146	3.3S_PON	O	O	Power supply (VFD driver power supply)
39	P147/ANI18	MODEL	I	I	Model discrimination
40	P27/ANI7	KEY0	I	I	INPUT (◀, ▶) / BASS (+, -) / TREBLE (+, -) / PURE DIRECT
41	P26/ANI6	KEY1	I	I	SPEAKERS (A, B)
42	P25/ANI5	PRD	I	I	DC protection detection (AMP DC / Voltage detection)
43	P24/ANI4	THM	I	I	Temperature protection detection (Thermal detection)
44	P23/ANI3	PRPS	I	I	PS protection detection (Power supply / Power voltage detection)
45	P22/ANI2	DEST	I	I	Destination discrimination
46	P21/ANI1/AVREFM	VREFM	I	I	Analog reference voltage minus
47	P20/ANI0/AVREFP	VREFP	I	I	Analog reference voltage plus
48	P130	SPBRY	O	O	Speaker B relay ON/OFF (HIGH = ON)
49	P03/ANI16/RxD1	DEB_RX	I	—	For debugging
50	P02/ANI17/TxD1	DEB_TX	O	—	For debugging
51	P01/TO00	DEB_LED	I/O	I/O	For debugging
52	P00/TI00	SPARY	O	O	Speaker A relay ON/OFF (HIGH = ON)

Key detection for A/D port

Key input (A/D) pull-up resistance 10 k-ohms

	0 Ω	+ 1.0 k Ω	+ 1.0 k Ω	+ 1.5 k Ω	+ 2.2 k Ω	+ 3.3 k Ω	+ 4.7 k Ω
Detected voltage value at 40 pin	0 – 0.22 V	0.23 – 0.64 V	0.65 – 1.06 V	1.07 – 1.55 V	1.56 – 2.09 V	2.10 – 2.62 V	2.63 – 3.12 V
A/D value (3.3 V = 255)	000 – 011	012 – 032	033 – 054	055 – 079	080 – 107	108 – 134	135 – 160
KEY0	INPUT ▶	INPUT ◀	TREBLE +	TREBLE –	BASS +	BASS –	PURE DIRECT

	+ 7.5 k Ω	+ 15 k Ω
Detected voltage value at 41 pin	2.08 – 2.41 V	2.42 – 2.77 V
A/D value (3.3 V = 255)	161 – 187	188 – 214
KEY1	SPEAKER A	SPEAKER B

Destination detection for AD port

Pull-up resistance 10 k-ohms

R280 on MAIN (1) P.C.B.	20 k Ω	6.2 k Ω	7.5 k Ω	1.8 k Ω	2.7 k Ω	9.1 k Ω
Detected voltage value at 45 pin	2.1 – 2.3 V	1.19 – 1.32 V	1.33 – 1.48 V	0.4 – 0.61 V	0.62 – 0.76 V	1.49 – 1.59 V
A/D value (3.3 V = 255)	162 – 178	092 – 102	103 – 114	031 – 047	048 – 059	115 – 123
Destination	R	T	K	A	G (B, G)	L

■ BLOCK DIAGRAM

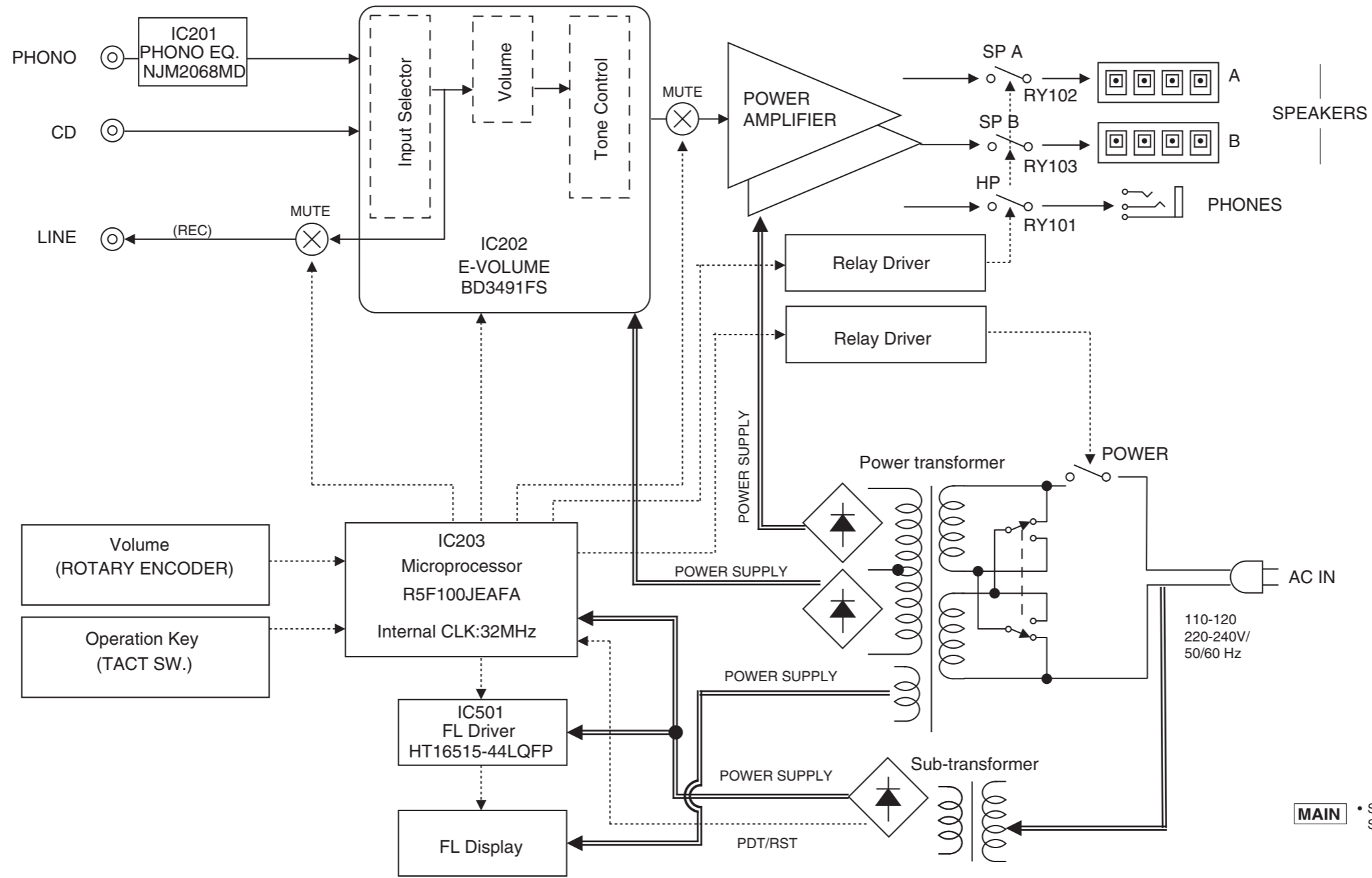

MAIN • See page 41 → SCHEMATIC DIAGRAM

1 ■ **WIRING DIAGRAM**
 • **OVERALL ASSEMBLY**

2

3

4

5

6

7

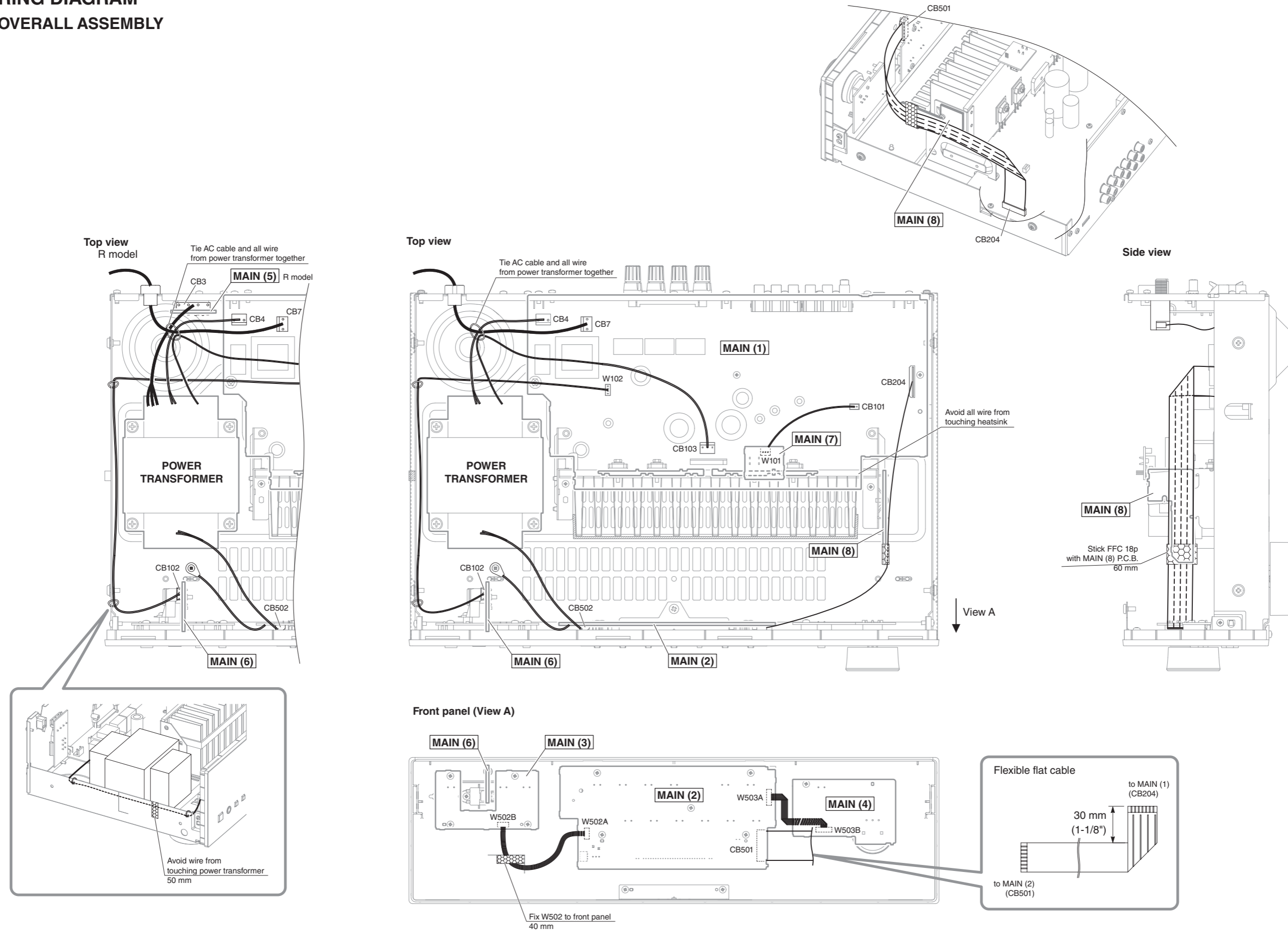

PRINTED CIRCUIT BOARDS

MAIN (1) (Side A)

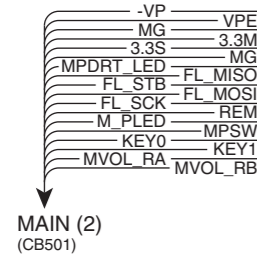
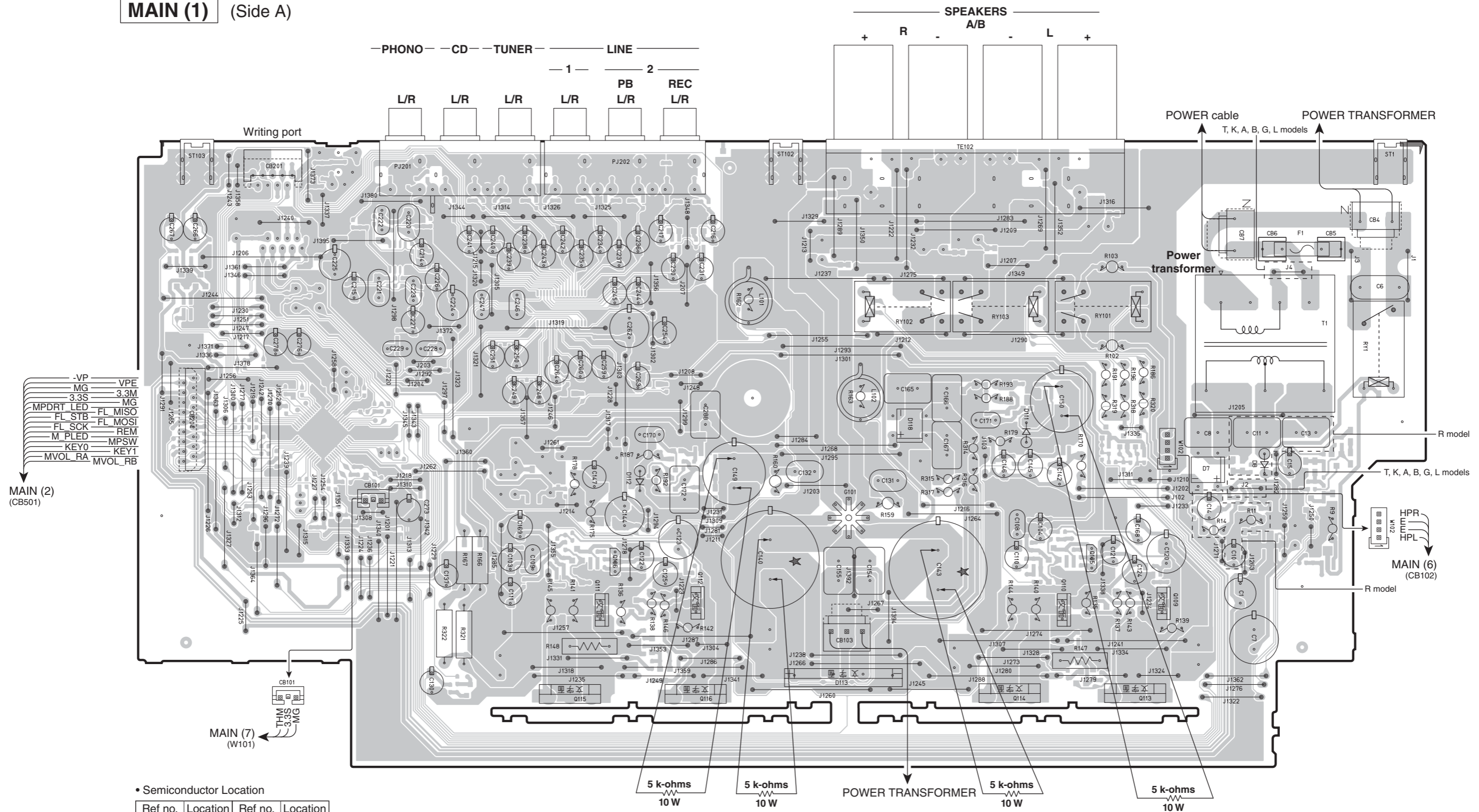

MAIN (7) (W101)

• Semiconductor Location

Ref no.	Location	Ref no.	Location
D7	I4	Q109	H5
D8	I4	Q110	H5
D111	H4	Q111	E5
D112	D4	Q112	F5
D113	F6	Q113	H6
D118	G4	Q114	G6
Q105	H5	Q115	E6
Q106	E5	Q116	F6

Safety measures

- Some internal parts in this product contain high voltages and are dangerous. Be sure to take safety measures during servicing, such as wearing insulating gloves.
- Note that the capacitors indicated below are dangerous even after the power is turned off because an electric charge remains and a high voltage continues to exist there. Before starting any repair work, connect a discharging resistor (5 k-ohms/10 W) to the terminals of each capacitor indicated below to discharge electricity. The time required for discharging is about 30 seconds per each. C140, C143, C149, C150 on MAIN (1) P.C.B.

1
2
3
4
5
6
7

MAIN (1) (Side B)

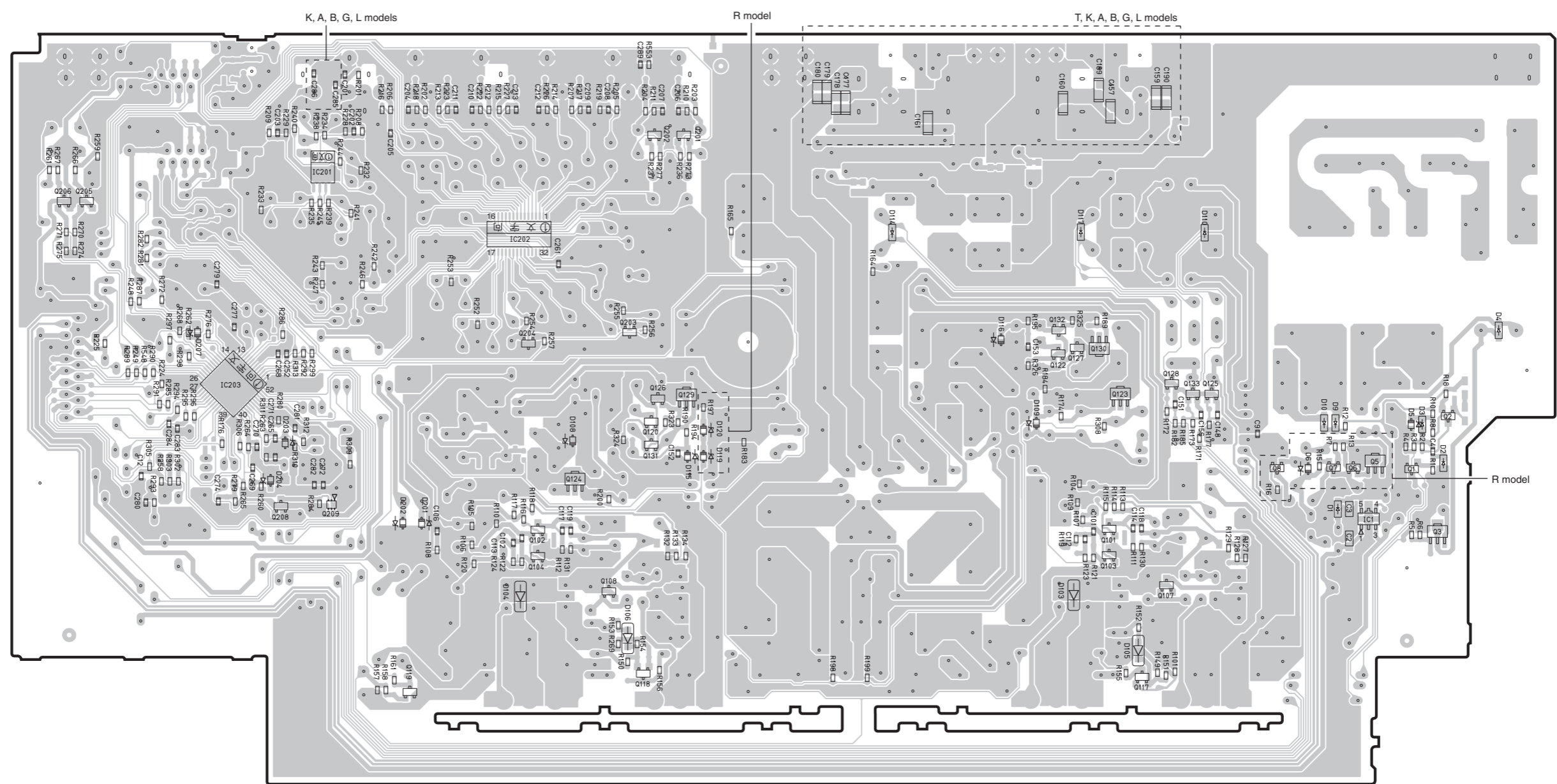

• Semiconductor Location

Ref no.	Location	Ref no.	Location	Ref no.	Location	Ref no.	Location	Ref no.	Location	Ref no.	Location	Ref no.	Location	Ref no.	Location	Ref no.	Location
D1	H5	D103	G5	D115	E4	D204	C4	Q3	I5	Q107	G5	Q124	D4	Q132	G4	Q208	C5
D2	I4	D104	D5	D116	G4	D207	B4	Q5	I4	Q108	E5	Q125	H4	Q133	H4	Q209	C5
D3	I4	D105	G5	D117	G3	IC1	I5	Q6	H4	Q117	G6	Q126	E4	Q201	E3		
D4	I4	D106	E5	D119	E4	IC201	C3	Q7	H4	Q118	E5	Q127	G4	Q202	E3		
D5	I4	D108	D4	D120	E4	IC202	D3	Q8	H4	Q119	D6	Q128	H4	Q203	E4		
D6	H4	D109	G4	D201	D5	IC203	C4	Q101	G5	Q120	E4	Q129	E4	Q204	D4		
D9	H4	D110	H3	D202	D5	Q1	I4	Q102	D5	Q122	G4	Q130	G4	Q205	B3		
D10	H4	D114	F3	D203	C4	Q2	I4	Q103	G5	Q123	G4	Q131	E4	Q206	B3		

MAIN (2) (Side A)

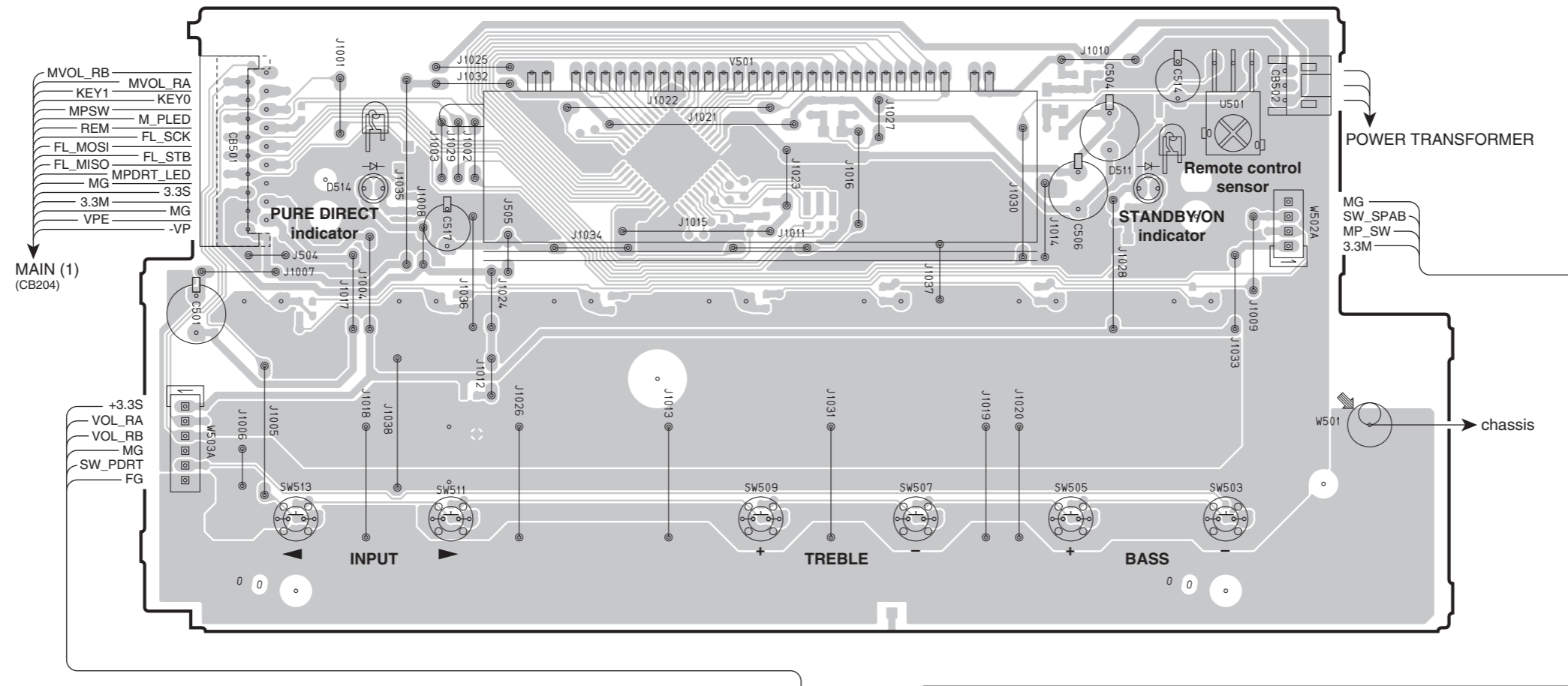

• Semiconductor Location

Ref no.	Location
D511	G2
D514	D2

MAIN (3) (Side A)

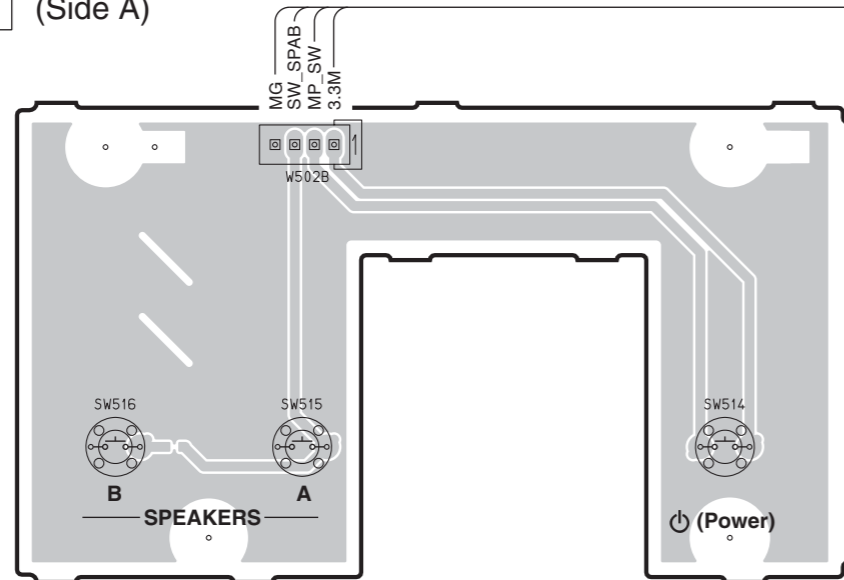

MAIN (4) (Side A)

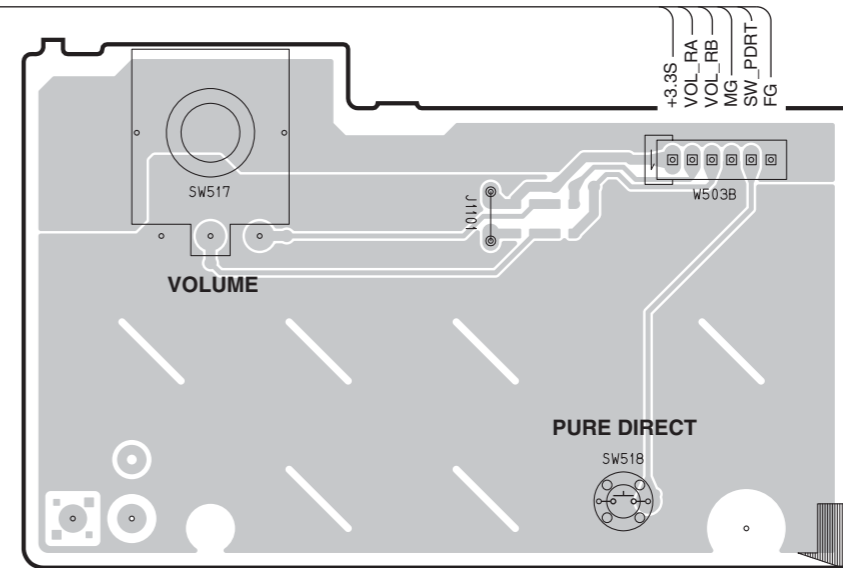

1

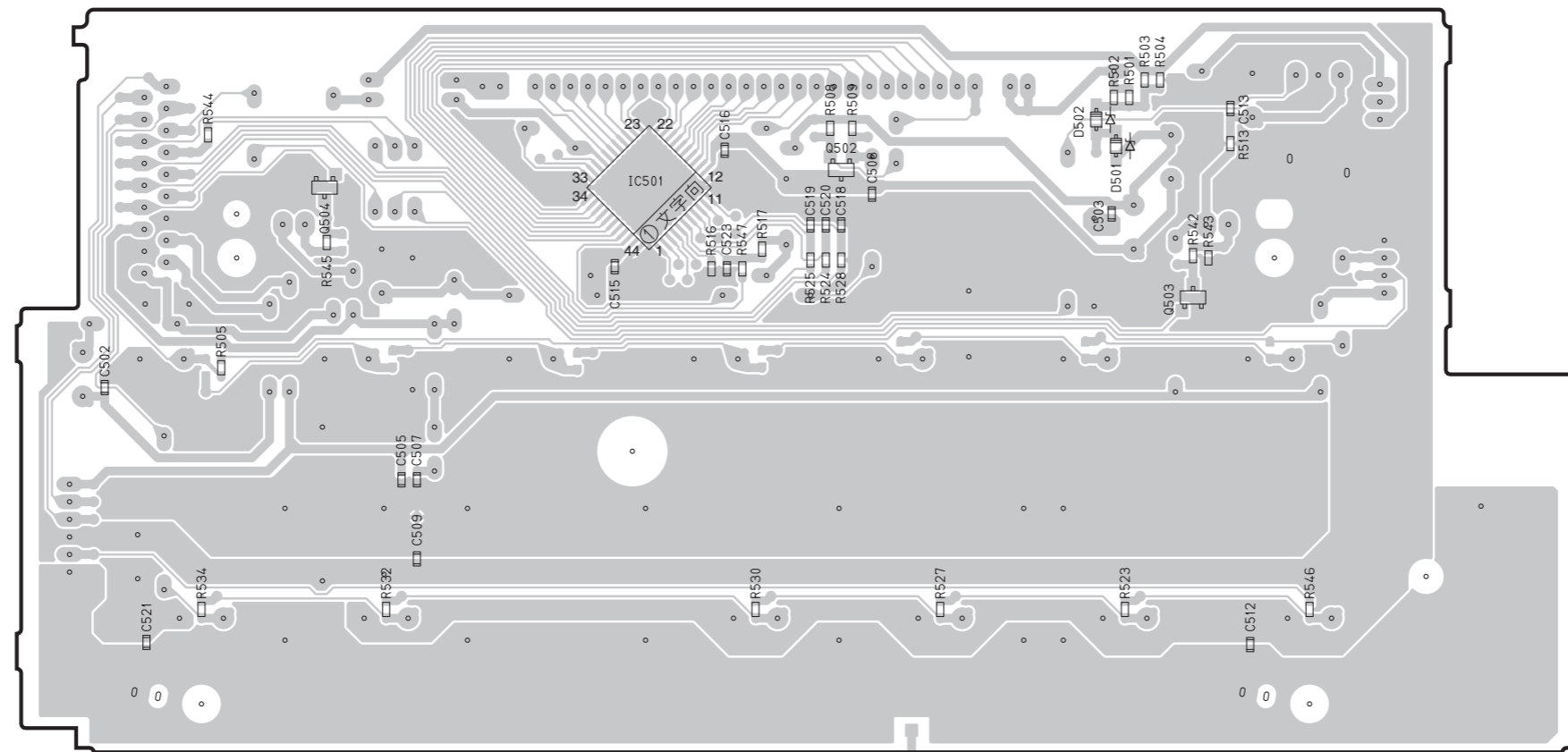
MAIN (2) (Side B)

• Semiconductor Location

Ref no.	Location
D501	F2
D502	F2
IC501	E2
Q502	E2
Q503	G3
Q504	C2

4

5

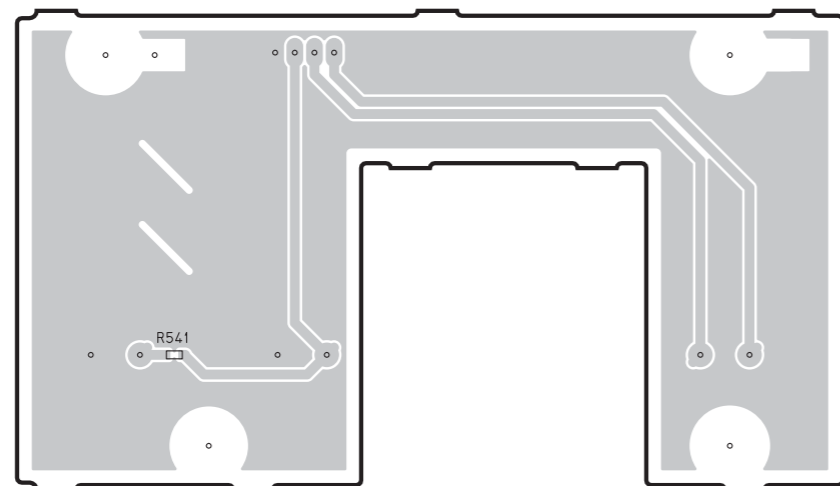
MAIN (3) (Side B)

6

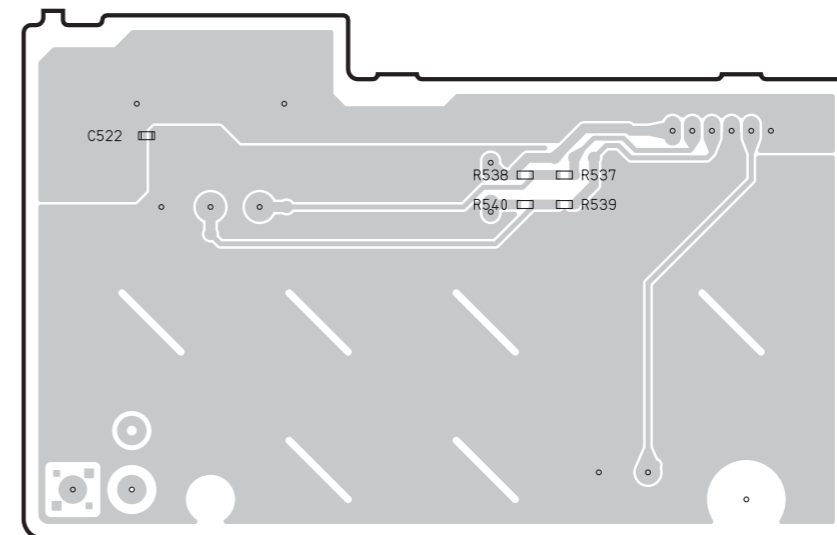
MAIN (4) (Side B)

7

MAIN (5) (Side A)
R model

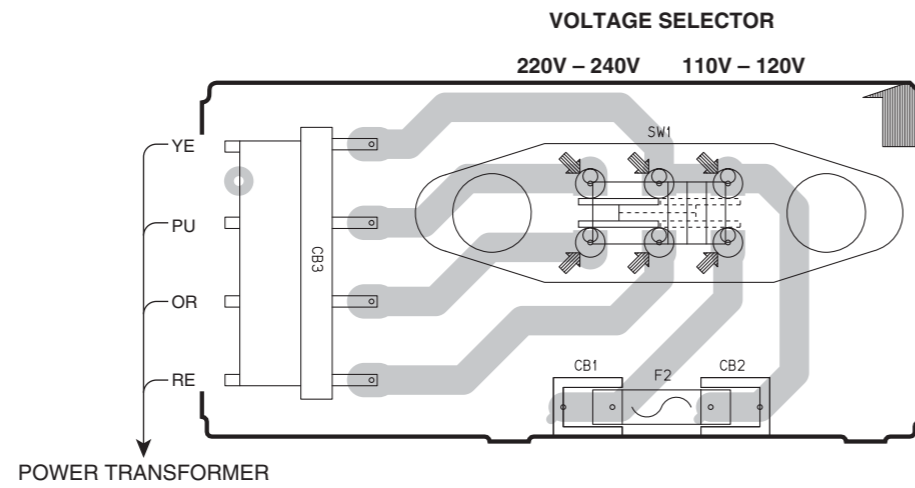

MAIN (6) (Side A)

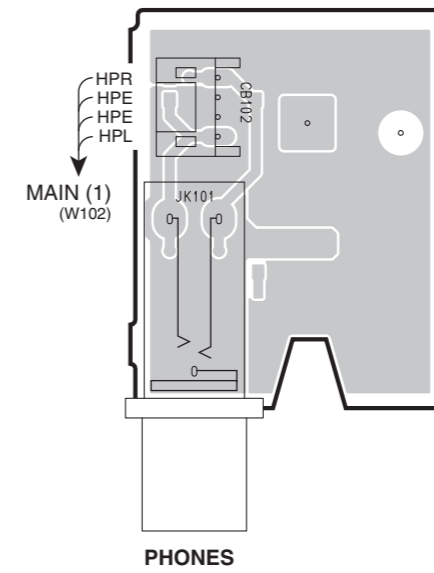

MAIN (7) (Side A)

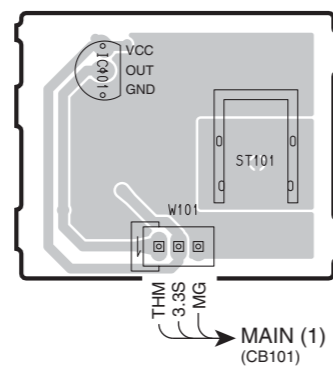

• Semiconductor Location

Ref no.	Location
IC101	D5

MAIN (8) (Side A)

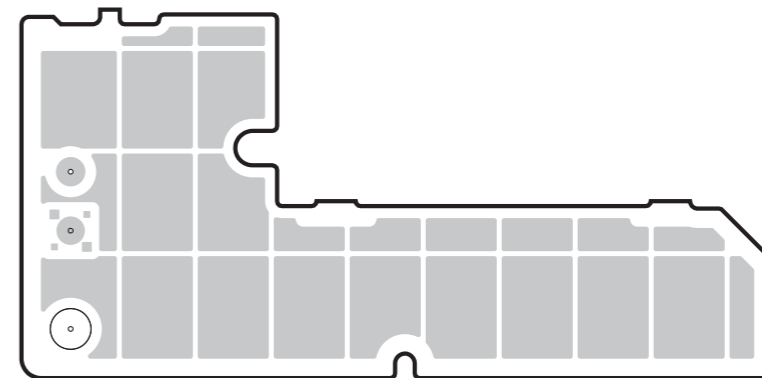

1

MAIN (5) (Side B)
R model

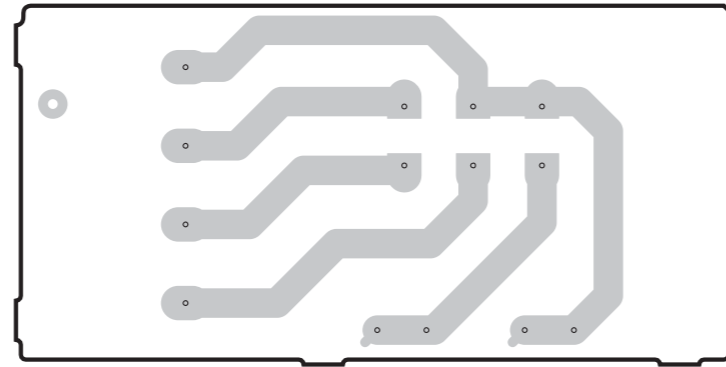

2

MAIN (6) (Side B)

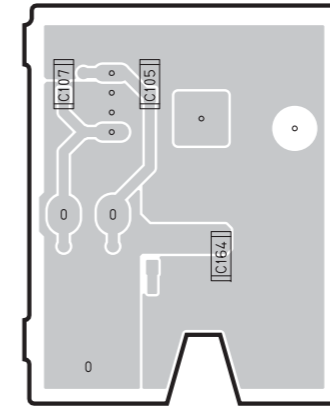

3

4

MAIN (7) (Side B)

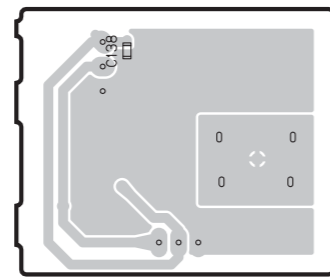

5

MAIN (8) (Side B)

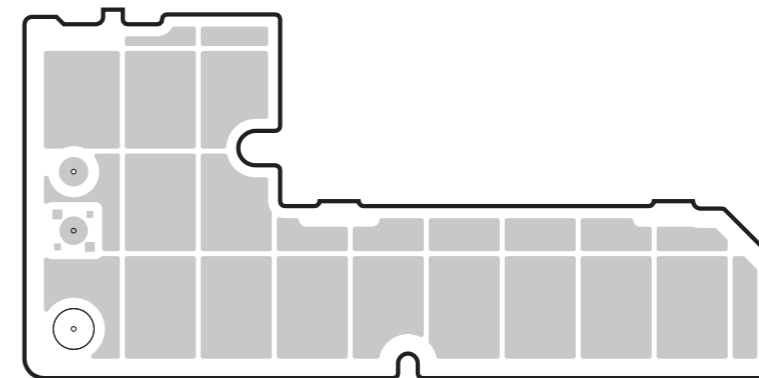

6

7

PIN CONNECTION DIAGRAMS

• ICs

<p>BD3491FS-E2</p>	<p>HT16515-44LQFP</p>	<p>LM61CIZ</p>	<p>NJM2068MD-TE2</p>	<p>R5F100JEAFA</p>	<p>R1190H033B-T1-FE</p>
--------------------	-----------------------	----------------	----------------------	--------------------	-------------------------

• Diodes

<p>1N4003S</p>	<p>1SS355VMTE-17</p>	<p>BAV103</p>	<p>D5SBA60 5A 600V</p>	<p>DB105</p>	<p>UDZV2.4B UDZV4.7B UDZV5.6B UDZV6.2B UDZV9.1B UDZV12B UDZV15B UDZV24B UDZV27B UDZV36B</p>
----------------	----------------------	---------------	------------------------	--------------	---

• Transistors

<p>2N5401S-RTK</p>	<p>2N5551S-RTK 2SA1037K</p>	<p>2SA1037AK R,S 2SA1514K R,S 2SC3906K 2SD2704 K</p>	<p>2SC2412K</p>	<p>2STC4468</p>	<p>3LN01C-TB-E</p>	<p>DTC114EKA</p>
<p>KTA1661-Y-RTF/P KTA1664-Y-RTF/P KTC4373 -Y-RTF/P KTC4376-Y-RTF/P</p>	<p>KTC3206Y-ATP</p>	<p>KTB631K-Y-U/PH KTD600K-Y-U/PH</p>	<p>MCH6336-TL-E</p>			

SCHEMATIC DIAGRAM MAIN

Safety measures

- Some internal parts in this product contain high voltages and are dangerous. Be sure to take safety measures during servicing, such as wearing insulating gloves.
- Note that the capacitors indicated below are dangerous even after the power is turned off because an electric charge remains and a high voltage continues to exist there. Before starting any repair work, connect a discharging resistor (5 k-ohms/10 W) to the terminals of each capacitor indicated below to discharge electricity. The time required for discharging is about 30 seconds per each.

C140, C143, C149, C150 on MAIN (1) P.C.B.

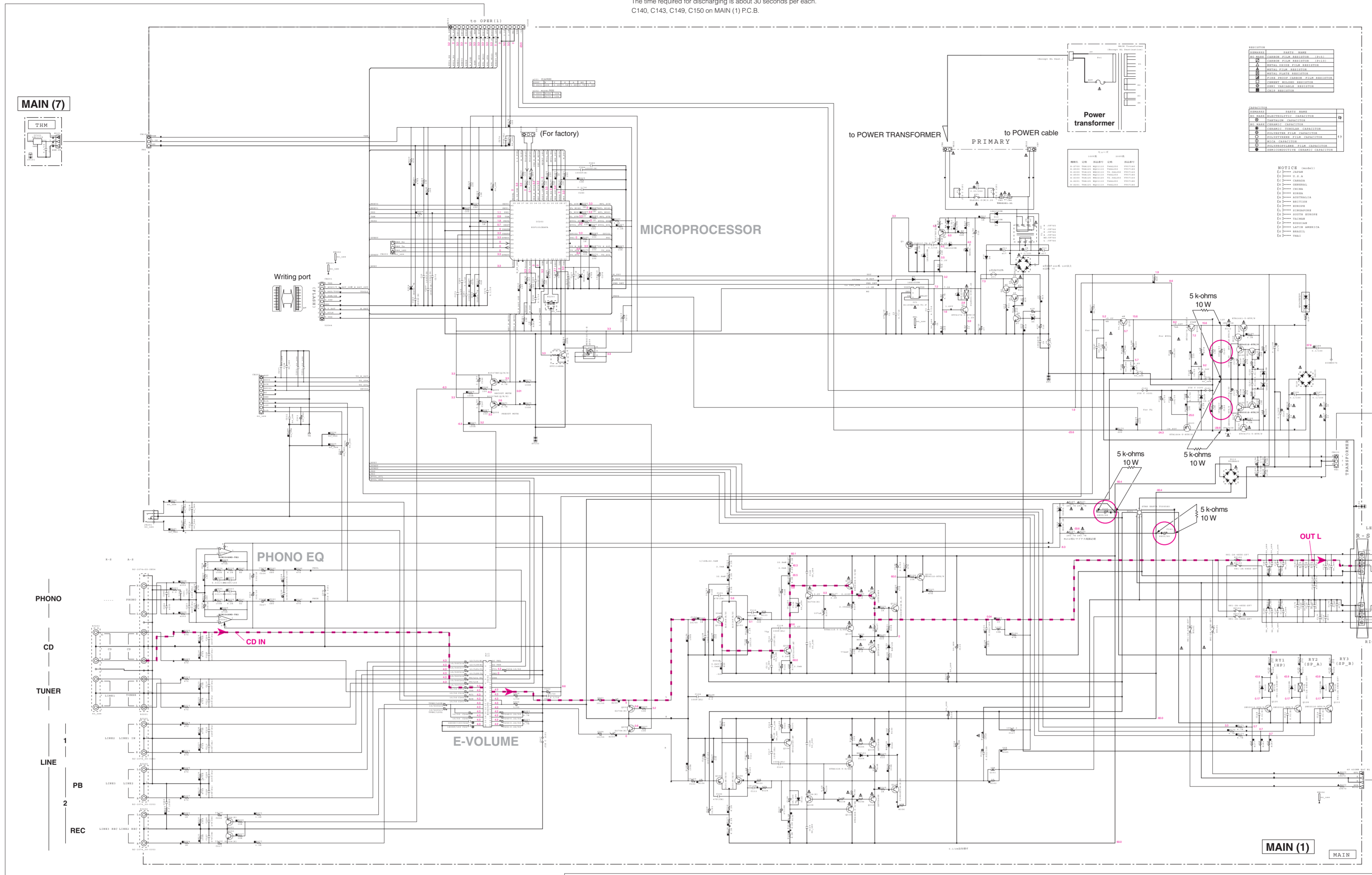

PRESCRIPTION PART LIST

REF.	QTY	SYMBOL	DESCRIPTION	MANUFACTURER
100	1	R101	RESISTOR	DAIICHI
101	1	R102	RESISTOR	DAIICHI
102	1	R103	RESISTOR	DAIICHI
103	1	R104	RESISTOR	DAIICHI
104	1	R105	RESISTOR	DAIICHI
105	1	R106	RESISTOR	DAIICHI
106	1	R107	RESISTOR	DAIICHI
107	1	R108	RESISTOR	DAIICHI
108	1	R109	RESISTOR	DAIICHI
109	1	R110	RESISTOR	DAIICHI
110	1	R111	RESISTOR	DAIICHI
111	1	R112	RESISTOR	DAIICHI
112	1	R113	RESISTOR	DAIICHI
113	1	R114	RESISTOR	DAIICHI
114	1	R115	RESISTOR	DAIICHI
115	1	R116	RESISTOR	DAIICHI
116	1	R117	RESISTOR	DAIICHI
117	1	R118	RESISTOR	DAIICHI
118	1	R119	RESISTOR	DAIICHI
119	1	R120	RESISTOR	DAIICHI
120	1	R121	RESISTOR	DAIICHI
121	1	R122	RESISTOR	DAIICHI
122	1	R123	RESISTOR	DAIICHI
123	1	R124	RESISTOR	DAIICHI
124	1	R125	RESISTOR	DAIICHI
125	1	R126	RESISTOR	DAIICHI
126	1	R127	RESISTOR	DAIICHI
127	1	R128	RESISTOR	DAIICHI
128	1	R129	RESISTOR	DAIICHI
129	1	R130	RESISTOR	DAIICHI
130	1	R131	RESISTOR	DAIICHI
131	1	R132	RESISTOR	DAIICHI
132	1	R133	RESISTOR	DAIICHI
133	1	R134	RESISTOR	DAIICHI
134	1	R135	RESISTOR	DAIICHI
135	1	R136	RESISTOR	DAIICHI
136	1	R137	RESISTOR	DAIICHI
137	1	R138	RESISTOR	DAIICHI
138	1	R139	RESISTOR	DAIICHI
139	1	R140	RESISTOR	DAIICHI
140	1	R141	RESISTOR	DAIICHI
141	1	R142	RESISTOR	DAIICHI
142	1	R143	RESISTOR	DAIICHI
143	1	R144	RESISTOR	DAIICHI
144	1	R145	RESISTOR	DAIICHI
145	1	R146	RESISTOR	DAIICHI
146	1	R147	RESISTOR	DAIICHI
147	1	R148	RESISTOR	DAIICHI
148	1	R149	RESISTOR	DAIICHI
149	1	R150	RESISTOR	DAIICHI
150	1	R151	RESISTOR	DAIICHI
151	1	R152	RESISTOR	DAIICHI
152	1	R153	RESISTOR	DAIICHI
153	1	R154	RESISTOR	DAIICHI
154	1	R155	RESISTOR	DAIICHI
155	1	R156	RESISTOR	DAIICHI
156	1	R157	RESISTOR	DAIICHI
157	1	R158	RESISTOR	DAIICHI
158	1	R159	RESISTOR	DAIICHI
159	1	R160	RESISTOR	DAIICHI
160	1	R161	RESISTOR	DAIICHI
161	1	R162	RESISTOR	DAIICHI
162	1	R163	RESISTOR	DAIICHI
163	1	R164	RESISTOR	DAIICHI
164	1	R165	RESISTOR	DAIICHI
165	1	R166	RESISTOR	DAIICHI
166	1	R167	RESISTOR	DAIICHI
167	1	R168	RESISTOR	DAIICHI
168	1	R169	RESISTOR	DAIICHI
169	1	R170	RESISTOR	DAIICHI
170	1	R171	RESISTOR	DAIICHI
171	1	R172	RESISTOR	DAIICHI
172	1	R173	RESISTOR	DAIICHI
173	1	R174	RESISTOR	DAIICHI
174	1	R175	RESISTOR	DAIICHI
175	1	R176	RESISTOR	DAIICHI
176	1	R177	RESISTOR	DAIICHI
177	1	R178	RESISTOR	DAIICHI
178	1	R179	RESISTOR	DAIICHI
179	1	R180	RESISTOR	DAIICHI
180	1	R181	RESISTOR	DAIICHI
181	1	R182	RESISTOR	DAIICHI
182	1	R183	RESISTOR	DAIICHI
183	1	R184	RESISTOR	DAIICHI
184	1	R185	RESISTOR	DAIICHI
185	1	R186	RESISTOR	DAIICHI
186	1	R187	RESISTOR	DAIICHI
187	1	R188	RESISTOR	DAIICHI
188	1	R189	RESISTOR	DAIICHI
189	1	R190	RESISTOR	DAIICHI
190	1	R191	RESISTOR	DAIICHI
191	1	R192	RESISTOR	DAIICHI
192	1	R193	RESISTOR	DAIICHI
193	1	R194	RESISTOR	DAIICHI
194	1	R195	RESISTOR	DAIICHI
195	1	R196	RESISTOR	DAIICHI
196	1	R197	RESISTOR	DAIICHI
197	1	R198	RESISTOR	DAIICHI
198	1	R199	RESISTOR	DAIICHI
199	1	R200	RESISTOR	DAIICHI
200	1	R201	RESISTOR	DAIICHI
201	1	R202	RESISTOR	DAIICHI
202	1	R203	RESISTOR	DAIICHI
203	1	R204	RESISTOR	DAIICHI
204	1	R205	RESISTOR	DAIICHI
205	1	R206	RESISTOR	DAIICHI
206	1	R207	RESISTOR	DAIICHI
207	1	R208	RESISTOR	DAIICHI
208	1	R209	RESISTOR	DAIICHI
209	1	R210	RESISTOR	DAIICHI
210	1	R211	RESISTOR	DAIICHI
211	1	R212	RESISTOR	DAIICHI
212	1	R213	RESISTOR	DAIICHI
213	1	R214	RESISTOR	DAIICHI
214	1	R215	RESISTOR	DAIICHI
215	1	R216	RESISTOR	DAIICHI
216	1	R217	RESISTOR	DAIICHI
217	1	R218	RESISTOR	DAIICHI
218	1	R219	RESISTOR	DAIICHI
219	1	R220	RESISTOR	DAIICHI
220	1	R221	RESISTOR	DAIICHI
221	1	R222	RESISTOR	DAIICHI
222	1	R223	RESISTOR	DAIICHI
223	1	R224	RESISTOR	DAIICHI
224	1	R225	RESISTOR	DAIICHI
225	1	R226	RESISTOR	DAIICHI
226	1	R227	RESISTOR	DAIICHI
227	1	R228	RESISTOR	DAIICHI
228	1	R229	RESISTOR	DAIICHI
229	1	R230	RESISTOR	DAIICHI
230	1	R231	RESISTOR	DAIICHI
231	1	R232	RESISTOR	DAIICHI
232	1	R233	RESISTOR	DAIICHI
233	1	R234	RESISTOR	DAIICHI
234	1	R235	RESISTOR	DAIICHI
235	1	R236	RESISTOR	DAIICHI
236	1	R237	RESISTOR	DAIICHI
237	1	R238	RESISTOR	DAIICHI
238	1	R239	RESISTOR	DAIICHI
239	1	R240	RESISTOR	DAIICHI
240	1	R241	RESISTOR	DAIICHI
241	1	R242	RESISTOR	DAIICHI
242	1	R243	RESISTOR	DAIICHI
243	1	R244	RESISTOR	DAIICHI
244	1	R245	RESISTOR	DAIICHI
245	1	R246	RESISTOR	DAIICHI
246	1	R247	RESISTOR	DAIICHI
247	1	R248	RESISTOR	DAIICHI
248	1	R249	RESISTOR	DAIICHI
249	1	R250	RESISTOR	DAIICHI
250	1	R251	RESISTOR	DAIICHI
251	1	R252	RESISTOR	DAIICHI
252	1	R253	RESISTOR	DAIICHI
253	1	R254	RESISTOR	DAIICHI
254	1	R255	RESISTOR	DAIICHI
255	1	R256	RESISTOR	DAIICHI
256	1	R257	RESISTOR	DAIICHI
257	1	R258	RESISTOR	DAIICHI
258	1	R259	RESISTOR	DAIICHI
259	1	R260	RESISTOR	DAIICHI
260	1	R261	RESISTOR	DAIICHI
261	1	R262	RESISTOR	DAIICHI
262	1	R263	RESISTOR	DAIICHI
263	1	R264	RESISTOR	DAIICHI
264	1	R265	RESISTOR	DAIICHI
265	1	R266	RESISTOR	DAIICHI
266	1	R267	RESISTOR	DAIICHI
267	1	R268	RESISTOR	DAIICHI
268	1	R269	RESISTOR	DAIICHI
269	1	R270	RESISTOR	DAIICHI
270	1	R271	RESISTOR	DAIICHI
271	1	R272	RESISTOR	DAIICHI
272	1	R273	RESISTOR	DAIICHI
273	1	R274	RESISTOR	DAIICHI
274	1	R275	RESISTOR	DAIICHI
275	1	R276	RESISTOR	DAIICHI
276	1	R277	RESISTOR	DAIICHI
277	1	R278	RESISTOR	DAIICHI
278	1	R279	RESISTOR	DAIICHI
279	1	R280	RESISTOR	DAIICHI
280	1	R281	RESISTOR	DAIICHI
281	1	R282	RESISTOR	DAIICHI
282	1	R283	RESISTOR	DAIICHI
283	1	R284	RESISTOR	DAIICHI
284	1	R285	RESISTOR	DAIICHI
285	1	R286	RESISTOR	DAIICHI
286	1	R287	RESISTOR	DAIICHI
287	1	R288	RESISTOR	DAIICHI
288	1	R289	RESISTOR	DAIICHI
289	1	R290	RESISTOR	DAIICHI
290	1	R291	RESISTOR	DAIICHI
291	1	R292	RESISTOR	DAIICHI
292	1	R293	RESISTOR	DAIICHI
293	1	R294	RESISTOR	DAIICHI
294	1	R295	RESISTOR	DAIICHI
295	1	R296	RESISTOR	DAIICHI
296	1	R297	RESISTOR	DAIICHI
297	1	R298	RESISTOR	DAIICHI
298	1	R299	RESISTOR	DAIICHI
299	1	R300	RESISTOR	DAIICHI

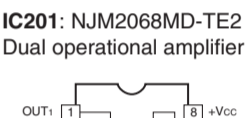
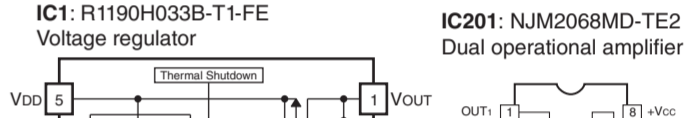

No.	Symbol	Description
1	VOUT	Output Pin
2	GROUND	Ground Pin
3	CE	Capacitor Pin (Not using)
4	DELAY	Delay Pin (Not using)
5	Vo	Input Pin

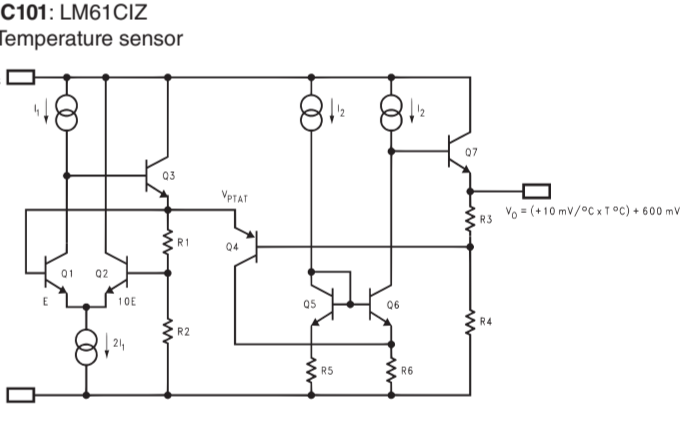

IC203: RSF100JEAFA
16 bit single chip microprocessor

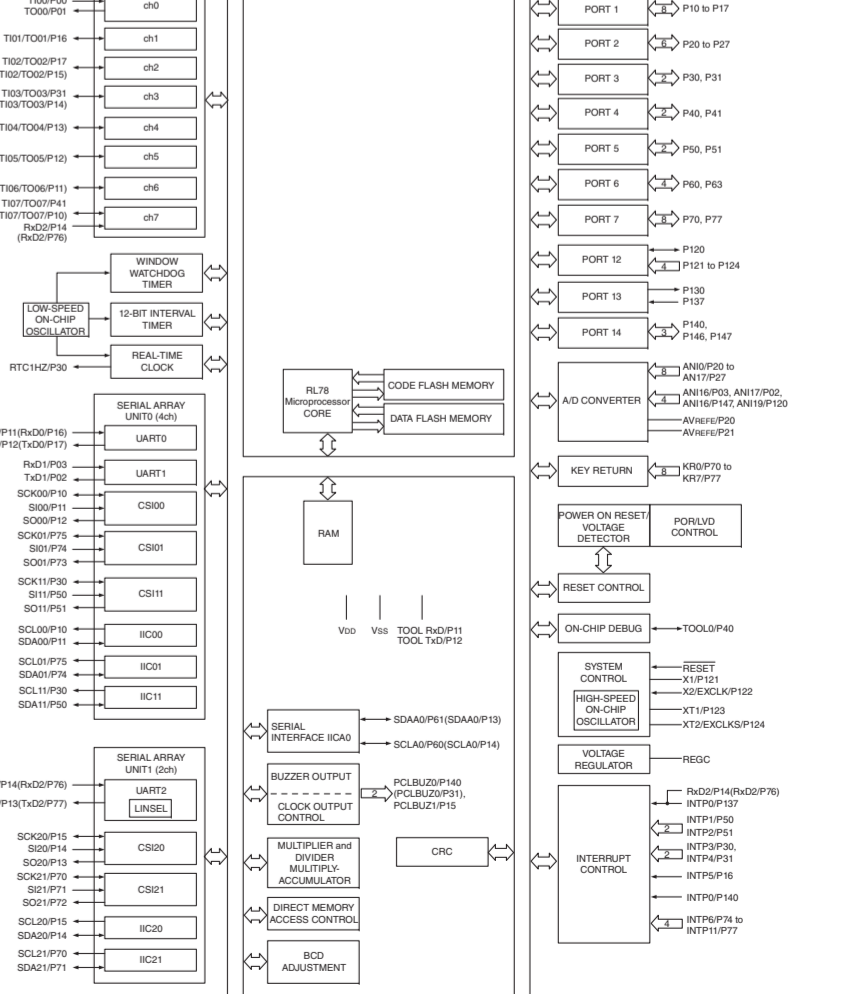

* All voltages are measured with a 10MΩ/V DC electronic voltmeter.
* Components having special characteristics are marked Δ and must be replaced with parts having specifications equal to those originally installed.
* Schematic diagram is subject to change without notice.

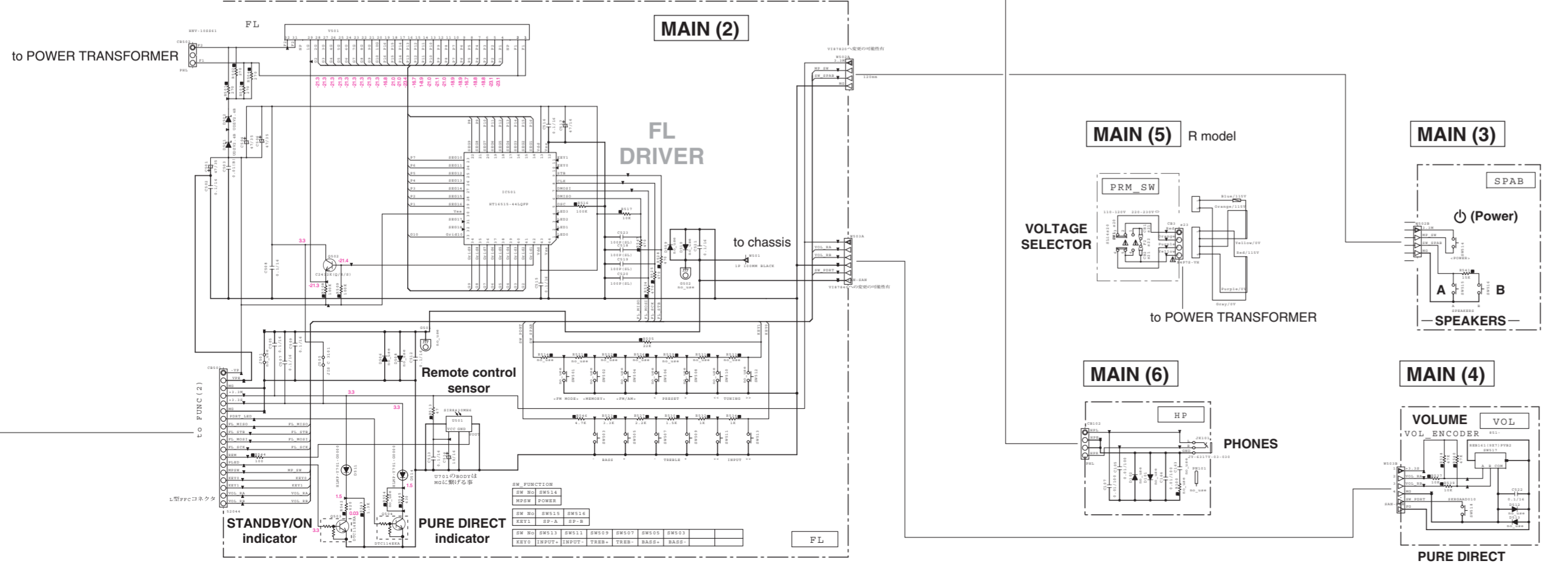

Key detection for A/D port
Key input (A/D) pull-up resistance 10 k-ohms

Detected voltage value at 40 pin	0 Ω	+1.0 kΩ	+1.0 kΩ	+1.5 kΩ	+2.2 kΩ	+3.3 kΩ	+4.7 kΩ
A/D value (3.3 V = 255)	000 - 011	012 - 032	033 - 054	055 - 079	080 - 107	108 - 134	135 - 160
KEY0	INPUT	INPUT	TREBLE	TREBLE	BASS	BASS	PURE DIRECT

Detected voltage value at 41 pin	+7.5 kΩ	+15 kΩ
A/D value (3.3 V = 255)	161 - 187	188 - 214
KEY1	SPEAKER A	SPEAKER B

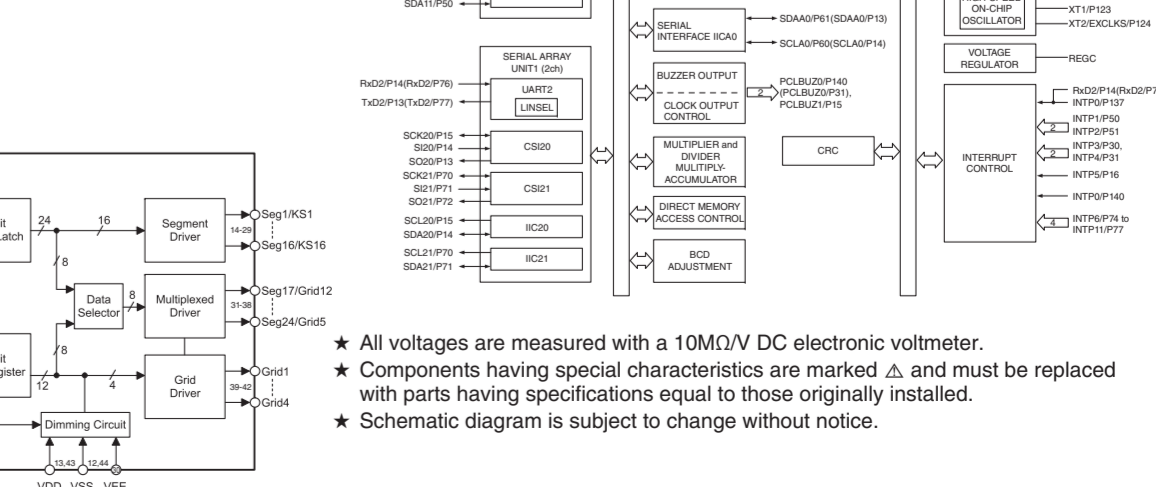
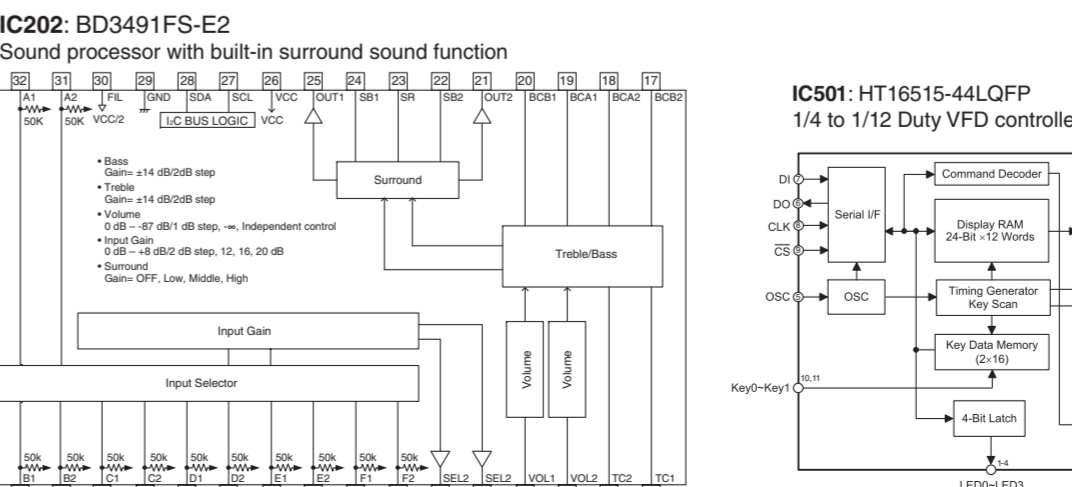

1
2
3
4
5
6
7
8
9
10

■ REPLACEMENT PARTS LIST

• ELECTRICAL COMPONENT PARTS

WARNING

- Components having special characteristics are marked Δ and must be replaced with parts having specifications equal to those originally installed.

ABBREVIATIONS IN THIS LIST ARE AS FOLLOWS:

C.A.EL.CHP	: CHIP ALUMI.ELECTROLYTIC CAP	LED.CHP	: CHIP LED
C.CE	: CERAMIC CAP	LED.DSPLY	: LED DISPLAY
C.CE.ARRAY	: CERAMIC CAP ARRAY	LED.INFRD	: LED,INFRARED
C.CE.CHP	: CHIP CERAMIC CAP	PHOT.CPL	: PHOTO COUPLER
C.CE.M.CHP	: CHIP MULTILAYER CERAMIC CAP	PHOT.INTR	: PHOTO INTERRUPTER
C.CE.SAFTY	: RECOGNIZED CERAMIC CAP	PHOT.RFLCT	: PHOTO REFLECTOR
C.CE.TUBLR	: CERAMIC TUBULAR CAP	PHOT.TR	: PHOTO TRANSISTOR
C.CE.SMI	: SEMI CONDUCTIVE CERAMIC CAP	PIN.TEST	: PIN, TEST POINT
C.EL	: ELECTROLYTIC CAP	PTC.THERM	: POSITIVE TEMPERATURE COEFFICIENT THERMISTOR
C.EL.BP	: BIPOLAR ELECTROLYTIC CAP	R.ANTI.SURGE	: FIXED ANTI SURGE RESISTOR
C.EL.CHP	: CHIP ELECTROLYTIC CAP	R.ARRAY	: RESISTOR ARRAY
C.MICA	: MICA CAP	R.CAR.	: CARBON RESISTOR
C.ML.FLM	: MULTILAYER FILM CAP	R.CAR.CHP	: CHIP RESISTOR
C.MP	: METALLIZED POLYESTER FILM CAP	R.CAR.FP	: FLAME PROOF CARBON RESISTOR
C.MYLAR	: MYLAR FILM CAP	R.CEMENT	: CEMENT RESISTOR
C.MYLAR.ML	: MULTILAYER MYLAR FILM CAP	R.CHP	: CHIP RESISTOR
C.NIOB.OXD	: NIOBIUM OXIDE CAP	R.FUS	: FUSIBLE RESISTOR
C.PAPER	: PAPER CAPACITOR	R.MTL.CHP	: CHIP METAL FILM RESISTOR
C.PLS	: POLYSTYRENE FILM CAP	R.MTL.FLM	: METAL FILM RESISTOR
C.POL	: POLYESTER FILM CAP	R.MTL.OXD	: METAL OXIDE FILM RESISTOR
C.PP	: POLYPROPYLENE FILM CAP	R.MTL.PLAT	: METAL PLATE RESISTOR
C.PP.CHP	: CHIP POLYPROPYLENE FILM CAP	RSNR.CE	: CERAMIC RESONATOR
C.TNTL	: TANTALIUM CAP	RSNR.CRYS	: CRYSTAL RESONATOR
C.TNTL.CHP	: CHIP TANTALIUM CAP	SCR.BND.HD	: BIND HEAD B-TIGHT SCREW
C.TRIM	: TRIMMER CAP	SCR.TERM	: SCREW TERMINAL
CN	: CONNECTOR	SCR.TR	: SCREW,TRANSISTOR
CN.BS.PIN	: CONNECTOR,BASE PIN	SURG.PRTCT	: SURGE PROTECTOR
CN.CANNON	: CONNECTOR,CANNON	SUPRT.PCB	: P.C.B. SUPPORT
CN.DIN	: CONNECTOR,DIN	SW.LEVER	: LEVER SWITCH
CN.FLAT	: CONNECTOR,FLAT CABLE	SW.MICRO	: MICRO SWITCH
CN.FFC	: CONNECTOR,FLEXIBLE FLAT CABLE	SW.LEAF	: LEAF SWITCH
CN.HDMI	: HDMI CONNECTOR	SW.PUSH	: PUSH SWITCH
CN.PHOTO.R	: PHOTO FIBER SENSOR,RECEIVED	SW.RT	: ROTARY SWITCH
CN.PHOTO.T	: PHOTO FIBER SENSOR,TRANSMITTED	SW.RT.ENC	: ROTARY ENCODER
D.SCHOTTKY	: SCHOTTKY BARRIER DIODE	SW.RT.MTR	: ROTARY SWITCH WITH MOTOR
DIODE.ARRAY	: DIODE ARRAY	SW.SLIDE	: SLIDE SWITCH
DIODE.BRG	: DIODE BRIDGE	SW.TACT	: TACT SWITCH
DIODE.CHP	: CHIP DIODE	TERM.SP	: SPEAKER TERMINAL
DIODE.VAR	: VARACTOR DIODE	TERM.WRAP	: WRAPPING TERMINAL
DIODE.ZENR	: ZENER DIODE	THRMST.CHP	: CHIP THERMISTOR
DIODE.Z.CHP	: CHIP ZENER DIODE	TR	: TRANSISTOR
DIODE.PHOT	: PHOTO DIODE	TR.CHP	: CHIP TRANSISTOR
FER.BEAD	: FERRITE BEADS	TR.DGT	: DIGITAL TRANSISTOR
FER.CORE	: FERRITE CORE	TR.DGT.CHP	: CHIP DIGITAL TRANSISTOR
FET.CHP	: CHIP FET	TR.PAIR	: PAIR TRANSISTOR
FL.DSPLY	: FLUORESCENT DISPLAY	TRANS	: TRANSFORMER
FLTR.CE	: CERAMIC FILTER	TRANS.PULS	: PULSE TRANSFORMER
FLTR.COMB	: COMB FILTER MODULE	TRANS.PWR	: POWER TRANSFORMER
FLTR.LC.RF	: LC FILTER,EMI	VARISTOR.C	: CHIP VARISTOR
FUSE.CHP	: CHIP FUSE	VOLT.SELCT	: VOLTAGE SELECTOR
GND.MTL	: GROUND PLATE	VR	: ROTARY POTENTIOMETER
GND.TERM	: GROUND TERMINAL	VR.MTR	: POTENTIOMETER WITH MOTOR
JUMPER.CN	: JUMPER CONNECTOR	VR.SLIDE	: SLIDE POTENTIOMETER
JUMPER.TST	: JUMPER,TEST POINT	VR.SW	: POTENTIOMETER WITH SWITCH
L.DTCT	: LIGHT DETECTING MODULE	VR.TRIM	: TRIMMER POTENTIOMETER

MAIN

A-S201

Ref No.	Part No.	Description	Markets
*	ZH174800	P. C. B. MAIN	R
*	ZH174900	P. C. B. MAIN	T
*	ZH175000	P. C. B. MAIN	K
*	ZH922600	P. C. B. MAIN	A
*	ZH175100	P. C. B. MAIN	BG
*	ZH175200	P. C. B. MAIN	L
	CB1-2	WN103000 CL IP. FUSE	TP00351-31 R
	CB3	V9377900 CN. BS. PIN	4P R
△	CB4	VG879900 CN. BS. PIN	2P
△	CB5-6	WN103000 CL IP. FUSE	TP00351-31
△	CB7	VG879900 CN. BS. PIN	2P
	CB101	VB389900 CN. BS. PIN	3P
	CB102	VB858300 CN. BS. PIN	4P
	CB103	LB932030 CN. BS. PIN	3P
	CB201	VQ044400 CN. BS. PIN	9P
	CB204	VP573800 CN. BS. PIN	18P
	CB501	VQ044800 CN. BS. PIN	18P
	CB502	VB858200 CN. BS. PIN	3P
	C1	UR828470 C. EL	470uF 10V
	C2-3	WHO46700 C. CE. M. CHP	4. 7uF 16V
	C4	US035100 C. CE. CHP	0. 1uF 16V B
△	C6	WQ939400 C. CE. SAFTY	0. 01uF 250V
	C7	UR849220 C. EL	2200uF 25V
*	C8	WW194100 C. MYLAR	0. 1uF 100V
	C9	US063100 C. CE. CHP	1000pF 50V B
	C10	UR867100 C. EL	10uF 50V R
*	C11	WW194100 C. MYLAR	0. 1uF 100V R
	C12	US063100 C. CE. CHP	1000pF 50V B
*	C13	WW194100 C. MYLAR	0. 1uF 100V R
	C14	UR866100 C. EL	1uF 50V R
	C15	UR866330 C. EL	3. 3uF 50V
	C101-102	US061470 C. CE. CHP	47pF 50V B
	C103-104	UR867100 C. EL	10uF 50V
*	C105	WN200100 C. CE. M. CHP	0. 01uF 100V
	C106	US062100 C. CE. CHP	100pF 50V B
*	C107	WN200100 C. CE. M. CHP	0. 01uF 100V
	C108-109	WJ608100 C. MYLAR	100pF 100V
	C110-111	UR838100 C. EL	100uF 16V
	C112-113	US060500 C. CE. CHP	5pF 50V B
	C114	US062150 C. CE. CHP	150pF 50V B
	C117-119	US062150 C. CE. CHP	150pF 50V B
	C120	UR897470 C. EL	47uF 100V
	C121-122	UR897100 C. EL	10uF 100V
	C123	UR897470 C. EL	47uF 100V
	C124-125	UR897100 C. EL	10uF 100V
	C130	UR866220 C. EL	2. 2uF 50V
	C131-132	WJ610600 C. MYLAR	0. 022uF 100V
	C137	UR818100 C. EL	100uF 6. 3V
	C138	US135100 C. CE. CHP	0. 1uF 16V
*	C140	ZH987600 C. EL	6800uF 66V
	C142	UR867470 C. EL	47uF 50V
*	C143	ZH987600 C. EL	6800uF 66V
	C144	UR848330 C. EL	330uF 25V
	C145	UR858100 C. EL	100uF 35V
	C146	UR866470 C. EL	4. 7uF 50V
	C147	UR867100 C. EL	10uF 50V
	C148	US064100 C. CE. CHP	0. 01uF 50V B

* New Parts

Ref No.	Part No.	Description	Markets
*	C149-150	UR779100 C. EL	1000uF 63V
	C151-153	US064100 C. CE. CHP	0. 01uF 50V B
*	C154-155	WW194100 C. MYLAR	0. 1uF 100V
	C156	US064100 C. CE. CHP	0. 01uF 50V B
*	C157	WN200100 C. CE. M. CHP	0. 01uF 100V TKABGL
*	C159-161	WN200100 C. CE. M. CHP	0. 01uF 100V TKABGL
*	C164	WN200100 C. CE. M. CHP	0. 01uF 100V
*	C165-167	WW194100 C. MYLAR	0. 1uF 100V
	C168-169	UR877330 C. EL	33uF 63V
	C170-171	WJ608100 C. MYLAR	100pF 100V
*	C172	WW194100 C. MYLAR	0. 1uF 100V
*	C177-180	WN200100 C. CE. M. CHP	0. 01uF 100V TKABGL
*	C189-190	WN200100 C. CE. M. CHP	0. 01uF 100V TKABGL
	C201	US135100 C. CE. CHP	0. 1uF 16V
	C202-205	US062220 C. CE. CHP	220pF 50V B
	C206-207	US061470 C. CE. CHP	47pF 50V B
	C208-213	US062220 C. CE. CHP	220pF 50V B
	C214-215	UR237100 C. EL	10uF 16V
	C216-217	UR837100 C. EL	10uF 16V
	C220-221	WJ610800 C. MYLAR	0. 033uF 100V
	C222-223	WJ610100 C. MYLAR	9100pF 100V
	C224-225	UR838330 C. EL	330uF 16V
	C226-227	UR837100 C. EL	10uF 16V
	C228-229	WJ609300 C. MYLAR	2200pF 100V
	C230-231	UR867100 C. EL	10uF 50V
	C234-245	UR867100 C. EL	10uF 50V
*	C246-247	WJ609200 C. MYLAR	1800pF 100V
	C248-251	UR865220 C. EL	0. 22uF 50V
	C252	US135100 C. CE. CHP	0. 1uF 16V
	C259-260	UR866100 C. EL	1uF 50V
	C261	US135100 C. CE. CHP	0. 1uF 16V
	C262-264	UR867100 C. EL	10uF 50V
	C265	US063100 C. CE. CHP	1000pF 50V B
	C266-267	UR866220 C. EL	2. 2uF 50V
	C268-270	US063100 C. CE. CHP	1000pF 50V B
	C271	US135100 C. CE. CHP	0. 1uF 16V
	C272	US046100 C. CE. CHP	1uF 25V
	C273	UR828220 C. EL	220uF 10V
	C274	US062100 C. CE. CHP	100pF 50V B
	C276	UR866100 C. EL	1uF 50V
	C277	US135100 C. CE. CHP	0. 1uF 16V
	C278	UR828100 C. EL	100uF 10V
	C279	US062100 C. CE. CHP	100pF 50V B
	C280	US135100 C. CE. CHP	0. 1uF 16V
	C281	US063100 C. CE. CHP	1000pF 50V B
	C282	US135100 C. CE. CHP	0. 1uF 16V
	C283-284	US063100 C. CE. CHP	1000pF 50V B
	C285-286	US062220 C. CE. CHP	220pF 50V B KABGL
*	C288	WW194100 C. MYLAR	0. 1uF 100V
	C289	US163100 C. CE. CHP	1000pF 50V
	C501	WQ711900 C. EL	47uF 35V
	C502	US035100 C. CE. CHP	0. 1uF 16V B
	C503	US064100 C. CE. CHP	0. 01uF 50V B
	C504	WQ711900 C. EL	47uF 35V
	C505	US035100 C. CE. CHP	0. 1uF 16V B
	C506	WQ711900 C. EL	47uF 35V
	C507-509	US035100 C. CE. CHP	0. 1uF 16V B

* New Parts

MAIN

Ref No.	Part No.	Description	Markets
C512-513	US035100	C. CE. CHP 0. 1uF 16V B	
C514	UM397100	C. EL 10uF 16V	
C515-516	US035100	C. CE. CHP 0. 1uF 16V B	
C517	UM397470	C. EL 47uF 16V	
C518-520	US062100	C. CE. CHP 100pF 50V B	
C521-522	US035100	C. CE. CHP 0. 1uF 16V B	
C523	US062100	C. CE. CHP 100pF 50V B	
D1-4	WW783900	DIODE 1SS355VM	
D5	WY163100	DIODE. ZENR UDZV4. 7B	
D6	WY164100	DIODE. ZENR UDZV12B	R
Δ D7	WH471700	DIODE. BRG DB105 1A 600V	
D8	WU201600	DIODE 1N4003S TP	R
D9-10	WW783900	DIODE 1SS355VM	
D103-106	ZA984400	DIODE BAV103	
D108	WY163800	DIODE. ZENR UDZV9. 1B	
D109	WY164800	DIODE. ZENR UDZV24B	
D110	WW783900	DIODE 1SS355VM	
Δ D111-112	WU201600	DIODE 1N4003S TP	
Δ D113	VN953300	DIODE. BRG D5SBA60 5A 600V	
D114	WW783900	DIODE 1SS355VM	
D115	WY164300	DIODE. ZENR UDZV15B	
* D116	WY164900	DIODE. ZENR UDZV27B	
D117	WW783900	DIODE 1SS355VM	
Δ D118	WH471700	DIODE. BRG DB105 1A 600V	
D119-120	WY165200	DIODE. ZENR UDZV36B	R
D201-202	WY163400	DIODE. ZENR UDZV6. 2B	
D203-204	WY163100	DIODE. ZENR UDZV4. 7B	
D207	WY163100	DIODE. ZENR UDZV4. 7B	
* D501-502	WZ443400	DIODE. ZENR UDZV2. 4B	
D511	WZ745700	LED HLMP-Y701-G0000	
D514	WZ745700	LED HLMP-Y701-G0000	
Δ F1	WQ211100	FUSE 8A 125V	UCR
Δ F1	VV071800	FUSE 4A 250V	TKABGL
Δ F2	VV071800	FUSE 4A 250V	R
G101	V5995800	PLATE. GND	
Δ * IC1	YD268A00	IC R1190H033B-T1-FE	
IC101	X0515B00	IC LM61C1Z THERMAL	
IC201	X3505A00	IC NJM2068MD-TE2	
* IC202	YF439A00	IC BD3491FS	
IC203	YF832A00	IC. CPU R5F100JEAFA	(unwritten)
* IC501	YF471A00	IC HT16515-44LQFP	
JK101	V4478300	JACK. PHONE JY-6317Y-03-030	
PJ201	WN303900	JACK. PIN 6P RJ-1074+09-OH54	
PJ202	WD195400	JACK. PIN 6P	
Q1	WH445000	FET 3LN01C-TB-E	
Q2	ZC298400	TR 2SA1037AK R, S TP	
* Q3	ZE933000	TR KTC4376-Y-RTF/P	
Δ * Q5	ZG245700	TR KTA1661-Y-RTF/P	R
Q6-7	WC397600	TR 2N5401S-RTK/P	R
Q8	WC398300	TR 2N5551S-RTK/P	R
Q101-104	WD896300	TR 2SA1514K R, S	
Q105-106	WC292200	TR KTC3206Y-AT	
Δ Q107-108	WC883400	TR 2SD2704 K	
Δ * Q109	ZG214200	TR KTD600K-Y-U/PH	
Δ * Q110-111	ZG214100	TR KTB631K Y, GR	
Δ * Q112	ZG214200	TR KTD600K-Y-U/PH	
Δ # Q113-116	ZD043300	TR. POWER 2STC4468	

* New Parts **Note)** Those parts marked with "#" are not included in the P.C.B. assembly.

Ref No.	Part No.	Description	Markets
Q117-118	WF549900	TR 2SC3906K T146 R, S	
Q119-120	WC397600	TR 2N5401S-RTK/P	
Q122	WC398300	TR 2N5551S-RTK/P	
Q123	ZE918100	TR KTA1664-Y-RTF/P	
* Q124	ZE933000	TR KTC4376-Y-RTF/P	
Q125	WC398300	TR 2N5551S-RTK/P	
Q126	WC397600	TR 2N5401S-RTK/P	
Q127-128	WC398300	TR 2N5551S-RTK/P	
Δ * Q129	ZG245700	TR KTA1661-Y-RTF/P	
Δ * Q130	ZG245800	TR KTC4373-Y-RTF/P	
Q131	WC397600	TR 2N5401S-RTK/P	
Q132-133	WC398300	TR 2N5551S-RTK/P	
Q201-204	WC883400	TR 2SD2704 K	
Q205-206	VV556500	TR 2SA1037K Q, R, S	
Q208	VV655400	TR. DGT DTC114EKA	
Q209	WQ381000	FET MCH6336-TL-E	
Q502	VV556400	TR 2SC2412K Q, R, S	
Q503-504	VV655400	TR. DGT DTC114EKA	
* R9	WW862500	R. CAR. FP 22 Ω 1/4W	
R11	WW975700	R. MTL. OXD 47K Ω 1/4W	R
R14	WW975700	R. MTL. OXD 47K Ω 1/4W	R
R102-103	V8071300	R. MTL. FLM 470 Ω 1W	
* R135-136	WW865700	R. CAR. FP 5. 6K Ω 1/4W	
* R137-138	WW865100	R. CAR. FP 2. 2K Ω 1/4W	
Δ R139	WW863300	R. CAR. FP 100 Ω 1/4W	
* R140-141	WW863900	R. CAR. FP 330 Ω 1/4W	
Δ R142	WW863300	R. CAR. FP 100 Ω 1/4W	
Δ R143-146	WW861300	R. CAR. FP 2. 2 Ω 1/4W	
Δ * R147-148	ZG861500	R. WW 0. 1 Ω 2W	
Δ R159-160	V8070300	R. MTL. FLM 10 Ω 1W	
R162-163	WW862100	R. CAR. FP 10 Ω 1/4W	
Δ * R166-167	VC762500	R. MTL. OXD 2. 7K Ω 2W	
* R170	WW863700	R. CAR. FP 220 Ω 1/4W	
R175	WW863300	R. CAR. FP 100 Ω 1/4W	
* R178	WW864600	R. CAR. FP 1K Ω 1/4W	
* R179	WW865100	R. CAR. FP 2. 2K Ω 1/4W	
* R186	WW863200	R. CAR. FP 82 Ω 1/4W	RTL
* R186	WW863900	R. CAR. FP 330 Ω 1/4W	KABG
* R187-188	WW865200	R. CAR. FP 2. 4K Ω 1/4W	
* R191	WW863200	R. CAR. FP 82 Ω 1/4W	RTL
* R191	WW863900	R. CAR. FP 330 Ω 1/4W	KABG
* R192	WW975500	R. MTL. OXD 39K Ω 1/4W	
* R193	WW866600	R. CAR. FP 22K Ω 1/4W	
* R196	WW863200	R. CAR. FP 82 Ω 1/4W	RL
* R196	WW863900	R. CAR. FP 330 Ω 1/4W	AG
Δ * R314-317	WW862500	R. CAR. FP 22 Ω 1/4W	
* R318-320	WW863800	R. CAR. FP 270 Ω 1/4W	
Δ * R321-322	VC762500	R. MTL. OXD 2. 7K Ω 2W	
Δ RY1	WQ804100	RELAY DC DLS5D1-0(M) 0. 25	
Δ * RY101-103	ZJ359600	RELAY 981-2A-48DS-SP7	
ST1	V4040500	SCR. TERM M3	
ST101	WA246200	SCR. TERM 3. 5	
ST102-103	V4040500	SCR. TERM M3	
Δ SW1	WV382900	SW. SLIDE SL14	R
SW517	WU974000	SW. RT. ENC REB161 (9X7) PVB20F I	
SW518	WD483100	SW. TACT SKRGAAD010	
Δ T1	YF765A00	TRANS	R

* New Parts

A-S201

MAIN

	Ref No.	Part No.	Description	Markets
△	T1	YF766A00	TRANS	TKABGL
	TE102	ZH270100	TERM. SP	8P BANANA RTA
	TE102	ZH270200	TERM. SP	8P NON-BANANA KBGL
	U501	WW715100	L. DTCT	S1R8430MH6
	V501	ZG358500	FL. DSPLY	HNV-10SS61
*		ZG943300	FL. SPACER	
		WP935100	HOLDER	1P

	Ref No.	Part No.	Description	Markets

* New Parts

* New Parts

A-S201

Carbon Resistors

Value	1/4W Type Part No.	1/6W Type Part No.	Value	1/4W Type Part No.	1/6W Type Part No.
1.0 Ω	HJ35 3100	HF85 3100	11 kΩ	HF45 7110	HF45 7110
1.8 Ω	HJ35 3180	*	12 kΩ	HJ35 7120	HF85 7120
2.2 Ω	HJ35 3220	HF85 3220	13 kΩ	HF45 7130	HF45 7130
3.3 Ω	HJ35 3330	HF85 3330	15 kΩ	HF45 7150	HF45 7150
4.7 Ω	HJ35 3470	HF85 3470	18 kΩ	HF45 7180	HF45 7180
5.6 Ω	HJ35 3560	HF85 3560	22 kΩ	HF45 7220	HF45 7220
10 Ω	HF45 4100	HF45 4100	24 kΩ	HF45 7240	HF45 7240
15 Ω	HJ35 4150	HF85 4150	27 kΩ	HJ35 7270	HF85 7270
22 Ω	HF45 4220	HF45 4220	30 kΩ	HF45 7300	HF45 7300
27 Ω	HJ35 4270	HF85 4270	33 kΩ	HF45 7330	HF45 7330
33 Ω	HF45 4330	HF45 4330	36 kΩ	HF45 7360	HF45 7360
39 Ω	HJ35 4470	HF85 4390	39 kΩ	HF45 7390	HF45 7390
47 Ω	HF45 4470	HF45 4470	47 kΩ	HF45 7470	HF45 7470
56 Ω	HF45 4560	HF45 4560	51 kΩ	HF45 7510	HF45 7510
68 Ω	HF45 4680	HF45 4680	56 kΩ	HF45 7560	HF45 7560
75 Ω	HF45 4750	HF45 4750	62 kΩ	HF45 7620	HF45 7620
82 Ω	HF45 4820	HF45 4820	68 kΩ	HF45 7680	HF45 7680
91 Ω	HF45 4910	HF45 4910	82 kΩ	HF45 7820	HF45 7820
100 Ω	HF45 5100	HF45 5100	91 kΩ	HF45 7910	HF45 7910
110 Ω	HJ35 5110	HF85 5110	100 kΩ	HF45 8100	HF45 8100
120 Ω	HF45 5120	HF45 5120	110 kΩ	HF45 8110	HF45 8110
150 Ω	HF45 5150	HF45 5150	120 kΩ	HF45 8120	HF45 8120
160 Ω	HJ35 5160	*	130 kΩ	HF45 8130	*
180 Ω	HF45 5180	HF45 5180	150 kΩ	HF45 8150	HF45 8150
200 Ω	HF45 5200	HF45 5200	180 kΩ	HF45 8180	HF45 8180
220 Ω	HF45 5220	HF45 5220	220 kΩ	HJ35 8220	HF85 8220
270 Ω	HF45 5270	HF45 5270	270 kΩ	HF45 8270	HF45 8270
330 Ω	HF45 5330	HF45 5330	300 kΩ	HF45 8300	HF45 8300
390 Ω	HF45 5390	HF45 5390	330 kΩ	HF45 8330	HF45 8330
430 Ω	HF45 5430	HF45 5430	390 kΩ	HJ35 8390	HF85 8390
470 Ω	HF45 5470	HF45 5470	470 kΩ	HF45 8470	HF45 8470
510 Ω	HF45 5510	HF45 5510	560 kΩ	HJ35 8560	HF85 8560
560 Ω	HF45 5560	HF45 5560	680 kΩ	HJ35 8680	HF85 8680
680 Ω	HF45 5680	HF45 5680	820 kΩ	HJ35 8820	HF85 8820
820 Ω	HF45 5820	HF45 5820	1.0 MΩ	HF45 9100	HF45 9100
910 Ω	HF45 5910	HF45 5910	1.2 MΩ	HJ35 9120	*
1.0 kΩ	HF45 6100	HF45 6100	1.5 MΩ	HJ35 9150	HF85 9150
1.2 kΩ	HF45 6120	HF45 6120	1.8 MΩ	HJ35 9180	HF85 9180
1.5 kΩ	HF45 6150	HF45 6150	2.2 MΩ	HJ35 9220	HF85 9220
1.8 kΩ	HF45 6180	HF45 6180	3.3 MΩ	HJ35 9330	HF85 9330
2.0 kΩ	HJ35 6200	HF85 6200	3.9 MΩ	HJ35 9390	*
2.2 kΩ	HF45 6220	HF45 6220	4.7 MΩ	HJ35 9470	HF85 9470
2.4 kΩ	HJ35 6240	HF85 6240			
2.7 kΩ	HF45 6270	HF45 6270			
3.0 kΩ	HF45 6300	HF45 6300			
3.3 kΩ	HF45 6330	HF45 6330			
3.6 kΩ	HJ35 6360	HF85 6360			
3.9 kΩ	HF45 6390	HF45 6390			
4.7 kΩ	HF45 6470	HF45 6470			
5.1 kΩ	HF45 6510	HF45 6510			
5.6 kΩ	HF45 6560	HF45 6560			
6.8 kΩ	HF45 6680	HF45 6680			
8.2 kΩ	HF45 6820	HF45 6820			
9.1 kΩ	HF45 6910	HF45 6910			
10 kΩ	HF45 7100	HF45 7100			

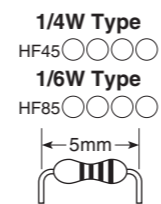
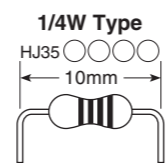

* : Not available

• OVERALL ASSEMBLY

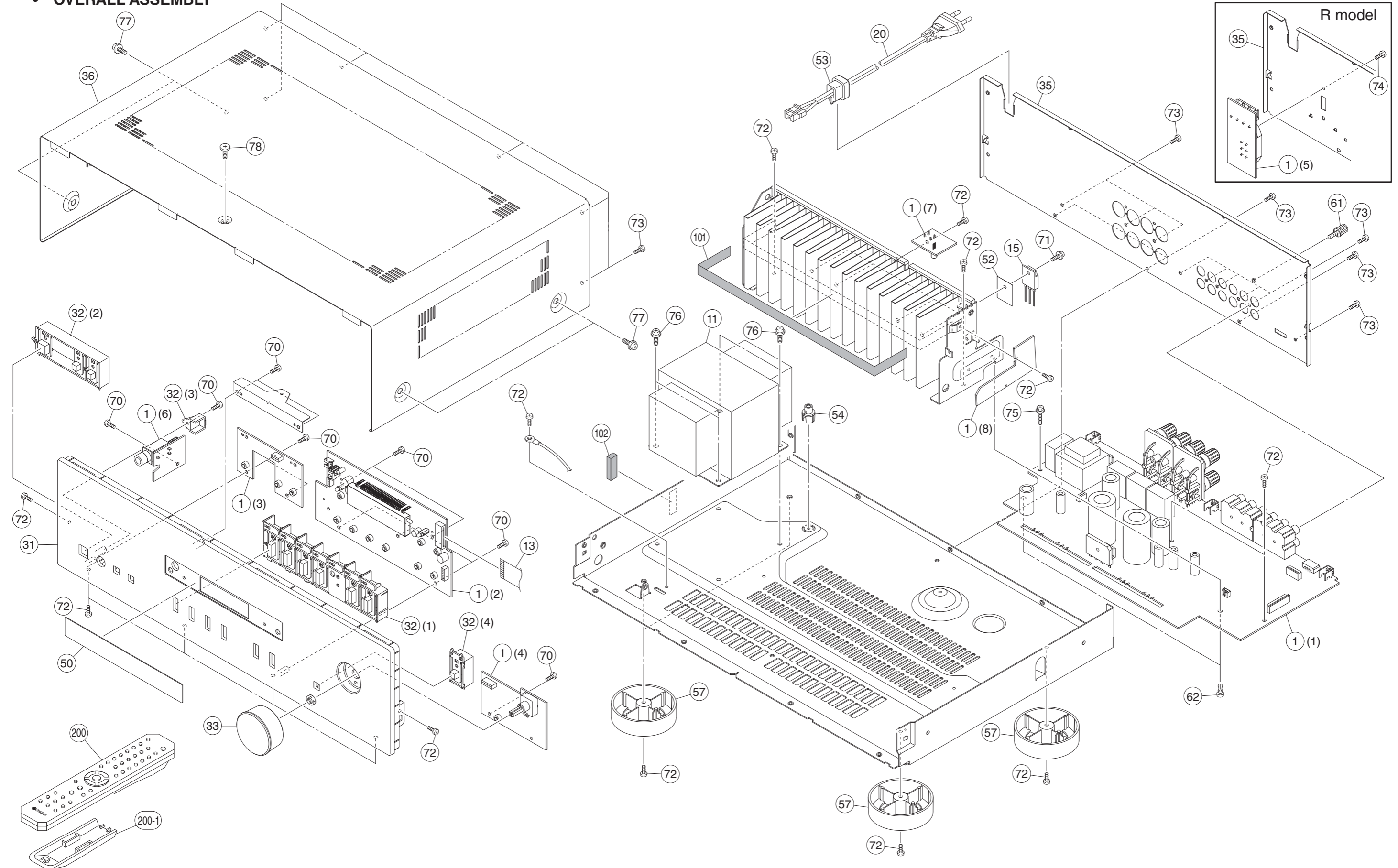

Ref No.	Part No.	Description	Remarks	Markets
* 1	ZH174800	P. C. B. ASSEMBLY	MAIN	R
* 1	ZH174900	P. C. B. ASSEMBLY	MAIN	T
* 1	ZH175000	P. C. B. ASSEMBLY	MAIN	K
* 1	ZH922600	P. C. B. ASSEMBLY	MAIN	A
* 1	ZH175100	P. C. B. ASSEMBLY	MAIN	BG
* 1	ZH175200	P. C. B. ASSEMBLY	MAIN	L
△ * 11	YF700A00	POWER TRANSFORMER		R
△ * 11	YF701A00	POWER TRANSFORMER		T
△ * 11	YF702A00	POWER TRANSFORMER		K
△ * 11	YF703A00	POWER TRANSFORMER		A
△ * 11	YF705A00	POWER TRANSFORMER		BG
△ * 11	YF704A00	POWER TRANSFORMER		L
	13	MF118300	FLEXIBLE FLAT CABLE	18P 300mm P=1.25
#	15	ZD043300	TRANSISTOR	2STC4468
△	20	WY042500	POWER CABLE	1.8m
△	20	WY042600	POWER CABLE	1.8m
△	20	WY042400	POWER CABLE	1.8m
△	20	WY042100	POWER CABLE	1.8m
△	20	WY041100	POWER CABLE	1.8m
△	20	WY041700	POWER CABLE	1.8m
* 31	ZG936700	FRONT PANEL		BL
* 31	ZG936800	FRONT PANEL		SI
* 32	ZG937100	BUTTON SET	Ax1, Bx1, Cx1, Dx1	BL
* 32	ZG937200	BUTTON SET	Ax1, Bx1, Cx1, Dx1	SI
* 33	ZH629500	KNOB	VOLUME	BL
* 33	ZH629600	KNOB	VOLUME	SI
* 35	ZG941400	REAR PANEL		R
* 35	ZG941500	REAR PANEL		T
* 35	ZG941600	REAR PANEL		K
* 35	ZG941700	REAR PANEL		A
* 35	ZG941900	REAR PANEL		BG
* 35	ZG942000	REAR PANEL		L
* 36	ZG942200	TOP COVER		BL
* 36	ZG942300	TOP COVER		SI
* 50	ZG943100	WINDOW SHEET		
	52	VV849300	RADIATION SHEET	19x24
	53	V2438700	CORD STOPPER	10P1
	54	WQ664500	SUPPORT	H8
	57	ZC181800	LEG	D60/H21 Black
	61	AA627310	GROUND TERMINAL	
	62	VQ368600	PUSH RIVET	P3555-B
	70	WE774800	BIND HEAD P-TIGHT SCREW	3x8 MFZN2W3
	71	VK173200	SCREW TRANSISTOR	3x15 SP MFC2
	72	WE774300	BIND HEAD B-TIGHT SCREW	3x8 MFZN2W3

* New Parts

Finish BL: Black color, SI: Silver color

Note) Those parts marked with “#” are not included in the P.C.B. assembly.

Ref No.	Part No.	Description	Remarks	Markets
73	WE774100	BIND HEAD BONDING B-T. SCREW	3x8 MFZN2B3	
74	WE877900	BIND HEAD S-TIGHT SCREW	3x6 MFZN2W3	R
75	WE774600	HEXAGONAL HEAD B-TIGHT SCREW	3x18 MFZN2W3	
76	WU048900	BIND HEAD S-TIGHT SCREW	4x10 MFZN2W3	
77	VH313200	PW HEAD S-TIGHT SCREW	4x8-10 MFN13BL	BL
77	VDO69600	PW HEAD S-TIGHT SCREW	4x8-10 MFN133	SI
78	WE200500	DISH HEAD B-TIGHT SCREW	3x6 MFN13BL	BL
78	WE200400	DISH HEAD B-TIGHT SCREW	3x6 MFN133	SI
101	WQ621800	DAMPER	2x10x310	
102	V5881000	DAMPER	2x15x20	
		ACCESSORIES		
* 200	ZG936400	REMOTE CONTROL	RAS2, 7060N-01-0001	
200-1	AAX13340	BATTERY COVER	Black	60050001
		BATTERY	LR6, AA, UM-3 2pcs	
		SERVICE TOOL		
* 200	ZK189200	RS-232C CONVERSION ADAPTOR	V5.0 without FFC	
	ZD896000	FLEXIBLE FLAT CABLE	9P 150mm P=1.25	SMCD-9X150-BDX2

* New Parts

Finish BL: Black color, SI: Silver color

REMOTE CONTROL

SCHEMATIC DIAGRAM

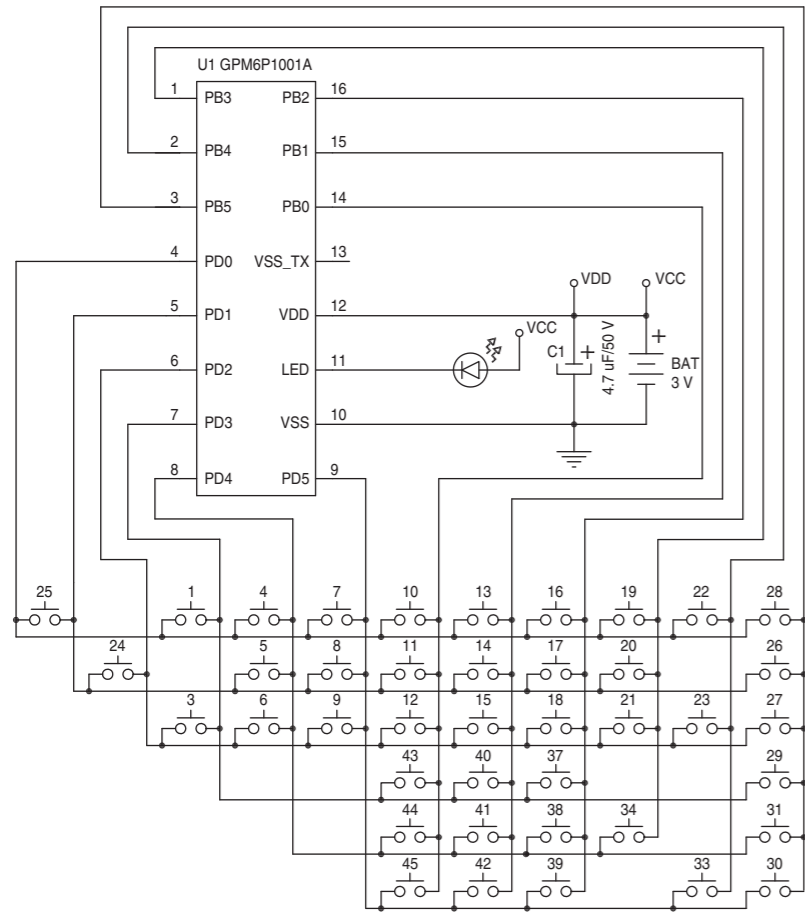

PANEL

RAS2

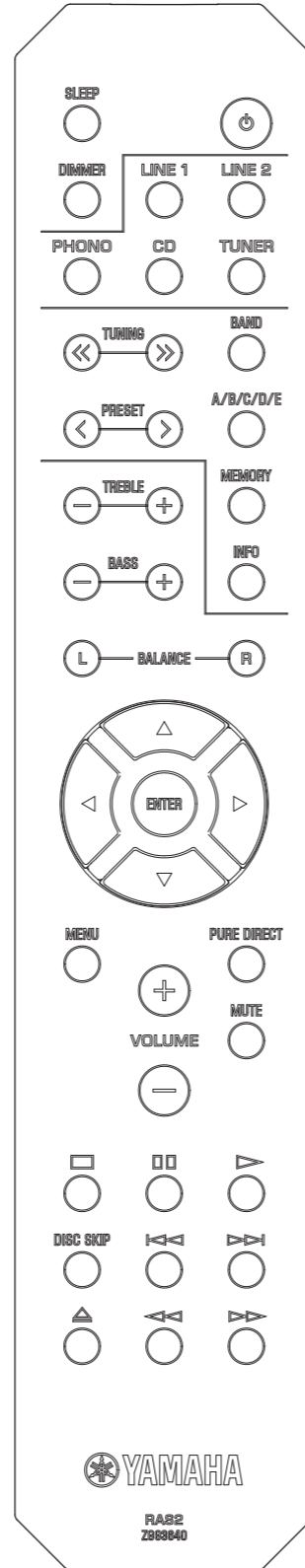

KEY NO. LAYOUT

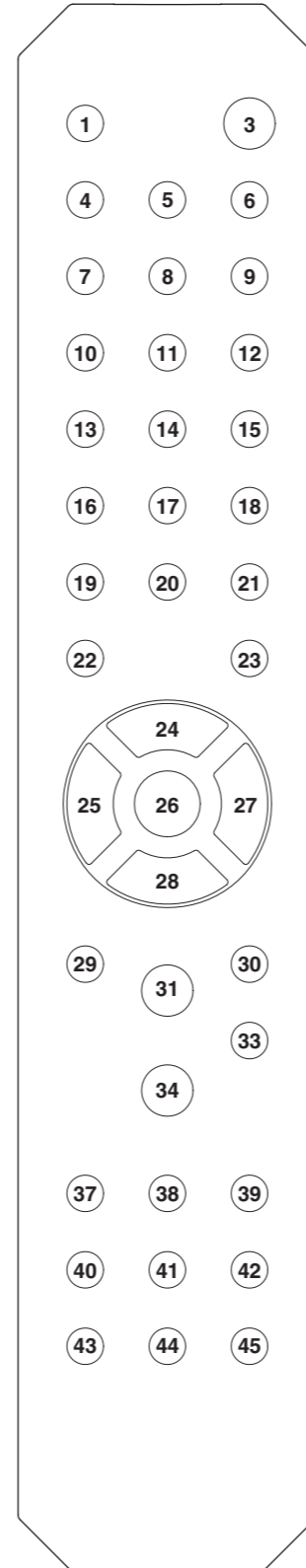

KEY CODE

Key No.	Key Name	Code
1	SLEEP	7A-30CE
3	⏻ STANDBY/ON	7E-2AD4
4	DIMMER	7A-82FC
5	LINE 1	7A-C13F
6	LINE 2	7A-18E6
7	PHONO	7A-14EA
8	CD	7A-15EB
9	TUNER	7A-16E8
10	TUNING ⏪	7F01-641B
11	TUNING ⏩	7F01-611E
12	BAND	7A-AE
13	PRESET <	7A-11
14	PRESET >	7A-10
15	A/B/C/D/E	7A-12
16	TREBLE -	7A-BAC4
17	TREBLE +	7A-B9C7
18	MEMORY	7A-AF
19	BASS -	7A-B8C6
20	BASS +	7A-B7C9
21	INFO	7A-A4
22	BALANCE L	7A-BBC5
23	BALANCE R	7A-BCC2
24	▲ (up)	7A-9D63
25	◀ (left)	7A-9F61
26	ENTER	7A-DE20
27	▶ (right)	7A-9E60
28	▼ (down)	7A-9C62
29	MENU	7A-847A
30	PURE DIRECT	7 A-DD23
31	VOLUME +	7A-1AE4
33	MUTE	7A-1CE2
34	VOLUME -	7A-1BE5
37	■ (stop)	79-56
38	▬▬ (pause)	79-55
39	▶▶ (play)	79-02
40	DISC SKIP	79-4F
41	◀◀ (skip-)	79-04
42	▶▶ (skip+)	79-07
43	▲ (open/close)	79-01
44	◀◀ (search-)	79-05
45	▶▶ (search+)	79-06

■ ADVANCED SETUP

SETTING THE OPTION MENU FOR EACH INPUT SOURCE

The Option menu allows you to configure various settings for each input source and recall those settings automatically when an input source is selected.

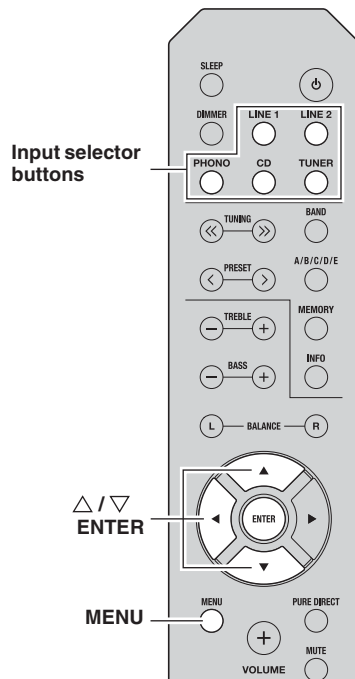

- 1 Press one of the Input selector buttons to select the desired input source.
- 2 Press MENU.
- 3 Press Δ / ∇ to select the desired menu item, and then press ENTER.
- 4 Press Δ / ∇ to change the settings.
 - ☀ For certain menu items, you must press ENTER to save the new setting.
 - ☀ To return to the screen where you can select menu items, press \triangleleft .
- 5 To exit the Option menu, press MENU.

Option menu items

Available menu items vary depending on the selected input source.

Menu item	Description
MAX VOL	Sets the maximum volume level so that the volume will not be accidentally increased above a certain level. Adjustable range: 01 to 99, MAX*
INITIAL VOLUME (INIT VOL)	Sets the volume at the time this unit is turned on. When this parameter is set to "OFF", the volume level used when this unit was set to standby is applied. Adjustable range: OFF*, MUTE, 01 to 99, MAX
AUTO POWER STANDBY (AUTO STBY)	Sets this unit to standby mode automatically if no operation is performed in the specified time. Choices: OFF/2H/4H/8H*/12H



The default settings are marked with "*".

A-S201

