

COMPACT SYSTEM AV-S7 SERVICE MANUAL

AV-S7

AV-S7 is composed of NX-AVS7, SW-AVS7 and NX-AV1.

IMPORTANT NOTICE

This manual has been provided for the use of authorized YAMAHA Retailers and their service personnel. It has been assumed that basic service procedures inherent to the industry, and more specifically YAMAHA Products, are already known and understood by the users, and have therefore not been restated.

WARNING: Failure to follow appropriate service and safety procedures when servicing this product may result in personal injury, destruction of expensive components, and failure of the product to perform as specified. For these reasons, we advise all YAMAHA product owners that any service required should be performed by an authorized YAMAHA Retailer or the appointed service representative.

IMPORTANT: The presentation or sale of this manual to any individual or firm does not constitute authorization, certification or recognition of any applicable technical capabilities, or establish a principle-agent relationship of any form.

The data provided is believed to be accurate and applicable to the unit(s) indicated on the cover. The research, engineering, and service departments of YAMAHA are continually striving to improve YAMAHA products. Modifications are, therefore, inevitable and specifications are subject to change without notice or obligation to retrofit. Should any discrepancy appear to exist, please contact the distributor's Service Division.

WARNING: Static discharges can destroy expensive components. Discharge any static electricity your body may have accumulated by grounding yourself to the ground buss in the unit (heavy gauge black wires connect to this buss).

IMPORTANT: Turn the unit OFF during disassembly and part replacement. Recheck all work before you apply power to the unit.

■ CONTENTS

TO SERVICE PERSONNEL	1	SW-AVS7 IC DATA	12~15
FRONT PANELS	1~2	BLOCK DIAGRAM	16~17
REAR PANELS	2~3	NX-AVS7 PRINTED CIRCUIT BOARD	18~19
SPECIFICATIONS	4	SW-AVS7 PRINTED CIRCUIT BOARD	20~26
INTERNAL VIEW	5	PIN CONNECTION DIAGRAM	27
SW-AVS7 DISASSEMBLY PROCEDURES	5~6	SW-AVS7 SCHEMATIC DIAGRAM	28~29
NX-AVS7 DISASSEMBLY PROCEDURES	6	NX-AVS7 SCHEMATIC DIAGRAM	29
TEST PROGRAM FUNCTION SELECT MODE	7	PARTS LIST	30~44
DSP SELF-DIAGNOSIS FUNCTION	8~9	REMOTE CONTROL TRANSMITTER	45
NX-AVS7 IC DATA	10~11	MICROPROCESSOR & VOLUME FUNCTION	46

100623

Copyright 2004 YAMAHA CORPORATION
This manual is copyrighted by YAMAHA and may not be copied or redistributed either in print or electronically without permission.

YAMAHA
YAMAHA CORPORATION
P.O. Box 1, Hamamatsu, Japan

2.8K-434 Printed in Japan '98.5

■ TO SERVICE PERSONNEL

1. Critical Components Information.
Components having special characteristics are marked Δ and must be replaced with parts having specifications equal to those originally installed.
2. Leakage Current Measurement (For 120V Models Only).
When service has been completed, it is imperative to verify that all exposed conductive surfaces are properly insulated from supply circuits.
 - Meter impedance should be equivalent to 1500 ohm shunted by 0.15 μ F.

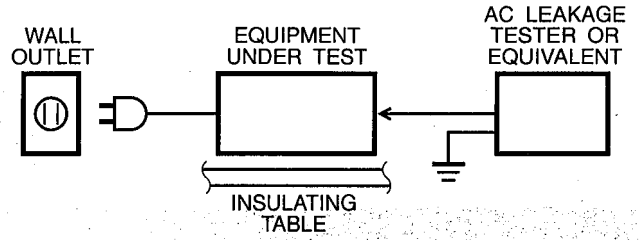

- Leakage current must not exceed 0.5mA.
- Be sure to test for leakage with the AC plug in both polarities.

WARNING: CHEMICAL CONTENT NOTICE!

The solder used in the production of this product contains LEAD. In addition, other electrical/electronic and/or plastic (where applicable) components may also contain traces of chemicals found by the California Health and Welfare Agency (and possibly other entities) to cause cancer and/or birth defects or other reproductive harm.

DO NOT PLACE SOLDER, ELECTRICAL/ELECTRONIC OR PLASTIC COMPONENTS IN YOUR MOUTH FOR ANY REASON WHATSOEVER!

Avoid prolonged, unprotected contact between solder and your skin! When soldering, do not inhale solder fumes or expose eyes to solder/flux vapor!

If you come in contact with solder or components located inside the enclosure of this product, wash your hands before handling food.

■ FRONT PANELS

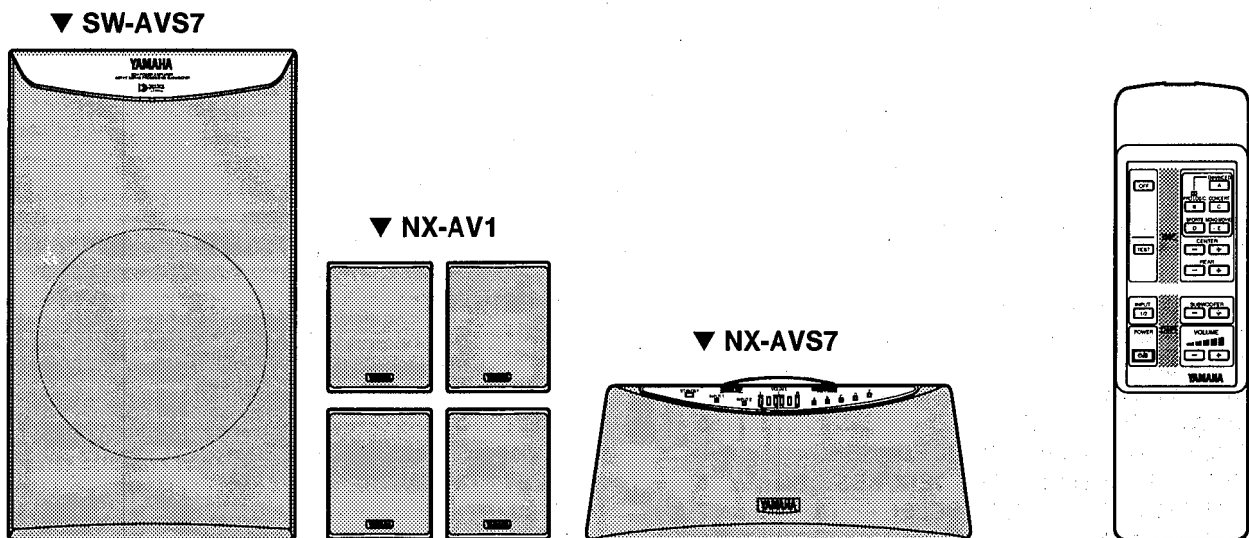

NX-AVS7 Front

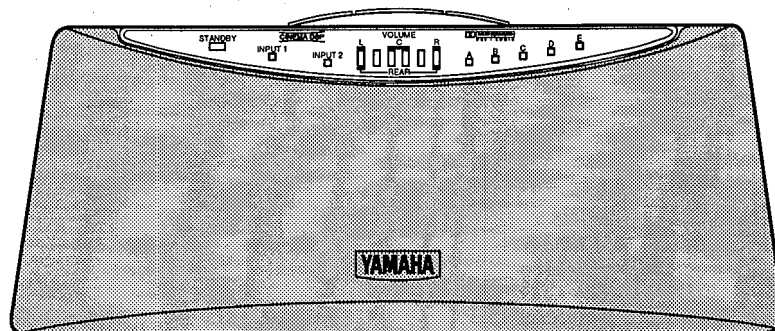

NX-AVS7 Top

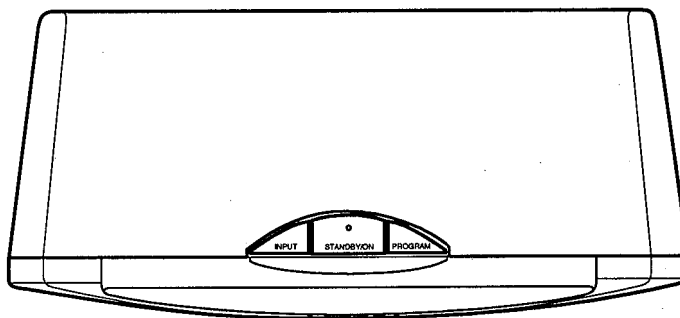

■ REAR PANELS

▼ NX-AVS7 Rear

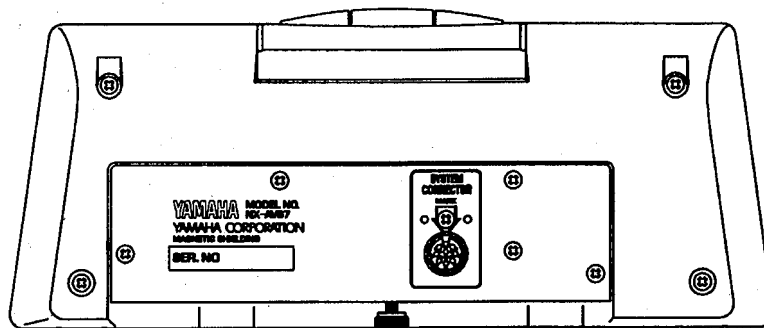

AV-S7

REAR PANELS

SW-AV1 Rear

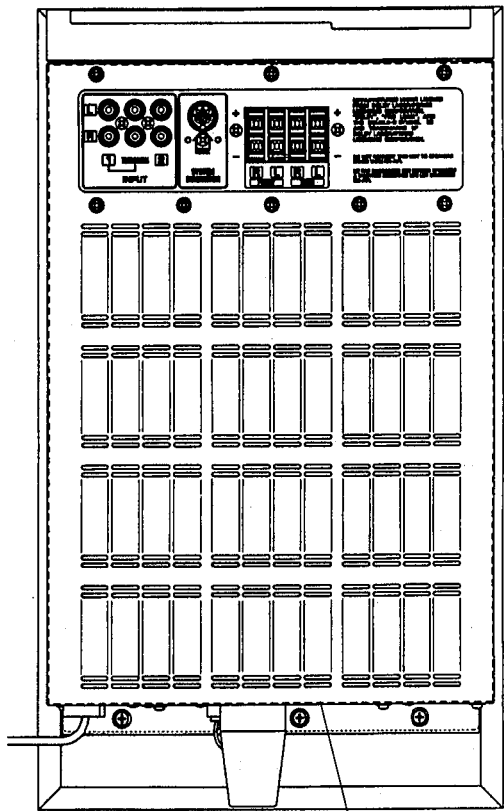
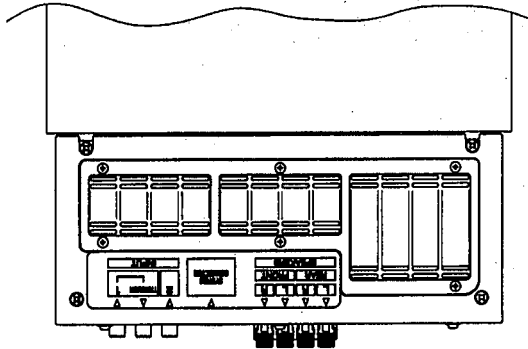

Bottom Panel

NX-AV1

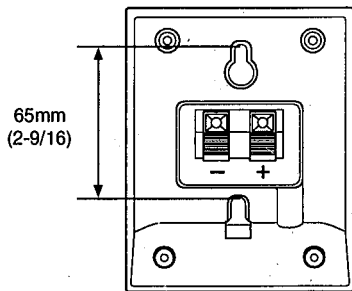

SW-AVS7 U model

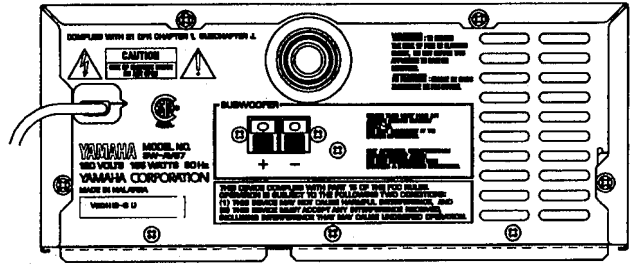

SW-AVS7 C model

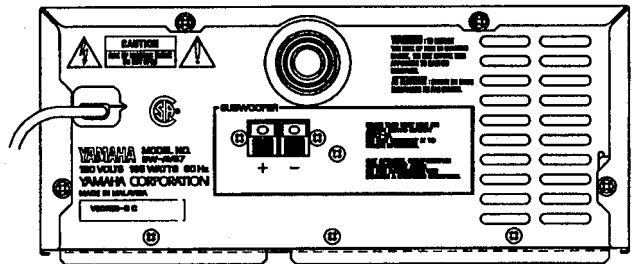

SW-AVS7 A model

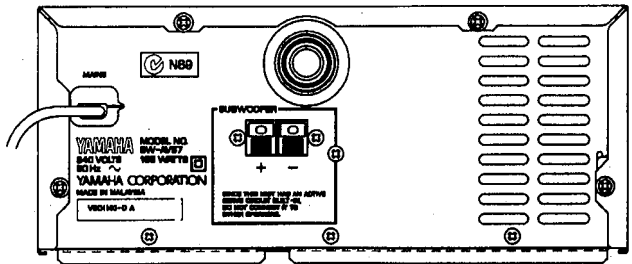

SW-AVS7 B, G models

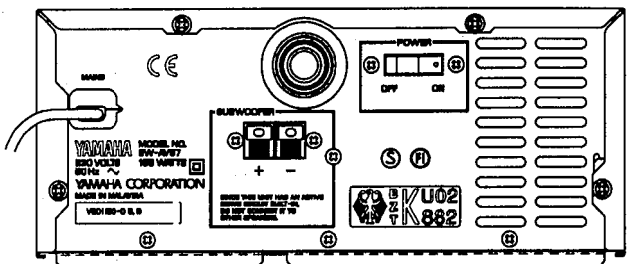

SW-AVS7 R, T models

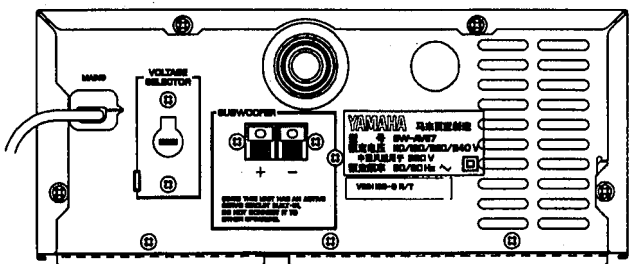

SPECIFICATIONS

AMPLIFIER SECTION

Signal to Noise Ratio (IHF-A-Network, AUX, Shorted)
 INPUT 1 85dB

Total Harmonic Distortion (1kHz)
 INPUT 1 to Speaker Out, 12.5W/6Ω 0.08%

Minimum RMS Output Power per Channel

Front (1kHz, 10% THD, 6Ω) 30W
 Center (1kHz, 10% THD, 6Ω) 30W
 Rear (1kHz, 10% THD, 6Ω) 30W
 Sub Woofer (100Hz, 10% THD, 4Ω) 50W

DIN Standard Output Power per Channel (G only)
 1kHz, 1% THD, 6Ω 25W

IEC Power (G only)
 1kHz, 0.1% THD, 6Ω 20W

Input Sensitivity/Impedance
 INPUT 1 100mV/20kΩ

NX-AV1 FRONT & REAR SPEAKER SECTION

Type 1-way 1 speaker closed cabinet type
 (Magnetic-Shielding Type)

Speakers 8cm (3-1/8") cone

Maximum Power Handling Capacity 40W(15.5V)

Impedance 6Ω

NX-AVS7 CENTER SPEAKER SECTION

Type 1-way 1 speaker closed cabinet type
 (Magnetic-Shielding Type)

Speakers 8cm (3-1/8") cone

Maximum Power Handling Capacity 40W(15.5V)

Impedance 6Ω

SW-AVS7 SUB WOOFER SPEAKER SECTION

Type 1-way 1 speaker YST-style bass reflex type
 (Magnetic-Shielding Type)

Speakers 20cm (7-7/8") cone

Maximum Power Handling Capacity 60W(15.5V)

Impedance 4Ω

GENERAL

Power Supply

U, C models AC120V, 60Hz
 A model AC240V, 50Hz
 B, G models AC230V, 50Hz
 R, T models AC110/120/220/240V, 60/50Hz

Power Consumption 155W

Dimensions (W X H X D)

SW-AVS7 250 X 425 X 418mm
 (13-13/16" X 16-3/4" X 16-7/16")

NX-AVS7 280 X 117 X 125mm
 (11" X 4-5/8" X 4-15/16")

NX-AV1 94 X 117 X 108mm
 (3-11/16" X 4-5/8" X 4-1/4")

Weight

SW-AVS7 14.5kg (31 lbs. 15 oz)
 NX-AVS7 1.3kg (2 lbs. 13 oz)/each
 NX-AV1 0.7kg (1 lbs. 8 oz)

Accessories

System Cord (DIN plug) X 1
 Pin Cord (RCA) X 1
 Remote Control Transmitter X 1
 Battery (size "AA", R06) X 2
 Stand Assy (front) X 2
 Wall Bracket (rear) X 2
 Bracket X 4
 Fastener Tape X 2
 Screw Assy X 1
 Speaker Cable (15m) X 2
 Speaker Cable (6m) X 2

* Specifications subject to change without notice.

* Manufactured under license from Dolby Laboratories Licensing Corporation. "DOLBY", "PRO LOGIC", and the double-D symbol $\square\square$ are trademarks of Dolby Laboratories Licensing Corporation.

- U U.S.A. model G European model
 C Canadian model R General model
 A Australian model T China model
 B British model

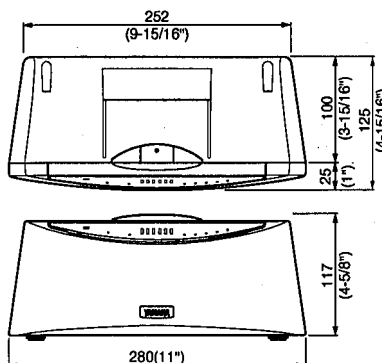
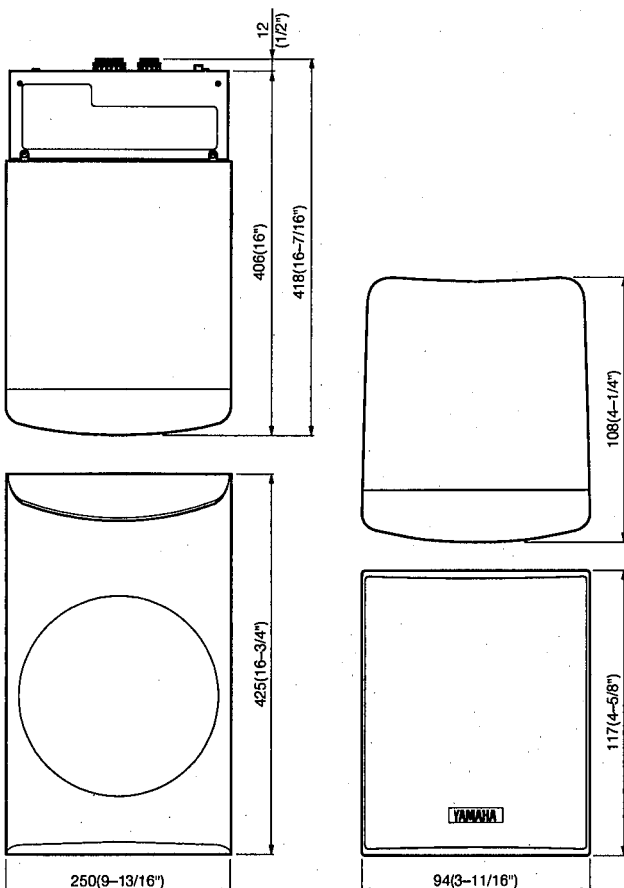

Unit : mm (inch)

INTERNAL VIEW

SW-AVS7

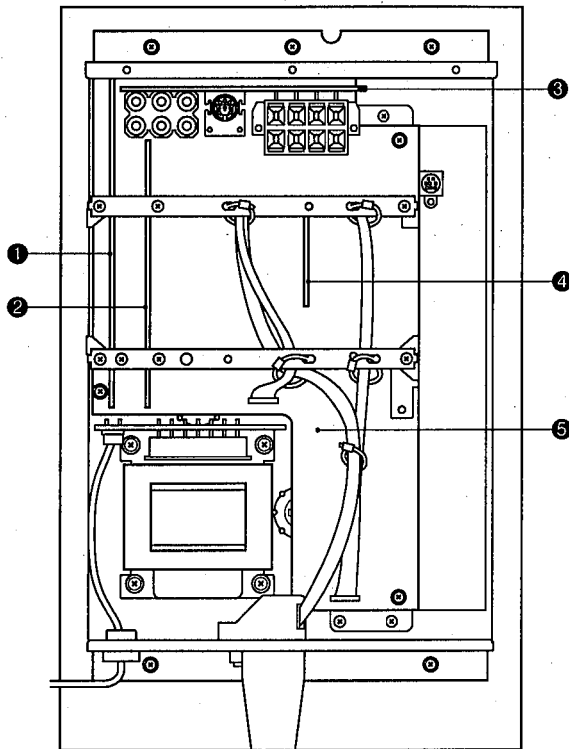

- ① P.C.B. DSP
- ② P.C.B. VOLUME (2)
- ③ P.C.B. VOLUME (1)
- ④ P.C.B. AMP (2)
- ⑤ P.C.B. AMP (1)

AV-S7

SW-AVS7 DISASSEMBLY PROCEDURES (Remove parts in the order as numbered.)

1. Removal of Amp Unit

- a. Remove the speaker cord in Fig. 1.
- b. Remove 4 screws (①) and then remove the Grille Unit in Fig. 1.
- c. Remove 6 screws (②) and then remove the Amp Unit in Fig. 1.

2. Removal of Top Cover & Rear Panel

- a. Remove 18 screws (③) and then remove the Top Cover in Fig. 2.
- b. Remove 9 screws (④) and then remove the Rear Panel in Fig. 2.

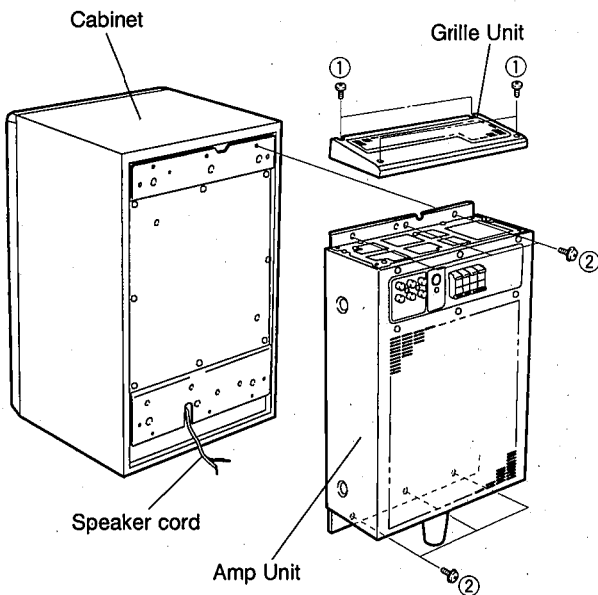

Fig. 1

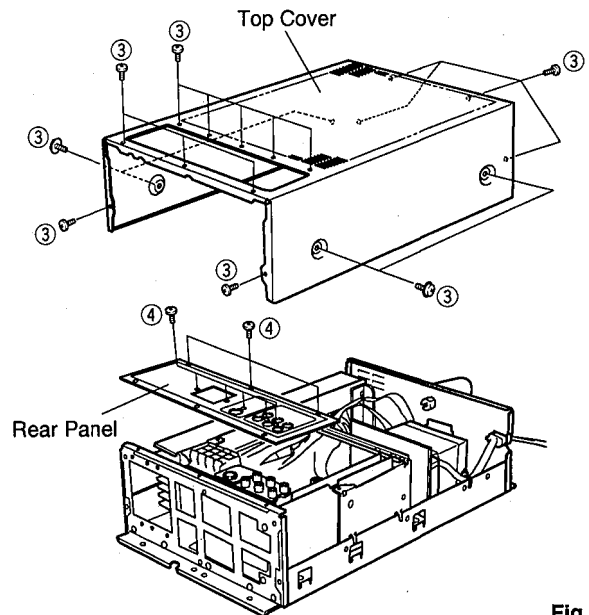

Fig. 2

3. Removal of Grille Ass'y & Top Panel

- a. Insert a flat tip screwdriver or the like as shown below and pry up the Grille Ass'y. (Start from the bottom side.) (Fig. 3)
- b. Repeat prying it up toward the top panel side until the Grille Ass'y and the Top Panel come off.

The Grille Ass'y is attached with dowels at 6 locations and the Top Panel at 3 locations. When removing them, use care not to cause damage to the main unit.

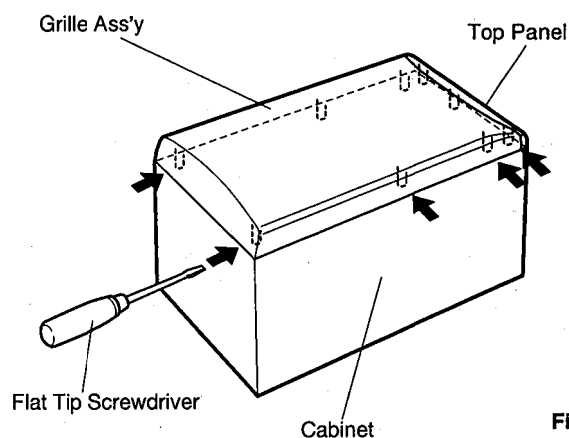

Fig. 3

■ NX-AVS1 DISASSEMBLY PROCEDURES (Remove parts in the order as numbered.)

1. Removal of Rear Panel

Remove 4 screws (⑤) and then remove the Rear Panel in Fig. 4.

2. Removal of Grille Ass'y

- a. Using a flat tip screwdriver or the like from the underside, push up the Grille Ass'y as shown in Fig.5.
- b. Keep pushing up the Grille Ass'y gradually with a flat tip screwdriver or the like toward the Top Panel until it comes off.

The Grill Ass'y is attached by 4 dowels, be very careful not to cause damage to the main unit when removing it. When installing the Grill Ass'y, apply quick-drying bond to the dowels and then fit them into dowel holes for secure installation. (The Grille Ass'y will come off easily if its dowels are fitted into dowel holes only.)

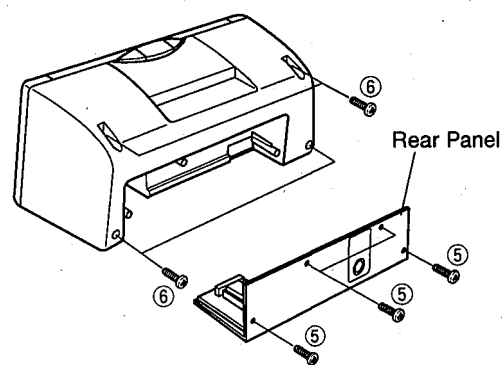

Fig. 4

3. Removal of Baffle

- a. Remove 4 screws (⑥) in Fig. 4.
- b. Remove 2 screws (⑦) and then remove the Baffle in Fig. 6.

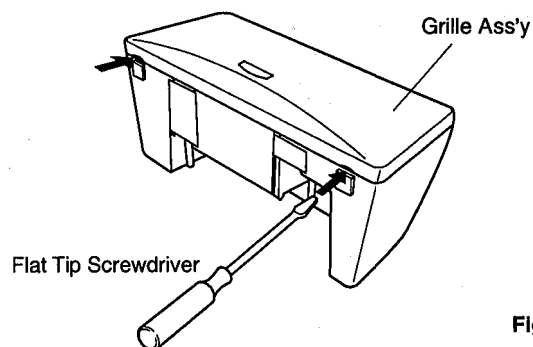

Fig. 5

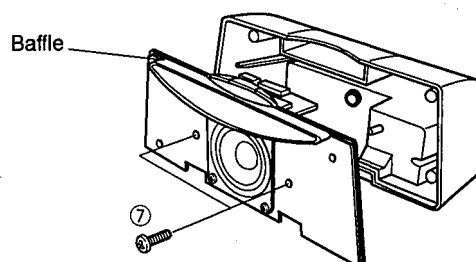

Fig. 6

■ TEST PROGRAM FUNCTION SELECT MODE

1. Procedures for starting & operation

With the power turned off, press the POWER (STANDBY/ON) key while pressing the INPUT key and the PROGRAM key of the NX-AVS7 simultaneously. This initiates the Test Program Function Select mode. Select the test program function No. by using the INPUT keys and then press the POWER key to execute the selected function.

* According to the test program function No., execute the test program mode repeatedly.

2. Content (Function) of the Test Program

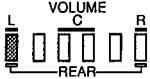
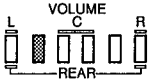
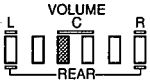
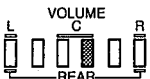
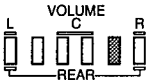
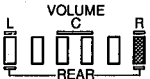
No.	LED display (STANDBY & VOLUME)	Function
01	STANDBY (flashing) + 	Used to check the DSP operation and characteristics. (For more information, refer to the DSP Self-diagnosis Function section on the next page.)
02	STANDBY (flashing) + 	Used to have all LED segments turned ON and to clear the memory. All LED segments light up when the POWER key is pressed. When it is pressed again, the STANDBY/INPUT 1/INPUT 2 LED segments flash for 2 seconds and the power turns off. (The CPU RAM returns to the initialized state.)
03	STANDBY (flashing) + 	Used to check lighting of all LED segments. All LED segments light up when the POWER key is pressed. When it is pressed again, the power turns off. (Canceled)
04	STANDBY (flashing) + 	All channel output function (used with the DSP mode set to [B : □□ PRO LOGIC])
05	STANDBY (flashing) + 	Used to set for VOLUME LED binary display
06	STANDBY (flashing) + 	Used to cancel the test program.

 means that the segment is lit.

CAUTION

Be sure to perform Steps 1 and 2 described at the right before starting the Test Program function No.04.

If started in any DSP mode other than [B : □□ PRO LOGIC], no normal level signal will be output from the speaker when checking the function.

1. Apply a signal to INPUT 1 to change INPUT to INPUT 1.
2. Set the DSP mode to [B : □□ PRO LOGIC].

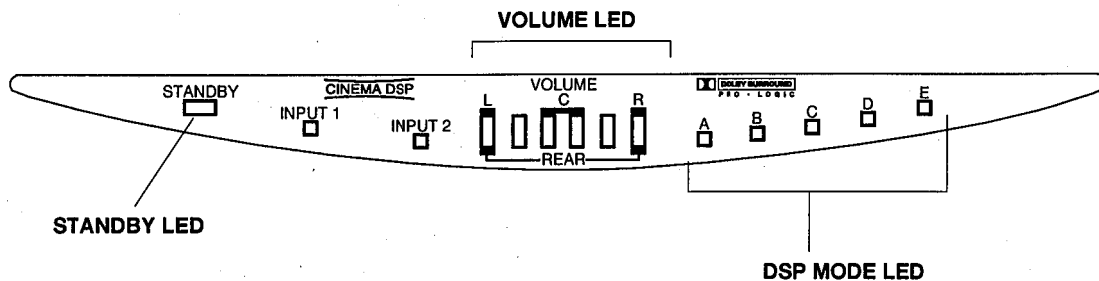

■ DSP SELF-DIAGNOSIS FUNCTION (SELF)

This product has a self-diagnosis function (SELF) to facilitate inspection and measurement of DSP.

Procedures for operation and cancellation

1. Set to the Test Program Function Select mode. (For the mode setting procedure, refer to the TEST PROGRAM FUNCTION SELECT MODE section in the previous page.)
2. Select the Test Program function No.01 and press the POWER key, and the DSP self diagnosis mode (SELF) will be set. The mode setting starts with SELF1.
 - All the DSP MODE LED segments (A ~ E) light up.
 - The function is set to INPUT1. (changeable)
 - The main volume is set to -20dB. (variable)
 - The SUB WOOFER level is set to 0dB. (variable)
3. The diagnosis mode can be set as the table below shows by pressing the DSP PROGRAM keys (A ~ E, OFF) of the remote control unit.

Key	Diagnosis menu (Mode)	VOLUME LED (*1)
A	SELF 1 : RAM THROUGH A	[.]
B	SELF 2 : RAM THROUGH B	[. ]
C	SELF 3 : RAM THROUGH C	[.]
OFF	SELF 4 : DSP OFF	[.]
D	SELF 5 : MANUAL TEST	[.] [.] [. . . .] [. . . .]
E	SELF 6 : PRO LOGIC	[.]

(*1) VOLUME LED (for 5 seconds) quick flashing

4. Turn off the power to cancel the self-diagnosis function (to set back to the normal mode).

• Main volume range (Refer to page 46.)

Note : Due to modification of specifications for the main volume microprocessor, the VOLUME LED lighting pattern of the main volume after modification differs from before modification.

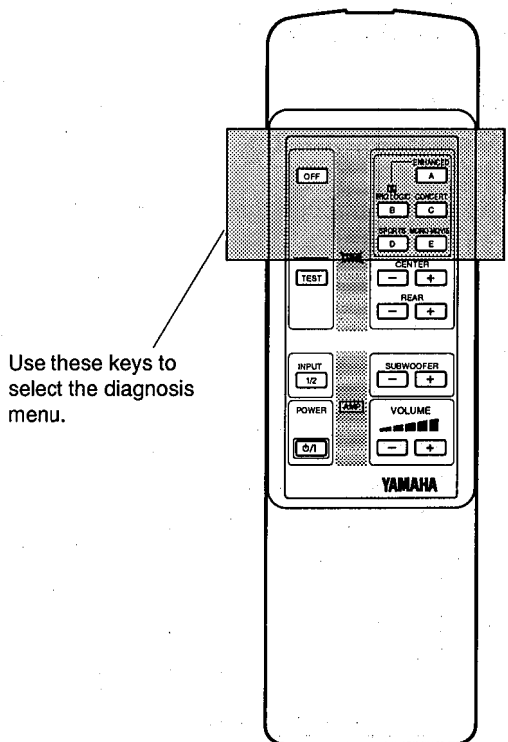

- Note1) The center mode is NORMAL.
 Note2) The electronic /VR (CENTER/REAR) is variable by using the remote control unit.
 Note3) Pressing the TEST key on the remote control unit will change the main volume to MIN (∞) directly.

• SUBWOOFER/CENTER/REAR level range

VOLUME LED	dB	VOLUME LED	dB
[. . . .]	+10	[.]	-6
[. . .]	+9	[. . . .]	-7
[. . . .]	+8	[. . .]	-8
[. . . .]	+7	[. . .]	-9
[. . . .]	+6	[. . .]	-10
[. . . .]	+5	[. . .]	-11
[. . . .]	+4	[. . .]	-12
[. . . .]	+3	[. . .]	-13
[. . . .]	+2	[. .]	-14
[. . . .]	+1	[. .]	-15
[. . . .]	±0	[. .]	-16
[.]	-1	[. .]	-17
[.]	-2	[. .]	-18
[.]	-3	[. .]	-19
[.]	-4	[. .]	-20
[.]	-5		

DETAILS OF SELF CONTENT

SELF 1 RAM THROUGH A

- MAIN L/R is output through the bypass.
- CENTER is output with the steering OFF and by $(L+R)/2$.
- RL/RR passes through the PS-RAM and is output through the DSP.
- The electronic volume (for CENTER/REAR) is 0dB.

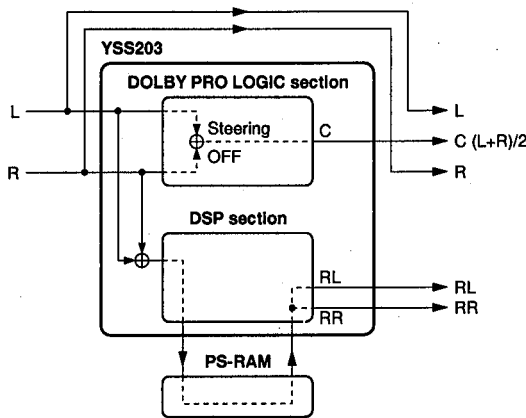

SELF 2 RAM THROUGH B

- L/R and RL/RR pass through the PS-RAM and are output through the DSP.
- CENTER is output with the steering OFF and by $(L+R)/2$.
- The electronic volume (for CENTER/REAR) is -10dB.

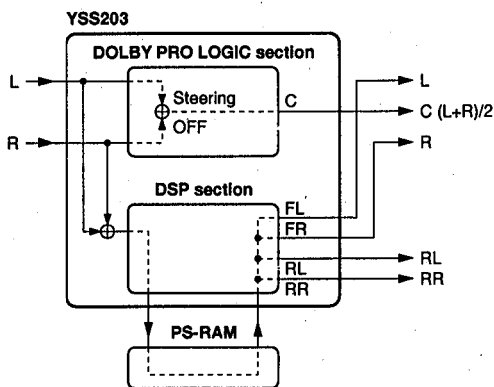

SELF 3 RAM THROUGH C

- L/R is output with the steering OFF.
- CENTER is output with the steering OFF and by $(L+R)/2$.
- RL/RR passes through the PS-RAM and is output through the DSP.
- The electronic volume (for CENTER/REAR) is +10dB.

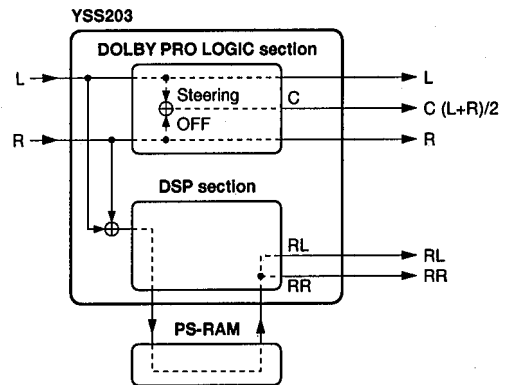

SELF 4 DSP OFF

- EFFECT OFF.

SELF 5 MANUAL TEST

- Every time D key is pressed, the TEST TONE shifts in the order of L→C→R→S and is output.

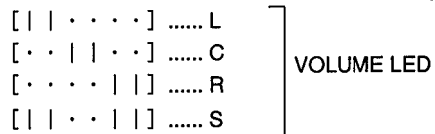

- The electronic volume (for CENTER/REAR) is 0dB.

SELF 6 DOLBY PRO LOGIC

- The auto input balance which is ON in the normal mode is turned OFF.
- The electronic volume (for CENTER/REAR) is 0dB.

NX-AVS7 IC DATA

IC1 : M37471M4-XXXSP (XU723A0 or XU723B0)
8 bit μ -COM

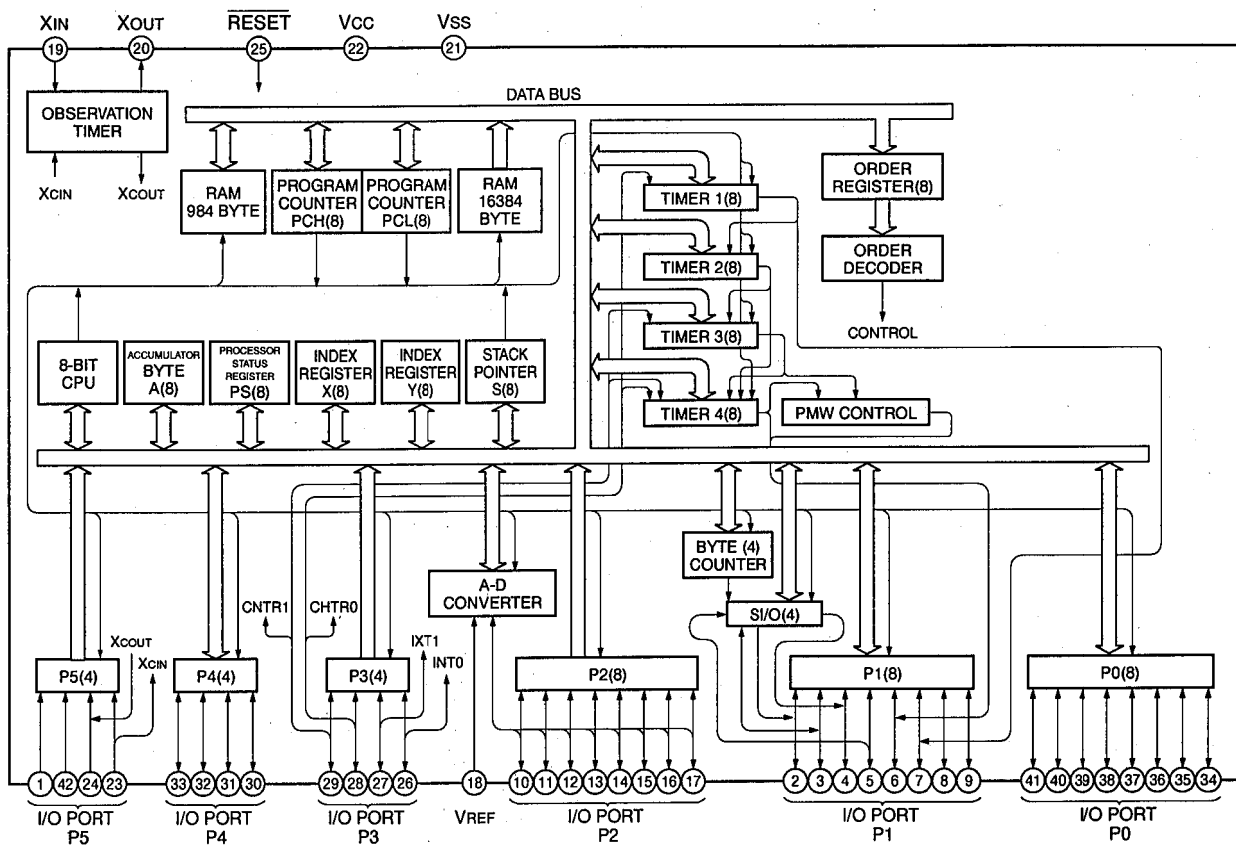
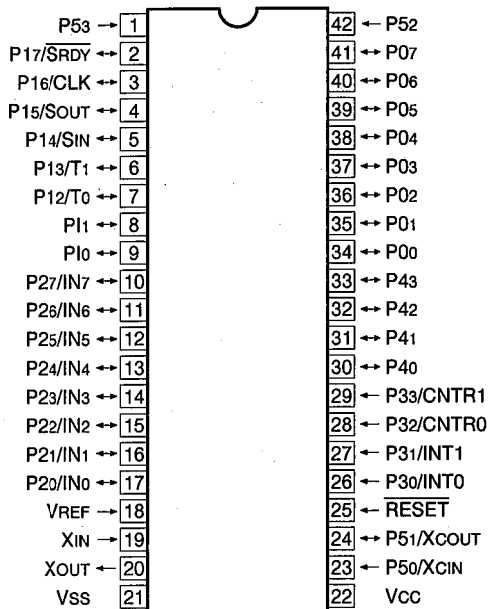

AV-S7

IC1 : M37471M4-XXXSP (XU723A0 or XU723B0)
8 bit μ -COM

No.	Port	Name	I/O	Function
1	P53		I	(pull-down through resistor GND)
2	P17	CE OUT	O	DSP CPU CE OUT [0 : DATA transfer]
3	P16	CLK OUT	O	DSP CPU CLK OUT [CMOS]
4	P15	DATA OUT	O	DSP CPU DATA OUT [CMOS]
5	P14	L-M MOVIE	O	LED OUT MONO MOVIE [1 : LED ON]
6	P13	L-SPORT	O	LED OUT SPORT [1 : LED ON]
7	P12	L-CNCERT	O	LED OUT CONCERT [1 : LED ON]
8	P11	L-ENHNCD	O	LED OUT <input type="checkbox"/> PRO LOGIC ENHANCED [1 : LED ON]
9	P10	L-PLOGIC	O	LED OUT <input type="checkbox"/> PRO LOGIC [1 : LED ON]
10	P27	INP SEL	O	INPUT SELECT OUT [0 : VIDEO-1, 1 : VIDEO-2]
11	P26			(pull-down through resistor GND)
12	P25			(pull-down through resistor GND)
13	P24			(pull-down through resistor GND)
14	P23	MODEL	I	(pull-up through 10k Ω VREF)
15	P22	DEST	I	(pull-up through 10k Ω VREF)
16	P21	KEY 1	I	KEY 1 in (pull-up through 10k Ω VREF)
17	P20	KEY 0	I	KEY 0 in (pull-up through 10k Ω VREF)
18	VREF	VREF		A/D reference voltage in [+ 5V]
19	XIN	XIN		8MHz IN
20	XOUT	XOUT		8MHz OUT
21	VSS	GND		GND
22	VCC	VCC		+ 5V
23	P50		I	(pull-down through resistor GND)
24	P51		I	(pull-down through resistor GND)
25	RES	RESET		RESET [0 : RESET]
26	P30	AC-IN	I	Power down AC pulse in [50/60Hz]
27	P31	REM-IN	I	Remote control in
28	P32		I	(pull-down through resistor GND)
29	P33		I	(pull-down through resistor GND)
30	P40	L-STNDBY	O	LED OUT STANDBY [1 : LED ON]
31	P41	L-INPUT1	O	LED OUT VIDEO-1 [1 : LED ON]
32	P42	L-INPUT2	O	LED OUT VIDEO-2 [1 : LED ON]
33	P43			(pull-down through resistor GND)
34	P00	L-VOLM 0	O	LED OUT VOLUME 0 [.] [1 : LED ON]
35	P01	L-VOLM 1	O	LED OUT VOLUME 1 [. ] [1 : LED ON]
36	P02	L-VOLM 2	O	LED OUT VOLUME 2 [.] [1 : LED ON]
37	P03	L-VOLM 3	O	LED OUT VOLUME 3 [.] [1 : LED ON]
38	P04	L-VOLM 4	O	LED OUT VOLUME 4 [.] [1 : LED ON]
39	P05	L-VOLM 5	O	LED OUT VOLUME 5 [.] [1 : LED ON]
40	P06			(pull-down through resistor GND)
41	P07			(pull-down through resistor GND)
42	P52		I	(pull-down through resistor GND)

● KEY INPUT (A-D) PULL-UP RESISTOR 10k Ω

Ω	0	+2k	+1.8k	+2.4k	+3.9k	+5.6k	+10k	+24k
KEY 0 (17pin)	POWER	PROGRAM	NO KEY	NO KEY	NO KEY	NO KEY	NO KEY	NO KEY
KEY 1 (16pin)	INPUT	NO KEY	NO KEY	NO KEY	NO KEY	NO KEY	NO KEY	NO KEY

■ SW-AVS7 IC DATA

IC413 : M38172M4-195FP
8 bit μ-COM

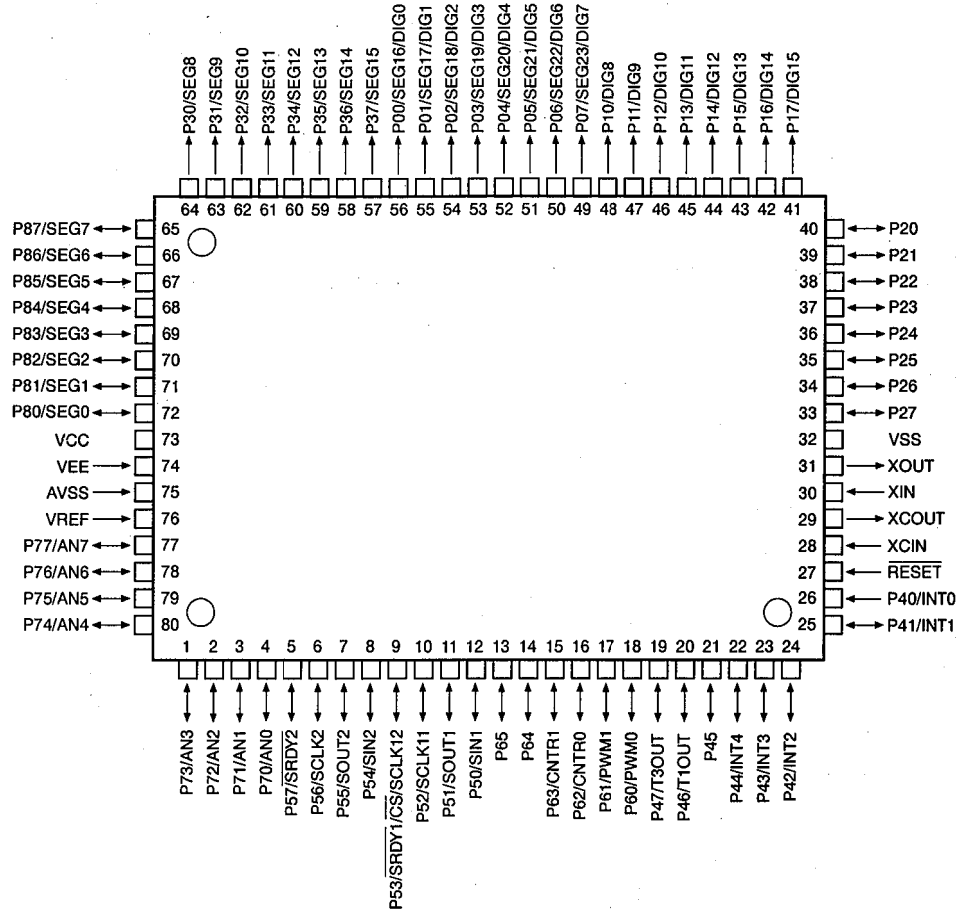

No.	Port	Name	Function
1	P73	SELCE	LC78213 CE OUT
2	P72	DVRCE	Electric controlled volume (DSP) CE OUT [1 : DATA transfer]
3	P71	MVRCE	Electric controlled volume (LC7536) CE OUT [1 : DATA transfer]
4	P70	DSPCE	DSP (YSS203) CE OUT [1 : DATA transfer]
5	P57		(pull-down through resistor GND)
6	P56	DSPCLK	YSS203/LC7536 CLK OUT (Serial I/O2)
7	P55	DSPDAT	YSS203/LC7536 DATA OUT (Serial I/O2)
8	P54		(pull-down through resistor GND) (Serial I/O2)
9	P53	SYSCE	Control data CE IN
10	P52	SYSCLK	Control data CLK IN (Serial I/O1)
11	P51		(pull-down through resistor GND) (Serial I/O1)
12	P50	SYSDAT	Control data DATA IN (Serial I/O1)
13	P65	PREMUT	PRE MUTE
14	P64	SWMUT	SUBWOOFER MUTE
15	P63	PWRON	POWER ON
16	P62	SPRY	SPEAKER RELAY
17	P61	PWRRY	POWER RELAY
18	P60		(pull-down through resistor GND)
19	P47		(pull-down through resistor GND)
20	P46		(pull-down through resistor GND)
21	P45		(pull-down through resistor GND)
22	P44		(pull-down through resistor GND)
23	P43		(pull-down through resistor GND)
24	P42		(pull-down through resistor GND)
25	P41		(pull-down through resistor GND)

AV-S7

IC413 : M38172M4-195FP
8 bit μ -COM

AV-S7

No.	Port	Name	Function
26	P40	ACDTC	Power down AC pulse IN
27	RES	RESET	RESET
28	XCIN		GND (Sub clock)
29	XCOU	NC	Open (Sub clock)
30	XIN	XIN	6.3 MHz IN (Main clock)
31	XOUT	XOUT	6.3 MHz OUT (Main clock)
32	VSS	O-GNG	GND
33	P27	EX7	(Extension-7) (Not used)
34	P26	EX6	(Extension-6) (Not used)
35	P25	EX5	(Extension-5) (Not used)
36	P24	EX4	(Extension-4) (Not used)
37	P23	EX3	(Extension-3) (Not used)
38	P22	EX2	(Extension-2) (Not used)
39	P21	EX1	(Extension-1) (Not used)
40	P20	EX0	(Extension-0) (Not used)
41	P17	NC	Open
42	P16	NC	Open
43	P15	NC	Open
44	P14	NC	Open
45	P13	NC	Open
46	P12	NC	Open
47	P11	NC	Open
48	P10	NC	Open
49	P07	NC	Open
50	P06	NC	Open
51	P05	NC	Open
52	P04	NC	Open
53	P03	NC	Open
54	P02	NC	Open
55	P01	NC	Open
56	P00	NC	Open
57	P37	NC	Open
58	P36	NC	Open
59	P35	NC	Open
60	P34	NC	Open
61	P33	NC	Open
62	P32	NC	Open
63	P31	NC	Open
64	P30	NC	Open
65	P87		(pull-down through resistor GND)
66	P86		(pull-down through resistor GND)
67	P85		(pull-down through resistor GND)
68	P84		(pull-down through resistor GND)
69	P83		(pull-down through resistor GND)
70	P82		(pull-down through resistor GND)
71	P81		(pull-down through resistor GND)
72	P80	PROTEC	PROTECTION
73	VCC	5V	+5V
74	VEE		GND
75	AVSS		GND
76	VREF		GND
77	P77		(pull-down through resistor GND) (A-D)
78	P76		(pull-down through resistor GND) (A-D)
79	P75		(pull-down through resistor GND) (A-D)
80	P74		(pull-down through resistor GND) (A-D)

IC416 : YSS203B

Digital Dolby Pro Logic Decoder with Auto Input Balance

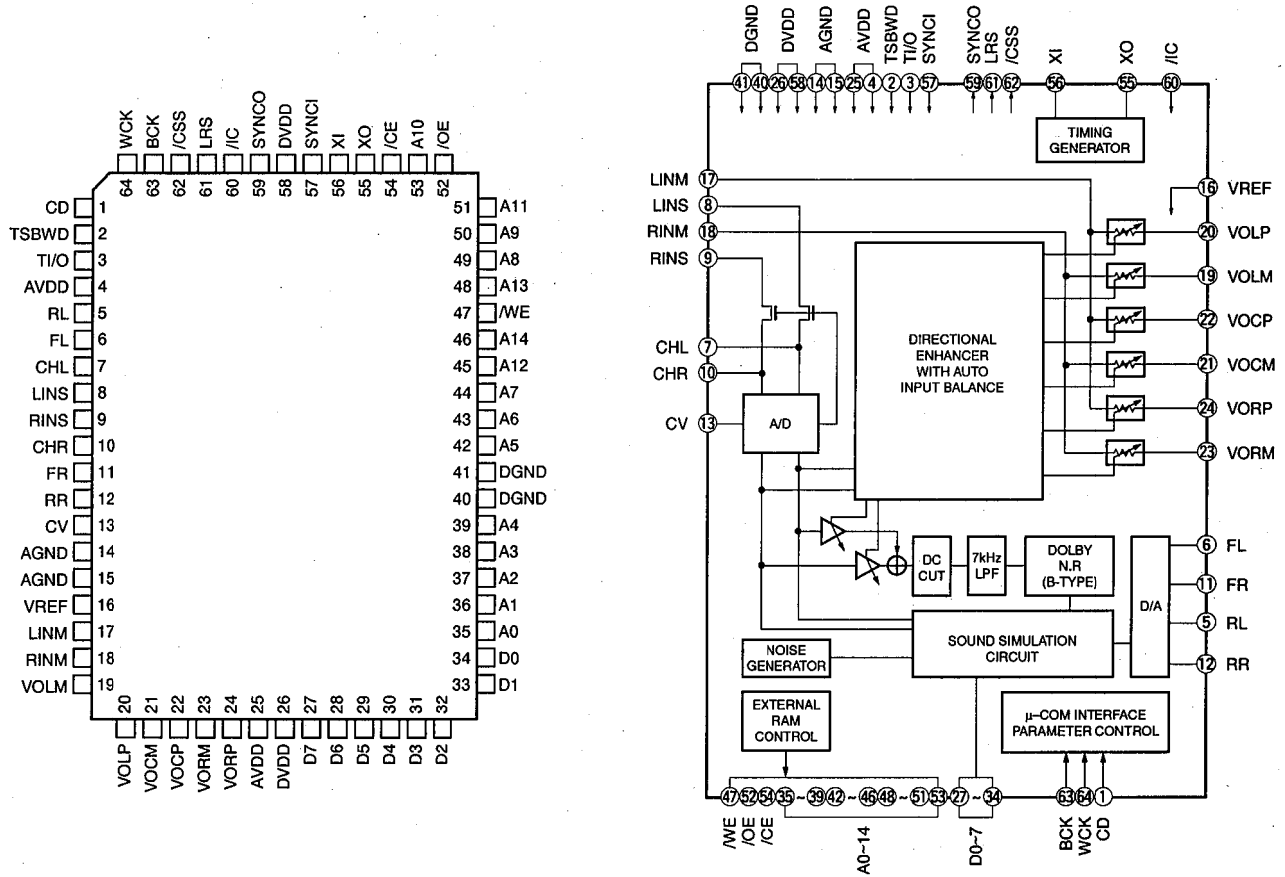

No.	Name	I/O	Function
1	CD	I/O	Serial data of parameter data input
2	TSBWD	Ic	LSI test terminal Normally connected to DVDD terminal
3	TI/O	Ic	LSI test terminal Normally connected to DVDD terminal
4	AVDD	A—	+5V power supply (D/A, A/D section)
5	RL	AO	RL channel D/A output
6	FL	AO	FL channel D/A output
7	CHL	A—	LINS input Sample/hold Capacitor external terminal
8	LINS	AI	L channel A/D input
9	RINS	AI	R channel A/D input
10	CHR	A—	RINS input Sample/hold Capacitor external terminal
11	FR	AO	FR channel D/A output
12	RR	AO	RR channel D/A output
13	CV	AO	A/D, multiplying DAC center voltage
14	AGND	A—	Ground (D/A, A/D section)
15	AGND	A—	Ground (Multiplying DAC section)
16	VREF	AI	Multiplying DAC reference voltage input
17	LINM	AI	L channel Multiplying DAC input
18	RINM	AI	R channel Multiplying DAC input
19	VOLM	AO	L channel operation amplifier, connected to (-) terminal
20	VOLP	AO	L channel operation amplifier, connected to (+) terminal

AV-S7

IC416 : YSS203B

Digital Dolby Pro Logic Decoder with Auto Input Balance

No.	Name	I/O	Function
21	VOCM	AO	C channel operation amplifier, connected to (-) terminal
22	VOCP	AO	C channel operation amplifier, connected to (+) terminal
23	VORM	AO	R channel operation amplifier, connected to (-) terminal
24	VORP	AO	R channel operation amplifier, connected to (+) terminal
25	AVDD	A—	+5V power supply (multiplying DAC section)
26	DVDD	—	+5V power supply (digital section)
27	D7	I/Ot	External delay RAM data terminal
28	D6	I/Ot	External delay RAM data terminal
29	D5	I/Ot	External delay RAM data terminal
30	D4	I/Ot	External delay RAM data terminal
31	D3	I/Ot	External delay RAM data terminal
32	D2	I/Ot	External delay RAM data terminal
33	D1	I/Ot	External delay RAM data terminal
34	D0	I/Ot	External delay RAM data terminal
35	A0	O	External data RAM address terminal
36	A1	O	External data RAM address terminal
37	A2	O	External data RAM address terminal
38	A3	O	External data RAM address terminal
39	A4	O	External data RAM address terminal
40	DGND	—	Ground (digital section)
41	DGND	—	Ground (digital section)
42	A5	O	External data RAM address terminal
43	A6	O	External data RAM address terminal
44	A7	O	External data RAM address terminal
45	A12	O	External data RAM address terminal
46	A14	O	External data RAM address terminal
47	/WE	O	External delay RAM write enable terminal
48	A13	O	External delay RAM address terminal
49	A8	O	External delay RAM address terminal
50	A9	O	External delay RAM address terminal
51	A11	O	External delay RAM address terminal
52	/OE	O	External delay RAM output enable terminal
53	A10	O	External delay RAM address terminal
54	/CE	O	External delay RAM chip enable terminal
55	XO	O	Crystal oscillator connecting terminal
56	XI	I	Crystal oscillator connecting terminal
57	SYNCI	It	Test terminal for system synchronization, normally connected to DVDD
58	DVDD	—	+5V power supply (digital section)
59	SYNCO	O	Test terminal for system synchronization, normally unconnected
60	/IC	Ics	Initial clear terminal (Power ON resetting is necessary)
61	LRS	O	External automatic input balance terminal, normally unconnected
62	/CSS	O	External automatic input balance terminal, normally unconnected
63	BCK	I _{ts}	Bit clock for parameter data input
64	WCK	I _{ts}	Word clock for parameter data input

Note : Letters used in the above I/O column represent as follows.

I : Input terminal O : Output terminal t : TTL level
c : CMOS level s : Schmitt input A : Analog terminal

■ BLOCK DIAGRAM / ブロックダイアグラム

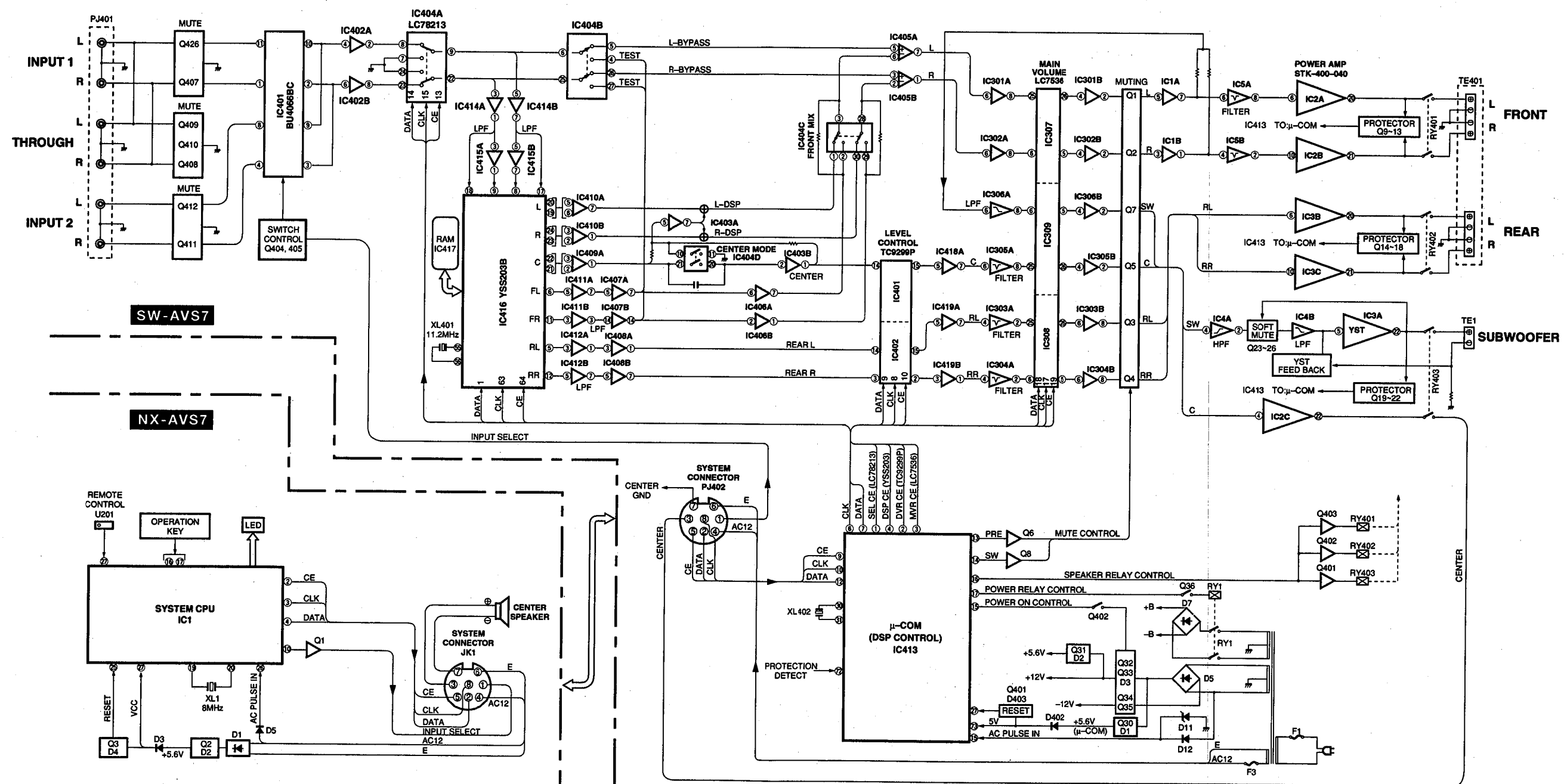

1
2
3
4
5
6

■ NX-AVS7 PRINTED CIRCUIT BOARD / シート ☒

P. C. B. MAIN (1) (Component side)

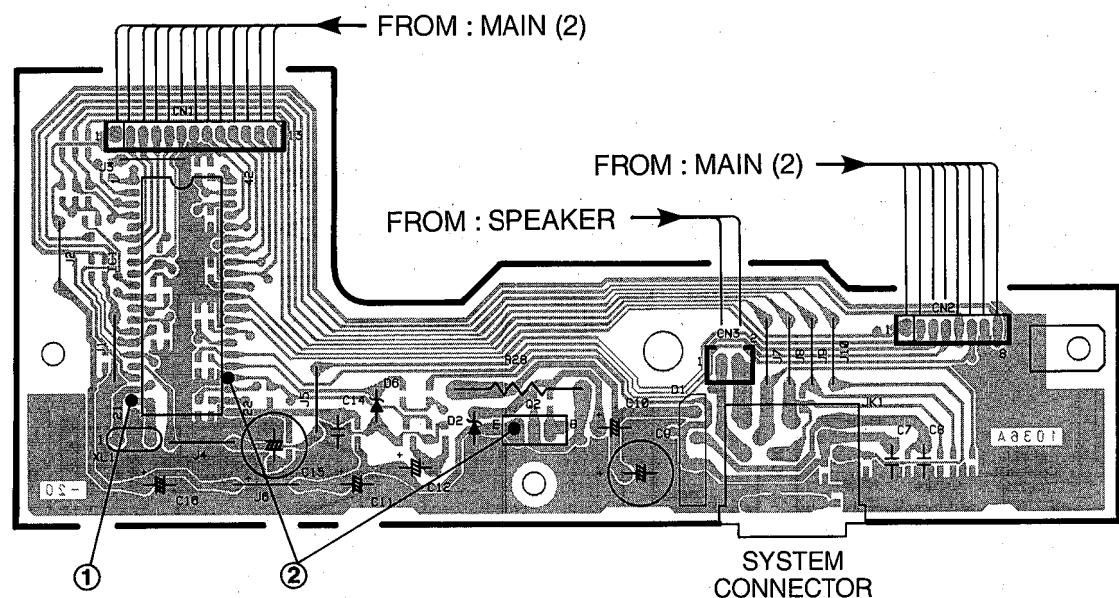

Point ① (Pin20 of IC1)
 V : 2V/div H : 0.1 μsec/div
 DC range 1 : 1 probe

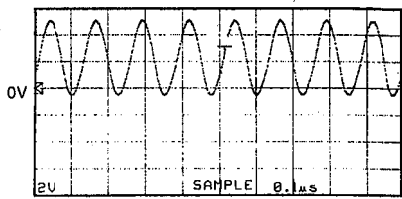

Point ②
 (CH 1 : Pin25 of IC1 CH 2 : Emitter of Q2)
 V : 2V/div (CH 1) V : 2V/div (CH 2)
 H : 0.5 sec/div DC range 1 : 1 probe

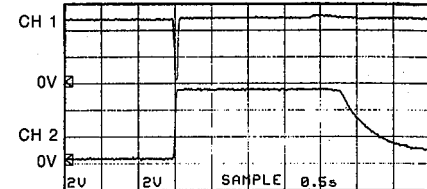

P. C. B. MAIN (1) (Foil side)

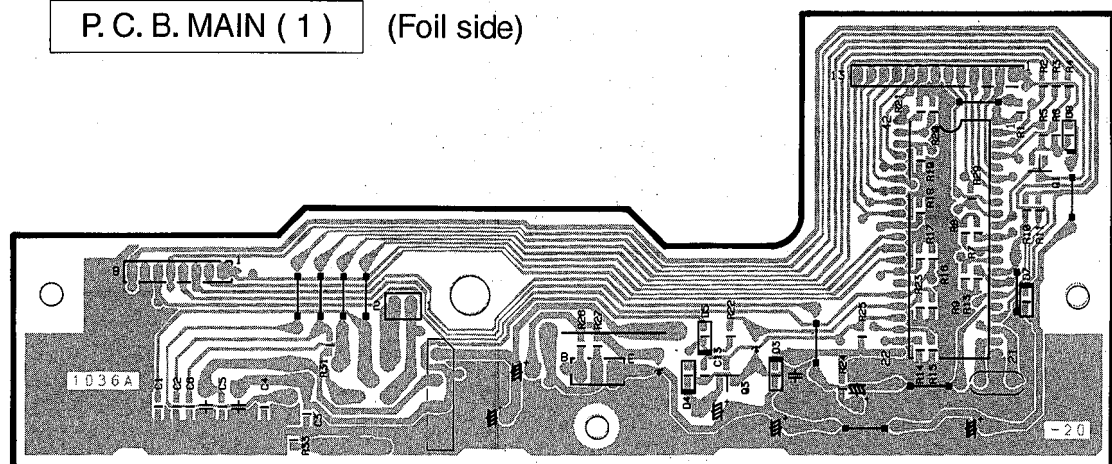

P. C. B. MAIN (2) (Component side)

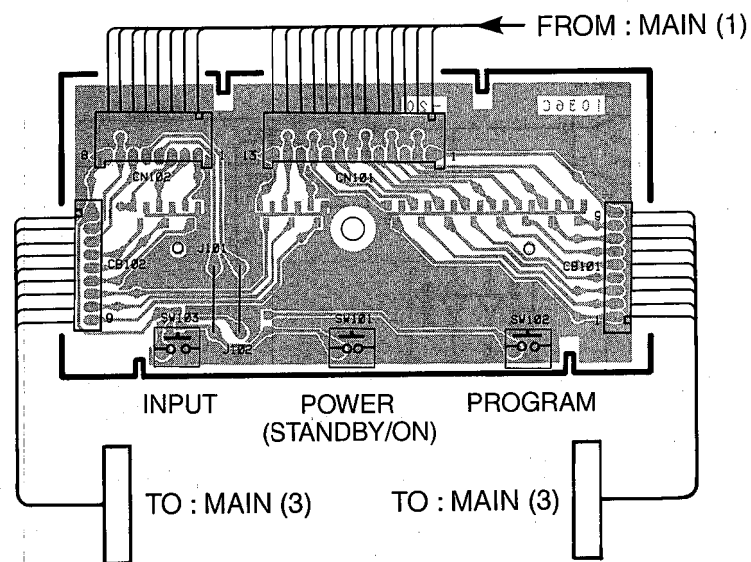

P. C. B. MAIN (2) (Foil side)

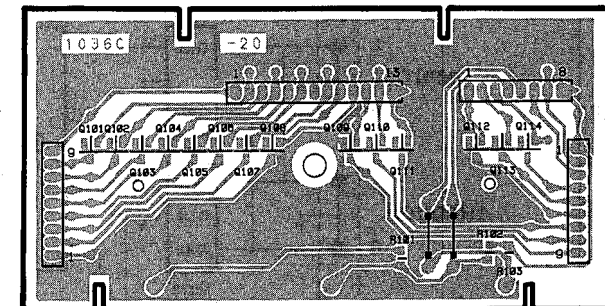

P. C. B. MAIN (3) (Component side)

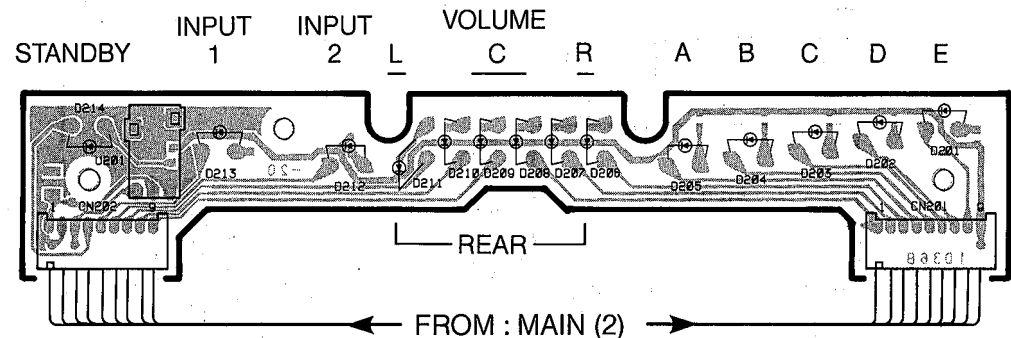

P. C. B. MAIN (3) (Foil side)

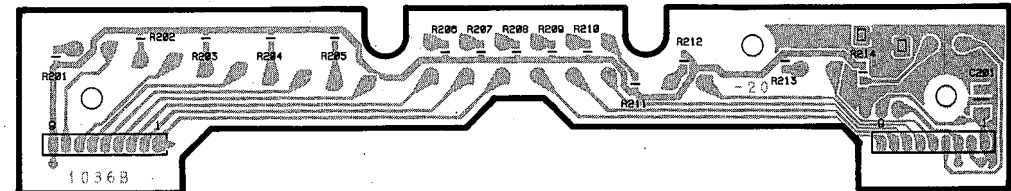

SW-AVS7 PRINTED CIRCUIT BOARD (Foil side) / シート図 (パターン側)

1

Precaution for IC418

When replacing the IC418, be sure to cut the No.1 pin of the new IC418 (μ PD4570G2) first.

IC418の注意

IC418を交換する際、新しいIC418(μ PD4570G2)の1番ピンを必ずリードカットして取り付けてください。

2

Point ③ (Pin31 of IC413)
V : 2V/div H : 50 nsec/div
DC range 1 : 1 probe

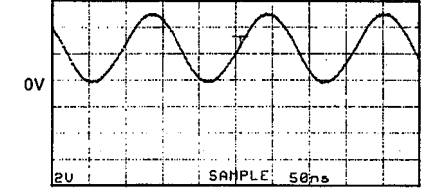

Point ④ (Pin55 of IC416)
V : 2V/div H : 50 nsec/div
DC range 1 : 1 probe

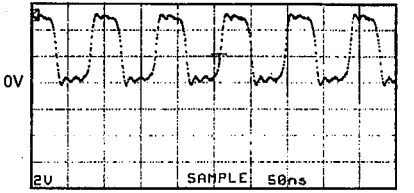

3

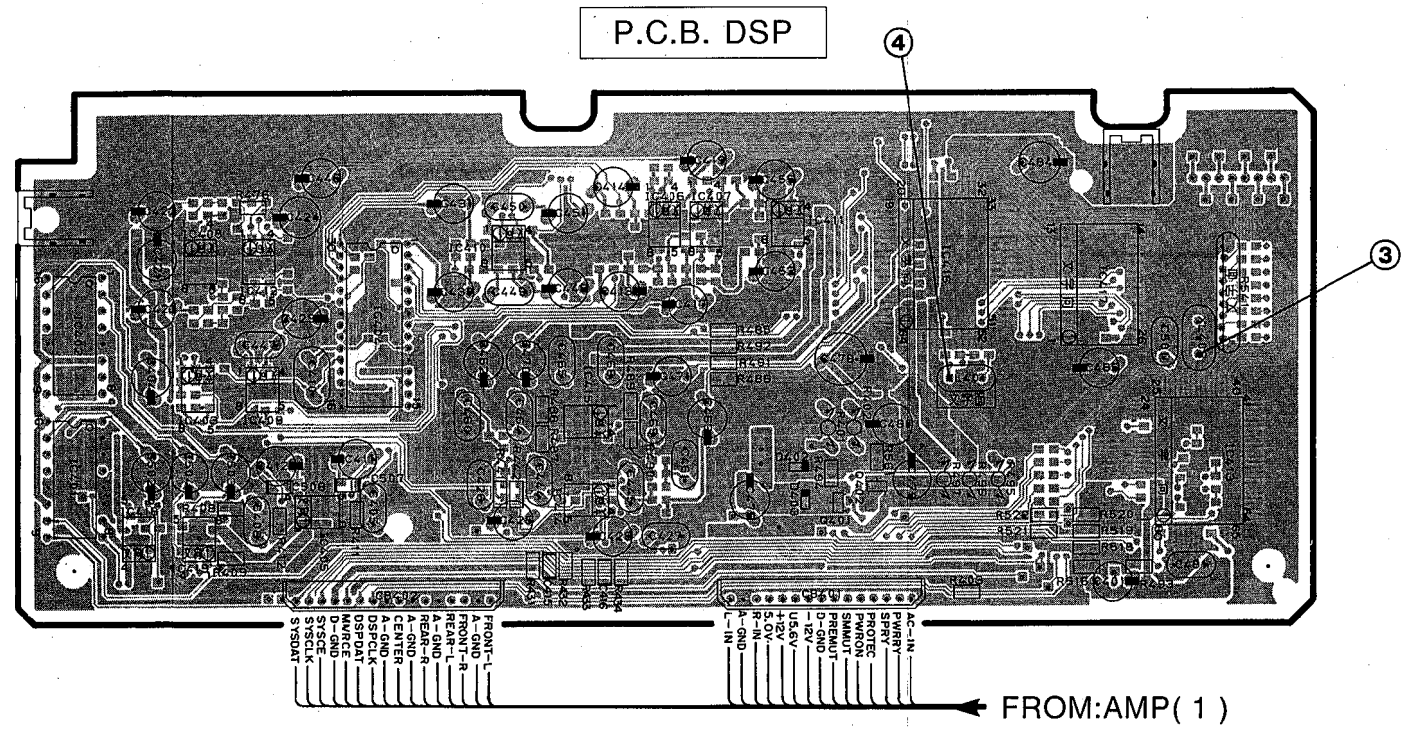

• SERVICE TOOL FOR PCB DSP (P/No. TX946280)
Shown below is the Service Tool (additional PCB) used for operation check of P.C.B. DSP.

• サービス治具 (P/No. TX946280)
P.C.B. DSPの動作チェック用に下図の治具 (延長基板) があります。

4

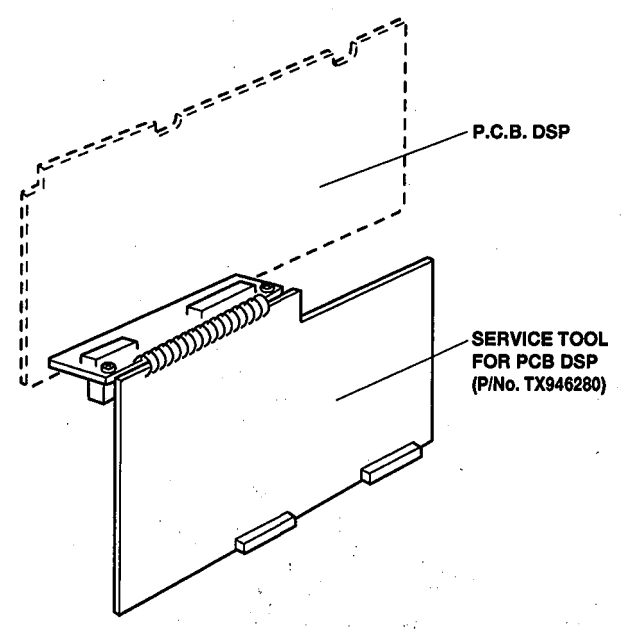

5

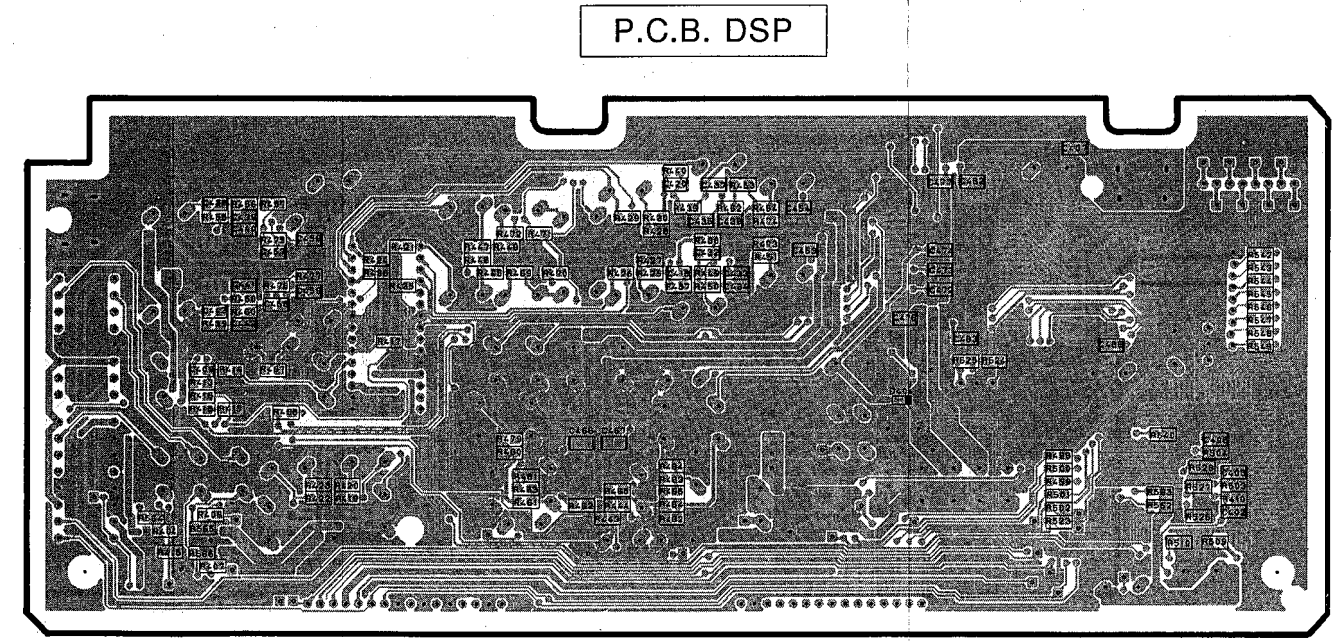

6

SW-AVS7 PRINTED CIRCUIT BOARD (Foil side) / シート図 (パターン側)

1
2
3
4
5
6

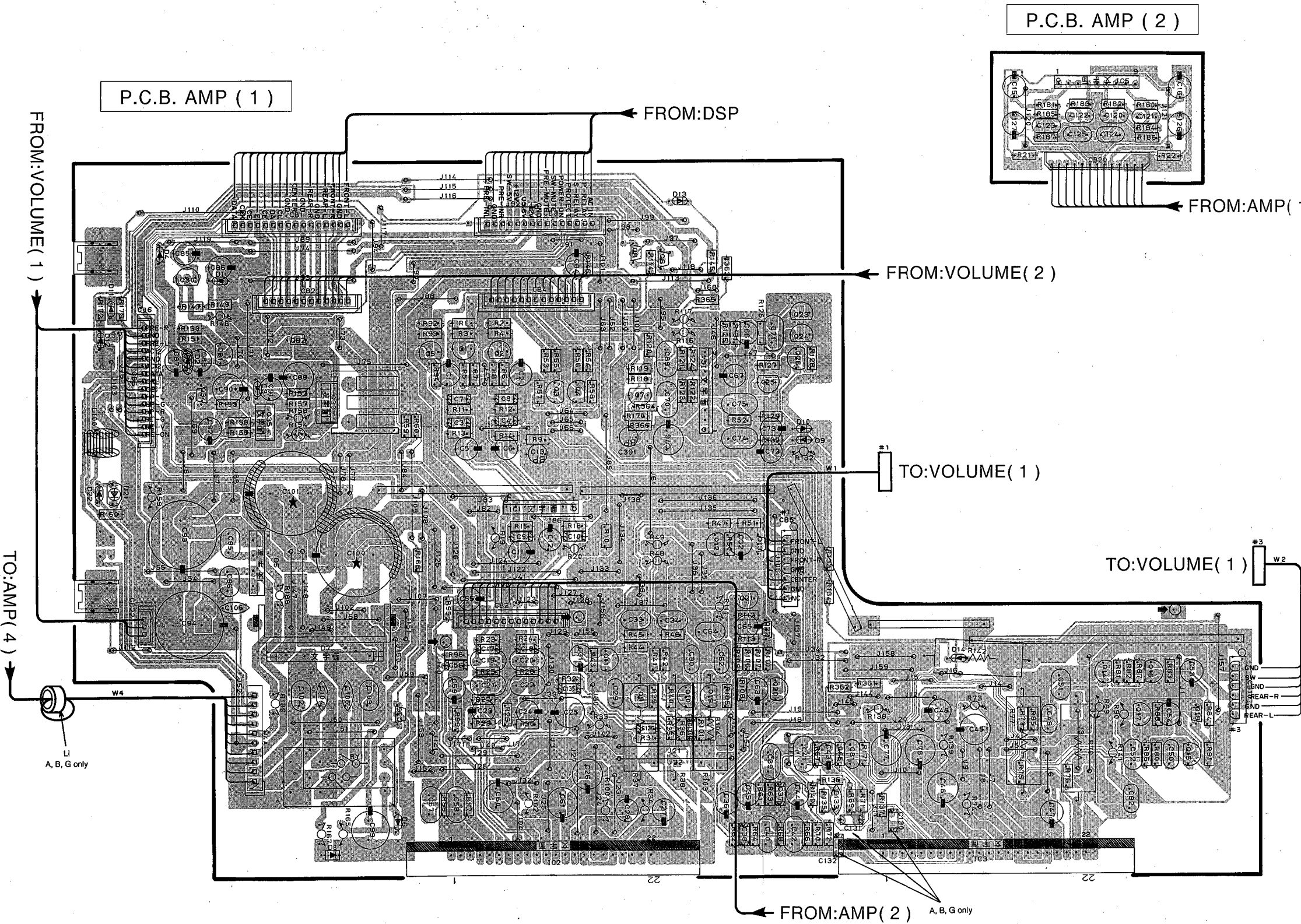

P.C.B. AMP (1)

P.C.B. AMP (2)

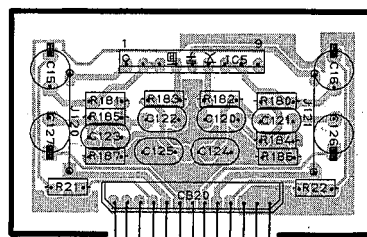

P.C.B. AMP (3)

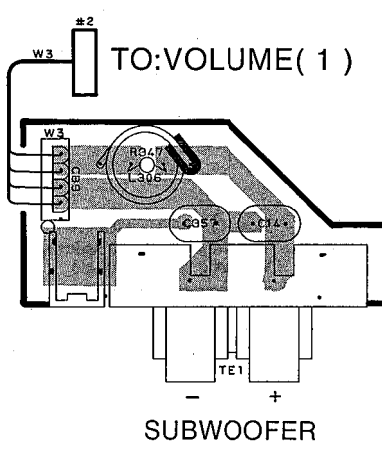

SW-AVS7 PRINTED CIRCUIT BOARD (Foil side) / シート図 (パターン側)

1

P.C.B. VOLUME (1)

P.C.B. VOLUME (2)

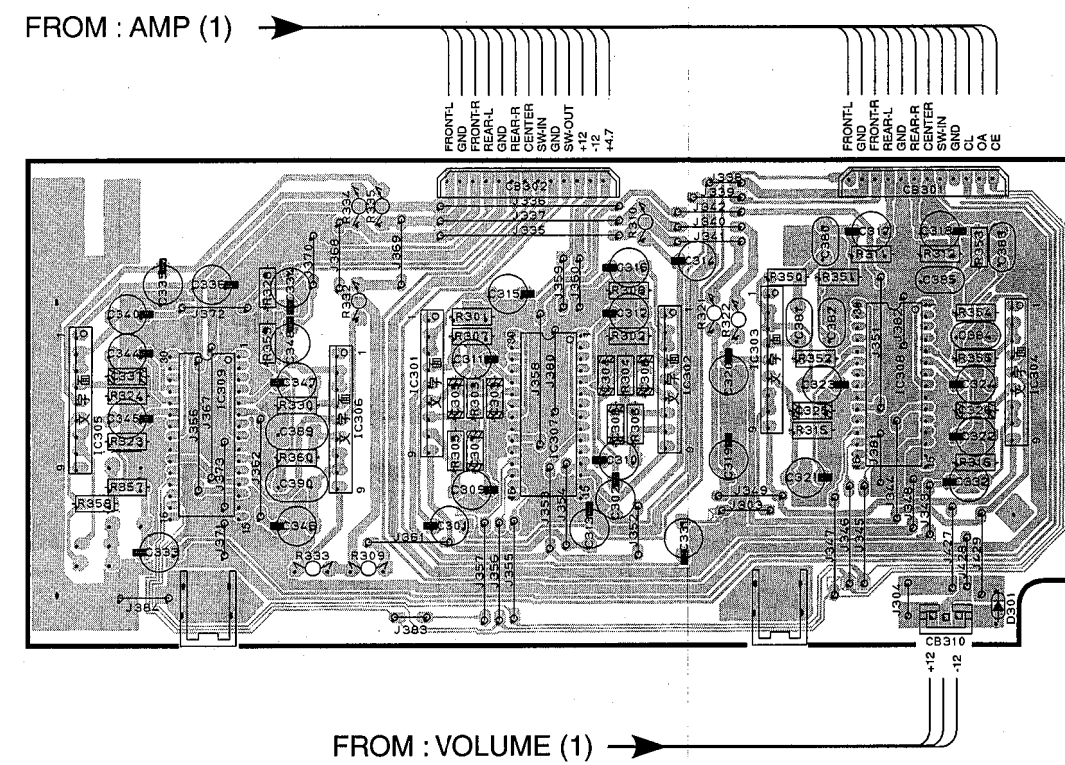
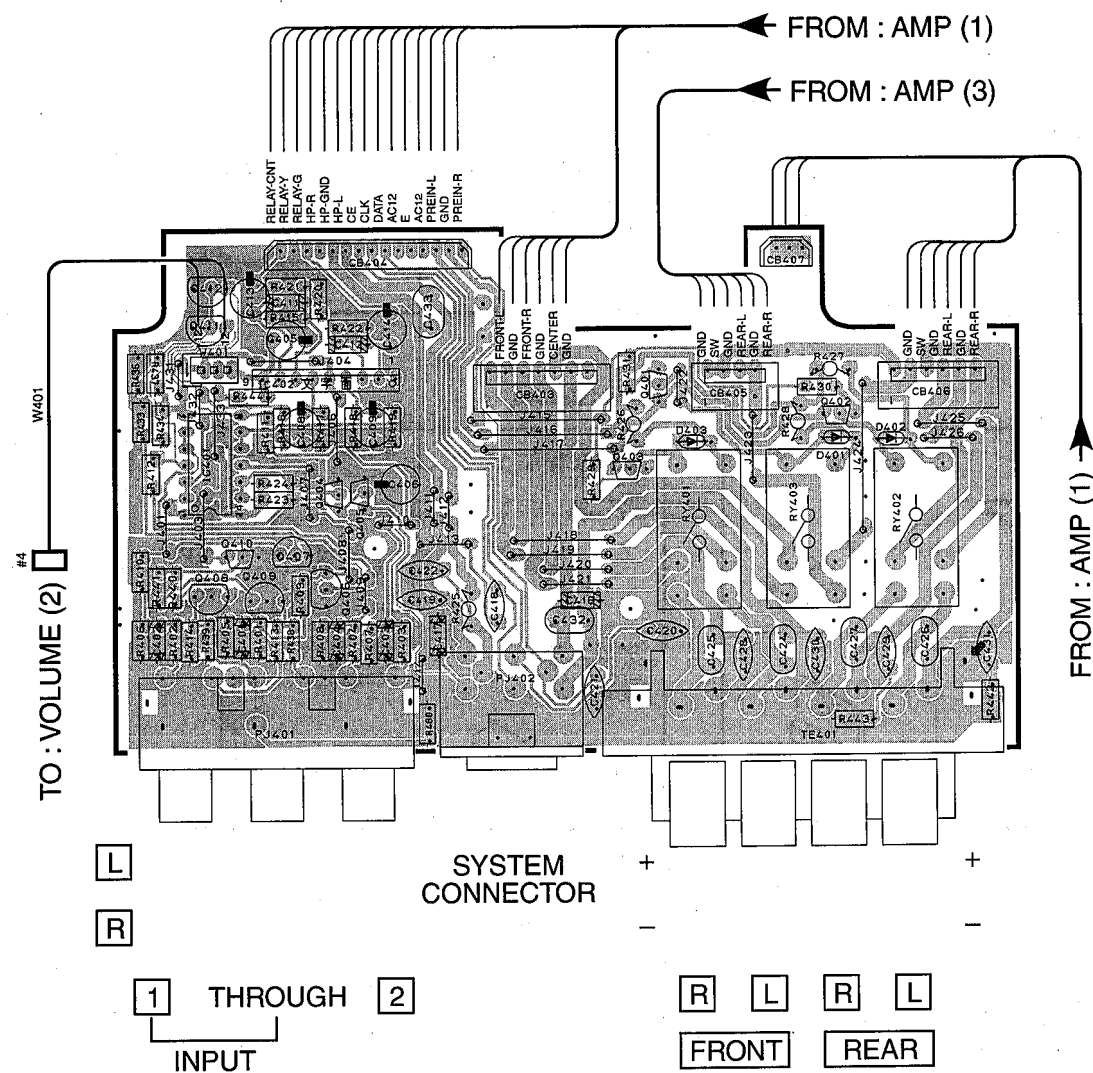

2

3

4

5

6

SW-AVS7 PRINTED CIRCUIT BOARD (Foil side) / シート図 (パターン側)

P.C.B. AMP (4)

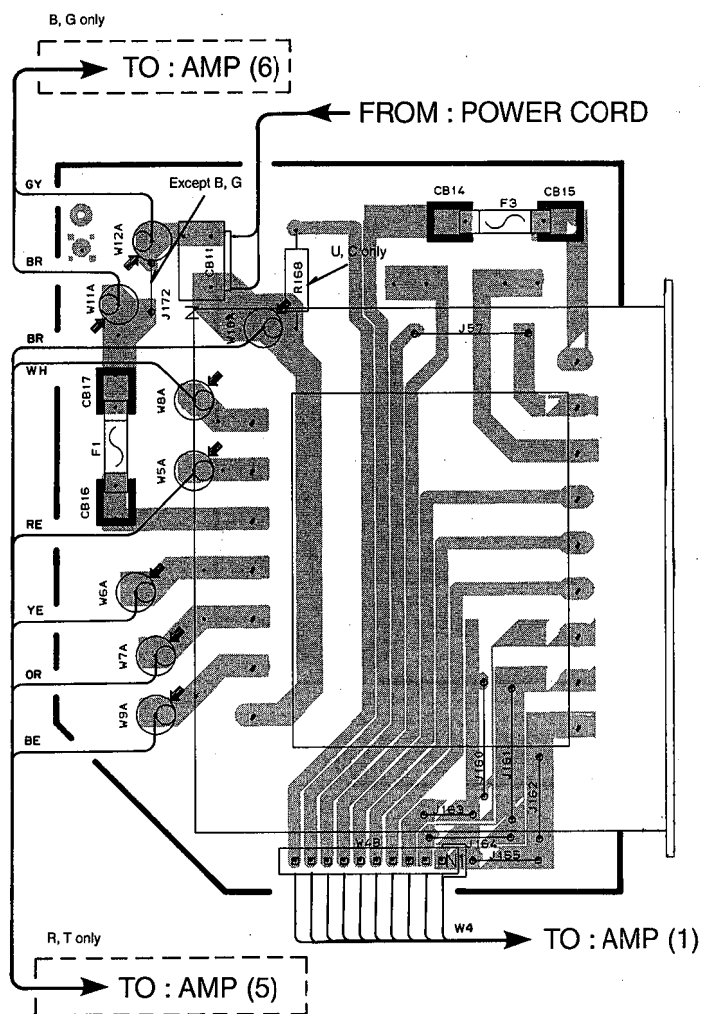

● B, G only

P.C.B. AMP (6)

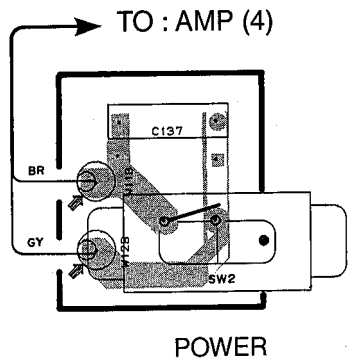

● R, T only

P.C.B. AMP (5)

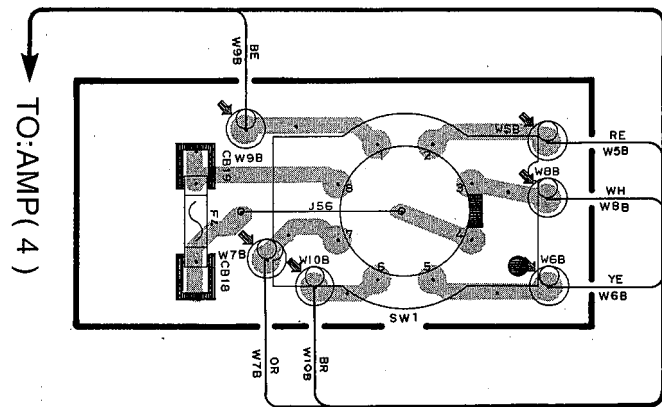

VOLTAGE SELECTOR

SW1	
110V	1-2/5-6
120V	2-3/6-7
240V	3-4/7-8
220V	4-5/8-1

■ PIN CONNECTION DIAGRAM / 半導体外形図

● ICs

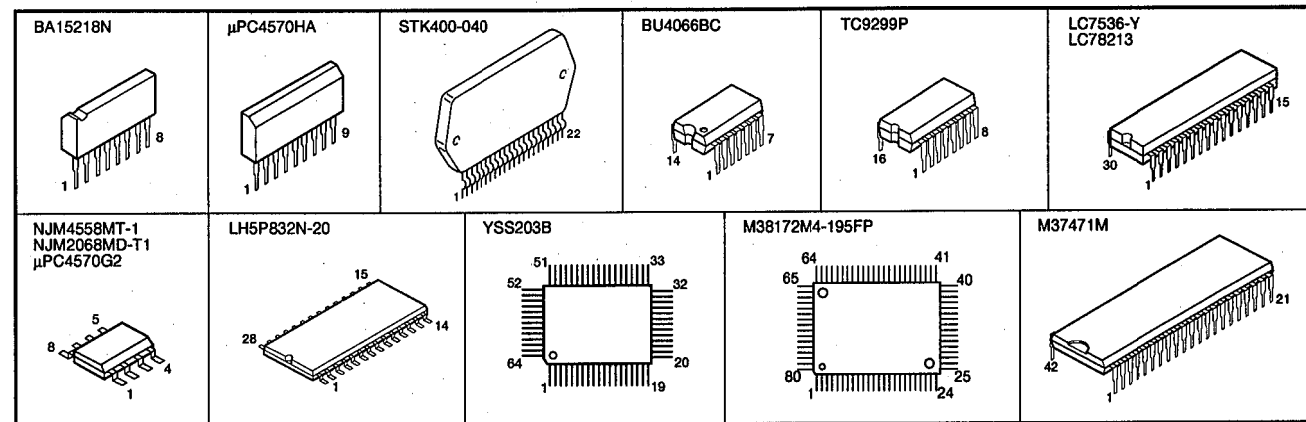

● Diodes

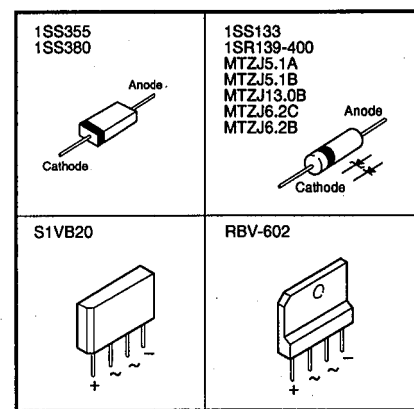

● Transistors

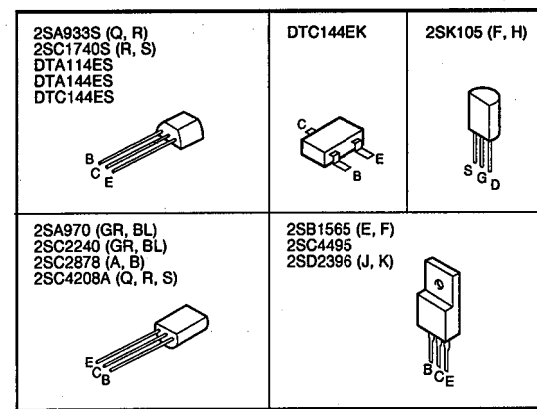

SW-AVS7 (AMP & VOLUME) SCHEMATIC DIAGRAM / 総回路図

RESISTOR

REMARKS	PARTS NAME
NO MARK	CARBON FILM RESISTOR (P-5)
△	CARBON FILM RESISTOR (P-10)
○	METAL OXIDE FILM RESISTOR
△	METAL FILM RESISTOR
□	METAL PLATE RESISTOR
◇	FILTR-PROOF CARBON FILM RESISTOR
○	CEMENT WOUND RESISTOR
◇	SEMI-VARIABLE RESISTOR
■	CHIP RESISTOR

CAPACITOR

REMARKS	PARTS NAME
NO MARK	ELECTROLYTIC CAPACITOR
□	TANTALUM CAPACITOR
○	CERAMIC CAPACITOR
⊗	CERAMIC TUBULAR CAPACITOR
◇	POLYESTER FILM CAPACITOR
○	POLYSTYRENE FILM CAPACITOR
◇	MICA CAPACITOR
○	NON-VISCOUS FILM CAPACITOR
●	SEMICONDUCTIVE CERAMIC CAPACITOR

NOTICE (mode1)
 (J)..... JAPANESE
 (U)..... U.S.A
 (C)..... CANADIAN
 (R)..... GENERAL
 (A)..... AUSTRALIAN
 (B)..... BRITISH
 (G)..... GERMANY
 (T)..... CHINA
 (L)..... SINGAPORE

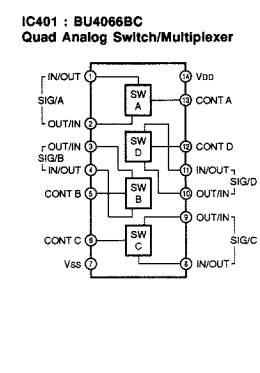
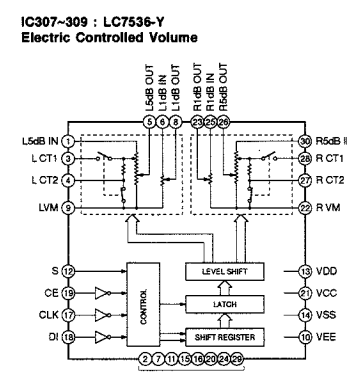
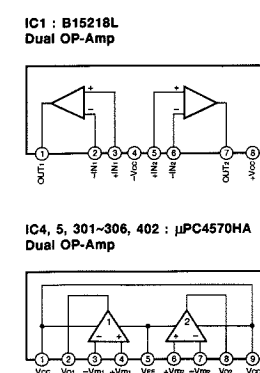

Interchangeable Parts at Manufacture Stage

Mark	Reference Parts Number	Parts Name
41	04-S-9-10-10-13-22	RES104
	301-401-403	RES103
		RES176

CIRCUIT CHANGES BY MARKET

	J	U	C	R.T	A	B.S
1	R156	X	X	X	X	X
2	F1	44125V	44125V	44125V	T1-25AL250V	T1-25AL250V
3	F3	Y35020	Y35020	Y35020	X30077	X30077
4	T1	X3002	X3002	X3002	X3005	X3005
5	SW1	X	X	X	Y48510	X
6	F4	X	X	X	T1-25AL250V	X
7	C130-132	X	X	X	100P	100P
8	CB2	X	X	X	X	X
9	R4	Y22810	Y22810	Y22810	Y22810	Y22810
10	R71	Y27260	Y27260	Y27260	Y27260	Y27260

X: NOT USED

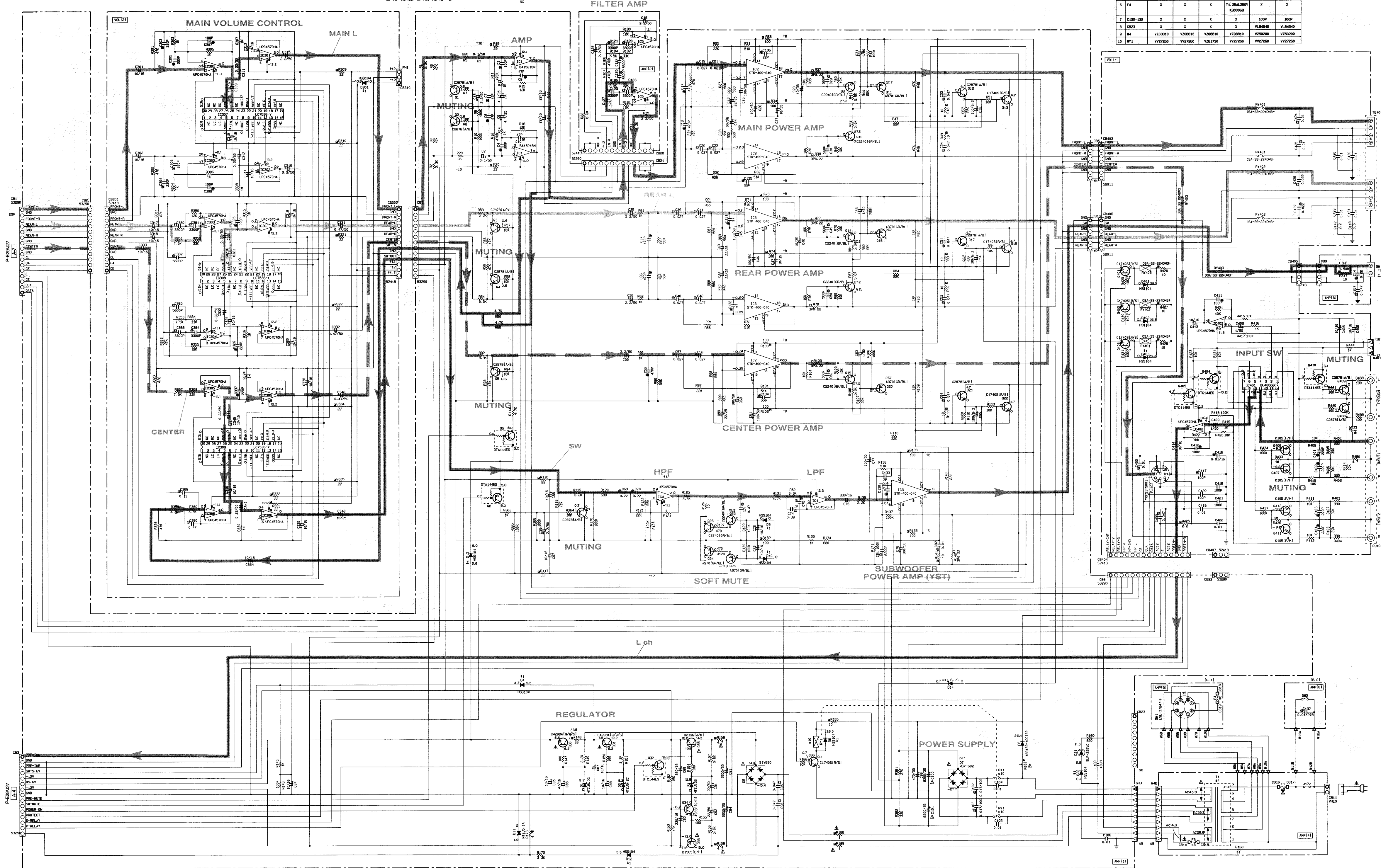

• All voltages are measured with a 10MΩ/V DC electric volt meter.
 • Components having special characteristics are marked △ and must be replaced with parts having specifications equal to those originally installed.
 • Schematic diagram is subject to change without notice.

● 電圧は、内部抵抗10MΩの電圧計で測定したものです。
 ● △印のある部品は、安全性確保部分を示しています。部品の交換が必要な場合、パーツリストに記載されている部品を使用してください。
 ● 本回路図は、標準回路図です。改良のため予告なく変更することがあります。

SW-AVS7 (DSP)/NX-AVS7 SCHEMATIC DIAGRAM/総回路図

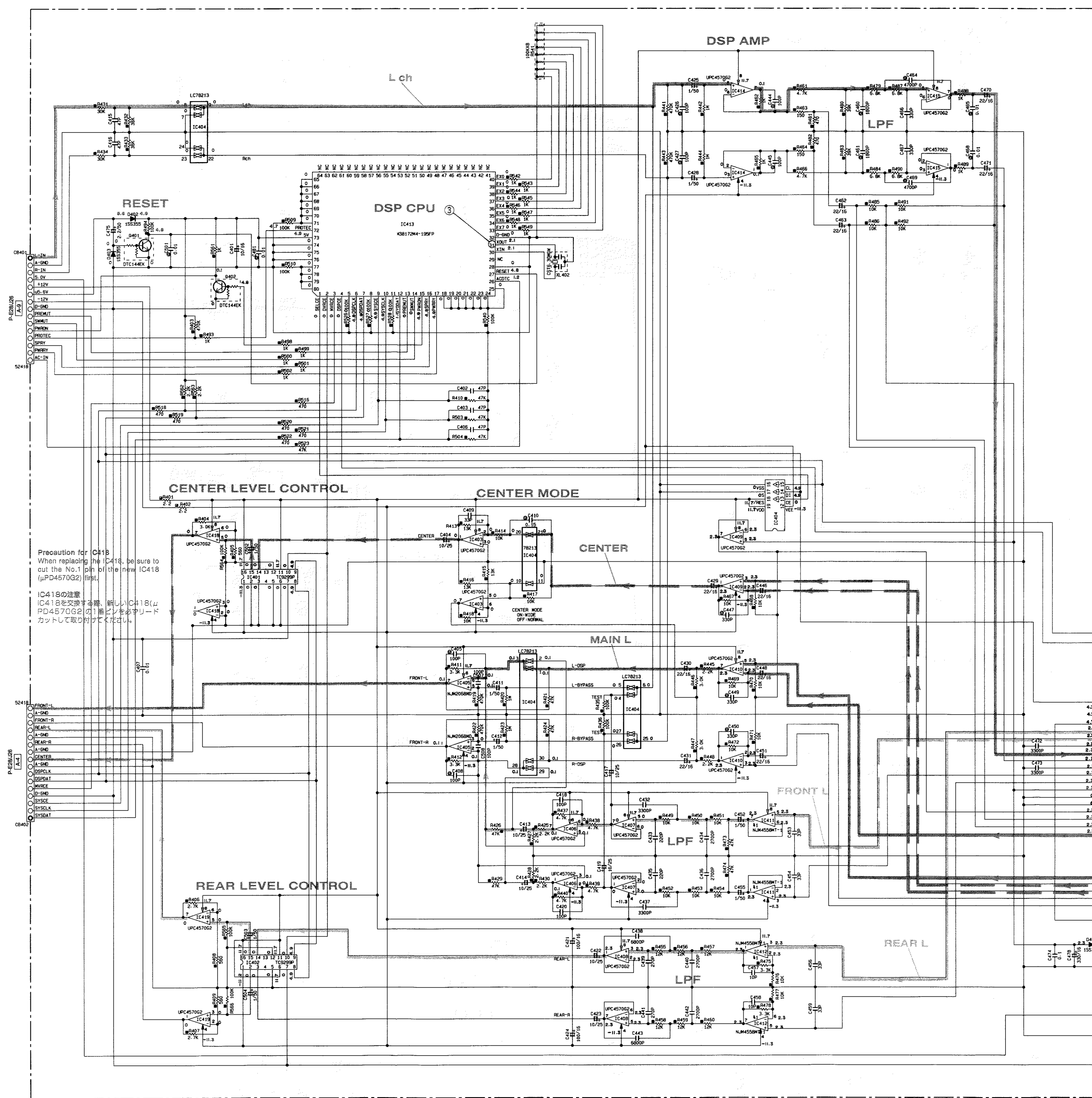
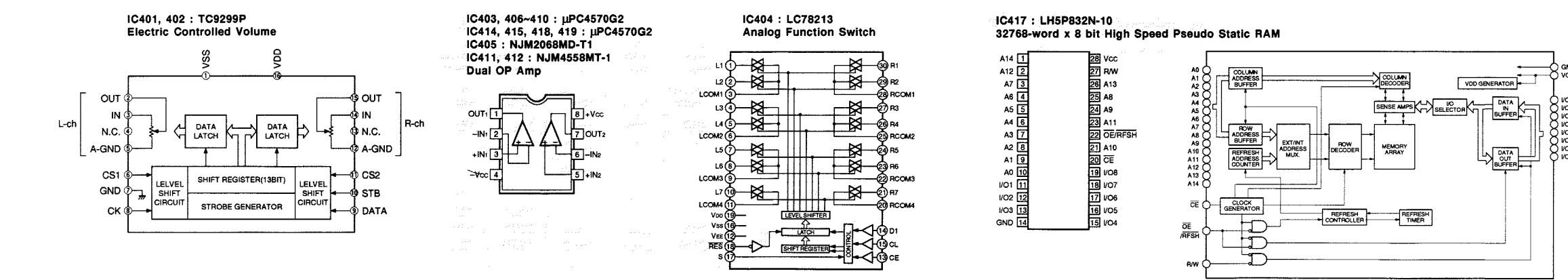

RESISTOR

REMARKS	PARTS NAME	FF
ND MARK	CARBON FILM RESISTOR (F15)	
—	CARBON FILM RESISTOR (F15)	
A	METAL OXIDE FILM RESISTOR	
Δ	METAL FILM RESISTOR	
□	METAL PLATE RESISTOR	
○	FILM GROUP CARBON FILM RESISTOR	
□	CEMENT MOUNTED RESISTOR	
●	TRIMMABLE RESISTOR	
○	CHIP RESISTOR	

CAPACITOR

REMARKS	PARTS NAME	FF
ND MARK	ELECTROLYTIC CAPACITOR	
○	TANTALUM CAPACITOR	
ND MARK	CERAMIC CAPACITOR	
○	CERAMIC SUBSTRATE CAPACITOR	
○	POLYESTER FILM CAPACITOR	
○	POLYSTYRENE FILM CAPACITOR	
○	MICA CAPACITOR	
○	POLYPROPYLENE FILM CAPACITOR	
●	SEMICONDUCTIVE CERAMIC CAPACITOR	

NOTICE (mode1)

(J)..... JAPANESE
(U)..... U. S. A.
(C)..... CANADIAN
(F)..... GENERAL
(A)..... AUSTRALIAN
(S)..... BRITISH
(G)..... EUROPEAN
(T)..... CHINA
(L)..... SINGAPORE

Interchangeable Parts at Manufacture Stage

REMARKS	PARTS NUMBER	PARTS NAME
△	IC411, 412	NJM4558MT-1
		NJM2058MD-1

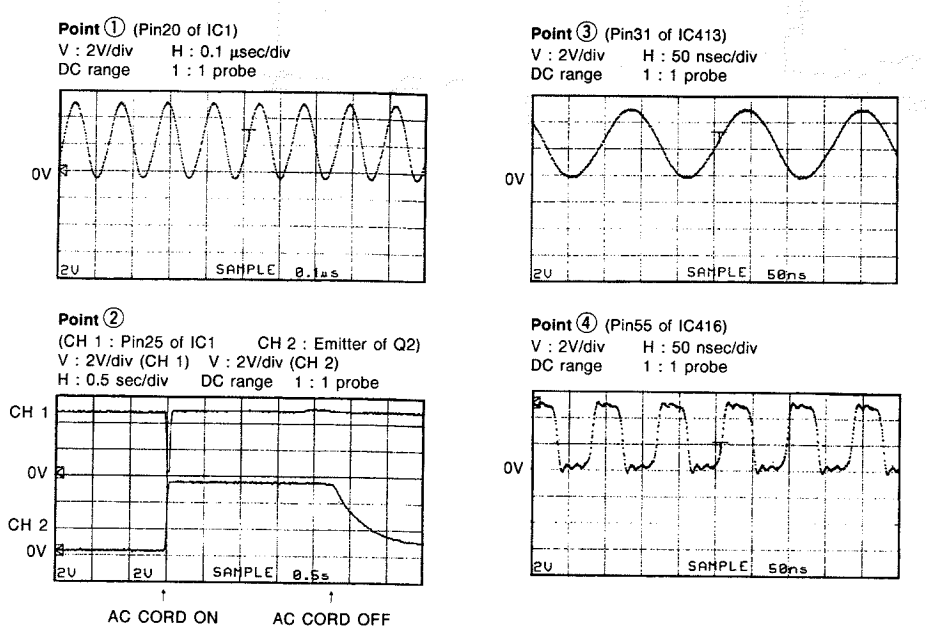
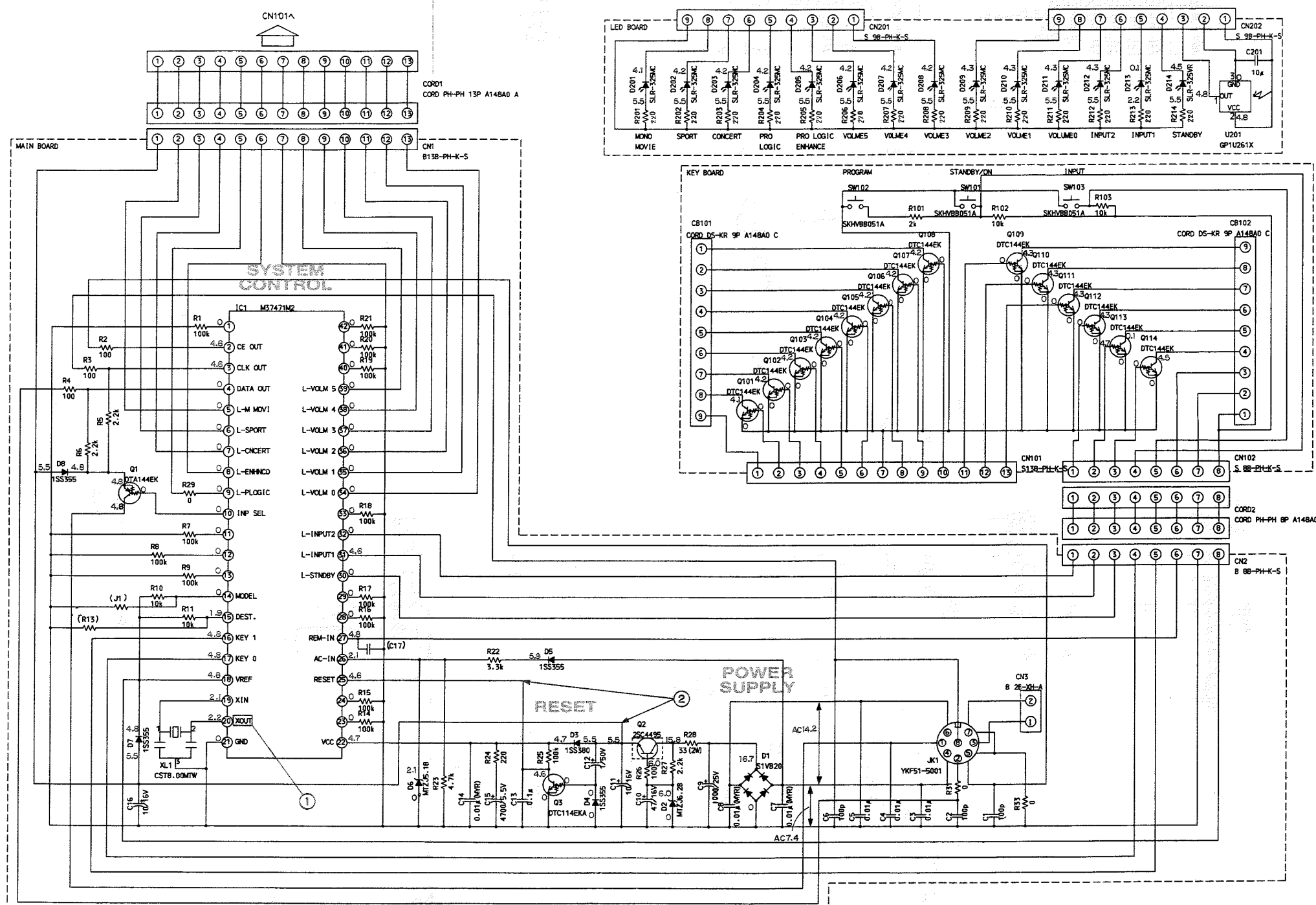

* All voltages are measured with a 10MΩ/V DC electric volt meter.
* Components having special characteristics are marked Δ and must be replaced with parts having specifications equal to those originally installed.
* Schematic diagram is subject to change without notice.

●電圧は、内部抵抗10MΩの電圧計で測定したものです。
●△印のある部品は、安全性確保部分を示しています。部品の交換が必要な場合、パーツリストに記載されている部品を使用してください。
●本回路図は、標準回路図です。改良のため予告なく変更することがございます。

PARTS LIST

■ ELECTRICAL PARTS

■ WARNING

Components having special characteristics are marked \triangle and must be replaced with parts having specifications equal to those originally installed.

● Carbon resistors (1/6W or 1/4W) are not included in the ELECTRICAL PARTS List. For the part Nos. of the carbon resistors refer to the last page.

● Chip resistors are listed on page 36.

ABBREVIATIONS IN THIS LIST ARE AS FOLLOWS :

C.A.EL.CHP	: CHIP ALUMI. ELECTROLYTIC CAP	L.EMIT	: LIGHT EMITTING MODULE
C.CE	: CERAMIC CAP	LED.DSPLY	: LED DISPLAY
C.CE.ARRAY	: CERAMIC CAP ARRAY	LED.INFRD	: LED, INFRARED
C.CE.CHP	: CHIP CERAMIC CAP	MODUL.RF	: MODULATOR, RF
C.CE.ML	: MULTILAYER CERAMIC CAP	PHOT.CPL	: PHOTO COUPLER
C.CE.M.CHP	: CHIP MULTILAYER CERAMIC CAP	PHOT.INTR	: PHOTO INTERRUPTER
C.CE.SAFTY	: RECOGNIZED CERAMIC CAP	PHOT.RFLCT	: PHOTO REFLECTOR
C.CE.TUBLR	: CERAMIC TUBULAR CAP	PIN.TEST	: PIN, TEST POINT
C.CE.SMI	: SEMI CONDUCTIVE CERAMIC CAP	PLST.RIVET	: PLASTIC RIVET
C.EL	: ELECTROLYTIC CAP	R.ARRAY	: RESISTOR ARRAY
C.MICA	: MICA CAP	R.CAR	: CARBON RESISTOR
C.ML.FLM	: MULTILAYER FILM CAP	R.CAR.CHP	: CHIP RESISTOR
C.MP	: METALLIZED PAPER CAP	R.CAR.FP	: FLAME PROOF CARBON RESISTOR
C.MYLAR	: MYLAR FILM CAP	R.FUS	: FUSABLE RESISTOR
C.MYLAR.ML	: MULTILAYER MYLAR FILM CAP	R.MTL.CHP	: CHIP METAL FILM RESISTOR
C.PAPER	: PAPER CAPACITOR	R.MTL.FLM	: METAL FILM RESISTOR
C.PLS	: POLYSTYRENE FILM CAP	R.MTL.OXD	: METAL OXIDE FILM RESISTOR
C.POL	: POLYESTER FILM CAP	R.MTL.PLAT	: METAL PLATE RESISTOR
C.POLY	: POLYETHYLENE FILM CAP	RSNR.CE	: CERAMIC RESONATOR
C.PP	: POLYPROPYLENE FILM CAP	RSNR.CRYS	: CRYSTAL RESONATOR
C.TNTL	: TANTALUM CAP	R.TW.CEM	: TWIN CEMENT FIXED RESISTOR
C.TNTL.CHP	: CHIP TANTALUM CAP	R.WW	: WIRE WOUND RESISTOR
C.TRIM	: TRIMMER CAP	SCR.BND.HD	: BIND HEAD B-TITE SCREW
CN	: CONNECTOR	SCR.BW.HD	: BW HEAD TAPPING SCREW
CN.BS.PIN	: CONNECTOR, BASE PIN	SCR.CUP	: CUP TITE SCREW
CN.CANNON	: CONNECTOR, CANNON	SCR.TERM	: SCREW TERMINAL
CN.DIN	: CONNECTOR, DIN	SCR.TR	: SCREW, TRANSISTOR
CN.FLAT	: CONNECTOR, FLAT CABLE	SUPRT.PCB	: SUPPORT, P.C.B.
CN.POST	: CONNECTOR, BASE POST	SURG.PRTCT	: SURGE PROTECTOR
COIL.MX.AM	: COIL, AM MIX	SW.TACT	: TACT SWITCH
COIL.AT.FM	: COIL, FM ANTENNA	SW.LEAF	: LEAF SWITCH
COIL.DT.FM	: COIL, FM DETECT	SW.LEVER	: LEVER SWITCH
COIL.MX.FM	: COIL, FM MIX	SW.MICRO	: MICRO SWITCH
COIL.OUTPT	: OUTPUT COIL	SW.PUSH	: PUSH SWITCH
DIOD.ARRAY	: DIODE ARRAY	SW.RT.ENC	: ROTARY ENCODER
DIODE.BRG	: DIODE BRIDGE	SW.RT.MTR	: ROTARY SWITCH WITH MOTOR
DIODE.CHP	: CHIP DIODE	SW.RT	: ROTARY SWITCH
DIODE.VAR	: VARACTOR DIODE	SW.SLIDE	: SLIDE SWITCH
DIOD.Z.CHP	: CHIP ZENER DIODE	TERM.SP	: SPEAKER TERMINAL
DIODE.ZENR	: ZENER DIODE	TERM.WRAP	: WRAPPING TERMINAL
DSCR.CE	: CERAMIC DISCRIMINATOR	THRMST.CHP	: CHIP THERMISTOR
FER.BEAD	: FERRITE BEADS	TR.CHP	: CHIP TRANSISTOR
FER.CORE	: FERRITE CORE	TR.DGT	: DIGITAL TRANSISTOR
FET.CHP	: CHIP FET	TR.DGT.CHP	: CHIP DIGITAL TRANSISTOR
FL.DSPLY	: FLUORESCENT DISPLAY	TRANS	: TRANSFORMER
FLTR.CE	: CERAMIC FILTER	TRANS.PULS	: PULSE TRANSFORMER
FLTR.COMB	: COMB FILTER MODULE	TRANS.PWR	: POWER TRANSFORMER ASS'y
FLTR.LC.RF	: LC FILTER, EMI	TUNER.AM	: TUNER PACK, AM
GND.MTL	: GROUND PLATE	TUNER.FM	: TUNER PACK, FM
GND.TERM	: GROUND TERMINAL	TUNER.PK	: FRONT-END TUNER PACK
HOLDER.FUS	: FUSE HOLDER	VR	: ROTARY POTENTIOMETER
IC.PRTCT	: IC PROTECTOR	VR.MTR	: POTENTIOMETER WITH MOTOR
JUMPER.CN	: JUMPER CONNECTOR	VR.SW	: POTENTIOMETER WITH ROTARY SW
JUMPER.TST	: JUMPER, TEST POINT	VR.SLIDE	: SLIDE POTENTIOMETER
L.DTCT	: LIGHT DETECTING MODULE	VR.TRIM	: TRIMMER POTENTIOMETER

Note) Those parts marked with "#" are not included in the P.C.B. ass'y.

SW-AVS7 P.C.B. AMP

AV-S7

Schm Ref.	PART NO.	Description		
	V2147100	P. C. B.	AMP (U)	
	V2147200	P. C. B.	AMP (C)	
	V2147300	P. C. B.	AMP (RT)	
	V2147400	P. C. B.	AMP (A)	
	V2147500	P. C. B.	AMP (BG)	
CB1	VQ963700	CN. BS. PIN	16P	
CB2	VQ963300	CN. BS. PIN	12P	
CB3	VQ963600	CN. BS. PIN	15P	
CB4	VQ963400	CN. BS. PIN	13P	
CB5	VA725700	HOLDER	7P	
CB6	VQ963600	CN. BS. PIN	15P	
CB9	VA725400	HOLDER	4P	
CB10	VA725600	HOLDER	6P	
CB11	VG879900	CN. BS. PIN	2P	
CB14	VP206500	HOLDER. FUS	EYF-52BC	
CB15	VP206500	HOLDER. FUS	EYF-52BC	
CB16	VP206500	HOLDER. FUS	EYF-52BC	
CB17	VP206500	HOLDER. FUS	EYF-52BC	
CB18	VP206500	HOLDER. FUS	EYF-52BC (RT)	
CB19	VP206500	HOLDER. FUS	EYF-52BC (RT)	
CB20	VQ961600	CN	13P	
CB21	VQ963400	CN. BS. PIN	13P	
CB22	VQ962400	CN. BS. PIN	3P	
CB23	VL845400	CN. BS. PIN	10P (ABG)	
C1	UM215100	C. EL	0. 1uF	50V
C2	UM215100	C. EL	0. 1uF	50V
C3	VF466800	C. CE. TUBLR	100pF	50V
C4	VF466800	C. CE. TUBLR	100pF	50V
C5	UM416470	C. EL	4. 7uF	50V
C6	UM416470	C. EL	4. 7uF	50V
C7	VF466700	C. CE. TUBLR	47pF	50V
C8	VF466700	C. CE. TUBLR	47pF	50V
C9	VF466700	C. CE. TUBLR	47pF	50V
C10	VF466700	C. CE. TUBLR	47pF	50V
C11	UM407220	C. EL	22uF	25V
C12	UM407220	C. EL	22uF	25V
C13	VD916400	C. EL	2. 2uF	50V
C14	UA655220	C. MYLAR	0. 22uF	50V
C15	VJ839200	C. EL	2. 2uF	50V
C16	VJ839200	C. EL	2. 2uF	50V
C17	VF466900	C. CE. TUBLR	470pF	50V
C18	VF466900	C. CE. TUBLR	470pF	50V
C19	UA654270	C. MYLAR	0. 027uF	50V
C20	UA654270	C. MYLAR	0. 027uF	50V
C21	UA654270	C. MYLAR	0. 027uF	50V
C22	UA654270	C. MYLAR	0. 027uF	50V
C23	UM407220	C. EL	22uF	25V
C24	UM407220	C. EL	22uF	25V
C25	UJ668100	C. EL	100uF	50V
C26	UJ668100	C. EL	100uF	50V
C27	UM417100	C. EL	10uF	50V
C28	UM417100	C. EL	10uF	50V
C29	UA652560	C. MYLAR	560pF	50V

* New Parts

Schm Ref.	PART NO.	Description		
C30	UA652560	C. MYLAR	560pF	50V
C31	VJ839100	C. EL	1uF	50V
C32	VF760000	C. EL	100uF	10V
C33	UA654470	C. MYLAR	0. 047uF	50V
C34	UA654470	C. MYLAR	0. 047uF	50V
C35	VJ839200	C. EL	2. 2uF	50V
C36	VJ839200	C. EL	2. 2uF	50V
C37	VF466900	C. CE. TUBLR	470pF	50V
C38	VF466900	C. CE. TUBLR	470pF	50V
C39	UA654270	C. MYLAR	0. 027uF	50V
C40	UA654270	C. MYLAR	0. 027uF	50V
C41	UA654270	C. MYLAR	0. 027uF	50V
C42	UA654270	C. MYLAR	0. 027uF	50V
C43	UM407220	C. EL	22uF	25V
C44	UM407220	C. EL	22uF	25V
C45	UJ668100	C. EL	100uF	50V
C46	UJ668100	C. EL	100uF	50V
C47	UM417100	C. EL	10uF	50V
C48	UM417100	C. EL	10uF	50V
C49	UA652560	C. MYLAR	560pF	50V
C50	UA652560	C. MYLAR	560pF	50V
C51	UA654470	C. MYLAR	0. 047uF	50V
C52	UA654470	C. MYLAR	0. 047uF	50V
C53	VJ839100	C. EL	1uF	50V
C54	VF760000	C. EL	100uF	10V
C55	VJ839200	C. EL	2. 2uF	50V
C56	VF466900	C. CE. TUBLR	470pF	50V
C57	UA654270	C. MYLAR	0. 027uF	50V
C58	UA654270	C. MYLAR	0. 027uF	50V
C59	UM407220	C. EL	22uF	25V
C60	UJ668100	C. EL	100uF	50V
C61	UJ668100	C. EL	100uF	50V
C62	UA652560	C. MYLAR	560pF	50V
C63	VJ839100	C. EL	1uF	50V
C64	UA654470	C. MYLAR	0. 047uF	50V
C65	VF760000	C. EL	100uF	10V
C66	VJ836900	C. EL	10uF	16V
C67	VJ836900	C. EL	10uF	16V
C69	UA655220	C. MYLAR	0. 22uF	50V
C70	UA655220	C. MYLAR	0. 22uF	50V
C71	UA655470	C. MYLAR	0. 47uF	50V
C72	VJ836900	C. EL	10uF	16V
C73	VJ836900	C. EL	10uF	16V
C74	UA655390	C. MYLAR	0. 39uF	50V
C75	UA655150	C. MYLAR	0. 15uF	50V
C76	UJ638330	C. EL	330uF	16V
C77	UJ668100	C. EL	100uF	50V
C78	UJ668100	C. EL	100uF	50V
C81	UA653820	C. MYLAR	8200pF	50V
C82	UA654100	C. MYLAR	0. 01uF	50V
C84	VJ836900	C. EL	10uF	16V
C85	VJ836900	C. EL	10uF	16V
C86	VJ837200	C. EL	47uF	16V

* New Parts

SW-AVS7 P.C.B. AMP

Schm Ref.	PART NO.	Description		
C87	VJ836900	C. EL	10uF	16V
C88	VJ836900	C. EL	10uF	16V
C89	UJ638330	C. EL	330uF	16V
C90	UJ638330	C. EL	330uF	16V
C91	Ui367220	C. EL	22uF	50V
C92	Ui367220	C. EL	22uF	50V
C93	VQ670800	C. EL	2200uF	25V
C94	VQ670800	C. EL	2200uF	25V
C95	UA654470	C. MYLAR	0.047uF	50V
C96	UA654470	C. MYLAR	0.047uF	50V
C99	UJ658470	C. EL	470uF	35V
△ * C100	V2087300	C. EL	8200uF	35V
△ * C101	V2087300	C. EL	8200uF	35V
C102	VR325300	C. MYLAR	0.047uF	100V
C103	VR325300	C. MYLAR	0.047uF	100V
C104	FG214100	C. CE	0.01uF	50V
C105	FG214100	C. CE	0.01uF	50V
C106	FG214100	C. CE	0.01uF	50V
C120	UA653330	C. MYLAR	3300pF	50V
C121	UA653330	C. MYLAR	3300pF	50V
C122	UA653330	C. MYLAR	3300pF	50V
C123	UA653330	C. MYLAR	3300pF	50V
C124	UA653560	C. MYLAR	5600pF	50V
C125	UA653560	C. MYLAR	5600pF	50V
C126	VJ839200	C. EL	2.2uF	50V
C127	VJ839200	C. EL	2.2uF	50V
C128	VJ836900	C. EL	10uF	16V
C129	VJ836900	C. EL	10uF	16V
C130	VF466800	C. CE. TUBLR	100pF	50V (ABG)
C131	VF466800	C. CE. TUBLR	100pF	50V (ABG)
C132	VF466800	C. CE. TUBLR	100pF	50V (ABG)
C133	Fi550200	C. CE	2pF	50V
C134	VG276600	C. CE. TUBLR	22pF	50V
C135	VG276600	C. CE. TUBLR	22pF	50V (UCRTA)
C136	VG276600	C. CE. TUBLR	22pF	50V (UCRTA)
C137	VS741700	C. CE. SAFTY	0.01uF	275V (BG)
C357	UA654470	C. MYLAR	0.047uF	50V
C391	VD916400	C. EL	2.2uF	50V
D1	VG438100	DIODE. ZENR	MTZJ6.2C	6.2V
D2	VG438100	DIODE. ZENR	MTZJ6.2C	6.2V
D3	VG440500	DIODE. ZENR	MTZJ13B	13V
D4	VD631600	DIODE	1SS133, 176, HSS104	
△ D5	VQ379300	DIODE. BRG	S1VB20	1.0A 200V
△ D6	VD631600	DIODE	1SS133, 176, HSS104	
D7	Vi234100	DIODE. BRG	RBV-602	
D8	VU264100	DIODE	1SR139-400	
D9	VD631600	DIODE	1SS133, 176, HSS104	
D10	VD631600	DIODE	1SS133, 176, HSS104	
D11	VG437300	DIODE. ZENR	MTZJ5.1A	5.1V
D12	VD631600	DIODE	1SS133, 176, HSS104	
D13	VD631600	DIODE	1SS133, 176, HSS104	
D14	VG438100	DIODE. ZENR	MTZJ6.2C	6.2V
D21	VS132300	LED(re)	SLR-325VCT31	

* New Parts

Schm Ref.	PART NO.	Description		
D22	VD631600	DIODE	1SS133, 176, HSS104	
△ F1	KB000680	FUSE	1.25A	250V (ABG)
△ F1	KB000790	FUSE	T4.0A	250V (RT)
△ F1	VS822900	FUSE	T4.0A	125V (UC)
△ F3	KB001770	FUSE	T1.0A	250V (RTABG)
△ F3	VS822300	FUSE	1.25A	125V (UC)
△ F4	KB000680	FUSE	1.25A	250V (RT)
IC1	XG938A00	IC	BA15218N	
IC2	XK330A00	IC	STK-400-040	25W 3C
IC3	XK330A00	IC	STK-400-040	25W 3C
IC4	XB247301	IC	uPC4570HA	
IC5	XB247301	IC	uPC4570HA	
L1	VB933800	FER. CORE	BP53RB310190N (ABG)	
L100	VZ597900	COIL	48uH	
L306	VC793700	COIL	1.5uH	
Q1	iC287820	TR	2SC2878 A, B	
Q2	iC287820	TR	2SC2878 A, B	
Q3	iC287820	TR	2SC2878 A, B	
Q4	iC287820	TR	2SC2878 A, B	
Q5	iC287820	TR	2SC2878 A, B	
Q6	VD678500	TR. DGT	DTA114ES	
Q7	iC287820	TR	2SC2878 A, B	
Q8	VG721700	TR. DGT	DTA144ES	
Q9	iC224030	TR	2SC2240 GR, BL	
Q10	iC224030	TR	2SC2240 GR, BL	
Q11	iA097000	TR	2SA970 GR, BL	
Q12	iC287820	TR	2SC2878 A, B	
Q13	iC174020	TR	2SC1740S R, S	
Q14	iC224030	TR	2SC2240 GR, BL	
Q15	iC224030	TR	2SC2240 GR, BL	
Q16	iA097000	TR	2SA970 GR, BL	
Q17	iC287820	TR	2SC2878 A, B	
Q18	iC174020	TR	2SC1740S R, S	
Q19	iC224030	TR	2SC2240 GR, BL	
Q20	iA097000	TR	2SA970 GR, BL	
Q21	iC287820	TR	2SC2878 A, B	
Q22	iC174020	TR	2SC1740S R, S	
Q23	iC224030	TR	2SC2240 GR, BL	
Q24	iA097000	TR	2SA970 GR, BL	
Q25	iC224030	TR	2SC2240 GR, BL	
Q26	iA097000	TR	2SA970 GR, BL	
△ Q30	VK407600	TR	2SC4208A Q, R, S	
△ Q31	VK407600	TR	2SC4208A Q, R, S	
Q32	VG722000	TR. DGT	DTC144ES	
△ Q33	VR510800	TR	2SD2396 J, K	
Q34	iA093320	TR	2SA933S Q, R	
△ Q35	VS883300	TR	2SB1565 E, F	
Q36	iC174020	TR	2SC1740S R, S	
R19	HV454220	R. CAR. FP	22 Ω	1/4W
R20	HV454220	R. CAR. FP	22 Ω	1/4W
R33	HV455100	R. CAR. FP	100 Ω	1/4W
R34	HV455100	R. CAR. FP	100 Ω	1/4W
R37	VT424900	R. WW	0.22 Ω	3W

* New Parts

SW-AVS7 P.C.B. AMP & VOLUME

AV-S7

Schm Ref.	PART NO.	Description		
R38	VT424900	R. WW	0.22Ω	3W
R48	HV454100	R. CAR. FP	10Ω	1/4W
R49	HV454100	R. CAR. FP	10Ω	1/4W
R73	HV455100	R. CAR. FP	100Ω	1/4W
R74	HV455100	R. CAR. FP	100Ω	1/4W
R77	VT424900	R. WW	0.22Ω	3W
R78	VT424900	R. WW	0.22Ω	3W
R89	HV454100	R. CAR. FP	10Ω	1/4W
R90	HV454100	R. CAR. FP	10Ω	1/4W
R100	HV455100	R. CAR. FP	100Ω	1/4W
R102	HV455100	R. CAR. FP	100Ω	1/4W
R103	VT424900	R. WW	0.22Ω	3W
R111	HV454100	R. CAR. FP	10Ω	1/4W
R116	HV454220	R. CAR. FP	22Ω	1/4W
R117	HV454220	R. CAR. FP	22Ω	1/4W
R132	HV455100	R. CAR. FP	100Ω	1/4W
R138	HV455100	R. CAR. FP	100Ω	1/4W
R139	HV455100	R. CAR. FP	100Ω	1/4W
R141	HV454100	R. CAR. FP	10Ω	1/4W
R142	VT424900	R. WW	0.22Ω	3W
R148	HV454330	R. CAR. FP	33Ω	1/4W
R154	VK187800	R. FUS	100Ω	1/4W
△ R158	HV453470	R. CAR. FP	4.7Ω	1/4W
△ R159	HV453470	R. CAR. FP	4.7Ω	1/4W
R165	HV454100	R. CAR. FP	10Ω	1/4W
△ R167	HV453100	R. CAR. FP	1Ω	1/4W
△ R188	HV453100	R. CAR. FP	1Ω	1/4W
△ R189	HV453100	R. CAR. FP	1Ω	1/4W
R347	HV454100	R. CAR. FP	10Ω	1/4W
RY1	VV272600	RELAY	DC OSA-SS(URTABG)	
RY1	VZ617300	RELAY	DC DJ24D2-OM(C)	
SW1	VA961800	VOLT. SELCT	ESE-37247-F(RT)	
SW2	VR765000	SW	(BG)	
TE1	VV647100	TERM. SP	CJ-9008	
	VJ828000	PIN	IMSA-6024-03E	
	BB071360	SCR. TERM	8.3x13	
	VS606000	HEAT. SINK	DPS35-45	
	VN126800	HEAT. SINK	UOT-16C25-MP	
	VZ568400	DAMPER	T2x45x100	
	Ei330086	SCR. BND. HD	3x8	FCRM3-BL
*	V2147700	P.C.B.	VOLUME	
CB301	VQ961500	CN. BS. PIN	12P	
CB302	VQ961600	CN	13P	
CB310	VD004600	CN. BS. PIN	3P	
CB403	VQ585700	CN. JUMPER	7P	
CB404	VQ961800	CN. BS. PIN	15P	
CB405	VZ130900	CN. JUMPER	4P	
CB406	VQ585600	CN. JUMPER	6P	
CB407	VQ960600	CN	3P	
C301	VJ836900	C. EL	10uF	16V

* New Parts

Schm Ref.	PART NO.	Description		
C302	VJ836900	C. EL	10uF	16V
C303	VG278400	C. CE. TUBLR	220pF	50V
C304	VG278400	C. CE. TUBLR	220pF	50V
C305	VG278400	C. CE. TUBLR	220pF	50V
C306	VG278400	C. CE. TUBLR	220pF	50V
C307	VF466800	C. CE. TUBLR	100pF	50V
C308	VF466800	C. CE. TUBLR	100pF	50V
C309	VJ836900	C. EL	10uF	16V
C310	VJ836900	C. EL	10uF	16V
C311	UR865220	C. EL	0.22uF	50V
C312	UR865220	C. EL	0.22uF	50V
C313	VJ836900	C. EL	10uF	16V
C314	VJ836900	C. EL	10uF	16V
C315	UR866220	C. EL	2.2uF	50V
C316	UR866220	C. EL	2.2uF	50V
C317	VJ836900	C. EL	10uF	16V
C318	VJ836900	C. EL	10uF	16V
C319	VJ836900	C. EL	10uF	16V
C320	VJ836900	C. EL	10uF	16V
C321	UR865220	C. EL	0.22uF	50V
C322	UR865220	C. EL	0.22uF	50V
C323	VJ836900	C. EL	10uF	16V
C324	VJ836900	C. EL	10uF	16V
C325	VG278400	C. CE. TUBLR	220pF	50V
C326	VG278400	C. CE. TUBLR	220pF	50V
C331	UR865470	C. EL	0.47uF	50V
C332	UR865470	C. EL	0.47uF	50V
C333	VJ836900	C. EL	10uF	16V
C334	VJ836900	C. EL	10uF	16V
C335	VJ836900	C. EL	10uF	16V
C336	VJ836900	C. EL	10uF	16V
C337	VG278400	C. CE. TUBLR	220pF	50V
C340	UR865470	C. EL	0.47uF	50V
C344	UR865220	C. EL	0.22uF	50V
C345	VJ836900	C. EL	10uF	16V
C346	VJ836900	C. EL	10uF	16V
C347	UR865220	C. EL	0.22uF	50V
C348	UR847100	C. EL	10uF	25V
C380	UA653330	C. MYLAR	3300pF	50V
C381	UA653330	C. MYLAR	3300pF	50V
C382	UA653560	C. MYLAR	5600pF	50V
C383	UA653330	C. MYLAR	3300pF	50V
C384	UA653330	C. MYLAR	3300pF	50V
C385	UA653560	C. MYLAR	5600pF	50V
C389	UA655130	C. MYLAR	0.13uF	50V
C390	UA655470	C. MYLAR	0.47uF	50V
C401	VG278400	C. CE. TUBLR	220pF	50V
C402	VG278400	C. CE. TUBLR	220pF	50V
C403	VG278400	C. CE. TUBLR	220pF	50V
C404	VG278400	C. CE. TUBLR	220pF	50V
C405	VJ836900	C. EL	10uF	16V
C406	VJ836900	C. EL	10uF	16V
C408	VJ839100	C. EL	1uF	50V

* New Parts

SW-AVS7 P.C.B. VOLUME & DSP

Schm Ref.	PART NO.	Description		
C409	VJ839100	C. EL	1uF	50V
C411	VF466800	C. CE. TUBLR	100pF	50V
C412	VF466800	C. CE. TUBLR	100pF	50V
C413	VJ836900	C. EL	10uF	16V
C414	VJ836900	C. EL	10uF	16V
C416	VF467300	C. CE. TUBLR	0.01uF	16V
C417	VF466800	C. CE. TUBLR	100pF	50V
C418	FG212100	C. CE	100pF	50V
C419	FG214100	C. CE	0.01uF	50V
C420	FG212100	C. CE	100pF	50V
C421	FG212100	C. CE	100pF	50V
C422	FG214100	C. CE	0.01uF	50V
C424	UA654100	C. MYLAR	0.01uF	50V
C425	UA654100	C. MYLAR	0.01uF	50V
C426	UA654220	C. MYLAR	0.022uF	50V
C427	UA654220	C. MYLAR	0.022uF	50V
C428	FG214100	C. CE	0.01uF	50V
C429	FG214100	C. CE	0.01uF	50V
C430	FG214100	C. CE	0.01uF	50V
C431	FG214100	C. CE	0.01uF	50V
C432	UA654100	C. MYLAR	0.01uF	50V
C433	UA654470	C. MYLAR	0.047uF	50V
D301	VD631600	DIODE	1SS133, 176, HSS104	
D401	VD631600	DIODE	1SS133, 176, HSS104	
D402	VD631600	DIODE	1SS133, 176, HSS104	
D403	VD631600	DIODE	1SS133, 176, HSS104	
IC301	XB247301	IC	uPC4570HA	
IC302	XB247301	IC	uPC4570HA	
IC303	XB247301	IC	uPC4570HA	
IC304	XB247301	IC	uPC4570HA	
IC305	XB247301	IC	uPC4570HA	
IC306	XB247301	IC	uPC4570HA	
IC307	XS884A00	IC	LC7536Y	
IC308	XS884A00	IC	LC7536Y	
IC309	XS884A00	IC	LC7536Y	
* IC401	XU834A00	IC	BU4066BC	
* IC402	XB247301	IC	uPC4570HA	
* PJ401	V2069700	JACK. PIN	6P HSP-246V1-05	
PJ402	VR457700	CN. DIN	8P YKF51-50	
Q401	iC174020	TR	2SC1740S R, S	
Q402	iC174020	TR	2SC1740S R, S	
Q403	iC174020	TR	2SC1740S R, S	
Q404	VG722000	TR. DGT	DTC144ES	
Q405	VD678700	TR. DGT	DTC114ES	
Q406	iE101280	FET	2SK105 F, H	
Q407	iE101280	FET	2SK105 F, H	
Q408	iC287820	TR	2SC2878 A, B	
Q409	iC287820	TR	2SC2878 A, B	
Q410	VD678500	TR. DGT	DTA114ES	
Q411	iE101280	FET	2SK105 F, H	
Q412	iE101280	FET	2SK105 F, H	
R309	HV454220	R. CAR. FP	22Ω	1/4W
R310	HV454220	R. CAR. FP	22Ω	1/4W

* New Parts

Schm Ref.	PART NO.	Description		
R321	HV454220	R. CAR. FP	22Ω	1/4W
R322	HV454220	R. CAR. FP	22Ω	1/4W
R332	HV454220	R. CAR. FP	22Ω	1/4W
R333	HV454220	R. CAR. FP	22Ω	1/4W
R334	HV454220	R. CAR. FP	22Ω	1/4W
R335	HV454220	R. CAR. FP	22Ω	1/4W
R425	HV453220	R. CAR. FP	2.2Ω	1/4W
R426	HV454100	R. CAR. FP	10Ω	1/4W
R427	HV454100	R. CAR. FP	10Ω	1/4W
R428	HV454100	R. CAR. FP	10Ω	1/4W
RY401	VU161600	RELAY	DC OSA-SS-224DM3	
RY402	VU161600	RELAY	DC OSA-SS-224DM3	
RY403	VU161600	RELAY	DC OSA-SS-224DM3	
* TE401	V2152000	TERM. SP	8P	YKD21-0277
	BB071360	SCR. TERM	8.3x13	
* V2269400		P. C. B.	DSP	
CB401	VQ961800	CN. BS. PIN	15P	
CB402	VQ961900	CN	16P	
C401	VJ836900	C. EL	10uF	16V
C402	UB051470	C. CE. M. CHP	47pF	50V
C403	UB051470	C. CE. M. CHP	47pF	50V
C404	UM417100	C. EL	10uF	50V
C405	UA652100	C. MYLAR	100pF	50V
C406	UB051470	C. CE. M. CHP	47pF	50V
C407	UB044100	C. CE. M. CHP	0.01uF	50V
C408	UA652100	C. MYLAR	100pF	50V
C409	UB051330	C. CE. M. CHP	33pF	50V
C410	UA655150	C. MYLAR	0.15uF	50V
C411	VJ839100	C. EL	1uF	50V
C412	VJ839100	C. EL	1uF	50V
C413	UM417100	C. EL	10uF	50V
C414	UM417100	C. EL	10uF	50V
C415	UB051470	C. CE. M. CHP	47pF	50V
C416	UB051470	C. CE. M. CHP	47pF	50V
C417	UM417100	C. EL	10uF	50V
C418	UB052100	C. CE. M. CHP	100pF	50V
C419	UM417100	C. EL	10uF	50V
C420	UB052100	C. CE. M. CHP	100pF	50V
C421	VF964800	C. EL	100uF	16V
C422	Vi536300	C. EL	10uF	50V
C423	UM417100	C. EL	10uF	50V
C424	VF964800	C. EL	100uF	16V
C425	VJ839100	C. EL	1uF	50V
C426	UA652100	C. MYLAR	100pF	50V
C427	UA652100	C. MYLAR	100pF	50V
C428	VJ839100	C. EL	1uF	50V
C429	UM407220	C. EL	22uF	25V
C430	UM407220	C. EL	22uF	25V
C431	UM407220	C. EL	22uF	25V
C432	UB013330	C. CE. M. CHP	3300pF	50V

* New Parts

SW-AVS7 P.C.B. DSP

Schm Ref.	PART NO.	Description		
C433	UB012220	C. CE. M. CHP	220pF	50V
C434	UB013270	C. CE. M. CHP	2700pF	50V
C435	UB012220	C. CE. M. CHP	220pF	50V
C436	UB013270	C. CE. M. CHP	2700pF	50V
C437	UB013330	C. CE. M. CHP	3300pF	50V
C438	UB013680	C. CE. M. CHP	6800pF	50V
C439	UB012270	C. CE. M. CHP	270pF	50V
C440	UB013270	C. CE. M. CHP	2700pF	50V
C441	UB012270	C. CE. M. CHP	270pF	50V
C442	UB013270	C. CE. M. CHP	2700pF	50V
C443	UB013680	C. CE. M. CHP	6800pF	50V
C444	UA652100	C. MYLAR	100pF	50V
C445	UA652100	C. MYLAR	100pF	50V
C446	UM407220	C. EL	22uF	25V
C447	UA652330	C. MYLAR	330pF	50V
C448	UM407220	C. EL	22uF	25V
C449	UA652330	C. MYLAR	330pF	50V
C450	UA652330	C. MYLAR	330pF	50V
C451	UM407220	C. EL	22uF	25V
C452	VJ839100	C. EL	1uF	50V
C453	UB051330	C. CE. M. CHP	33pF	50V
C454	UB051330	C. CE. M. CHP	33pF	50V
C455	VJ839100	C. EL	1uF	50V
C456	UB051330	C. CE. M. CHP	33pF	50V
C457	UB051100	C. CE. M. CHP	10pF	50V
C458	UB051100	C. CE. M. CHP	10pF	50V
C459	UB051330	C. CE. M. CHP	33pF	50V
C460	UA653180	C. MYLAR	1800pF	50V
C461	UA653180	C. MYLAR	1800pF	50V
C462	UM407220	C. EL	22uF	25V
C463	UM407220	C. EL	22uF	25V
C464	UA653470	C. MYLAR	4700pF	50V
C465	UA654100	C. MYLAR	0.01uF	50V
C466	UB012330	C. CE. M. CHP	330pF	50V
C467	UB012330	C. CE. M. CHP	330pF	50V
C468	UA654100	C. MYLAR	0.01uF	50V
C469	UA653470	C. MYLAR	4700pF	50V
C470	UM407220	C. EL	22uF	25V
C471	UM407220	C. EL	22uF	25V
C472	UB013330	C. CE. M. CHP	3300pF	50V
C473	UB013330	C. CE. M. CHP	3300pF	50V
C474	UB045100	C. CE. M. CHP	0.1uF	50V
C475	VJ839200	C. EL	2.2uF	50V
C476	UB045100	C. CE. M. CHP	0.1uF	50V
C477	UB045100	C. CE. M. CHP	0.1uF	50V
C478	UJ638330	C. EL	330uF	16V
C479	VJ837200	C. EL	47uF	16V
C480	VF964800	C. EL	100uF	16V
C481	UA654100	C. MYLAR	0.01uF	50V
C482	UB045100	C. CE. M. CHP	0.1uF	50V
C483	UB045100	C. CE. M. CHP	0.1uF	50V
C484	VE117600	C. EL	220uF	10V
C485	VJ837200	C. EL	47uF	16V

* New Parts

Schm Ref.	PART NO.	Description		
C486	UB045100	C. CE. M. CHP	0.1uF	50V
C501	UA654100	C. MYLAR	0.01uF	50V
C502	VJ839100	C. EL	1uF	50V
C503	VJ839100	C. EL	1uF	50V
C504	VJ839100	C. EL	1uF	50V
C507	UB052100	C. CE. M. CHP	100pF	50V
C508	UB052100	C. CE. M. CHP	100pF	50V
D402	VT332900	DIODE	1SS355	
D403	VT332900	DIODE	1SS355	
D404	VT332900	DIODE	1SS355	
IC401	XR040A00	IC	TC9299P	
IC402	XR040A00	IC	TC9299P	
IC403	XF291A00	IC	uPC4570G2	
IC404	XP896A00	IC	LC78213	
IC405	XJ553A00	IC	NJM2068MD	
IC406	XF291A00	IC	uPC4570G2	
IC407	XF291A00	IC	uPC4570G2	
IC408	XF291A00	IC	uPC4570G2	
IC409	XF291A00	IC	uPC4570G2	
IC410	XF291A00	IC	uPC4570G2	
IC411	iG103520	IC	NJM4558MT-1	
IC412	iG103520	IC	NJM4558MT-1	
IC413	XT622A00	IC	M38172M4-195FP CPU	
IC414	XF291A00	IC	uPC4570G2	
IC415	XF291A00	IC	uPC4570G2	
IC416	Xi022B00	IC	YSS203B-F	
IC417	XQ545A00	IC	LH5P832N-10 PS-RAM	
IC418	XF291A00	IC	uPC4570G2	
IC419	XF291A00	IC	uPC4570G2	
Q401	VB504200	TR. DGT	DTC144EK	
Q402	VB504200	TR. DGT	DTC144EK	
R401	HV453220	R. CAR. FP	2.2Ω	1/4W
R402	HV453220	R. CAR. FP	2.2Ω	1/4W
R495	HV453220	R. CAR. FP	2.2Ω	1/4W
R496	HV453220	R. CAR. FP	2.2Ω	1/4W
R497	HV453220	R. CAR. FP	2.2Ω	1/4W
R541	VN001500	R. ARRAY	100KΩ x8	
XL401	VK175200	RSNR. CE	11.28MHz	
XL402	VR891500	RSNR. CE	6.30MHz	
	BB071360	SCR. TERM	8.3x13	

* New Parts

CHIP RESISTORS

Schm Ref.	PART NO.	Description		
	RD255150	R. CAR. CHP	150Ω	1/10W
	RD255220	R. CAR. CHP	220Ω	1/10W
	RD255470	R. CAR. CHP	470Ω	1/10W
	RD255560	R. CAR. CHP	560Ω	1/10W
	RD256100	R. CAR. CHP	1KΩ	1/10W
	RD256220	R. CAR. CHP	2.2KΩ	1/10W
	RD256270	R. CAR. CHP	2.7KΩ	1/10W
	RD256300	R. CAR. CHP	3KΩ	1/10W
	RD256330	R. CAR. CHP	3.3KΩ	1/10W
	RD256360	R. CAR. CHP	3.6KΩ	1/10W
	RD256470	R. CAR. CHP	4.7KΩ	1/10W
	RD256680	R. CAR. CHP	6.8KΩ	1/10W
	RD257100	R. CAR. CHP	10KΩ	1/10W
	RD257120	R. CAR. CHP	12KΩ	1/10W
	RD257130	R. CAR. CHP	13KΩ	1/10W
	RD257390	R. CAR. CHP	39KΩ	1/10W
	RD257470	R. CAR. CHP	47KΩ	1/10W
	RD258100	R. CAR. CHP	100KΩ	1/10W
	RD258470	R. CAR. CHP	470KΩ	1/10W
	RD259100	R. CAR. CHP	1MΩ	1/10W

* New Parts

NX-AVS7 P.C.B. MAIN

Schm Ref.	PART NO.	Description	Remarks
*	XX698230	P. C. B.	NX-AVS7
*	C1	XX698650 C. CE. CHP	100pF 50V 065858
*	C2	XX698650 C. CE. CHP	100pF 50V 065858
*	C3	XX698680 C. CE. CHP	0.01uF 50V 065610
*	C4	XX698630 C. CE. CHP	0.01uF 50V 065610
*	C5	XX698670 C. CE. CHP	0.01uF 50V 065610
*	C6	XX698650 C. CE. CHP	100pF 50V 065858
*	C7	XX698870 C. POL	0.01uF 50V 065000
*	C8	XX698870 C. POL	0.01uF 50V 065000
*	C9	XX698320 C. EL	1000uF 25V 066709
*	C10	XX698310 C. EL	47uF 16V 066424
*	C11	XX698290 C. EL	10uF 16V 066439
*	C12	XX698300 C. EL	1uF 50V 066377
*	C13	XX698640 C. CE. CHP	0.1uF 16V 065633
*	C14	XX698870 C. POL	0.01uF 50V 065000
*	C15	XX698330 C. EL	4700uF 5.5V 085174
*	C16	XX698290 C. EL	10uF 16V 066439
*	C201	XX698520 C. CE	10uF 16V 043158
*	CB101	XX698350 CN. CORD	DS-KR 9P A148 BK 085226
*	CB102	XX698350 CN. CORD	DS-KR 9P A148 BK 085226
*	CN1	XX698400 CN. BS. PIN	B13B-PH-K-S 081754
*	CN2	LX804480 CN. BS. PIN	B08B-PH-K-S 081725
*	CN3	LX606060 CN. BS. PIN	2P 081436
*	CN101	XX698410 CN. BS. PIN	PH 13P L 081755
*	CN102	XX698380 CN. BS. PIN	S08B-PH-K-S 081756
*	CN201	XX698390 CN. BS. PIN	S13B-PH-K-S 081732
*	CN202	XX698390 CN. BS. PIN	S13B-PH-K-S 081732
*	D1	XX698610 DIODE	SIVB20 085063
*	D2	XX698700 DIODE. ZENR	MTZJ6.2B 6.2V 085286
*	D3	XX698600 DIODE	ISS380 085177
*	D4	XX698570 DIODE	ISS355 069444
*	D5	XX698570 DIODE	ISS355 069444
*	D6	XX698690 DIODE. ZENR	MTZJ5.1B 069087
*	D7	XX698570 DIODE	ISS355 069444
*	D8	XX698590 DIODE	ISS355 069444
*	D201	XX698210 LED(re)	SLR-325MC 085068
*	D202	XX698210 LED(re)	SLR-325MC 085068
*	D203	XX698210 LED(re)	SLR-325MC 085068
*	D204	XX698210 LED(re)	SLR-325MC 085068
*	D205	XX698210 LED(re)	SLR-325MC 085068
*	D206	XX698210 LED(re)	SLR-325MC 085068
*	D207	XX698210 LED(re)	SLR-325MC 085068
*	D208	XX698210 LED(re)	SLR-325MC 085068
*	D209	XX698210 LED(re)	SLR-325MC 085068
*	D210	XX698210 LED(re)	SLR-325MC 085068
*	D211	XX698210 LED(re)	SLR-325MC 085068
*	D212	XX698210 LED(re)	SLR-325MC 085068
*	D213	XX698210 LED(re)	SLR-325MC 085068
*	D214	XX698200 LED(re)	SLR-325VR 085066
*	IC1	XX698180 IC (page 46)	M37471M4-875SP 085073
*	IC1	XU723B00 IC (page 46)	M37471M4-890SP
*	JK1	XX698170 CN	YKF51-5001 085092
*	Q1	XX698710 TR	DTA144EK 069270
*	Q2	XX698750 TR	2SC4495 068893

* New Parts

NX-AVS7 P.C.B. MAIN

Schm Ref.	PART NO.	Description	Remarks
*	Q3	XX698730 TR	DTC114EKA 069349
*	Q101	XX698720 TR	DTC144EK 069311
*	Q102	XX698720 TR	DTC144EK 069311
*	Q103	XX698720 TR	DTC144EK 069311
*	Q104	XX698720 TR	DTC144EK 069311
*	Q105	XX698720 TR	DTC144EK 069311
*	Q106	XX698720 TR	DTC144EK 069311
*	Q107	XX698720 TR	DTC144EK 069311
*	Q108	XX698720 TR	DTC144EK 069311
*	Q109	XX698720 TR	DTC144EK 069311
*	Q110	XX698720 TR	DTC144EK 069311
*	Q111	XX698720 TR	DTC144EK 069311
*	Q112	XX698720 TR	DTC144EK 069311
*	Q113	XX698720 TR	DTC144EK 069311
*	Q114	XX698720 TR	DTC144EK 069311
*	R1	XX699020 R. CAR. CHP	100kΩ 1/8W 067683
*	R2	XX699000 R. CAR. CHP	100Ω 1/8W 067677
*	R3	XX699000 R. CAR. CHP	100Ω 1/8W 067677
*	R4	XX699000 R. CAR. CHP	100Ω 1/8W 067677
*	R5	XX699050 R. CAR. CHP	2.2KΩ 1/8W 067732
*	R6	XX699050 R. CAR. CHP	2.2KΩ 1/8W 067732
*	R7	XX699020 R. CAR. CHP	100kΩ 1/8W 067683
*	R8	XX699020 R. CAR. CHP	100kΩ 1/8W 067683
*	R9	XX699020 R. CAR. CHP	100kΩ 1/8W 067683
*	R10	XX699010 R. CAR. CHP	10KΩ 1/8W 067681
*	R11	XX699010 R. CAR. CHP	10KΩ 1/8W 067681
*	R14	XX699020 R. CAR. CHP	100kΩ 1/8W 067683
*	R15	XX699020 R. CAR. CHP	100kΩ 1/8W 067683
*	R16	XX699020 R. CAR. CHP	100kΩ 1/8W 067683
*	R17	XX699020 R. CAR. CHP	100kΩ 1/8W 067683
*	R18	XX699020 R. CAR. CHP	100kΩ 1/8W 067683
*	R19	XX699020 R. CAR. CHP	100kΩ 1/8W 067683
*	R20	XX699020 R. CAR. CHP	100kΩ 1/8W 067683
*	R21	XX699020 R. CAR. CHP	100kΩ 1/8W 067683
*	R22	XX699060 R. CAR. CHP	3.3KΩ 1/8W 067758
*	R23	XX699070 R. CAR. CHP	4.7KΩ 1/8W 067779
*	R24	XX699040 R. CAR. CHP	220Ω 1/8W 067730
*	R25	XX699020 R. CAR. CHP	100kΩ 1/8W 067683
*	R26	XX699000 R. CAR. CHP	100Ω 1/8W 067677
*	R27	XX699050 R. CAR. CHP	2.2KΩ 1/8W 067732
*	R28	XX699080 R. METAL	33Ω 2W 068019
*	R29	XX698990 R. CAR. CHP	0Ω 1/8W 067674
*	R31	XX698990 R. CAR. CHP	0Ω 1/8W 067674
*	R33	XX698990 R. CAR. CHP	0Ω 1/8W 067674
*	R101	XX699030 R. CAR. CHP	2KΩ 1/8W 067724
*	R102	XX699010 R. CAR. CHP	10KΩ 1/8W 067681
*	R103	XX699010 R. CAR. CHP	10KΩ 1/8W 067681
*	R201	XX699040 R. CAR. CHP	220Ω 1/8W 067730
*	R202	XX699040 R. CAR. CHP	220Ω 1/8W 067730
*	R203	XX699040 R. CAR. CHP	220Ω 1/8W 067730
*	R204	XX699040 R. CAR. CHP	220Ω 1/8W 067730
*	R205	XX699040 R. CAR. CHP	220Ω 1/8W 067730
*	R206	XX699040 R. CAR. CHP	220Ω 1/8W 067730

* New Parts

Schm Ref.	PART NO.	Description	Remarks
*	R207	XX699040 R. CAR. CHP	220Ω 1/8W 067730
*	R208	XX699040 R. CAR. CHP	220Ω 1/8W 067730
*	R209	XX699040 R. CAR. CHP	220Ω 1/8W 067730
*	R210	XX699040 R. CAR. CHP	220Ω 1/8W 067730
*	R211	XX699040 R. CAR. CHP	220Ω 1/8W 067730
*	R212	XX699040 R. CAR. CHP	220Ω 1/8W 067730
*	R213	XX699040 R. CAR. CHP	220Ω 1/8W 067730
*	R214	XX699040 R. CAR. CHP	220Ω 1/8W 067730
*	SW101	XX698560 SW. TACT	SKHVBB051A 072682
*	SW103	XX698560 SW. TACT	SKHVBB051A 072682
*	SW102	XX698560 SW. TACT	SKHVBB051A 072682
*	U201	XX698920 L. DTCT	GP1U261X 085069
*	XL1	XX698530 RSNR. CE	CST8 00MTW 085096
*		XX698880 LUG	MET37-0001 075878
*		XX698360 CN. CORD	PH-PH 13P A148 BK 085224
*		XX698340 CN. CORD	PH-PH 8P A148BK 085225
*		XX698190 SOCKET. IC	CLC3042-0101 085093
*		XX698800 SCR	PN S-B M3X8 ZC 075152
*		EP600190 SCR. BND. HD	3x8 BL 075638
*		XX698980 HEAT. SINK	TR A148A0 085029

* New Parts

AV-S7

SW-AVS7 EXPLODED VIEW

1

2

3

4

5

6

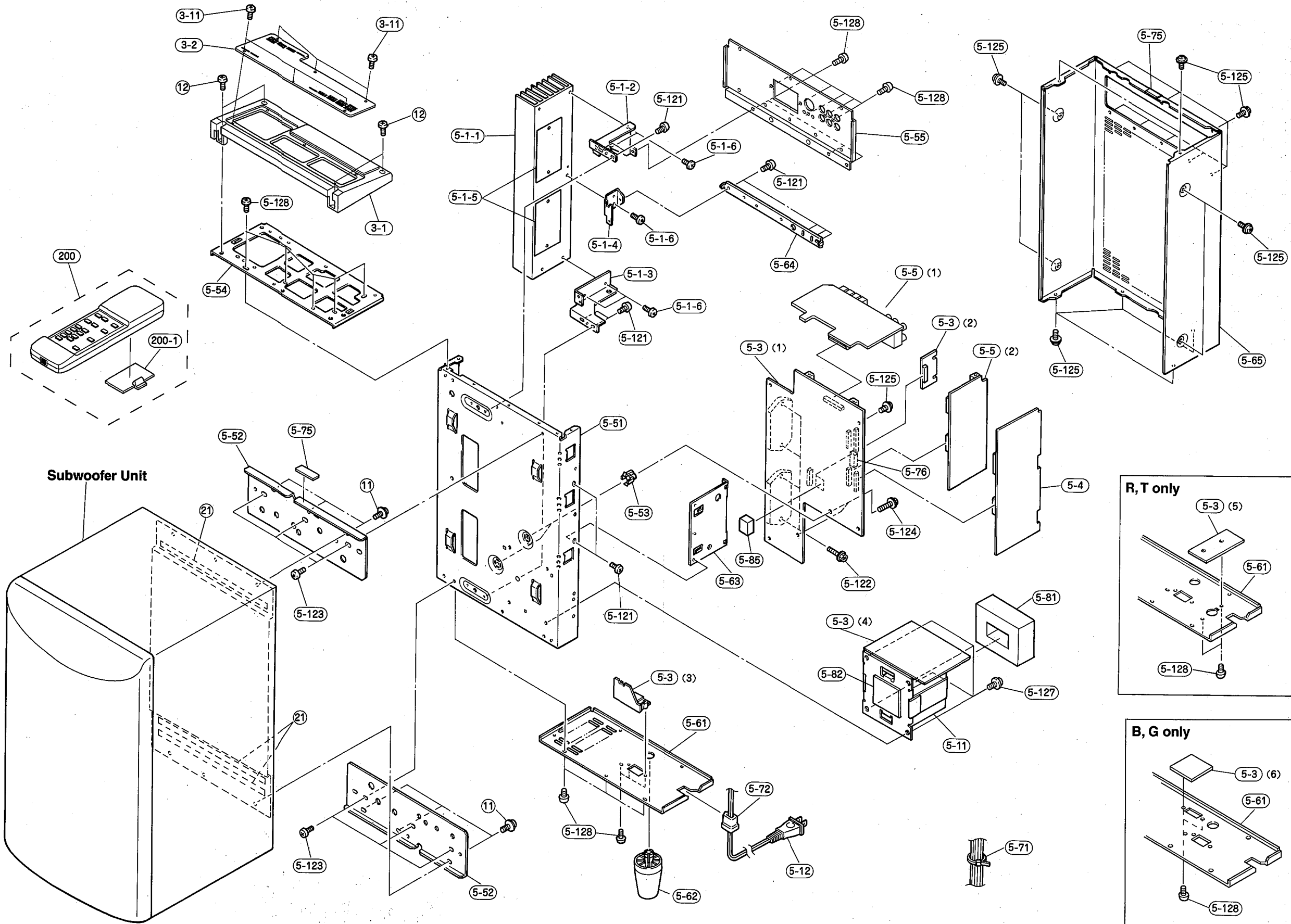

Subwoofer Unit

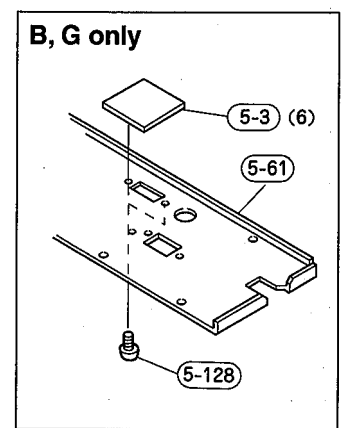
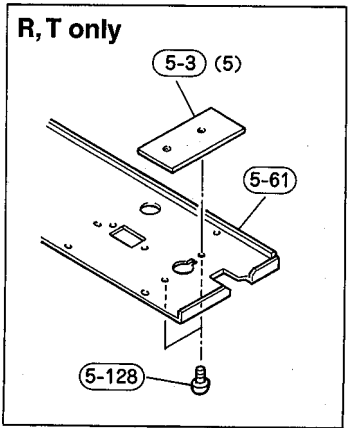

■ SW-AVS7 MECHANICAL PARTS

Ref. No.	PART NO.	Description	Remarks	Markets
3- 1	VV982100	GRILLE		
3- 2	VY738500	PLATE, GRILL		
3-11	EX601590	BIND HEAD P-TITE SCREW	2.6x8 FCRM3-BL	
5-1-1	VV967500	HEAT SINK		
5-1-2	VV967100	HOLDER, HS-L		
5-1-3	VV967200	HOLDER, HS-R		
5-1-4	VV967400	HOLDER, HS-MID		
5-1-5	VV877700	RADIATION SHEET	48x80 TBM-51W	
5-1-6	Ei330086	BIND HEAD B-TITE SCREW	3x8 FCRM3-BL	
* 5-3	V2147100	P. C. B. ASS'Y	AMP	(U)
* 5-3	V2147200	P. C. B. ASS'Y	AMP	(C)
* 5-3	V2147300	P. C. B. ASS'Y	AMP	(RT)
* 5-3	V2147400	P. C. B. ASS'Y	AMP	(A)
* 5-3	V2147500	P. C. B. ASS'Y	AMP	(BG)
* 5-4	V2269400	P. C. B. ASS'Y	DSP	
* 5-5	V2147700	P. C. B. ASS'Y	VOLUME	
△ 5-11	XS923A00	POWER TRANSFORMER		(UC)
△ 5-11	XS924A00	POWER TRANSFORMER		(RT)
△ 5-11	XS925A00	POWER TRANSFORMER		(A)
△ 5-11	XS926A00	POWER TRANSFORMER		(BG)
△ 5-12	V2296800	POWER CORD ASS'Y		(A)
△ 5-12	VL238100	POWER CORD ASS'Y		(R)
△ 5-12	VN363700	POWER CORD ASS'Y		(G)
△ 5-12	VV437200	POWER CORD ASS'Y		(UC)
△ 5-12	VV437300	POWER CORD ASS'Y		(B)
△ 5-12	VZ542500	POWER CORD ASS'Y		(T)
5-51	VV966300	CHASSIS		
5-52	VV966800	PLATE, CHASSIS		
5-53	VR264400	SPACER	H8	
5-54	VV966500	PANEL, TOP		
* 5-55	V2010900	PANEL, REAR		
* 5-61	V2011100	PANEL, BOTTOM		(U)
* 5-61	V2011200	PANEL, BOTTOM		(C)
* 5-61	V2011300	PANEL, BOTTOM		(RT)
* 5-61	V2011400	PANEL, BOTTOM		(A)
* 5-61	V2011500	PANEL, BOTTOM		(BG)
5-62	VV981900	LEG	HA02055-80	
5-63	VV967000	HOLDER, PANEL		
5-64	VV967300	FRAME		
5-65	VV966200	TOP COVER		
5-71	VU590000	BINDING TIE	CBID001B	
5-72	VN158600	CORD STOPPER	No. 2104	
5-75	VZ221400	DAMPER	1x5x20	
5-76	VZ544200	SPACER	T13x10x20	
5-81	VZ699800	DAMPER	31x60x80	
5-82	VZ709700	DAMPER	1x50x50	
* 5-85	V2126100	SPACER	T14x15x15	
5-121	Ei330086	BIND HEAD B-TITE SCREW	3x8 FCRM3-BL	
5-122	VK865300	HEX. HEAD TAP. SCREW WITH WS	3x18 FCRM3-BL	
5-123	Ei340086	BIND HEAD TAPPING SCREW	4x8 FCRM3-BL	
5-124	VT669400	PW HEAD B-TITE SCREW	3x15-8 MFC2	
5-125	VE529700	PW HEAD B-TITE SCREW	3x6-8 FCRM3-BL	
5-127	VU081700	PAN W.HEAD TAPPING SCREW	4x6-10 MFZN2-BL	

* New Parts

Ref. No.	PART NO.	Description	Remarks	Markets
5-128	VN413300	BIND HEAD BONDING B-T. SCREW	3x8 MFZN2-BL	
11	VU081700	PAN W.HEAD TAPPING SCREW	4x6-10 MFZN2-BL	
12	Ei330086	BIND HEAD B-TITE SCREW	3x8 FCRM3-BL	
21	V2175800	DAMPER	T2x10x220	
		ACCESSORIES		
* 200	V0045500	REMOTE CONTROL TRANSMITTER	SBAR20347A SYS8	
* 200-1	CX675150	LID	54x32.9BLALPS	
	V2152200	DIN PLUG	3m	
	V2168300	RCA PIN CORD	3m	
		BATTERY, MANGANESE	SUM-3, AA, R06	

* New Parts

AV-S7

1 ■ NX-AVS7 EXPLODED VIEW

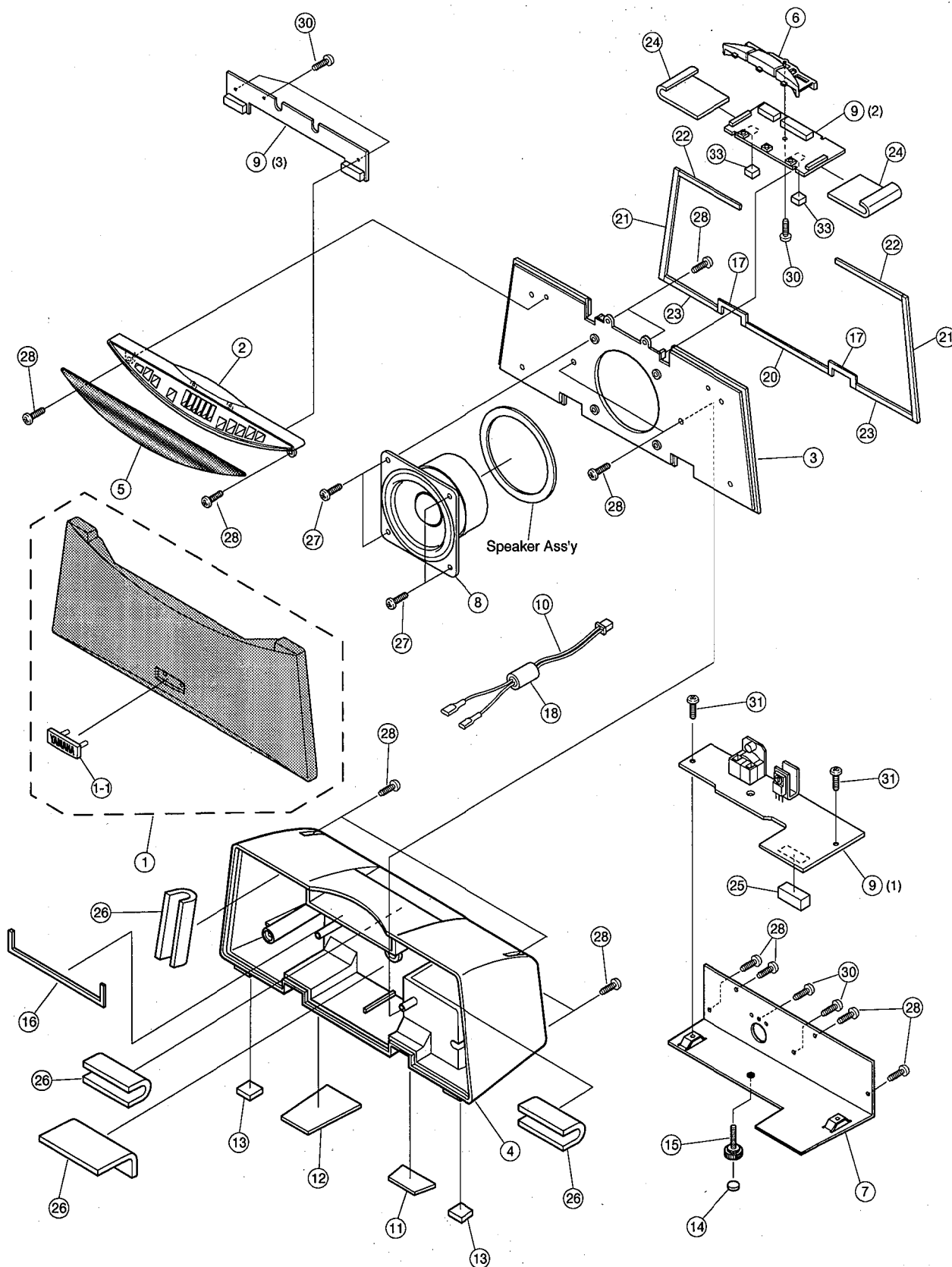

■ NX-AVS7 MECHANICAL PARTS

Ref. No.	PART NO.	Description	Remarks	Markets
*	XX698540	CENTER SPEAKER		U080L03N1595
* 1	XX698280	GRILLE ASS'Y		B613700
* 1-1	VT136600	EMBLEM		051551500
* 2	XX698840	PANEL, FRAME		0511121100
* 3	XX698820	BAFFLE		05371600
* 4	XX698890	REAR CASE		056048300
* 5	XX698830	PANEL, WINDOW		0511121400
* 6	XX698860	BUTTON		0511120201
* 7	XX698910	REAR PANEL		0511120301
* 8	XU767A00	SPEAKER		C080P07N1598
* 9	XX698230	P.C.B. ASS'Y		A148A08F0000
* 10	XX698370	CORD, SP		054319800
* 11	XX698960	CONCEALED CAP	A	0511121200
* 12	XX698970	CONCEALED CAP	B	0511121300
* 13	XX698930	FOOT		0561156300
* 14	XX698940	FOOT	SHAFT	0561156400
* 15	XX698510	SHAFT	M4	054024000
* 16	XX698420	SEAL	BAFFLE	0561156500
* 17	XX698430	SEAL	BAFFLE	0561156600
* 18	XX698440	SEAL	SP CORD	0561156700
* 20	XX698460	SEAL	BAFFLE	0561156900
* 21	XX698470	SEAL	BAFFLE	0561156901
* 22	XX698480	SEAL	BAFFLE	0561156902
* 23	XX698490	SEAL	BAFFLE	0561156903
* 24	XX698500	SEAL	SW PCB	0561611100
* 25	XX698270	CUSHION	MAIN PCB	0561157700
* 26	XX698620	SOUND ABSORBER		0564600800
* 27	XX698790	SCREW	4x10 SPEAKER	05409900
* 28	XX698780	SCREW	3x12	05409611
* 30	XX698760	SCREW	3x8 PCB ASS'Y	054024100
* 31	XX698770	SCREW	3x6 PCB	054024101
* 33	XX698450	CUSHION	PCB	0561610200
	NX635860	EFFECT SPEAKER	NX-AV1	S080H09N1598
	AX624360	ACCESSORIES		
	AX624330	WALL BRACKET		051626401
	XX698950	BRACKET		051625900
	XX698250	FASTENER TAPE		0511121800
	XX698240	SPEAKER CABLE	15mx2	055048100
	XX698810	SPEAKER CABLE	6m x2	055047900
	NX635930	SCREW ASS'Y		B5940405
		STAND ASS'Y	CENTER, FOOT x4	B5916009

* New Parts

1
2
3
4
5
6
7

1

■ SW-AVS7 EXPLODED VIEW (Sub Woofer Unit)

2

3

4

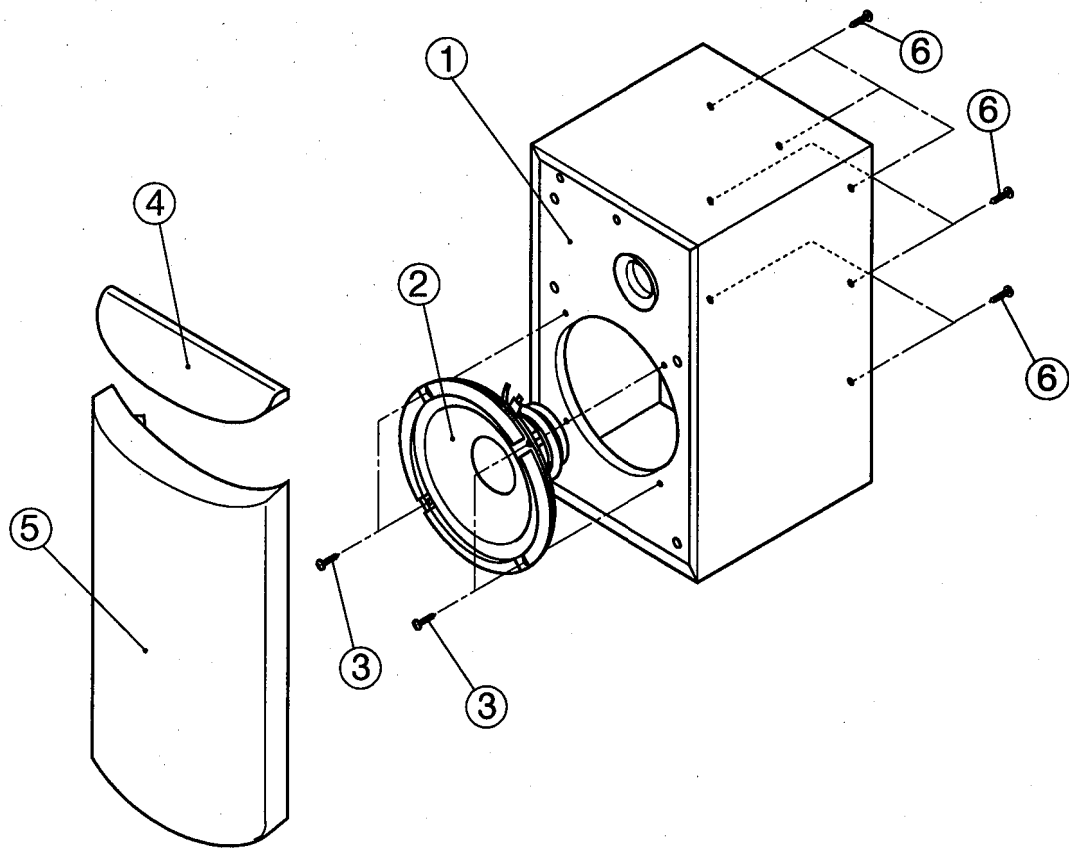

5

6

7

Ref. No.	PART NO.	Description	Remarks	Markets	
1	NX635880	ENCLOSURE	SW-AV1	053820700	UCRAT
1	NX635890	ENCLOSURE	SW-AV1	053820701	BG
2	JX601740	SPEAKER		C200R10N1513	
3	EX604140	SCREW	4x20	994043042017	
4	DX603680	TOP PANEL		0511114500	
5	NX635900	GRILLE ASS'Y		B6134200	
6	EQ141256	ROUND HEAD WOOD SCREW	4.1x25 ZMC2-BL		

*New Parts

A B C D E

AV-S7

REMOTE CONTROL TRANSMITTER

■ SCHEMATIC DIAGRAM

Key No.	FUNCTION	CUSTOM (HEX)	DATA (HEX)	CUSTOM (BIN)	DATA (BIN)
1	ENHANCED A	78	91	0001 1110	1000 1001
2		78	96	0001 1110	0110 1001
3		78	97	0001 1110	1110 1001
4	OFF	78	90	0001 1110	0000 1001
5	CONCERT C	78	93	0001 1110	1100 1001
6	PRO LOGIC B	78	92	0001 1110	0100 1001
7		78	99	0001 1110	1001 1001
8		78	98	0001 1110	0001 1001
9	MONO MOVIE E	78	95	0001 1110	1010 1001
10	SPORTS D	78	94	0001 1110	0010 1001
11		78	9B	0001 1110	1101 1001
12		78	9A	0001 1110	0101 1001
13	CENTER +	78	86	0001 1110	0110 0001
14	CENTER -	78	87	0001 1110	1110 0001
15		78	9C	0001 1110	0011 1001
16	TEST	78	5F	0001 1110	1111 1010
17	REAR +	78	88	0001 1110	0001 0001
18	REAR -	78	89	0001 1110	1001 0001
19		78	9E	0001 1110	0111 1001
20		78	9D	0001 1110	1011 1001
21		78	8A	0001 1110	0101 0001
22		78	8B	0001 1110	1101 0001
23		78	8C	0001 1110	0011 0001
24		78	9F	0001 1110	1111 1001
25	SUBWOOFER +	78	4C	0001 1110	0011 0010
26	SUBWOOFER -	78	4D	0001 1110	1011 0010
27		78	8D	0001 1110	1011 0001
28	INPUT 1/2	78	5E	0001 1110	0111 0010
29		78	C1	0001 1110	1000 0011
30		78	C0	0001 1110	0000 0011
31		78	8F	0001 1110	1111 0001
32		78	8E	0001 1110	0111 0001
33	VOLUME +	78	1E	0001 1110	0111 1000
34	VOLUME -	78	1F	0001 1110	1111 1000
35		78	C2	0001 1110	0100 0011
36	POWER ○/I	78	0F	0001 1110	1111 0000

45

■ MICROPROCESSOR & VOLUME FUNCTION (VOLUME LED lighting pattern changed)

• The specifications for the microprocessor (IC1) of NX-AVS7 are modified as follows.

Before modification

After modification

IC1 : M37471M4-875SP (XU723A0)
(P/No. XX698180)



IC1 : M37471M4-890SP (XU723B0)
(P/No. XU723B00)

• Main volume (UP/DOWN)

Before modification

VOLUME LED	dB	VOLUME LED	dB	VOLUME LED	dB
[]	0	[.]	-22	[.....]	-44
[]	-1	[.]	-23	[.....]	-45
[]	-2	[.]	-24	[.....]	-46
[]	-3	[.]	-25	[.....]	-47
[]	-4	[.]	-26	[.....]	-48
[]	-5	[.]	-27	[.....]	-49
[]	-6	[.]	-28	[.....]	-50
[]	-7	[.]	-29	[.....]	-51
[]	-8	[.]	-30	[.....]	-52
[]	-9	[.]	-31	[.....]	-53
[.]	-10	[.]	-32	[.....]	-54
[.]	-11	[.]	-33	[.....]	-55
[.]	-12	[.]	-34	[.....]	-56
[.]	-13	[.]	-35	[.....]	-57
[.]	-14	[.]	-36	[.....]	-58
[.]	-15	[.]	-37	[.....]	-59
[.]	-16	[.]	-38	[.....]	-61
[.]	-17	[.]	-39	[.....]	-64
[.]	-18	[.]	-40	[.....]	-68
[.]	-19	[.]	-41	[.....]	-73
[.]	-20	[.]	-42	[.....]	-79
[.]	-21	[.]	-43	[.....]	∞

* When the VOLUME is at MIN (∞), the AMP MUTE function turns on.

After modification

VOLUME LED	dB	VOLUME LED	dB	VOLUME LED	dB
[]	0	[.]	-22	[.....]	-44
[]	-1	[.]	-23	[.....]	-45
[]	-2	[.]	-24	[.....]	-46
[]	-3	[.]	-25	[.....]	-47
[]	-4	[.]	-26	[.....]	-48
[]	-5	[.]	-27	[.....]	-49
[]	-6	[.]	-28	[.....]	-50
[]	-7	[.]	-29	[.....]	-51
[]	-8	[.]	-30	[.....]	-52
[]	-9	[.]	-31	[.....]	-53
[]	-10	[.]	-32	[.....]	-54
[]	-11	[.]	-33	[.....]	-55
[.]	-12	[.]	-34	[.....]	-56
[.]	-13	[.]	-35	[.....]	-57
[.]	-14	[.]	-36	[.....]	-58
[.]	-15	[.]	-37	[.....]	-59
[.]	-16	[.]	-38	[.....]	-61
[.]	-17	[.]	-39	[.....]	-64
[.]	-18	[.]	-40	[.....]	-68
[.]	-19	[.]	-41	[.....]	-73
[.]	-20	[.]	-42	[.....]	-79
[.]	-21	[.]	-43	[.....]	∞

* When the VOLUME is at MIN (∞), the AMP MUTE function turns on.

Parts List for Carbon Resistors

AV-S7

Value	1/4W Type Part No.	1/6W Type Part No.	Value	1/4W Type Part No.	1/6W Type Part No.
1.0 Ω	HJ35 3100	HF85 3100	10 kΩ	HF45 7100	HF45 7100
1.8 Ω	HJ35 3180	*	11 kΩ	HF45 7110	HF45 7110
2.2 Ω	HJ35 3220	HF85 3220	12 kΩ	HJ35 7120	HF85 7120
3.3 Ω	HJ35 3330	HF85 3330	13 kΩ	HF45 7130	HF45 7130
4.7 Ω	HJ35 3470	HF85 3470	15 kΩ	HF45 7150	HF45 7150
5.6 Ω	HJ35 3560	HF85 3560	18 kΩ	HF45 7180	HF45 7180
10 Ω	HF45 4100	HF45 4100	22 kΩ	HF45 7220	HF45 7220
15 Ω	HJ35 4150	HF85 4150	24 kΩ	HF45 7240	HF45 7240
22 Ω	HF45 4220	HF45 4220	27 kΩ	HJ35 7270	HF85 7270
27 Ω	HJ35 4270	HF85 4270	30 kΩ	HF45 7300	HF45 7300
33 Ω	HF45 4330	HF45 4330	33 kΩ	HF45 7330	HF45 7330
39 Ω	HJ35 4470	HF85 4390	36 kΩ	HF45 7360	HF45 7360
47 Ω	HF45 4470	HF45 4470	39 kΩ	HF45 7390	HF45 7390
56 Ω	HF45 4560	HF45 4560	47 kΩ	HF45 7470	HF45 7470
68 Ω	HF45 4680	HF45 4680	51 kΩ	HF45 7510	HF45 7510
75 Ω	HF45 4750	HF45 4750	56 kΩ	HF45 7560	HF45 7560
82 Ω	HF45 4820	HF45 4820	62 kΩ	HF45 7620	HF45 7620
91 Ω	HF45 4910	HF45 4910	68 kΩ	HF45 7680	HF45 7680
100 Ω	HF45 5100	HF45 5100	82 kΩ	HF45 7820	HF45 7820
110 Ω	HJ35 5110	HF85 5110	91 kΩ	HF45 7910	HF45 7910
120 Ω	HF45 5120	HF45 5120	100 kΩ	HF45 8100	HF45 8100
150 Ω	HF45 5150	HF45 5150	110 kΩ	HF45 8110	HF45 8110
160 Ω	HJ35 5160	*	120 kΩ	HF45 8120	HF45 8120
180 Ω	HF45 5180	HF45 5180	150 kΩ	HF45 8150	HF45 8150
200 Ω	HF45 5200	HF45 5200	180 kΩ	HF45 8180	HF45 8180
220 Ω	HF45 5220	HF45 5220	220 kΩ	HJ35 8220	HF85 8220
270 Ω	HF45 5270	HF45 5270	270 kΩ	HF45 8270	HF45 8270
330 Ω	HF45 5330	HF45 5330	300 kΩ	HF45 8300	HF45 8300
390 Ω	HF45 5390	HF45 5390	330 kΩ	HF45 8330	HF45 8330
430 Ω	HF45 5430	HF45 5430	390 kΩ	HJ35 8390	HF85 8390
470 Ω	HF45 5470	HF45 5470	470 kΩ	HF45 8470	HF45 8470
510 Ω	HF45 5510	HF45 5510	560 kΩ	HJ35 8560	HF85 8560
560 Ω	HF45 5560	HF45 5560	680 kΩ	HJ35 8680	HF85 8680
680 Ω	HF45 5680	HF45 5680	820 kΩ	HJ35 8820	HF85 8820
820 Ω	HF45 5820	HF45 5820	1.0 MΩ	HF45 9100	HF45 9100
910 Ω	HF45 5910	HF45 5910	1.2 MΩ	HJ35 9120	*
1.0 kΩ	HF45 6100	HF45 6100	1.5 MΩ	HJ35 9150	HF85 9150
1.2 kΩ	HF45 6120	HF45 6120	1.8 MΩ	HJ35 9180	HF85 9180
1.5 kΩ	HF45 6150	HF45 6150	2.2 MΩ	HJ35 9220	HF85 9220
1.8 kΩ	HF45 6180	HF45 6180	3.3 MΩ	HJ35 9330	HF85 9330
2.0 kΩ	HJ35 6200	HF85 6200	3.9 MΩ	HJ35 9390	*
2.2 kΩ	HF45 6220	HF45 6220	4.7 MΩ	HJ35 9470	HF85 9470
2.4 kΩ	HJ35 6240	HF85 6240			
2.7 kΩ	HF45 6270	HF45 6270			
3.0 kΩ	HF45 6300	HF45 6300			
3.3 kΩ	HF45 6330	HF45 6330			
3.6 kΩ	HJ35 6360	HF85 6360			
3.9 kΩ	HF45 6390	HF45 6390			
4.7 kΩ	HF45 6470	HF45 6470			
5.1 kΩ	HF45 6510	HF45 6510			
5.6 kΩ	HF45 6560	HF45 6560			
6.8 kΩ	HF45 6680	HF45 6680			
8.2 kΩ	HF45 6820	HF45 6820			
9.1 kΩ	HF45 6910	HF45 6910			

