

HOME THEATER SYSTEM

AV-S70/NX-SW70

SERVICE MANUAL

NX-SW70 is composed of SW-AVS70 and NX-AVS70s.

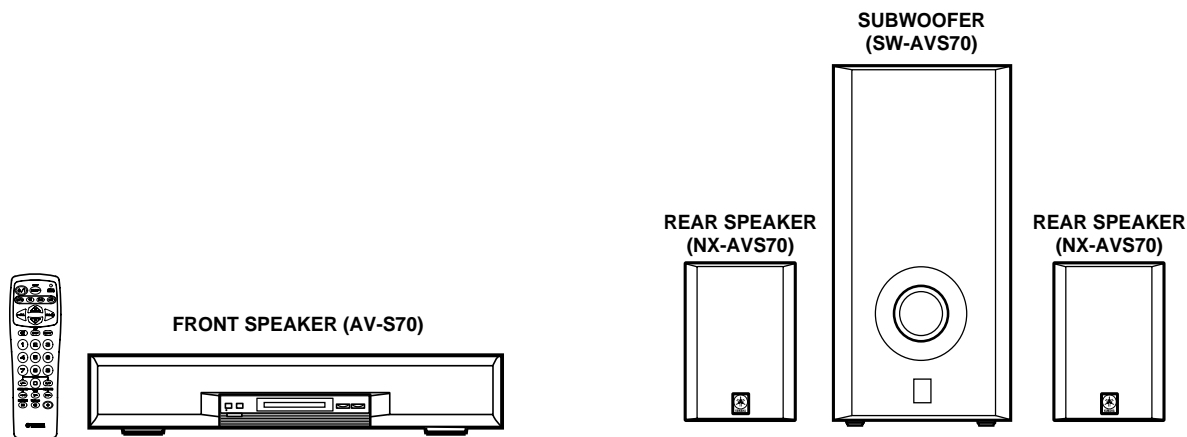

IMPORTANT NOTICE

This manual has been provided for the use of authorized YAMAHA Retailers and their service personnel. It has been assumed that basic service procedures inherent to the industry, and more specifically YAMAHA Products, are already known and understood by the users, and have therefore not been restated.

WARNING: Failure to follow appropriate service and safety procedures when servicing this product may result in personal injury, destruction of expensive components, and failure of the product to perform as specified. For these reasons, we advise all YAMAHA product owners that any service required should be performed by an authorized YAMAHA Retailer or the appointed service representative.

IMPORTANT: The presentation or sale of this manual to any individual or firm does not constitute authorization, certification or recognition of any applicable technical capabilities, or establish a principle-agent relationship of any form.

The data provided is believed to be accurate and applicable to the unit(s) indicated on the cover. The research, engineering, and service departments of YAMAHA are continually striving to improve YAMAHA products. Modifications are, therefore, inevitable and specifications are subject to change without notice or obligation to retrofit. Should any discrepancy appear to exist, please contact the distributor's Service Division.

WARNING: Static discharges can destroy expensive components. Discharge any static electricity your body may have accumulated by grounding yourself to the ground buss in the unit (heavy gauge black wires connect to this buss).

IMPORTANT: Turn the unit OFF during disassembly and part replacement. Recheck all work before you apply power to the unit.

CONTENTS

TO SERVICE PERSONNEL	1
FRONT/REAR PANELS	1—2
SPECIFICATIONS	3
DISASSEMBLY PROCEDURES	4
TEST PROGRAM MODE	5—6
DSP DIAG MODE	7—13
AV-S70 IC DATA	14—20
AV-S70 BLOCK DIAGRAM	21—22

SW-AVS70 BLOCK DIAGRAM	23
AV-S70 PRINTED CIRCUIT BOARD	24—33
SW-AVS70 PRINTED CIRCUIT BOARD	34—35
AV-S70 SCHEMATIC DIAGRAM	36—39
SW-AVS70 SCHEMATIC DIAGRAM	40
PARTS LIST	41—54
REMOTE CONTROL TRANSMITTER	55



このサービスマニュアルは、エコマーク認定の再生紙を使用しています。
This Service Manual uses recycled paper.



■ TO SERVICE PERSONNEL

Critical Components Information.

Components having special characteristics are marked ⚠ and must be replaced with parts having specifications equal to those originally installed.

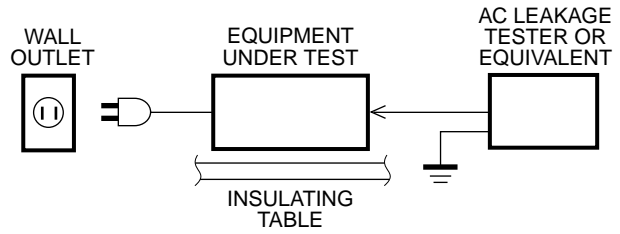

■ FRONT/REAR PANELS

▼ AV-S70

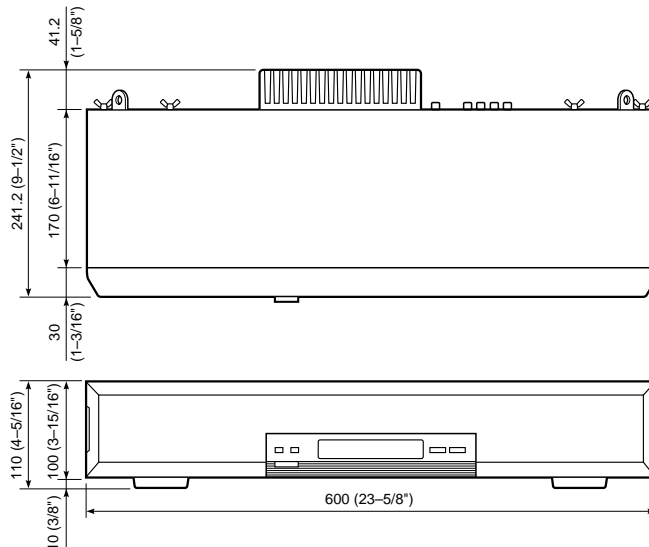
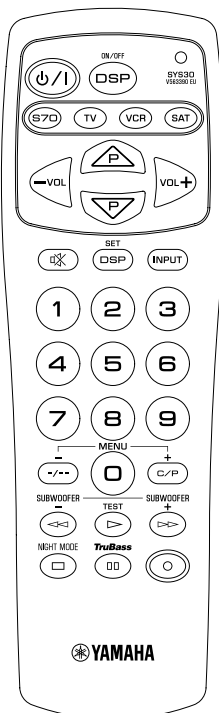
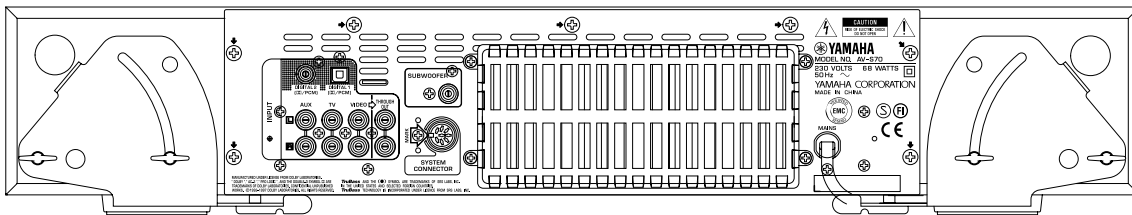
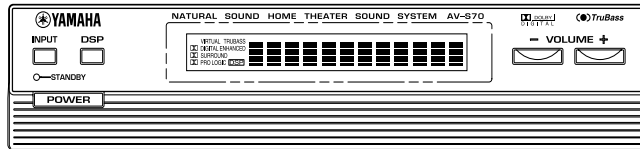

AV-S70/NX-SW70

▼ SW-AVS70

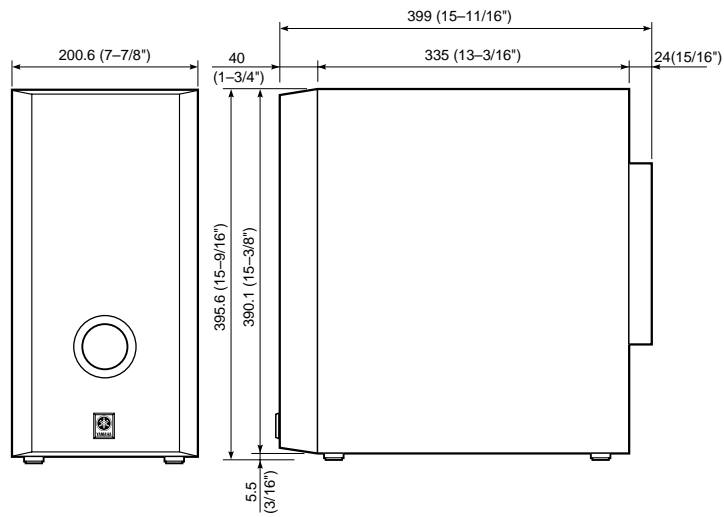
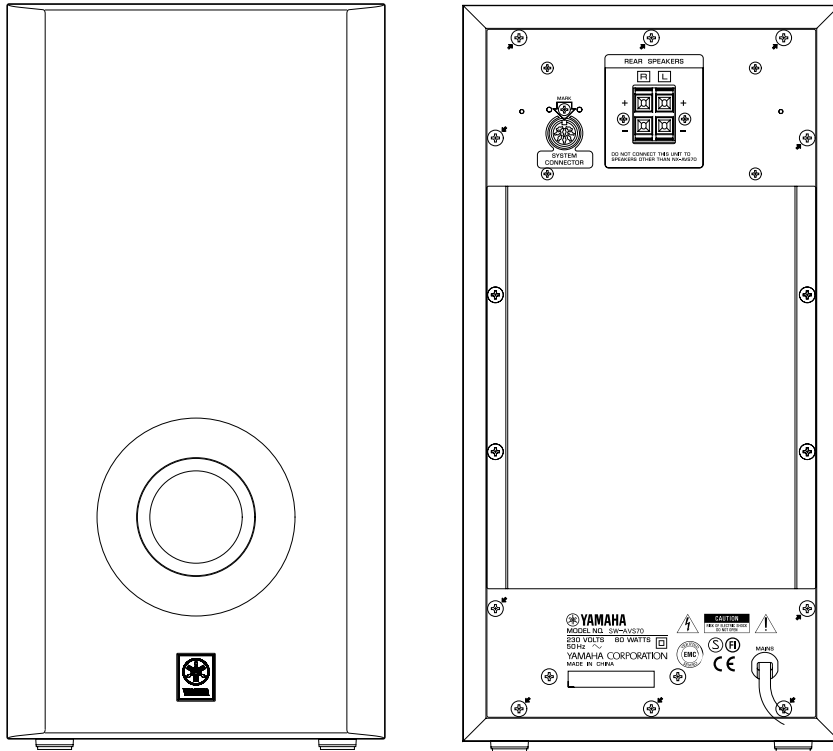

▼ NX-AVS70

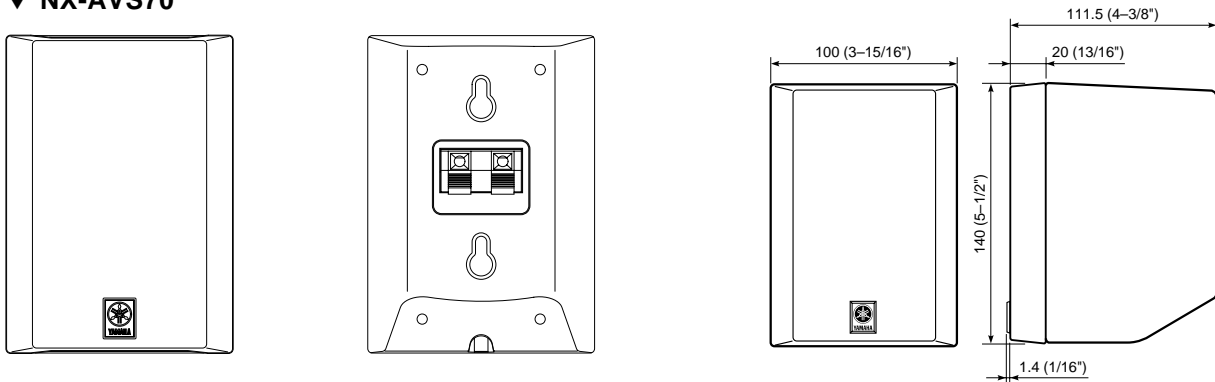

AV-S70/NX-SW70

■ SPECIFICATIONS

AV-S70

■ AMPLIFIER SECTION

Minimum RMS Output Power per Channel	
Front (1kHz, 10% THD, 6Ω)	30W + 30W
Signal to Noise Ratio (IHF-A-Network)	
TV	85dB
Total Harmonic Distortion (1kHz)	
TV to Speaker Out, 12.5W/6Ω	0.08%
Input Sensitivity/Impedance	
TV	200mV/50kΩ

■ SPEAKER SECTION

Type	Bass reflex type
Speakers	8cm (3-1/8") cone x 2 (Magnetic-Shielding Type)
Maximum Power Handling Capacity	30W x 2
Impedance	6Ω

■ GENERAL

Power Supply	AC230V, 50Hz
Power Consumption	68W
Dimensions (W X H X D)	600 X 110 X 243mm (23-5/8" X 4-5/16" X 9-9/16")
Weight	7.0kg (15 lbs. 7 oz)
Finish	Gray color
Accessories	Pin Cord (RCA) X 1 Remote Control Transmitter X 1 Battery (size "AAA", R03) X 4 Fastener Tape X 2

* Specifications subject to change without notice.

NX-SW70

■ AMPLIFIER SECTION

Minimum RMS Output Power per Channel	
Rear (1kHz, 10% THD, 6Ω)	30W + 30W
Sub Woofer (100Hz, 10% THD, 4Ω)	50W

■ REAR SPEAKER SECTION (NX-AVS70)

Type	Closed cabinet type
Speakers	8cm (3-1/8") cone (Magnetic-Shielding Type)
Maximum Power Handling Capacity	30W
Impedance	6Ω
Dimensions (W X H X D)	100 X 140 X 113mm (3-15/16" X 5-1/2" X 4-7/16")
Weight	0.7kg (1 lbs. 8 oz)
Finish	Gray color

■ SUB WOOFER SPEAKER SECTION (SW-AVS70)

Type	Advanced Active Servo Technology type
Speakers	16cm (6-5/16") cone (Magnetic-Shielding Type)
Maximum Power Handling Capacity	50W
Impedance	4Ω
Dimensions (W X H X D)	200 X 395 X 399mm (7-7/8" X 15-9/16" X 15-11/16")
Weight	9.7kg (21 lbs. 6 oz)
Finish	Gray color

■ GENERAL

Power Supply	AC230V, 50Hz
Power Consumption	80W
Accessories	System Cord (DIN plug) X 1 Speaker Cable (15m) X 2 Wall Bracket X 2 Bracket X 2 Wing Bolt X 2 Screw X 2

* Specifications subject to change without notice.

G European model
B British model

* **(●)TruBass™**

TruBass and the (●) symbol are trademarks of SRS Labs, inc. in the United States and selected foreign countries. TruBass technology is incorporated under license from SRS Labs, inc.

Manufactured under license from Dolby Laboratories. "Dolby", "Dolby Digital", "Pro Logic", and the double-D symbol  are trademarks of Dolby Laboratories. © 1992-1997 Dolby Laboratories. All rights reserved.

AV-S70 DISASSEMBLY PROCEDURES (Remove parts in the order as numbered.)

1. Removal of Grille Assembly.

- a. Push up the Grille Assembly with a flat tip screwdriver or the like inserted from the bottom. (Fig. 1).
- b. Keep pushing up the Grille Assembly gradually until it can be removed.
- * **The Grille Assembly is fixed securely at 8 dowels. When removing it, use care not to cause a scratch or any damage to the main unit. When reinstalling it, apply quick-drying type bond to the dowels of the Grille Assembly and fit it in place securely. (If it is only pushed in, it will come off easily.)**

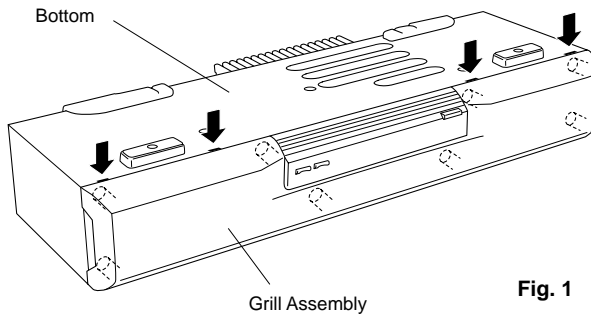

Fig. 1

2. Removal of Amplifier Unit

- a. Remove 4 wing screws (①) and then remove the Plate Legs (right and left). (Fig. 2)
- b. Remove 4 screws (②). (Fig. 2)
- c. Remove 7 screws (③) and then remove the Amplifier Unit. (Fig. 2)
- * **Arrow marks are printed to identify the screws to be removed.**

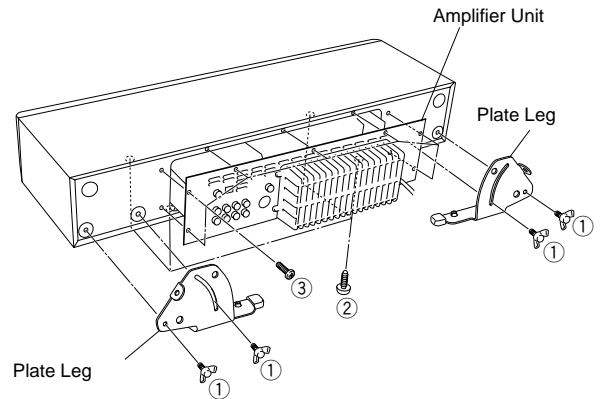

Fig. 2

SW-AVS70 DISASSEMBLY PROCEDURES (Remove parts in the order as numbered.)

a. Removal of Grille Assembly.

- a. Push up the Grille Assembly with a flat tip screwdriver or the like inserted from the bottom. (Fig. 3).
- b. Keep pushing up the Grille Assembly gradually until it can be removed.
- * **The Grille Assembly is fixed securely at 6 dowels. When removing it, use care not to cause a scratch or any damage to the main unit. When reinstalling it, apply quick-drying type bond to the dowels of the Grille Assembly and fit it in place securely. (If it is only pushed in, it will come off easily.)**

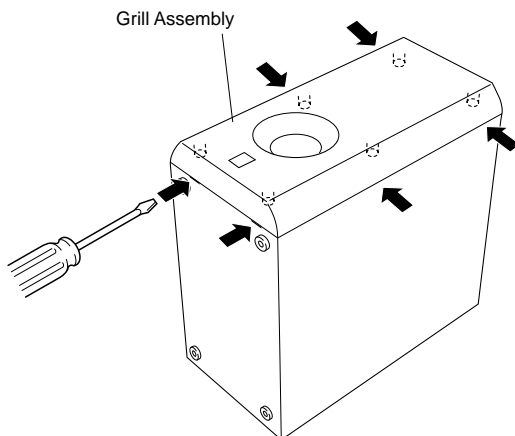

Fig. 3

2. Removal of Amplifier Unit

- a. Remove 14 screws (④) and then remove the Amplifier Unit. (Fig. 4)
- * **Arrow marks are printed to identify the screws to be removed.**

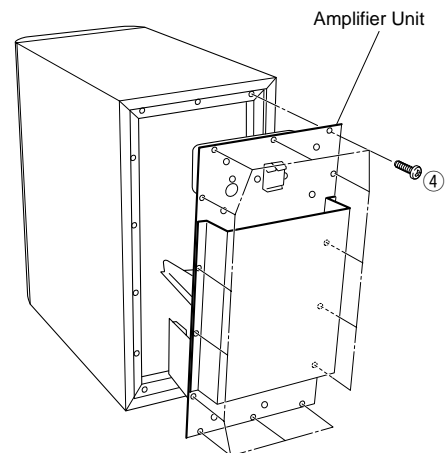

Fig. 4

■ TEST PROGRAM MODE (AV-S70)

1. Procedure for starting Test Program

With the power turned off, press the POWER key while pressing the VOLUME key and the DSP key simultaneously. This initiates the Test Program function.

When the Test Program is initiated, "01 DEST-Ex" appears on the FL display.

2. Procedure for selecting and executing Test Program

Using the VOLUME + (UP) key and Volume - (DOWN) key, select the Test Program and then press the INPUT key to execute it.

3. Procedure for canceling Test Program

There are two methods for cancellation.

- Turn off the power by pressing the POWER key of the main unit or the remote controller.
- Select the Test Program "01 DEST-Ex" and press the INPUT key for execution. (The normal mode will be restored.)

4. Details of the Test Program function

Display	Function
01 DEST-B,G1	Destination display/ test program end Destination display J:Ja J (Japanese) J:En J (English) B,G1 B, G models
02 FL+CLEAR	FL display segments all light up / BACKUP RAM CLEAR 1 st time: FL display segments all light up and standby LED lights up. 2 nd time: RAM CLEAR is executed (RAM CLEAR OK on display) * State before shipped out of the factory preset.
03 FL CHECK	FL display light-up check 1 st time: FL display segments all light up and standby LED lights up. 2 nd time: Even number segments and digits light up. 3 rd time: Odd number segments and digits light up.

1st time



2nd time



3rd time



AV-S70/NX-SW70

Display	Function
04 DSP Diag	The DSP DIAG (self-diagnosis) mode is initiated. (Refer to page 7 for the details.)
05 Ver-A1.08	<p>Microprocessor version / date display</p> <p>Example of microprocessor display 05 Ver-A1.08</p> <p>Example of microprocessor date display 05 '99.10.15</p> <p>What is displayed varies depending on the microprocessor software.</p>
06 SUM[47a0]	Check sum calculation display / re-calculation
07 PrCan-OFF	All protection cancellation function ON/OFF
08 Pr!C_P_S_	<p>Protection operation history display / clear</p> <p>C: Center unit amplifier voltage</p> <p>P: Power circuit voltage</p> <p>S: Switch side</p> <p>_: Normal</p> <p>x: Abnormal</p>
09 Cors- St.	<p>ROM collection (EEPROM) check sum calculation/calculation start</p> <p>When there is a data in the ROM collection area of EEPROM:</p> <p>Example of display 09 Cors-288b</p> <p>When there is no data, "NON" appears on the display.</p> <p>* The ROM collection (EEPROM) is utilized to cope with the data area for backup and microprocessor bugs partially. The backup memory for the sound field or the like will be retained semi-permanently even when the plug is disconnected. No data is written in the parts mounted on the product as single units.</p>
10 COR-Clear	<p>ROM collection (EEPROM) data clear / clear start</p> <p>Display is provided only when there is data in the ROM collection area of EEPROM</p> <p>1st time: Data clear confirmation (Clear-ON? displayed)</p> <p>2nd time: Data clear execution (Clear:OK! displayed)</p> <p>After "Clear-ON?" is displayed, do not use INPUT key for execution (because the program contents will be erased).</p> <p>Using VOLUME + (UP) key and VOLUME - (DOWN) key, select another test program.</p> <p>* The IC for ROM collection has a role to help the microprocessor be upgraded. If the written data is cleared, the old version will be restored.</p>

■ DSP DIAG MODE (Self-diagnosis)

Use the remote controller supplied as an accessory to select the menu.

1. Procedure for starting DSP DIAG

Referring to TEST PROGRAM MODE in the previous section, select/execute "04 DSP Diag".

When "04 DSP Diag" is executed, the current input name appears on the display followed by "Video" > "Sel.1to9 Key".
(The DSP indicator keeps flashing.)

2. Procedure for selecting Main menu and Sub-menu

Using [1] through [9] keys on the remote controller, select the main menu. Soon the sub-menu will appear on the display. Then, select the sub-menu. Every time the selected key (on the remote controller) is pressed, the sub-menu on the display changes.

No.	Main menu	(Display)	Sub-menu	(Display)
1	Analog through	Analog Thr.	MAIN BYPASS	A.T.M.ByPass
			DSP 0dB	A.T. DSP 0dB
2	DSP through	Dsp Through	YSS908-SRAM	DspT.908SRAM
			YS908	DspT.YSS908
			DSP FULL BIT	DspT.FullBit
3	AC-3 through	AC-3 Through	Status (Binary)	AC3 Analo2/0
4	Pro logic	Pro Logic	CENTER LARGE	ProL.CenterL
			EFFECT OFF	ProL.Eff.Off
5	Speakers set	Speakers Set	MAIN : SMALL 0dB	Sp.MainS 0dB
			MAIN : LARGE 0dB	Sp.MainL 0dB
			LFE/BASS : MAIN	
			CENTER : NONE	Sp.Lfe:M C:N
			LFE/BASS : MAIN	Sp.LfeBass:M
			LFE/BASS : SWFR	Sp.Lfe:Swfr
			CENTER : NONE	Sp.Cent:None
			CENTER : SMALL	
6	Effect off	Effect Off	REAR : SMALL	Sp.Ce:S Re:S
			EFFECT OFF	Effect Off
7	Manual test	Manual Test	ALL	M.Test All
			MAIN L	M.Test Left
			CENTER	M.TestCenter
			MAIN R	M.Test Right
			REAR R	M.Test RearR
			REAR L	M.Test RearL
			LFE	M.Test Lfe
8		No function		
9		DIAG cancel		

3. Procedure for canceling DIAG

There are two methods for cancellation of DIAG.

- Turn off the power by pressing the [POWER] key of the main unit or the remote controller.
- Press the [9] key of the remote controller. (The normal mode will be restored.)

Details of DIAG menu

1. Analog Thr.

The input is fixed to use the analog (A/D) and has 2 sub-menu items.

MAIN BYPASS

The main L/R signal is output through the analog bypass without passing the DSP section.

The main L/R signal passing through the DSP is output through C/LFE and RL/RR.

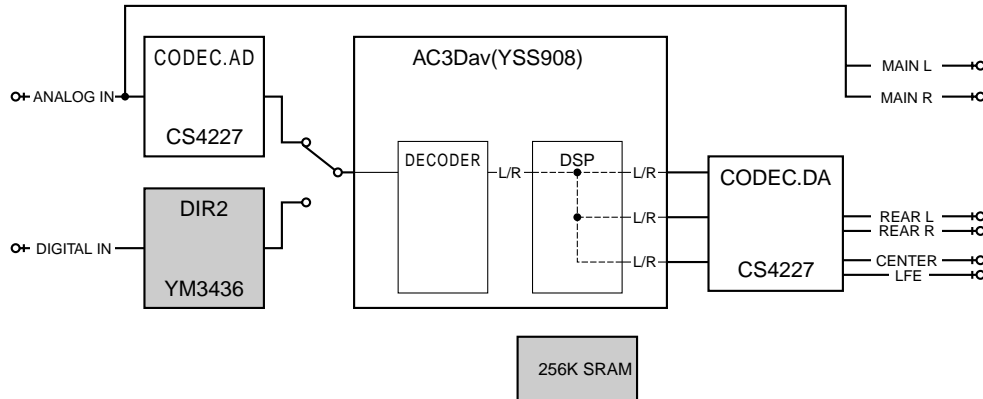

AUX IN : -20dBV, Both ch
 VOLUME : MAX

CN102 (Page 30, C-4)

MAIN L (1kHz) : -20dBV
 MAIN R (1kHz) : -20dBV
 LFE (30Hz) : -34dBV
 REAR L (1kHz) : -26dBV
 REAR R (1kHz) : -26dBV

The shaded square means that the element included in it does not operate.

DSP 0dB

The main L/R, C/LFE, RL/RR signals pass through the DSP section.

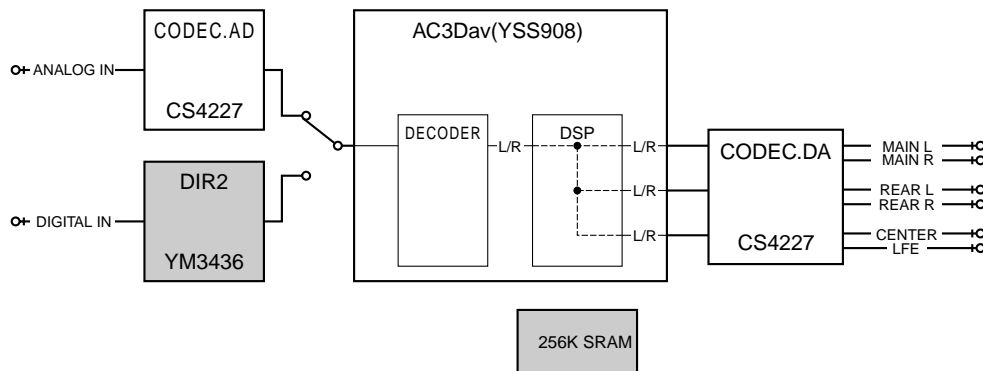

AUX IN : -20dBV, Both ch
 VOLUME : MAX

CN102 (Page 30, C-4)

MAIN L (1kHz) : -20dBV
 MAIN R (1kHz) : -20dBV
 LFE (30Hz) : -34dBV
 REAR L (1kHz) : -26dBV
 REAR R (1kHz) : -26dBV

The shaded square means that the element included in it does not operate.

2. DSP Through

In the DIGITAL input mode, AC3/PCM AUDIO signal is automatically identified. There are 3 sub-menu items.

YSS908-SRAM

The main L/R signal is sent through AC3D2av into DSP. After passing through SRAM, the main L/R signal is output through L+R and C/LFE and RL/RR signals through (L+R)/2.

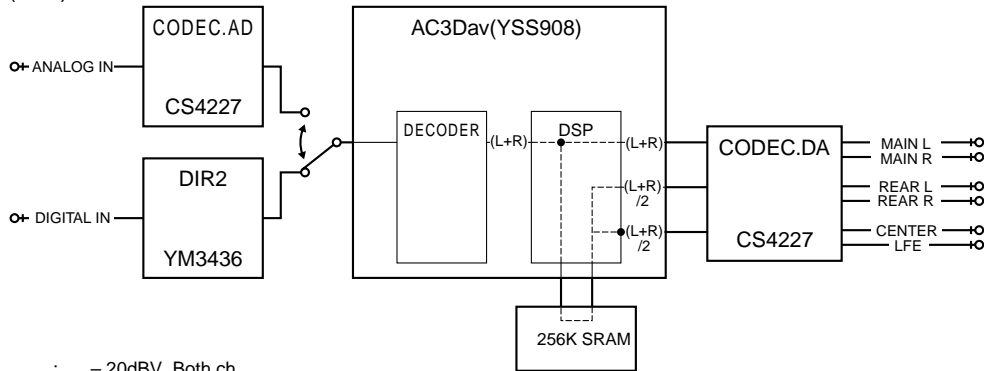

AUX IN : -20dBV, Both ch
 VOLUME : MAX

CN102 (Page 30, C-4)
 MAIN L (1kHz) : -20dBV
 MAIN R (1kHz) : -20dBV
 LFE (30Hz) : -34dBV
 REAR L (1kHz) : -26dBV
 REAR R (1kHz) : -26dBV

YSS908-SRAM

The main L/R signal is sent through AC3D2av into DSP. The main L/R signal is output through L+R and C/LFE and RL/RR signals through (L+R)/2.

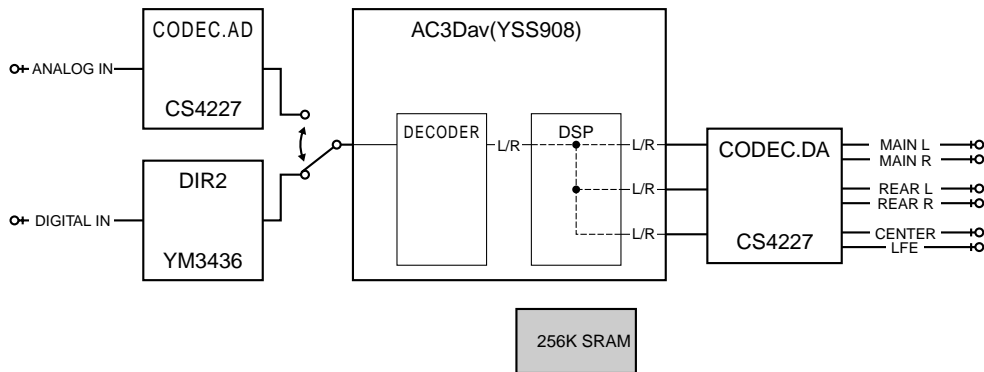

AUX IN : -20dBV, Both ch
 VOLUME : MAX

CN102 (Page 30, C-4)
 MAIN L (1kHz) : -20dBV
 MAIN R (1kHz) : -20dBV
 LFE (30Hz) : -34dBV
 REAR L (1kHz) : -26dBV
 REAR R (1kHz) : -26dBV

The shaded square means that the element included in it does not operate.

DSP FULL BIT

The main L/R is input through AC3D2av to DSP and then output through all channels. The head margin is eliminated and the digital data is output in digital full bit. The same applies as "YSS908" except that the digital data is output in full bit at D/A.

AUX IN : -20dBV, Both ch
 VOLUME : MAX

CN102 (Page 30, C-4)
 MAIN L (1kHz) : -11dBV
 MAIN R (1kHz) : -11dBV
 LFE (30Hz) : -13dBV
 REAR L (1kHz) : -17dBV
 REAR R (1kHz) : -17dBV

Full bit: The digital data is normally output with a head margin for each of C and RL/RR channels. In this menu, no head margin is used and the digital data is output in full bit so as to obtain the A/D and D/A characteristics fully. Note that this means the analog gain after D/A is larger as compared to L/R. Also, the LFE channel also outputs the signal in full bit.

3. AC-3 Through

Only the signal of the digital system is input. The AC3 signal is decoded and reproduced according to the input source.

The AC-3 signal in each channel is AC-3 decoded and output through AC3D2av. The combined status information of the sampling frequency and the number of channels of the AC3 signal appears on the FI display.

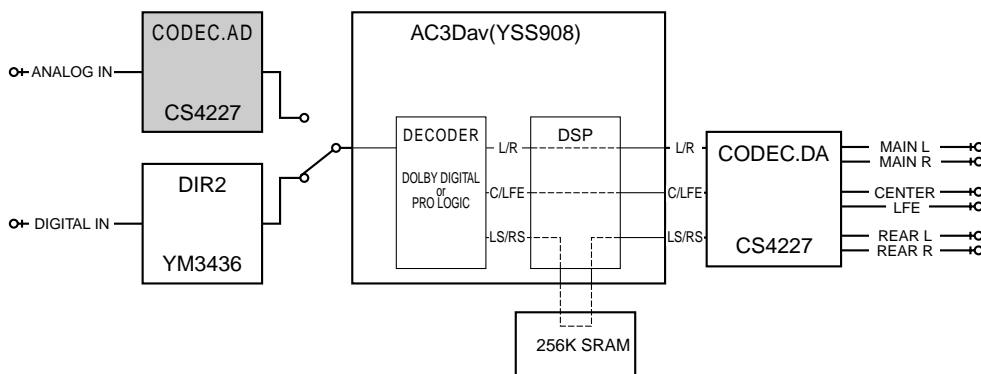

The shaded square means that the element included in it does not operate.

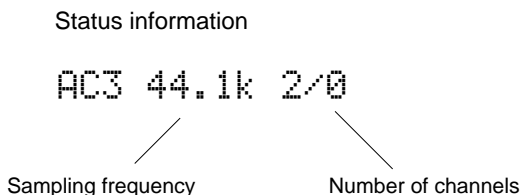

Sampling frequency	(Display)
Analog	Analo
32kHz	32k
44.1kHz	44.1k
48kHz	48k

Number of channels (Front/Rear)	(Display)
1+1	1+1
1/0	1/0
2/0	2/0
3/0	3/0
2/1	2/1
3/1	3/1
2/2	2/2
3/2 5.1ch	3/2
7.1 (DTS)	7.1

As signal identification is executed in normal AC-3 reproduction, the source (DAT, CD-ROM, etc) without digital data bit of IEC958 cannot be reproduced even when it is AC-3 encoded. On the other hand, as this menu does not execute such digital data bit identification, these sources can be AC-3 reproduced. (To measure characteristics during AC-3 reproduction, use the AC-3 decoded sine wave.)

However, note that with the sources that have not been AC-3 encoded, a decode error occurs and muting is applied. In addition, by displaying the combined status information of the sampling frequency and the number of channels of the AC-3 signal on the FL display, malfunction of the decoder can be detected.

4. Pro Logic

The sub-menu items include selection of Pro-logic (The auto input balance is off.) and EFFECT OFF.

CENTER LARGE

When the analog, PCM audio or AC-3 2/0 mode is used, L, R, C, S signals are pro-logic decoded and output. When the AC-3 mode other than 2/0 is used, the pro logic function does not work and the signals are AC-3 reproduced.

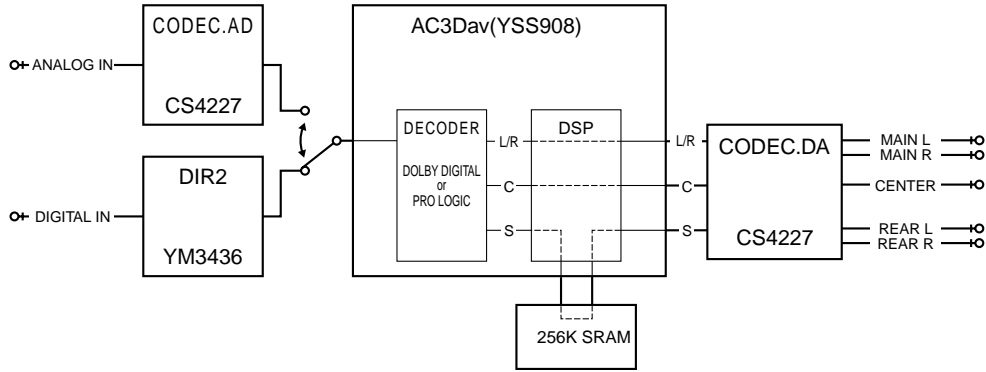

AUX IN : -20dBV, Both ch
 VOLUME : MAX

CN102 (Page 30, C-4)

MAIN L (1kHz) : -20dBV
 MAIN R (1kHz) : -20dBV
 LFE (30Hz) : -28dBV
 REAR L (1kHz) : < -45dBV
 REAR R (1kHz) : < -45dBV

AUX IN : -20dBV, L ch only
 VOLUME : MAX

CN102 (Page 30, C-4)

MAIN L (1kHz) : -20dBV
 MAIN R (1kHz) : < -45dBV
 LFE (30Hz) : -32dBV
 REAR L (1kHz) : < -45dBV
 REAR R (1kHz) : < -45dBV

EFFECT OFF

The L/R signal is output through MAIN BYPASS.

5. Speakers Set (for reference only)

This menu is for checking during the production process and not for servicing.

The input L/R signal is output through the specified channels according to the sub-menu.

There are 7 sub-menu items.

The signal output from the DSP section is normally in the EFFECT OFF state in the menus from 1 to

3. In the menus after that, the same signal as in the menu of 2. DSP THROUGH: YSS908 is output.

The analog switch settings in each sub-menu are as shown in the following table.

Sub-menu		Output										
		CENTER	REAR	MAIN	MAIN LEVEL	LFE/BASS	MAIN L	MAIN R	CENTER	REAR L	REAR R	SUBWOOFER
1	MAIN : SMALL 0dB	LARGE	LARGE	SMALL	0dB	SWFR	L	R	X	X	X	L+R
2	MAIN : LARGE 0dB	LARGE	LARGE	LARGE	0dB	SWFR	L	R	X	X	X	X
3	LFE/BASS : MAIN CENTER : NONE	NONE	LARGE	LARGE	0dB	MAIN	L	R	X	X	X	X
4	LFE/BASS : MAIN	LARGE	LARGE	LARGE	0dB	MAIN	LFE+FL	LFE+FR	X	X	X	X
5	LFE/BASS : SUBWOOFER	LARGE	LARGE	LARGE	0dB	SWFR	X	X	X	X	X	LFE
6	CENTER : NONE	NONE	LARGE	LARGE	0dB	SWFR	C+FL	C+FR	X	X	X	X
7	CENTER : SMALL REAR : SMALL	SMALL	SMALL	LARGE	0dB	SWFR	FL	FR	C	RL	RR	C+RL+RR+LFE

* In Sub-menu 1, the lower range content of the MAIN L/R is output at SWFR as well.

* In Sub-menu 7, the lower range content of LFE, CENTER and REAR is output at SWFR as well.

LARGE: Signals are output in all bandwidths.

SMALL: Only signals lower than 90Hz are mixed in the channel specified by LFE/BASS.

NONE: The center contents are distributed to the MAIN L/R channels after -3dB.

SWFR: SUBWOOFER

Output: The signal before MASTER VOLUME is indicated.

Sub-menu	Main application
MAIN : SMALL 0dB	Confirmation of high/low pass filter characteristics and gain when BASS REDIRECTION is used.
MAIN : LARGE 0dB	Reference for Sub-menu 1 and 2
LFE/BASS : MAIN CENTER : NONE	Confirmation of effect of the mix circuit to the main channel.
LFE/BASS : MAIN	Confirmation of gain of BASS MIX.
LFE/BASS : SWFR	Confirmation of the maximum output of LFE.
CENTER : NONE	Confirmation of gain of CENTER MIX.
CENTER : SMALL REAR : SMALL	Confirmation of high/low pass filter characteristics and gain when BASS REDIRECTION is used.

6. Effect Off

All effect functions are turned off.

7. Manual Test

The test noise is output by the noise generator with a built-in DSP through the channels specified by the sub-menu.

- ALL Noise is output through all channels.
- MAIN L Noise is output through the MAIN L channel.
- CENTER Noise is output through the CENTER channel.
- MAIN R Noise is output through the MAIN R channel.
- REAR R Noise is output through the REAR R channel.
- REAR L Noise is output through the REAR L channel.
- LFE Noise is output through the LFE (sub-woofer) channel.

8. No function

9. DIAG cancel

The DSP DIAG is canceled.

AV-S70 IC DATA

IC701 : M30218FCFP (16 bit μ-COM)

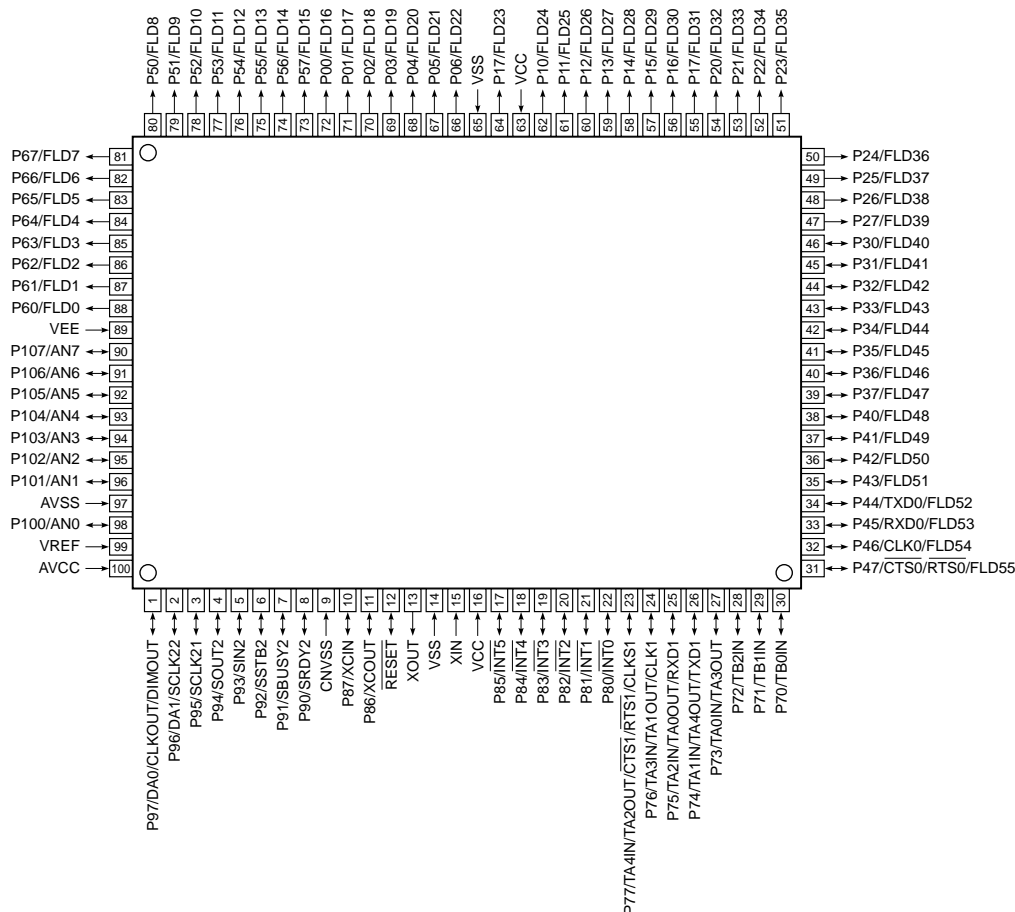

No.	PORT	Name	IN/OUT	Function
1	P97	CMOS	OUT	BASS BOOST OUT [0:ON]
2	P96	CMOS	OUT	Center unit, RL,RR,SW MUTE OUT [0:MUTE ON]
3	P95	CMOS	OUT	(DSP) SERIAL/CODEC CLK OUT (SCK)
4	P94	CMOS	OUT	(DSP) SERIAL/CODEC DATA OUT (SDT)
5	P93	CMOS	OUT	(DSP) DIR2 CCK (CCK)
6	P92	CMOS	OUT	(DSP) DIR2 CLD (CLD)
7	P91	CMOS	OUT	(DSP) AC3D CE1 OUT (CEAC1)
8	P90	CMOS	OUT	(DSP) AC3D CE2 OUT (CEAC2)
9	CNVSS	-	-	Connected to VSS (GND) via a resistance (5.1kΩ)
10	P87	CMOS	OUT	Switching of analog input selector (4052) to A OUT A B [00:GND 01:TV]
11	P86	CMOS	OUT	Switching of analog input selector (4052) to B OUT [10:AUX 11:VCR]
12	RESET	-	-	RESET [0:RESET]
13	XOUT	-	-	10 MHz IN (Feedback resistance included)
14	VSS	-	-	GND
15	XIN	-	-	10 MHz IN (Feedback resistance included)
16	VCC	-	-	+5V power supply
17	P85	INT5	INT-IN	(DSP) DIR2 ERR IN (ERRD)
18	P84	INT4	INT-IN	(DSP) AC3D MUTE IN (ERRA)
19	P83	(INT3)	IN	(DSP) DIR2 CD0 IN (CD0)
20	P82	(INT2)	IN	Center unit amplifier voltage detect IN (Protection) [0: abnormality exists]
21	P81	INT1	INT-IN	Remote controller IN
22	P80	INT0	INT-IN	Power down DC detect IN [0:POWER DOWN]

IC701 : M30218FCFP (16 bit μ -COM)

No.	PORT	Name	IN/OUT	Function
23	P77	CMOS	OUT	(DSP) /IC AC3D OUT (/ICAC)
24	P76	CLK1	S-CLK	(DSP) AC3D CLK OUT(CLKAC) (Serial I/O-1)
25	P75	RxD1	S-IN	(DSP) AC3D DATA IN(RXAC) (Serial I/O-1)
26	P74	TxD1	S-OUT	(DSP) AC3D DATA OUT(TXAC) (Serial I/O-1)
27	P73	CMOS	OUT	(DSP) CODEC CE OUT (CECOD)
28	P72	CMOS	OUT	Analog switch (LC78212) CE OUT [0: Address 1: Data]
29	P71	CMOS	OUT	Electronic VR (TC9482) STB OUT [1:ON]
30	P70	CMOS	OUT	CE OUT to E2PROM [1: DATA transfer]
31	P47	CTS0	OUT	TruBass Switching OUT/Busy OUT to flash writer [1:ON]
32	P46	CLK0	S-CLK	LC78212/TC9482/CLK OUT to E2PROM/CLK IN from flash writer (Serial I/O-0)
33	P45	RxD0	S-IN	DATA IN from E2PROM/DATA IN from flash writer (Serial I/O-0)
34	P44	TxD0	S-OUT	LC78212/TC9482/DATA OUT to E2PROM/DATA OUT from flash writer (Serial I/O-0)
35	P43	P-OD	OUT	SW primary power supply relay control OUT [0:ON]
36	P42	P-OD	OUT	6ch speaker relay control OUT [1:ON]
37	P41	-	IN	SW PRE OUT in use/unused IN [1: in use]
38	P40	P-OD	OUT	STANDBY LED OUT [1: light up]
39	P37	FLD47	OUT	DIGIT 13 (13G) [VEE external pull-down required]
40	P36	FLD46	OUT	DIGIT 12 (12G) [VEE external pull-down required]
41	P35	FLD45	OUT	DIGIT 11 (11G) [VEE external pull-down required]
42	P34	FLD44	OUT	DIGIT 10 (10G) [VEE external pull-down required]
43	P33	FLD43	OUT	DIGIT 9 (9G) [VEE external pull-down required]
44	P32	FLD42	OUT	DIGIT 8 (8G) [VEE external pull-down required]
45	P31	FLD41	OUT	DIGIT 7 (7G) [VEE external pull-down required]
46	P30	FLD40	OUT	DIGIT 6 (6G) [VEE external pull-down required]
47	P27	FLD39	OUT	DIGIT 5 (5G) [VEE external pull-down required]
48	P26	FLD38	OUT	DIGIT 4 (4G) [VEE external pull-down required]
49	P25	FLD37	OUT	DIGIT 3 (3G) [VEE external pull-down required]
50	P24	FLD36	OUT	DIGIT 2 (2G) [VEE external pull-down required]
51	P23	FLD35	OUT	DIGIT 1 (1G) [VEE external pull-down required]
52	P22	FLD34	OUT	SEGMENT 1 (P1) [VEE external pull-down required]
53	P21	FLD33	OUT	SEGMENT 2 (P2) [VEE external pull-down required]
54	P20	FLD32	OUT	SEGMENT 3 (P3) [VEE external pull-down required]
55	P17	FLD31	OUT	SEGMENT 4 (P4) (VEE internal pull-down)
56	P16	FLD30	OUT	SEGMENT 5 (P5) (VEE internal pull-down)
57	P15	FLD29	OUT	SEGMENT 6 (P6) (VEE internal pull-down)
58	P14	FLD28	OUT	SEGMENT 7 (P7) (VEE internal pull-down)
59	P13	FLD27	OUT	SEGMENT 8 (P8) (VEE internal pull-down)
60	P12	FLD26	OUT	SEGMENT 9 (P9) (VEE internal pull-down)
61	P11	FLD25	OUT	SEGMENT 10 (P10) (VEE internal pull-down)
62	P10	FLD24	OUT	SEGMENT 11 (P11) (VEE internal pull-down)
63	VCC	-	-	+5V power supply
64	P07	FLD23	OUT	SEGMENT 12 (P12) (VEE internal pull-down)
65	VSS	-	-	GND
66	P06	FLD22	OUT	SEGMENT 13 (P13) (VEE internal pull-down)
67	P05	FLD21	OUT	SEGMENT 14 (P14) (VEE internal pull-down)
68	P04	FLD20	OUT	SEGMENT 15 (P15) (VEE internal pull-down)
69	P03	FLD19	OUT	SEGMENT 16 (P16) (VEE internal pull-down)
70	P02	FLD18	OUT	SEGMENT 17 (P17) (VEE internal pull-down)
71	P01	FLD17	OUT	SEGMENT 18 (P18) (VEE internal pull-down)
72	P00	FLD16	OUT	SEGMENT 19 (P19) (VEE internal pull-down)
73	P57	FLD15	OUT	SEGMENT 20 (P20) (VEE internal pull-down)
74	P56	FLD14	OUT	SEGMENT 21 (P21) (VEE internal pull-down)
75	P55	FLD13	OUT	SEGMENT 22 (P22) (VEE internal pull-down)
76	P54	FLD12	OUT	SEGMENT 23 (P23) (VEE internal pull-down)
77	P53	FLD11	OUT	SEGMENT 24 (P24) (VEE internal pull-down)

IC701 : M30218FCFP (16 bit μ -COM)

No.	PORT	Name	IN/OUT	Function	
78	P52	FLD10	OUT	SEGMENT 25 (P25)	(VEE internal pull-down)
79	P51	FLD9	OUT	SEGMENT 26 (P26)	(VEE internal pull-down)
80	P50	FLD8	OUT	SEGMENT 27 (P27)	(VEE internal pull-down)
81	P67	FLD7	OUT	SEGMENT 28 (P28)	(VEE internal pull-down)
82	P66	FLD6	OUT	SEGMENT 29 (P29)	(VEE internal pull-down)
83	P65	FLD5	OUT	SEGMENT 30 (P30)	(VEE internal pull-down)
84	P64	FLD4	OUT	SEGMENT 31 (P31)	(VEE internal pull-down)
85	P63	FLD3	OUT	SEGMENT 32 (P32)	(VEE internal pull-down)
86	P62	FLD2	OUT	SEGMENT 32 (P33)	(VEE internal pull-down)
87	P61	FLD1	OUT	SEGMENT 34 (P34)	(VEE internal pull-down)
88	P60	FLD0	OUT	SEGMENT 35 (P35)	(VEE internal pull-down)
89	VEE	-	-	P0, P1, P5, P6 pull-down resistance voltage input	[-29V]
* 90	P107	AN7	A-D IN	SW protection IN	[4.0-5.0V:SW provided, 2.5V:SW not provided, 0-2.0V:SW protection ON]
91	P106	AN6	A-D IN	AUTO POWER ON/OFF identify IN (music signal)	[0 — VREF]
92	P105	AN5	A-D IN	Center unit power supply voltage detect IN (protection)	[0 — VREF]
93	P104	CMOS	OUT	Night mode switching OUT	[1:ON]
94	P103	CMOS	OUT	Center unit power supply OUT	[1:ON]
95	P102	AN2	A-D IN	Destination select input	[Pull-up with 10k Ω > VREF]
96	P101	AN1	A-D IN	KEY 1 input	[Pull-up with 10k Ω > VREF]
97	AVSS	-	-	Connected to VSS (GND)	
98	P100	AN0	A-D IN	KEY O input	[Pull-up with 10k Ω > VREF]
99	VREF	-	-	A-D, D-A reference voltage input	[— VCC]
100	AVCC	-	-	Connected to VCC terminal (+5V)	

● KEY input (A-C) Pull-up resistance 10k Ω

Ω	0	+2k	+1.8k	+2.4k	+3.9k	+5.6k	+10k	+24k
V	— 0.556	— 1.111	— 1.667	— 2.222	— 2.778	— 3.333	— 3.889	— 4.444
KEY 0 (98pin)	VOLUME ∨	VOLUME ∧	NO KEY	NO KEY	NO KEY	NO KEY	NO KEY	NO KEY
KEY 1 (96pin)	DSP	INPUT	NO KEY	NO KEY	NO KEY	NO KEY	NO KEY	NO KEY

● Destination select input (95 pin A-D) Pull-up resistance 10k Ω

Ω	16k	27k	51k
V	2.778 — 3.333	3.333 — 3.889	3.889 — 4.444
Destination	J model (English)	B, G models (English)	J model (Japanese)

For any voltage that is not within the above range, the applicable destination is EX (English).

* SYSTEM CONNECTOR (Pin 90 of IC701)

- Pin 3 of the system connector (CN602) detects if the subwoofer is equipped / not equipped / faulty.

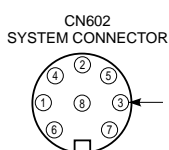

- When the system connector is connected correctly and the subwoofer is operating properly, approximately 4 to 5V voltage is obtained.
- When the system connector is not connected, approximately 2.5V voltage is obtained.
- When the protection circuit of the subwoofer is at work, approximately 0 to 2V voltage is obtained and the protection circuit of AV-S70 works together with it.

- When the system connector is not connected or the power of the subwoofer (NX-SW70) is not turned ON, only VIRTUAL SURROUND and MONO MOVIE functions of the sound field program are available.

IC3 : YM3436D

DIR (Digital Format Interface Receiver)

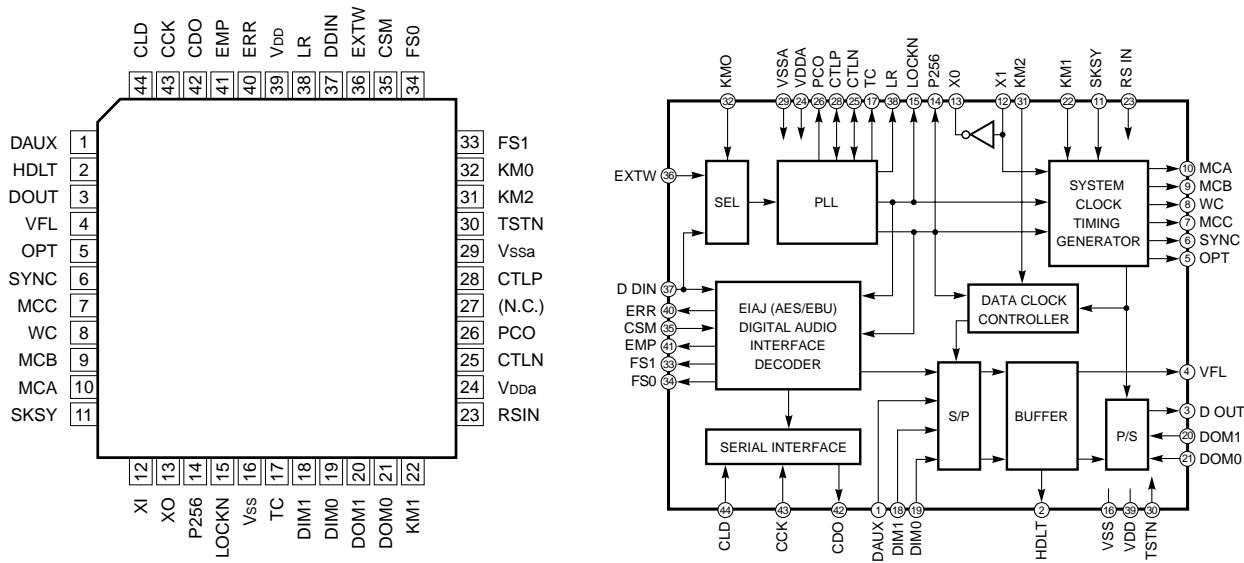

Pin No.	Pin Name	I/O	Function	Pin No.	Pin Name	I/O	Function
1	DAUX	I	Auxiliary input for audio data	26	PCO	O	PLL phase comparison output
2	HDLT	O	Asynchronous buffer operation flag	27	(NC)		
3	DOUT	O	Audio data output	28	CTLP	I	VCO control input P
4	VFL	O	Parity flag output	29	Vssa		VCO section power (GND)
5	OPT	O	Fs x 1 Synchronous output signal for DAC	30	TSTN	I	Test terminal. Open for normal use
6	SYNC	O	Fs x 1 Synchronous output signal for DSP	31	KM2	I	Clock mode switching input 2
7	MCC	O	Fs x 64Bit clock output	32	KM0	I	Clock mode switching input 0
8	WC	O	Fs x 1Word clock output	33	FS1	O	Channel status sampling frequency display output 1
9	MCB	O	Fs x 128Bit clock output	34	FS0	O	Channel status sampling frequency display output 0
10	MCA	O	Fs x 256Bit clock output	35	CSM	I	Channel status output method selection
11	SKSY	I	Clock synchronization control input	36	EXTW	I	External synchronous auxiliary input word clock
12	XI	I	Crystal oscillator connection or external clock input	37	DDIN	I	EIAJ (AES/EBU) data input
13	XO	O	Crystal oscillator connection	38	LR	O	PLL word clock output
14	P256	O	VCO oscillating clock connection	39	Vdd		Logic section power (+5V)
15	LOCKN	O	PLL lock flag	40	ERR	O	Data error flag output
16	Vss		Logic section power (GND)	41	EMP	O	Channel status emphasis control code output
17	TC	O	PLL time constant switching output	42	CD0	O	3-wire type microcomputer interface data output
18	DIM1	I	Data input mode selection	43	CCK	I	3-wire type microcomputer interface clock input
19	DIM0	I	Data input mode selection	44	CLD	I	3-wire type microcomputer interface load input
20	DOM1	I	Data output mode selection				
21	DOM0	I	Data output mode selection				
22	KM1	I	Clock mode switching input 1				
23	RSTN	I	System reset input				
24	Vdda		VCO section power (+5V)				
25	CTLN	I	VCO control input N				

AV-S70/NX-SW70

IC4 : YSS908-F
AC3Dav

No.	Name	I/O	Function
1	PVDD		+5V power supply
2	RAMCEN	O	External SRAM chip enable terminal
3	RAMA16	O	External SRAM address terminal 16
4	RAMA15	O	External SRAM address terminal 15
5	SDIB0	I	PCM input terminal 0 to Sub DSP
6	SDIB1	I	PCM input terminal 1 to Sub DSP
7	SDIB2	I	PCM input terminal 2 to Sub DSP
8	XI	I	Crystal oscillator connecting terminal (12.288MHz)
9	XO	O	Crystal oscillator connecting terminal
10	PVSS		Ground terminal (for digital)
11	AVDD		+3V power terminal (for analog)
12	TEST		Test terminal (unconnected)
13	TEST		Test terminal (unconnected)
14	TEST		Test terminal (unconnected)
15	OVFB	O	Sub DSP overflow detect terminal
16	TEST		Test terminal (unconnected)
17	TEST		Test terminal (unconnected)
18	TEST		Test terminal (unconnected)
19	CPO	O	PLL output terminal (connected to external analog filter circuit)
20	AVSS		Ground terminal (for PLL circuit)
21	VDD2		+3.3V power terminal (for internal circuit)
22	SDOA2	O	PCM output terminal from Main DSP (C/LFE output at AC-3/DTS, C/S output at Pro Logic)
23	SDOA1	O	PCM output terminal from Main DSP (LS/RS output at AC-3/DTS, Lt/Rt output at Pro Logic)
24	SDOA0	O	PCM output terminal from Main DSP (L/R output at both AC-3/DTS and Pro Logic)
25	RAMA14	O	External SRAM address terminal 14
26	RAMA13	O	External SRAM address terminal 13
27	RAMA12	O	External SRAM address terminal 12
28	RAMA11	O	External SRAM address terminal 11
29	RAMA10	O	External SRAM address terminal 10
30	VSS		Ground terminal (for internal circuit)
31	PVDD		+5V power terminal
32	OPORT0	O	General purpose output terminal (L/R ch is shifted by +3dB at Dolby Pro Logic)
33	OPORT1	O	General purpose output terminal (N.C.)
34	OPORT2	O	General purpose output terminal (N.C.)
35	OPORT3	O	General purpose output terminal (N.C.)
36	OPORT4	O	General purpose output terminal (N.C.)
37	OPORT5	O	General purpose output terminal (N.C.)
38	OPORT6	O	General purpose output terminal (N.C.)
39	OPORT7	O	General purpose output terminal (N.C.)
40	VSS		Ground terminal (for internal circuit)
41	VDD		+3V power terminal
42	RAMA9	O	External SRAM address terminal 9
43	RAMA8	O	External SRAM address terminal 8
44	RAMA7	O	External SRAM address terminal 7
45	SDOB2	O	PCM output terminal from Sub DSP
46	SDOB1	O	PCM output terminal from Sub DSP
47	SDOB0	O	PCM output terminal from Sub DSP
48	SDBCK1	I	Bit clock input terminal for SDOA, SDIB, SDOB signals
49	SDWCK1	I	Word clock input terminal for SDOA, SDIB, SDOB signals
50	VSS		Ground terminal
51	VDD		+3V power terminal
52	AC3DATA	O	AC-3 data output terminal, AC-3 bit stream data detect

IC4 : YSS908-F
AC3Dav

No.	Name	I/O	Function
53	CRC	O	AC-3 CRC error detect terminal
54	MUTE	O	Auto mute detect terminal
55	KARAOKE	O	AC-3 KARAOKE data detect terminal
56	SURENC	O	AC-3 2/0 mode Dolby surround encode input detect terminal
57	/SDBCK0	O	SDBCK0 invert clock output terminal
58	RAMA6	O	External SRAM address terminal 6
59	RAMA5	O	External SRAM address terminal 5
60	VSS		Ground terminal
61	RAMA4	O	External SRAM address terminal 4
62	/IC	I	Initial clear terminal
63	TEST		Test terminal (unconnected)
64	RAMA3	O	External SRAM address terminal 3
65	/CSB	I	Sub DSP chip select input terminal
66	/CS	I	Microprocessor interface chip select input terminal
67	SO	O	Microprocessor interface data output terminal
68	SI	I	Microprocessor interface and Sub DSP data input terminal
69	SCK	I	Microprocessor interface and Sub DSP clock input terminal
70	RAMA2	O	External SRAM address terminal 2
71	PVDD		+5V power terminal
72	RAMD0	I/O	External SRAM data terminal (STREAM 0 output when external SRAM is not used)
73	RAMD1	I/O	External SRAM data terminal (STREAM 1 output when external SRAM is not used)
74	RAMD2	I/O	External SRAM data terminal (STREAM 2 output when external SRAM is not used)
75	RAMD3	I/O	External SRAM data terminal (STREAM 3 output when external SRAM is not used)
76	RAMD4	I/O	External SRAM data terminal (STREAM 4 output when external SRAM is not used)
77	RAMD5	I/O	External SRAM data terminal (STREAM 5 output when external SRAM is not used)
78	RAMD6	I/O	External SRAM data terminal (STREAM 6 output when external SRAM is not used)
79	RAMD7	I/O	External SRAM data terminal (STREAM 7 output when external SRAM is not used)
80	PVSS		Ground terminal
81	VDD2		+3V power terminal
82	SDWCK0	I	Word clock input terminal for SDIA, SDOA, SDIB and SDOB signals
83	SDBCK0	I	Bit clock input terminal for SDIA, SDOA, SDIB and SDOB signals
84	SDIA0	I	AC-3/DTS bit stream (or PCM) data input terminal to Main DSP
85	SDIA1	I	AC-3/DTS bit stream (or PCM) data input terminal to Main DSP
86	RAMA1	O	External SRAM address terminal 1
87	RAMA0	O	External SRAM address terminal 0
88	RAMWEN	O	External SRAM write enable terminal
89	RAMOEN	O	External SRAM output enable terminal
90	VSS		Ground terminal
91	VDD		+3V power terminal
92	IPOINT7	I	General purpose input terminal (GND)
93	IPOINT6	I	General purpose input terminal (GND)
94	IPOINT5	I	General purpose input terminal (GND)
95	IPOINT4	I	General purpose input terminal (GND)
96	IPOINT3	I	General purpose input terminal (GND)
97	IPOINT2	I	General purpose input terminal (GND)
98	IPOINT1	I	General purpose input terminal (GND)
99	IPOINT0	I	General purpose input terminal (GND)
100	VSS		Ground terminal

AV-S70 BLOCK DIAGRAM (1/2)

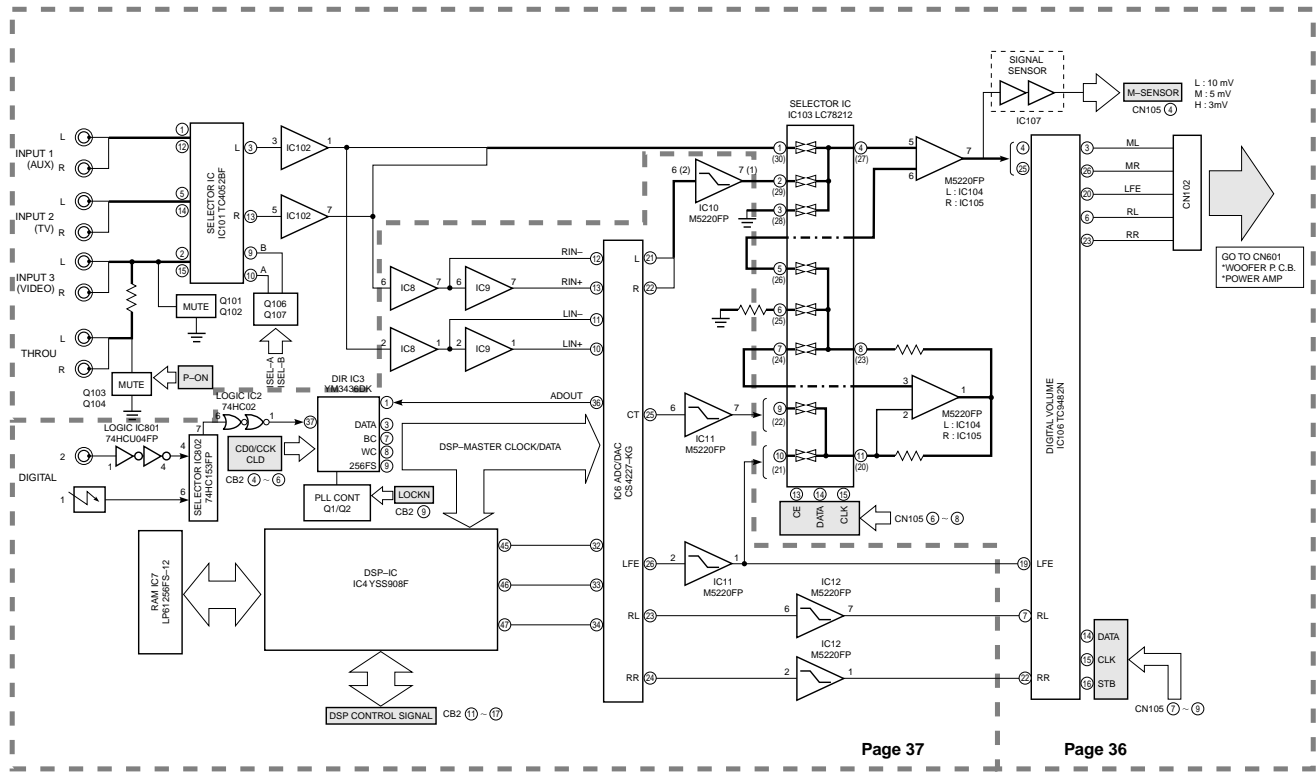

Page 37

Page 36

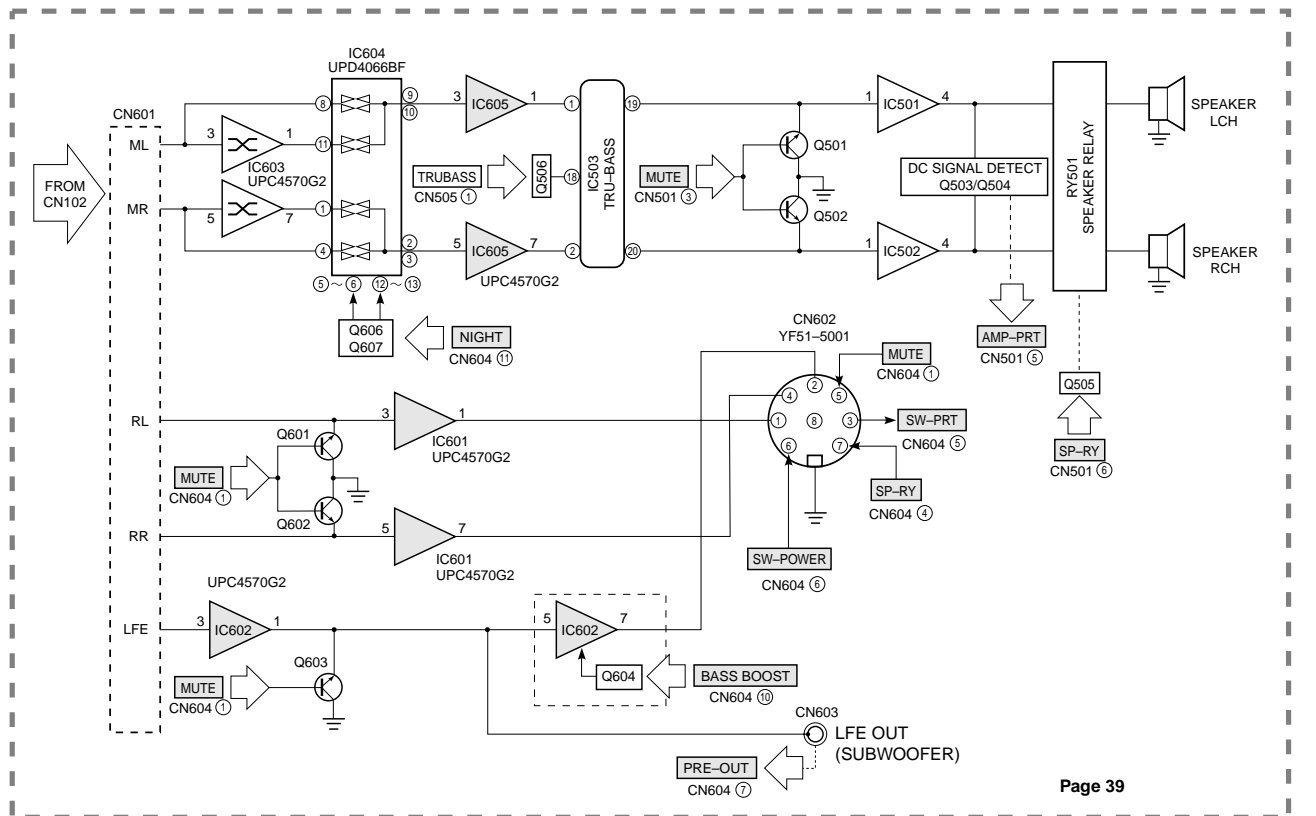

Page 39

AV-S70/NX-SW70

AV-S70 BLOCK DIAGRAM (2/2)

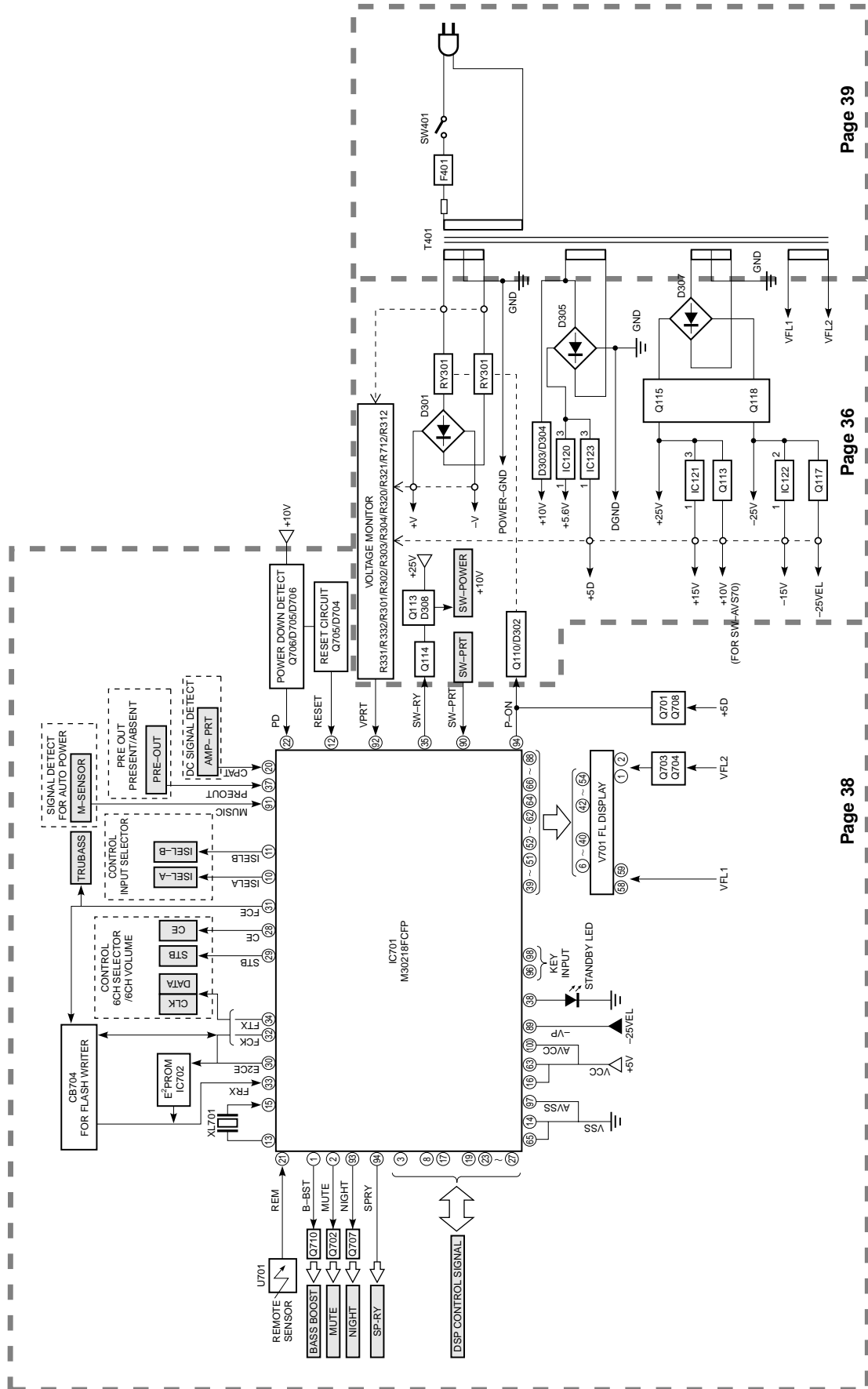

Page 39

Page 36

Page 38

AV-S70/NX-SW70

SW-AVS70 BLOCK DIAGRAM

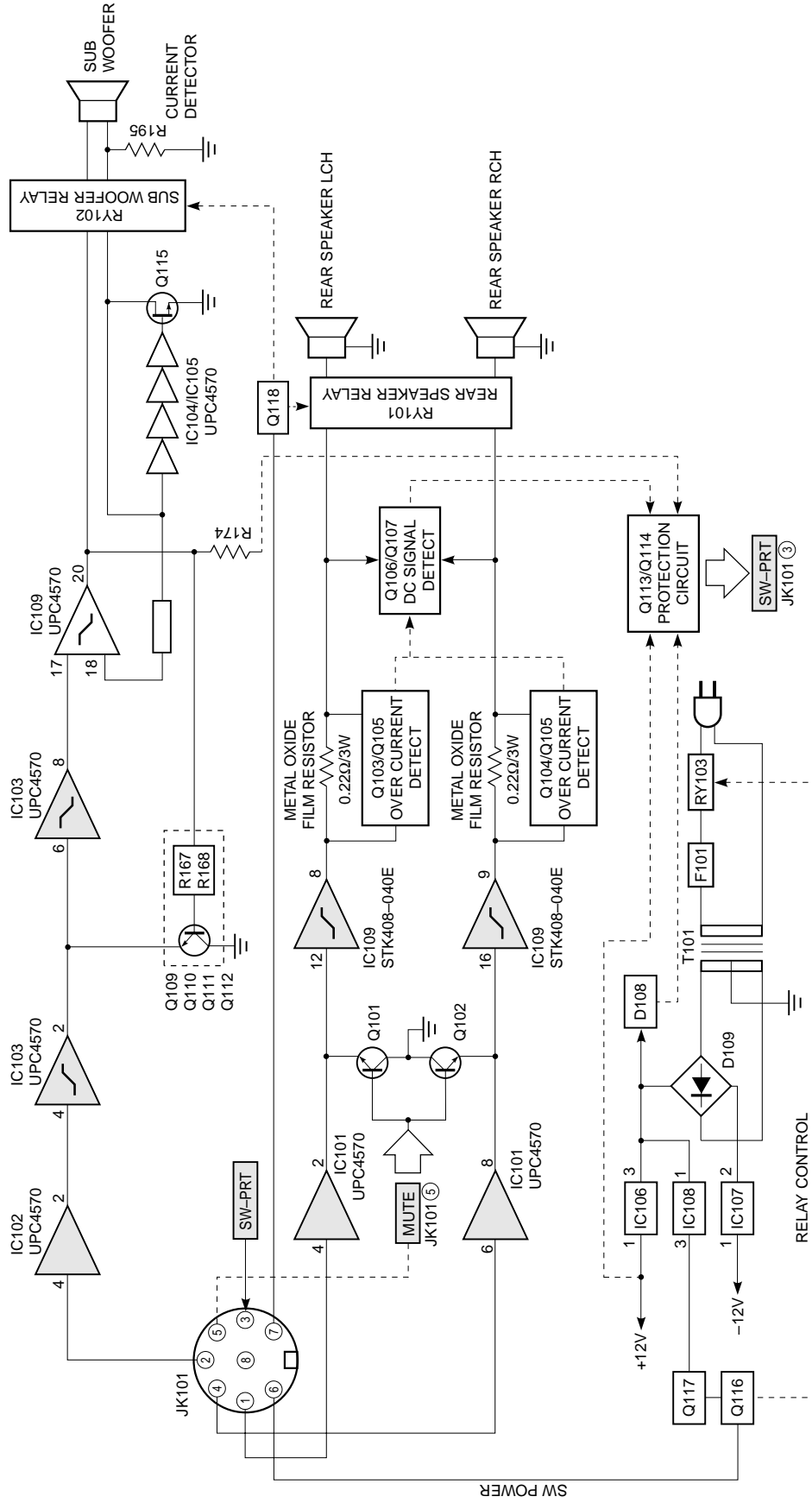

Supplement: When checking NX-SW70 alone, apply a +10V voltage to Pin 6 and Pin7 of the system connector (JK101) to turn on the power.

AV-S70 PRINTED CIRCUIT BOARD

DSP-FL (B) P. C. B. (Component side)

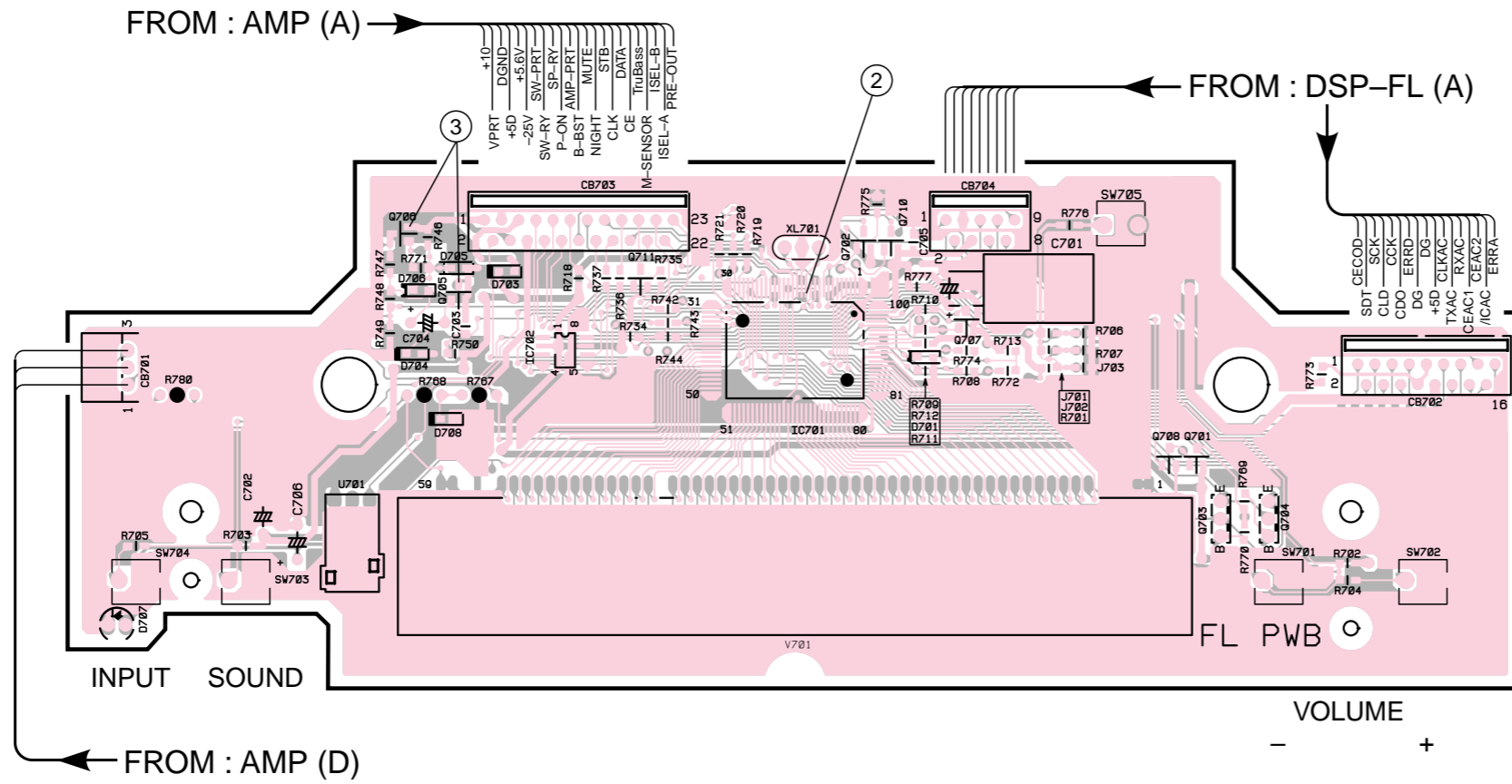

Point ② (Pin 13 of IC701)
 V : 2V/div, H : 0.1 μsec/div
 DC, 1 : 1 probe

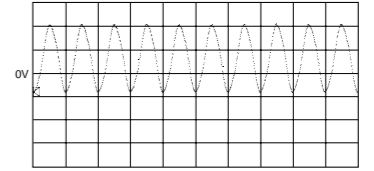

Point ③ (+10V : Emitter of Q706)
 (RESET : Collector of Q705)
 V : 2V/div (+10V), V : 2V/div (RESET)
 DC, 1 : 1 probe, H : 1 sec/div

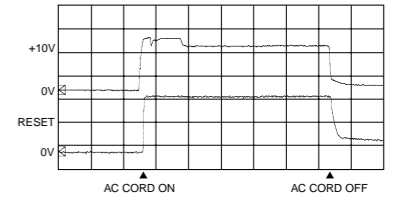

DSP-FL (B) P. C. B. (Foil side)

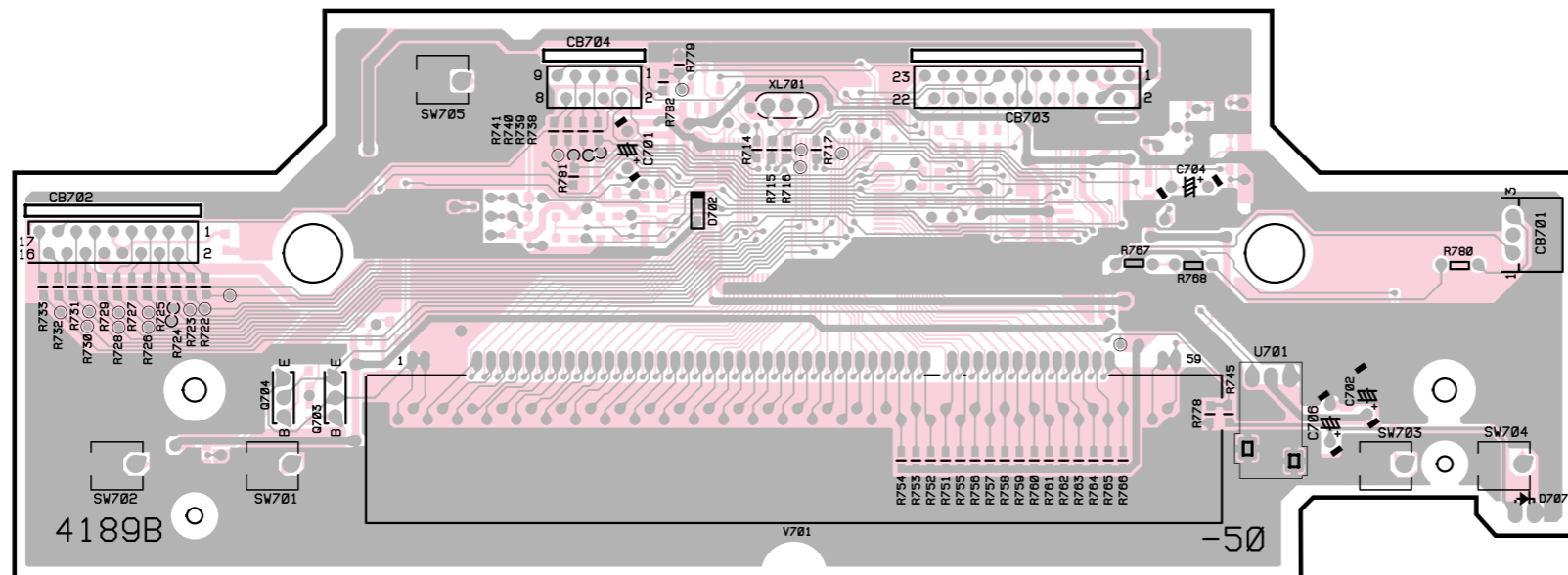

● Semiconductor Location

Ref. No.	Location
D701	D2
D702	D5
D703	C2
D704	C2
D705	C2
D706	C2
D707	B3
D708	C3

Ref. No.	Location
IC801	D2
IC802	C2

Ref. No.	Location
Q701	E3
Q702	D2
Q703	E3
Q704	E3
Q705	C2
Q706	C2
Q707	E3
Q708	E3
Q710	D2
Q711	D2

AV-S70 PRINTED CIRCUIT BOARD

AMP (B) P. C. B. (Component side)

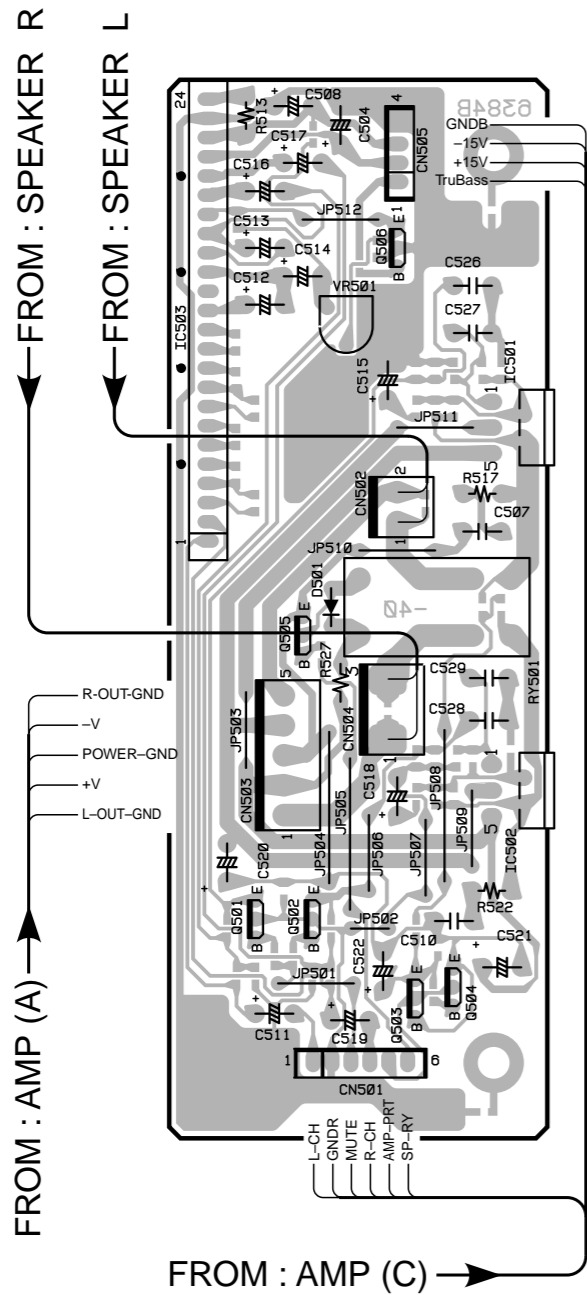

● Semiconductor Location

Ref. No.	Location	Ref. No.	Location	Ref. No.	Location
D501	B3	IC501	B2	Q501	A4
		IC502	B3	Q502	B4
		IC503	A2	Q503	B4
				Q504	B4
				Q505	B3
				Q506	B2

AMP (B) P. C. B. (Foil side)

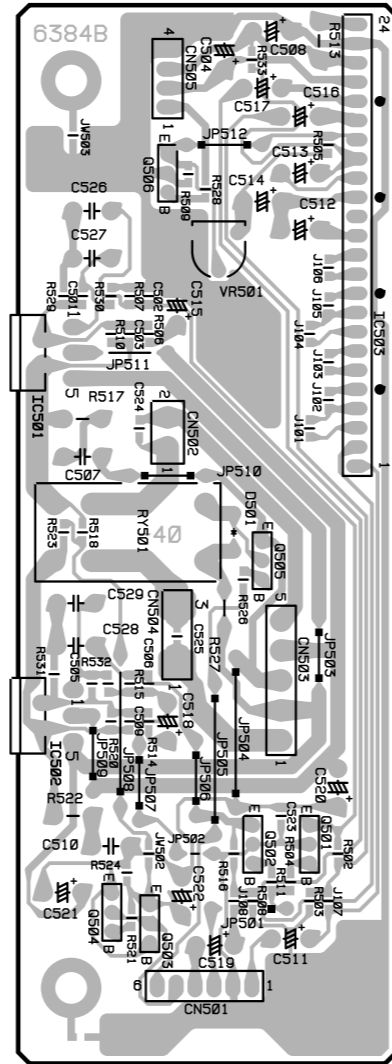

AMP (C) P. C. B. (Component side)

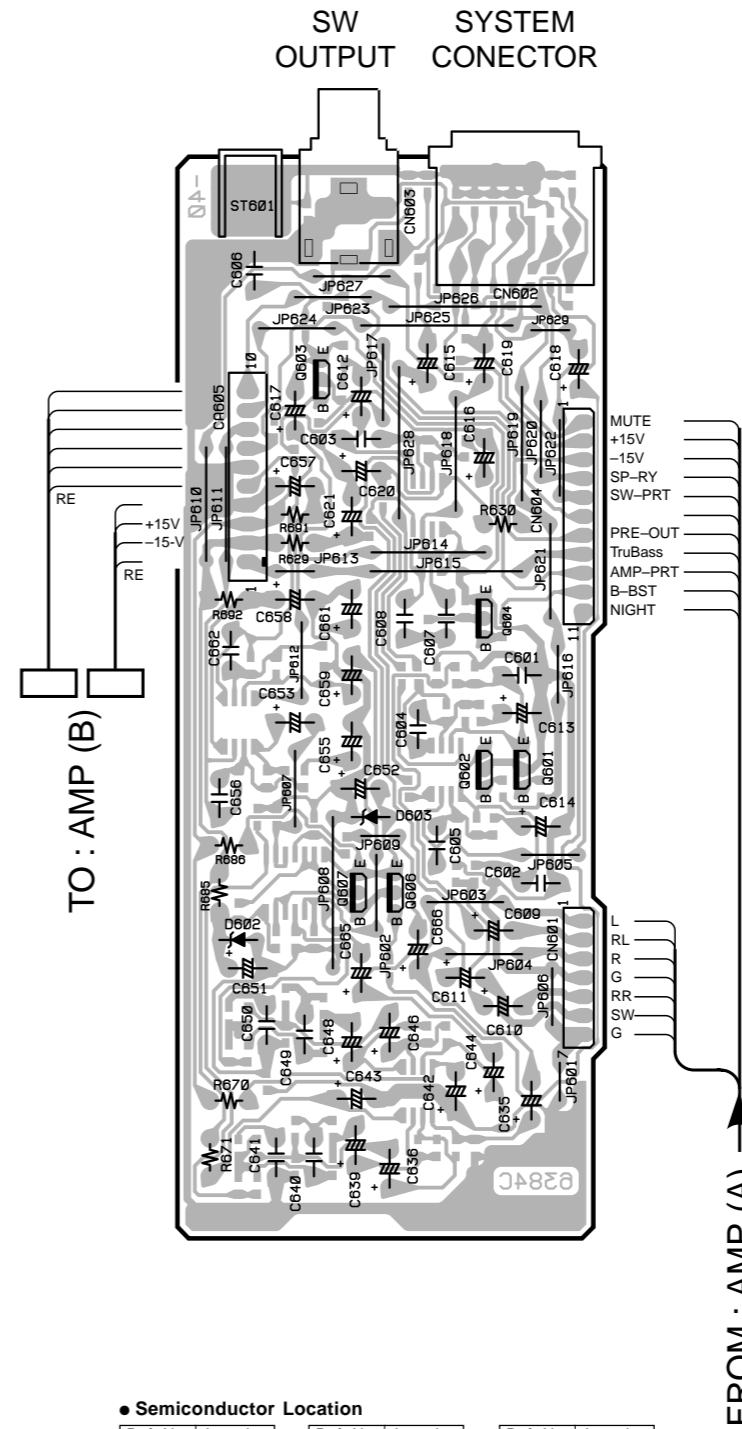

● Semiconductor Location

Ref. No.	Location	Ref. No.	Location	Ref. No.	Location
D602	E4	IC601	G3	Q601	F3
D603	E3	IC602	G3	Q602	F3
		IC603	G4	Q603	E2
		IC604	G4	Q604	F3
		IC605	G3	Q606	E4
				Q607	E4

AMP (C) P. C. B. (Foil side)

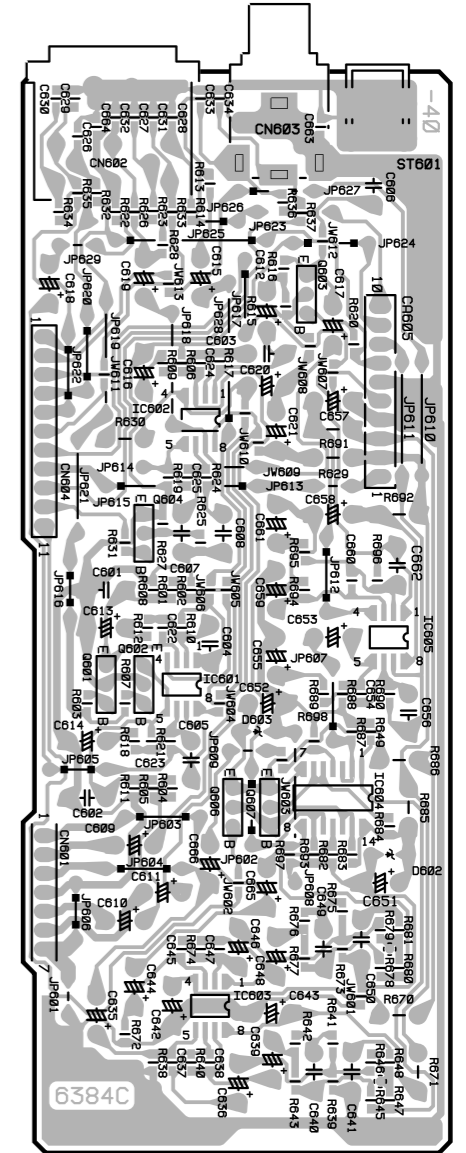

AV-S70 PRINTED CIRCUIT BOARD

AMP (A) P. C. B. (Component side)

AMP (E) P. C. B. (Component side)

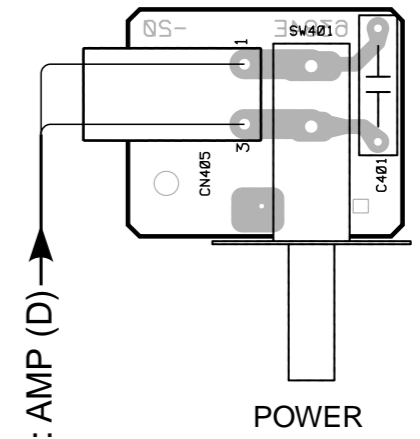
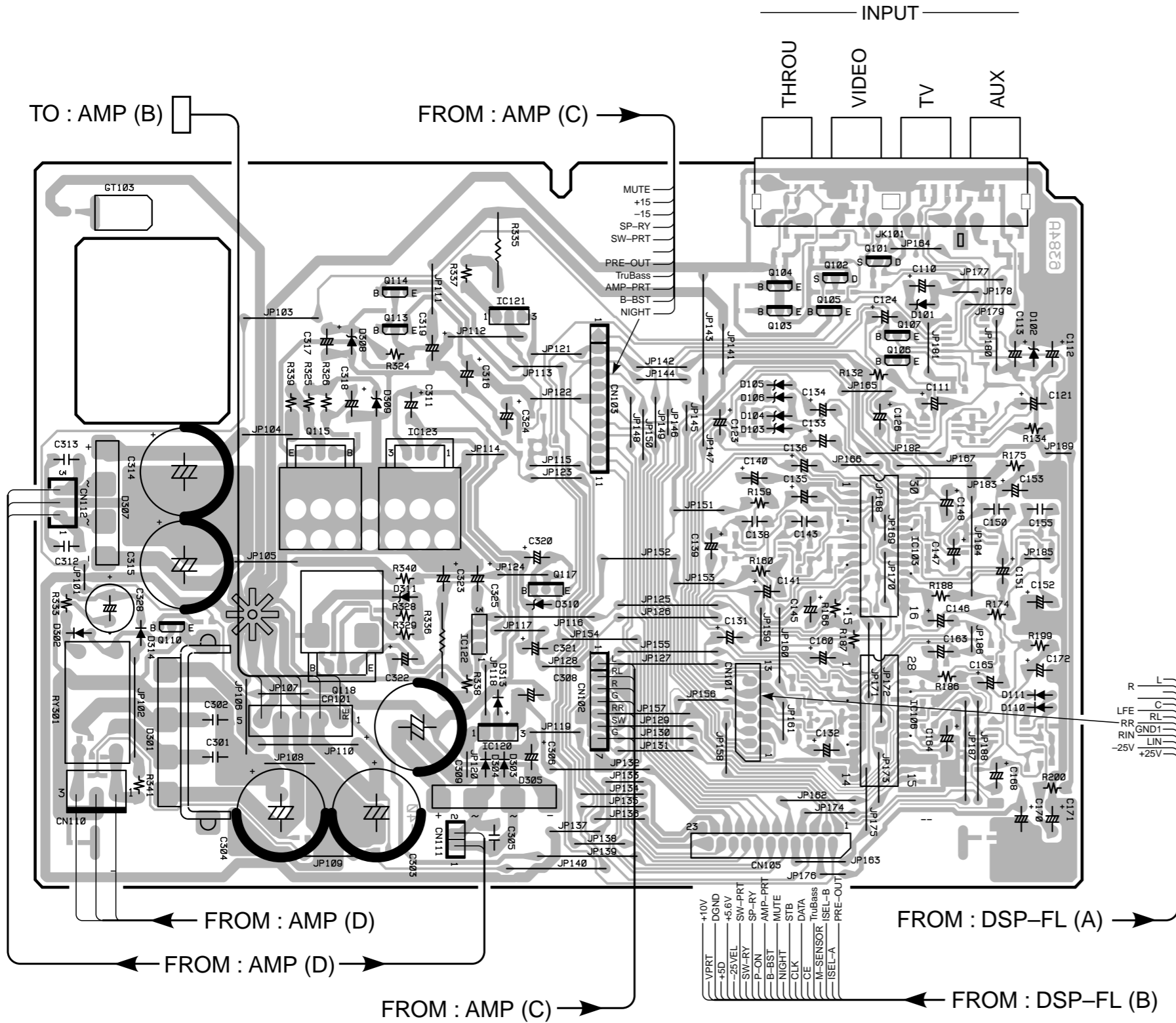

● Semiconductor Location

Ref. No.	Location	Ref. No.	Location	Ref. No.	Location
D101	E3	IC103	D4	Q101	D3
D102	E3	IC106	D4	Q102	D3
D103	D3	IC121	C3	Q103	D3
D104	D3	IC122	C4	Q104	D3
D105	D3	IC123	C3	Q105	D3
D106	D3			Q106	E3
D110	E4			Q107	E3
D111	E4			Q110	B4
D301	B4			Q113	C3
D302	A4			Q114	C3
D303	C5			Q115	B3
D304	C5			Q117	C4
D305	C5			Q118	B4
D307	A4				
D308	B3				
D309	B3				
D310	C4				
D311	B4				
D313	C4				
D314	A4				

SW-AVS70 PRINTED CIRCUIT BOARD

AMP (A) P. C. B. (Component side)

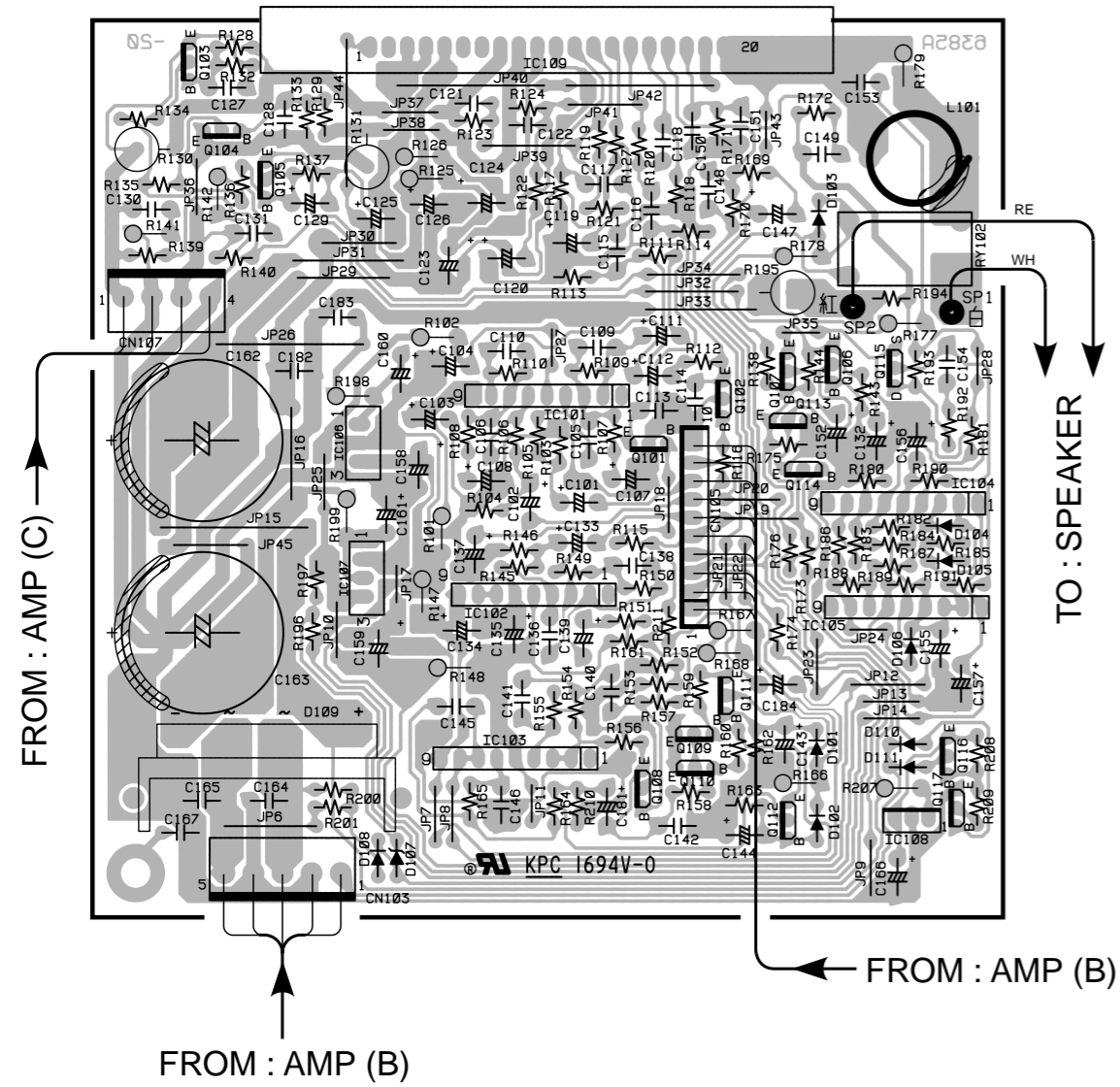

● Semiconductor Location

Ref. No.	Location	Ref. No.	Location	Ref. No.	Location
D101	C3	IC101	B2	Q101	C3
D102	C4	IC102	B3	Q102	C2
D103	C2	IC103	B3	Q103	A1
D104	C3	IC104	C3	Q104	A2
D105	C3	IC105	C3	Q105	A2
D106	C3	IC106	B3	Q106	C2
D107	B4	IC107	B3	Q107	C2
D108	B4	IC108	C4	Q108	C3
D109	A3	IC109	B1	Q109	C3
D110	C3			Q110	C3
D111	C3			Q111	C3
D112	F4			Q112	C4
D113	F2			Q113	C2
				Q114	C3
				Q115	C2
				Q116	C3
				Q117	C4
				Q118	E2

AMP (B) P. C. B. (Component side)

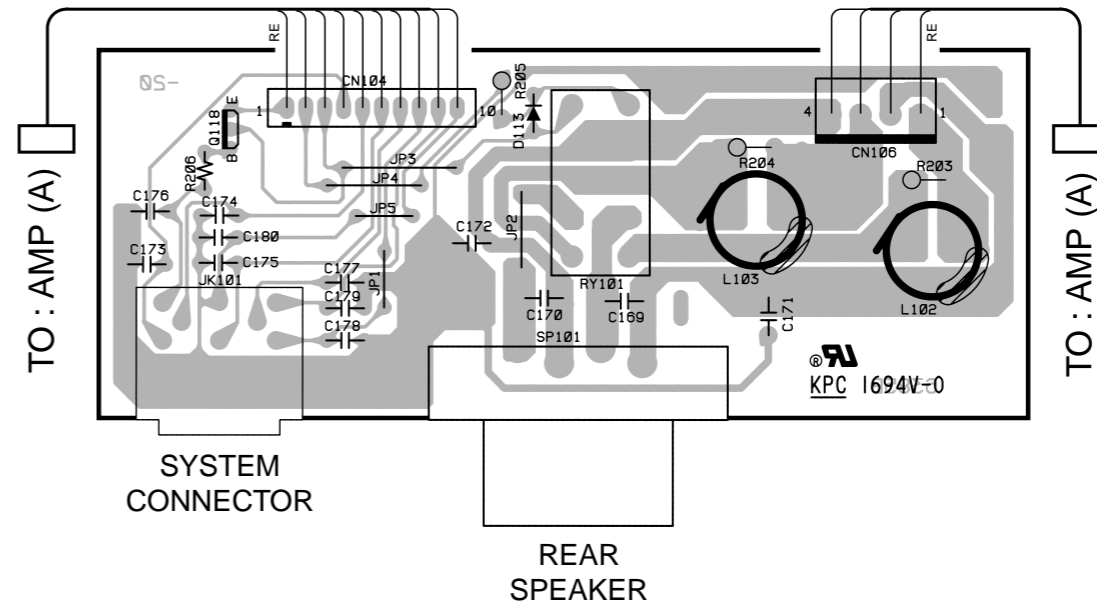

AMP (C) P. C. B. (Component side)

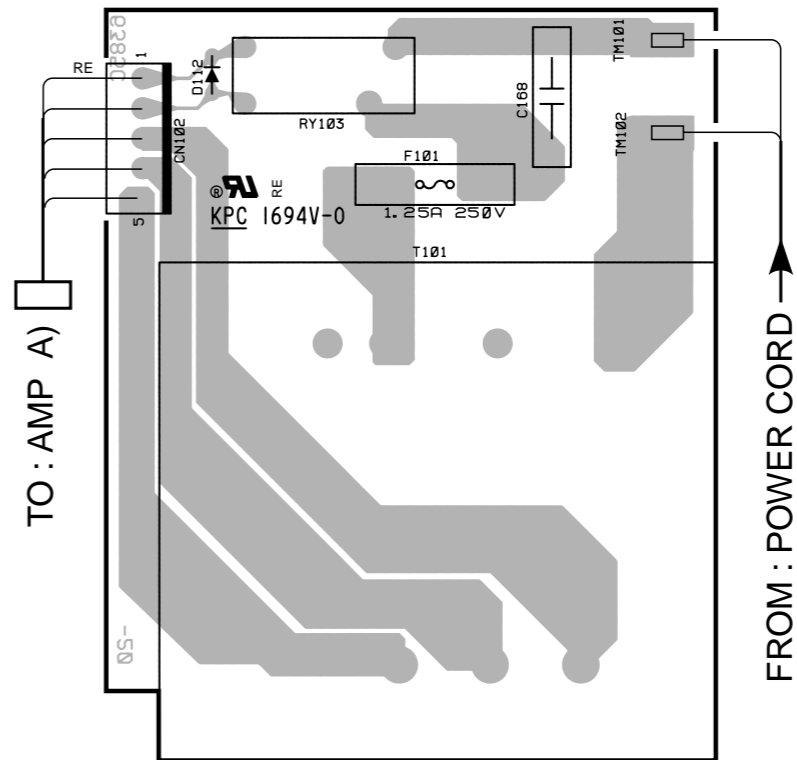

AV-S70 SCHEMATIC DIAGRAM (1/4)

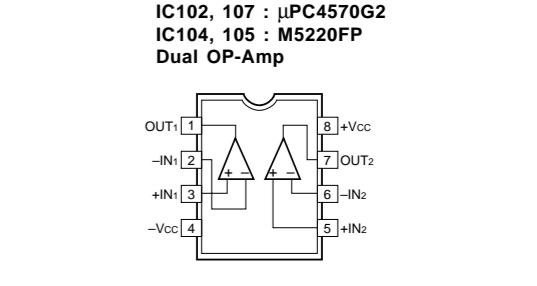
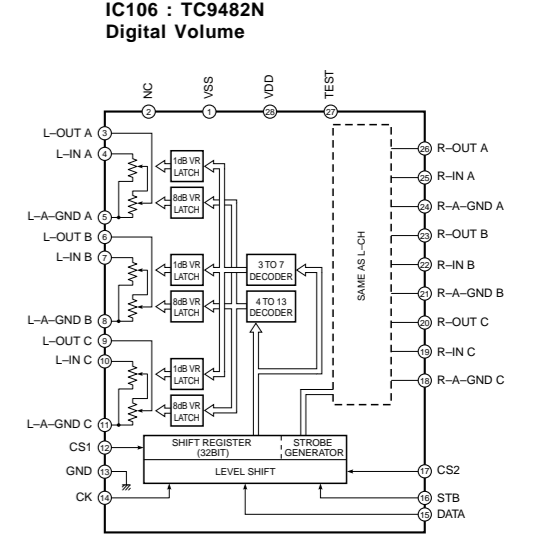
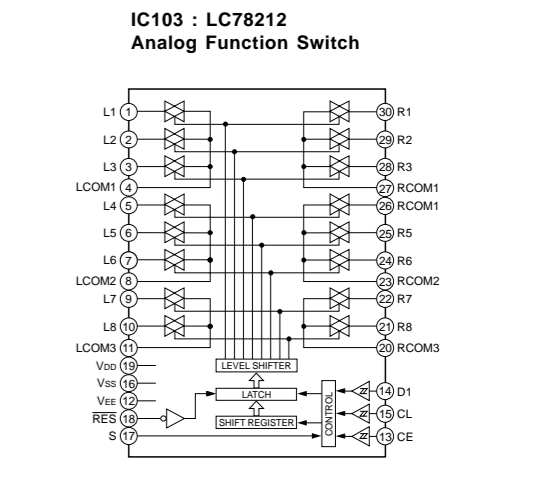
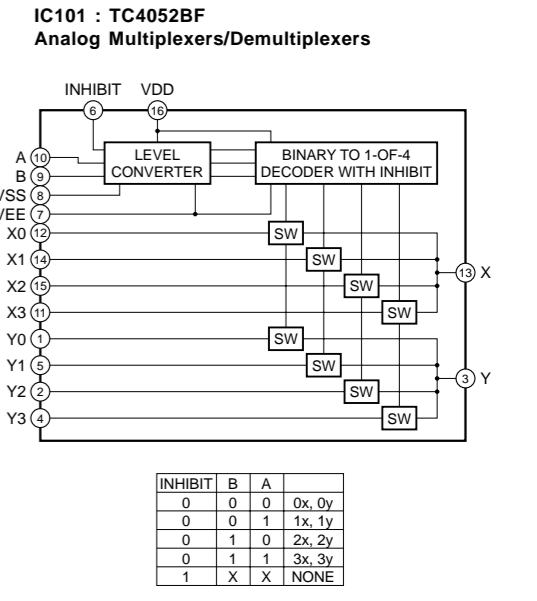
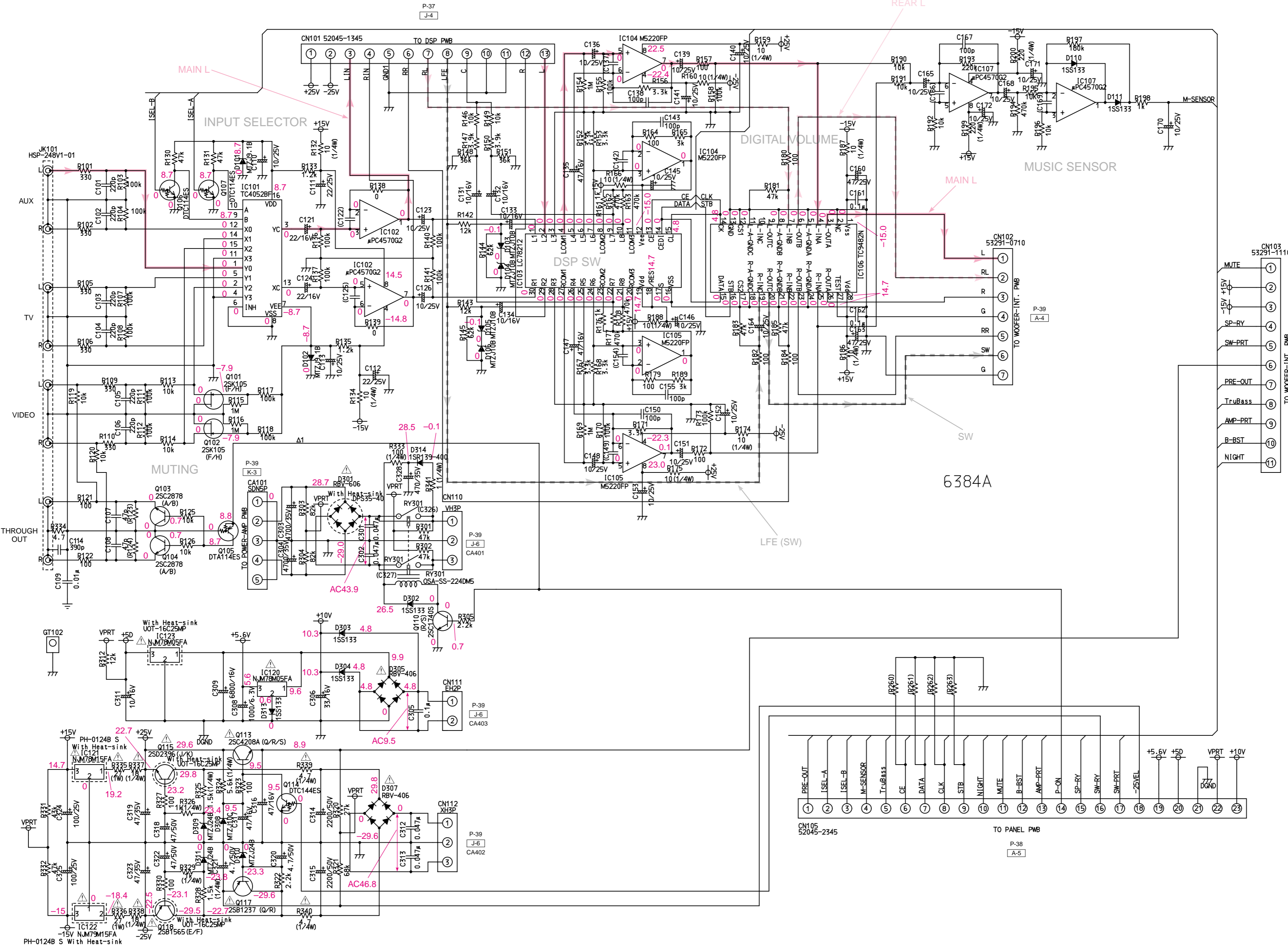

PIN CONNECTION DIAGRAM OF TRANSISTORS, DIODES AND ICs.

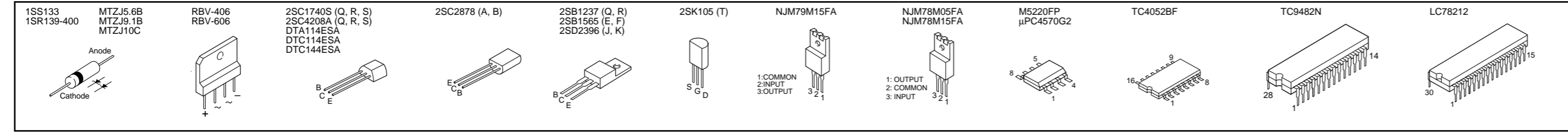

* All voltage are measured with a 10MΩ/V DC electric volt meter.
* Components having special characteristics are marked with a triangle and must be replaced with parts having specifications equal to those originally installed.
* Schematic diagram is subject to change without notice.

AV-S70/NX-SW70
AV-S70 SCHEMATIC DIAGRAM (2/4)

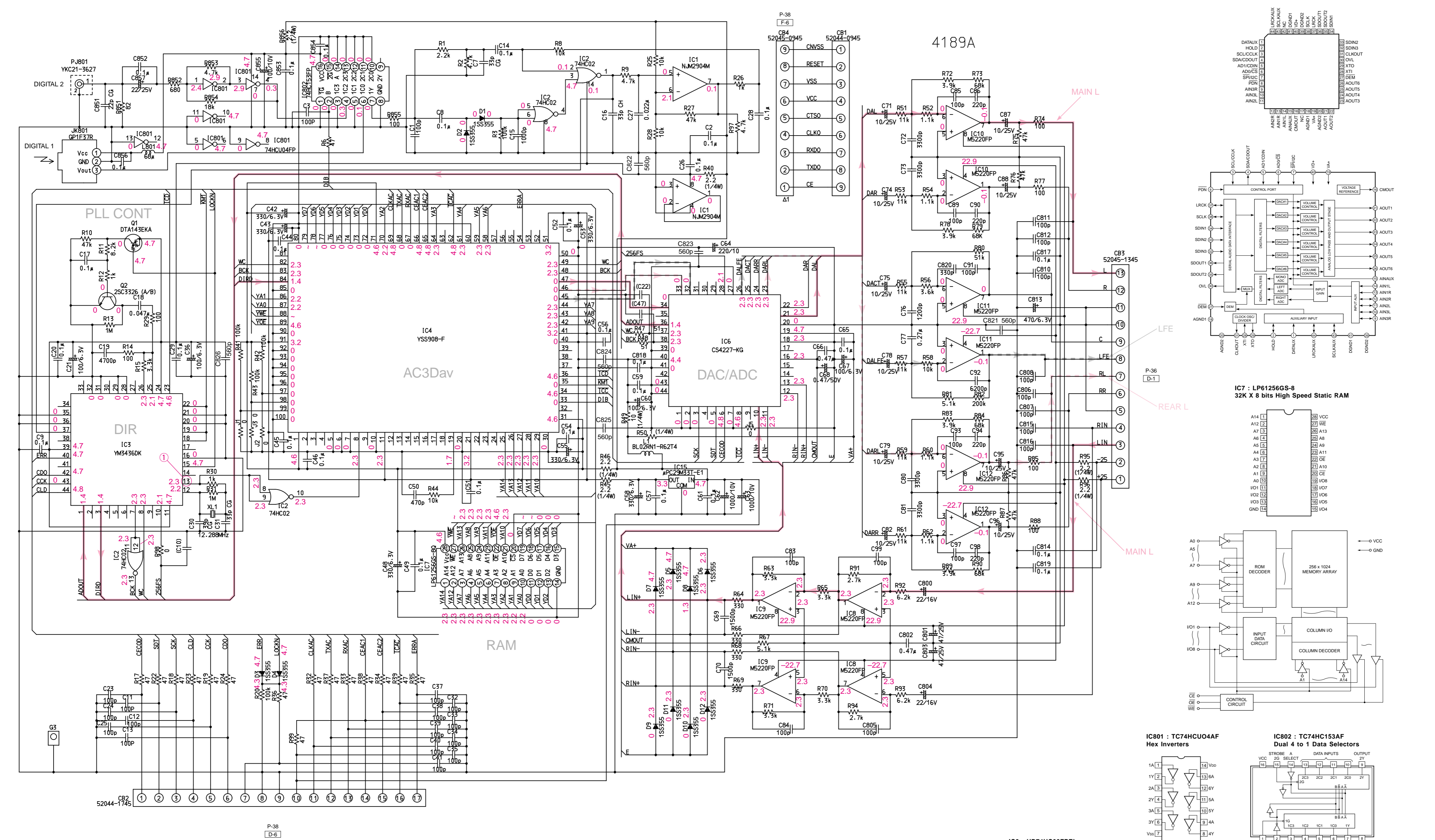

PIN CONNECTION DIAGRAM OF TRANSISTORS, DIODES AND ICs.

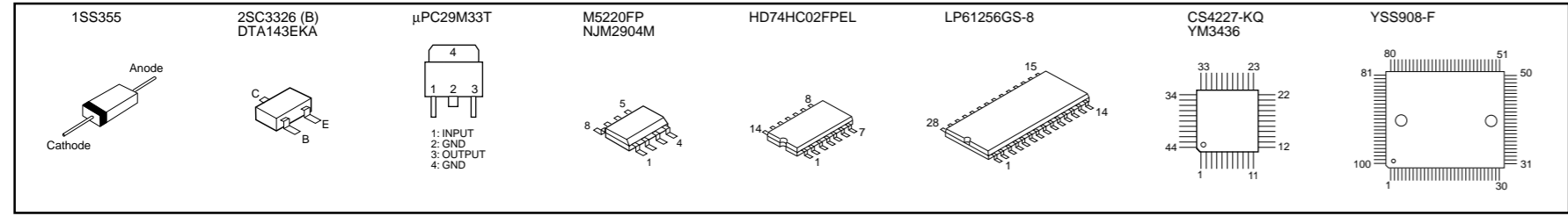

Point ① (Pin 13 of IC3)
 V : 2V/div, H : 0.1 μsec/div
 DC, 1 : 1 probe

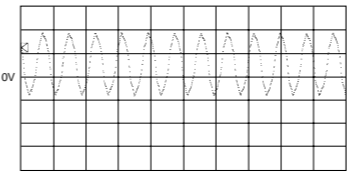

**IC1 : NJM2904M
 IC8-12 : MS220FP
 Dual OP Amp**

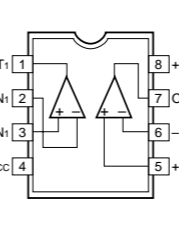

**IC2 : HD74HC02FPPEL
 Quad 2 Input NOR**

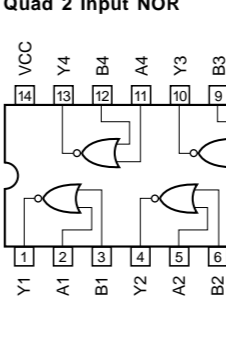

**IC801 : TC74HC04AF
 Hex Inverters**

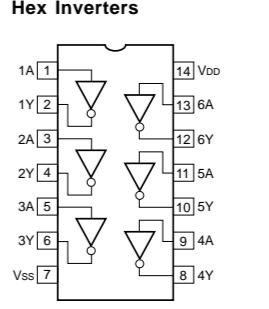

**IC802 : TC74HC153AF
 Dual 4 to 1 Data Selectors**

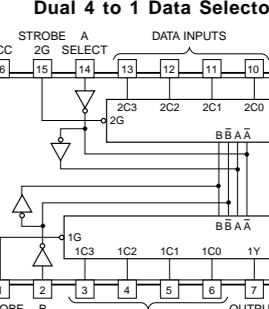

SELECT	STROBE	Y
B A	g	L
X X	H	L
L L	L	G
L L	L	C1
H L	L	C2
H H	L	C3

* All voltage are measured with a 10MΩ/V DC electric volt meter.
 * Components having special characteristics are marked Δ and must be replaced with parts having specifications equal to those originally installed.
 * Schematic diagram is subject to change without notice.

AV-S70 SCHEMATIC DIAGRAM (3/4)

V701 : 13-BT-169GNK (V4879700)

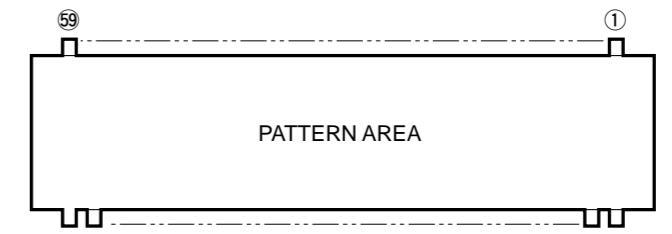
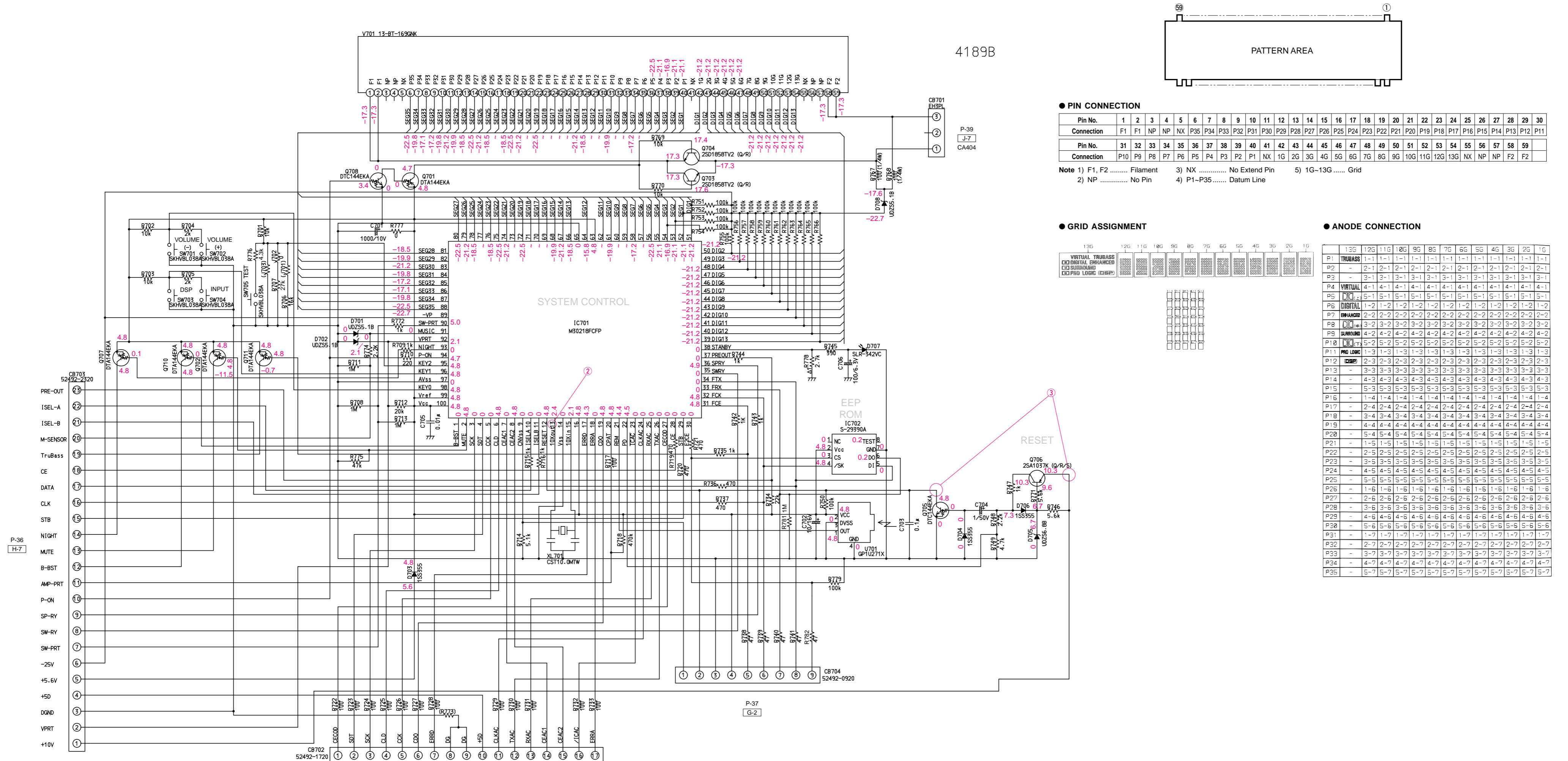

PIN CONNECTION

Pin No.	1	2	3	4	5	6	7	8	9	10	11	12	13	14	15	16	17	18	19	20	21	22	23	24	25	26	27	28	29	30
Connection	F1	F1	NP	NP	NX	P35	P34	P33	P32	P31	P30	P28	P27	P26	P25	P24	P23	P22	P21	P20	P19	P18	P17	P16	P15	P14	P13	P12	P11	
Pin No.	31	32	33	34	35	36	37	38	39	40	41	42	43	44	45	46	47	48	49	50	51	52	53	54	55	56	57	58	59	
Connection	P10	P9	P8	P7	P6	P5	P4	P3	P2	P1	NX	1G	2G	3G	4G	5G	6G	7G	8G	9G	10G	11G	12G	13G	NX	NP	NP	F2	F2	

Note 1) F1, F2 Filament 2) NP No Pin 3) NX No Extend Pin 4) P1-P35 Datum Line
 5) 1G-13G Grid

GRID ASSIGNMENT

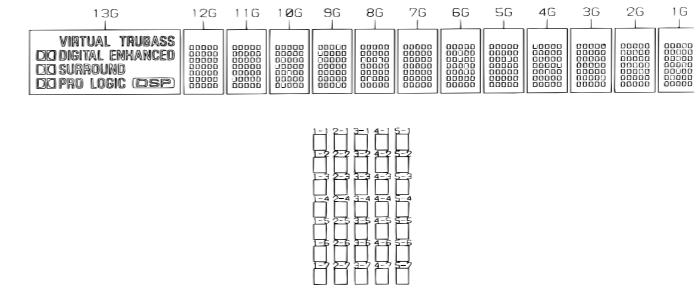

ANODE CONNECTION

P	1G	2G	3G	4G	5G	6G	7G	8G	9G	10G	11G	12G	13G
P1	VIRTUAL TRUBASS	1-1	1-1	1-1	1-1	1-1	1-1	1-1	1-1	1-1	1-1	1-1	1-1
P2	TRUBASS	2-1	2-1	2-1	2-1	2-1	2-1	2-1	2-1	2-1	2-1	2-1	2-1
P3	DIGITAL	3-1	3-1	3-1	3-1	3-1	3-1	3-1	3-1	3-1	3-1	3-1	3-1
P4	VIRTUAL	4-1	4-1	4-1	4-1	4-1	4-1	4-1	4-1	4-1	4-1	4-1	4-1
P5	DIGITAL	5-1	5-1	5-1	5-1	5-1	5-1	5-1	5-1	5-1	5-1	5-1	5-1
P6	DIGITAL	6-1	6-1	6-1	6-1	6-1	6-1	6-1	6-1	6-1	6-1	6-1	6-1
P7	ENHANCED	7-2	7-2	7-2	7-2	7-2	7-2	7-2	7-2	7-2	7-2	7-2	7-2
P8	DIGITAL	8-2	8-2	8-2	8-2	8-2	8-2	8-2	8-2	8-2	8-2	8-2	8-2
P9	SURROUND	9-2	9-2	9-2	9-2	9-2	9-2	9-2	9-2	9-2	9-2	9-2	9-2
P10	DIGITAL	10-2	10-2	10-2	10-2	10-2	10-2	10-2	10-2	10-2	10-2	10-2	10-2
P11	PRO LOGIC	11-3	11-3	11-3	11-3	11-3	11-3	11-3	11-3	11-3	11-3	11-3	11-3
P12	TRUBASS	12-3	12-3	12-3	12-3	12-3	12-3	12-3	12-3	12-3	12-3	12-3	12-3
P13	DIGITAL	13-3	13-3	13-3	13-3	13-3	13-3	13-3	13-3	13-3	13-3	13-3	13-3
P14	DIGITAL	4-3	4-3	4-3	4-3	4-3	4-3	4-3	4-3	4-3	4-3	4-3	4-3
P15	DIGITAL	5-3	5-3	5-3	5-3	5-3	5-3	5-3	5-3	5-3	5-3	5-3	5-3
P16	DIGITAL	6-4	6-4	6-4	6-4	6-4	6-4	6-4	6-4	6-4	6-4	6-4	6-4
P17	DIGITAL	7-4	7-4	7-4	7-4	7-4	7-4	7-4	7-4	7-4	7-4	7-4	7-4
P18	DIGITAL	8-4	8-4	8-4	8-4	8-4	8-4	8-4	8-4	8-4	8-4	8-4	8-4
P19	DIGITAL	9-4	9-4	9-4	9-4	9-4	9-4	9-4	9-4	9-4	9-4	9-4	9-4
P20	DIGITAL	10-4	10-4	10-4	10-4	10-4	10-4	10-4	10-4	10-4	10-4	10-4	10-4
P21	DIGITAL	11-5	11-5	11-5	11-5	11-5	11-5	11-5	11-5	11-5	11-5	11-5	11-5
P22	DIGITAL	2-5	2-5	2-5	2-5	2-5	2-5	2-5	2-5	2-5	2-5	2-5	2-5
P23	DIGITAL	3-5	3-5	3-5	3-5	3-5	3-5	3-5	3-5	3-5	3-5	3-5	3-5
P24	DIGITAL	4-5	4-5	4-5	4-5	4-5	4-5	4-5	4-5	4-5	4-5	4-5	4-5
P25	DIGITAL	5-5	5-5	5-5	5-5	5-5	5-5	5-5	5-5	5-5	5-5	5-5	5-5
P26	DIGITAL	6-6	6-6	6-6	6-6	6-6	6-6	6-6	6-6	6-6	6-6	6-6	6-6
P27	DIGITAL	7-6	7-6	7-6	7-6	7-6	7-6	7-6	7-6	7-6	7-6	7-6	7-6
P28	DIGITAL	8-6	8-6	8-6	8-6	8-6	8-6	8-6	8-6	8-6	8-6	8-6	8-6
P29	DIGITAL	9-6	9-6	9-6	9-6	9-6	9-6	9-6	9-6	9-6	9-6	9-6	9-6
P30	DIGITAL	10-6	10-6	10-6	10-6	10-6	10-6	10-6	10-6	10-6	10-6	10-6	10-6
P31	DIGITAL	11-7	11-7	11-7	11-7	11-7	11-7	11-7	11-7	11-7	11-7	11-7	11-7
P32	DIGITAL	2-7	2-7	2-7	2-7	2-7	2-7	2-7	2-7	2-7	2-7	2-7	2-7
P33	DIGITAL	3-7	3-7	3-7	3-7	3-7	3-7	3-7	3-7	3-7	3-7	3-7	3-7
P34	DIGITAL	4-7	4-7	4-7	4-7	4-7	4-7	4-7	4-7	4-7	4-7	4-7	4-7
P35	DIGITAL	5-7	5-7	5-7	5-7	5-7	5-7	5-7	5-7	5-7	5-7	5-7	5-7

PIN CONNECTION DIAGRAM OF TRANSISTORS, DIODES AND ICs.

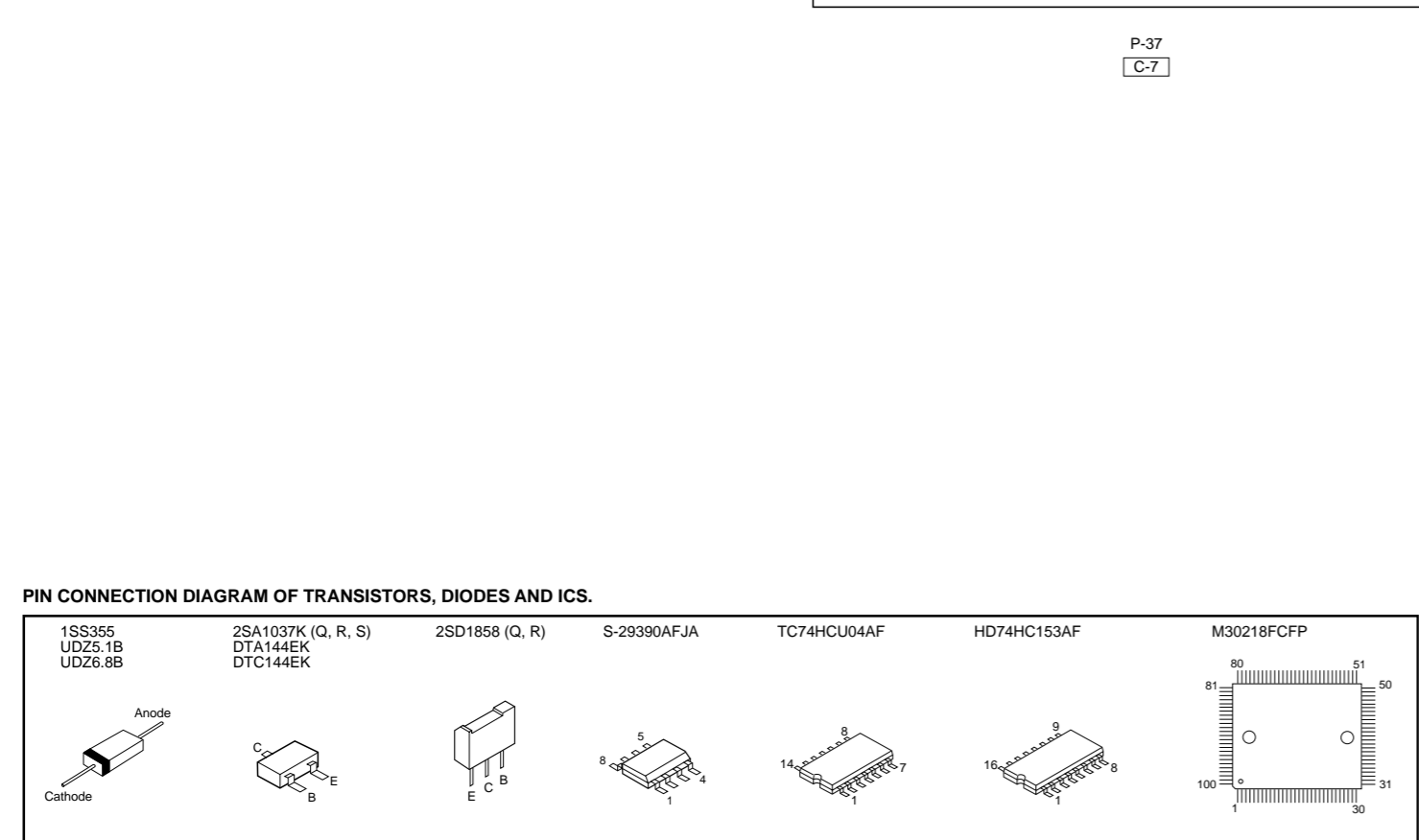

Point ② (Pin 13 of IC701)
 V : 2V/div, H : 0.1 μsec/div
 DC, 1 : 1 probe

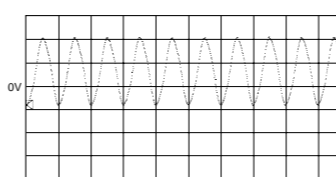

Point ③ (+10V : Emitter of Q706)
 (RESET : Collector of Q705)
 V : 2V/div (+10V), V : 2V/div (RESET)
 DC, 1 : 1 probe

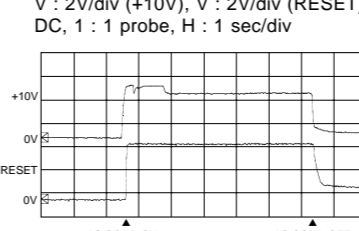

* All voltage are measured with a 10MΩ/V DC electric volt meter.
 * Components having special characteristics are marked Δ and must be replaced with parts having specifications equal to those originally installed.
 * Schematic diagram is subject to change without notice.

AV-S70 SCHEMATIC DIAGRAM (4/4)

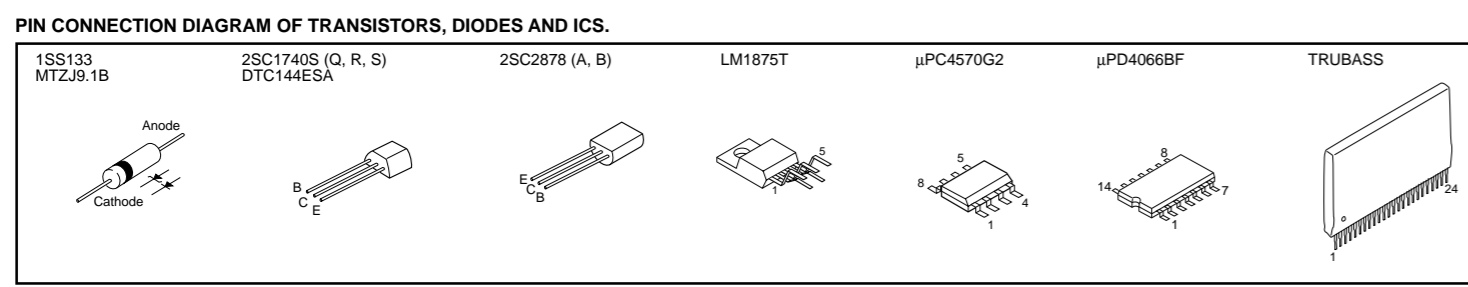
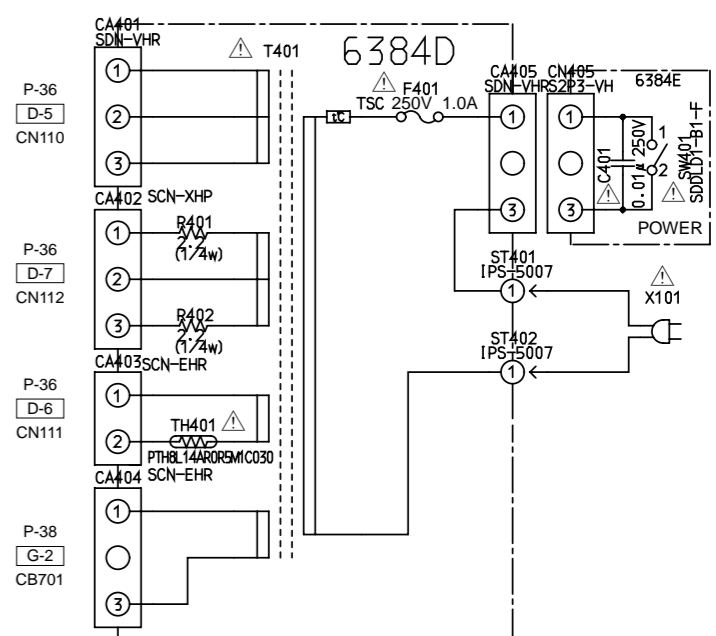
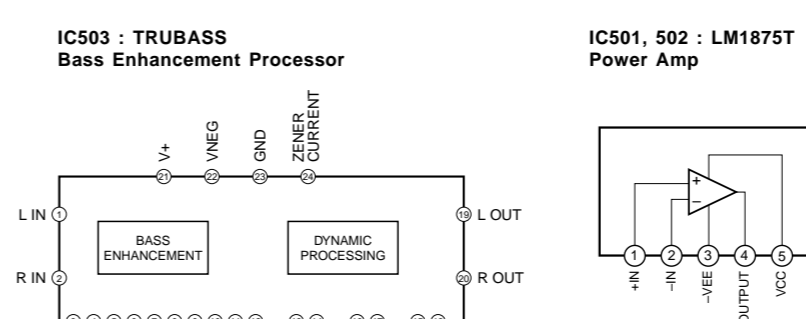
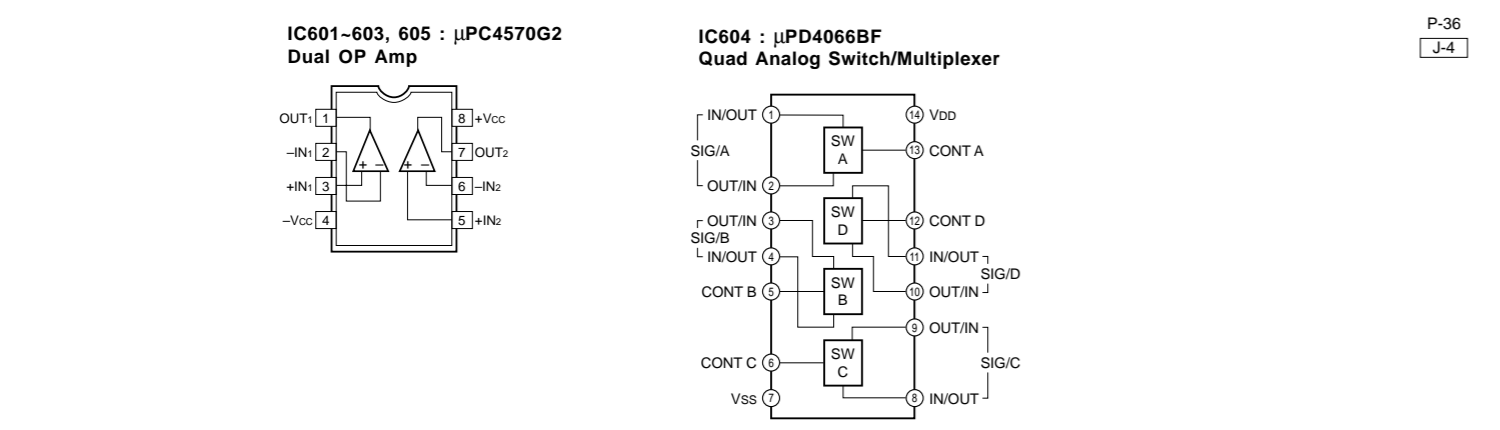
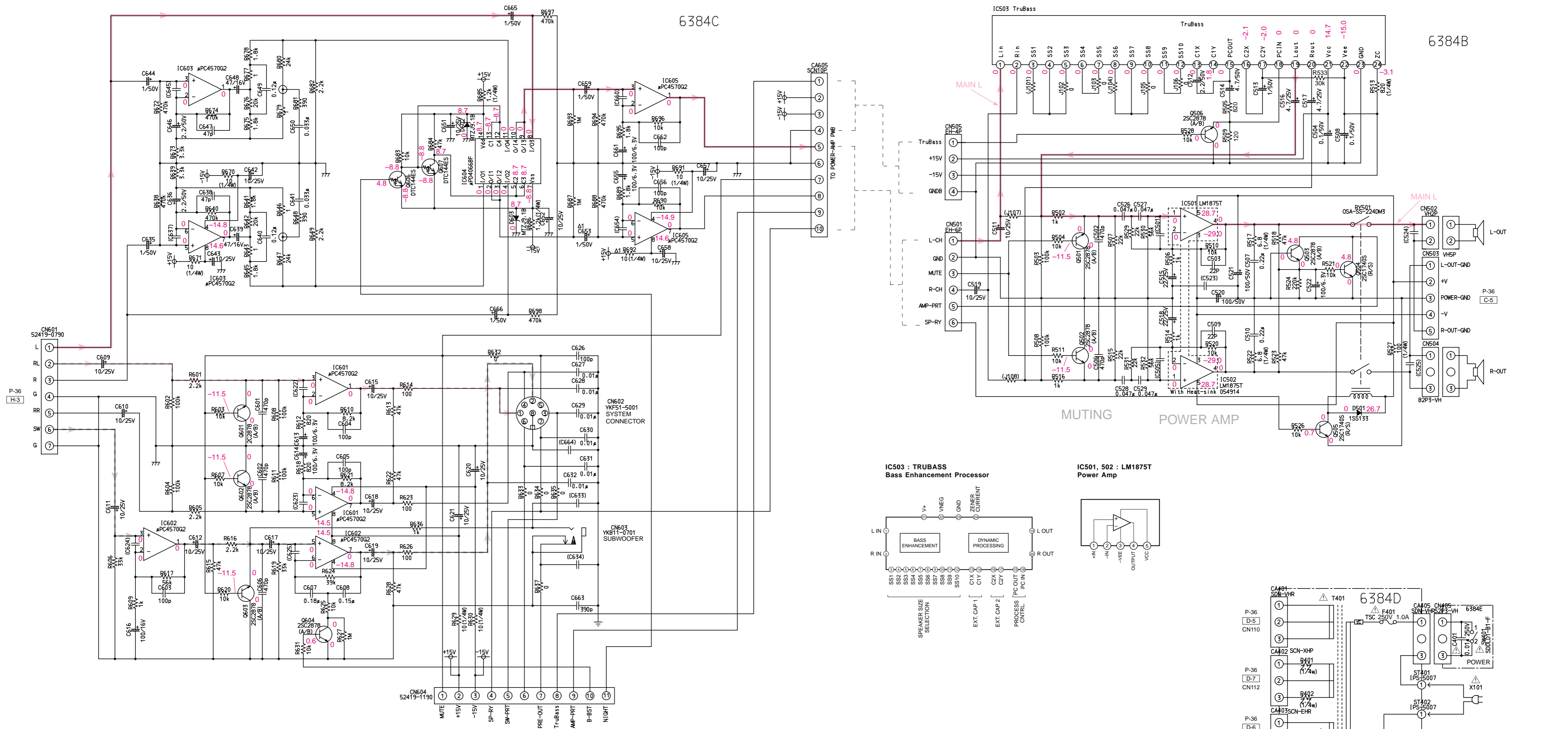

* All voltage are measured with a 10M Ω /V DC electric volt meter.
 * Components having special characteristics are marked Δ and must be replaced with parts having specifications equal to those originally installed.
 * Schematic diagram is subject to change without notice.

SW-AVS70 SCHEMATIC DIAGRAM

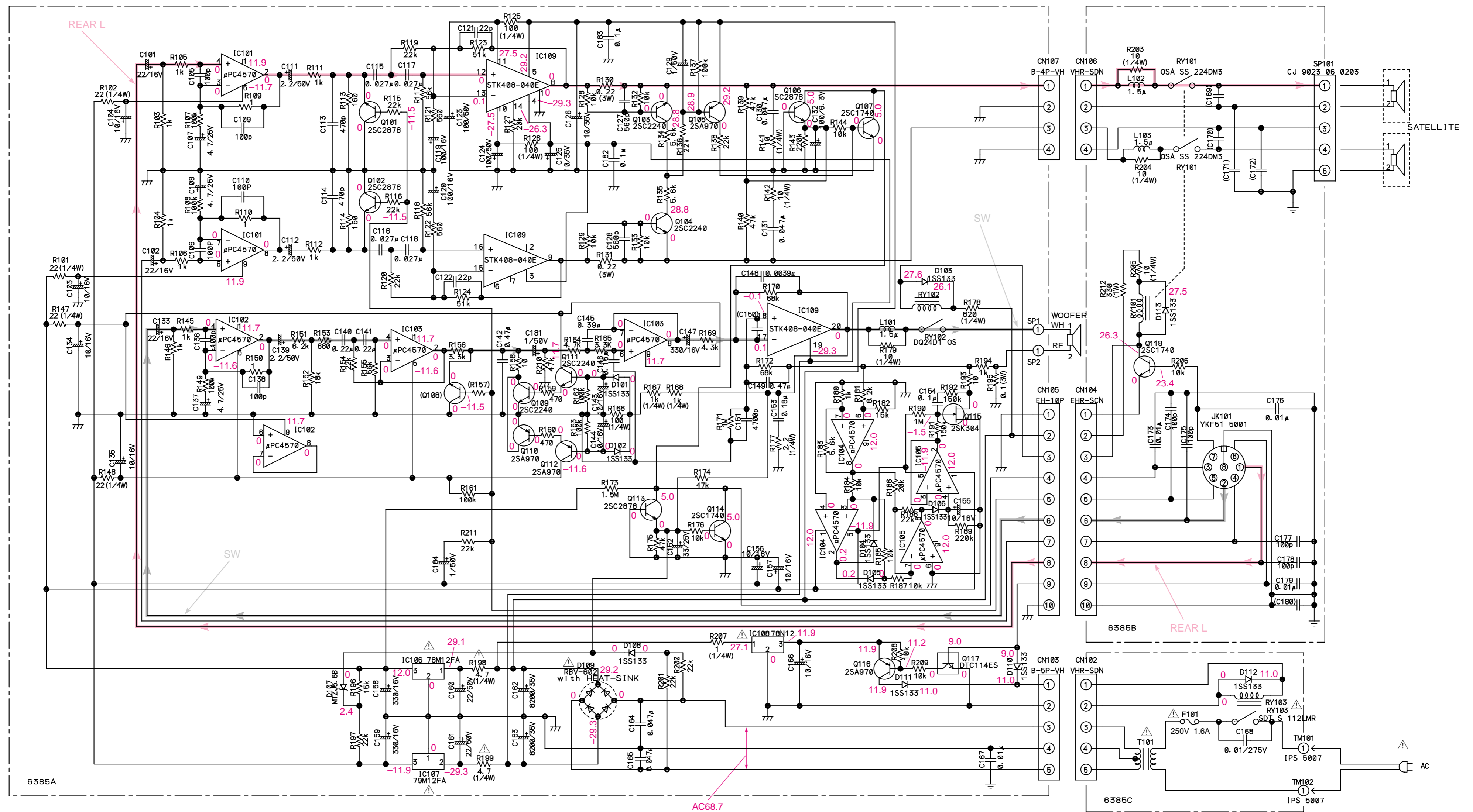

PIN CONNECTION DIAGRAM OF TRANSISTORS, DIODES AND ICs.

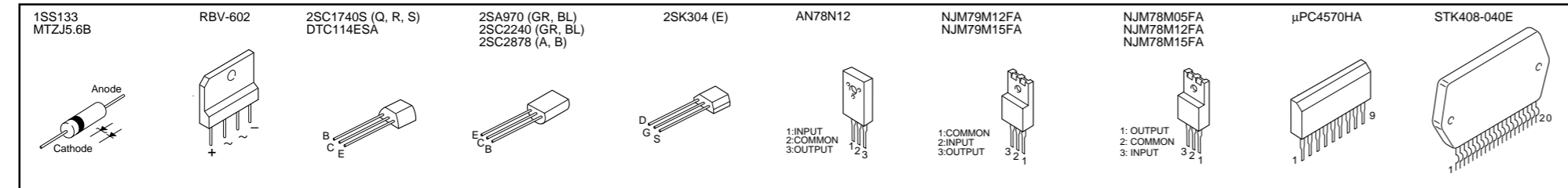

IC101-105 : μPC4570HA Dual OP-Amp

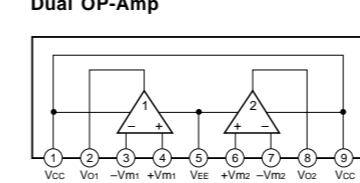

IC109 : STK408-040E 3 Channel AF Power Amp

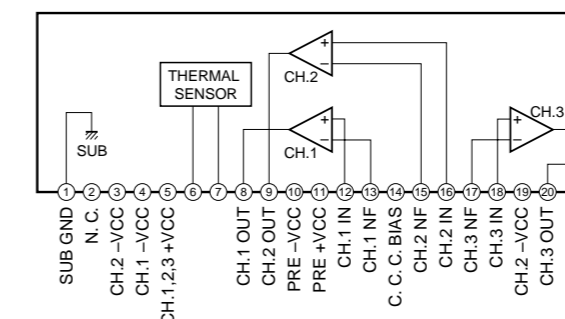

* All voltage are measured with a 10MΩ/V DC electric volt meter.
 * Components having special characteristics are marked Δ and must be replaced with parts having specifications equal to those originally installed.
 * Schematic diagram is subject to change without notice.

PARTS LIST

■ ELECTRICAL PARTS

■ WARNING

Components having special characteristics are marked \triangle and must be replaced with parts having specifications equal to those originally installed.

- Carbon resistors (1/6W or 1/4W) are not included in the ELECTRICAL PARTS List. For the parts No. of the carbon resistors, refer to last page.

ABBREVIATIONS IN THIS LIST ARE AS FOLLOWS :

C.A.EL.CHP	: CHIP ALUMI. ELECTROLYTIC CAP	L.EMIT	: LIGHT EMITTING MODULE
C.CE	: CERAMIC CAP	LED.DSPLY	: LED DISPLAY
C.CE.ARRAY	: CERAMIC CAP ARRAY	LED.INFRD	: LED, INFRARED
C.CE.CHP	: CHIP CERAMIC CAP	MODUL.RF	: MODULATOR, RF
C.CE.ML	: MULTILAYER CERAMIC CAP	PHOT.CPL	: PHOTO COUPLER
C.CE.M.CHP	: CHIP MULTILAYER CERAMIC CAP	PHOT.INTR	: PHOTO INTERRUPTER
C.CE.SAFTY	: RECOGNIZED CERAMIC CAP	PHOT.RFLCT	: PHOTO REFLECTOR
C.CE.TUBLR	: CERAMIC TUBULAR CAP	PIN.TEST	: PIN, TEST POINT
C.CE.SMI	: SEMI CONDUCTIVE CERAMIC CAP	PLST.RIVET	: PLASTIC RIVET
C.EL	: ELECTROLYTIC CAP	R.ARRAY	: RESISTOR ARRAY
C.MICA	: MICA CAP	R.CAR	: CARBON RESISTOR
C.ML.FLM	: MULTILAYER FILM CAP	R.CAR.CHP	: CHIP RESISTOR
C.MP	: METALLIZED PAPER CAP	R.CAR.FP	: FLAME PROOF CARBON RESISTOR
C.MYLAR	: MYLAR FILM CAP	R.FUS	: FUSABLE RESISTOR
C.MYLAR.ML	: MULTILAYER MYLAR FILM CAP	R.MTL.CHP	: CHIP METAL FILM RESISTOR
C.PAPER	: PAPER CAPACITOR	R.MTL.FLM	: METAL FILM RESISTOR
C.PLS	: POLYSTYRENE FILM CAP	R.MTL.OXD	: METAL OXIDE FILM RESISTOR
C.POL	: POLYESTER FILM CAP	R.MTL.PLAT	: METAL PLATE RESISTOR
C.POLY	: POLYETHYLENE FILM CAP	RSNR.CE	: CERAMIC RESONATOR
C.PP	: POLYPROPYLENE FILM CAP	RSNR.CRYS	: CRYSTAL RESONATOR
C.TNTL	: TANTALUM CAP	R.TW.CEM	: TWIN CEMENT FIXED RESISTOR
C.TNTL.CHP	: CHIP TANTALUM CAP	R.WW	: WIRE WOUND RESISTOR
C.TRIM	: TRIMMER CAP	SCR.BND.HD	: BIND HEAD B-TITE SCREW
CN	: CONNECTOR	SCR.BW.HD	: BW HEAD TAPPING SCREW
CN.BS.PIN	: CONNECTOR, BASE PIN	SCR.CUP	: CUP TITE SCREW
CN.CANNON	: CONNECTOR, CANNON	SCR.TERM	: SCREW TERMINAL
CN.DIN	: CONNECTOR, DIN	SCR.TR	: SCREW, TRANSISTOR
CN.FLAT	: CONNECTOR, FLAT CABLE	SUPRT.PCB	: SUPPORT, P.C.B.
CN.POST	: CONNECTOR, BASE POST	SURG.PRTCT	: SURGE PROTECTOR
COIL.MX.AM	: COIL, AM MIX	SW.TACT	: TACT SWITCH
COIL.AT.FM	: COIL, FM ANTENNA	SW.LEAF	: LEAF SWITCH
COIL.DT.FM	: COIL, FM DETECT	SW.LEVER	: LEVER SWITCH
COIL.MX.FM	: COIL, FM MIX	SW.MICRO	: MICRO SWITCH
COIL.OUTPT	: OUTPUT COIL	SW.PUSH	: PUSH SWITCH
DIOD.ARRAY	: DIODE ARRAY	SW.RT.ENC	: ROTARY ENCODER
DIODE.BRG	: DIODE BRIDGE	SW.RT.MTR	: ROTARY SWITCH WITH MOTOR
DIODE.CHP	: CHIP DIODE	SW.RT	: ROTARY SWITCH
DIODE.VAR	: VARACTOR DIODE	SW.SLIDE	: SLIDE SWITCH
DIOD.Z.CHP	: CHIP ZENER DIODE	TERM.SP	: SPEAKER TERMINAL
DIODE.ZENR	: ZENER DIODE	TERM.WRAP	: WRAPPING TERMINAL
DSCR.CE	: CERAMIC DISCRIMINATOR	THRMST.CHP	: CHIP THERMISTOR
FER.BEAD	: FERRITE BEADS	TR.CHP	: CHIP TRANSISTOR
FER.CORE	: FERRITE CORE	TR.DGT	: DIGITAL TRANSISTOR
FET.CHP	: CHIP FET	TR.DGT.CHP	: CHIP DIGITAL TRANSISTOR
FL.DSPLY	: FLUORESCENT DISPLAY	TRANS	: TRANSFORMER
FLTR.CE	: CERAMIC FILTER	TRANS.PULS	: PULSE TRANSFORMER
FLTR.COMB	: COMB FILTER MODULE	TRANS.PWR	: POWER TRANSFORMER ASS'y
FLTR.LC.RF	: LC FILTER, EMI	TUNER.AM	: TUNER PACK, AM
GND.MTL	: GROUND PLATE	TUNER.FM	: TUNER PACK, FM
GND.TERM	: GROUND TERMINAL	TUNER.PK	: FRONT-END TUNER PACK
HOLDER.FUS	: FUSE HOLDER	VR	: ROTARY POTENTIOMETER
IC.PRTCT	: IC PROTECTOR	VR.MTR	: POTENTIOMETER WITH MOTOR
JUMPER.CN	: JUMPER CONNECTOR	VR.SW	: POTENTIOMETER WITH ROTARY SW
JUMPER.TST	: JUMPER, TEST POINT	VR.SLIDE	: SLIDE POTENTIOMETER
L.DTCT	: LIGHT DETECTING MODULE	VR.TRIM	: TRIMMER POTENTIOMETER

Note) Those parts marked with “#” are not included in the P.C.B. ass'y.

AV-S70 P.C.B. AMP

Schm Ref.	PART NO.	Description	Remarks
*	AA15150	P.C.B.	AMP 331416
* C101	AA10700	C.CE.CHP	220pF 50V 065619
* C102	AA10700	C.CE.CHP	220pF 50V 065619
* C103	AA10700	C.CE.CHP	220pF 50V 065619
* C104	AA10700	C.CE.CHP	220pF 50V 065619
* C105	AA10700	C.CE.CHP	220pF 50V 065619
* C106	AA10700	C.CE.CHP	220pF 50V 065619
* C107	AA10760	C.CE.CHP	47pF 50V 065881
* C108	AA10760	C.CE.CHP	47pF 50V 065881
C109	XX698630	C.CE.CHP	0.01uF 50V 065610
* C110	AA10160	C.EL	10uF 25V 066286
* C111	AA10270	C.EL	22uF 25V 066347
* C112	AA10270	C.EL	22uF 25V 066347
* C113	AA10160	C.EL	10uF 25V 066286
* C121	AA10260	C.EL	22uF 16V 066345
* C123	AA10160	C.EL	10uF 25V 066286
* C124	AA10260	C.EL	22uF 16V 066345
* C126	AA10160	C.EL	10uF 25V 066286
* C131	AA10150	C.EL	10uF 16V 066282
* C132	AA10150	C.EL	10uF 16V 066282
* C133	AA10150	C.EL	10uF 16V 066282
* C134	AA10150	C.EL	10uF 16V 066282
C135	XX698310	C.EL	47uF 16V 066424
* C136	AA10160	C.EL	10uF 25V 066286
* C138	AA11120	C.POL	10pF 50V 055439
* C139	AA10160	C.EL	10uF 25V 066286
* C140	AA10160	C.EL	10uF 25V 066286
* C141	AA10160	C.EL	10uF 25V 066286
* C143	AA11120	C.POL	10pF 50V 055439
* C145	AA10160	C.EL	10uF 25V 066286
* C146	AA10160	C.EL	10uF 25V 066286
C147	XX698310	C.EL	47uF 16V 066424
* C148	AA10160	C.EL	10uF 25V 066286
* C150	AA11120	C.POL	10pF 50V 055439
* C151	AA10160	C.EL	10uF 25V 066286
* C152	AA10160	C.EL	10uF 25V 066286
* C153	AA10160	C.EL	10uF 25V 066286
* C155	AA11120	C.POL	10pF 50V 055439
* C160	AA10320	C.EL	47uF 25V 066428
* C161	AA10690	C.CE.CHP	0.1uF 25V 065611
* C162	AA10690	C.CE.CHP	0.1uF 25V 065611
* C163	AA10320	C.EL	47uF 25V 066428
* C164	AA10160	C.EL	10uF 25V 066286
* C165	AA10160	C.EL	10uF 25V 066286
C167	XX698650	C.CE.CHP	100pF 50V 065858
* C168	AA10160	C.EL	10uF 25V 066286
* C170	AA10160	C.EL	10uF 25V 066286
* C171	AA10160	C.EL	10uF 25V 066286
* C172	AA10160	C.EL	10uF 25V 066286
* C301	AA11280	C.POL	0.047uF 50V 065118
* C302	AA11280	C.POL	0.047uF 50V 065118
* C303	AA10370	C.EL	4700uF 35V 066451
* C304	AA10370	C.EL	4700uF 35V 066451

* New Parts

Schm Ref.	PART NO.	Description	Remarks
* C305	AA11180	C.POL	0.1uF 50V 065007
* C306	AA10300	C.EL	33uF 16V 066389
* C308	AA10220	C.EL	1000uF 6.3V 066315
* C309	AA10410	C.EL	6800uF 16V 066466
* C311	AA10150	C.EL	10uF 16V 066282
* C312	AA11280	C.POL	0.047uF 50V 065118
* C313	AA11280	C.POL	0.047uF 50V 065118
* C314	AA10290	C.EL	2200uF 50V 066374
* C315	AA10290	C.EL	2200uF 50V 066374
C316	XX698310	C.EL	47uF 16V 066424
C317	XX698310	C.EL	47uF 16V 066424
* C318	AA10340	C.EL	47uF 50V 066432
* C319	AA10330	C.EL	47uF 35V 066430
* C320	AA10390	C.EL	4.7uF 50V 066459
* C321	AA10390	C.EL	4.7uF 50V 066459
* C322	AA10340	C.EL	47uF 50V 066432
* C323	AA10330	C.EL	47uF 35V 066430
* C324	AA10200	C.EL	100uF 25V 066305
* C325	AA10200	C.EL	100uF 25V 066305
* C328	AA10360	C.EL	470uF 35V 066445
△ C401	VS741700	C.POL	0.01uF 275V 065262
* C502	AA10720	C.CE.CHP	470pF 50V 065631
* C503	AA10730	C.CE.CHP	22pF 50V 065869
* C504	AA10250	C.EL	0.1uF 50V 066335
* C506	AA10720	C.CE.CHP	470pF 50V 065631
* C507	AA11220	C.POL	0.22uF 50V 065066
* C508	AA10250	C.EL	0.1uF 50V 066335
* C509	AA10730	C.CE.CHP	22pF 50V 065869
* C510	AA11220	C.POL	0.22uF 50V 065066
* C511	AA10160	C.EL	10uF 25V 066286
C512	XX698300	C.EL	22uF 50V 066377
* C513	AA10240	C.EL	1uF 50V 066329
* C514	AA10390	C.EL	4.7uF 50V 066459
* C515	AA10270	C.EL	22uF 25V 066347
* C516	AA10380	C.EL	4.7uF 25V 066455
* C517	AA10380	C.EL	4.7uF 25V 066455
* C518	AA10270	C.EL	22uF 25V 066347
* C519	AA10160	C.EL	10uF 25V 066286
* C520	AA10210	C.EL	100uF 50V 066311
* C521	AA10210	C.EL	100uF 50V 066311
* C522	AA10170	C.EL	100uF 6.3V 066296
* C526	AA11280	C.POL	0.047uF 50V 065118
* C527	AA11280	C.POL	0.047uF 50V 065118
* C528	AA11280	C.POL	0.047uF 50V 065118
* C529	AA11280	C.POL	0.047uF 50V 065118
* C601	AA11260	C.POL	470pF 50V 065108
* C602	AA11260	C.POL	470pF 50V 065108
* C603	AA11120	C.POL	10pF 50V 055439
* C604	AA11120	C.POL	10pF 50V 055439
* C605	AA11120	C.POL	10pF 50V 055439
* C606	AA11260	C.POL	470pF 50V 065108
* C607	AA12410	C.POL	0.18uF 50V 064917
* C608	AA11160	C.POL	0.15uF 50V 064914

* New Parts

AV-S70 P.C.B. AMP

Schm Ref.	PART NO.	Description	Remarks
* C609	AAX10430	C.EL	10uF 25V 066768
* C610	AAX10430	C.EL	10uF 25V 066768
* C611	AAX10430	C.EL	10uF 25V 066768
* C612	AAX10430	C.EL	10uF 25V 066768
* C613	AAX10440	C.EL	100uF 6.3V 066774
* C614	AAX10440	C.EL	100uF 6.3V 066774
* C615	AAX10430	C.EL	10uF 25V 066768
* C616	AAX10450	C.EL	100uF 16V 066780
* C617	AAX10430	C.EL	10uF 25V 066768
* C618	AAX10430	C.EL	10uF 25V 066768
* C619	AAX10430	C.EL	10uF 25V 066768
* C620	AAX10430	C.EL	10uF 25V 066768
* C621	AAX10430	C.EL	10uF 25V 066768
C626	XX698650	C.CE.CHP	100pF 50V 065858
C627	XX698630	C.CE.CHP	0.01uF 50V 065610
C628	XX698630	C.CE.CHP	0.01uF 50V 065610
C629	XX698630	C.CE.CHP	0.01uF 50V 065610
C630	XX698630	C.CE.CHP	0.01uF 50V 065610
C631	XX698630	C.CE.CHP	0.01uF 50V 065610
C632	XX698630	C.CE.CHP	0.01uF 50V 065610
* C635	AAX10460	C.EL	1uF 50V 066783
* C636	AAX10470	C.EL	2.2uF 50V 066799
* C638	AAX10760	C.CE.CHP	47pF 50V 065881
* C639	AAX10480	C.EL	47uF 16V 066820
* C640	AAX11150	C.POL	0.12uF 50V 064911
* C641	AAX11250	C.POL	0.033uF 50V 065092
* C642	AAX10430	C.EL	10uF 25V 066768
* C643	AAX10430	C.EL	10uF 25V 066768
* C644	AAX10460	C.EL	1uF 50V 066783
* C646	AAX10470	C.EL	2.2uF 50V 066799
* C647	AAX10760	C.CE.CHP	47pF 50V 065881
* C648	AAX10480	C.EL	47uF 16V 066820
* C649	AAX11150	C.POL	0.12uF 50V 064911
* C650	AAX11250	C.POL	0.033uF 50V 065092
* C651	AAX10430	C.EL	10uF 25V 066768
* C652	AAX10430	C.EL	10uF 25V 066768
* C653	AAX10460	C.EL	1uF 50V 066783
* C655	AAX10440	C.EL	100uF 6.3V 066774
* C656	AAX11120	C.POL	10pF 50V 055439
* C657	AAX10430	C.EL	10uF 25V 066768
* C658	AAX10430	C.EL	10uF 25V 066768
* C659	AAX10460	C.EL	1uF 50V 066783
* C661	AAX10440	C.EL	100uF 6.3V 066774
* C662	AAX11120	C.POL	10pF 50V 055439
* C665	AAX10460	C.EL	1uF 50V 066783
* C666	AAX10460	C.EL	1uF 50V 066783
CN101	VM923600	CN	52045-1345 055522
* CN102	AAX10500	CN	53291-0791 055456
* CN103	AAX10520	CN	53291-1191 055458
CN105	VM389000	CN	52045-2345 081830
* CN110	AAX10560	CN	B 3P-VH 081665
CN111	VC014600	CN	B02B-EH 081439
CN112	VL844700	CN	XH B3B 081461

* New Parts

Schm Ref.	PART NO.	Description	Remarks
* CN405	AAX10550	CN	S2P3-VH 081663
CN501	VC015000	CN	EH 6P 081522
CN502	LB932020	CN.BS.PIN	2P 081661
* CN503	AAX10570	CN	B 5P-VH 081672
* CN504	AAX10590	CN	B2P3-VH 081855
CN505	VC014800	CN	EH 4P 081493
* CN601	AAX10490	CN	52419-0790 055455
CN602	XX698170	CN	YKF51-5001 085092
* CN603	AAX10950	JACK.PIN	1P YKB11-0701 055461
* CN604	AAX10510	CN	52419-1190 055457
D101	VG439200	DIODE.ZENR	MTZJ9.1B 069148
D102	VG439200	DIODE.ZENR	MTZJ9.1B 069148
D103	VG442500	DIODE.ZENR	MTZJ5.6B 069158
D104	VG442500	DIODE.ZENR	MTZJ5.6B 069158
D105	VG442500	DIODE.ZENR	MTZJ5.6B 069158
D106	VG442500	DIODE.ZENR	MTZJ5.6B 069158
D110	iF004600	DIODE	1SS133 069460
D111	iF004600	DIODE	1SS133 069460
△ D301	VN932100	DIODE	RBV-606 055547
D302	iF004600	DIODE	1SS133 069460
D303	iF004600	DIODE	1SS133 069460
D304	iF004600	DIODE	1SS133 069460
△* D305	AAX10670	DIODE	RBV-406 055546
△* D307	AAX10670	DIODE	RBV-406 055546
* D308	AAX10770	DIODE.ZENR	ZD MTZJ10C 069160
D309	VG442500	DIODE.ZENR	MTZJ5.6B 069220
D310	VG442500	DIODE.ZENR	MTZJ5.6B 069220
D311	VG442500	DIODE.ZENR	MTZJ5.6B 069220
D313	iF004600	DIODE	1SS133 069460
D314	VU264100	DIODE	1SR139-400 069536
D501	iF004600	DIODE	1SS133 069460
D602	VG439200	DIODE.ZENR	MTZJ9.1B 069148
D603	VG439200	DIODE.ZENR	MTZJ9.1B 069148
△* F401	KB001770	FUSE	1A 250V 058323
GT103	XX698880	LUG	MET37-0001 075878
IC101	XG903A00	IC	TC4052BF 070707
IC102	XF291A00	IC	uPC4570G2 070173
IC103	XP895A00	IC	LC78212 044954
IC104	XV039A00	IC	M5220FP 055465
IC105	XV039A00	IC	M5220FP 055465
* IC106	AAX10080	IC	TC9482N 055303
IC107	XF291A00	IC	uPC4570G2 070173
△ IC120	XJ604A00	IC	NJM78M05FA 070384
△ IC121	XJ603A00	IC	NJM78M15FA 070366
△ IC122	XG505A00	IC	NJM79M15FA 070445
△ IC123	XJ604A00	IC	NJM78M05FA 070384
IC501	XV466A00	IC	LM1875T 055041
IC502	XV466A00	IC	LM1875T 055041
* IC503	AAX10070	IC	TRUBASS 055300
IC601	XF291A00	IC	uPC4570G2 070173
IC602	XF291A00	IC	uPC4570G2 070173
IC603	XF291A00	IC	uPC4570G2 070173
IC604	XF293A00	IC	CMOS 4066FLT 070715

* New Parts

AV-S70 P.C.B. AMP & DSP-FL

Schm Ref.	PART NO.	Description	Remarks
* IC605	XF291A00	IC	uPC4570G2 070173
* JK101	AAX10960	JACK.PIN	HSP-248V1 056838
Q101	iE101280	FET	2SK105 T 055462
Q102	iE101280	FET	2SK105 T 055462
Q103	iC287820	TR	2SC2878 A,B 068813
Q104	iC287820	TR	2SC2878 A,B 068813
Q105	VD678500	TR	DTA114ESA 069248
Q106	VD678700	TR	DTC114ESA 069299
Q107	VD678700	TR	DTC114ESA 069299
Q110	iC174020	TR	2SC1740S QRS 055717
△ Q113	VK407600	TR	2SC 4208A QRS 055469
△ Q114	VG722000	TR	DTC144ESA 069303
△ Q115	VR510800	TR	2SD2396 JK 055467
△ Q117	VE613300	TR	2SB1237 TV2 QR 057100
△ Q118	VS883300	TR	2SB1565 E,F 044140
Q501	iC287820	TR	2SC2878 A,B 068813
Q502	iC287820	TR	2SC2878 A,B 068813
Q503	iC287820	TR	2SC2878 A,B 068813
Q504	iC174020	TR	2SC1740S QRS 055717
Q505	iC174020	TR	2SC1740S QRS 055717
Q506	iC287820	TR	2SC2878 A,B 068813
Q601	iC287820	TR	2SC2878 A,B 068813
Q602	iC287820	TR	2SC2878 A,B 068813
Q603	iC287820	TR	2SC2878 A,B 068813
Q604	iC287820	TR	2SC2878 A,B 068813
Q606	VG722000	TR	DTC144ESA 069303
Q607	VG722000	TR	DTC144ESA 069303
* R132	AAX11870	R.CAR.FP	10Ω 1/4W 044452
* R134	AAX11870	R.CAR.FP	10Ω 1/4W 044452
* R159	AAX11870	R.CAR.FP	10Ω 1/4W 044452
* R160	AAX11870	R.CAR.FP	10Ω 1/4W 044452
* R166	AAX11870	R.CAR.FP	10Ω 1/4W 044452
* R174	AAX11870	R.CAR.FP	10Ω 1/4W 044452
* R175	AAX11870	R.CAR.FP	10Ω 1/4W 044452
* R186	AAX11870	R.CAR.FP	10Ω 1/4W 044452
* R187	AAX11870	R.CAR.FP	10Ω 1/4W 044452
* R188	AAX11870	R.CAR.FP	10Ω 1/4W 044452
R199	HV754220	R.CAR.FP	22Ω 1/4W 067488
R200	HV754220	R.CAR.FP	22Ω 1/4W 067488
* R324	AAX11910	R.CAR.FP	5.6KΩ 1/4W 055505
* R325	AAX11940	R.CAR.FP	1.5KΩ 1/4W 055975
* R326	AAX11880	R.CAR.FP	1KΩ 1/4W 044454
* R328	AAX11940	R.CAR.FP	1.5KΩ 1/4W 055975
* R329	AAX11880	R.CAR.FP	1KΩ 1/4W 044454
* R331	AAX11380	R.CAR.CHIP	43KΩ 1/8W 053202
* R333	AAX11860	R.CAR.FP	100Ω 1/4W 044153
△ * R335	AAX11850	R.MTL.FLM	27Ω 1W 067950
△ * R336	AAX11850	R.MTL.FLM	27Ω 1W 067950
△ R337	VK186900	R.FUS	18Ω 1/4W 057098
△ R338	VK186900	R.FUS	18Ω 1/4W 057098
△ R339	VE009700	R.FUS	100Ω 1/4W 057099
△ R340	VE009700	R.FUS	100Ω 1/4W 057099
* R341	AAX11950	R.CAR.FP	1Ω 1/4W 084665

* New Parts

Schm Ref.	PART NO.	Description	Remarks
* R401	AAX11900	R.CAR.FP	2.2Ω 1/4W 055504
* R402	AAX11900	R.CAR.FP	2.2Ω 1/4W 055504
* R513	AAX11930	R.CAR.FP	820Ω 1/4W 055507
* R517	AAX11920	R.CAR.FP	6.8Ω 1/4W 055506
* R522	AAX11920	R.CAR.FP	6.8Ω 1/4W 055506
* R527	AAX11860	R.CAR.FP	100Ω 1/4W 044153
* R629	AAX11870	R.CAR.FP	10Ω 1/4W 044452
* R630	AAX11870	R.CAR.FP	10Ω 1/4W 044452
* R670	AAX11870	R.CAR.FP	10Ω 1/4W 044452
* R671	AAX11870	R.CAR.FP	10Ω 1/4W 044452
* R685	AAX11890	R.CAR.FP	1.2KΩ 1/4W 055503
* R686	AAX11890	R.CAR.FP	1.2KΩ 1/4W 055503
* R691	AAX11870	R.CAR.FP	10Ω 1/4W 044452
* R692	AAX11870	R.CAR.FP	10Ω 1/4W 044452
RY301	VV272600	RELAY	OSA-SS-224-DM5 079770
RY501	VU161600	RELAY	OSA-SS-224DM3 079766
ST401	XX707320	PIN	IPS-5007 064821
ST402	XX707320	PIN	IPS-5007 064821
ST601	BB071360	TERM	EARTH 055265
△ * SW401	AAX10640	SWITCH	SDDL1-B1-F 055466
△ * T401	XY773A00	TRANS.PWR	059489
△ TH401	VT865700	POSISTOR	PTH8L14AR0R5MIC030 068537
	VP206500	HOLDER.FUS	EYF-52BCT 074277
* AAX10890		HEAT.SINK	UOT-16CS25-MP 055523
* AAX10900		HEAT.SINK	DPS35-40 055524
* AAX10910		HEAT.SINK	PH-0124B-S 064564
* AAX10800		SCR.PAN.HD	3x12 ZC 075255
BB070700		GND.MTL	075884
	AAX15140	P.C.B.	DSP-FL 331415
C1	XX698650	C.CE.CHP	100pF 50V 065858
* C2	AAX10690	C.CE.CHP	0.1uF 25V 065611
C3	XX698650	C.CE.CHP	100pF 50V 065858
* C7	AAX10740	C.CE.CHP	33pF 50V 065876
* C8	AAX10690	C.CE.CHP	0.1uF 25V 065611
* C9	AAX10690	C.CE.CHP	0.1uF 25V 065611
C11	XX698650	C.CE.CHP	100pF 50V 065858
C12	XX698650	C.CE.CHP	100pF 50V 065858
C13	XX698650	C.CE.CHP	100pF 50V 065858
* C14	AAX10690	C.CE.CHP	0.1uF 25V 065611
* C15	AAX10680	C.CE.CHP	1000pF 50V 065609
* C16	AAX10740	C.CE.CHP	33pF 50V 065876
* C17	AAX10690	C.CE.CHP	0.1uF 25V 065611
* C18	AAX11280	C.POL	0.047uF 50V 065118
* C19	AAX11270	C.POL	4700pF 50V 065111
* C20	AAX10690	C.CE.CHP	0.1uF 25V 065611
* C21	AAX10170	C.EL	100uF 6.3V 066296
C23	XX698650	C.CE.CHP	100pF 50V 065858
C24	XX698650	C.CE.CHP	100pF 50V 065858
C25	XX698650	C.CE.CHP	100pF 50V 065858
* C26	AAX10690	C.CE.CHP	0.1uF 25V 065611

* New Parts

AV-S70/NX-SW70

AV-S70 P.C.B. DSP-FL

Schm Ref.	PART NO.	Description	Remarks
* C27	AAX10710	C.CE.CHP	0.022uF 50V 065621
* C28	AAX10690	C.CE.CHP	0.1uF 25V 065611
* C29	AAX10690	C.CE.CHP	0.1uF 25V 065611
* C30	AAX10750	C.CE.CHP	39pF 50V 065879
* C31	AAX10740	C.CE.CHP	33pF 50V 065876
C32	XX698650	C.CE.CHP	100pF 50V 065858
C33	XX698650	C.CE.CHP	100pF 50V 065858
C34	XX698650	C.CE.CHP	100pF 50V 065858
C35	XX698650	C.CE.CHP	100pF 50V 065858
* C36	AAX10170	C.EL	100uF 6.3V 066296
C37	XX698650	C.CE.CHP	100pF 50V 065858
C38	XX698650	C.CE.CHP	100pF 50V 065858
C39	XX698650	C.CE.CHP	100pF 50V 065858
C40	XX698650	C.CE.CHP	100pF 50V 065858
C41	XX698650	C.CE.CHP	100pF 50V 065858
* C42	AAX10310	C.EL	330uF 6.3V 066397
* C43	AAX10310	C.EL	330uF 6.3V 066397
* C44	AAX10690	C.CE.CHP	0.1uF 25V 065611
* C45	AAX10690	C.CE.CHP	0.1uF 25V 065611
* C46	AAX10690	C.CE.CHP	0.1uF 25V 065611
* C48	AAX10310	C.EL	330uF 6.3V 066397
* C49	AAX10690	C.CE.CHP	0.1uF 25V 065611
* C50	AAX10720	C.CE.CHP	470pF 50V 065631
* C51	AAX10690	C.CE.CHP	0.1uF 25V 065611
* C52	AAX10690	C.CE.CHP	0.1uF 25V 065611
* C53	AAX10310	C.EL	330uF 6.3V 066397
* C54	AAX10690	C.CE.CHP	0.1uF 25V 065611
* C55	AAX10310	C.EL	330uF 6.3V 066397
* C56	AAX10690	C.CE.CHP	0.1uF 25V 065611
* C57	AAX10690	C.CE.CHP	0.1uF 25V 065611
* C58	AAX10310	C.EL	330uF 6.3V 066397
* C59	AAX10690	C.CE.CHP	0.1uF 25V 065611
* C60	AAX10170	C.EL	100uF 6.3V 066296
* C61	AAX10690	C.CE.CHP	0.1uF 25V 065611
* C62	AAX10230	C.EL	1000uF 10V 066316
* C63	AAX10230	C.EL	1000uF 10V 066316
* C64	AAX10280	C.EL	220uF 10V 066359
* C65	AAX10690	C.CE.CHP	0.1uF 25V 065611
* C66	AAX11170	C.POL	0.47uF 50V 064936
* C67	AAX10170	C.EL	100uF 6.3V 066296
* C68	AAX10400	C.EL	0.47uF 50V 066462
* C69	AAX11210	C.POL	1500pF 50V 065028
* C70	AAX11210	C.POL	1500pF 50V 065028
* C71	AAX10160	C.EL	10uF 25V 066286
* C72	AAX11240	C.POL	3300pF 50V 065087
* C73	AAX11240	C.POL	3300pF 50V 065087
* C74	AAX10160	C.EL	10uF 25V 066286
* C75	AAX10160	C.EL	10uF 25V 066286
* C76	AAX11190	C.POL	1200pF 50V 065014
* C77	AAX11230	C.POL	0.27uF 50V 065082
* C78	AAX10160	C.EL	10uF 25V 066286
* C79	AAX10160	C.EL	10uF 25V 066286
* C80	AAX11240	C.POL	3300pF 50V 065087

* New Parts

Schm Ref.	PART NO.	Description	Remarks
* C81	AAX11240	C.POL	3300pF 50V 065087
* C81	AAX11240	C.POL	3300pF 50V 065087
* C82	AAX10160	C.EL	10uF 25V 066286
* C83	AAX11120	C.POL	10pF 50V 055439
* C84	AAX11120	C.POL	10pF 50V 055439
* C85	AAX11120	C.POL	10pF 50V 055439
* C86	AAX11130	C.POL	220pF 50V 055447
* C87	AAX10160	C.EL	10uF 25V 066286
* C88	AAX10160	C.EL	10uF 25V 066286
* C89	AAX11120	C.POL	10pF 50V 055439
* C90	AAX11130	C.POL	220pF 50V 055447
* C91	AAX11120	C.POL	10pF 50V 055439
* C92	AAX11140	C.POL	6200pF 50V 055501
* C93	AAX11120	C.POL	10pF 50V 055439
* C94	AAX11130	C.POL	220pF 50V 055447
* C95	AAX10160	C.EL	10uF 25V 066286
* C96	AAX10160	C.EL	10uF 25V 066286
* C97	AAX11120	C.POL	10pF 50V 055439
* C98	AAX11130	C.POL	220pF 50V 055447
* C99	AAX11120	C.POL	10pF 50V 055439
* C701	AAX10230	C.EL	1000uF 10V 066316
* C702	AAX10420	C.EL	10uF 16V 066763
* C703	AAX10690	C.CE.CHP	0.1uF 25V 065611
* C704	AAX10460	C.EL	1uF 50V 066783
C705	XX698630	C.CE.CHP	0.01uF 50V 065610
* C706	AAX10440	C.EL	100uF 6.3V 066774
* C800	AAX10260	C.EL	22uF 16V 066345
* C801	AAX10320	C.EL	47uF 25V 066428
* C802	AAX11170	C.POL	0.47uF 50V 064936
* C803	AAX10320	C.EL	47uF 25V 066428
* C804	AAX10260	C.EL	22uF 16V 066345
* C805	AAX11120	C.POL	10pF 50V 055439
C806	XX698650	C.CE.CHP	100pF 50V 065858
C807	XX698650	C.CE.CHP	100pF 50V 065858
C808	XX698650	C.CE.CHP	100pF 50V 065858
C810	XX698650	C.CE.CHP	100pF 50V 065858
C811	XX698650	C.CE.CHP	100pF 50V 065858
C812	XX698650	C.CE.CHP	100pF 50V 065858
* C813	AAX10350	C.EL	470uF 6.3V 066436
* C814	AAX10690	C.CE.CHP	0.1uF 25V 065611
C815	XX698650	C.CE.CHP	100pF 50V 065858
C816	XX698650	C.CE.CHP	100pF 50V 065858
* C817	AAX10690	C.CE.CHP	0.1uF 25V 065611
* C818	AAX10690	C.CE.CHP	0.1uF 25V 065611
* C819	AAX10690	C.CE.CHP	0.1uF 25V 065611
* C820	AAX11110	C.POL	330pF 50V 050158
C821	UB012560	R.CAR.CHP	560pF 50V 065888
C822	UB012560	R.CAR.CHP	560pF 50V 065888
C823	UB012560	R.CAR.CHP	560pF 50V 065888
C824	UB012560	R.CAR.CHP	560pF 50V 065888
C825	UB012560	R.CAR.CHP	560pF 50V 065888
C826	UB012560	R.CAR.CHP	560pF 50V 065888
* C851	AAX10730	C.CE.CHP	22pF 50V 065869

* New Parts

AV-S70 P.C.B. DSP-FL

Schm Ref.	PART NO.	Description	Remarks
* C852	AAX10690	C.CE.CHP 0.1uF 25V	065611
* C853	AAX10690	C.CE.CHP 0.1uF 25V	065611
* C854	AAX10690	C.CE.CHP 0.1uF 25V	065611
* C855	AAX10180	C.EL 100uF 10V	066298
* C856	AAX10690	C.CE.CHP 0.1uF 25V	065611
* C857	AAX10270	C.EL 22uF 25V	066347
CB1	VQ044400	CN 52044-09	055032
CB2	VF982300	CN 52044-1745	055308
CB3	VM923600	CN 52045-1345	055522
CB4	VQ047200	CN 52045-09	055033
CB701	VC016100	CN EH 3P L	081469
* CB702	AAX10540	CN 52492-1720	055904
* CB703	AAX10580	CN 52492-2320	081831
* CB704	AAX10530	CN 52492-0920	055903
D1	XX698570	DIODE ISS355	069444
D2	XX698570	DIODE ISS355	069444
D3	XX698570	DIODE ISS355	069444
D4	XX698570	DIODE ISS355	069444
D5	XX698570	DIODE ISS355	069444
D6	XX698570	DIODE ISS355	069444
D7	XX698570	DIODE ISS355	069444
D8	XX698570	DIODE ISS355	069444
D9	XX698570	DIODE ISS355	069444
D10	XX698570	DIODE ISS355	069444
D11	XX698570	DIODE ISS355	069444
D12	XX698570	DIODE ISS355	069444
D701	VU171900	DIODE.ZENR UDZ5.1B	048310
D702	VU171900	DIODE.ZENR UDZ5.1B	048310
D703	XX698570	DIODE ISS355	069444
D704	XX698570	DIODE ISS355	069444
D705	VU172200	DIODE.ZENR UDZ6.8B	043218
D706	XX698570	DIODE ISS355	069444
D707	VT439400	LED(re) SLR-342VC RED	069822
D708	VU171900	DIODE.ZENR UDZ5.1B	048310
G3	XX698880	LUG MET37-0001	075878
IC1	XR038A00	IC NJM2904M T1	070192
IC2	XL091A00	IC HD74HC02FPEL	055305
IC3	XG948E00	IC YM3436	055299
IC4	XU728A00	IC YSS908-F U-PK10	055298
IC6	XW233A00	IC CS4227-KQ 44PIN	055302
IC7	XW728A00	IC LP61256GS-8	055296
IC8	XV039A00	IC M5220FP	055465
IC9	XV039A00	IC M5220FP	055465
IC10	XV039A00	IC M5220FP	055465
IC11	XV039A00	IC M5220FP	055465
IC12	XV039A00	IC M5220FP	055465
IC15	XU965A00	IC uPC29M33T-E1	055304
* IC701	XY514A00	IC M30217MA-A201FP	058130
* IC702	AAX10090	IC S-29390AFJA TB	055306
IC801	XS993A00	IC TC74HCU04AF T	070867
IC802	XR042A00	IC TC74HC153AF	070781
JK801	V2508700	CN.PHOT.SN GP1F37R	055510
L1	GE300610	FER.CORE FERITE CORE BL02RN	073729

* New Parts

Schm Ref.	PART NO.	Description	Remarks
L801	GE901970	COIL CHK LAV35VB 680K	055508
* PJ801	AAX10970	JACK.PIN YKC21-3627	057529
Q1	VV655200	TR DTA143EKA T146	055311
Q2	VD303700	TR 2SC3326 B TE85L	068835
Q701	XX698710	TR DTA144EK	069270
Q702	XX698710	TR DTA144EK	069270
Q703	VE613400	TR 2SD1858 QR	068959
Q704	VE613400	TR 2SD1858 QR	068959
Q705	XX698720	TR DTC144EK	069311
Q706	VV556500	TR 2SA1037K QRS	068590
Q707	XX698710	TR DTA144EK	069270
Q708	XX698720	TR DTC144EK	069311
Q710	XX698710	TR DTA144EK	069270
Q711	XX698710	TR DTA144EK	069270
* R40	AAX11900	R.CAR.FP 2.2Ω 1/4W	055504
* R45	AAX11900	R.CAR.FP 2.2Ω 1/4W	055504
* R46	AAX11900	R.CAR.FP 2.2Ω 1/4W	055504
* R49	AAX11870	R.CAR.FP 10Ω 1/4W	044452
* R50	AAX11950	R.CAR.FP 1Ω 1/4W	084665
* R95	AAX11900	R.CAR.FP 2.2Ω 1/4W	055504
* R96	AAX11900	R.CAR.FP 2.2Ω 1/4W	055504
* R767	AAX11860	R.CAR.FP 100Ω 1/4W	044153
* R768	AAX11860	R.CAR.FP 100Ω 1/4W	044153
* R856	AAX11900	R.CAR.FP 2.2Ω 1/4W	055504
* SW701	AAX10660	SW.TACT SKHVBL038A	072692
* SW702	AAX10660	SW.TACT SKHVBL038A	072692
* SW703	AAX10660	SW.TACT SKHVBL038A	072692
* SW704	AAX10660	SW.TACT SKHVBL038A	072692
* SW705	AAX10660	SW.TACT SKHVBL038A	072692
U701	VU591000	L.DTCT GP1U271X	055310
V701	V4879700	FL.DSPLY 13-BT-169GNK	055511
XL1	Vi552000	RSNR.CRYS AT-49 12.288MHZ	055312
XL701	VQ791000	RSNR.CE CST10.0MTW-TF01	055042
* AAX10100		LED.SPACER LH-5-6	076001
* AAX10140		CUSHION	055172
* AAX12950		SHEET SHIELD	057863
* AAX12960		SHEET INSULATOR	057864

* New Parts

AV-S70/NX-SW70

CHIP RESISTORS

Schm Ref.	PART NO.	Description	Remarks
*	RD256430	R.CAR.CHP 4.3KΩ 1/8W	067775
*	RD257300	R.CAR.CHP 30KΩ 1/8W	067753
*	AAX11390	R.CAR.CHP 36KΩ 1/8W	055459
*	AAX11400	R.CAR.CHP 16KΩ 1/8W	055521
*	AAX11410	R.CAR.CHP 51Ω 1/8W	056520
*	AAX11420	R.CAR.CHP 1KΩ 1/8W	067679
*	AAX11430	R.CAR.CHP 1MΩ 1/8W	067686
*	AAX11440	R.CAR.CHP 1Ω 1/8W	067689
*	AAX11450	R.CAR.CHP 1.1KΩ 1/8W	067690
*	AAX11460	R.CAR.CHP 11KΩ 1/8W	067691
*	AAX11470	R.CAR.CHP 1.2KΩ 1/8W	067696
*	AAX11480	R.CAR.CHP 12KΩ 1/8W	067698
*	AAX11500	R.CAR.CHP 1.8KΩ 1/8W	067716
*	AAX11510	R.CAR.CHP 18KΩ 1/8W	067718
*	AAX11520	R.CAR.CHP 180KΩ 1/8W	067719
*	AAX11530	R.CAR.CHP 8.2KΩ 1/8W	067726
*	AAX11540	R.CAR.CHP 200KΩ 1/8W	067728
*	AAX11560	R.CAR.CHP 22KΩ 1/8W	067734
*	AAX11570	R.CAR.CHP 220KΩ 1/8W	067736
*	AAX11580	R.CAR.CHP 24KΩ 1/8W	067741
*	AAX11590	R.CAR.CHP 2.7KΩ 1/8W	067745
*	AAX11600	R.CAR.CHP 27KΩ 1/8W	067747
*	AAX11610	R.CAR.CHP 3KΩ 1/8W	067751
*	AAX11620	R.CAR.CHP 330Ω 1/8W	067756
*	AAX11630	R.CAR.CHP 33KΩ 1/8W	067760
*	AAX11640	R.CAR.CHP 3.6KΩ 1/8W	067764
*	AAX11650	R.CAR.CHP 390Ω 1/8W	067767
*	AAX11660	R.CAR.CHP 3.9KΩ 1/8W	067769
*	AAX11670	R.CAR.CHP 39KΩ 1/8W	067771
*	AAX11680	R.CAR.CHP 47Ω 1/8W	067776
*	AAX11690	R.CAR.CHP 470Ω 1/8W	067777
*	AAX11700	R.CAR.CHP 470KΩ 1/8W	067782
*	AAX11710	R.CAR.CHP 4.7Ω 1/8W	067785
*	AAX11730	R.CAR.CHP 5.1KΩ 1/8W	067788
*	AAX11740	R.CAR.CHP 51KΩ 1/8W	067789
*	AAX11750	R.CAR.CHP 5.6KΩ 1/8W	067796
*	AAX11760	R.CAR.CHP 56KΩ 1/8W	067798
*	AAX11770	R.CAR.CHP 6.2KΩ 1/8W	067800
*	AAX11780	R.CAR.CHP 62KΩ 1/8W	067801
*	AAX11790	R.CAR.CHP 680Ω 1/8W	067804
*	AAX11800	R.CAR.CHP 68KΩ 1/8W	067807
*	AAX11810	R.CAR.CHP 82Ω 1/8W	067813
*	AAX11820	R.CAR.CHP 820Ω 1/8W	067814
*	AAX11830	R.CAR.CHP 8.2KΩ 1/8W	067816
*	AAX11840	R.CAR.CHP 82KΩ 1/8W	067817
*	AAX12770	R.CAR.CHP 47Ω 1/8W	067781
	HX608670	R.CAR.CHP 120Ω 1/8W	067694
	XX698990	R.CAR.CHP 0Ω 1/8W	067674
	XX699000	R.CAR.CHP 100Ω 1/8W	067677
	XX699010	R.CAR.CHP 10KΩ 1/8W	067681
	XX699020	R.CAR.CHP 100KΩ 1/8W	067683
	XX699030	R.CAR.CHP 2KΩ 1/8W	067724
	XX699040	R.CAR.CHP 220Ω 1/8W	067730

* New Parts

Schm Ref.	PART NO.	Description	Remarks
	XX699050	R.CAR.CHP 2.2KΩ 1/8W	067732
	XX699060	R.CAR.CHP 3.3KΩ 1/8W	067758
	XX699070	R.CAR.CHP 4.7KΩ 1/8W	067779

* New Parts

SW-AVS70 P.C.B. AMP

Schm Ref.	PART NO.	Description	Remarks
* C101	AAX12780	P.C.B. AMP	057955
* C102	AAX10260	C.EL 22uF 16V	066345
* C103	AAX10260	C.EL 22uF 16V	066345
* C104	AAX10150	C.EL 10uF 16V	066282
* C105	AAX10150	C.EL 10uF 16V	066282
* C106	AAX11120	C.POL 10pF 50V	055439
* C107	AAX11120	C.POL 10pF 50V	055439
* C108	AAX10380	C.EL 4.7uF 25V	066455
* C109	AAX10380	C.EL 4.7uF 25V	066455
* C110	AAX11120	C.POL 10pF 50V	055439
* C111	XX698300	C.EL 22uF 50V	066377
* C112	XX698300	C.EL 22uF 50V	066377
* C113	AAX11260	C.POL 470pF 50V	065108
* C114	AAX11260	C.POL 470pF 50V	065108
* C115	AAX12440	C.POL 0.027uF 50V	065076
* C116	AAX12440	C.POL 0.027uF 50V	065076
* C117	AAX12440	C.POL 0.027uF 50V	065076
* C118	AAX12440	C.POL 0.027uF 50V	065076
* C119	AAX10190	C.EL 100uF 6.3V	066302
* C120	AAX10190	C.EL 100uF 6.3V	066302
* C121	AAX09490	C.CE 22pF 50V	051094
* C122	AAX09490	C.CE 22pF 50V	051094
* C123	AAX10210	C.EL 100uF 50V	066311
* C124	AAX10210	C.EL 100uF 50V	066311
* C125	AAX12070	C.EL 10uF 35V	066288
* C126	AAX12070	C.EL 10uF 35V	066288
* C127	AAX12400	C.POL 560pF 50V	055500
* C128	AAX12400	C.POL 560pF 50V	055500
* C129	AAX10240	C.EL 1uF 50V	066329
* C130	AAX11280	C.POL 0.047uF 50V	065118
* C131	AAX11280	C.POL 0.047uF 50V	065118
* C132	AAX10170	C.EL 100uF 6.3V	066296
* C133	AAX10260	C.EL 22uF 16V	066345
* C134	AAX10150	C.EL 10uF 16V	066282
* C135	AAX10150	C.EL 10uF 16V	066282
* C136	AAX11120	C.POL 10pF 50V	055439
* C137	AAX10380	C.EL 4.7uF 25V	066455
* C138	AAX11120	C.POL 10pF 50V	055439
* C139	XX698300	C.EL 22uF 50V	066377
* C140	AAX12420	C.POL 0.22uF 50V	064921
* C141	AAX12420	C.POL 0.22uF 50V	064921
* C142	AAX11170	C.POL 0.47uF 50V	064936
* C143	AAX10150	C.EL 10uF 16V	066282
* C144	AAX10150	C.EL 10uF 16V	066282
* C145	AAX12430	C.POL 0.39uF 50V	064932
* C146	AAX11160	C.POL 0.15uF 50V	064914
* C147	AAX12270	C.EL 330uF 16V	066402
* C148	AAX12450	C.POL 3900pF 50V	065099
* C149	AAX11170	C.POL 0.47uF 50V	064936
* C151	AAX11270	C.POL 4700pF 50V	065111
* C152	AAX12260	C.EL 33uF 25V	066391
* C153	AAX12410	C.POL 0.18uF 50V	064917

* New Parts

Schm Ref.	PART NO.	Description	Remarks
* C154	AAX11180	C.POL 0.1uF 50V	065007
* C155	AAX10150	C.EL 10uF 16V	066282
* C156	AAX10150	C.EL 10uF 16V	066282
* C157	AAX10150	C.EL 10uF 16V	066282
* C158	AAX12270	C.EL 330uF 16V	066402
* C159	AAX12270	C.EL 330uF 16V	066402
* C160	AAX12250	C.EL 22uF 50V	066352
* C161	AAX12250	C.EL 22uF 50V	066352
* C162	AAX12060	C.EL 8200uF 35V	056032
* C163	AAX12060	C.EL 8200uF 35V	056032
* C164	AAX11280	C.POL 0.047uF 50V	065118
* C165	AAX11280	C.POL 0.047uF 50V	065118
* C166	AAX10150	C.EL 10uF 16V	066282
* C167	AAX12180	C.CE 0.01uF 50V	065944
* C168	VS741700	C.POL 0.01uF 275V	065262
* C173	AAX12180	C.CE 0.01uF 50V	065944
* C174	AAX12170	C.CE 100pF 50V	051723
* C175	AAX11120	C.POL 10pF 50V	055439
* C176	AAX12180	C.CE 0.01uF 50V	065944
* C177	AAX11120	C.POL 10pF 50V	055439
* C178	AAX11120	C.POL 10pF 50V	055439
* C179	AAX12180	C.CE 0.01uF 50V	065944
* C181	AAX10240	C.EL 1uF 50V	066329
* C182	AAX11180	C.POL 0.1uF 50V	065007
* C183	AAX11180	C.POL 0.1uF 50V	065007
* C184	AAX10240	C.EL 1uF 50V	066329
* CN103	AAX10570	CN B 5P-VH	081672
* CN105	AAX12210	CN 10P	081553
* CN107	AAX12200	CN 4P-VH	081669
* D101	iF004600	DIODE 1SS133	069460
* D102	iF004600	DIODE 1SS133	069460
* D103	iF004600	DIODE 1SS133	069460
* D104	iF004600	DIODE 1SS133	069460
* D105	iF004600	DIODE 1SS133	069460
* D106	iF004600	DIODE 1SS133	069460
* D107	AAX12620	DIODE.ZENR MTZJ5.6B	069099
* D108	iF004600	DIODE 1SS133	069460
* D109	AAX12240	DIODE RBV602	069599
* D110	iF004600	DIODE 1SS133	069460
* D111	iF004600	DIODE 1SS133	069460
* D112	iF004600	DIODE 1SS133	069460
* D113	iF004600	DIODE 1SS133	069460
* F101	KB000680	FUSE 1.25A 250V	044013
* IC101	XB247A00	IC uPC4570HA	070111
* IC102	XB247A00	IC uPC4570HA	070111
* IC103	XB247A00	IC uPC4570HA	070111
* IC104	XB247A00	IC uPC4570HA	070111
* IC105	XB247A00	IC uPC4570HA	070111
* IC106	AAX11990	IC NJM78M12FA	070371
* IC107	AAX12000	IC NJM79M12FA	070447
* IC108	AAX11980	IC AN78N12	055476
* IC109	AAX11970	IC STK408-040E	049670
* JK101	XX698170	CN YKF51-5001	085092

* New Parts

AV-S70/NX-SW70

SW-AVS70 P.C.B. AMP

Schm Ref.	PART NO.	Description	Remarks
* L101	AAX12190	COIL.CHOKE 1.5uH	074417
* L102	AAX12190	COIL.CHOKE 1.5uH	074417
* L103	AAX12190	COIL.CHOKE 1.5uH	074417
Q101	iC287820	TR 2SC2878 A,B	068813
Q102	iC287820	TR 2SC2878 A,B	068813
* Q103	AAX12590	TR 2SC2240 GR BL	073532
* Q104	AAX12590	TR 2SC2240 GR BL	073532
* Q105	AAX12580	TR 2SA970 GR BL	073509
Q106	iC287820	TR 2SC2878 A,B	068813
Q107	iC174020	TR 2SC1740S QRS	055717
* Q109	AAX12590	TR 2SC2240 GR BL	073532
* Q110	AAX12580	TR 2SA970 GR BL	073509
* Q111	AAX12590	TR 2SC2240 GR BL	073532
* Q112	AAX12580	TR 2SA970 GR BL	073509
Q113	iC287820	TR 2SC2878 A,B	068813
Q114	iC174020	TR 2SC1740S QRS	055717
* Q115	AAX09180	FET 2SK304 E	051061
* Q116	AAX12580	TR 2SA970 GR BL	073509
Q117	VD678700	TR DTC114ESA	069299
Q118	iC174020	TR 2SC1740S QRS	055717
* R101	AAX09880	R.CAR.FP 22Ω 1/4W	054214
* R102	AAX09880	R.CAR.FP 22Ω 1/4W	054214
* R125	AAX11860	R.CAR.FP 100Ω 1/4W	044153
* R126	AAX11860	R.CAR.FP 100Ω 1/4W	044153
* R130	AAX12360	R.MTL.PLAT 0.22Ω 3W	055474
* R131	AAX12360	R.MTL.PLAT 0.22Ω 3W	055474
* R141	AAX11870	R.CAR.FP 10Ω 1/4W	044452
* R142	AAX11870	R.CAR.FP 10Ω 1/4W	044452
* R147	AAX09880	R.CAR.FP 22Ω 1/4W	054214
* R148	AAX09880	R.CAR.FP 22Ω 1/4W	054214
* R166	AAX11860	R.CAR.FP 100Ω 1/4W	044153
* R167	AAX11880	R.CAR.FP 1KΩ 1/4W	044454
* R168	AAX11880	R.CAR.FP 1KΩ 1/4W	044454
* R177	AAX11900	R.CAR.FP 2.2Ω 1/4W	055504
* R178	AAX11930	R.CAR.FP 820Ω 1/4W	055507
* R179	AAX11870	R.CAR.FP 10Ω 1/4W	044452
R184	VP441400	R.MTL.FLM 10KΩ 1/4W	068279
R185	VP441400	R.MTL.FLM 10KΩ 1/4W	068279
* R186	AAX09780	R.MTL.FLM 20KΩ 1/4W	068187
R187	VP441400	R.MTL.FLM 10KΩ 1/4W	068279
* R195	AAX12370	R.MTL.PLAT 0.1Ω 3W	055475
△ * R198	AAX12280	R.CAR.FP 4.7Ω 1/4W	044143
△ * R199	AAX12280	R.CAR.FP 4.7Ω 1/4W	044143
* R203	AAX11870	R.CAR.FP 10Ω 1/4W	044452
* R204	AAX11870	R.CAR.FP 10Ω 1/4W	044452
* R205	AAX11870	R.CAR.FP 10Ω 1/4W	044452
* R207	AAX11950	R.CAR.FP 1Ω 1/4W	084665
* R212	AAX12350	R.MTL.FLM 330Ω 1W	068020
RY101	VU161600	RELAY OSA-SS-224DM3	079766
* RY102	AAX12480	RELAY DQ24D1-0S	055472
△ * RY103	AAX12490	RELAY SDT-S-112LMR	055473
* SP101	AAX12530	TERM.SP CJ-9023-06	055468
TM101	XX707320	PIN IPS-5007	064821

* New Parts

Schm Ref.	PART NO.	Description	Remarks
TM102	XX707320	PIN	IPS-5007 064821
	VP206500	HOLDER.FUS	EYF-52BCT 074277
*	AAX10900	HEAT.SINK	DPS35-40 055524
*	AAX10800	SCR.PAN.HD	3x12 ZC 075255
*	AAX12080	SCR.BND.HD	3x6 ZC 075633

* New Parts

AV-S70/NX-SW70

■ AV-S70 EXPLODED VIEW

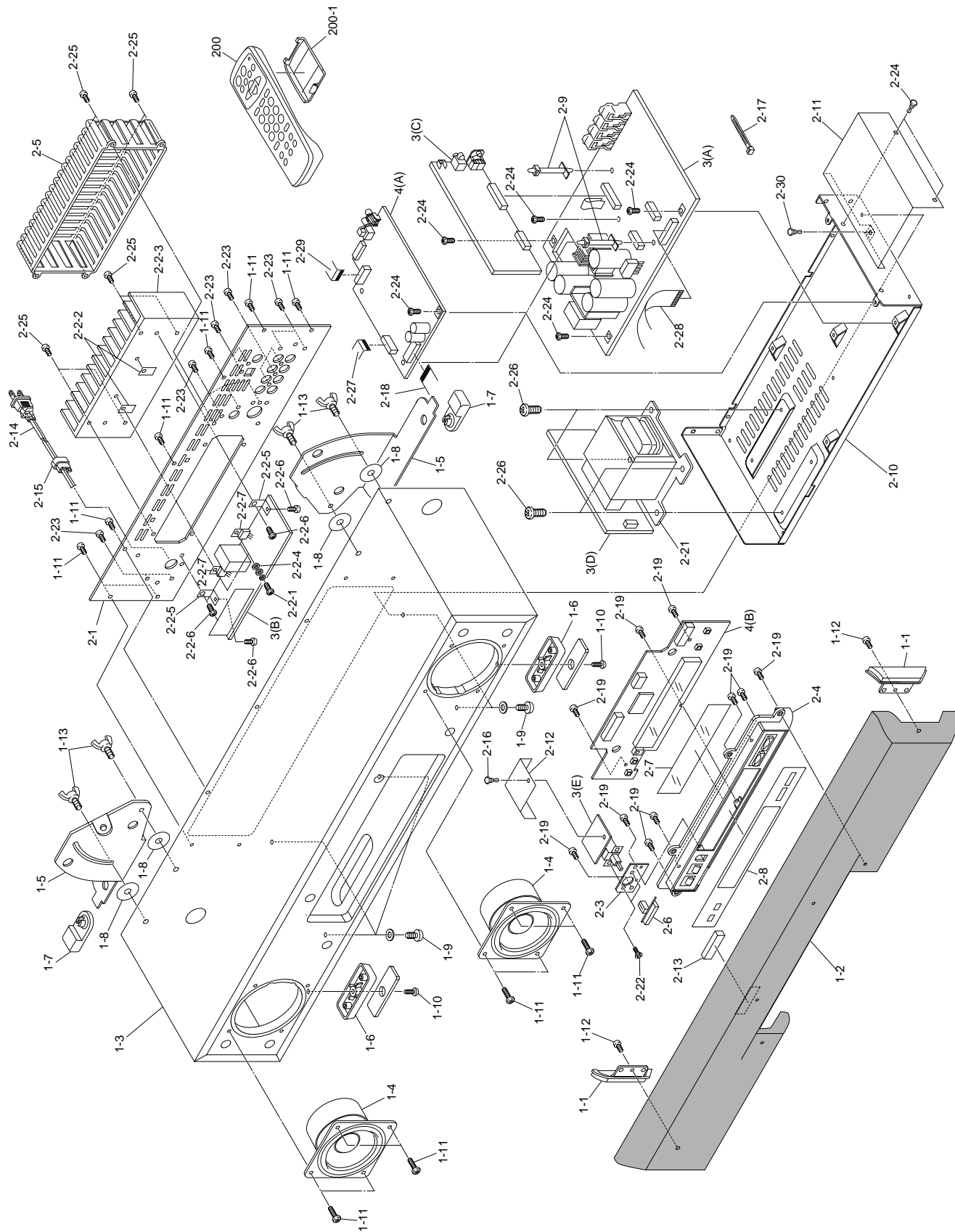

■ AV-S70 MECHANICAL PARTS

Ref. No.	PART NO.	Description	Remarks	Markets
* 1-1	AAX10600	SIDE PANEL	R	054960
* 1-1	AAX10610	SIDE PANEL	L	054962
* 1-2	AAX11040	GRILLE ASS'Y		055653
* 1-3	AAX11330	ENCLOSURE		055073
1-4	XY128A00	SPEAKER	8cm JA0868	055730
* 1-5	AAX11080	PLATE,LEG	R	054709
* 1-5	AAX11090	PLATE,LEG	L	054710
* 1-6	AAX11340	FOOT		055583
* 1-7	AAX11370	PAD		054711
* 1-8	AAX10980	WASHER, FILM		055592
* 1-9	AAX10790	PAN HEAD B-TITE SCREW	4x12	056603
* 1-10	AAX10860	BIND HEAD TAPPING SCREW	3x16	021373
* 1-11	AAX10870	BIND HEAD TAPPING SCREW	4x12	021379
* 1-12	AAX10830	BIND HEAD B-TITE SCREW	3x10	048835
* 1-13	AAX11360	WING BOLTS	M4x0.7	057360
* 2-1	AAX14930	REAR PANEL		059548
* 2-2-1	AAX10810	PAN HEAD B-TITE SCREW	3x12 ZC	075293
* 2-2-2	AAX10110	INSULATOR	MICA TO-220	044391
* 2-2-3	AAX10880	HEATSINK		054914
* 2-2-4	AAX11050	CUSHION BUSH	B-24	044543
* 2-2-5	AAX11070	BRACKET, P.C.B.	C A3B1A0	077876
2-2-6	EP600250	BIND HEAD B-TITE SCREW	3x8 ZMC2-Y	075636
2-2-7	XV466A00	IC	LM1875T	055041
* 2-3	AAX11060	BRACKET,POWER SW		054918
* 2-4	AAX11290	MOLD FRONT		054919
* 2-5	AAX10920	MOLD HEATSINK COVER		054920
* 2-6	AAX14920	BUTTON POWER SW		059547
* 2-7	AAX10050	DECO FL FILTER		054922
* 2-8	AAX10780	DECO DISPLAY		054923
* 2-9	AAX10650	SPACER	KGLS-22S	055170
* 2-10	AAX10630	CHASSIS		057186
* 2-11	AAX10620	SHIELD COVER		056884
* 2-12	AAX10120	INSULATOR, POWER SW		056885
* 2-13	AAX10130	CUSHION	8x25x6	056892
△* 2-14	VZ163900	POWER CORD	B	055284
△ 2-14	VZ164000	POWER CORD	G	076128
2-15	CB072750	CORD STOPPER	SR-4N-4	078569
* 2-16	AAX11310	RIVET	M3	080557
2-17	CB069250	BINDING TIE	BK-1	080558
* 2-18	AAX11030	FLAT CABLE	17P 125mm DSP	057116
* 2-19	AAX10830	BIND HEAD B-TITE SCREW	3x10	048835
△* 2-21	XY773A00	TRANSFORMER POWER		059489
* 2-22	AAX10820	FLAT HEAD SCREW	M3x6 ZC	075163
* 2-23	AAX09630	BIND HEAD B-TITE SCREW	3x8@ BL B	075243
2-24	EP600250	BIND HEAD B-TITE SCREW	3x8 ZMC2-Y	075636
* 2-25	AAX10840	BIND HEAD B-TITE SCREW	3x10 BL	075640
* 2-26	AAX10850	BIND HEAD C-TITE SCREW	4x6 ZC	075681
* 2-27	AAX10990	CONNECTOR, FLAT CABLE	13P 92mm AF	055512
* 2-28	AAX11010	CONNECTOR, FLAT CABLE	23P 280mm MAIN	055514
* 2-29	AAX11020	CONNECTOR, FLAT CABLE	9P 330mm WRITER	055515
* 2-30	AAX12940	RIVET	NRP-345	058386
* 3	AAX15150	P.C.B. ASSY	AMP	331416
* 4	AAX15140	P.C.B. ASSY	DSP-FL	331415

* New Parts

Ref. No.	PART NO.	Description	Remarks	Markets
* 200	V5633900	ACCESSORIES		
* 200-1	AAX15160	REMOTE CONTROL	059946	
*	AAX11350	LID	331540	
*	AAX10940	FASTENER TAPE	055593	
		PIN CORD	055701	
		BATTERY		
		2pcs		
		2p 3mx1		
		SUM4,AAA,R03		

* New Parts

AV-S70/NX-SW70

1 ■ SW-AVS70 EXPLODED VIEW

2

3

4

5

6

7

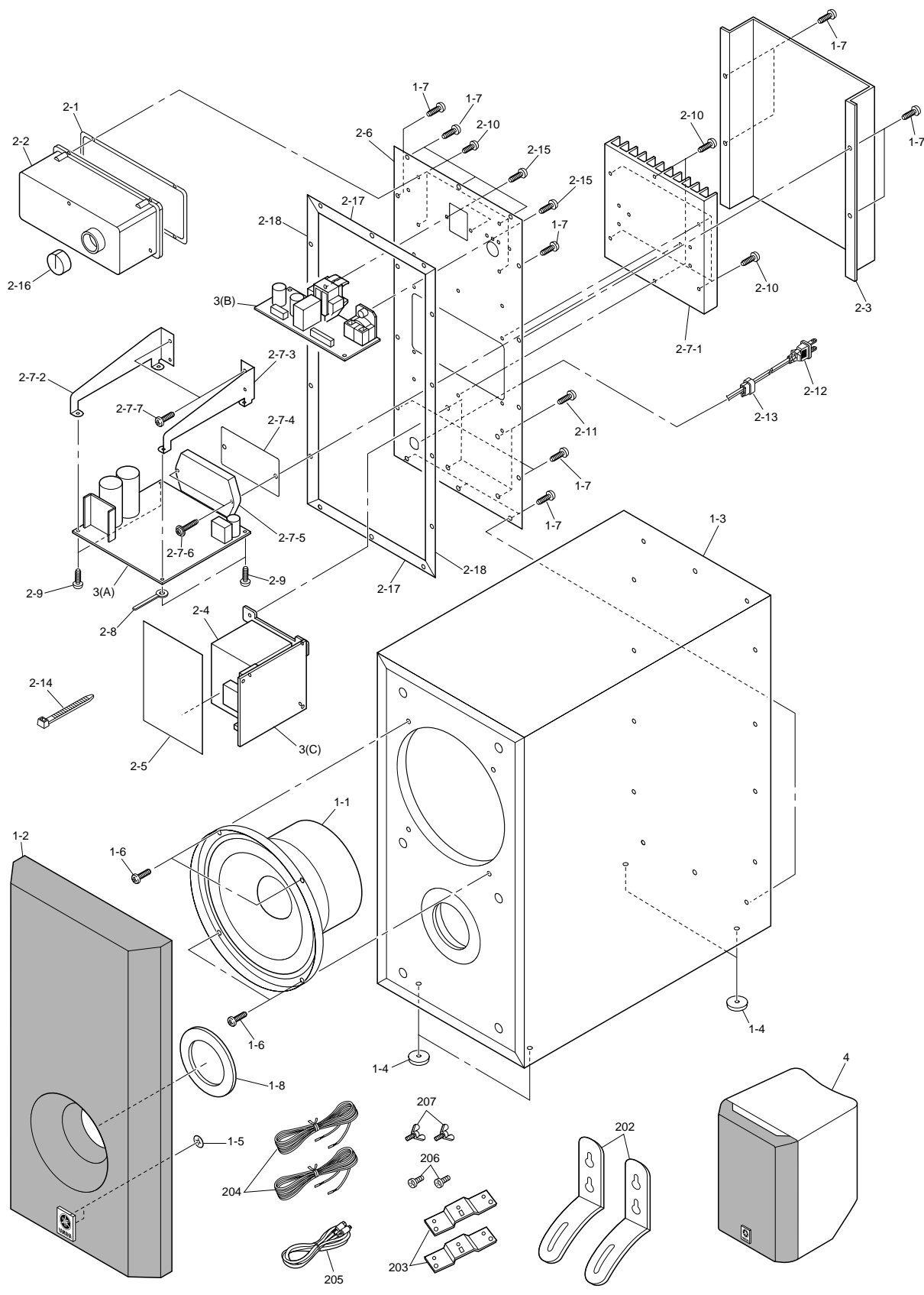

■ SW-AVS70 MECHANICAL PARTS

Ref. No.	PART NO.	Description	Remarks	Markets
* 1- 1	AAX12510	SPEAKER	16cm	055732
* 1- 2	AAX12310	GRILLE ASS'Y		055754
* 1- 3	AAX12040	ENCLOSURE		055038
* 1- 4	AAX12290	FOOT		055357
1- 5	XX701830	NUT		042382
* 1- 6	AAX12130	BIND HEAD TAPPING SCREW	M3.5x16	021404
* 1- 7	AAX12120	BIND HEAD TAPPING SCREW	M4x20	021385
* 1- 8	AAX12930	SEAL		056813
* 2- 1	AAX09340	CUSHION A		053455
* 2- 2	AAX09720	MOLD CASE		053456
* 2- 3	AAX14940	BRACKET GUARD		054956
△ * 2- 4	XY774A00	TRANSFORMER POWER		059533
* 2- 5	AAX12340	INSULATION SHEET		056042
* 2- 6	AAX14950	REAR PANEL		059802
* 2-7-1	AAX12320	HEATSINK	MAIN	054948
* 2-7-2	AAX12010	BRACKET,P.C.B.	L	054954
* 2-7-3	AAX12020	BRACKET,P.C.B.	R	054955
* 2-7-4	AAX12030	INSULATOR	MICA	054958
* 2-7-5	AAX11970	IC	STK408-040E	049670 (IC109)
* 2-7-6	AAX12380	PAN HEAD B-TITE SCREW	3x20 BL	055430
* 2-7-7	AAX12090	BIND HEAD B-TITE SCREW	3x12 BL	075642
* 2- 8	AAX12160	BRACKET	CLIP L80 A	078004
* 2- 9	AAX12080	BIND HEAD B-TITE SCREW	3x6 ZC	075633
* 2-10	AAX12090	BIND HEAD B-TITE SCREW	3x12 BL	075642
* 2-11	AAX12100	BIND HEAD B-TITE SCREW	4x10 BL	075659
△ * 2-12	VZ163900	POWER CORD	B	055284
△ 2-12	VZ164000	POWER CORD	G	076128
* 2-13	AAX12230	CUSHION STOPPER	SR-4	078519
2-14	CB069250	BINDING TIE	BK-1	080558
* 2-15	AAX12110	BIND HEAD B-TITE SCREW	3x10 BL BO	084772
* 2-16	AAX09370	CUSHION BUSH		084849
* 2-17	AAX12910	SEAL		055433
* 2-18	AAX12920	SEAL		058018
* 3	AAX12780	P.C.B. ASSY	AMP	057955
* 4	AAX12520	SPEAKER SYSTEM	1pc	055719S
		ACCESSORIES		
* 202	AAX12600	WALL BRACKET	2pcs	012941
* 203	AAX12140	BRACKET	2pcs	012933
* 204	AAX12220	CORD	15mx2	055751
* 205	AAX11960	DIN CORD	8P 3mx1	055905
* 206	AAX12390	PAN HEAD SCREW-SEMS	M4x8	017957
* 207	AAX11360	WING BOLTS	M4x0.7	057360

* New Parts

AV-S70/NX-SW70

1

REMOTE CONTROL TRANSMITTER

■ SCHEMATIC DIAGRAM

2

3

4

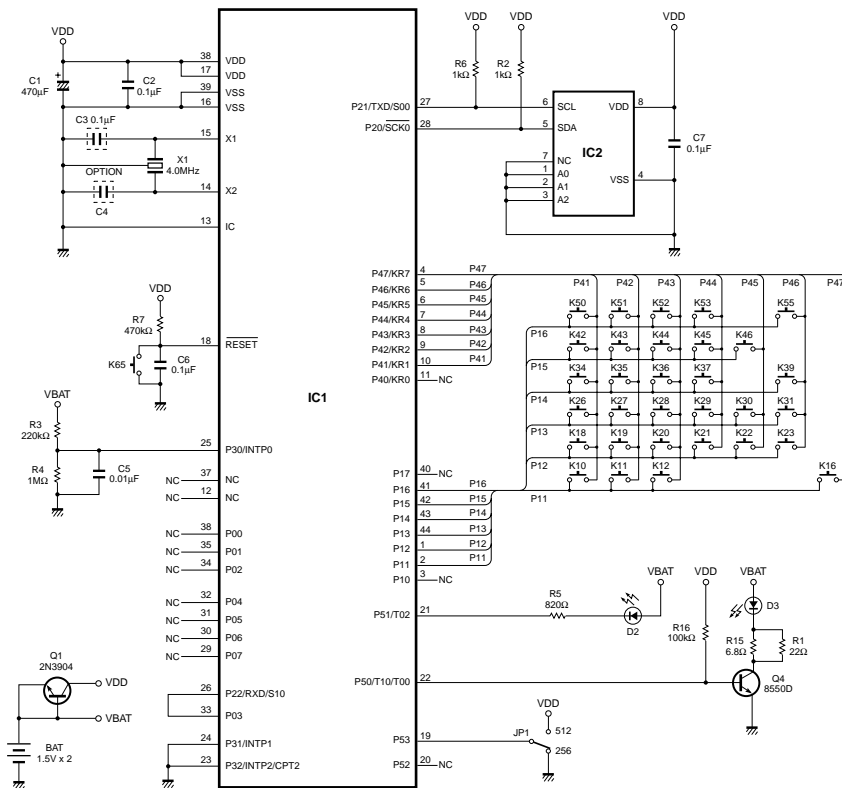

5

6

7

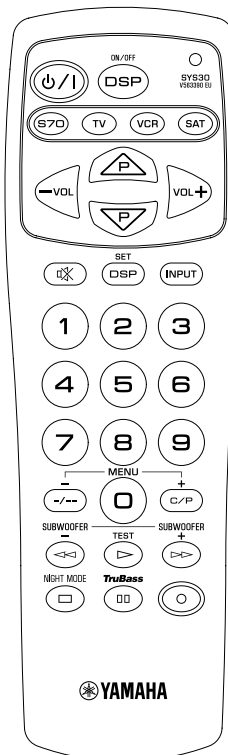

Initial code of YAMAHA

Key No.	FUNCTION	CUSTOM (HEX)	DATA (HEX)
10	🔊	78	9C
11	DSP SET	78	51
12	INPUT	78	5E
16	TruBass	78	8B
18	VOL -	78	1F
19	⬇️ P ⬆️	—	—
20	⬆️ P ⬇️	—	—
21	VOL +	78	1E
22	🔊/I	78	0F
23	TEST	78	5F
26	DSP ON/OFF	78	50
27	S70	—	—
28	VCR	—	—
29	SAT	—	—
30	TV	—	—
31	0	—	—
34	1 (TEST MODE only)	78	11
35	4 (TEST MODE only)	78	14
36	7 (TEST MODE only)	78	17
37	MENU +	78	9E
39	SUBWOOFER -	78	4D
42	2 (TEST MODE only)	78	12
43	5 (TEST MODE only)	78	15
44	8 (TEST MODE only)	78	18
45	MENU	78	9D
46	NIGHT MODE	78	8A
50	3 (TEST MODE only)	78	13
51	6 (TEST MODE only)	78	16
52	9 (TEST MODE only)	78	19
53	MENU -	78	9F
55	SUBWOOFER +	78	4C

Parts List for Carbon Resistors

Value	1/4W Type Part No.	1/6W Type Part No.	Value	1/4W Type Part No.	1/6W Type Part No.
1.0 Ω	HJ35 3100	HF85 3100	10 kΩ	HF45 7100	HF45 7100
1.8 Ω	HJ35 3180	*	11 kΩ	HF45 7110	HF45 7110
2.2 Ω	HJ35 3220	HF85 3220	12 kΩ	HJ35 7120	HF85 7120
3.3 Ω	HJ35 3330	HF85 3330	13 kΩ	HF45 7130	HF45 7130
4.7 Ω	HJ35 3470	HF85 3470	15 kΩ	HF45 7150	HF45 7150
5.6 Ω	HJ35 3560	HF85 3560	18 kΩ	HF45 7180	HF45 7180
10 Ω	HF45 4100	HF45 4100	22 kΩ	HF45 7220	HF45 7220
15 Ω	HJ35 4150	HF85 4150	24 kΩ	HF45 7240	HF45 7240
22 Ω	HF45 4220	HF45 4220	27 kΩ	HJ35 7270	HF85 7270
27 Ω	HJ35 4270	HF85 4270	30 kΩ	HF45 7300	HF45 7300
33 Ω	HF45 4330	HF45 4330	33 kΩ	HF45 7330	HF45 7330
39 Ω	HJ35 4470	HF85 4390	36 kΩ	HF45 7360	HF45 7360
47 Ω	HF45 4470	HF45 4470	39 kΩ	HF45 7390	HF45 7390
56 Ω	HF45 4560	HF45 4560	47 kΩ	HF45 7470	HF45 7470
68 Ω	HF45 4680	HF45 4680	51 kΩ	HF45 7510	HF45 7510
75 Ω	HF45 4750	HF45 4750	56 kΩ	HF45 7560	HF45 7560
82 Ω	HF45 4820	HF45 4820	62 kΩ	HF45 7620	HF45 7620
91 Ω	HF45 4910	HF45 4910	68 kΩ	HF45 7680	HF45 7680
100 Ω	HF45 5100	HF45 5100	82 kΩ	HF45 7820	HF45 7820
110 Ω	HJ35 5110	HF85 5110	91 kΩ	HF45 7910	HF45 7910
120 Ω	HF45 5120	HF45 5120	100 kΩ	HF45 8100	HF45 8100
150 Ω	HF45 5150	HF45 5150	110 kΩ	HF45 8110	HF45 8110
160 Ω	HJ35 5160	*	120 kΩ	HF45 8120	HF45 8120
180 Ω	HF45 5180	HF45 5180	150 kΩ	HF45 8150	HF45 8150
200 Ω	HF45 5200	HF45 5200	180 kΩ	HF45 8180	HF45 8180
220 Ω	HF45 5220	HF45 5220	220 kΩ	HJ35 8220	HF85 8220
270 Ω	HF45 5270	HF45 5270	270 kΩ	HF45 8270	HF45 8270
330 Ω	HF45 5330	HF45 5330	300 kΩ	HF45 8300	HF45 8300
390 Ω	HF45 5390	HF45 5390	330 kΩ	HF45 8330	HF45 8330
430 Ω	HF45 5430	HF45 5430	390 kΩ	HJ35 8390	HF85 8390
470 Ω	HF45 5470	HF45 5470	470 kΩ	HF45 8470	HF45 8470
510 Ω	HF45 5510	HF45 5510	560 kΩ	HJ35 8560	HF85 8560
560 Ω	HF45 5560	HF45 5560	680 kΩ	HJ35 8680	HF85 8680
680 Ω	HF45 5680	HF45 5680	820 kΩ	HJ35 8820	HF85 8820
820 Ω	HF45 5820	HF45 5820	1.0 MΩ	HF45 9100	HF45 9100
910 Ω	HF45 5910	HF45 5910	1.2 MΩ	HJ35 9120	*
1.0 kΩ	HF45 6100	HF45 6100	1.5 MΩ	HJ35 9150	HF85 9150
1.2 kΩ	HF45 6120	HF45 6120	1.8 MΩ	HJ35 9180	HF85 9180
1.5 kΩ	HF45 6150	HF45 6150	2.2 MΩ	HJ35 9220	HF85 9220
1.8 kΩ	HF45 6180	HF45 6180	3.3 MΩ	HJ35 9330	HF85 9330
2.0 kΩ	HJ35 6200	HF85 6200	3.9 MΩ	HJ35 9390	*
2.2 kΩ	HF45 6220	HF45 6220	4.7 MΩ	HJ35 9470	HF85 9470
2.4 kΩ	HJ35 6240	HF85 6240			
2.7 kΩ	HF45 6270	HF45 6270			
3.0 kΩ	HF45 6300	HF45 6300			
3.3 kΩ	HF45 6330	HF45 6330			
3.6 kΩ	HJ35 6360	HF85 6360			
3.9 kΩ	HF45 6390	HF45 6390			
4.7 kΩ	HF45 6470	HF45 6470			
5.1 kΩ	HF45 6510	HF45 6510			
5.6 kΩ	HF45 6560	HF45 6560			
6.8 kΩ	HF45 6680	HF45 6680			
8.2 kΩ	HF45 6820	HF45 6820			
9.1 kΩ	HF45 6910	HF45 6910			
				<p>1/4W Type HJ35 ○○○○</p> <p>1/6W Type HF85 ○○○○</p>	