

HOME THEATER SYSTEM

AV-S77

SERVICE MANUAL

The AV-S77 is composed of the AV-S77C, the NX-SW77 and the NX-S77E.

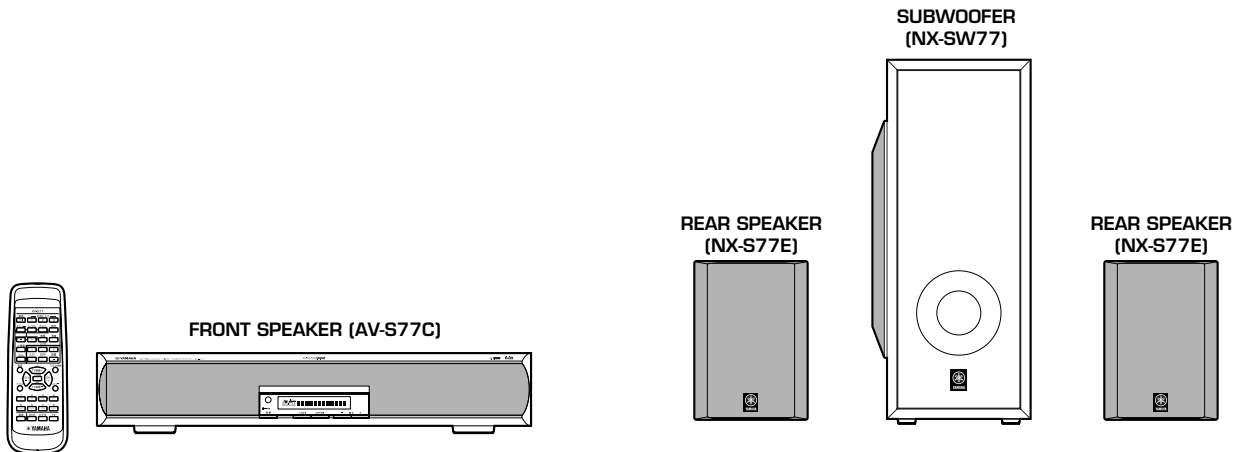

IMPORTANT NOTICE

This manual has been provided for the use of authorized YAMAHA Retailers and their service personnel. It has been assumed that basic service procedures inherent to the industry, and more specifically YAMAHA Products, are already known and understood by the users, and have therefore not been restated.

WARNING: Failure to follow appropriate service and safety procedures when servicing this product may result in personal injury, destruction of expensive components, and failure of the product to perform as specified. For these reasons, we advise all YAMAHA product owners that any service required should be performed by an authorized YAMAHA Retailer or the appointed service representative.

IMPORTANT: The presentation or sale of this manual to any individual or firm does not constitute authorization, certification or recognition of any applicable technical capabilities, or establish a principle-agent relationship of any form.

The data provided is believed to be accurate and applicable to the unit(s) indicated on the cover. The research, engineering, and service departments of YAMAHA are continually striving to improve YAMAHA products. Modifications are, therefore, inevitable and specifications are subject to change without notice or obligation to retrofit. Should any discrepancy appear to exist, please contact the distributor's Service Division.

WARNING: Static discharges can destroy expensive components. Discharge any static electricity your body may have accumulated by grounding yourself to the ground buss in the unit (heavy gauge black wires connect to this buss).

IMPORTANT: Turn the unit OFF during disassembly and part replacement. Recheck all work before you apply power to the unit.

CONTENTS

TO SERVICE PERSONNEL	1	IC DATA	17~23
FRONT/REAR PANEL	1~2	DISPLAY DATA	24
SPECIFICATIONS	3~4	BLOCK DIAGRAM	25~29
INTERNAL VIEW (AV-S77C)	4	PRINTED CIRCUIT BOARD	30~41
DISASSEMBLY PROCEDURES	5~6	SCHEMATIC DIAGRAM	42~46
P.C.B. OPERATION CHECK	6	PARTS LIST	47~59
TEST PROGRAM MODE	7~9	REMOTE CONTROL TRANSMITTER	60
DSP DIAG MODE (Self-diagnosis)	9~16		



このサービスマニュアルは、エコマーク認定の再生紙を使用しています。
This Service Manual uses recycled paper.



■ TO SERVICE PERSONNEL

1. Critical Components Information

Components having special characteristics are marked  and must be replaced with parts having specifications equal to those originally installed.

2. Leakage Current Measurement (For 120V Models Only)

When service has been completed, it is imperative to verify that all exposed conductive surfaces are properly insulated from supply circuits.

- Meter impedance should be equivalent to 1500 ohm shunted by 0.15μF.
- Leakage current must not exceed 0.5mA.
- Be sure to test for leakage with the AC plug in both polarities.

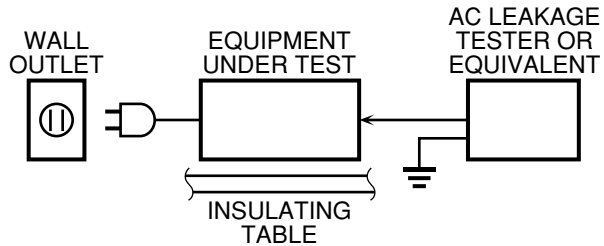

WARNING: CHEMICAL CONTENT NOTICE!

The solder used in the production of this product contains LEAD. In addition, other electrical/electronic and /or plastic (where applicable) components may also contain traces of chemicals found by the California Health and Welfare Agency (and possibly other entities) to cause cancer and/or birth defects or other reproductive harm.

DO NOT PLACE SOLDER, ELECTRICAL/ELECTRONIC OR PLASTIC COMPONENTS IN YOUR MOUTH FOR ANY REASON WHATSOEVER!

Avoid prolonged, unprotected contact between solder and your skin! When soldering, do not inhale solder fumes or expose eyes to solder/flux vapor!

If you come in contact with solder or components located inside the enclosure of this product, wash your hands before handling food.

■ FRONT/REAR PANEL

▼ AV-S77C

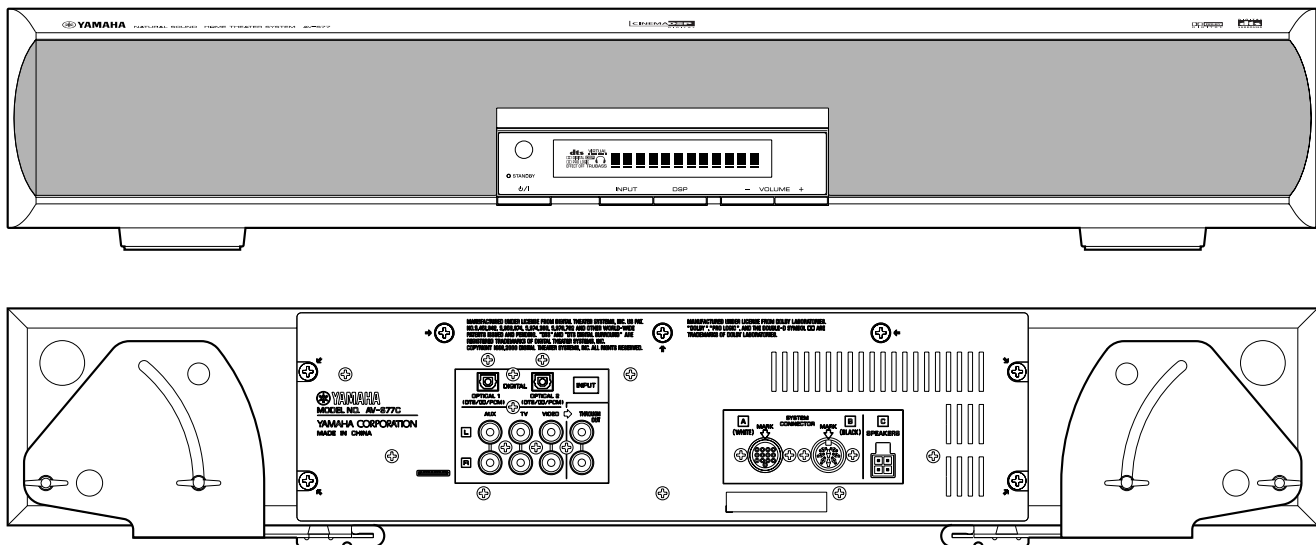

▼ REMOTE CONTROL TRANSMITTER

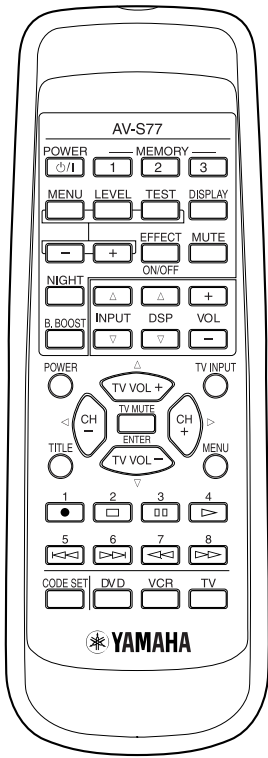

▼ NX-S77E

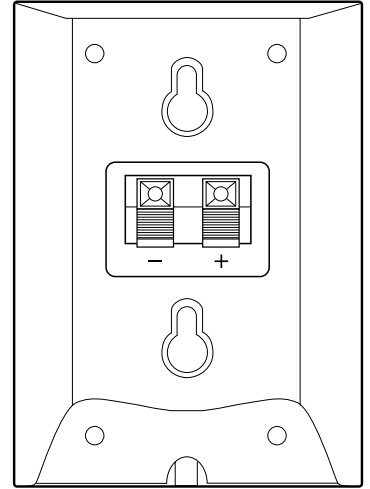
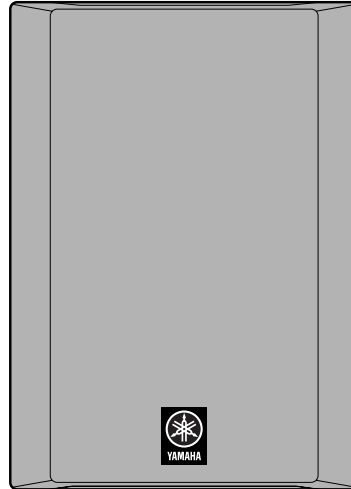

▼ NX-SW77

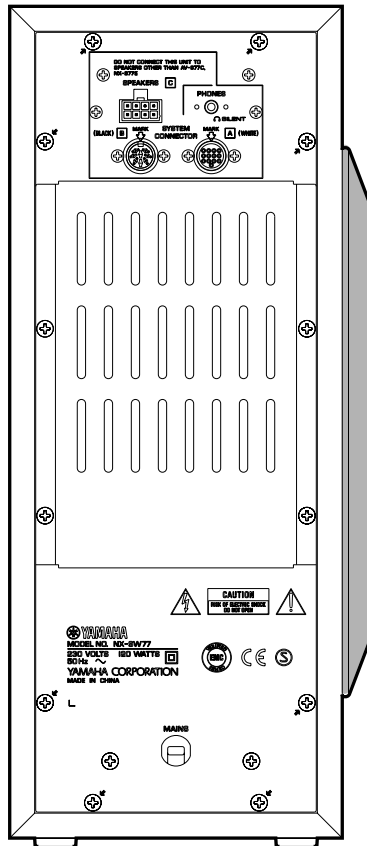
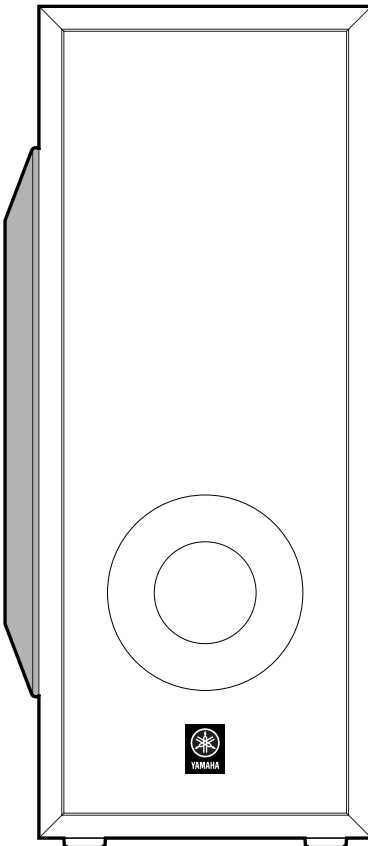

■ SPECIFICATIONS

AMPLIFIER SECTION

Maximum Output Power

Front (1kHz, 10 % THD, 6Ω)	25W + 25W
Rear (1kHz, 10 % THD, 6Ω)	25W + 25W
Subwoofer (100Hz, 10 % THD, 5Ω)	50W

Signal to Noise Ratio (IHF-A, AUX) 95dB

Total Harmonic Distortion (AUX, 1kHz, 12.5W/6Ω) 0.05%

Input Sensitivity / Impedance (AUX) 200mV / 50kΩ

FRONT SPEAKER SECTION (AV-S77C)

Type	Bass Reflex
Driver	8cm Cone x 2, Magnetic Shielding Type
Nominal Input Power	30W
Impedance	6Ω
Frequency Response	120Hz ~ 20kHz

REAR SPEAKER SECTION (NX-S77E)

Type	Acoustic Suspension
Driver	8cm Cone, Magnetic Shielding Type
Nominal Input Power	30W
Impedance	6Ω
Frequency Response	140Hz ~ 20kHz

SUBWOOFER SECTION (NX-SW77)

Type	Advanced YAMAHA Active Servo Technology
Driver	16cm Cone, Magnetic Shielding Type
Frequency Response	30Hz ~ 200Hz

GENERAL

Power Supply

B, G models AC 230V 50Hz

Power Consumption 120W

Standby Power Consumption about 1W

Max. Dimensions (W x H x D)

AV-S77C	600 x 110 x 220 mm (23-5/8" x 4-5/16" x 8-11/16")
NX-SW77	176 x 405 x 433 mm (6-15/16" x 16" x 17-1/16")
NX-S77E	100 x 140 x 112 mm (3-15/16" x 5-1/2" x 4-3/8")

Weight

AV-S77C	5.0kg (11 lbs.)
NX-SW77	11.0kg (24 lbs. 4 oz.)
NX-S77E	0.8kg (1 lbs. 12 oz.)

Accessories

Remote Controller, Batteries (R6P) x 2, Audio Connection Cord (2 pin, 3 m) x 1, System Connector Cable (8 pin, 3m) x 1, System Connector Cable (13 pin, 3m) x 1, Speaker Cords (Rear: 15m, Front: 3m) x 1, Velcro Strips x 2 sets, Speaker Mounting brackets (Type A) x 2, Speaker Mounting brackets (Type B) x 2, Screw x 2, Wing Nuts x 2, Connection Guide

* Specifications are subject to change without notice due to product improvements.

B British model
G European model



Manufactured under license from Dolby Laboratories.

"Dolby", "Pro Logic" and the double-D symbol are trademarks of Dolby Laboratories.



"DTS" and "DTS Digital Surround" are registered trademarks of Digital Theater Systems, Inc.

▼ AV-S77C Dimensions

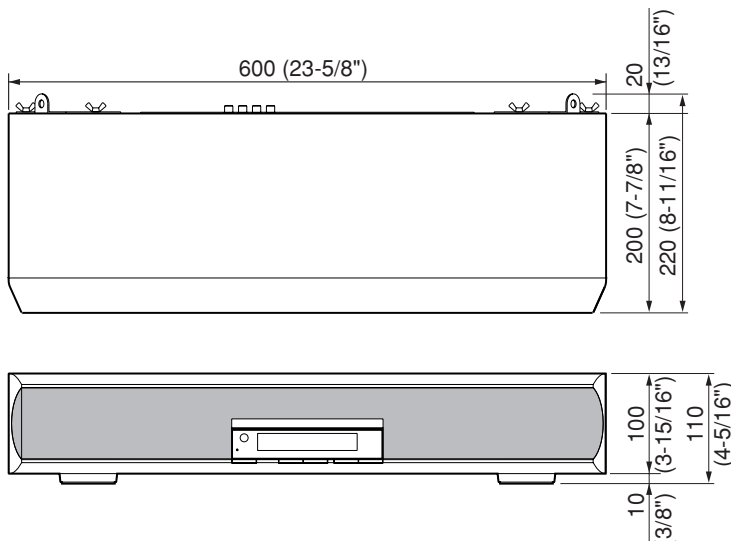

Unit: mm (inch)

▼ NX-S77E Dimensions

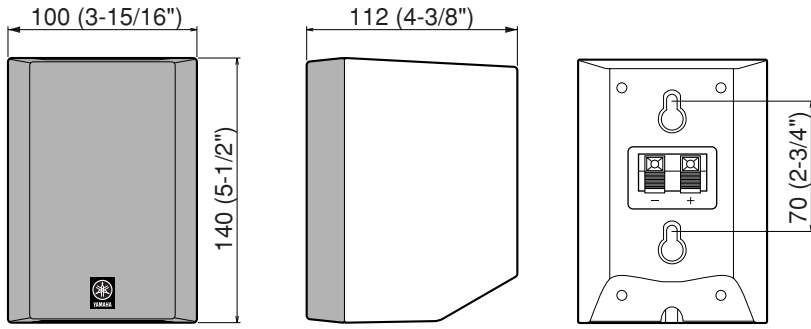

Unit: mm (inch)

▼ NX-SW77 Dimensions

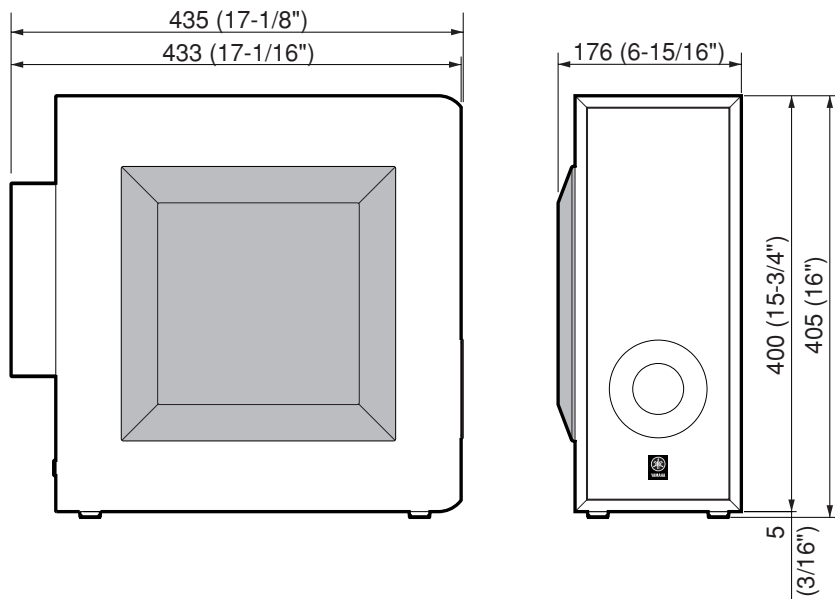

Unit: mm (inch)

■ INTERNAL VIEW (AV-S77C)

- ① MAIN P.C.B.
- ② DSP P.C.B.
- ③ OPERATION P.C.B.

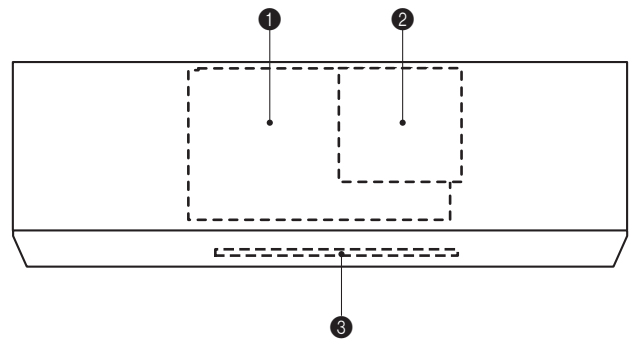

■ DISASSEMBLY PROCEDURES

(Remove parts in the order as numbered.)

Disconnect the power cord from the AC outlet.

AV-S77C Disassembly procedures

1. Removal of Grille Ass'y

- a. Insert a flat tip screwdriver or the like from the bottom of the Grille Assembly.
- b. Push up the Grille Assembly with the screwdriver gradually until it can be removed from the main unit. (Fig. 1).

* **The Grille Assembly is fixed securely at 8 dowels. When removing it, use care not to cause a scratch or any damage to the main unit. When reinstalling it, apply quick-drying type bond to the dowels of the Grille Assembly and fit it in place securely. (If it is only pushed in, it will come off easily.)**

- c. Remove 8 screws (①). The OPERATION P.C.B. can then be removed from the Grille Assembly. (Fig. 1)

2. Removal of Amplifier Unit

- a. Remove 6 screws (②). (fig. 1)
- b. Remove 7 screws (③) and take out the Amplifier Unit and OPERATION P.C.B. in the arrow direction. (Fig. 2)
- c. Remove the connectors CN304 and CN305. (Fig. 3)

3. Removal of DSP Unit

- a. Remove the connectors CB2 and CB3. (Fig. 3)
- b. Remove 8 screws (④). The DSP Unit can then be removed. (Fig. 3)

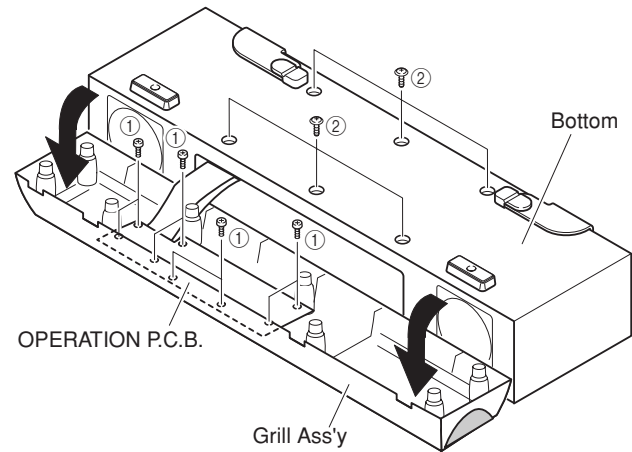

Fig. 1

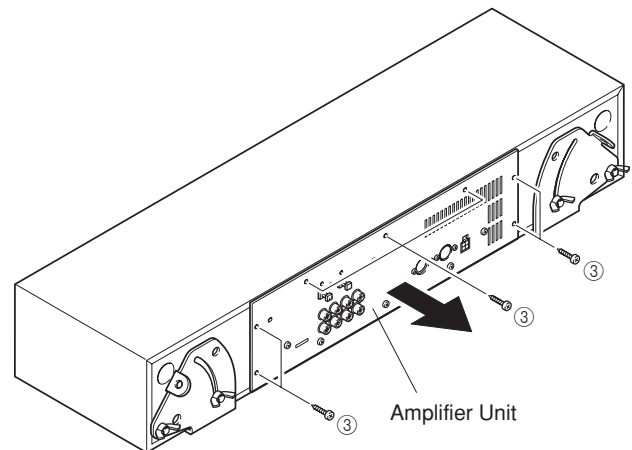

Fig. 2

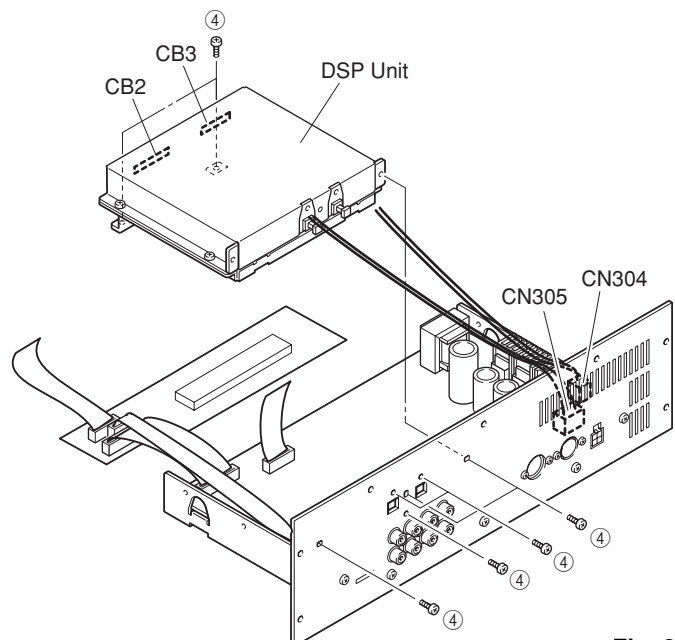

Fig. 3

NX-SW77 Disassembly procedures

1. Removal of Grille Ass'y

- Push up the Grille Assembly with a flat tip screwdriver or the like inserted from the bottom. (Fig. 4).
- Keep pushing up the Grille Assembly gradually until it can be removed.

* **The Grille Assembly is fixed securely at 6 dowels. When removing it, use care not to cause a scratch or any damage to the main unit. When reinstalling it, apply quick-drying type bond to the dowels of the Grille Assembly and fit it in place securely. (If it is only pushed in, it will come off easily.)**

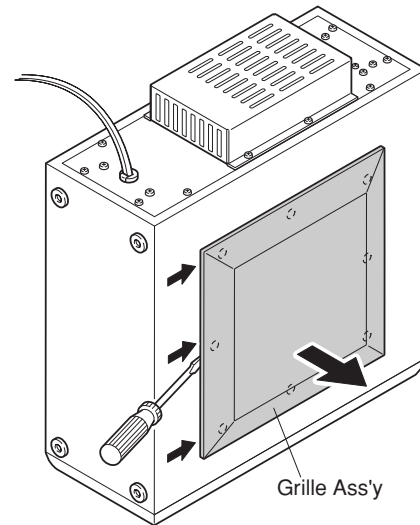

Fig. 4

2. Removal of Amplifier Unit

Remove 12 screws (⑤) and then remove the Amplifier Unit. (Fig. 5)

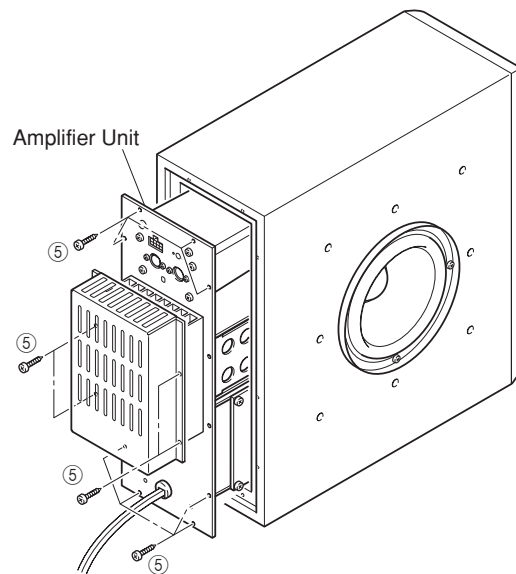
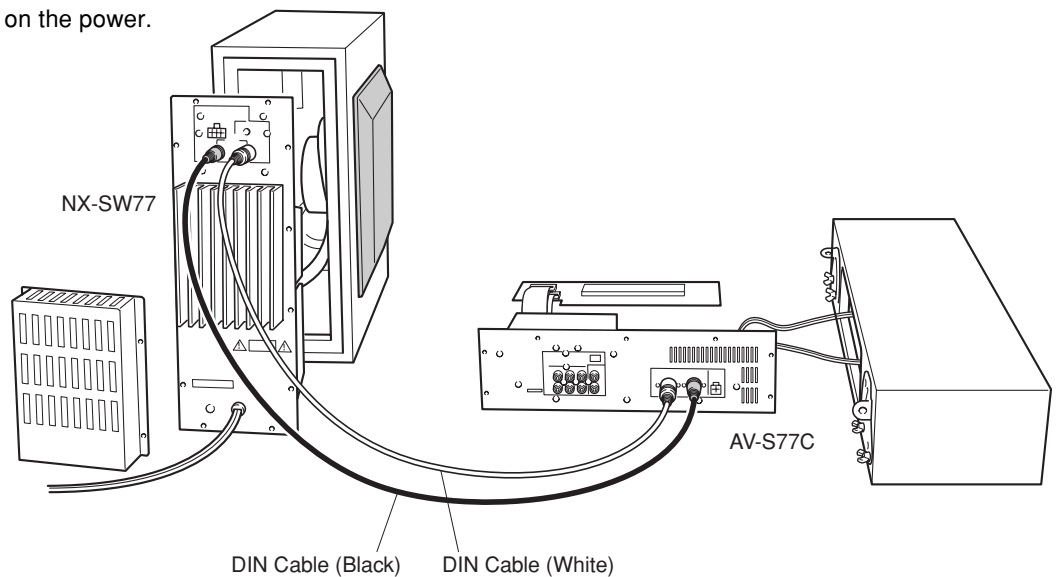

Fig. 5

■ P.C.B. OPERATION CHECK

- Remove the Amplifier Unit, referring to Disassembly procedures described above.
- Remove each P.C.B as required.
- Connect all the connectors between P.C.B.s as connected originally.
- Using 2 DIN cables, connect the AV-S77C and the NX-SW77.
- Connect the power cord of the NX-SW77 to the AC power outlet and turn on the power.



■ TEST PROGRAM MODE

1. Procedure for starting Test Program

With the power plug disconnected from the outlet, reconnect it to the outlet while pressing the [VOLUME] key and the [DSP] key simultaneously, and the Test Program will be activated.

When the Test Program is activated, "01 DEST-Ex" is displayed.

2. Procedure for selecting and executing Test Program

Using the [VOLUME +] (UP) key and the [Volume -] (DOWN) key, select the Test Program and then press the INPUT key to execute it.

3. Procedure for canceling Test Program

There are two methods for cancellation.

- a. Turn off the power by pressing the [POWER] key of the main unit or the remote controller.
- b. Select the Test Program "01 DEST-Ex" and press the [INPUT] key for execution. (The normal mode will be restored.)

4. Details of the Test Program function

Display	Function
01 DEST-B,G1	Destination display/ test program end Destination display J: J _a J (Japanese) B, G1 B, G models
02 Fact. Test	Factory test mode This test mode is used for factory inspection before shipping and is not usually used. If the test program has been executed, it is not possible to shift to another test program. In such case, cancel the test program.
03 FL+CLEAR	FL display segments all light up / BACKUP RAM CLEAR 1 st time: FL display segments all light up and standby LED lights up. 2 nd time: RAM CLEAR is executed (RAM CLEAR OK on display) * State before shipped out of the factory preset.
04 FL CHECK	FL display light-up check 1 st time: FL display segments all light up and standby LED lights up. 2 nd time: Even number segments and digits light up. 3 rd time: Odd number segments and digits light up.

1st time



2nd time

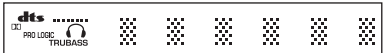

3rd time



Display	Function
05 DSP Diag	The DSP DIAG (self-diagnosis) mode is activated. (Refer to next page for the details.)
06 Ver-1.02	Microprocessor version / date display Example of microprocessor display 05 Ver-1.02 Example of microprocessor date display 05 '01.06.07 What is displayed varies depending on the microprocessor software.
07 SUM[39ba]	Check sum calculation display / re-calculation
08 ROM Check	Don't use this mode (item). (Its correct operation is not available.)
09 PrCan-OFF	All protection cancellation function ON/OFF *1
10 Pr! P_S_	Protection operation history display / clear P: Power circuit voltage S: NX-SW77 side _: Normal x: Abnormal
11 RemoCorrR	ROM collection (EEPROM) remote control data reception / data write This test mode is not usually used.
12 COR-Clear	ROM collection (EEPROM) data clear / clear start Display is provided only when there is data in the ROM collection area of EEPROM 1 st time: Data clear confirmation (Clear-ON? displayed) 2 nd time: Data clear execution (Clear=OK! displayed) After "Clear-ON?" is displayed, do not use INPUT key for execution (because the program contents will be erased). Using [VOLUME +] (UP) key and [VOLUME -] (DOWN) key, select another test program. * The IC for ROM collection has a role to help the microprocessor be upgraded. If the written data is cleared, the old version will be restored.

*1 CAUTION:

Using this product with the protection function cancelled may cause damage to itself. Use special care for this point when using this mode.

Display	Function
13 Cors- St.	<p>ROM collection (EEPROM) check sum calculation/calculation start</p> <p>This message is displayed only when data exists in the ROM correction area of EEPROM.</p> <p>Example of display 13 Cors-288b</p> <p>* The ROM collection (EEPROM) is utilized to cope with the data area for backup and microprocessor bugs partially. The backup memory for the sound field or the like will be retained semi-permanently even when the plug is disconnected. No data is written in the parts mounted on the product as single units.</p>

■ DSP DIAG MODE (Self-diagnosis)

1. Procedure for starting DSP DIAG

Referring to TEST PROGRAM MODE in the previous section, select/execute "05 DSP Diag".

When "05 DSP Diag" is executed, the current input name is displayed followed by "Push DSP Key". (The DSP indicator keeps blinking.)

When the [DSP] key is pressed next, "Analog Thr." of the main menu is displayed followed by "A.T.M. Bypass" of the sub-menu.

2. Procedure for selecting Main menu and Sub-menu

To change the main menu item, keep pressing the [DSP] key and to change the sub-menu item, press the [DSP] key intermittently.

No.	Main menu	(Display)	Sub-menu	(Display)
1	Analog through	Analog Thr.	MAIN BYPASS	A.T.M. Bypass
			DSP 0dB	A.T. DSP 0dB
2	DSP through	Dsp Through	YSS908-SRAM	DspT.908SRAM
			YS908	DspT.YSS908
			DSP FULL BIT	DspT.FullBit
3	AC-3/dts through	AC-3/dts Thr.	*1	Analo2/0
4	Pro logic	Pro Logic	CENTER LARGE	ProL.CenterL
			EFFECT OFF	ProL.Eff.Off
5	Speakers set	Speakers Set	MAIN : SMALL 0dB	Sp.MainS 0dB
			MAIN : LARGE 0dB	Sp.MainL 0dB
			LFE/BASS : MAIN	
			CENTER : NONE	Sp.Lfe:M C:N
			LFE/BASS : MAIN	Sp.LfeBass:M
			LFE/BASS : SWFR	Sp.Lfe:Swfr
			CENTER : NONE	Sp.Cent:None
6	Effect off	Effect Off	CENTER : SMALL	
			REAR : SMALL	Sp.Ce:S Re:S
7	Manual test	Manual Test	EFFECT OFF	Effect Off
			ALL	M.Test All
			MAIN L	M.Test Left
			CENTER	M.TestCenter
			MAIN R	M.Test Right
			REAR R	M.Test RearR
			REAR L	M.Test RearL
LFE	M.Test Lfe			

*1 FL display of AC-3/dts Through

A combination of the sampling frequency and the number of channels is displayed.

Example: "AC-3 32k 2/0"

AC3/dts	Sampling frequency		Number of channels (Front/Rear)	
AC3	Analog	Analog	1+1	1+1
dts	32kHz	32k	1/0	1/0
-	44.1kHz	44.1k	2/0	2/0
-	48kHz	48k	3/0	3/0
-	-	-	2/1	2/1
-	-	-	3/1	3/1
-	-	-	2/2	2/2
-	-	-	3/2 5.1ch	3/2
-	-	-	7.1 (DTS)	7.1

3. Procedure for canceling DIAG

Turn off the power by pressing the [POWER] key of the main unit or the remote controller.

Details of DIAG menu

1. Analog Through

The input is fixed to use the analog (A/D) and has 2 sub-menu items.

MAIN BYPASS

The main L/R signal is output through the analog bypass without passing the DSP section.

The main L/R signal passing through the DSP is output through C/SW and RL/RR.

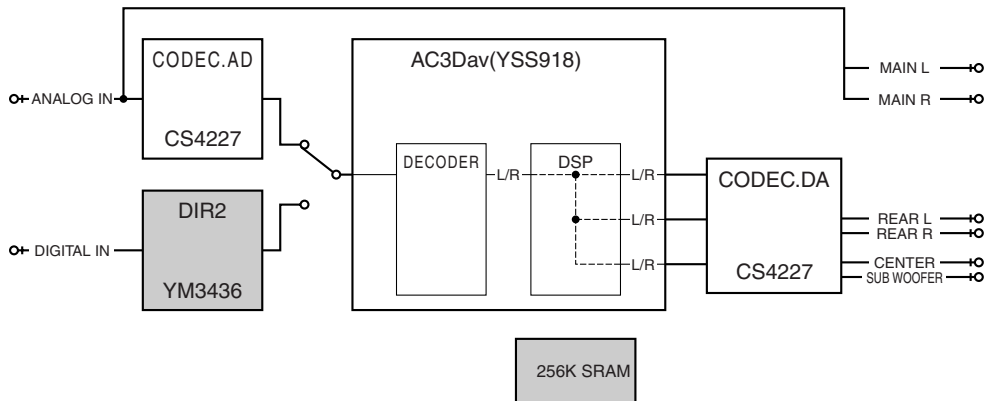

AUX IN : - 20dBV, Both ch
 VOLUME : MAX

CN301 (Page 31, G3)
 MAIN L (1kHz) : - 20dBV
 MAIN R (1kHz) : - 20dBV
 SUBWOOFER (30Hz) : - 34dBV
 REAR L (1kHz) : - 26dBV
 REAR R (1kHz) : - 26dBV
 CENTER (1kHz) : < - 45dBV

 The shaded square means that the element included in it does not operate.

DSP 0dB

The main L/R, C/SW, RL/RR signals pass through the DSP section.

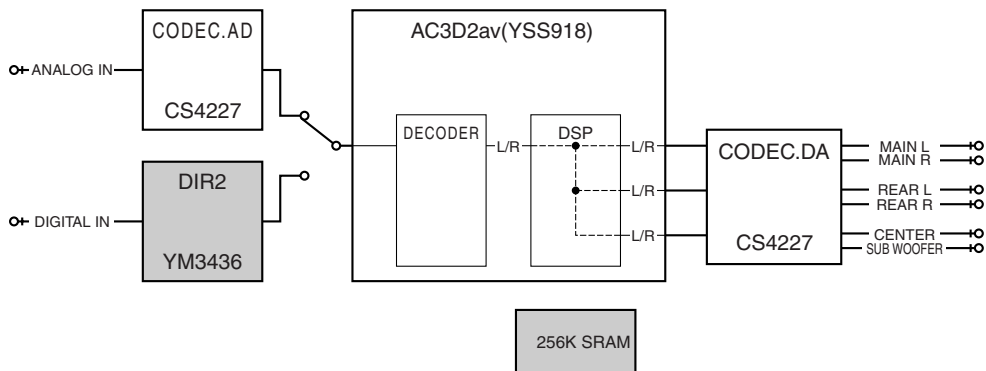

AUX IN : - 20dBV, Both ch
 VOLUME : MAX

CN301 (Page 31, G3)
 MAIN L (1kHz) : - 20dBV
 MAIN R (1kHz) : - 20dBV
 SUBWOOFER (30Hz) : - 34dBV
 REAR L (1kHz) : - 26dBV
 REAR R (1kHz) : - 26dBV
 CENTER (1kHz) : < - 45dBV

 The shaded square means that the element included in it does not operate.

2. DSP Through

In the DIGITAL input mode, AC3/PCM AUDIO signal is automatically identified. There are 3 sub-menu items.

YSS918-SRAM

The main L/R signal is sent through AC3Dav into DSP. After passing through SRAM, the main L/R signal is output through L+R and C/SW and RL/RR signals through (L+R)/2.

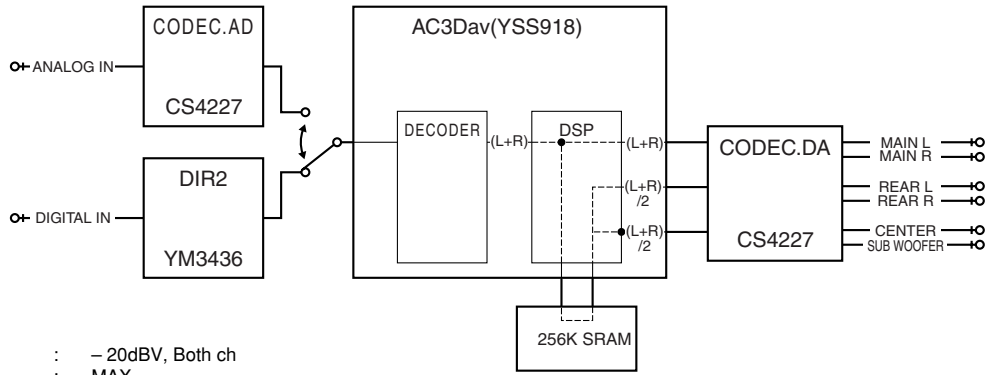

AUX IN : -20dBV, Both ch
 VOLUME : MAX

CN301 (Page 31, G3)

MAIN L (1kHz) : -20dBV
 MAIN R (1kHz) : -20dBV
 SUBWOOFER (30Hz) : -34dBV
 REAR L (1kHz) : -26dBV
 REAR R (1kHz) : -26dBV
 CENTER (1kHz) : < -45dBV

YSS918

The main L/R signal is sent through AC3D2av into DSP. The main L/R signal is output through L+R and C/SW and RL/RR signals through (L+R)/2.

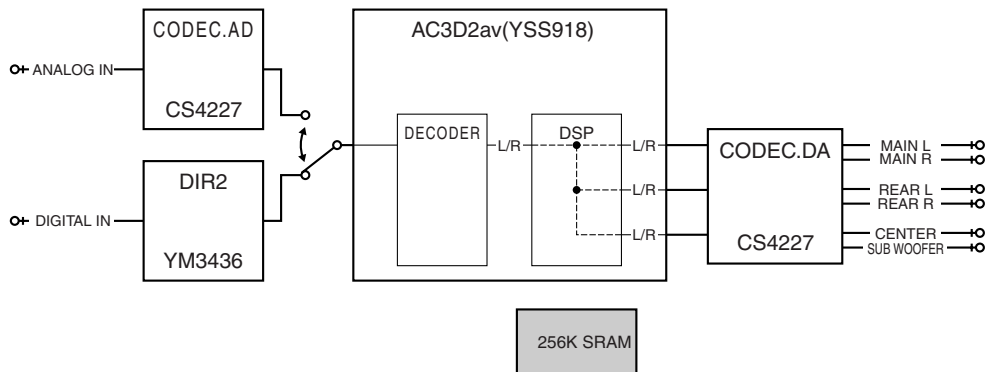

AUX IN : -20dBV, Both ch
 VOLUME : MAX

CN301 (Page 31, G3)

MAIN L (1kHz) : -20dBV
 MAIN R (1kHz) : -20dBV
 SUBWOOFER (30Hz) : -34dBV
 REAR L (1kHz) : -26dBV
 REAR R (1kHz) : -26dBV
 CENTER (1kHz) : < -45dBV

 The shaded square means that the element included in it does not operate.

DSP FULL BIT

The main L/R is input through AC3Dav to DSP and then output through all channels. The same applies as "YSS918" except that the digital data is output in full bit at D/A.

AUX IN : - 20dBV, Both ch
 VOLUME : MAX

CN301 (Page 31, G3)
 MAIN L (1kHz) : - 11dBV
 MAIN R (1kHz) : - 11dBV
 SUBWOOFER (30Hz) : - 13dBV
 REAR L (1kHz) : - 17dBV
 REAR R (1kHz) : - 17dBV
 CENTER (1kHz) : <- 45dBV

3. AC-3/dts Through

Only the signal of the digital system is input. The AC3 signal is decoded and reproduced according to the input source.

The AC-3 signal in each channel is AC-3 decoded and output through AC3Dav. The combined status information of the sampling frequency and the number of channels of the AC3 signal appears on the FI display.

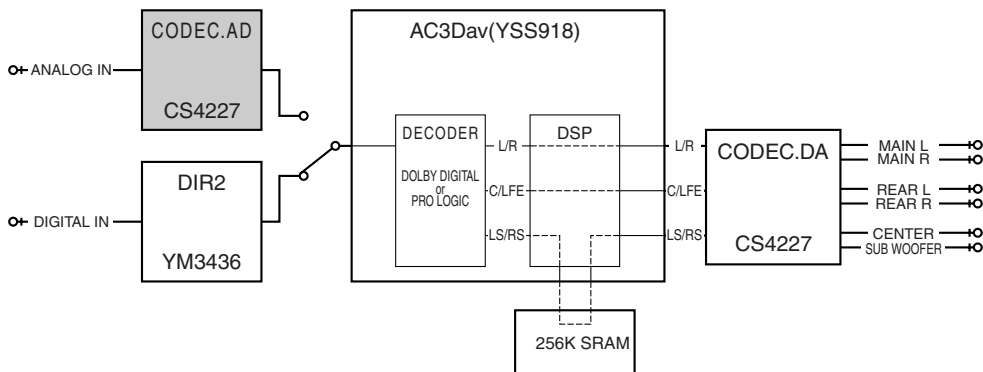

The shaded square means that the element included in it does not operate.

Status information

AC3 48k 3/2

Sampling frequency

Number of channels

Sampling frequency	(Display)
Analog	Analo
32kHz	32k
44.1kHz	44.1k
48kHz	48k

Number of channels	
(Front/Rear)	(Display)
1+1	1+1
1/0	1/0
2/0	2/0
3/0	3/0
2/1	2/1
3/1	3/1
2/2	2/2
3/2 5.1ch	3/2
7.1 (DTS)	7.1

4. Pro Logic

The sub-menu items include selection of Pro-logic (The auto input balance is off.) and EFFECT OFF.

CENTER LARGE

When the analog, PCM audio or AC-3 2/0 mode is used, L, R, C, S signals are pro-logic decoded and output. When the AC-3 mode other than 2/0 is used, the pro logic function does not work and the signals are AC-3 reproduced.

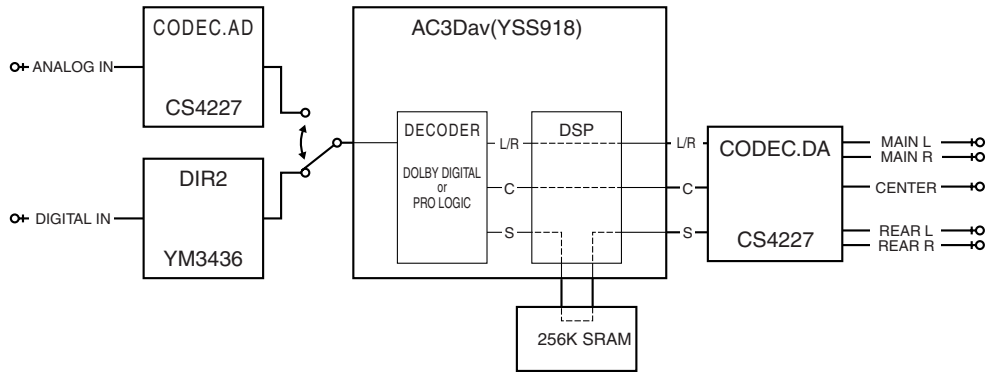

AUX IN : -20dBV, Both ch
 VOLUME : MAX

AUX IN : -20dBV, L ch only
 VOLUME : MAX

CN301 (Page 31, G3)
 MAIN L (1kHz) : <-45dBV
 MAIN R (1kHz) : <-45dBV
 SUBWOOFER (30Hz) : -28dBV
 REAR L (1kHz) : <-45dBV
 REAR R (1kHz) : <-45dBV
 CENTER (1kHz) : <-17dBV

CN301 (Page 31, G3)
 MAIN L (1kHz) : -20dBV
 MAIN R (1kHz) : <-45dBV
 SUBWOOFER (30Hz) : -32dBV
 REAR L (1kHz) : <-45dBV
 REAR R (1kHz) : <-45dBV
 CENTER (1kHz) : <-45dBV

EFFECT OFF

The L/R signal is output through MAIN BYPASS.

5. Speakers Set (for reference only)

This menu is for checking during the production process and not for servicing.

The input L/R signal is output through the specified channels according to the sub-menu.

There are 7 sub-menu items.

The signal output from the DSP section is normally in the EFFECT OFF state in the menus from 1 to

3. In the menus after that, the same signal as in the menu of 2. DSP THROUGH: YSS918 is output.

The analog switch settings in each sub-menu are as shown in the following table.

							Output					
Sub-menu		CENTER	REAR	MAIN	MAIN LEVEL	LFE/BASS	MAIN L	MAIN R	CENTER	REAR L	REAR R	SUBWOOFER
1	MAIN : SMALL 0dB	LARGE	LARGE	SMALL	0dB	SWFR	L	R	X	X	X	L+R
2	MAIN : LARGE 0dB	LARGE	LARGE	LARGE	0dB	SWFR	L	R	X	X	X	X
3	LFE/BASS : MAIN CENTER : NONE	NONE	LARGE	LARGE	0dB	MAIN	L	R	X	X	X	X
4	LFE/BASS : MAIN	LARGE	LARGE	LARGE	0dB	MAIN	LFE+FL	LFE+FR	X	X	X	X
5	LFE/BASS : SUBWOOFER	LARGE	LARGE	LARGE	0dB	SWFR	X	X	X	X	X	LFE
6	CENTER : NONE	NONE	LARGE	LARGE	0dB	SWFR	C+FL	C+FR	X	X	X	X
7	CENTER : SMALL REAR : SMALL	SMALL	SMALL	LARGE	0dB	SWFR	FL	FR	C	RL	RR	C+RL+RR+LFE

* In Sub-menu 1, the lower range content of the MAIN L/R is output at SWFR as well.

* In Sub-menu 7, the lower range content of LFE, CENTER and REAR is output at SWFR as well.

LARGE: Signals are output in all bandwidths.

SMALL: Only signals lower than 90Hz are mixed in the channel specified by LFE/BASS.

NONE: The center contents are distributed to the MAIN L/R channels after -3dB.

SWFR: SUBWOOFER

Output: The signal before MASTER VOLUME is indicated.

Sub-menu	Main application
MAIN : SMALL 0dB	Confirmation of high/low pass filter characteristics and gain when BASS REDIRECTION is used.
MAIN : LARGE 0dB	Reference for Sub-menu 1 and 2
LFE/BASS : MAIN CENTER : NONE	Confirmation of effect of the mix circuit to the main channel.
LFE/BASS : MAIN	Confirmation of gain of BASS MIX.
LFE/BASS : SUBWOOFER	Confirmation of the maximum output of LFE.
CENTER : NONE	Confirmation of gain of CENTER MIX.
CENTER : SMALL REAR : SMALL	Confirmation of high/low pass filter characteristics and gain when BASS REDIRECTION is used.

6. Effect Off

All effect functions are turned off.

7. Manual Test

The test noise is output by the noise generator with a built-in DSP through the channels specified by the sub-menu.

- ALL Noise is output through all channels.
- MAIN L Noise is output through the MAIN L channel.
- CENTER Noise is output through the CENTER channel.
- MAIN R Noise is output through the MAIN R channel.
- REAR R Noise is output through the REAR R channel.
- REAR L Noise is output through the REAR L channel.
- LFE Noise is output through the LFE (sub-woofer) channel.

- The sensitivity setting of the Auto Power OFF function is as follows.

Display	Sensitivity
1	Input signal level 3mVr.m.s.
2	Input signal level 5mVr.m.s.
3	Input signal level 10mVr.m.s.

IC DATA

IC3 : YM3436DK

DIR (Digital Format Interface Receiver)

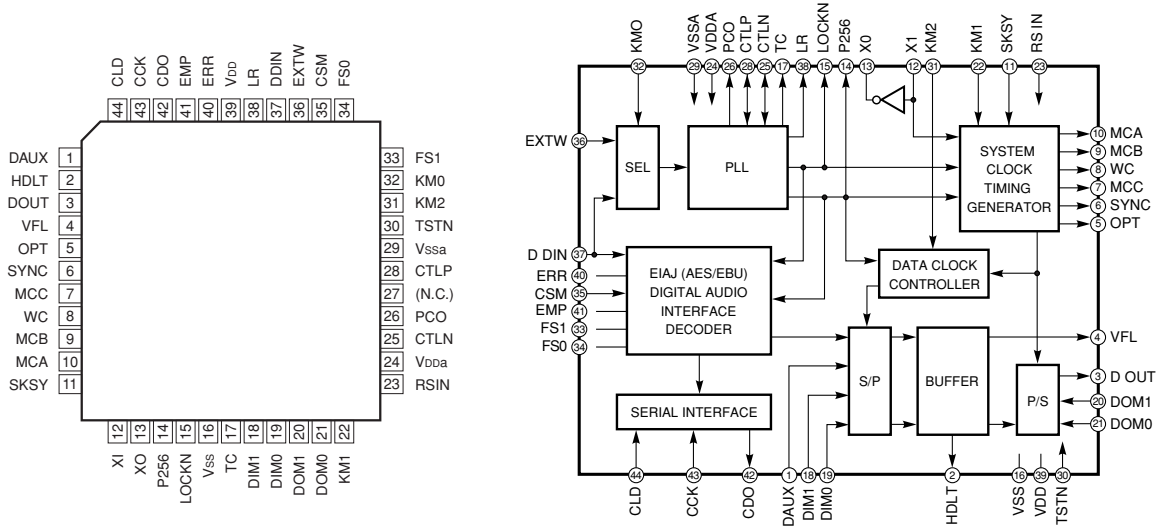

Pin No.	Pin Name	I/O	Function	Pin No.	Pin Name	I/O	Function
1	DAUX	I	Auxiliary input for audio data	26	PCO	O	PLL phase comparison output
2	HDLT	O	Asynchronous buffer operation flag	27	(NC)		
3	DOUT	O	Audio data output	28	CTLP	I	VCO control input P
4	VFL	O	Parity flag output	29	Vssa		VCO section power (GND)
5	OPT	O	Fs x 1 Synchronous output signal for DAC	30	TSTN	I	Test terminal. Open for normal use
6	SYNC	O	Fs x 1 Synchronous output signal for DSP	31	KM2	I	Clock mode switching input 2
7	MCC	O	Fs x 64Bit clock output	32	KM0	I	Clock mode switching input 0
8	WC	O	Fs x 1Word clock output	33	FS1	O	Channel status sampling frequency display output 1
9	MCB	O	Fs x 128Bit clock output	34	FS0	O	Channel status sampling frequency display output 0
10	MCA	O	Fs x 256Bit clock output	35	CSM	I	Channel status output method selection
11	SKSY	I	Clock synchronization control input	36	EXTW	I	External synchronous auxiliary input word clock
12	XI	I	Crystal oscillator connection or external clock input	37	DDIN	I	EIAJ (AES/EBU) data input
13	XO	O	Crystal oscillator connection	38	LR	O	PLL word clock output
14	P256	O	VCO oscillating clock connection	39	Vdd		Logic section power (+5V)
15	LOCK	O	PLL lock flag	40	ERR	O	Data error flag output
16	Vss		Logic section power (GND)	41	EMP	O	Channel status emphasis control code output
17	TC	O	PLL time constant switching output	42	CD0	O	3-wire type microcomputer interface data output
18	DIM1	I	Data input mode selection	43	CCK	I	3-wire type microcomputer interface clock input
19	DIM0	I	Data input mode selection	44	CLD	I	3-wire type microcomputer interface load input
20	DOM1	I	Data output mode selection				
21	DOM0	I	Data output mode selection				
22	KM1	I	Clock mode switching input 1				
23	RSTN	I	System reset input				
24	Vdda		VCO section power (+5V)				
25	CTLN	I	VCO control input N				

AV-S77

IC4 : YSS918D-F
AC3Dav

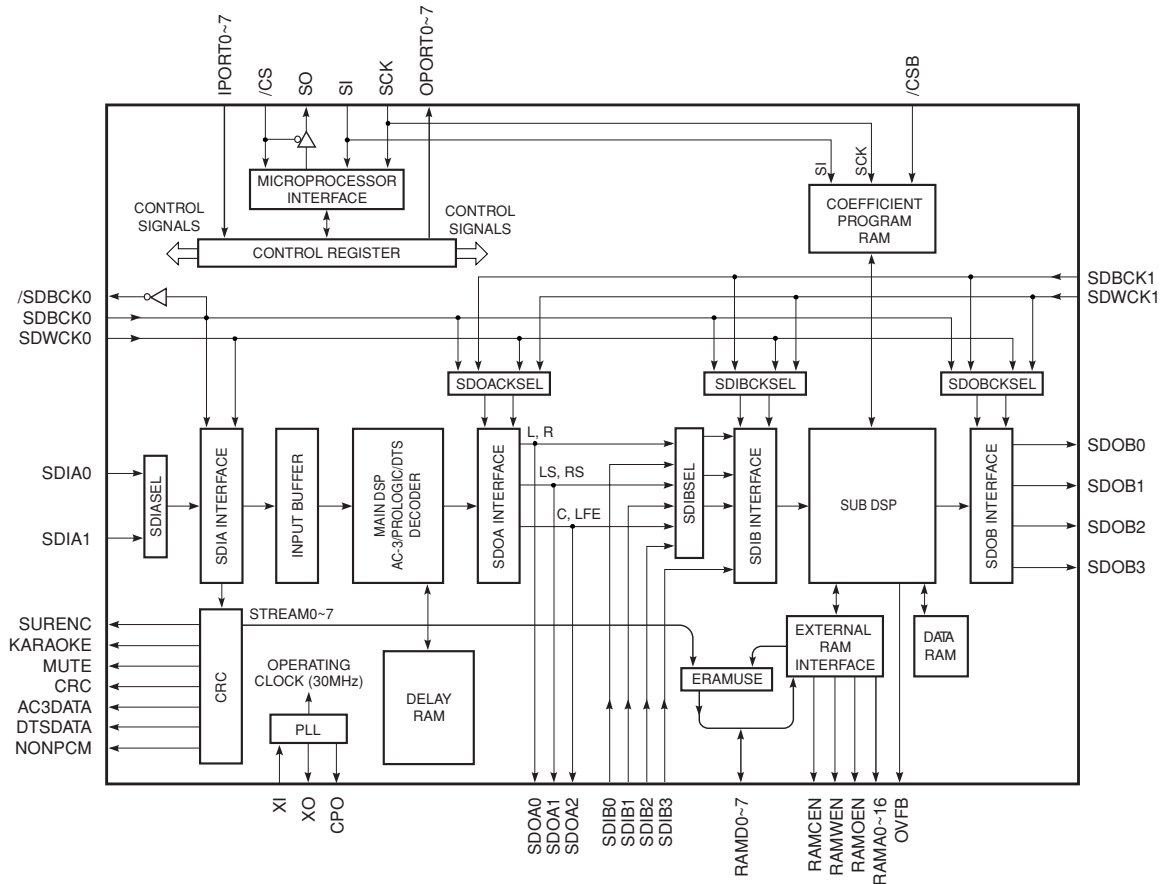
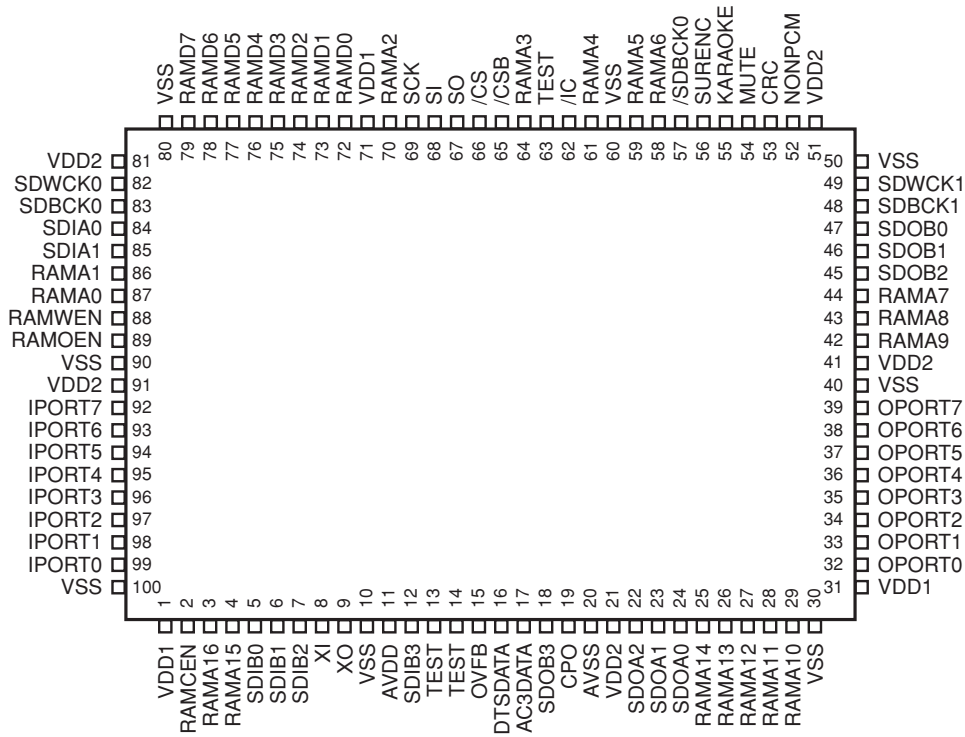

IC4 : YSS918D-F
AC3Dav

No.	Name	I/O	Function
1	VDD		+5V power supply (for terminal section)
2	RAMCEN	O	External SRAM chip enable terminal
3	RAMA16	O	External SRAM address terminal 16
4	RAMA15	O	External SRAM address terminal 15
5	SDIB0	Itp	PCM input terminal 0 to Sub DSP
6	SDIB1	Itp	PCM input terminal 1 to Sub DSP
7	SDIB2	Itp	PCM input terminal 2 to Sub DSP
8	XI	Ic	Crystal oscillator connecting terminal (12.288MHz)
9	XO	O	Crystal oscillator connecting terminal
10	VSS		Ground terminal (for terminal section)
11	AVDD		+3.3V power terminal (for PLL circuit)
12	SDIB3	Itp	PCM input terminal 3 to Sub DSP
13	TEST		Test terminal (unconnected)
14	TEST		Test terminal (unconnected)
15	OVFB	O	Sub DSP overflow detect terminal
16	DTSDATA	O	DTS data detect terminal
17	AC3DATA	O	AC-3 data detect terminal
18	SDOB3	O	PCM output terminal from Sub DSP
19	CPO	A	PLL output terminal (connected to external analog filter circuit)
20	AVSS		Ground terminal (for PLL circuit)
21	VDD2		+3.3V power terminal (for internal circuit)
22	SDOA2	O	PCM output terminal from Main DSP (C/LFE output at AC-3/DTS, C/S output at Pro Logic)
23	SDOA1	O	PCM output terminal from Main DSP (LS/RS output at AC-3/DTS, Lt/Rt output at Pro Logic)
24	SDOA0	O	PCM output terminal from Main DSP (L/R output at both AC-3/DTS and Pro Logic)
25	RAMA14	O	External SRAM address terminal 14
26	RAMA13	O	External SRAM address terminal 13
27	RAMA12	O	External SRAM address terminal 12
28	RAMA11	O	External SRAM address terminal 11
29	RAMA10	O	External SRAM address terminal 10
30	VSS		Ground terminal (for internal circuit)
31	VDD1		+5V power terminal (for terminal section)
32	OPORT0	O	General purpose output terminal (ISL0 : DIGITAL INPUT SEL)
33	OPORT1	O	General purpose output terminal (ISL1 : DIGITAL INPUT SEL)
34	OPORT2	O	General purpose output terminal (ISL2 : DIGITAL INPUT SEL)
35	OPORT3	O	General purpose output terminal (RFSL : LD RF INPUT SEL)
36	OPORT4	O	General purpose output terminal (RSL0 : DIGITAL REC OUT SEL)
37	OPORT5	O	General purpose output terminal (RSL1 : DIGITAL REC OUT SEL)
38	OPORT6	O	General purpose output terminal (RSL2 : DIGITAL REC OUT SEL)
39	OPORT7	O	General purpose output terminal (ADSL : AD INPUT SEL)
40	VSS		Ground terminal (for internal circuit)
41	VDD2		+3.3V power terminal (for internal circuit)
42	RAMA9	O	External SRAM address terminal 9
43	RAMA8	O	External SRAM address terminal 8
44	RAMA7	O	External SRAM address terminal 7
45	SDOB2	O	PCM output terminal from Sub DSP
46	SDOB1	O	PCM output terminal from Sub DSP
47	SDOB0	O	PCM output terminal from Sub DSP
48	SDBCK1	Itp	Bit clock input terminal for SDOA, SDIB, SDOB signals
49	SDWCK1	Itp	Word clock input terminal for SDOA, SDIB, SDOB signals
50	VSS		Ground terminal (for terminal section)
51	VDD2		+3.3V power terminal (for internal circuit)
52	NONPCM	O	Non-PCM data detect terminal

IC4 : YSS918D-F
AC3Dav

No.	Name	I/O	Function
53	CRC	O	AC-3 CRC error detect terminal
54	MUTE	O	Auto mute detect terminal
55	KARAOKE	O	AC-3 KARAOKE data detect terminal
56	SURENC	O	AC-3 2/0 mode Dolby surround encode input detect terminal
57	/SDBCK0	O	SDBCK0 invert clock output terminal
58	RAMA6	O	External SRAM address terminal 6
59	RAMA5	O	External SRAM address terminal 5
60	VSS		Ground terminal (for internal circuit)
61	RAMA4	O	External SRAM address terminal 4
62	/IC	Ics	Initial clear terminal
63	TEST		Test terminal (unconnected)
64	RAMA3	O	External SRAM address terminal 3
65	/CSB	Itp	Sub DSP chip select input terminal
66	/CS	Ics	Microprocessor interface chip select input terminal
67	SO	O*	Microprocessor interface data output terminal
68	SI	Ics	Microprocessor interface and Sub DSP data input terminal
69	SCK	Ics	Microprocessor interface and Sub DSP clock input terminal
70	RAMA2	O	External SRAM address terminal 2
71	VDD1		+5V power terminal (for terminal section)
72	RAMD0	Itp/O	External SRAM data terminal (STREAM 0 output when external SRAM is not used)
73	RAMD1	Itp/O	External SRAM data terminal (STREAM 1 output when external SRAM is not used)
74	RAMD2	Itp/O	External SRAM data terminal (STREAM 2 output when external SRAM is not used)
75	RAMD3	Itp/O	External SRAM data terminal (STREAM 3 output when external SRAM is not used)
76	RAMD4	Itp/O	External SRAM data terminal (STREAM 4 output when external SRAM is not used)
77	RAMD5	Itp/O	External SRAM data terminal (STREAM 5 output when external SRAM is not used)
78	RAMD6	Itp/O	External SRAM data terminal (STREAM 6 output when external SRAM is not used)
79	RAMD7	Itp/O	External SRAM data terminal (STREAM 7 output when external SRAM is not used)
80	VSS		Ground terminal (for terminal section)
81	VDD2		+3.3V power terminal (for internal circuit)
82	SDWCK0	Ic	Word clock input terminal for SDIA, SDOA, SDIB and SDOB signals
83	SDBCK0	Ic	Bit clock input terminal for SDIA, SDOA, SDIB and SDOB signals
84	SDIA0	Ic	AC-3/DTS bit stream (or PCM) data input terminal to Main DSP
85	SDIA1	Ic	AC-3/DTS bit stream (or PCM) data input terminal to Main DSP
86	RAMA1	O	External SRAM address terminal 1
87	RAMA0	O	External SRAM address terminal 0
88	RAMWEN	O	External SRAM write enable terminal
89	RAMOEN	O	External SRAM output enable terminal
90	VSS		Ground terminal
91	VDD2		+3.3V power terminal (for internal circuit)
92	IPORT7	Itp	General purpose input terminal (Used for IC YSS908/918 identification: +3.3V)
93	IPORT6	Itp	General purpose input terminal (GND)
94	IPORT5	Itp	General purpose input terminal (GND)
95	IPORT4	Itp	General purpose input terminal (GND)
96	IPORT3	Itp	General purpose input terminal (GND)
97	IPORT2	Itp	General purpose input terminal (GND)
98	IPORT1	Itp	General purpose input terminal (GND)
99	IPORT0	Itp	General purpose input terminal (GND)
100	VSS		Ground terminal

Note) Listed below are symbols in the I/O column and their meanings.

Ic: CMOS level input terminal

Ic: TTL level input terminal

Ics: Schmidt trigger input terminal

Itp: Input terminal with pull-up resistor

O: Digital output terminal

O*: Tri-state digital output terminal

A: Analog input terminal

IC200 : M30217MA-A208FP (16 bit μ-COM)

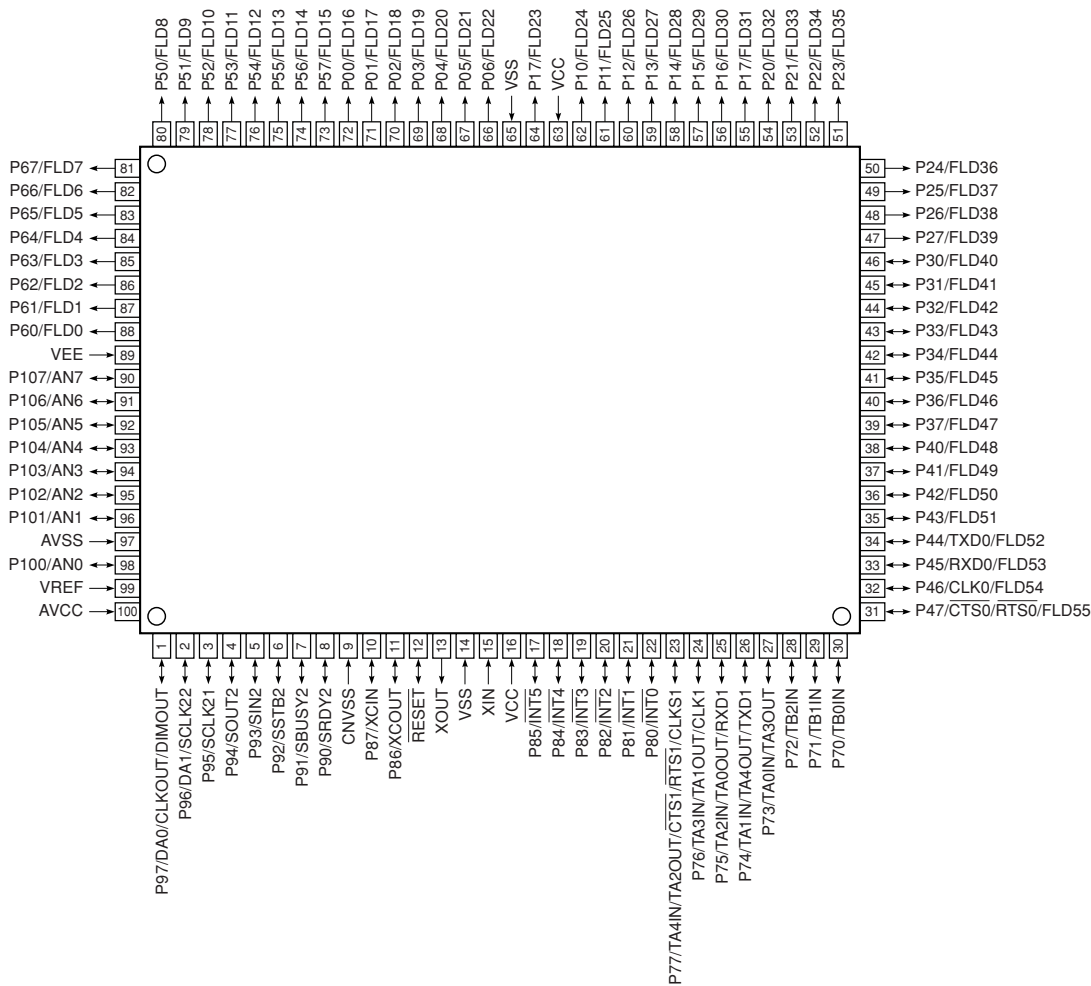

No.	PORT	Name	IN/OUT	Function
1	P97	CMOS	OUT	BASS BOOST [0:ON]
2	P96	CMOS	OUT	Center unit, RL,RR,SW MUTE OUT [0:MUTE ON]
3	P95	CMOS	OUT	LC78212 / TC9482 / (DSP) CODEC CLK OUT (SCK)
4	P94	CMOS	OUT	LC78212 / TC9482 / (DSP) CODEC DATA OUT (SDT)
5	P93	CMOS	OUT	(DSP) DIR2 CCK (CCK)
6	P92	CMOS	OUT	(DSP) DIR2 CLD (CLD) [0:DATA READ]
7	P91	CMOS	OUT	(DSP) AC3D CE1 OUT (CEAC1)
8	P90	CMOS	OUT	(DSP) AC3D CE2 OUT (CEAC2)
9	CNVSS	-	-	Connected to VSS (GND) via a resistance (5.1kΩ)
10	P87	CMOS	OUT	Switching of analog input (4052) to A OUT A B [00:TV 01:-]
11	P86	CMOS	OUT	Switching of analog input (4052) to B OUT [10:VIDEO 11:AUX]
12	RESET	-	-	RESET [0:RESET]
13	XOUT	-	-	10 MHz IN (Feedback resistance included)
14	VSS	-	-	GND
15	XIN	-	-	10 MHz IN (Feedback resistance included)
16	VCC	-	-	+5V power supply
17	P85	INT5	INT-IN	(DSP) DIR2 ERR IN (ERRD)
18	P84	INT4	INT-IN	(DSP) AC3D MUTE IN (ERRA)
19	P83	(INT3)	IN	(DSP) DIR2 CD0 IN (CD0)
20	P82	(INT2)	-	[Pull-down with 100kΩ]
21	P81	INT1	INT-IN	Remote controller IN
22	P80	INT0	INT-IN	Power down DC detect IN [0:POWER DOWN]

AV-S77

IC200 : M30217MA-A208FP (16 bit μ -COM)

No.	PORT	Name	IN/OUT	Function
23	P77	CMOS	OUT	(DSP) /IC AC3D OUT (/ICAC)
24	P76	CLK1	S-CLK	(DSP) AC3D CLK OUT(CLKAC) (Serial I/O-1)
25	P75	RxD1	S-IN	(DSP) AC3D DATA IN(RXAC) (Serial I/O-1)
26	P74	TxD1	S-OUT	(DSP) AC3D DATA OUT(TXAC) (Serial I/O-1)
27	P73	CMOS	OUT	(DSP) CODEC CE OUT (CECOD) [0: DATA transfer]
28	P72	CMOS	OUT	Analog switch (LC78212) CE OUT [0: Address 1: Data]
29	P71	CMOS	OUT	Electronic VR (TC9482) STB OUT [1:ON]
30	P70	CMOS	OUT	CE OUT to E2PROM [1: DATA transfer]
31	P47	CTS0	OUT	Busy OUT to flash writer [1:ON]
32	P46	CLK0	S-CLK	CLK OUT to E2PROM/CLK IN from flash writer (Serial I/O-0)
33	P45	RxD0	S-IN	DATA IN from E2PROM/DATA IN from flash writer (Serial I/O-0)
34	P44	TxD0	S-OUT	DATA OUT to E2PROM/DATA OUT from flash writer (Serial I/O-0)
35	P43	P-OD	OUT	Headphones is connect/Unconnect IN [1:Connect]
36	P42	P-OD	OUT	Rear speaker relay control OUT [1:ON]
37	P41	P-OD	OUT	Main & Subwoofer speaker relay control OUT [1:ON]
38	P40	P-OD	OUT	STANDBY LED OUT (Direct drive Max: 18mA) [1: light up]
39	P37	FLD47	OUT	DIGIT 13 (13G) [VEE external pull-down required]
40	P36	FLD46	OUT	DIGIT 12 (12G) [VEE external pull-down required]
41	P35	FLD45	OUT	DIGIT 11 (11G) [VEE external pull-down required]
42	P34	FLD44	OUT	DIGIT 10 (10G) [VEE external pull-down required]
43	P33	FLD43	OUT	DIGIT 9 (9G) [VEE external pull-down required]
44	P32	FLD42	OUT	DIGIT 8 (8G) [VEE external pull-down required]
45	P31	FLD41	OUT	DIGIT 7 (7G) [VEE external pull-down required]
46	P30	FLD40	OUT	DIGIT 6 (6G) [VEE external pull-down required]
47	P27	FLD39	OUT	DIGIT 5 (5G) [VEE external pull-down required]
48	P26	FLD38	OUT	DIGIT 4 (4G) [VEE external pull-down required]
49	P25	FLD37	OUT	DIGIT 3 (3G) [VEE external pull-down required]
50	P24	FLD36	OUT	DIGIT 2 (2G) [VEE external pull-down required]
51	P23	FLD35	OUT	DIGIT 1 (1G) [VEE external pull-down required]
52	P22	FLD34	OUT	SEGMENT 1 (P1) [VEE external pull-down required]
53	P21	FLD33	OUT	SEGMENT 2 (P2) [VEE external pull-down required]
54	P20	FLD32	OUT	SEGMENT 3 (P3) [VEE external pull-down required]
55	P17	FLD31	OUT	SEGMENT 4 (P4) (VEE internal pull-down)
56	P16	FLD30	OUT	SEGMENT 5 (P5) (VEE internal pull-down)
57	P15	FLD29	OUT	SEGMENT 6 (P6) (VEE internal pull-down)
58	P14	FLD28	OUT	SEGMENT 7 (P7) (VEE internal pull-down)
59	P13	FLD27	OUT	SEGMENT 8 (P8) (VEE internal pull-down)
60	P12	FLD26	OUT	SEGMENT 9 (P9) (VEE internal pull-down)
61	P11	FLD25	OUT	SEGMENT 10 (P10) (VEE internal pull-down)
62	P10	FLD24	OUT	SEGMENT 11 (P11) (VEE internal pull-down)
63	VCC	-	-	+5V power supply
64	P07	FLD23	OUT	SEGMENT 12 (P12) (VEE internal pull-down)
65	VSS	-	-	GND
66	P06	FLD22	OUT	SEGMENT 13 (P13) (VEE internal pull-down)
67	P05	FLD21	OUT	SEGMENT 14 (P14) (VEE internal pull-down)
68	P04	FLD20	OUT	SEGMENT 15 (P15) (VEE internal pull-down)
69	P03	FLD19	OUT	SEGMENT 16 (P16) (VEE internal pull-down)
70	P02	FLD18	OUT	SEGMENT 17 (P17) (VEE internal pull-down)
71	P01	FLD17	OUT	SEGMENT 18 (P18) (VEE internal pull-down)
72	P00	FLD16	OUT	SEGMENT 19 (P19) (VEE internal pull-down)
73	P57	FLD15	OUT	SEGMENT 20 (P20) (VEE internal pull-down)
74	P56	FLD14	OUT	SEGMENT 21 (P21) (VEE internal pull-down)
75	P55	FLD13	OUT	SEGMENT 22 (P22) (VEE internal pull-down)
76	P54	FLD12	OUT	SEGMENT 23 (P23) (VEE internal pull-down)
77	P53	FLD11	OUT	SEGMENT 24 (P24) (VEE internal pull-down)

IC200 : M30217MA-A208FP (16 bit μ -COM)

No.	PORT	Name	IN/OUT	Function
78	P52	FLD10	OUT	SEGMENT 25 (P25) (VEE internal pull-down)
79	P51	FLD9	OUT	SEGMENT 26 (P26) (VEE internal pull-down)
80	P50	FLD8	OUT	SEGMENT 27 (P27) (VEE internal pull-down)
81	P67	FLD7	OUT	SEGMENT 28 (P28) (VEE internal pull-down)
82	P66	FLD6	OUT	SEGMENT 29 (P29) (VEE internal pull-down)
83	P65	FLD5	OUT	SEGMENT 30 (P30) (VEE internal pull-down)
84	P64	FLD4	OUT	SEGMENT 31 (P31) (VEE internal pull-down)
85	P63	FLD3	OUT	SEGMENT 32 (P32) (VEE internal pull-down)
86	P62	FLD2	OUT	SEGMENT 32 (P33) (VEE internal pull-down)
87	P61	FLD1	OUT	SEGMENT 34 (P34) (VEE internal pull-down)
88	P60	FLD0	OUT	SEGMENT 35 (P35) (VEE internal pull-down)
89	VEE	-	-	P0, P1, P5, P6 pull-down resistance voltage input [-29V]
90	P107	AN7	A-D IN	SW protection IN [4.0-5.0V:SW provided, 0-2.0V:SW protection ON]
91	P106	AN6	A-D IN	AUTO POWER ON/OFF identify IN (music signal) [0 — VREF]
92	P105	AN5	A-D IN	Center unit power supply voltage detect IN (protection) [0 — VREF]
93	P104	CMOS	OUT	Night mode switching OUT [0:ON]
94	P103	CMOS	OUT	Center unit power supply OUT [1:ON]
95	P102	AN2	A-D IN	Destination select input [Pull-up with 10k Ω > VREF]
96	P101	AN1	A-D IN	KEY 1 input [Pull-up with 10k Ω > VREF]
97	AVSS	-	-	Connected to VSS (GND)
98	P100	AN0	A-D IN	KEY O input [Pull-up with 10k Ω > VREF]
99	VREF	-	-	A-D, D-A reference voltage input [— VCC]
100	AVCC	-	-	Connected to VCC terminal (+5V)

● KEY input (A-C) Pull-up resistance 10k Ω

Ω	0	+2k	+1.8k	+2.4k	+3.9k	+5.6k	+10k	+24k
V	— 0.556	— 1.111	— 1.667	— 2.222	— 2.778	— 3.333	— 3.889	— 4.444
KEY 0 (98pin)	STANDBY/ON	VOLUME ∨	VOLUME ∧	NO KEY	NO KEY	NO KEY	NO KEY	NO KEY
KEY 1 (96pin)	DSP	INPUT	NO KEY	NO KEY	NO KEY	NO KEY	NO KEY	NO KEY

● Destination select input (95 pin A-D) Pull-up resistance 10k Ω

Ω	2k	51k
V	0.556 — 1.111	3.889 — 4.444
Destination	Ex (English)	J model (Japanese)

■ DISPLAY DATA

● V200 : 13-BT-180GNK (V629140)

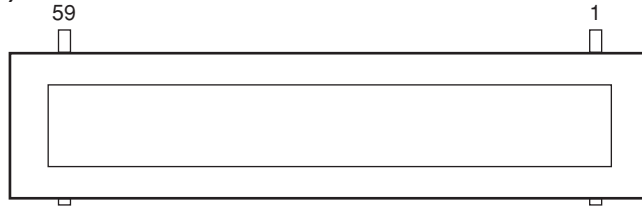

● PIN CONNECTION

Pin No.	30	29	28	27	26	25	24	23	22	21	20	19	18	17	16	15	14	13	12	11	10	9	8	7	6	5	4	3	2	1
Connection	P11	P12	P13	P14	P15	P16	P17	P18	P19	P20	P21	P22	P23	P24	P25	P26	P27	P28	P29	P30	P31	P32	P33	P34	P35	NX	NP	NP	F1	F1
Pin No.	59	58	57	56	55	54	53	52	51	50	49	48	47	46	45	44	43	42	41	40	39	38	37	36	35	34	33	32	31	
Connection	F2	F2	NP	NP	NX	13G	12G	11G	10G	9G	8G	7G	6G	5G	3G	2G	1G	1G	NX	P1	P2	P3	P4	P5	P6	P7	P8	P9	P10	

Note : 1) F1, F2 Filament 2) NP No pin 3) NX No extended pin 4) DL Datum Line 5) 1G ~ 13G Grid

● GRID ASSIGNMENT

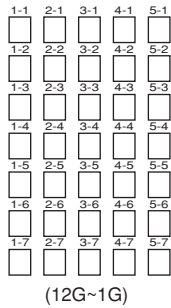
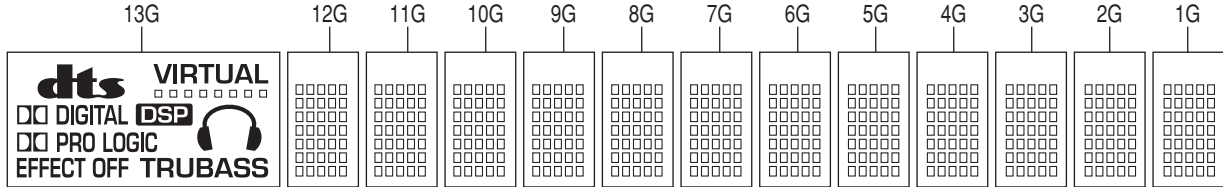

● ANODE CONNECTION

	13G	12G~1G
P1	TRUBASS	1-1
P2	—	2-1
P3	—	3-1
P4	VIRTUAL	4-1
P5	□□ (DIGITAL)	5-1
P6	DIGITAL	1-2
P7	dts	2-2
P8	EFFECT OFF	3-2
P9	□□□□□□□□	4-2
P10	□□ (PRO LOGIC)	5-2
P11	PRO LOGIC	1-3
P12	DSP	2-3
P13	🎧	3-3
P14	—	4-3
P15	—	5-3
P16	—	1-4
P17	—	2-4
P18	—	3-4

	13G	12G~1G
P19	—	4-4
P20	—	5-4
P21	—	1-5
P22	—	2-5
P23	—	3-5
P24	—	4-5
P25	—	5-5
P26	—	1-6
P27	—	2-6
P28	—	3-6
P29	—	4-6
P30	—	5-6
P31	—	1-7
P32	—	2-7
P33	—	3-7
P34	—	4-7
P35	—	5-7

■ BLOCK DIAGRAM

Input Selector Unit & DSP Unit

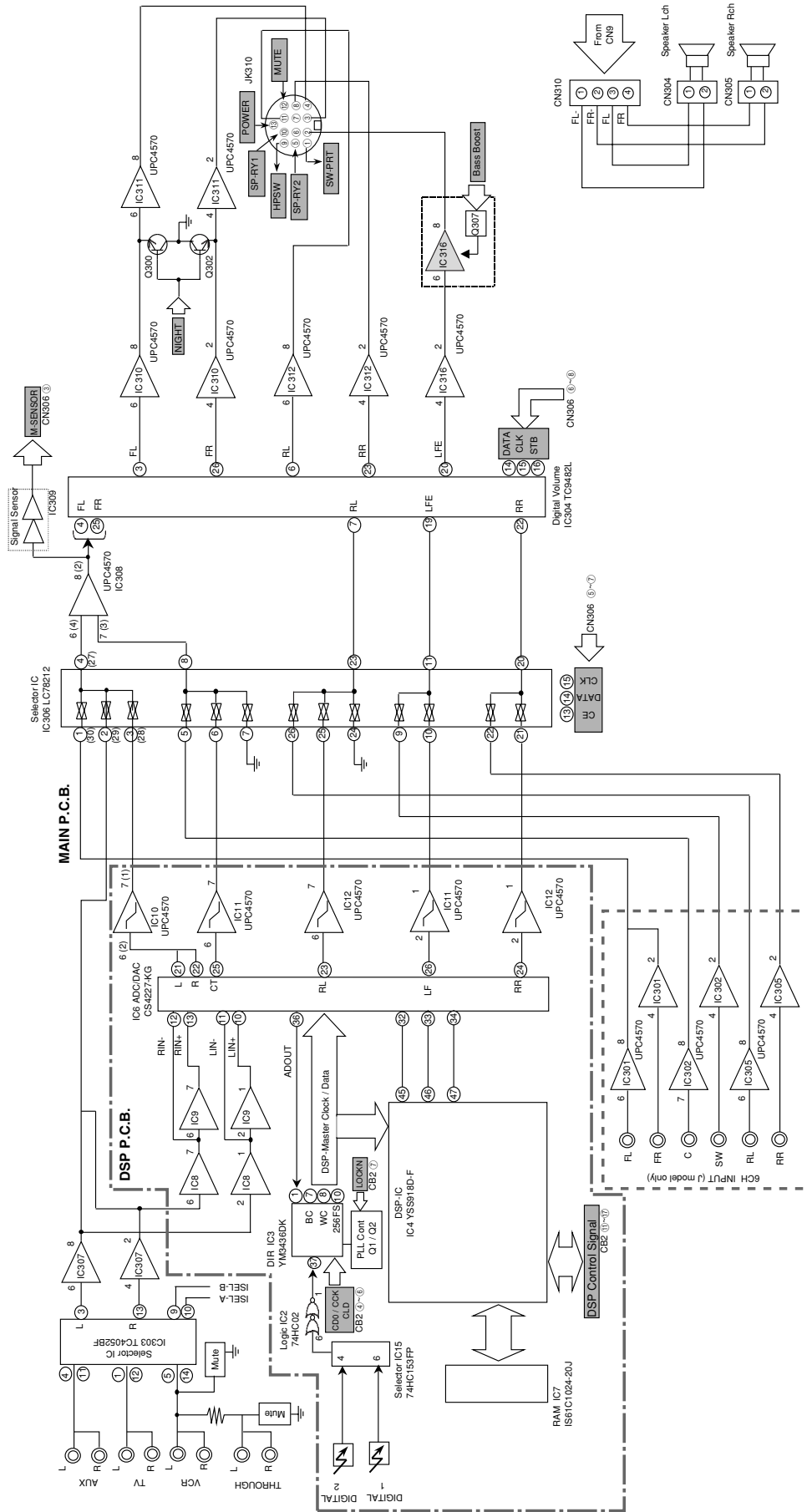

AV-S77

1 **μ-COM & Power Supply**

2
3
4
5
6
7

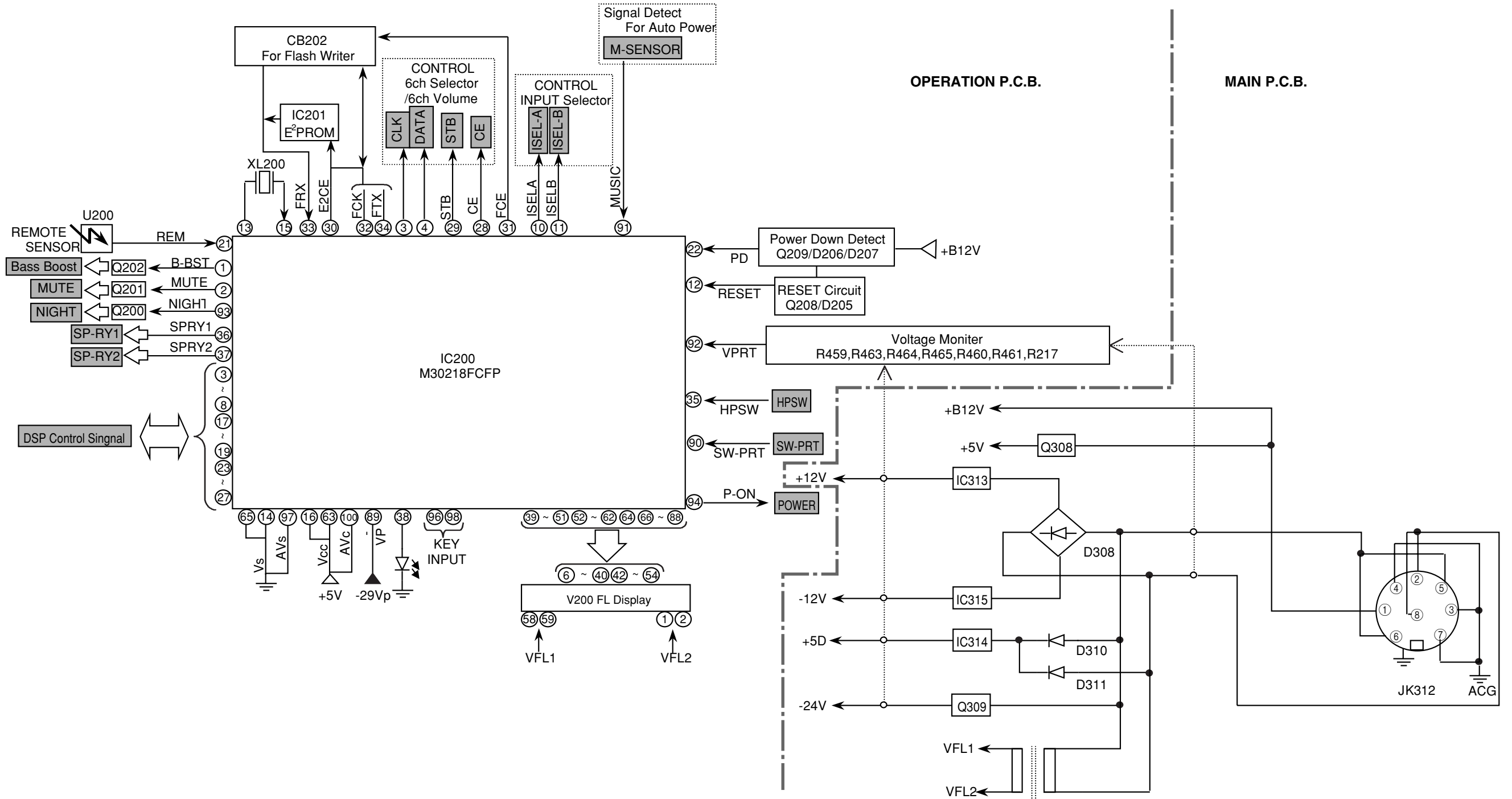

Subwoofer & Rear Amplifier

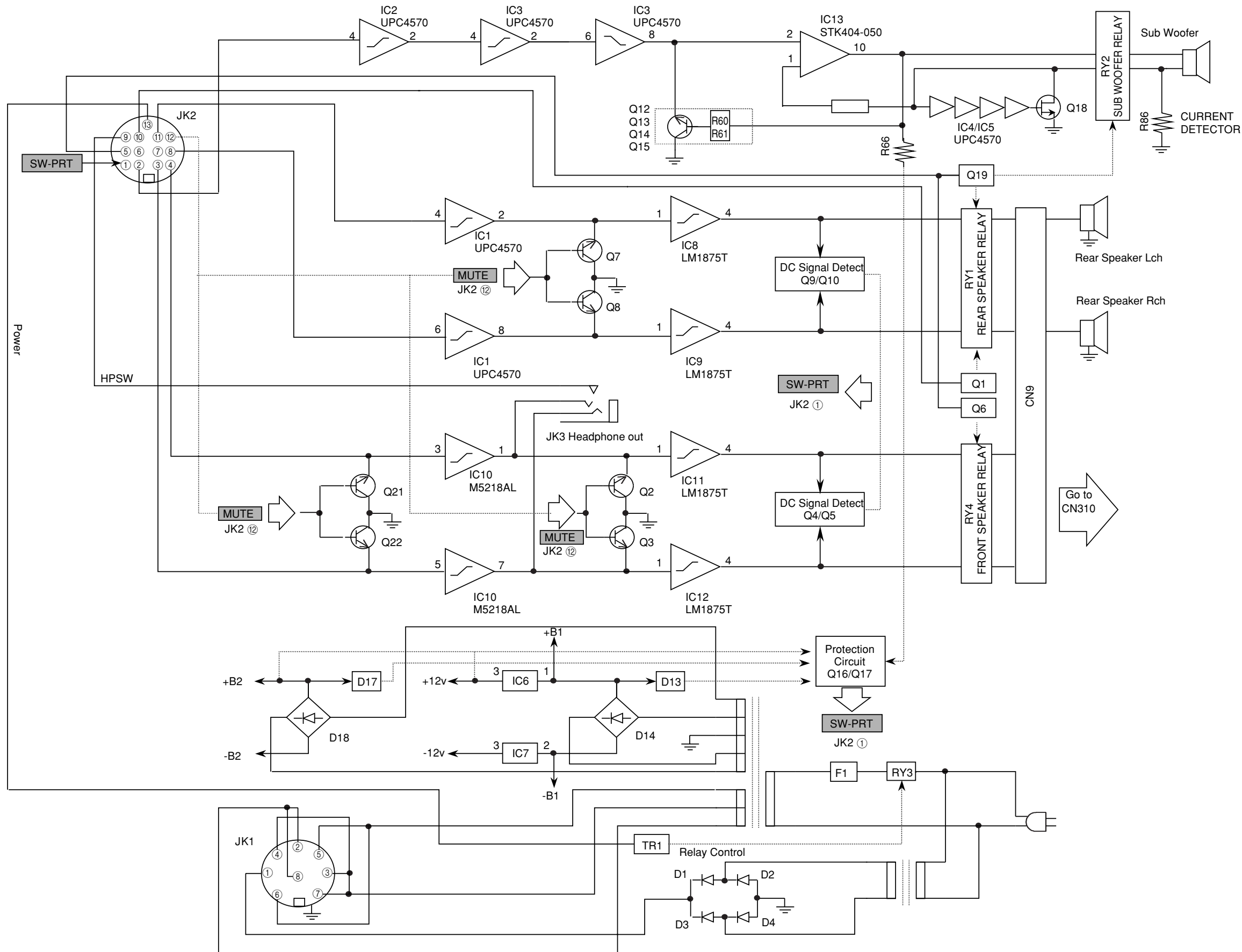

JK1

1	+B12V
2	AC2
3	ACG
4	ACG
5	AC1
6	AC1
7	ACG
8	AC2

JK2

1	SW-PRT
2	SW
3	FR
4	FL
5	SP-RY2
6	NC
7	GND
8	PR
9	E
10	SP-RY1
11	RL
12	MUTE
13	POWER

AV-S77C PRINTED CIRCUIT BOARD (Foil side)

MAIN P. C. B. (Lead Type Device 2/2)

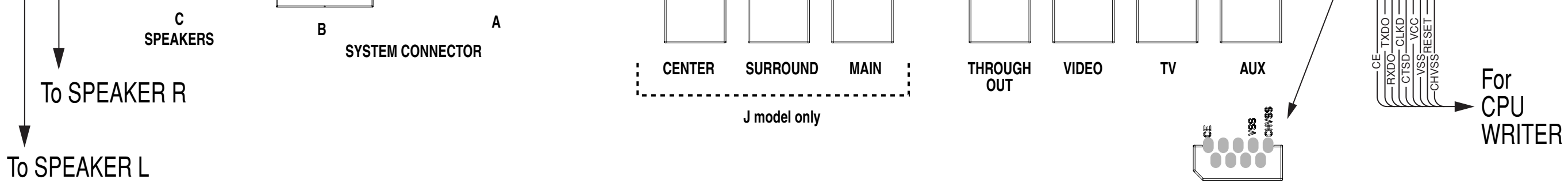
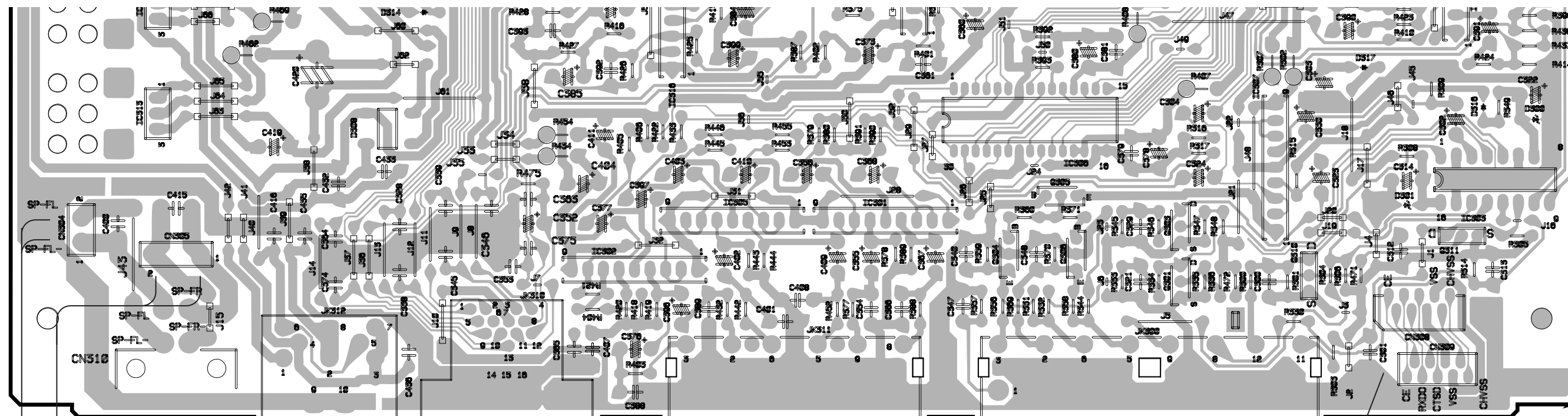

• Semiconductor Location

Ref. No.	Location	Ref. No.	Location
D300	J2	IC307	H3
D301	I3	IC313	B2
D308	C3	Q301	H3
D316	I2	Q303	H3
D317	I2	Q304	G3
IC301	F3	Q305	G3
IC302	E3	Q306	G3
IC303	I3	Q310	H3
IC304	G3	Q311	I3
IC306	G3		

■ AV-S77C PRINTED CIRCUIT BOARD (Component side)

DSP P. C. B. (Lead Type Device)

DSP P. C. B. (Surface Mount Device)

From OPERATION → ← From MAIN

• Semiconductor Location

Ref. No.	Location
D1	C5
D2	D5
D3	I3
D4	I3
D5	E5
D6	E5
D7	E5
D8	E5
D9	E5
D10	E5
D11	E4
D12	E5
IC1	C5
IC2	C5
IC3	C5
IC4	C4
IC6	D5
IC7	C3
IC8	E3
IC9	E5
IC10	E4
IC11	D4
IC12	E4
IC14	D4
IC15	D5
Q1	C5
Q2	C5

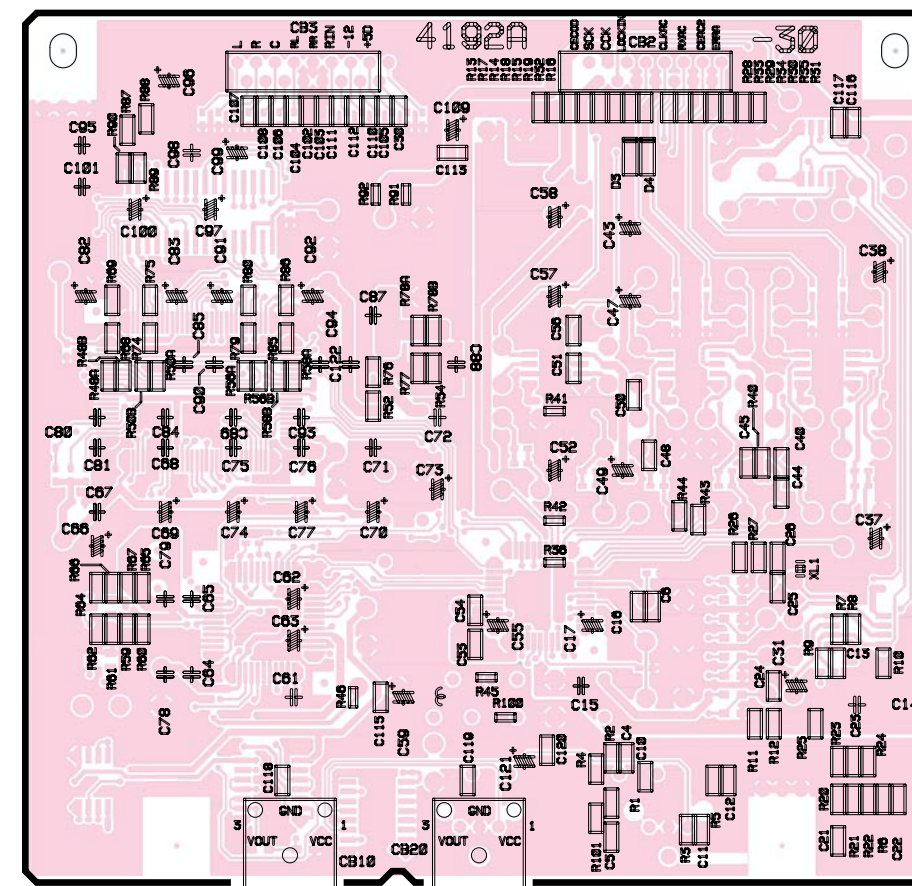
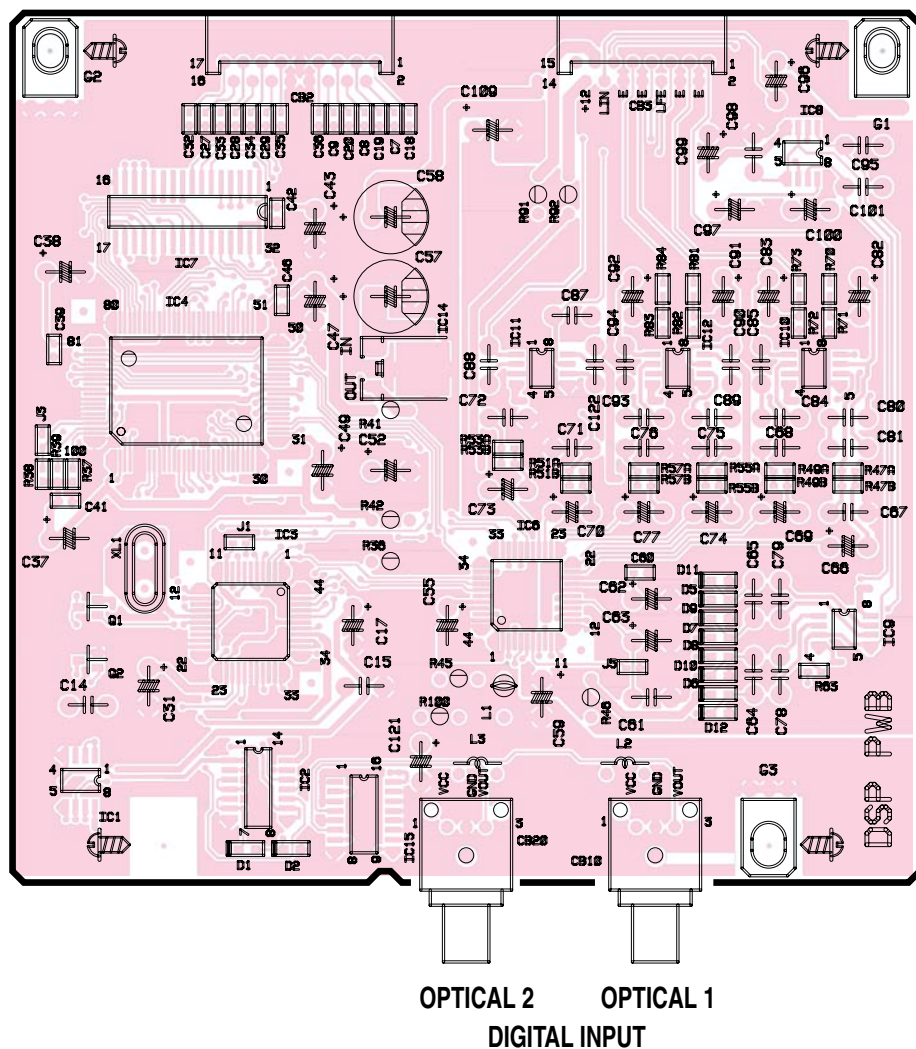

■ NX-SW77 PRINTED CIRCUIT BOARD (Foil side)

• Semiconductor Location

Ref. No.	Location
D6	E3
D7	E3
D8	D3
D9	E3
D10	E3
D11	E3
D16	H3
D19	E3
D20	E3
D21	G3
D22	D2
D23	D2
IC1	H4
IC2	D4
IC3	E4
IC4	D3
IC8	H2
IC9	H2
IC10	G4
IC11	G2
IC12	G2
IC13	D2

From POWER (A)
CN2

AMP (C) P. C. B. (Lead Type Device)

AMP (D) P. C. B. (Lead Type Device)

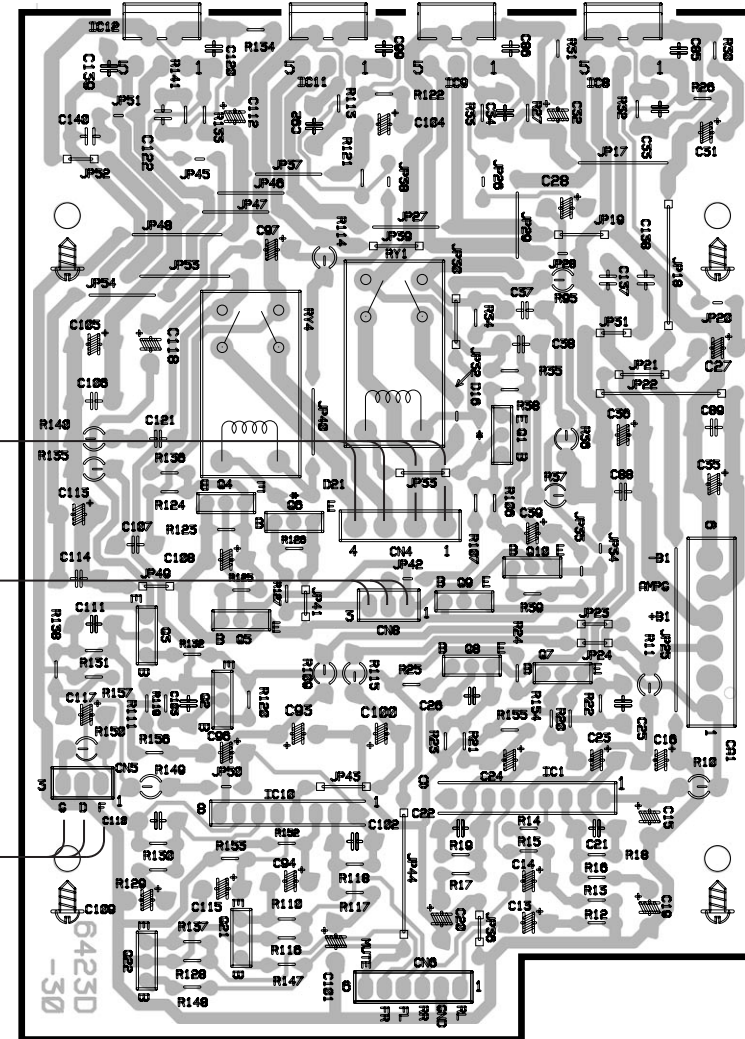
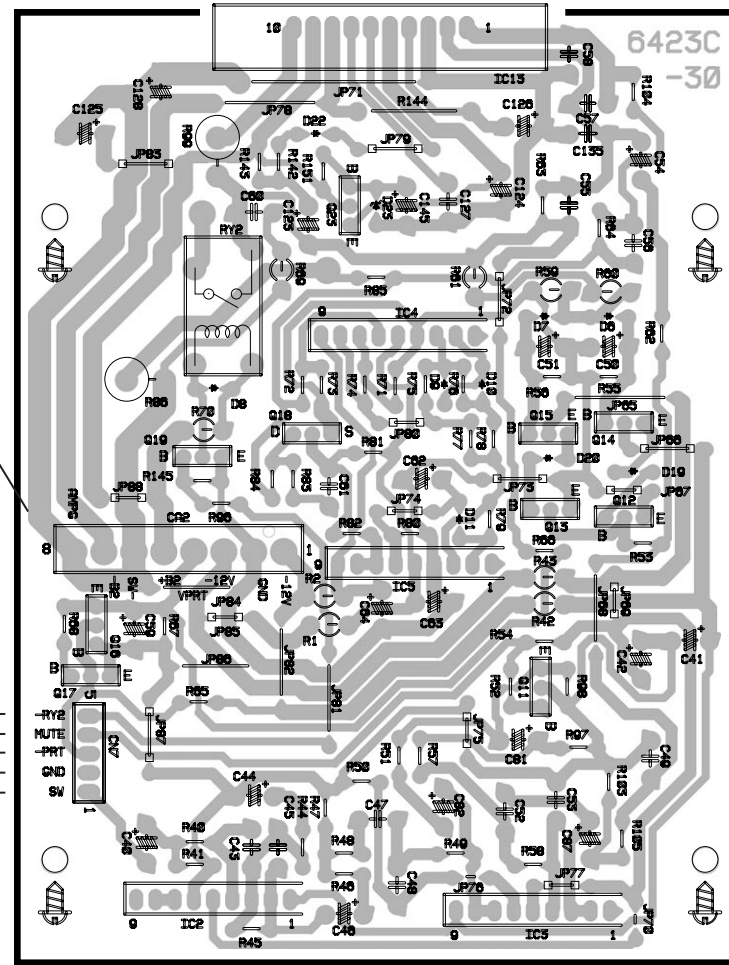
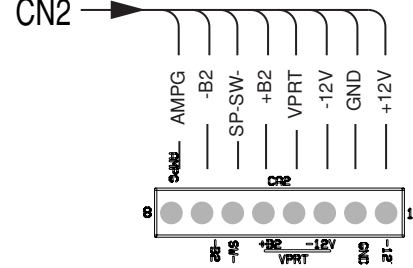

From AMP (E)
CA6

To AMP (F)
CA4

To AMP (E)
CA6

From AMP (F)
CA5

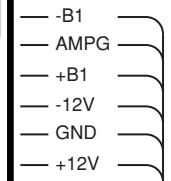

From POWER (A)
CN1

AMP (E) P. C. B.
(Lead Type Device)

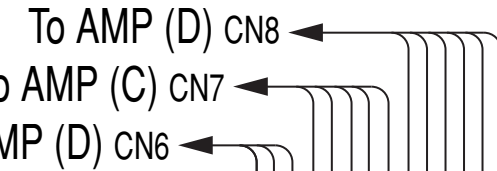

From POWER (B) CN10
From POWER (A) CN3

AMP (F) P. C. B.
(Lead Type Device)

To AMP (D)
CN5

From POWER (A) CN11
From AMP (D) CN4

From AMP (E)
CA6

• Semiconductor Location

Ref. No.	Location
Q1	H3
Q2	G4
Q3	G4
Q4	G3
Q5	G4
Q6	G3
Q7	H4
Q8	H4
Q9	H3
Q10	H3
Q11	E4
Q12	E3
Q13	E3
Q14	E3
Q15	E3
Q16	C4
Q17	C4
Q18	D3
Q19	D3
Q21	G5
Q22	G5
Q23	D2

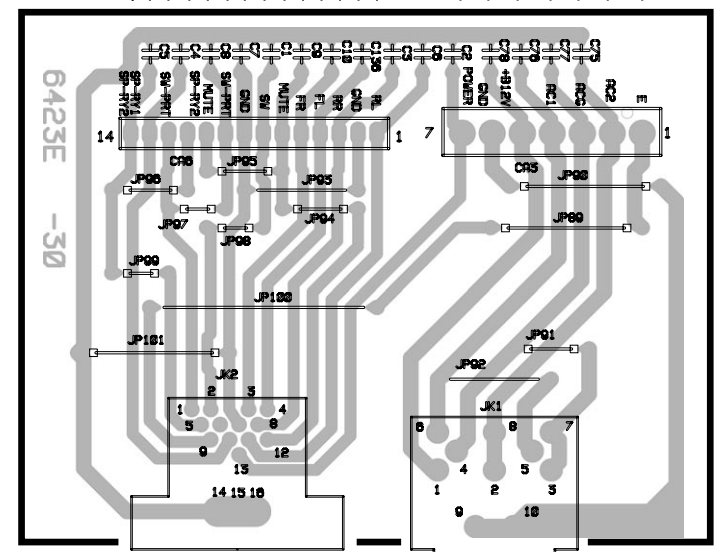

SYSTEM CONNECTOR B (WHITE 13P)
SYSTEM CONNECTOR A (BLACK 8P)

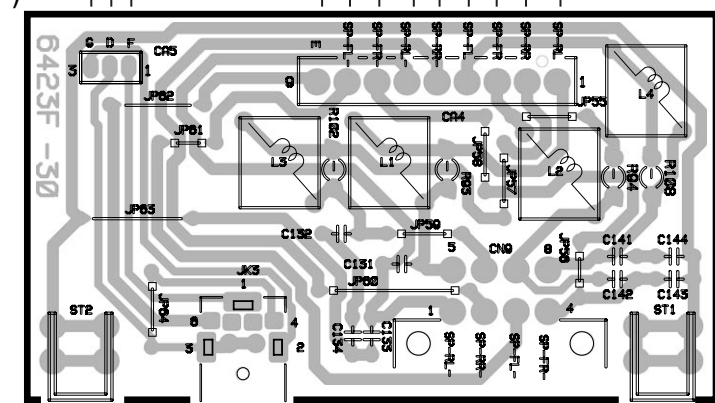

■ NX-SW77 PRINTED CIRCUIT BOARD (Component side)

• Semiconductor Location

Ref. No.	Location
D1	I3
D2	I3
D3	I3
D4	I3
D5	E3
D12	E3
D13	D5
D14	C5
D15	H2
D17	F5
D18	E5
IC6	C4
IC7	C4

POWER (A) P. C. B. (Lead Type Device)

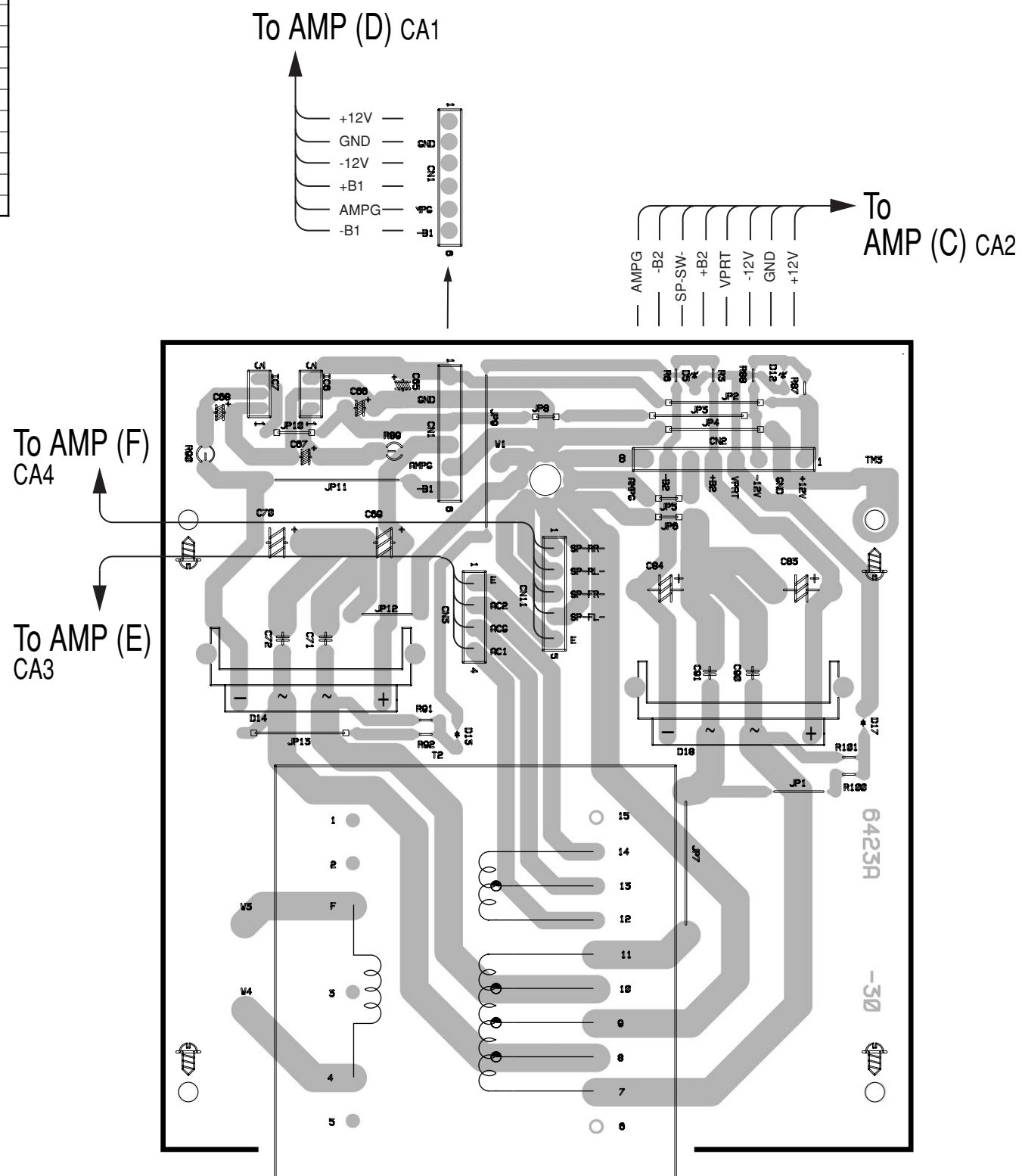

POWER (B) P. C. B. (Lead Type Device)

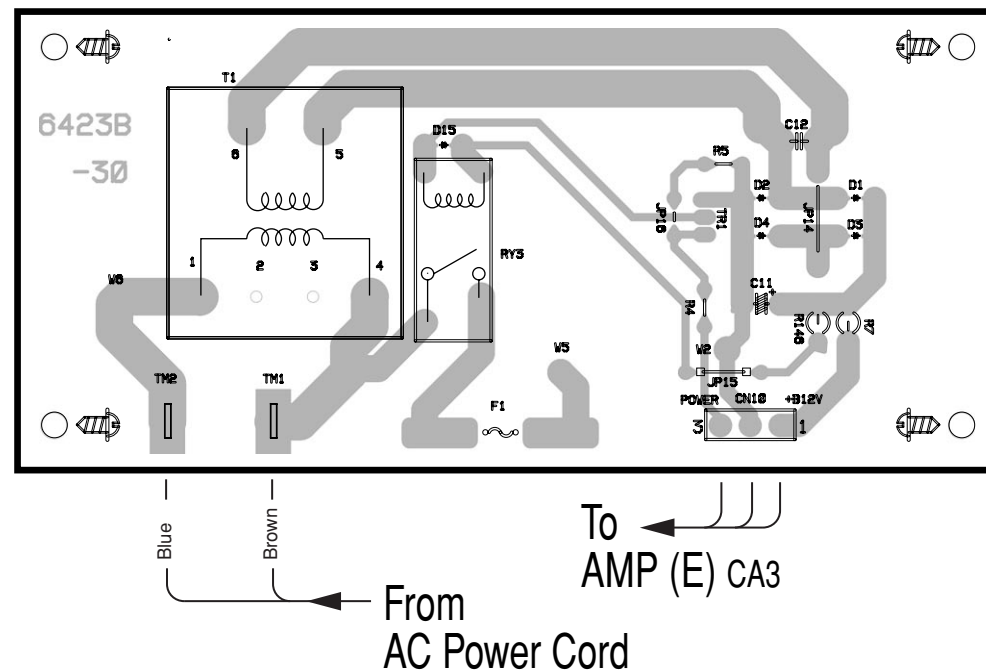

AV-S77C SCHEMATIC DIAGRAM (MAIN)

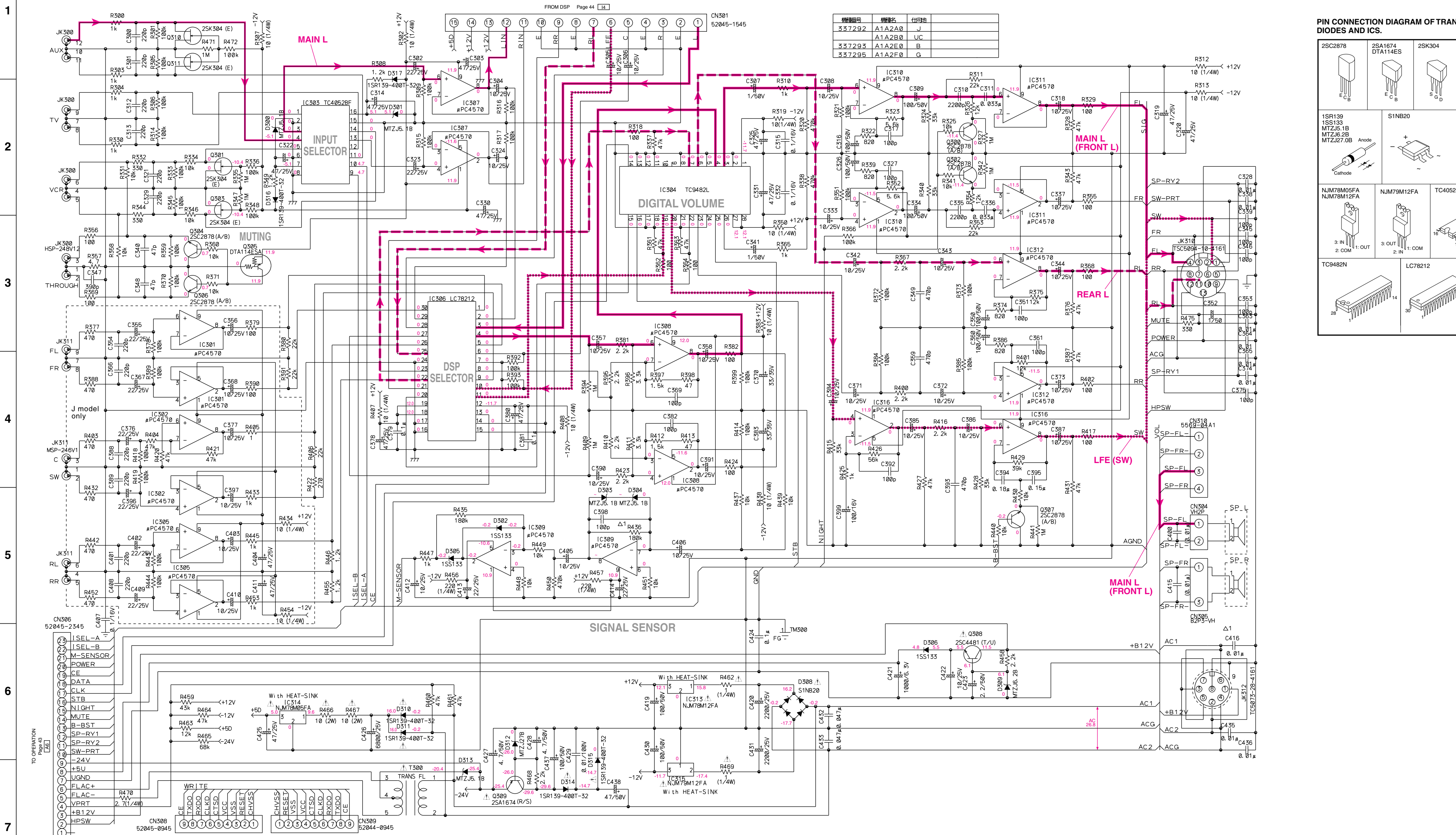

部品番号	部品名	仕向け
337292	A1A2A0	J
337293	A1A2B0	UC
337294	A1A2E0	B
337295	A1A2F0	G

PIN CONNECTION DIAGRAM OF TRANSISTORS, DIODES AND ICs.

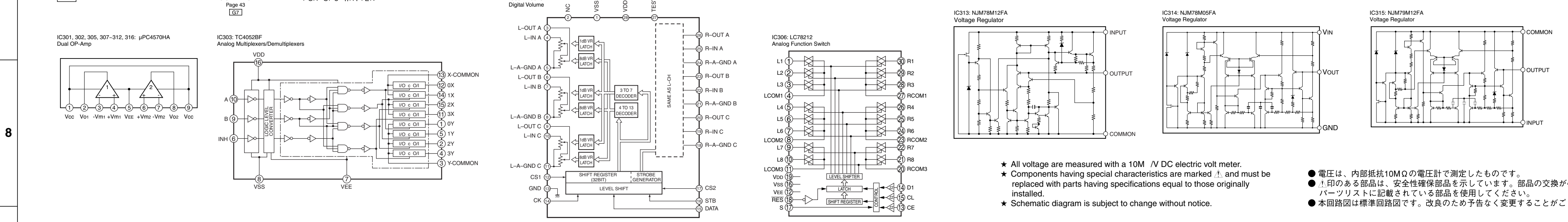
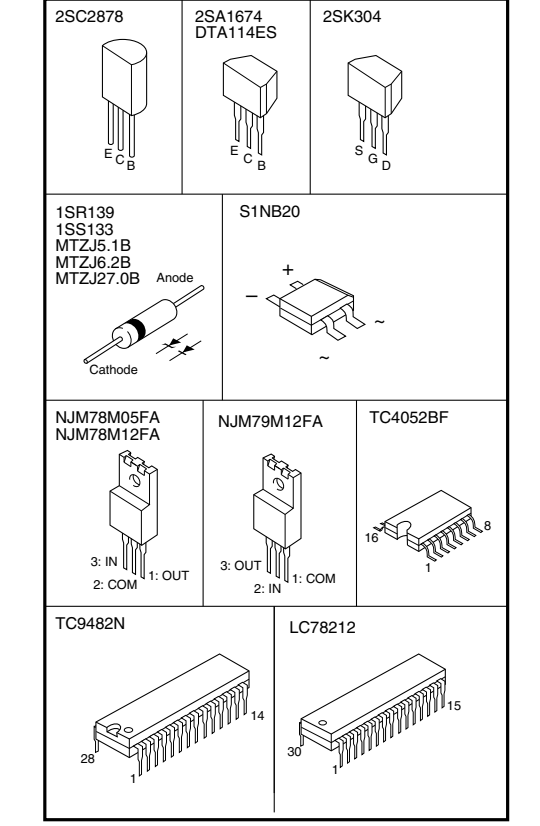

- ★ All voltage are measured with a 10M Ω/V DC electric volt meter.
- ★ Components having special characteristics are marked with a triangle (▲) and must be replaced with parts having specifications equal to those originally installed.
- ★ Schematic diagram is subject to change without notice.
- 電圧は、内部抵抗10MΩの電圧計で測定したものです。
- ▲印のある部品は、安全性確保部品を示しています。部品の交換が必要な場合、パーツリストに記載されている部品を使用してください。
- 本回路図は標準回路図です。改良のため予告なく変更することがございます。

AV-S77
AV-S77C SCHEMATIC DIAGRAM (OPERATION)

R204 (S11)	
A1A2A0 (J)	51K
A1A2E0 (B)	2K
A1A2F0 (G)	2K

PWB NO. 4192B

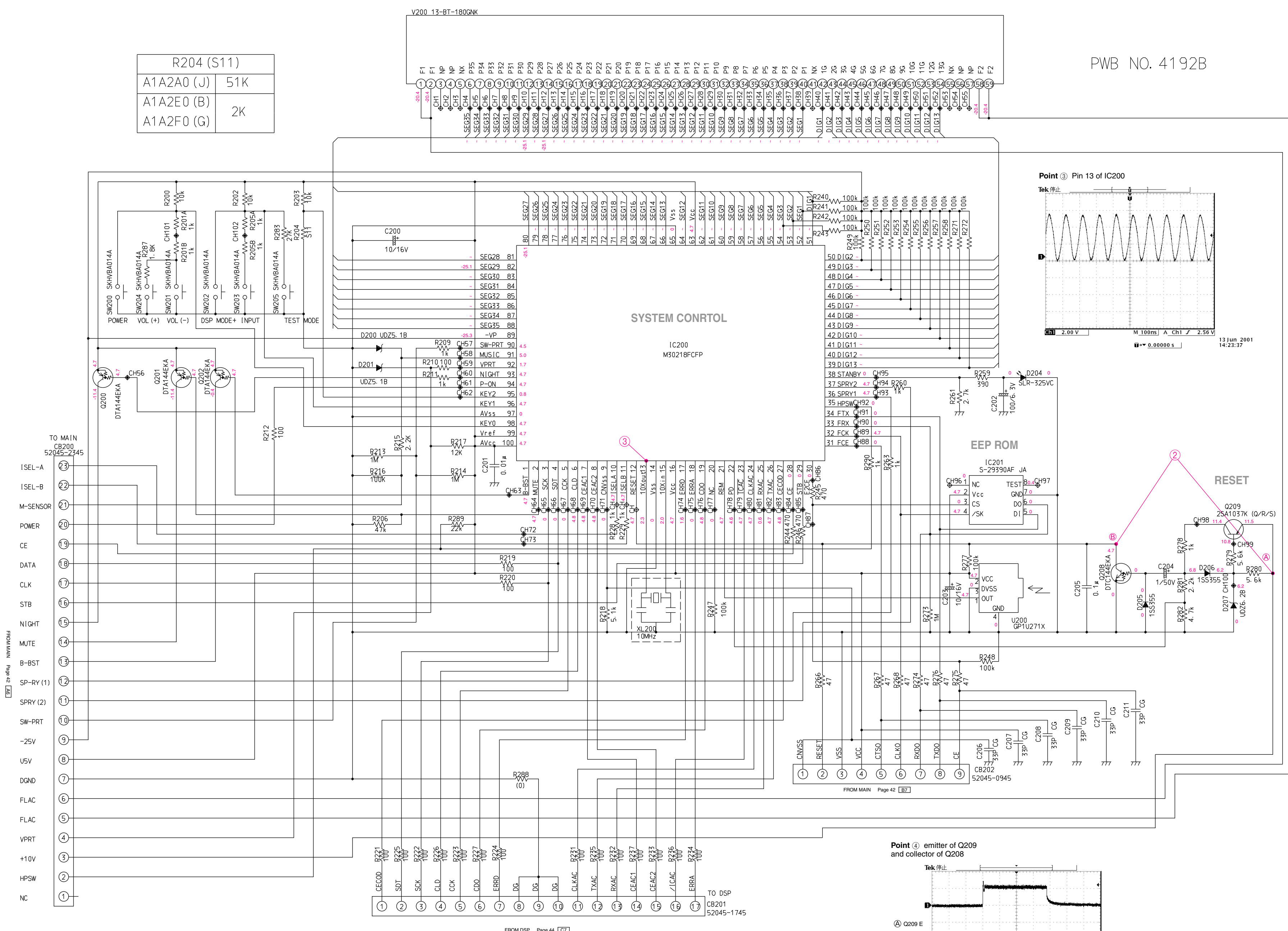
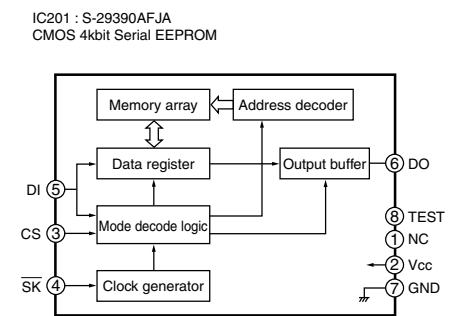

Point ③ Pin 13 of IC200

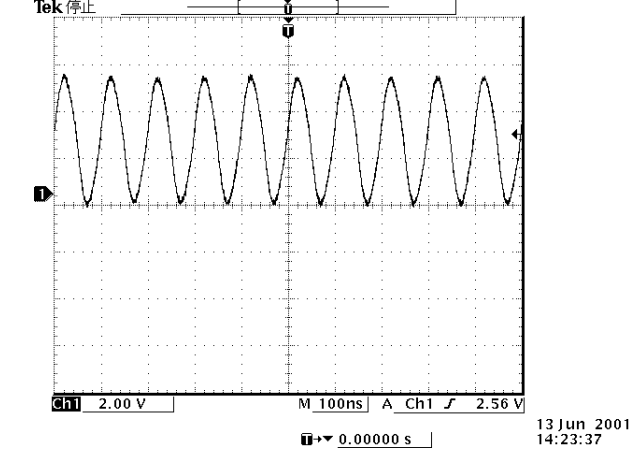

Point ④ emitter of Q209 and collector of Q208

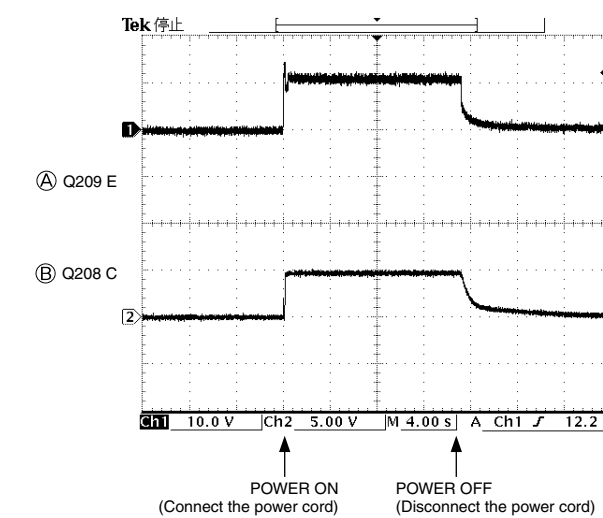

PIN CONNECTION DIAGRAM OF TRANSISTORS, DIODES AND ICs.

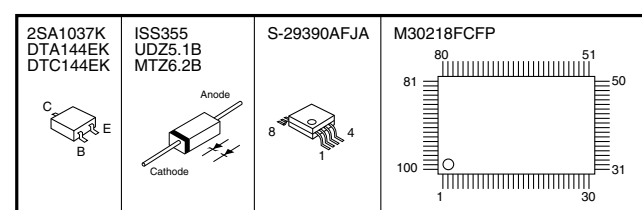

- ★ All voltage are measured with a 10M Ω DC electric volt meter.
- ★ Components having special characteristics are marked Δ and must be replaced with parts having specifications equal to those originally installed.
- ★ Schematic diagram is subject to change without notice.
- 電圧は、内部抵抗10M Ω の電圧計で測定したものです。
- Δ 印のある部品は、安全性確保部品を示しています。部品の交換が必要な場合、パーツリストに記載されている部品を使用してください。
- 本回路図は標準回路図です。改良のため予告なく変更することがございます。

AV-S77C SCHEMATIC DIAGRAM (DSP)

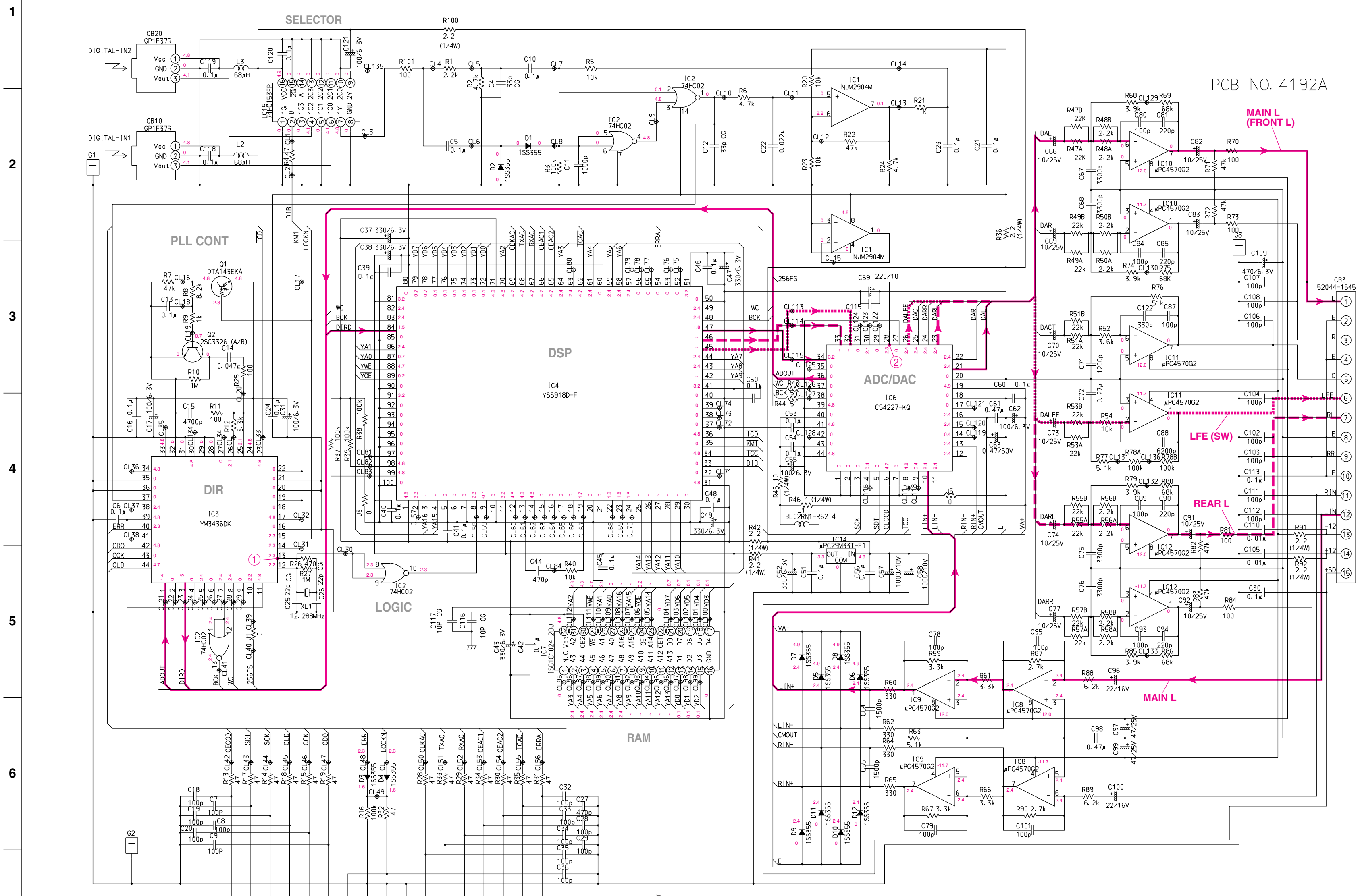

PCB NO. 4192A

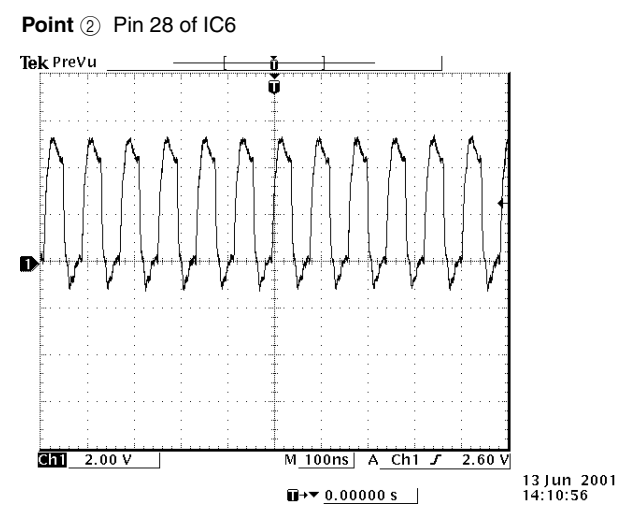
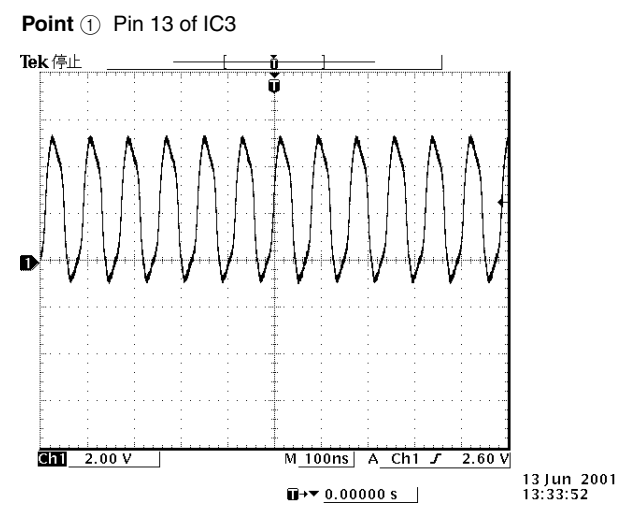

PIN CONNECTION DIAGRAM OF TRANSISTORS, DIODES AND ICs.

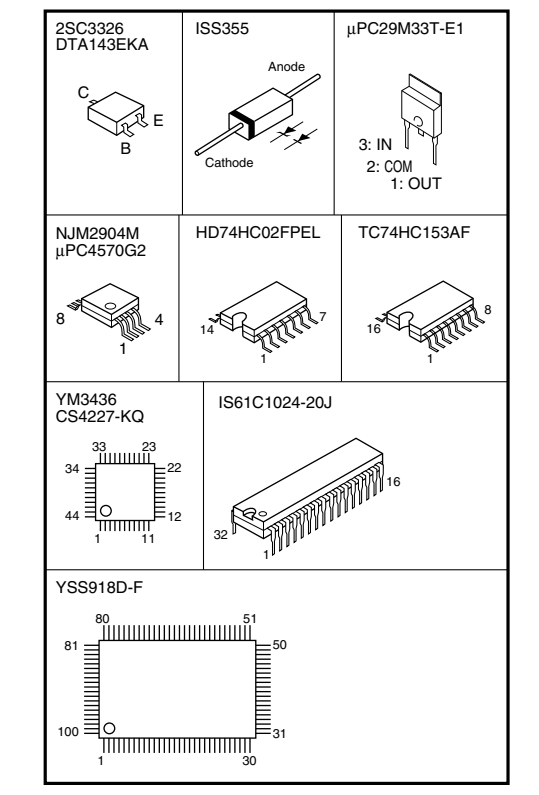

IC15: TC74HC153AF Dual 4-to-1 Data Selectors

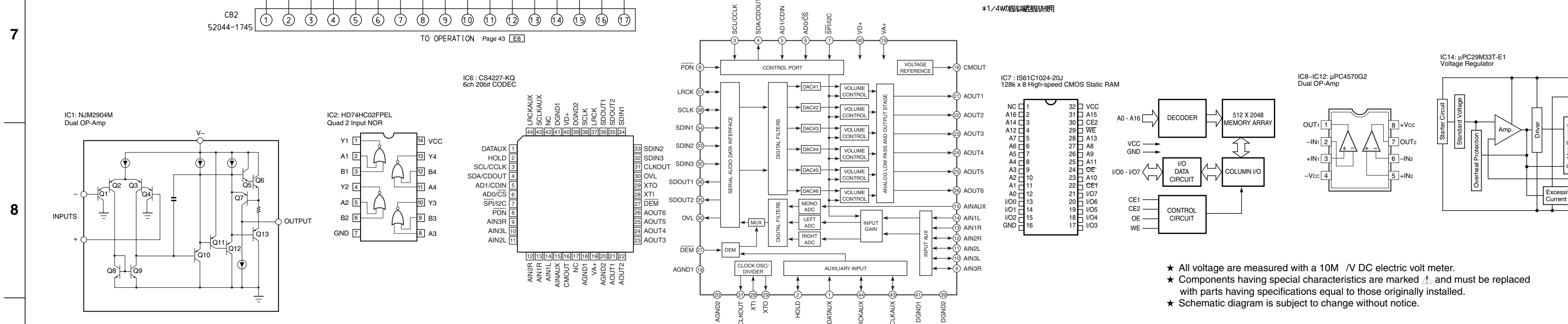
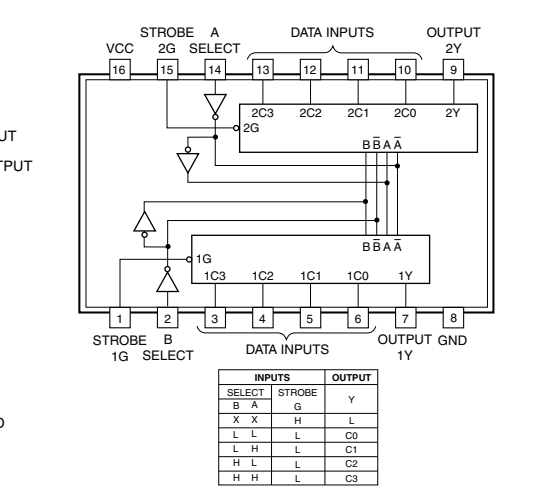

★ All voltage are measured with a 10M Ω/DC electric volt meter.
 ★ Components having special characteristics are marked with a triangle and must be replaced with parts having specifications equal to those originally installed.
 ★ Schematic diagram is subject to change without notice.

● 電圧は、内部抵抗10MΩの電圧計で測定したものです。
 ● 印のある部品は、安全性確保部品を示しています。部品の交換が必要な場合、パーツリストに記載されている部品を使用してください。
 ● 本回路図は標準回路図です。改良のため予告なく変更することがございます。

AV-S77
■ NX-SW77 SCHEMATIC DIAGRAM (AMP)

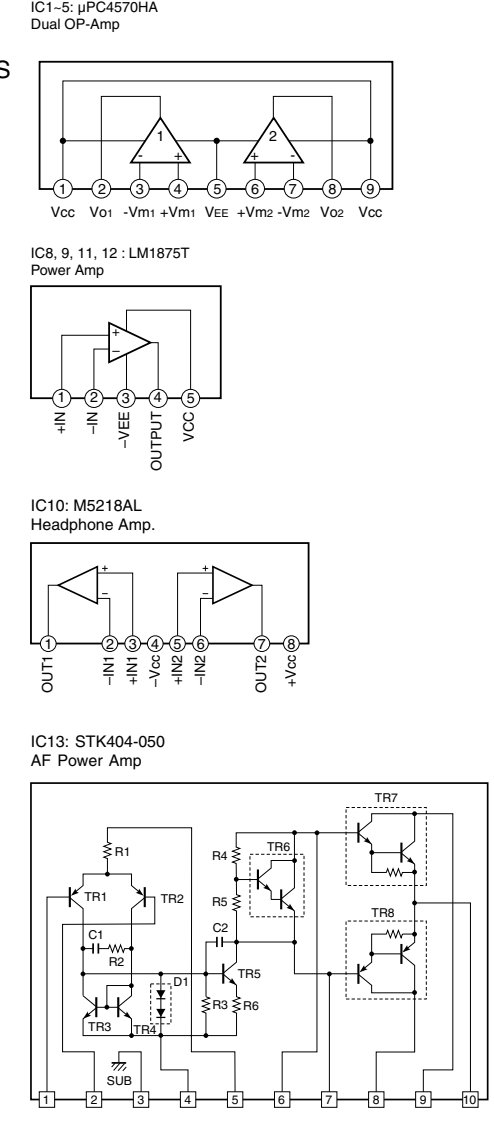
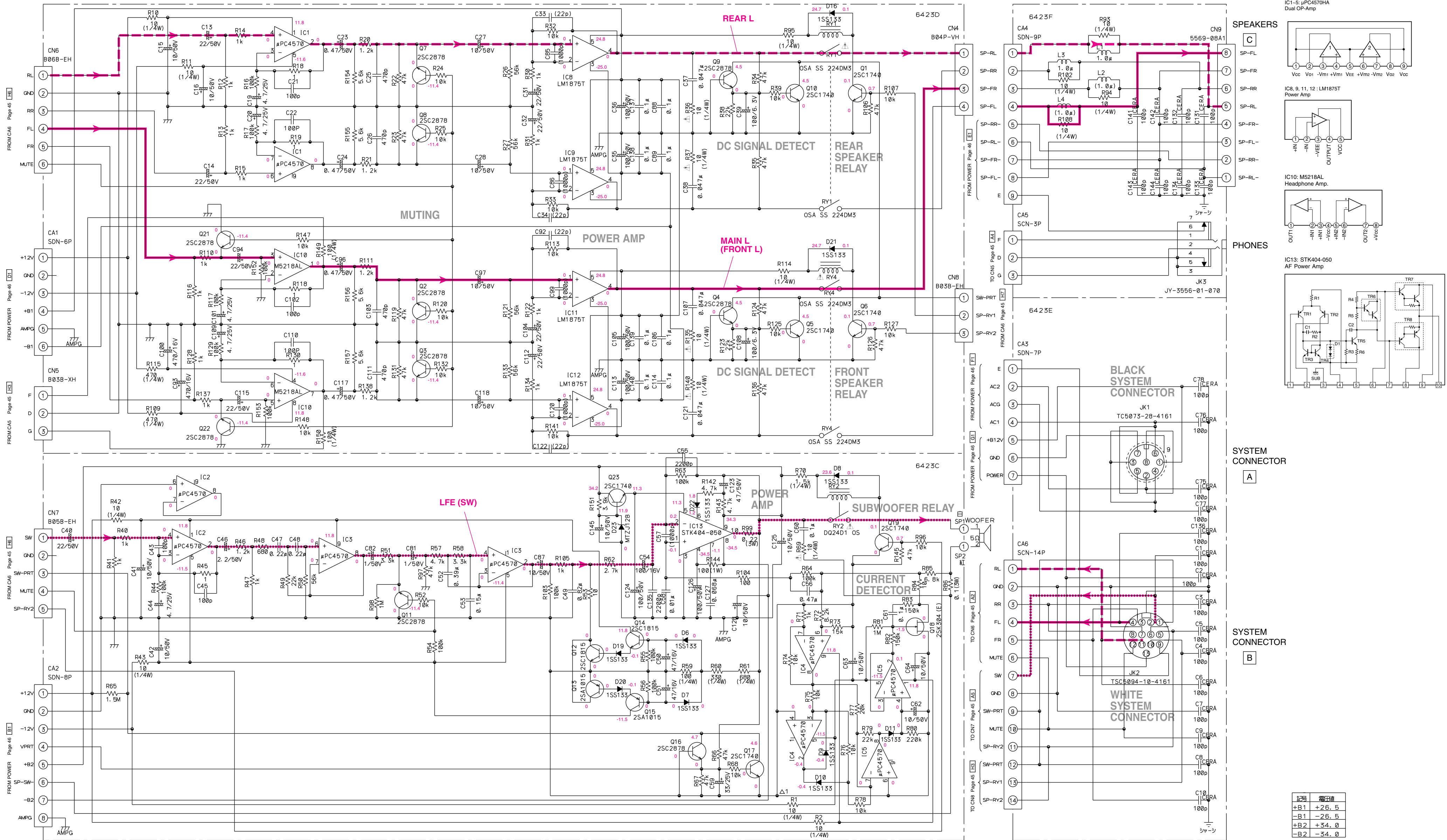

注: 電解コンデンサ以外の指定無しコンデンサはすべてフィルムコンデンサを使用。
 指定の無い抵抗はすべてカーボン抵抗 (1/6W type) を使用。
 容量の単位は、コンデンサ F (ファッド)、抵抗 Ω (オーム) を使用。
 IC8, 9, 11, 12, 13はヒートシンクに取り付ける。
 定数が () 裏記号はMOUNTしない。

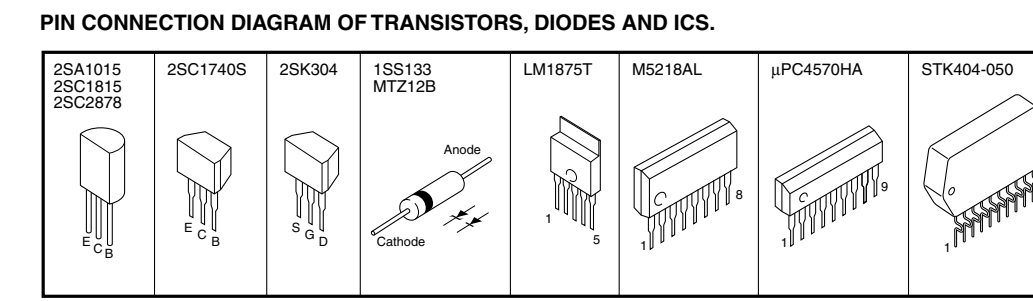

- ★ All voltage are measured with a 10M Ω /V DC electric volt meter.
- ★ Components having special characteristics are marked Δ and must be replaced with parts having specifications equal to those originally installed.
- ★ Schematic diagram is subject to change without notice.
- 電圧は、内部抵抗10MΩの電圧計で測定したものです。
- Δ 印のある部品は、安全性確保部品を示しています。部品の交換が必要な場合、パーツリストに記載されている部品を使用してください。
- 本回路図は標準回路図です。改良のため予告なく変更することがございます。

記号	電圧値
+B1	+26.5
-B1	-26.5
+B2	+34.0
-B2	-34.0

NX-SW77 SCHEMATIC DIAGRAM (POWER)

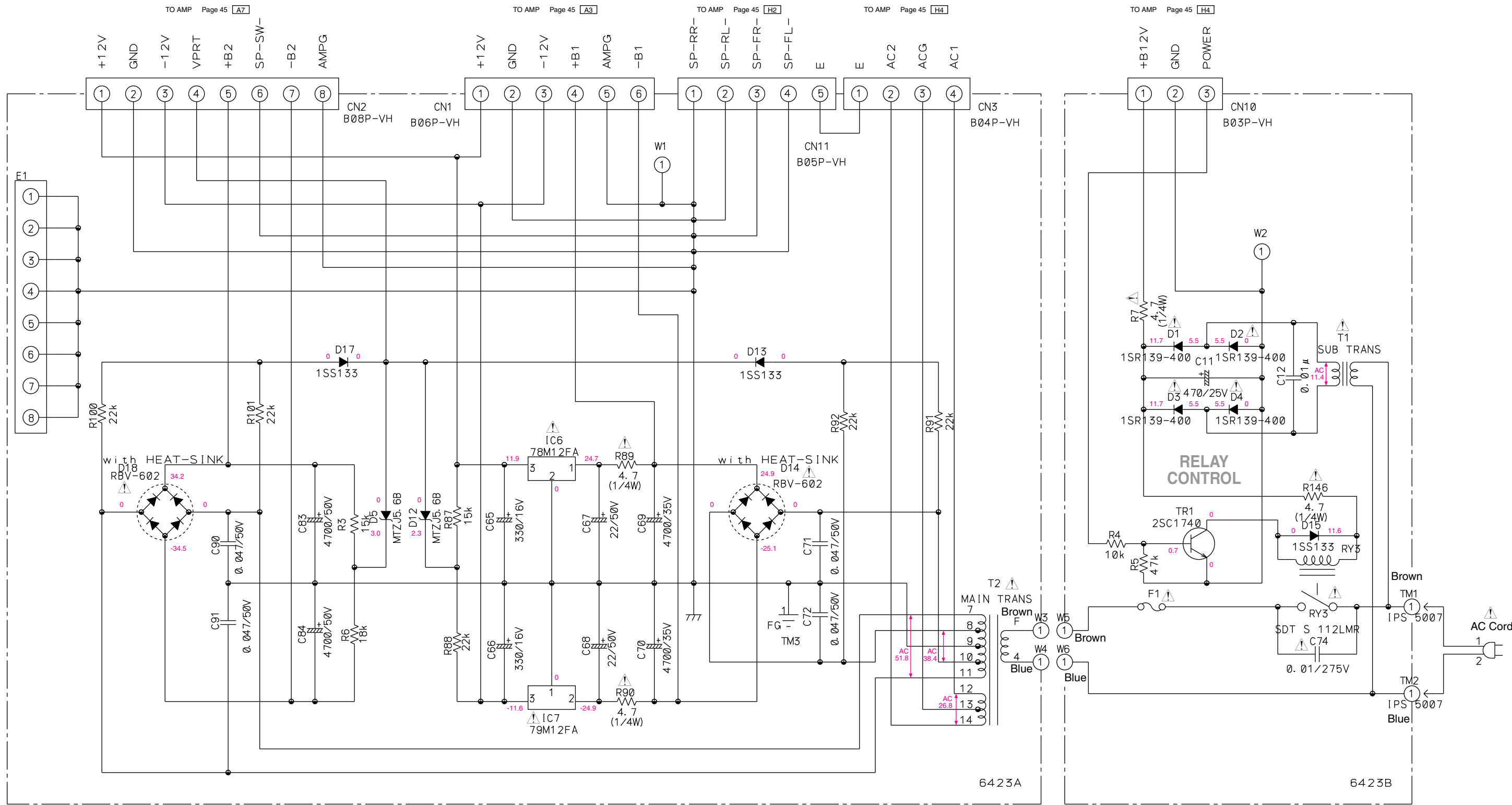

注：電解コンデンサ以外の指定のないコンデンサはすべてフィルムコンデンサ。
 指定のない抵抗はすべてカーボン抵抗 (1/6W) を使用。
 容量の単位は、コンデンサ F (ファラッド)、抵抗 Ω (オーム)。

Mark	Voltage	Model	T2	T1	F1	AC Cord	
+B1	+26.5	A1A1A0	J	337191	337194	F3. 15A125V	076126
-B1	-26.5	A1A1B0	UC				
+B2	+34.0	A1A1D0	A				
-B2	-34.0	A1A1E0	B	337192	337195	T1. 25AL250V	055284
		A1A1F0	G	337192	337195	T1. 25AL250V	076128

PIN CONNECTION DIAGRAM OF TRANSISTORS, DIODES AND ICs.

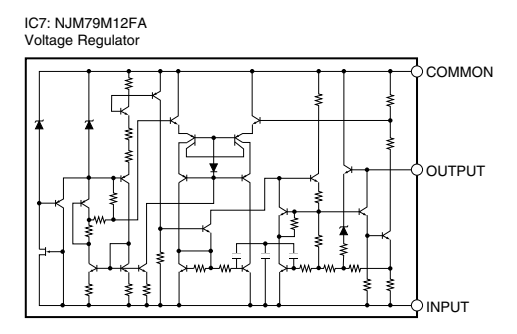
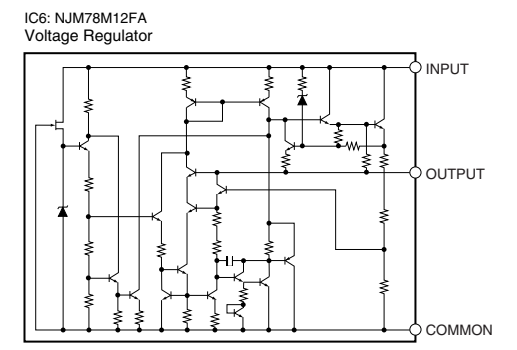
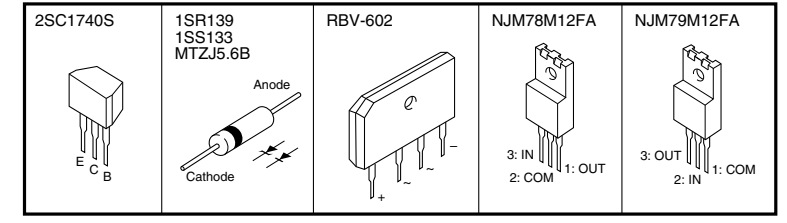

- ★ All voltage are measured with a 10M Ω DC electric volt meter.
- ★ Components having special characteristics are marked with a triangle symbol and must be replaced with parts having specifications equal to those originally installed.
- ★ Schematic diagram is subject to change without notice.

- 電圧は、内部抵抗10MΩの電圧計で測定したものです。
- 印のある部品は、安全性確保部品を示しています。部品の交換が必要な場合、パーツリストに記載されている部品を使用してください。
- 本回路図は標準回路図です。改良のため予告なく変更することがございます。

1
2
3
4
5
6
7
8
9

PARTS LIST

■ ELECTRICAL PARTS

■ WARNING

Components having special characteristics are marked Δ and must be replaced with parts having specifications equal to those originally installed.

- Carbon resistors (1/6W or 1/4W) are not included in the ELECTRICAL PARTS List. For the parts No. of the carbon resistors, refer to last page.

ABBREVIATIONS IN THIS LIST ARE AS FOLLOWS:

C.A.EL.CHP	: CHIP ALUMI.ELECTROLYTIC CAP	L.EMIT	: LIGHT EMITTING MODULE
C.CE	: CERAMIC CAP	LED.DSPLY	: LED DISPLAY
C.CE.ARRAY	: CERAMIC CAP ARRAY	LED.INFRD	: LED,INFRARED
C.CE.CHP	: CHIP CERAMIC CAP	MODUL.RF	: MODULATOR,RF
C.CE.ML	: MULTILAYER CERAMIC CAP	PHOT.CPL	: PHOTO COUPLER
C.CE.M.CHP	: CHIP MULTILAYER CERAMIC CAP	PHOT.INTR	: PHOTO INTERRUPTER
C.CE.SAFTY	: RECOGNIZED CERAMIC CAP	PHOT.RFLCT	: PHOTO REFLECTOR
C.CE.TUBLR	: CERAMIC TUBULAR CAP	PIN.TEST	: PIN,TEST POINT
C.CE.SMI	: SEMI CONDUCTIVE CERAMIC CAP	PLST.RIVET	: PLASTIC RIVET
C.EL	: ELECTROLYTIC CAP	R.ARRAY	: RESISTOR ARRAY
C.MICA	: MICA CAP	R.CAR.	: CARBON RESISTOR
C.ML.FLM	: MULTILAYER FILM CAP	R.CAR.CHP	: CHIP RESISTOR
C.MP	: METALLIZED PAPER CAP	R.CAR.FP	: FLAME PROOF CARBON RESISTOR
C.MYLAR	: MYLAR FILM CAP	R.FUS	: FUSABLE RESISTOR
C.MYLAR.ML	: MULTILAYER MYLAR FILM CAP	R.MTL.CHP	: CHIP METAL FILM RESISTOR
C.PAPER	: PAPER CAPACITOR	R.MTL.FLM	: METAL FILM RESISTOR
C.PLS	: POLYSTYRENE FILM CAP	R.MTL.OXD	: METAL OXIDE FILM RESISTOR
C.POL	: POLYESTER FILM CAP	R.MTL.PLAT	: METAL PLATE RESISTOR
C.POLY	: POLYETHYLENE FILM CAP	RSNR.CE	: CERAMIC RESONATOR
C.PP	: POLYPROPYLENE FILM CAP	RSNR.CRYS	: CRYSTAL RESONATOR
C.TNTL	: TANTALUM CAP	R.TW.CEM	: TWIN CEMENT FIXED RESISTOR
C.TNTL.CHP	: CHIP TANTALUM CAP	R.WW	: WIRE WOUND RESISTOR
C.TRIM	: TRIMMER CAP	SCR.BND.HD	: BIND HEAD B-TITE SCREW
CN	: CONNECTOR	SCR.BW.HD	: BW HEAD TAPPING SCREW
CN.BS.PIN	: CONNECTOR,BASE PIN	SCR.CUP	: CUP TITE SCREW
CN.CANNON	: CONNECTOR,CANNON	SCR.TERM	: SCREW TERMINAL
CN.DIN	: CONNECTOR,DIN	SCR.TR	: SCREW,TRANSISTOR
CN.FLAT	: CONNECTOR,FLAT CABLE	SUPRT.PCB	: SUPPORT,P.C.B.
CN.POST	: CONNECTOR,BASE POST	SURG.PRTCT	: SURGE PROTECTOR
COIL.MX.AM	: COIL,AM MIX	SW.TACT	: TACT SWITCH
COIL.AT.FM	: COIL,FM ANTENNA	SW.LEAF	: LEAF SWITCH
COIL.DT.FM	: COIL,FM DETECT	SW.LEVER	: LEVER SWITCH
COIL.MX.FM	: COIL,FM MIX	SW.MICRO	: MICRO SWITCH
COIL.OUTPT	: OUTPUT COIL	SW.PUSH	: PUSH SWITCH
DIOD.ARRAY	: DIODE ARRAY	SW.RT.ENC	: ROTARY ENCODER
DIODE.BRG	: DIODE BRIDGE	SW.RT.MTR	: ROTARY SWITCH WITH MOTOR
DIODE.CHP	: CHIP DIODE	SW.RT	: ROTARY SWITCH
DIODE.SHOT	: SCHOTTKY BARRIER DIODE	SW.SLIDE	: SLIDE SWITCH
DIODE.VAR	: VARACTOR DIODE	TERM.SP	: SPEAKER TERMINAL
DIOD.Z.CHP	: CHIP ZENER DIODE	TERM.WRAP	: WRAPPING TERMINAL
DIODE.ZENR	: ZENER DIODE	THRMST.CHP	: CHIP THERMISTOR
DSCR.CE	: CERAMIC DISCRIMINATOR	TR.CHP	: CHIP TRANSISTOR
FER.BEAD	: FERRITE BEADS	TR.DGT	: DIGITAL TRANSISTOR
FER.CORE	: FERRITE CORE	TR.DGT.CHP	: CHIP DIGITAL TRANSISTOR
FET.CHP	: CHIP FET	TRANS	: TRANSFORMER
FL.DSPLY	: FLUORESCENT DISPLAY	TRANS.PULS	: PULSE TRANSFORMER
FLTR.CE	: CERAMIC FILTER	TRANS.PWR	: POWER TRANSFORMER ASS'Y
FLTR.COMB	: COMB FILTER MODULE	TUNER.AM	: TUNER PACK,AM
FLTR.LC.RF	: LC FILTER,EMI	TUNER.FM	: TUNER PACK,FM
GND.MTL	: GROUND PLATE	TUNER.PK	: FRONT-END TUNER PACK
GND.TERM	: GROUND TERMINAL	VR	: ROTARY POTENTIOMETER
HOLDER.FUS	: FUSE HOLDER	VR.MTR	: POTENTIOMETER WITH MOTOR
IC.PRTCT	: IC PROTECTOR	VR.SW	: POTENTIOMETER WITH ROTARY SW
JUMPER.CN	: JUMPER CONNECTOR	VR.SLIDE	: SLIDE POTENTIOMETER
JUMPER.TST	: JUMPER,TEST POINT	VR.TRIM	: TRIMMER POTENTIOMETER
L.DTCT	: LIGHT DETECTING MODULE		

Note) Those parts marked with “#” are not included in the P.C.B. ass'y.

AV-S77C P.C.B. AMP & P.C.B. DSP-FL

Schm Ref.	PART NO.	Description	Remarks
	AAX28220	P. C. B.	339148
	AAX28200	P. C. B.	338951
C04	US061330	C. CE. CHP 33pF 50V	065487
C05	US145100	C. CE. CHP 0.1uF 25V	065469
C06	US145100	C. CE. CHP 0.1uF 25V	065469
C07	US062100	C. CE. CHP 100pF 50V	065500
C08	US062100	C. CE. CHP 100pF 50V	065500
C09	US062100	C. CE. CHP 100pF 50V	065500
C10	US145100	C. CE. CHP 0.1uF 25V	065469
C11	US063100	C. CE. CHP 1000pF 50V	065501
C12	US061330	C. CE. CHP 33pF 50V	065487
C13	US145100	C. CE. CHP 0.1uF 25V	065469
C14	AAX11280	C. POL 0.047uF 50V	065118
C15	AAX11270	C. POL 4700pF 50V	065111
C16	US145100	C. CE. CHP 0.1uF 25V	065469
C17	AAX10170	C. EL 100uF 6.3V	066296
C18	US062100	C. CE. CHP 100pF 50V	065500
C19	US062100	C. CE. CHP 100pF 50V	065500
C20	US062100	C. CE. CHP 100pF 50V	065500
C21	US145100	C. CE. CHP 0.1uF 25V	065469
C22	US044220	C. CE. CHP 0.022uF 25V	065555
C23	US145100	C. CE. CHP 0.1uF 25V	065469
C24	US145100	C. CE. CHP 0.1uF 25V	065469
C25	US061220	C. CE. CHP 22pF 50V	065483
C26	US061220	C. CE. CHP 22pF 50V	065483
C27	US062100	C. CE. CHP 100pF 50V	065500
C28	US062100	C. CE. CHP 100pF 50V	065500
C29	US062100	C. CE. CHP 100pF 50V	065500
C30	US145100	C. CE. CHP 0.1uF 25V	065469
C31	AAX10170	C. EL 100uF 6.3V	066296
C32	US062100	C. CE. CHP 100pF 50V	065500
C33	US062100	C. CE. CHP 100pF 50V	065500
C34	US062100	C. CE. CHP 100pF 50V	065500
C35	US062100	C. CE. CHP 100pF 50V	065500
C36	US062100	C. CE. CHP 100pF 50V	065500
C37	AAX10310	C. EL 330uF 6.3V	066397
C38	AAX10310	C. EL 330uF 6.3V	066397
C39	US145100	C. CE. CHP 0.1uF 25V	065469
C40	US145100	C. CE. CHP 0.1uF 25V	065469
C41	US145100	C. CE. CHP 0.1uF 25V	065469
C42	US145100	C. CE. CHP 0.1uF 25V	065469
C43	AAX10310	C. EL 330uF 6.3V	066397
C44	US062470	C. CE. CHP 470pF 50V	065514
C45	US145100	C. CE. CHP 0.1uF 25V	065469
C46	US145100	C. CE. CHP 0.1uF 25V	065469
C47	AAX10310	C. EL 330uF 6.3V	066397
C48	US145100	C. CE. CHP 0.1uF 25V	065469
C49	AAX10310	C. EL 330uF 6.3V	066397
C50	US145100	C. CE. CHP 0.1uF 25V	065469
C51	US145100	C. CE. CHP 0.1uF 25V	065469
C52	AAX10310	C. EL 330uF 6.3V	066397
C53	US145100	C. CE. CHP 0.1uF 25V	065469
C54	US145100	C. CE. CHP 0.1uF 25V	065469
C55	AAX10170	C. EL 100uF 6.3V	066296
C56	US145100	C. CE. CHP 0.1uF 25V	065469
C57	AAX10230	C. EL 1000uF 10V	066316
C58	AAX10230	C. EL 1000uF 10V	066316
C59	AAX10280	C. EL 220uF 10V	066359
C60	US145100	C. CE. CHP 0.1uF 25V	065469
C61	AAX11170	C. POL 0.47uF 50V	064936
C62	AAX10170	C. EL 100uF 6.3V	066296
C63	AAX10400	C. EL 0.47uF 50V	066462
C64	AAX11210	C. POL 1500pF 50V	065028

* New Parts

Schm Ref.	PART NO.	Description	Remarks
C65	AAX11210	C. POL 1500pF 50V	065028
C66	AAX10160	C. EL 10uF 25V	066286
C67	AAX11240	C. POL 3300pF 50V	065087
C68	AAX11240	C. POL 3300pF 50V	065087
C69	AAX10160	C. EL 10uF 25V	066286
C70	AAX10160	C. EL 10uF 25V	066286
C71	AAX11190	C. POL 1200pF 50V	065014
C72	AAX11230	C. POL 0.27uF 50V	065082
C73	AAX10160	C. EL 10uF 25V	066286
C74	AAX10160	C. EL 10uF 25V	066286
C75	AAX11240	C. POL 3300pF 50V	065087
C76	AAX11240	C. POL 3300pF 50V	065087
C77	AAX10160	C. EL 10uF 25V	066286
C78	UA652100	C. MYLAR 100pF 50V	
C79	UA652100	C. MYLAR 100pF 50V	
C80	UA652100	C. MYLAR 100pF 50V	
C81	AAX11130	C. POL 220pF 50V	055447
C82	AAX10160	C. EL 10uF 25V	066286
C83	AAX10160	C. EL 10uF 25V	066286
C84	UA652100	C. MYLAR 100pF 50V	
C85	AAX11130	C. POL 220pF 50V	055447
C87	UA652100	C. MYLAR 100pF 50V	
C88	AAX11140	C. POL 6200pF 50V	055501
C89	UA652100	C. MYLAR 100pF 50V	
C90	AAX11130	C. POL 220pF 50V	055447
C91	AAX10160	C. EL 10uF 25V	066286
C92	AAX10160	C. EL 10uF 25V	066286
C93	UA652100	C. MYLAR 100pF 50V	
C94	AAX11130	C. POL 220pF 50V	055447
C95	UA652100	C. MYLAR 100pF 50V	
C96	AAX10260	C. EL 22uF 16V	066345
C97	AAX10320	C. EL 47uF 25V	066428
C98	AAX11170	C. POL 0.47uF 50V	064936
C99	AAX10320	C. EL 47uF 25V	066428
C100	AAX10260	C. EL 22uF 16V	066345
C101	UA652100	C. MYLAR 100pF 50V	
C102	US062100	C. CE. CHP 100pF 50V	065500
C103	US062100	C. CE. CHP 100pF 50V	065500
C104	US062100	C. CE. CHP 100pF 50V	065500
C105	US064100	C. CE. CHP 0.01uF 50V	065502
C106	US062100	C. CE. CHP 100pF 50V	065500
C107	US062100	C. CE. CHP 100pF 50V	065500
C108	US062100	C. CE. CHP 100pF 50V	065500
C109	AAX10350	C. EL 470uF 6.3V	066436
C110	US064100	C. CE. CHP 0.01uF 50V	065502
C111	US062100	C. CE. CHP 100pF 50V	065500
C112	US062100	C. CE. CHP 100pF 50V	065500
C113	US145100	C. CE. CHP 0.1uF 25V	065469
C116	US061100	C. CE. CHP 10pF 50V	065472
C117	US061100	C. CE. CHP 10pF 50V	065472
C118	US145100	C. CE. CHP 0.1uF 25V	065469
C119	US145100	C. CE. CHP 0.1uF 25V	065469
C120	US145100	C. CE. CHP 0.1uF 25V	065469
C121	AAX10170	C. EL 100uF 6.3V	066296
C122	AAX11110	C. POL 330pF 50V	050158
C200	AAX10420	C. EL 10uF 16V	066763
C201	US064100	C. CE. CHP 0.01uF 50V	065502
C202	AAX10440	C. EL 100uF 6.3V	066774
C203	AAX10420	C. EL 10uF 16V	066763
C204	AAX10460	C. EL 1uF 50V	066783
C205	US145100	C. CE. CHP 0.1uF 25V	065469
C206	US061330	C. CE. CHP 33pF 50V	065487
C207	US061330	C. CE. CHP 33pF 50V	065487

* New Parts

AV-S77C P.C.B. AMP & P.C.B. DSP-FL

Schm Ref.	PART NO.	Description	Remarks
C208	US061330	C.CE.CHP 33pF 50V	065487
C209	US061330	C.CE.CHP 33pF 50V	065487
C210	US061330	C.CE.CHP 33pF 50V	065487
C211	US061330	C.CE.CHP 33pF 50V	065487
C300	FG212220	C.CE 220pF 50V	085034
C301	FG212220	C.CE 220pF 50V	085034
C302	AAX10270	C.EL 22uF 25V	066347
C303	AAX10320	C.EL 47uF 25V	066428
C304	AAX10160	C.EL 10uF 25V	066286
C305	AAX10160	C.EL 10uF 25V	066286
C306	AAX10160	C.EL 10uF 25V	066286
C307	AAX10240	C.EL 1uF 50V	066329
C308	AAX10160	C.EL 10uF 25V	066286
C309	AAX10210	C.EL 100uF 50V	066311
C310	XX707850	C.POL 0.0022uF 50V	065055
C311	AAX11250	C.POL 0.033uF 50V	065092
C312	FG212220	C.CE 220pF 50V	085034
C313	FG212220	C.CE 220pF 50V	085034
C314	AAX10320	C.EL 47uF 25V	066428
C315	FG245100	C.CE 0.1uF 50V	336369
C316	AAX10210	C.EL 100uF 50V	066311
C317	FG212100	C.CE 100pF 50V	065904
C318	AAX10160	C.EL 10uF 25V	066286
C319	AAX10320	C.EL 47uF 25V	066428
C320	AAX10320	C.EL 47uF 25V	066428
C321	FG212220	C.CE 220pF 50V	085034
C322	AAX10320	C.EL 47uF 25V	066428
C323	AAX10270	C.EL 22uF 25V	066347
C324	AAX10160	C.EL 10uF 25V	066286
C325	AAX10320	C.EL 47uF 25V	066428
C326	AAX10210	C.EL 100uF 50V	066311
C327	FG212100	C.CE 100pF 50V	065904
C328	AAX09970	C.CE 0.01uF 50V	049191
C329	FG212220	C.CE 220pF 50V	085034
C330	AAX10320	C.EL 47uF 25V	066428
C331	AAX10320	C.EL 47uF 25V	066428
C332	FG245100	C.CE 0.1uF 50V	336369
C333	AAX10160	C.EL 10uF 25V	066286
C334	AAX10210	C.EL 100uF 50V	066311
C335	XX707850	C.POL 0.0022uF 50V	065055
C336	AAX11250	C.POL 0.033uF 50V	065092
C337	AAX10160	C.EL 10uF 25V	066286
C338	AAX09970	C.CE 0.01uF 50V	049191
C339	FG212100	C.CE 100pF 50V	065904
C340	FG211470	C.CE 47pF 50V	085035
C341	AAX10240	C.EL 1uF 50V	066329
C342	AAX10160	C.EL 10uF 25V	066286
C343	AAX10160	C.EL 10uF 25V	066286
C344	AAX10160	C.EL 10uF 25V	066286
C345	FG212100	C.CE 100pF 50V	065904
C346	FG212100	C.CE 100pF 50V	065904
C347	FG212390	C.CE 390pF 50V	049194
C348	FG211470	C.CE 47pF 50V	085035
C349	FG212470	C.CE 470pF 50V	332145
C350	AAX10210	C.EL 100uF 50V	066311
C351	FG212100	C.CE 100pF 50V	065904
C353	FG212100	C.CE 100pF 50V	065904
C357	AAX10160	C.EL 10uF 25V	066286
C358	AAX10160	C.EL 10uF 25V	066286
C359	FG212470	C.CE 470pF 50V	332145
C360	AAX10210	C.EL 100uF 50V	066311
C361	FG212100	C.CE 100pF 50V	065904
C363	AAX09970	C.CE 0.01uF 50V	049191

* New Parts

Schm Ref.	PART NO.	Description	Remarks
C364	AAX09970	C.CE 0.01uF 50V	049191
C365	AAX09970	C.CE 0.01uF 50V	049191
C369	FG212100	C.CE 100pF 50V	065904
C370	UR857330	C.EL 33uF 35V	066393
C371	AAX10160	C.EL 10uF 25V	066286
C372	AAX10160	C.EL 10uF 25V	066286
C373	AAX10160	C.EL 10uF 25V	066286
C374	AAX09970	C.CE 0.01uF 50V	049191
C375	FG212100	C.CE 100pF 50V	065904
C378	AAX10320	C.EL 47uF 25V	066428
C379	FG245100	C.CE 0.1uF 50V	336369
C380	AAX10320	C.EL 47uF 25V	066428
C381	FG245100	C.CE 0.1uF 50V	336369
C382	FG212100	C.CE 100pF 50V	065904
C383	UR857330	C.EL 33uF 35V	066393
C384	AAX10160	C.EL 10uF 25V	066286
C385	AAX10160	C.EL 10uF 25V	066286
C386	AAX10160	C.EL 10uF 25V	066286
C387	AAX10160	C.EL 10uF 25V	066286
C390	AAX10160	C.EL 10uF 25V	066286
C391	AAX10160	C.EL 10uF 25V	066286
C392	FG212100	C.CE 100pF 50V	065904
C393	FG212470	C.CE 470pF 50V	332145
C394	AAX12410	C.POL 0.18uF 50V	064917
C395	AAX11160	C.POL 0.15uF 50V	064914
C398	FG212100	C.CE 100pF 50V	065904
C399	AAX10190	C.EL 100uF 6.3V	066302
C405	AAX10160	C.EL 10uF 25V	066286
C406	AAX10160	C.EL 10uF 25V	066286
C407	FG245100	C.CE 0.1uF 50V	336369
C412	AAX10160	C.EL 10uF 25V	066286
C413	AAX10270	C.EL 22uF 25V	066347
C414	AAX10270	C.EL 22uF 25V	066347
C416	AAX09970	C.CE 0.01uF 50V	049191
C419	AAX10210	C.EL 100uF 50V	066311
C420	UR649220	C.EL 2200uF 25V	066372
C421	UR819100	C.EL 1000uF 6.3V	066314
C422	AAX10160	C.EL 10uF 25V	066286
C423	XX698300	C.EL 22uF 50V	066377
C425	AAX10320	C.EL 47uF 25V	066428
C426	UR749680	C.EL 6800uF 25V	066745
C427	AAX10390	C.EL 4.7uF 50V	066459
C428	AAX10390	C.EL 4.7uF 50V	066459
C429	XX698870	C.POL 0.01uF 50V	065000
C430	AAX10210	C.EL 100uF 50V	066311
C431	UR649220	C.EL 2200uF 25V	066372
C435	AAX09970	C.CE 0.01uF 50V	049191
C436	AAX09970	C.CE 0.01uF 50V	049191
C437	AAX10210	C.EL 100uF 50V	066311
C438	AAX10340	C.EL 47uF 50V	066432
CB2	VF982300	CN 52044-1745	055308
CB3	AAX28440	CN 52044-1545	338909
CB10	AAX28670	CN.PHOTO.S GP1FA550RZ	335200
CB20	AAX28670	CN.PHOTO.S GP1FA550RZ	335200
CB200	VM389000	CN 52045-2345	081830
CB201	AAX28450	CN 52045-1745	338910
CB202	VQ047200	CN 52045-09	055033
CN301	AAX28420	CN 52045-1545	338793
CN304	LB932020	CN.BS.PIN 2P	081661
CN305	AAX10590	CN B2P3-VH	081855
CN306	VM389000	CN 52045-2345	081830
CN308	VQ047200	CN 52045-09	055033
CN309	VQ044400	CN 52044-09	055032

* New Parts

AV-S77C P.C.B. AMP & P.C.B. DSP-FL

Schm Ref.	PART NO.	Description	Remarks
* CN310	AAX28400	CN	5569-04A1 BLK 081867
D1	XX698570	DIODE	ISS355 069444
D2	XX698570	DIODE	ISS355 069444
D3	XX698570	DIODE	ISS355 069444
D4	XX698570	DIODE	ISS355 069444
D5	XX698570	DIODE	ISS355 069444
D6	XX698570	DIODE	ISS355 069444
D7	XX698570	DIODE	ISS355 069444
D8	XX698570	DIODE	ISS355 069444
D9	XX698570	DIODE	ISS355 069444
D10	XX698570	DIODE	ISS355 069444
D11	XX698570	DIODE	ISS355 069444
D12	XX698570	DIODE	ISS355 069444
D200	VU171900	DIODE.ZENR	UDZ5.1B 048310
D201	VU171900	DIODE.ZENR	UDZ5.1B 048310
D204	VT439400	LED(re)	SLR-342VC RED 069822
D205	XX698570	DIODE	ISS355 069444
D206	XX698570	DIODE	ISS355 069444
D207	iF010740	DIODE.ZENR	MTZ6.2B 6.2V 044872
D300	VG437400	DIODE.ZENR	MTZJ5.1B 5.1V 069087
D301	VG437400	DIODE.ZENR	MTZJ5.1B 5.1V 069087
D302	iF004600	DIODE	1S133 069460
D303	VG437400	DIODE.ZENR	MTZJ5.1B 5.1V 069087
D304	VG437400	DIODE.ZENR	MTZJ5.1B 5.1V 069087
D305	iF004600	DIODE	1S133 069460
D306	iF004600	DIODE	1S133 069460
⚠ D308	VR253700	DIODE.BRG	S1NB20 1.0A 200V 338792
D309	iF010740	DIODE.ZENR	MTZ6.2B 6.2V 069107
⚠ D310	VU264100	DIODE	1SR139-400 069537
⚠ D311	VU264100	DIODE	1SR139-400 069537
D312	VG442900	DIODE.ZENR	MTZJ27B 27V 069228
D313	VG437400	DIODE.ZENR	MTZJ5.1B 5.1V 069087
⚠ D314	VU264100	DIODE	1SR139-400 069537
⚠ D315	VU264100	DIODE	1SR139-400 069537
G1	XX698880	LUG	MET37-0001 075878
G2	XX698880	LUG	MET37-0001 075878
G3	XX698880	LUG	MET37-0001 075878
IC1	XR038A00	IC	NJM2904M T1 070192
IC2	XL091A00	IC	HD74HC02FPPEL 055305
IC3	XG948E00	IC	YM3436 055299
IC4	XV304B00	IC	YSS918D-F 333302
IC6	XW233A00	IC	CS4227-KQ 44PIN 055320
IC7	XV305A00	IC	IS61C1024-20J SRAM 333322
IC8	XF291A00	IC	uPC4570G2 070173
IC9	XF291A00	IC	uPC4570G2 070173
IC10	XF291A00	IC	uPC4570G2 070173
IC11	XF291A00	IC	uPC4570G2 070173
IC12	XF291A00	IC	uPC4570G2 070173
IC14	XU965A00	IC	uPC29M33T-E1 055304
IC15	XR042A00	IC	TC74HC153AF 070781
* IC200	X2249A00	IC	M30217MA-A208FP
IC201	AAX10090	IC	S-29390AFJA TB 055306
IC303	XG903A00	IC	TC4052BF 070705
IC304	AAX10080	IC	TC9482N 055303
IC306	XP895A00	IC	LC78212 044954
IC307	XB247A00	IC	uPC4570HA 070111
IC308	XB247A00	IC	uPC4570HA 070111
IC309	XB247A00	IC	uPC4570HA 070111
IC310	XB247A00	IC	uPC4570HA 070111
IC311	XB247A00	IC	uPC4570HA 070111
IC312	XB247A00	IC	uPC4570HA 070111
⚠ IC313	AAX11990	IC	NJM78M12FA 070371
⚠ IC314	XJ604A00	IC	NJM78M05FA 070384

* New Parts

Schm Ref.	PART NO.	Description	Remarks
⚠ IC315	AAX12000	IC	NJM79M12FA 070447
IC316	XB247A00	IC	uPC4570HA 070111
* JK300	AAX28530	JACK.RCA	HSP-248V12-01 055460
* JK310	AAX28180	JACK.DIN	13P TCS5094-10-41 056981
* JK312	AAX28170	JACK.DIN	8P TC5073-28-4 056980
L1	GE300610	FER.CORE	L1 FERITE CORE BLO2RN 073729
L2	GE901970	COIL	CHK LAV35VB 680K 055508
L3	GE901970	COIL	CHK LAV35VB 680K 055508
Q1	VV655200	TR	DTA143EKA T146 055311
Q2	VD303700	TR	2SC3326 B TE85L 068835
Q200	XX698710	TR	DTA144EK 069270
Q201	XX698710	TR	DTA144EK 069270
Q202	XX698710	TR	DTA144EK 069270
Q208	XX698720	TR	DTC144EK 069311
Q209	VV556500	TR	2SA1037K QRS 068590
Q300	iC287820	TR	2SC2878 A,B 068813
Q301	AAX09180	FET	2SK304 E 051061
Q302	iC287820	TR	2SC2878 A,B 068813
Q303	AAX09180	FET	2SK304 E 051061
Q304	iC287820	TR	2SC2878 A,B 068813
Q305	VD678500	TR	DTA114ESA 069248
Q306	iC287820	TR	2SC2878 A,B 068813
Q307	iC287820	TR	2SC2878 A,B 068813
⚠ Q308	VG805300	TR	2SA1674 R,S 338943
⚠ Q309	VG805300	TR	2SA1674 R,S 338943
R36	AAX11900	R.CAR.FP	2.2 1/4W 055504
R41	AAX11900	R.CAR.FP	2.2 1/4W 055504
R42	AAX11900	R.CAR.FP	2.2 1/4W 055504
R45	AAX11870	R.CAR.FP	10 1/4W 044452
R46	AAX11950	R.CAR.FP	1 1/4W 084665
R91	AAX11900	R.CAR.FP	2.2 1/4W 055504
R92	AAX11900	R.CAR.FP	2.2 1/4W 055504
R100	AAX11900	R.CAR.FP	2.2 1/4W 055504
R302	AAX11870	R.CAR.FP	10 1/4W 044452
R307	AAX11870	R.CAR.FP	10 1/4W 044452
R312	AAX11870	R.CAR.FP	10 1/4W 044452
R313	AAX11870	R.CAR.FP	10 1/4W 044452
R319	AAX11870	R.CAR.FP	10 1/4W 044452
R350	AAX11870	R.CAR.FP	10 1/4W 044452
R383	AAX11870	R.CAR.FP	10 1/4W 044452
R407	AAX11870	R.CAR.FP	10 1/4W 044452
R408	AAX11870	R.CAR.FP	10 1/4W 044452
R438	AAX11870	R.CAR.FP	10 1/4W 044452
R456	HV754220	R.CAR.FP	22 1/4W 067488
R457	HV754220	R.CAR.FP	22 1/4W 067488
⚠ R462	AAX12280	R.CAR.FP	4.7 1/4W 044143
⚠ R466	HL324100	R.MTL.OXD	10 2W 338947
⚠ R467	HL324100	R.MTL.OXD	10 2W 338947
⚠ R469	AAX12280	R.CAR.FP	4.7 1/4W 044143
SW200	AAX10660	SW.TACT	SKHVBLO38A 072692
SW201	AAX10660	SW.TACT	SKHVBLO38A 072692
SW202	AAX10660	SW.TACT	SKHVBLO38A 072692
SW203	AAX10660	SW.TACT	SKHVBLO38A 072692
SW204	AAX10660	SW.TACT	SKHVBLO38A 072692
SW205	AAX10660	SW.TACT	SKHVBLO38A 072692
* ⚠ T300	AAX28490	TRANS	FL A1A1A0-1 337193
TM300	XX698880	LUG	MET37-0001 075878
TM301	XX698880	LUG	MET37-0001 075878
TM302	XX698880	LUG	MET37-0001 075878
U200	VU591000	L.DTCT	GP1U271X 055310
V200	V6291400	FL.DSPLY	13-BT-180GNK
XL1	Vi552000	RSNR.CRYS	AT-49 12.288MHZ 055312
XL200	VQ791000	RSNR.CE	CST10.OMTW-TF01 055042

* New Parts

AV-S77

AV-S77C P.C.B. AMP & P.C.B. DSP-FL

Schm Ref.	PART NO.	Description		Remarks	
* *	HS101	AAX10890	HEAT.SINK	UOT-16CS25-MP	055523
		AAX10140	CUSHION		055172
		AAX28480	SPACER	LH-5-5	075999

* New Parts

Chip Resistors

Schm Ref.	PART NO.	Description			Remarks
	RD354470	R. CAR. CHP	47	1/16W	067543
	RD354510	R. CAR. CHP	51	1/16W	333377
	RD355100	R. CAR. CHIP	100	1/10W	067493
	RD355330	R. CAR. CHP	330	1/10W	067530
	RD355390	R. CAR. CHP	390	1/10W	067538
	RD355470	R. CAR. CHP	470	1/10W	067544
	RD356100	R. CAR. CHP	1K	1/10W	067495
	RD356180	R. CAR. CHP	1.8K	1/10W	067514
	RD356200	R. CAR. CHP	2K	1/10W	
	RD356220	R. CAR. CHP	2.2K	1/10W	067519
	RD356270	R. CAR. CHP	2.7K	1/10W	067526
	RD356330	R. CAR. CHP	3.3K	1/10W	067531
	RD356360	R. CAR. CHP	3.6K	1/10W	
	RD356390	R. CAR. CHP	3.9K	1/10W	067539
	RD356470	R. CAR. CHP	4.7K	1/10W	067545
	RD356510	R. CAR. CHP	5.1K	1/10W	085050
	RD356560	R. CAR. CHP	5.6K	1/10W	067553
	RD356620	R. CAR. CHP	6.2K	1/10W	
	RD356820	R. CAR. CHP	8.2K	1/10W	067562
	RD357100	R. CAR. CHP	10K	1/10W	067497
	RD357120	R. CAR. CHP	12K	1/10W	067504
	RD357220	R. CAR. CHP	22K	1/10W	067520
	RD357270	R. CAR. CHP	27K	1/10W	067527
	RD357470	R. CAR. CHP	47K	1/10W	067546
	RD357510	R. CAR. CHP	51K	1/10W	
	RD357680	R. CAR. CHP	68K	1/10W	067559
	RD358100	R. CAR. CHP	100K	1/10W	067499
	RD359100	R. CAR. CHP	1M	1/10W	067500

* New Parts

AV-S77

NX-SW77 P.C.B. POWER

Schm Ref.	PART NO.	Description	Remarks
	AAX28240	P.C.B.	POWER AMP 338941
C1	AAX12170	C.CE	100pF 50V 051723
C2	AAX12170	C.CE	100pF 50V 051723
C3	AAX12170	C.CE	100pF 50V 051723
C4	AAX12170	C.CE	100pF 50V 051723
C5	AAX12170	C.CE	100pF 50V 051723
C6	AAX12170	C.CE	100pF 50V 051723
C7	AAX12170	C.CE	100pF 50V 051723
C8	AAX12170	C.CE	100pF 50V 051723
C9	AAX12170	C.CE	100pF 50V 051723
C10	AAX12170	C.CE	100pF 50V 051723
C11	UR848330	C.EL	330uF 25V 066403
C12	XX698870	C.POL	0.01uF 50V 065000
C13	AAX12250	C.EL	22uF 50V 066352
C14	AAX12250	C.EL	22uF 50V 066352
C15	UR867100	C.EL	10uF 50V 066291
C16	UR867100	C.EL	10uF 50V 066291
C17	AAX12170	C.CE	100pF 50V 051723
C18	AAX12170	C.CE	100pF 50V 051723
C19	AAX10380	C.EL	4.7uF 25V 066455
C20	AAX10380	C.EL	4.7uF 25V 066455
C21	AAX12170	C.CE	100pF 50V 051723
C22	AAX12170	C.CE	100pF 50V 051723
C23	XX698300	C.EL	22uF 50V 066377
C24	XX698300	C.EL	22uF 50V 066377
C25	FG212470	C.CE	470pF 50V 332145
C26	FG212470	C.CE	470pF 50V 332145
C27	AAX11280	C.POL	0.047uF 50V 065118
C28	AAX11280	C.POL	0.047uF 50V 065118
C29	AAX11280	C.POL	0.047uF 50V 065118
C30	AAX11280	C.POL	0.047uF 50V 065118
C31	AAX12250	C.EL	22uF 50V 066352
C32	AAX12250	C.EL	22uF 50V 066352
C35	AAX10210	C.EL	100uF 50V 066311
C36	AAX10210	C.EL	100uF 50V 066311
C37	AAX11280	C.POL	0.047uF 50V 065118
C38	AAX11280	C.POL	0.047uF 50V 065118
C39	AAX10170	C.EL	100uF 6.3V 066296
C40	AAX12250	C.EL	22uF 50V 066352
C41	UR867100	C.EL	10uF 50V 066291
C42	UR867100	C.EL	10uF 50V 066291
C43	AAX12170	C.CE	100pF 50V 051723
C44	AAX10380	C.EL	4.7uF 25V 066455
C45	AAX12170	C.CE	100pF 50V 051723
C46	XX698300	C.EL	22uF 50V 066377
C47	AAX12420	C.POL	0.22uF 50V 064921
C48	AAX12420	C.POL	0.22uF 50V 064921
C49	UA655820	C.MYLAR	0.82uF 50V 064944
C50	XX698310	C.EL	47uF 16V 066424
C51	XX698310	C.EL	47uF 16V 066424
C52	AAX12430	C.POL	0.39uF 50V 064932
C53	UA655150	C.MYLAR	0.15uF 50V 065038
C54	AAX10190	C.EL	100uF 6.3V 066302
C55	XX707850	C.POL	0.0022uF 50V 065055
C56	AAX11170	C.POL	0.47uF 50V 064936
C57	AAX09500	C.CE	1000pF 50V 051720
C58	XX698870	C.POL	0.01uF 50V 065000
C59	AAX12260	C.EL	33uF 25V 066391
C60	AAX11180	C.POL	0.1uF 50V 065007
C61	FG245100	C.CE	0.1uF 50V 336369
C62	UR867100	C.EL	10uF 50V 066291
C63	UR867100	C.EL	10uF 50V 066291
C64	UR867100	C.EL	10uF 50V 066291

* New Parts

Schm Ref.	PART NO.	Description	Remarks
C65	AAX12270	C.EL	330uF 16V 066402
C66	AAX12270	C.EL	330uF 16V 066402
C67	AAX12250	C.EL	22uF 50V 066352
C68	AAX12250	C.EL	22uF 50V 066352
C69	AAX10370	C.EL	4700uF 35V 066741
C70	AAX10370	C.EL	4700uF 35V 066741
C71	AAX11280	C.POL	0.047uF 50V 065118
C72	AAX11280	C.POL	0.047uF 50V 065118
C74	VS741700	C.POL	0.01uF 275V 065262
C75	AAX12170	C.CE	100pF 50V 051723
C76	AAX12170	C.CE	100pF 50V 051723
C77	AAX12170	C.CE	100pF 50V 051723
C78	AAX12170	C.CE	100pF 50V 051723
C81	AAX10240	C.EL	1uF 50V 066329
C82	AAX10240	C.EL	1uF 50V 066329
C83	VG892500	C.EL	4700uF 50V 066742
C84	VG892500	C.EL	4700uF 50V 066742
C85	AAX09500	C.CE	1000pF 50V 051720
C86	AAX09500	C.CE	1000pF 50V 051720
C87	UR867100	C.EL	10uF 50V 066291
C88	AAX11180	C.POL	0.1uF 50V 065007
C89	AAX11180	C.POL	0.1uF 50V 065007
C90	AAX11280	C.POL	0.047uF 50V 065118
C91	AAX11280	C.POL	0.047uF 50V 065118
C93	UR867100	C.EL	10uF 50V 066291
C94	AAX12250	C.EL	22uF 50V 066352
C96	XX698300	C.EL	22uF 50V 066377
C97	AAX11280	C.POL	0.047uF 50V 065118
C98	AAX11280	C.POL	0.047uF 50V 065118
C99	AAX09500	C.CE	1000pF 50V 051720
C100	UR867100	C.EL	10uF 50V 066291
C101	AAX10380	C.EL	4.7uF 25V 066455
C102	AAX12170	C.CE	100pF 50V 051723
C103	FG212470	C.CE	470pF 50V 332145
C104	AAX12250	C.EL	22uF 50V 066352
C105	AAX10210	C.EL	100uF 50V 066311
C106	AAX11180	C.POL	0.1uF 50V 065007
C107	AAX11280	C.POL	0.047uF 50V 065118
C108	AAX10170	C.EL	100uF 6.3V 066296
C109	AAX10380	C.EL	4.7uF 25V 066455
C110	AAX12170	C.CE	100pF 50V 051723
C111	FG212470	C.CE	470pF 50V 332145
C112	AAX12250	C.EL	22uF 50V 066352
C113	AAX10210	C.EL	100uF 50V 066311
C114	AAX11180	C.POL	0.1uF 50V 065007
C115	AAX12250	C.EL	22uF 50V 066352
C117	XX698300	C.EL	22uF 50V 066377
C118	AAX11280	C.POL	0.047uF 50V 065118
C119	AAX11280	C.POL	0.047uF 50V 065118
C120	AAX09500	C.CE	1000pF 50V 051720
C121	AAX11280	C.POL	0.047uF 50V 065118
C123	AAX10340	C.EL	47uF 50V 066432
C124	AAX10210	C.EL	100uF 50V 066311
C125	UR867100	C.EL	10uF 50V 066291
C126	AAX10210	C.EL	100uF 50V 066311
C127	UA654680	C.MYLAR	0.068uF 50V 065141
C128	UR867100	C.EL	10uF 50V 066291
C131	AAX12170	C.CE	100pF 50V 051723
C132	AAX12170	C.CE	100pF 50V 051723
C133	AAX12170	C.CE	100pF 50V 051723
C134	AAX12170	C.CE	100pF 50V 051723
C135	XX707850	C.POL	0.0022uF 50V 065055
C136	AAX12170	C.CE	100pF 50V 051723

* New Parts

NX-SW77 P.C.B. POWER

Schm Ref.	PART NO.	Description	Remarks
C137	AAX11180	C. POL	0.1uF 50V 065007
C138	AAX11180	C. POL	0.1uF 50V 065007
C139	AAX11180	C. POL	0.1uF 50V 065007
C140	AAX11180	C. POL	0.1uF 50V 065007
C141	AAX12170	C. CE	100pF 50V 051723
C142	AAX12170	C. CE	100pF 50V 051723
C143	AAX12170	C. CE	100pF 50V 051723
C144	AAX12170	C. CE	100pF 50V 051723
C145	UR867100	C. EL	10uF 50V 066291
* CN1	AAX28390	CN	B 6P-VH 081676
* CN2	AAX28430	CN	B 8P-VH 338865
CN3	AAX12200	CN	4P-VH 081669
CN4	AAX12200	CN	4P-VH 081669
CN5	VL844700	CN	XH B3B 081461
CN6	VC015000	CN	EH 6P 081522
* CN7	AAX28380	CN	B5B-EH 081506
* CN8	AAX28370	CN	B3B-EH 081465
* CN9	AAX28410	CN	5569-8A BLK 085338
CN10	AAX10560	CN	B 3P-VH 081665
CN11	AAX10570	CN	B 5P-VH 081672
⚠ D1	VU264200	DIODE	1SR139-400 069537
⚠ D2	VU264200	DIODE	1SR139-400 069537
⚠ D3	VU264200	DIODE	1SR139-400 069537
⚠ D4	VU264200	DIODE	1SR139-400 069537
D5	AAX12620	DIODE .ZENR	MTZJ5. 6B 069099
D6	iF004600	DIODE	1SS133 069460
D7	iF004600	DIODE	1SS133 069460
D8	iF004600	DIODE	1SS133 069460
D9	iF004600	DIODE	1SS133 069460
D1	iF004600	DIODE	1SS133 069460
D11	iF004600	DIODE	1SS133 069460
D12	AAX12620	DIODE .ZENR	MTZJ5. 6B 069099
D13	iF004600	DIODE	1SS133 069460
⚠ D14	AAX12240	DIODE	RBV602 069599
D15	iF004600	DIODE	1SS133 069460
D16	iF004600	DIODE	1SS133 069460
D17	iF004600	DIODE	1SS133 069460
⚠ D18	AAX12240	DIODE	RBV602 069599
D19	iF004600	DIODE	1SS133 069460
D20	iF004600	DIODE	1SS133 069460
D21	iF004600	DIODE	1SS133 069460
D22	iF004600	DIODE	1SS133 069460
D23	iF008860	DIODE .ZENR	MTZ12B K06012R 014520
⚠ F1	KB000680	FUSE	1.25A 250V 044013
FH101	VP206500	HOLDER .FUS	EYF-52BCT 074277
IC1	XB247A00	IC	uPC4570HA 070111
IC2	XB247A00	IC	uPC4570HA 070111
IC3	XB247A00	IC	uPC4570HA 070111
IC4	XB247A00	IC	uPC4570HA 070111
IC5	XB247A00	IC	uPC4570HA 070111
⚠ IC6	AAX11990	IC	NJM78M12FA 070371
⚠ IC7	AAX12000	IC	NJM79M12FA 070447
IC8	XV466A00	IC	LM1875T 055041
IC9	XV466A00	IC	LM1875T 055041
IC10	XH471A00	IC	M5218AL 070097
IC11	XV466A00	IC	LM1875T 055041
IC12	XV466A00	IC	LM1875T 055041
IC13	AAX13490	IC	STK404-050 AF 058246
* JK1	AAX28170	CN.DIN	8P TC5073-28-4161 056980
* JK2	AAX28180	CN.DIN	13P TCS5094-10-41 056981
* JK3	AAX28600	JACK .PHONE	JY-3556-01-070 339483
L1	AAX12190	COIL .CHOKE	1.5uH 074417
L2	AAX12190	COIL .CHOKE	1.5uH 074417

* New Parts

Schm Ref.	PART NO.	Description	Remarks
L3	AAX12190	COIL .CHOKE	1.5uH 074417
L4	AAX12190	COIL .CHOKE	1.5uH 074417
Q1	iC174020	TR	2SC1740S QRS 055717
Q2	iC287820	TR	2SC2878 A,B 068813
Q3	iC287820	TR	2SC2878 A,B 068813
Q4	iC287820	TR	2SC2878 A,B 068813
Q5	iC174020	TR	2SC1740S QRS 055717
Q6	iC174020	TR	2SC1740S QRS 055717
Q7	iC287820	TR	2SC2878 A,B 068813
Q8	iC287820	TR	2SC2878 A,B 068813
Q9	iC287820	TR	2SC2878 A,B 068813
Q10	iC174020	TR	2SC1740S QRS 055717
Q11	iC287820	TR	2SC2878 A,B 068813
Q12	iC1815M0	TR	2SC1815 Y,GR 073527
Q13	iA101590	TR	2SA1015 O,Y 068587
Q14	iC1815M0	TR	2SC1815 Y,GR 073527
Q15	iA101590	TR	2SA1015 O,Y 068587
Q16	iC287820	TR	2SC2878 A,B 068813
Q17	iC174020	TR	2SC1740S QRS 055717
Q18	AAX09180	FET	2SK304 E 051061
Q19	iC174020	TR	2SC1740S QRS 055717
Q21	iC287820	TR	2SC2878 A,B 068813
Q22	iC287820	TR	2SC2878 A,B 068813
Q23	iC174020	TR	2SC1740S QRS 055717
R1	AAX11870	R. CAR .FP	10 1/4W 044452
R2	AAX11870	R. CAR .FP	10 1/4W 044452
⚠ R7	AAX12280	R. CAR .FP	4.7 1/4W 044143
R10	AAX11870	R. CAR .FP	10 1/4W 044452
R11	AAX11870	R. CAR .FP	10 1/4W 044452
⚠ R36	AAX11870	R. CAR .FP	10 1/4W 044452
⚠ R37	AAX11870	R. CAR .FP	10 1/4W 044452
R42	AAX11870	R. CAR .FP	10 1/4W 044452
R43	AAX11870	R. CAR .FP	10 1/4W 044452
R59	AAX11860	R. CAR .FP	100 1/4W 044153
R60	HV455470	R. CAR .FP	470 1/4W ERD52FJ471
R61	HV755680	R. CAR .FP	680 1/4W
⚠ R69	AAX11870	R. CAR .FP	10 1/4W 044452
R70	AAX11940	R. CAR .FP	1.5K 1/4W 055975
* R77	AAX09780	R. MTL .FLM	20K 1/4W 068187
R86	AAX12370	R. MTL .PLAT	0.1 3W 055475
⚠ R89	AAX12280	R. CAR .FP	4.7 1/4W 044143
⚠ R90	AAX12280	R. CAR .FP	4.7 1/4W 044143
R93	AAX11870	R. CAR .FP	10 1/4W 044452
R94	AAX11870	R. CAR .FP	10 1/4W 044452
R95	AAX11870	R. CAR .FP	10 1/4W 044452
R99	AAX12360	R. MTL .PLAT	0.22 3W 055474
R102	AAX11870	R. CAR .FP	10 1/4W 044452
R108	AAX11870	R. CAR .FP	10 1/4W 044452
R109	AAX11870	R. CAR .FP	10 1/4W 044452
R114	AAX11870	R. CAR .FP	10 1/4W 044452
R115	AAX11870	R. CAR .FP	10 1/4W 044452
⚠ R135	AAX11870	R. CAR .FP	10 1/4W 044452
⚠ R140	AAX11870	R. CAR .FP	10 1/4W 044452
R144	HL315100	R. CAR	100 1W
⚠ R146	AAX12280	R. CAR .FP	4.7 1/4W 044143
R149	AAX11860	R. CAR .FP	100 1/4W 044153
R150	AAX11860	R. CAR .FP	100 1/4W 044153
⚠ RY1	VU161600	RELAY	OSA-SS-224DM3 079766
⚠ RY2	AAX12480	RELAY	DD24D1-0S 055472
⚠ RY3	AAX12490	RELAY	SQT-S-112LMR 055473
⚠ RY4	VU161600	RELAY	OSA-SS-224DM3 079766
ST1	BB071360	TERM	EARTH 055265
ST2	BB071360	TERM	EARTH 055265

* New Parts

■ AV-S77C EXPLODED VIEW

■ AV-S77C MECHANICAL PARTS

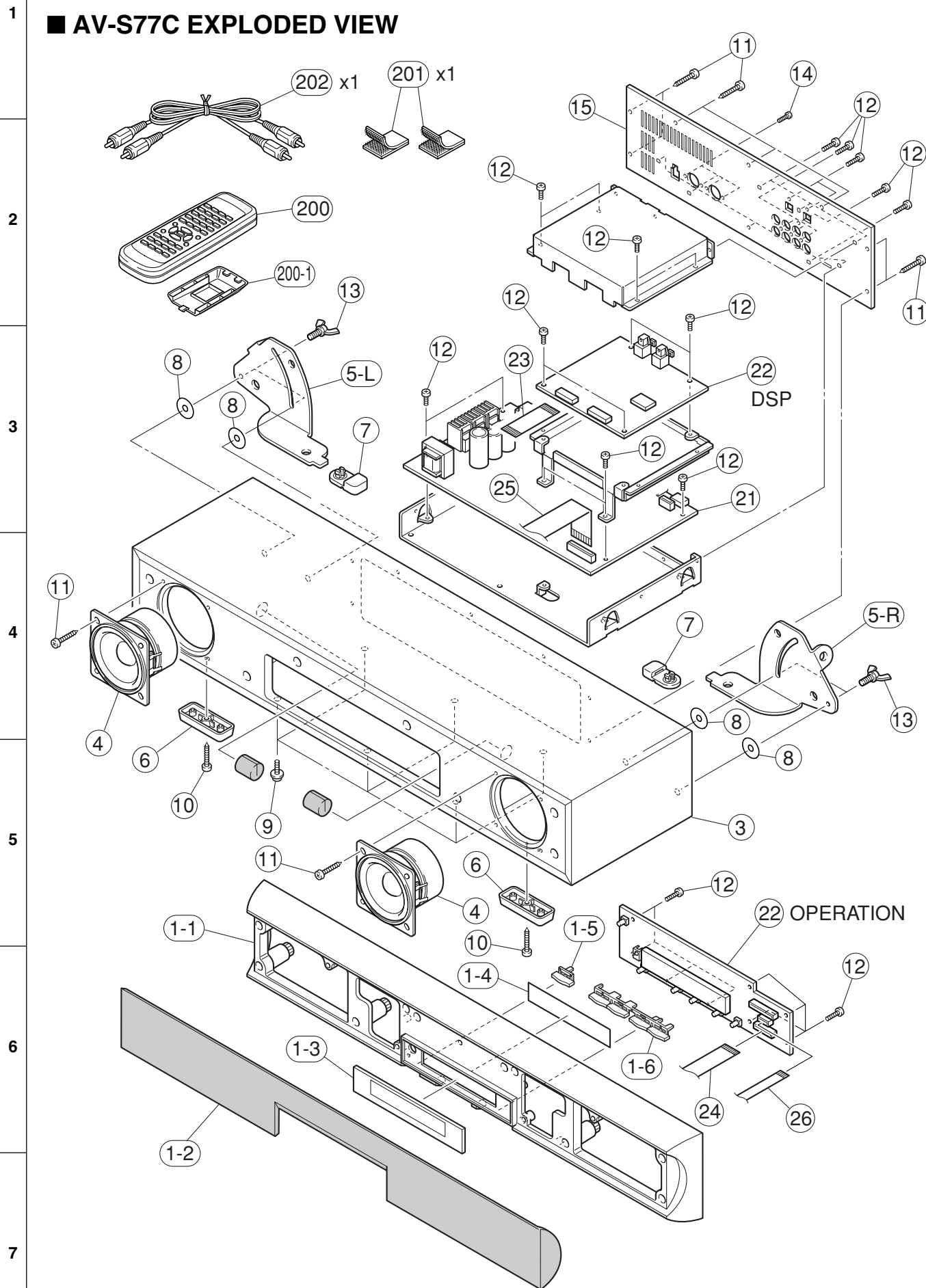

Ref. No.	PART NO.	Description	Remarks	Markets
* 1-1	AAX28590	FRONT PANEL		338422
* 1-2	AAX28340	GRILLE ASS'Y		338426
* 1-3	AAX28270	WINDOW SHEET	WINDOW SHEET	338922
* 1-4	AAX28540	FILTER	BLUE	338417
* 1-5	AAX28620	BUTTON POWER		338418
* 1-6	AAX28610	BUTTON OPERATION		338420
* 3	AAX28290	ENCLOSURE	AV-S77C	350210
4	XY128A00	DRIVER,WOOFER JA0868	8cm	055730
5-R	AAX11080	PLATE,LEG	R	054709
5-L	AAX11090	PLATE,LEG	L	054710
6	AAX11340	FOOT		055583
7	AAX11370	PAD		054711
8	AAX10980	WASHER, FILM		055592
* 9	EK336030	BW HEAD TAPPING SCREW	4x12 MFC2BL	
10	AAX10860	BIND HEAD TAPPING SCREW	3x16 MFZN2BL	021373
11	AAX10870	BIND HEAD TAPPING SCREW	4x12 MFZN2BL	021379
12	EP600190	BIND HEAD B-TITE SCREW	3x8 MFZN2BL	075638
13	AAX11360	WING BOLTS	M4x0.7	057360
* 14	VB096700	BIND HEAD B-TITE SCREW	2.6x8 MFZN2BL	
* 15	AAX28650	REAR PANEL		338921
* 21	AAX28220	P.C.B. ASS'Y	AMP	339148
* 22	AAX28200	P.C.B. ASS'Y	DSP-FL	338951
* 23	AAX28580	FLAT CABLE	15P 60mm AF	338915
* 24	AAX28570	FLAT CABLE	17P 160mm DSP	338914
* 25	AAX28550	FLAT CABLE	23P 130mm MAIN	338912
* 26	AAX28560	FLAT CABLE	9P 250mm WRITER	338913
ACCESSORIES				
* 200	V7736200	REMOTE CONTROL TRANSMITTER		339943
* 200-1	AAX28710	LID		103RRS09311R
201	AAX11350	FASTENER TAPE	2pairs/set	055593
202	AAX10940	PIN CORD	2p RE/WH 3m 1pc	055701
		BATTERY, MANGANESE	SUM-3,AA,R06	

* New Parts

■ NX-SW77 EXPLODED VIEW

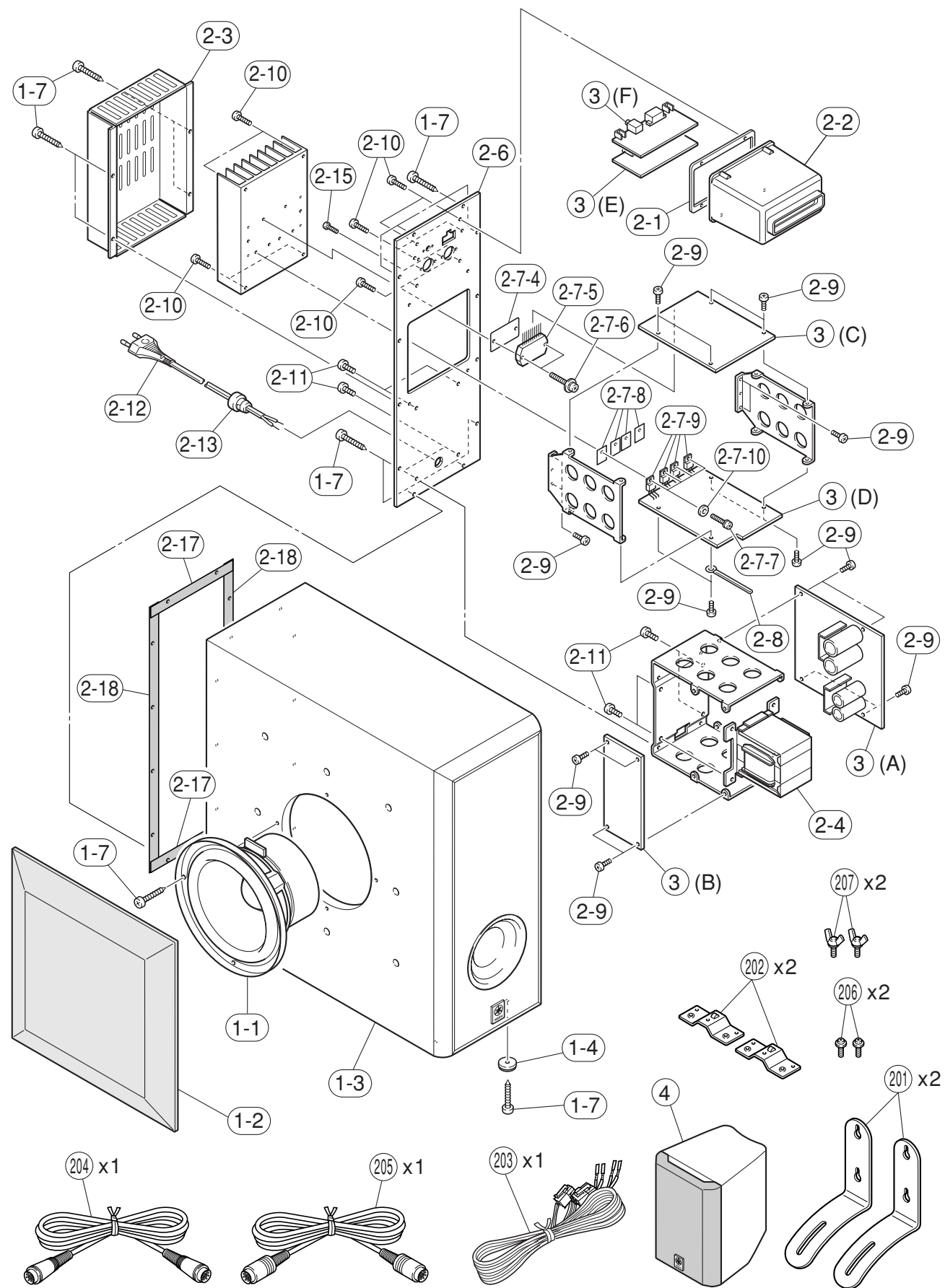

■ NX-SW77 MECHANICAL PARTS

Ref. No.	PART NO.	Description	Remarks	Markets
* 1-1	XY559A00	DRIVER, WOOFER JA1678	16cm 6 25W	058529
* 1-2	AAX28350	GRILLE ASS'Y		338810
* 1-3	AAX28300	ENCLOSURE		350220
1-4	AAX12290	FOOT		055357
1-7	AAX12120	BIND HEAD TAPPING SCREW	4x20 MFZN2BL	021385
* 2-1	AAX28330	CUSHION CASE		338778
* 2-2	AAX28360	CASE		338767
* 2-3	AAX28280	COVER HEATSINK		338766
* 2-4	AAX28700	TRANSFORMER POWER		337192
* 2-6	AAX28660	REAR PANEL		350407
* 2-7-4	AAX28680	INSULATOR MICA		337636
2-7-5	AAX13490	IC	STK404-050 AF	058246
2-7-6	AAX12380	PAN HEAD B-TITE SCREW	3x20 MFZN2BL	055430
2-7-7	V2128100	PW HEAD S-TITE SCREW	3x12-8 MFZN2Y	
2-7-8	AAX10110	INSULATOR	MICA TO-220	044391
2-7-9	XV466A00	IC	LM1875T	055041
2-7-10	AAX11050	CUSHION BUSH	B-24	044543
2-8	AAX12160	BRACKET	CLIP L80 A	078004
2-9	EP600190	BIND HEAD B-TITE SCREW	3x8 MFZN2BL	075638
2-10	AAX10840	BIND HEAD B-TITE SCREW	3x10 MFZN2BL	075640
2-11	EG340190	BIND HEAD B-TITE SCREW	4x8 MFZN2BL	
2-12	VZ163900	POWER CORD		055284
2-12	VZ164000	POWER CORD		076128
2-13	AAX12230	CUSHION STOPPER	SR-4	078519
2-15	VB096700	BIND HEAD B-TITE SCREW	2.6x8 MFZN2BL	
* 2-17	AAX28310	CUSHION	15x133x1	338776
* 2-18	AAX28320	CUSHION	15x373x1	N338777
* 3	AAX28240	P.C.B. ASS'Y	POWER AMP	338941
* 4	AAX28460	SATELLITE SPEAKER UNIT	NX-S77E 1pc	338246
201	AAX12600	WALL BRACKET	1pc	012941
202	AAX12140	BRACKET	1pc	012933
* 203	AAX28470	SPEAKER CORD	4P-8P 1pc	339248
204	AAX11960	DIN CORD	8P 3m 1pc	055905
* 205	AAX28160	DIN CORD	13P 3m 1pc	337256
206	AAX12390	PAN HEAD SCREW-SEMS	M4x8 1pc	017957
207	AAX11360	WING BOLTS	M4x0.7 1pc	057360

* New Parts

Parts List for Carbon Resistors

Value	1/4W Type Part No.	1/6W Type Part No.	Value	1/4W Type Part No.	1/6W Type Part No.
1.0 Ω	HJ35 3100	HF85 3100	10 kΩ	HF45 7100	HF45 7100
1.8 Ω	HJ35 3180	*	11 kΩ	HF45 7110	HF45 7110
2.2 Ω	HJ35 3220	HF85 3220	12 kΩ	HJ35 7120	HF85 7120
3.3 Ω	HJ35 3330	HF85 3330	13 kΩ	HF45 7130	HF45 7130
4.7 Ω	HJ35 3470	HF85 3470	15 kΩ	HF45 7150	HF45 7150
5.6 Ω	HJ35 3560	HF85 3560	18 kΩ	HF45 7180	HF45 7180
10 Ω	HF45 4100	HF45 4100	22 kΩ	HF45 7220	HF45 7220
15 Ω	HJ35 4150	HF85 4150	24 kΩ	HF45 7240	HF45 7240
22 Ω	HF45 4220	HF45 4220	27 kΩ	HJ35 7270	HF85 7270
27 Ω	HJ35 4270	HF85 4270	30 kΩ	HF45 7300	HF45 7300
33 Ω	HF45 4330	HF45 4330	33 kΩ	HF45 7330	HF45 7330
39 Ω	HJ35 4470	HF85 4390	36 kΩ	HF45 7360	HF45 7360
47 Ω	HF45 4470	HF45 4470	39 kΩ	HF45 7390	HF45 7390
56 Ω	HF45 4560	HF45 4560	47 kΩ	HF45 7470	HF45 7470
68 Ω	HF45 4680	HF45 4680	51 kΩ	HF45 7510	HF45 7510
75 Ω	HF45 4750	HF45 4750	56 kΩ	HF45 7560	HF45 7560
82 Ω	HF45 4820	HF45 4820	62 kΩ	HF45 7620	HF45 7620
91 Ω	HF45 4910	HF45 4910	68 kΩ	HF45 7680	HF45 7680
100 Ω	HF45 5100	HF45 5100	82 kΩ	HF45 7820	HF45 7820
110 Ω	HJ35 5110	HF85 5110	91 kΩ	HF45 7910	HF45 7910
120 Ω	HF45 5120	HF45 5120	100 kΩ	HF45 8100	HF45 8100
150 Ω	HF45 5150	HF45 5150	110 kΩ	HF45 8110	HF45 8110
160 Ω	HJ35 5160	*	120 kΩ	HF45 8120	HF45 8120
180 Ω	HF45 5180	HF45 5180	150 kΩ	HF45 8150	HF45 8150
200 Ω	HF45 5200	HF45 5200	180 kΩ	HF45 8180	HF45 8180
220 Ω	HF45 5220	HF45 5220	220 kΩ	HJ35 8220	HF85 8220
270 Ω	HF45 5270	HF45 5270	270 kΩ	HF45 8270	HF45 8270
330 Ω	HF45 5330	HF45 5330	300 kΩ	HF45 8300	HF45 8300
390 Ω	HF45 5390	HF45 5390	330 kΩ	HF45 8330	HF45 8330
430 Ω	HF45 5430	HF45 5430	390 kΩ	HJ35 8390	HF85 8390
470 Ω	HF45 5470	HF45 5470	470 kΩ	HF45 8470	HF45 8470
510 Ω	HF45 5510	HF45 5510	560 kΩ	HJ35 8560	HF85 8560
560 Ω	HF45 5560	HF45 5560	680 kΩ	HJ35 8680	HF85 8680
680 Ω	HF45 5680	HF45 5680	820 kΩ	HJ35 8820	HF85 8820
820 Ω	HF45 5820	HF45 5820	1.0 MΩ	HF45 9100	HF45 9100
910 Ω	HF45 5910	HF45 5910	1.2 MΩ	HJ35 9120	*
1.0 kΩ	HF45 6100	HF45 6100	1.5 MΩ	HJ35 9150	HF85 9150
1.2 kΩ	HF45 6120	HF45 6120	1.8 MΩ	HJ35 9180	HF85 9180
1.5 kΩ	HF45 6150	HF45 6150	2.2 MΩ	HJ35 9220	HF85 9220
1.8 kΩ	HF45 6180	HF45 6180	3.3 MΩ	HJ35 9330	HF85 9330
2.0 kΩ	HJ35 6200	HF85 6200	3.9 MΩ	HJ35 9390	*
2.2 kΩ	HF45 6220	HF45 6220	4.7 MΩ	HJ35 9470	HF85 9470
2.4 kΩ	HJ35 6240	HF85 6240			
2.7 kΩ	HF45 6270	HF45 6270			
3.0 kΩ	HF45 6300	HF45 6300			
3.3 kΩ	HF45 6330	HF45 6330			
3.6 kΩ	HJ35 6360	HF85 6360			
3.9 kΩ	HF45 6390	HF45 6390			
4.7 kΩ	HF45 6470	HF45 6470			
5.1 kΩ	HF45 6510	HF45 6510			
5.6 kΩ	HF45 6560	HF45 6560			
6.8 kΩ	HF45 6680	HF45 6680			
8.2 kΩ	HF45 6820	HF45 6820			
9.1 kΩ	HF45 6910	HF45 6910			

1/4W Type

HJ35 ○○○○
10mm

1/6W Type

HF85 ○○○○
5mm

* : Not available

REMOTE CONTROL TRANSMITTER SCHEMATIC DIAGRAM

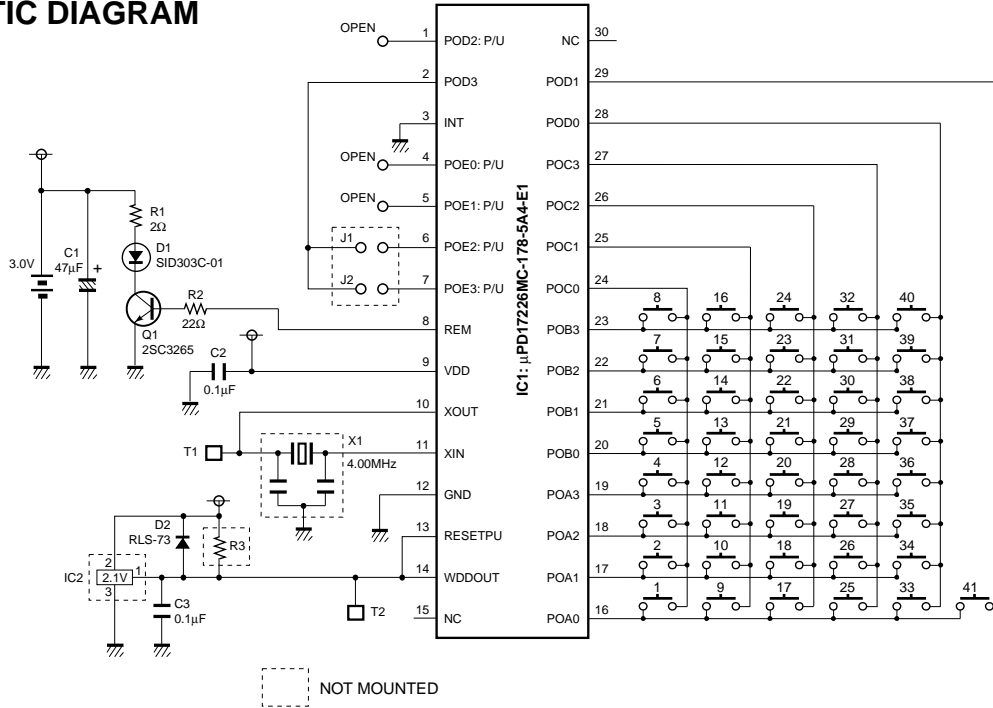

NOT MOUNTED

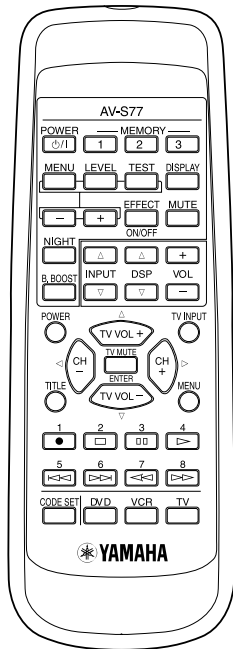

Key No.	Function	CODE			
		DVD mode	TV mode	VCR mode	Setting of Preset
1	POWER	78, 0F	78, 0F	78, 0F	Invalidity
2	MEMORY 1	78, 11	78, 11	78, 11	Invalidity
3	MEMORY 2	78, 12	78, 12	78, 12	Invalidity
4	MEMORY 3	78, 13	78, 13	78, 13	Invalidity
5	MENU	78, 9D	78, 9D	78, 9D	Invalidity
6	LEVEL	78, 48	78, 48	78, 48	Invalidity
7	TEST	78, 5F	78, 5F	78, 5F	Invalidity
8	DISPLAY	78, 4E	78, 4E	78, 4E	Invalidity
9	MENU -	78, 9F	78, 9F	78, 9F	Invalidity
10	MENU +	78, 9E	78, 9E	78, 9E	Invalidity
11	EFFECT ON/OFF	78, 50	78, 50	78, 50	Invalidity
12	MUTE	78, 9C	78, 9C	78, 9C	Invalidity
13	NIGHT	78, 8A	78, 8A	78, 8A	Invalidity
14	INPUT Δ	78, 5E	78, 5E	78, 5E	Invalidity
15	DSP Δ	78, 51	78, 51	78, 51	Invalidity
16	VOL +	78, 1E	78, 1E	78, 1E	Invalidity
17	B BOOST	78, 8B	78, 8B	78, 8B	Invalidity
18	INPUT ▽	78, 40	78, 40	78, 40	Invalidity
19	DSP ▽	78, 52	78, 52	78, 52	Invalidity
20	VOL -	78, 1F	78, 1F	78, 1F	Invalidity
21	Preset	POWER	POWER	POWER	Invalidity
22	Preset	—	TV INPUT	TV INPUT	Invalidity
23	Preset	MENU Δ	TV VOL +	TV VOL +	Invalidity
24	Preset	MENU ◀	CH -	CH -	Invalidity
25	Preset	MENU ENTER	TV MUTE	TV MUTE	Invalidity
26	Preset	MENU ▶	CH +	CH +	Invalidity
27	Preset	MENU ▽	TV VOL -	TV VOL -	Invalidity
28	Preset	TITLE	-	-	Invalidity
29	Preset	MENU	-	-	Invalidity
30	Preset	-	REC	REC	1
31	Preset	STOP	STOP	STOP	2
32	Preset	PAUSE	PAUSE	PAUSE	3
33	Preset	PLAY	PLAY	PLAY	4
34	Preset	SKIP -	-	-	5
35	Preset	SKIP +	-	-	6
36	Preset	SEARCH -	REW	REW	7
37	Preset	SEARCH +	FF	FF	8
38	CODE SET	-	-	-	Keep pressing
39	DVD	-	Change DVD mode	Change DVD mode	mode select
40	VCR	Change VCR mode	Change VCR mode	-	mode select
41	TV	Change TV- mode	-	Change TV- mode	mode select