

STEREO AMPLIFIER AVX-700

SERVICE MANUAL

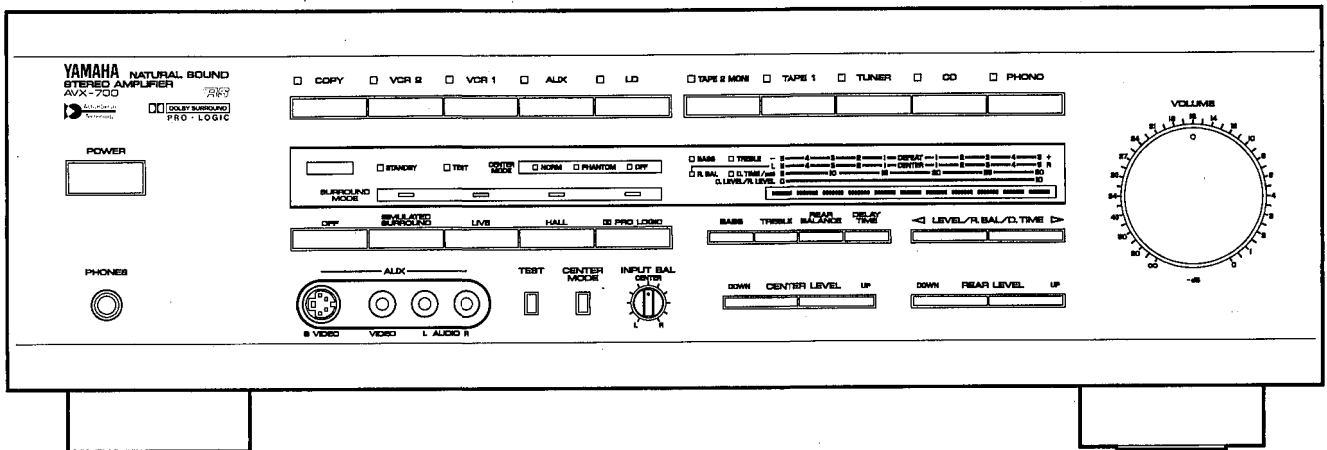

IMPORTANT NOTICE

This manual has been provided for the use of authorized Yamaha Retailers and their service personnel. It has been assumed that basic service procedures inherent to the industry, and more specifically Yamaha Products, are already known and understood by the users, and have therefore not been restated.

WARNING: Failure to follow appropriate service and safety procedures when servicing this product may result in personal injury, destruction of expensive components and failure of the product to perform as specified. For these reasons, we advise all Yamaha product owners that all service required should be performed by an authorized Yamaha Retailer or the appointed service representative.

IMPORTANT: The presentation or sale of this manual to any individual or firm does not constitute authorization, certification or recognition of any applicable technical capabilities, or establish a principle-agent relationship of any form.

The data provided is believed to be accurate and applicable to the unit(s) indicated on the cover. The research, engineering, and service departments of Yamaha are continually striving to improve Yamaha products. Modifications are, therefore, inevitable and specifications are subject to change without notice or obligation to retrofit. Should any discrepancy appear to exist, please contact the distributor's Service Division.

WARNING: Static discharges can destroy expensive components. Discharge any static electricity your body may have accumulated by grounding yourself to the ground buss in the unit (heavy gauge black wires connect to this buss).

IMPORTANT: Turn the unit OFF during disassembly and parts replacement. Recheck all work before you apply power to the unit.

CONTENTS

TO SERVICE PERSONNEL	1	IC BLOCK	7 ~ 10
REMOTE CONTROL TRANSMITTER	1	BLOCK DIAGRAM	11
REAR PANELS	2	INTERCONNECT WIRING DIAGRAM	12
SPECIFICATIONS	3	PRINTED CIRCUIT BOARD	13 ~ 15
INTERNAL VIEW	4	SCHEMATIC DIAGRAM	16 ~ 17
DISASSEMBLY PROCEDURES	4	PARTS LIST	18 ~ 32
ADJUSTMENTS	5 ~ 6		

100299

YAMAHA
YAMAHA CORPORATION
P.O. Box 1, Hamamatsu, Japan

3.2K-171 © Printed in Japan '90.1

AVX-700

■ TO SERVICE PERSONNEL

1. Critical Components Information.

Components having special characteristics are marked Δ and must be replaced with parts having specifications equal to those originally installed.

2. Leakage Current Measurement (For 120V Model Only).

When service has been completed, it is imperative that you verify that all exposed conductive surfaces are properly insulated from supply circuits.

- Meter impedance should be equivalent to 1500 ohm shunted by 0.15 μ F.
- Leakage current must not exceed 0.5mA.
- Be sure to test for leakage with the AC plug in both polarities.

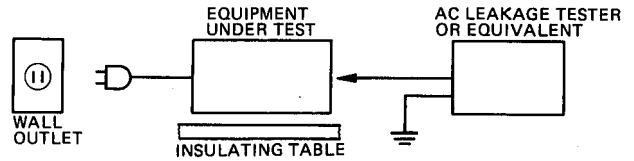

• POLARIZATION

This tuner product is equipped with a polarized alternating-current line plug (a plug having one blade wider than the other). This plug will fit into the power outlet only one way. This is a safety feature. (U, C Model only)

■ REMOTE CONTROL TRANSMITTER

- U.S.A., Canadian, Australian and General models

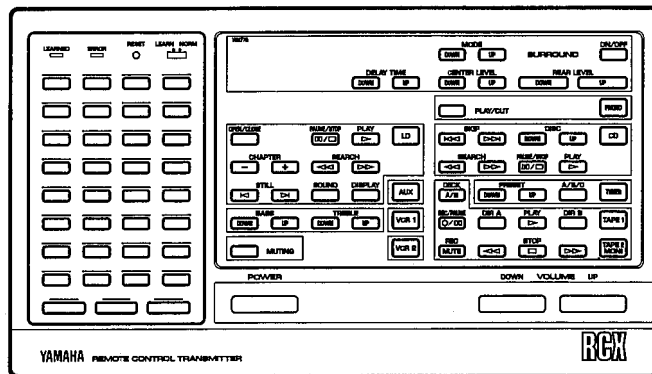

- British and European models

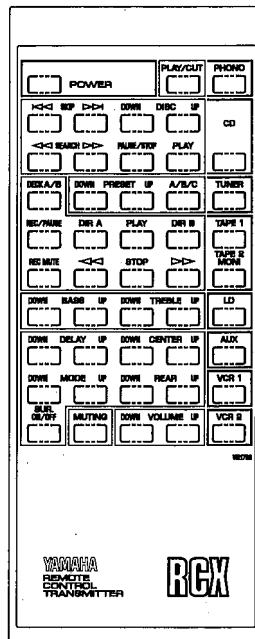

REAR PANELS

- U.S.A. and Canadian models

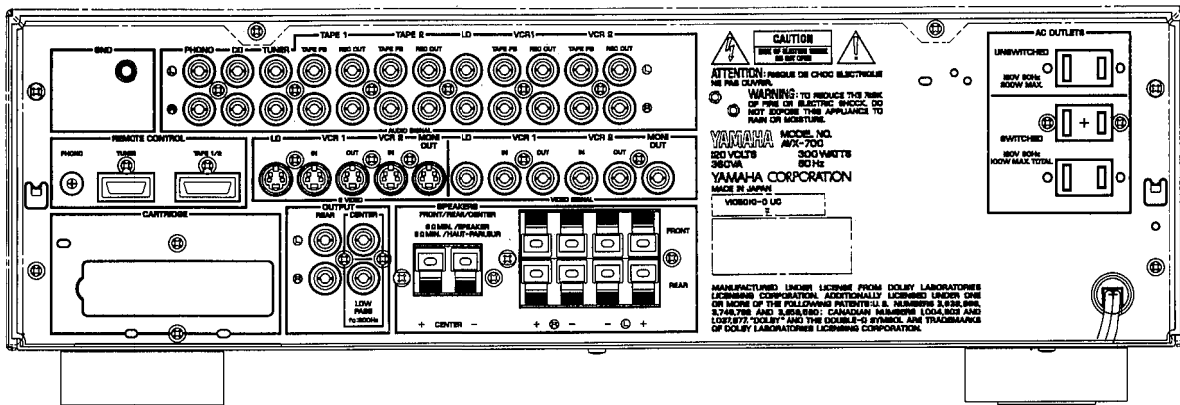

- General model

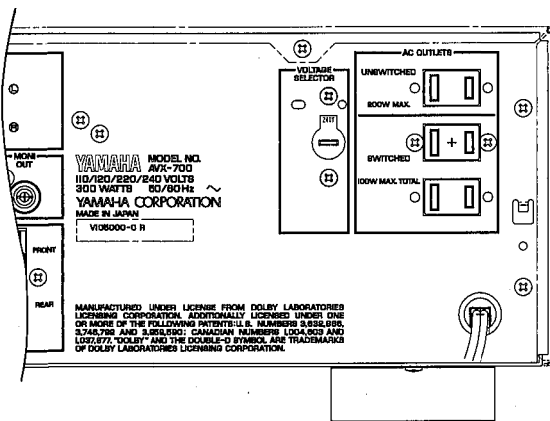

- Australian model

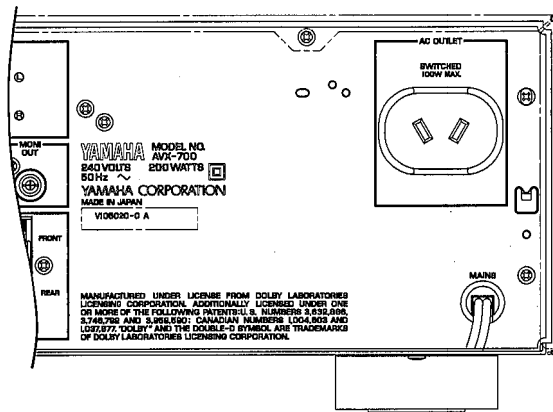

- British model

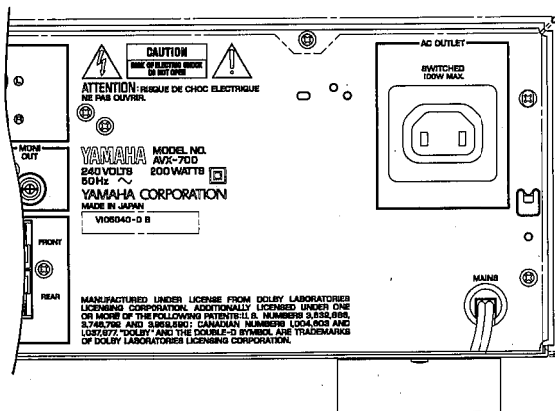

- European model

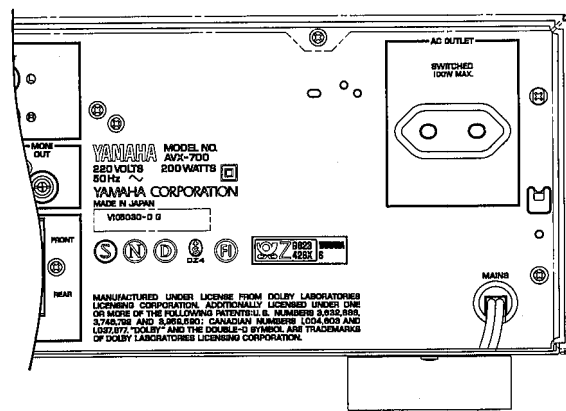

SPECIFICATIONS

AUDIO SECTION

Minimum RMS Output Power Per Channel	
20 Hz - 20 kHz	
0.03% THD, 8 ohms	65W
0.05% THD, 6 ohms	70 W
1 kHz	
1% THD, 8 ohms	14 W
1% THD, 6 ohms	15 W
Dynamic Power Per Channel (by IHF Dynamic Headroom measuring method)	
8 ohms	85 W
6 ohms	105 W
DIN Standard Output Power Per Channel (Europe model only)	
1 kHz, 1% THD, 4 ohms	85 W
Dynamic Headroom	
8 ohms	1.2 dB
6 ohms	1.8 dB
IEC Power (Europe model only)	
1 kHz, 0.03% THD	
8 ohms	70 W
6 ohms	75 W
Damping Factor	
1 kHz, 8 ohms	More than 80
Input Sensitivity/Impedance	
PHONO MM	2.5 mV/47 k-ohms
CD etc.	150 mV/47 k-ohms
Output Level/Impedance	
REC OUT	150 mV/150 ohms
PRE OUT (REAR L/R, CENTER) (Low Pass)	2 V/1 k-ohms 0.7 V/4 k-ohms
Maximum Voltage Output	
20 Hz - 20 kHz, 0.02% THD	4 V
Headphone Jack Rated Output/Impedance	
0.03% THD, 1 kHz, RL=150 ohms	3 V/100 ohms
Frequency Response (20 Hz - 20 kHz)	
CD, etc.	0 ±2 dB
RIAA Equalization Deviation	
PHONO MM	0 ±0.5 dB
Total Harmonic Distortion (20 Hz - 20 kHz)	
PHONO MM, 3 V	Less than 0.01%
CD, etc. to Sp Out, 35 W/8 ohms	Less than 0.02%
CENTER Sp Out, 7 W/8 ohms	Less than 0.5%
REAR L/R Sp Out, 7 W/8 ohms (Vol -30 dB, 1kHz)	Less than 0.5%
Signal to Noise Ratio (IHF-A-Network)	
PHONO MM (5 mV Input Shorted)	More than 86 dB
CD, etc.	More than 98 dB
Residual Noise (IHF-A Network)	
	Less than 150 µV
Channel Separation (Vol -30 dB)	
PHONO MM input shorted, 1 kHz/10 kHz	65 dB/50 dB
CD, etc., input 5.1 k-ohms terminated, 1 kHz/10 kHz	65 dB/50 dB
Tone Control Characteristics	
BASS (boost/cut)	±10 dB (50 Hz)
(turnover frequency)	350 Hz
TREBLE (boost/cut)	±10 dB (20 kHz)
(turnover frequency)	3.5 kHz
Filter Characteristics	
Subsonic (built-in)	15 Hz, 12 dB/oct.
High (surround rear L/R)	7 kHz, 30 dB/oct.
Gain tracking error (0 - -60 dB)	Less than 3 dB
VIDEO SECTION	
Video Signal Type	NTSC (U.S.A. and Canada models) NTSC/PAL (General model) PAL (Australia, Europe and U.K. models)
Video Signal Input/Output	1 Vp-p, 75 ohms
S-Video Signal Input/Output	Y (Luminance): 1 Vp-p, 75 ohms C (Color): 0.286 p-p, 75 ohms
Maximum Input Level	More than 1.5 Vp-p
Video S/N	More than 55 dB

GENERAL

Power Supply	
Europe Model	AC 220V, 50 Hz
General Model	AC 110/120/220/240V, 50/60 Hz
U.K. and Australia Models	AC 240V, 50 Hz
U.S.A. and Canada Models	AC 120 V, 60 Hz
Power Consumption	300W (U.S.A. and General models) 360 VA (Canada model) 200 W (Australia, Europe and U.K. models)
AC Outlets	
Switched x 2	100W max (Total) (U.S.A., Canada and General models)
Switched x 1	100W max. (Europe, U.K. and Australia models)
Unswitched x 1	200W max. (Except for U.K. model)
Dimensions (W x H x D)	435 x 145 x 377 mm (17-1/8" x 5-11/16" x 14-13/16")
Weight	10 kg (22 lbs. 1 oz.)
Accessories	Remote control cable (mini-plug) x 1 Remote control cable (5-pin) x 1 Remote control cable (6-pin) x 1 Video cord x 1 Remote control transmitter x 1 Battery (size "AAA", R03) x 2 (Europe and U.K. models) Battery (size "AA", R6) x 4 (U.S.A., Canada, Australia and General models)

Specification subject to change without notice.

• Dimensions

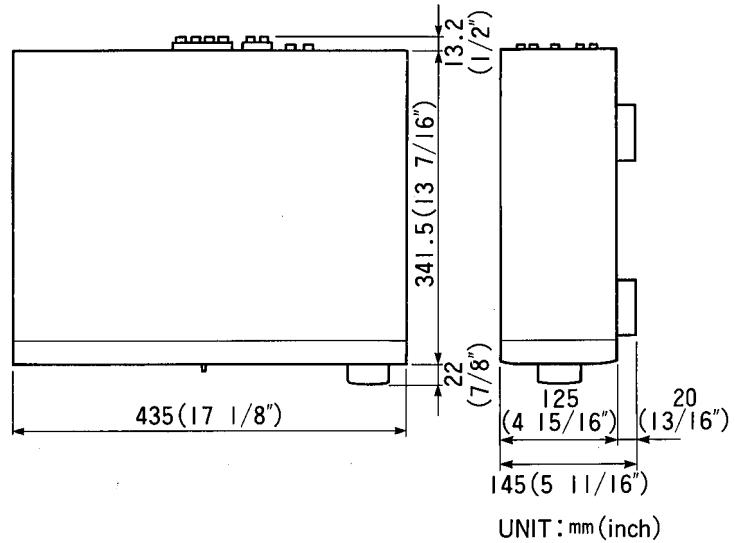

Manufactured under license from Dolby Laboratories Licensing Corporation. Additionally licensed under one or more of the following patents: U.S. numbers 3,632,886, 3,746, 792, and 3,959, 590; Canada numbers 1,004,603 and 1,037,877. "Dolby" and the double-D symbol are trademarks of Dolby Laboratories Licensing Corporation.

INTERNAL VIEW

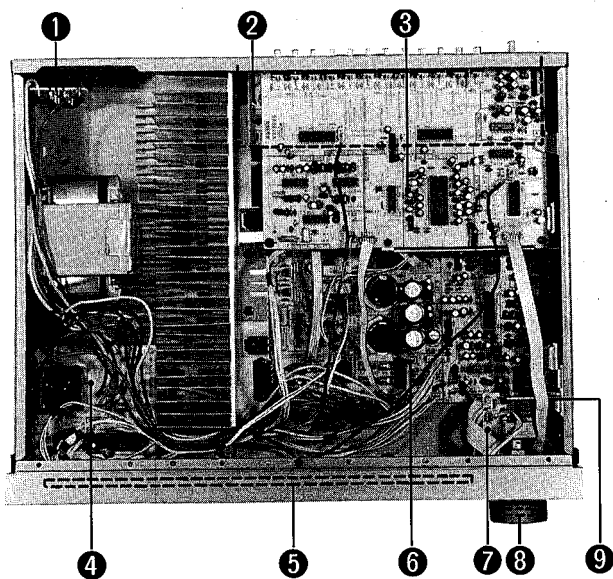

- ① FUNCTION CIRCUIT BOARD (5)
- ② MAIN CIRCUIT BOARD (2)
- ③ FUNCTION CIRCUIT BOARD (1)
- ④ FUNCTION CIRCUIT BOARD (3)
- ⑤ FUNCTION CIRCUIT BOARD (2)
- ⑥ MAIN CIRCUIT BOARD (1)
- ⑦ MAIN CIRCUIT BOARD (3)
- ⑧ FUNCTION CIRCUIT BOARD (4)
- ⑨ MAIN CIRCUIT BOARD (4)

DISASSEMBLY PROCEDURES (Remove parts in the order as numbered.)

1. Removal of top cover

- a. Remove 4 screws (①).
- b. Remove 2 screws (②).
- c. Remove the top cover by lifting it up a little and sliding it rearward.

2. Removal of bottom cover

- a. Remove 4 screws (③).

3. Removal of front panel unit

- a. Remove 3 screws (④).
- b. Remove a plastic rivet (⑤).
- c. Push down the sub-chassis at each point marked A in the figure to release engagement and then remove the front panel by pulling it forward.
- d. Remove a hardware (⑥).
- e. Remove 10 connectors (#2, 4, 7, 8, 9, 10, 12 and 13).
- f. Remove 4 screws (⑦).
- g. Remove the sub-chassis by pulling it forward.

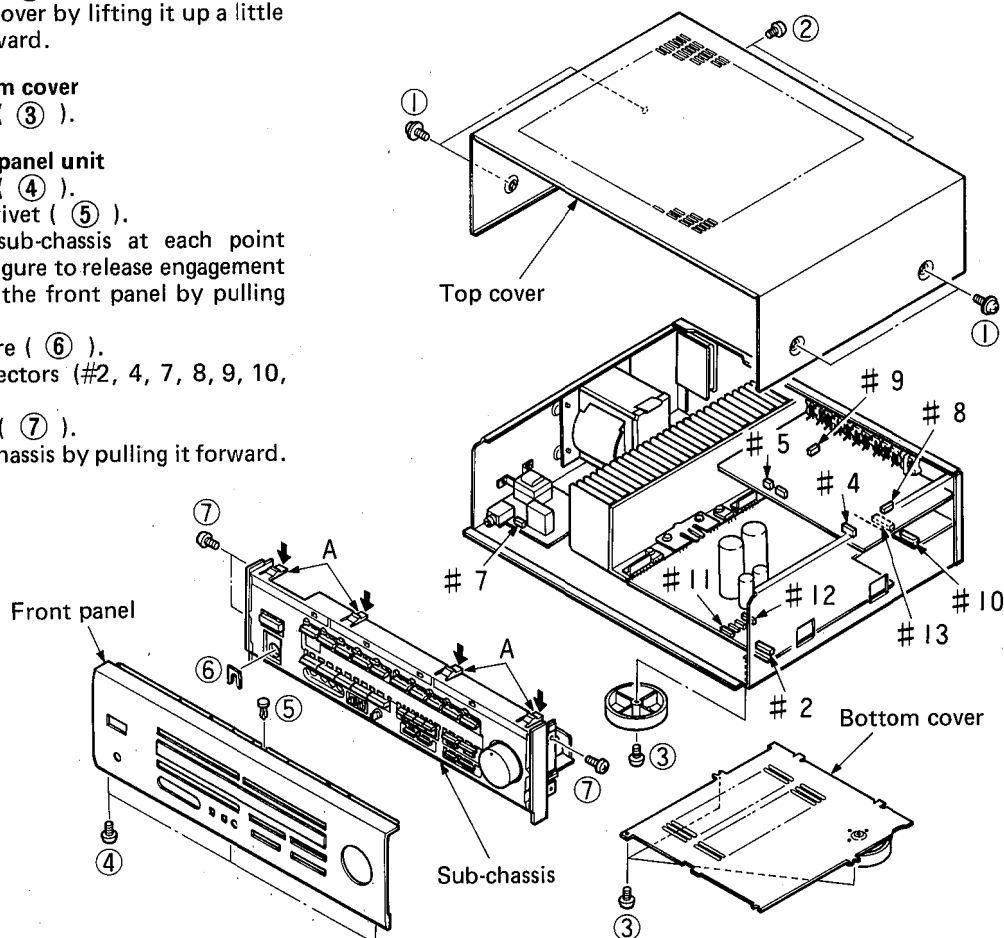

ADJUSTMENTS

Before Adjustments

- Check to make sure that the power supply voltage is AC100V ± 10%.
- To stabilize operation of the amplifier, turn ON the power without applying any load (i.e., nothing connected to the speaker terminal) and wait for 3 minutes.

Adjustment item	Test point	Adjustment point	Rating
Idling current of main amplifier (Front L/R)	Both ends of R421 or R423 (L ch)	VR203	DC1mV ~ 2mV
	Both ends of R422 or R424 (R ch)	VR202	DC1mV ~ 2mV

Test Points

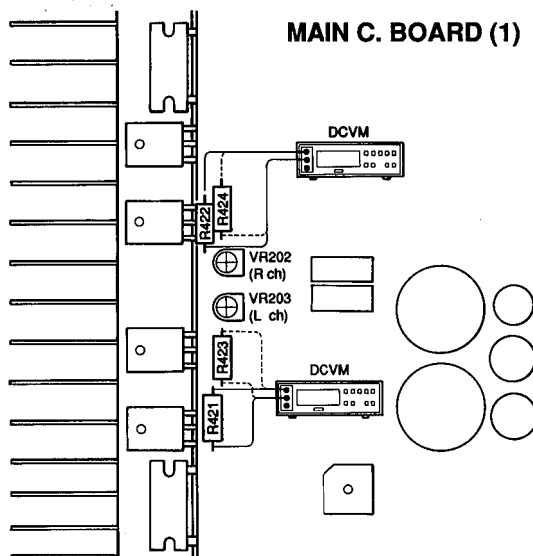

Checking by Using Diagnosis Program

This unit has a diagnosis program to facilitate checking and measuring work. Use this program for checking according to the following procedure.

1. Starting Diagnosis Program

While holding down 3 keys (OFF, SIMULATED SURROUND and LIVE) from the left of the surround selector simultaneously, turn ON the POWER switch, and the indicator of the VOLUME control lights and the diagnosis program is started.

2. Cancelling Diagnosis Program

Turn OFF the power by pressing the POWER switch, and the diagnosis program is cancelled and all the back-up data items are restored to their initial setting as follows.

[Initial setting]

Input Audio	CD
Video	LD
TAPE 2 MONITOR	OFF
COPY	OFF
SURROUND MODE	PROLOGIC
CENTER MODE	NORMAL
DELAY TIME	20mS
BASS	DEFEAT
TREBLE	DEFEAT
REAR BALANCE	CENTER
REAR LEVEL	-12dB
CENTER LEVEL	-12dB

3. Contents of Diagnosis Program

Unless otherwise specified, the data in the diagnosis program are set as follows.

Input Audio	CD
Video	LD
TAPE 2 MONITOR	OFF
COPY	OFF
SURROUND MODE	Single DELAY only (Comb filter, front mix, pro logic and dolby B are OFF.)
DELAY TIME	30mS
BASS	DEFEAT
TREBLE	DEFEAT
REAR BALANCE	CENTER
REAR LEVEL	-∞dB
CENTER LEVEL	-∞dB

① LED ON/OFF Check 1 (PHONO SW1)

Press the PHONO key and check that the LEDs light in the following order.

All ON → PHONO(D13) → CD(D14) → TUNER(D15) → TAPE 1(D16) → TAPE 2(D17) → LD(D18) → AUX(D19) → VCR 1(D20) → VCR 2(D21) → COPY (D22) → STANDBY(D42) → SIMULATED → SUR (D46) → TEST(D41) → LIVE(D45) → NORMAL (D40) → HALL(D44) → PHANTOM(D39) → PRO LOGIC(D43) → OFF(D38) → REAR BALANCE (D37) → BASS(D36) → DELAY(D35) → TREBLE (D34) → 1st level indicator L1(D33) → L2(D32) → L3(D31) → L4(D30) → L5(D29) → L6(D28) → L7 (D27) → L8(D26) → L9(D25) → L10(D24) → 11th level indicator L11(D23) → All ON → All OFF

Pressing the PHONO key while the above check is going on causes the check operation to stop as long as the key is pressed.

To cancel the check operation, press the CD key. If LED ON/OFF check 1 is performed immediately after LED ON/OFF check 2 or LED ON/OFF check 4 described below, the check speed will be increased.

②-1 LED ON/OFF check 2 (CD SW2)

Press the CD key and check that the LEDs light in the following order repeatedly.
PHONO, CD, TUNER, TAPE 1, TAPE 2, LD, AUX, VCR 1, VCR 2, COPY(D13~D22) → All level indicators L1 through L11(D23~D33) → BASS, TREBLE, REAR, BALANCE, DELAY, NORMAL, PHANTOM, OFF(D34~D40) → TEST, STANDBY, SIMULATED SUR, LIVE, HALL, PRO LOGIC(D42~D46) →

②-2 Key Check (CD SW2)

Press the below listed keys while the above ②-1 check is going on, and the LED corresponding to each key should flash.

In any mode other than ②-1, the VOLUME control indicator should flash.

LEVEL UP(SW11)	L11(D23)
LEVEL DOWN(SW12)	L10(D24)
DELAY(SW13)	DELAY(D35)
REAR BALANCE(SW14)	REAR BALANCE(D37)
TREBLE(SW15)	TREBLE(D34)
BASS(SW16)	BASS(D36)
PRO LOGIC(SW17)	PRO LOGIC(D43)
HALL(SW18)	HALL(D44)
LIVE(SW19)	LIVE(D45)
SIMULATED SUR(SW20)	SIMULATED SUR(D46)
OFF(SW21)	STANDBY(D42)
CENTER MODE(SW26)	NORMAL(D40)
TEST(SW27)	TEST(D41)

③ Setting for TREBLE characteristic measurement (TUNER SW3)

The TREBLE characteristic should change in the order of DEFEAT, MAX and MIN every time the TUNER key is pressed.

④ Setting for BASS characteristic measurement (TAPE 1 SW4)

The BASS characteristic should change in the order of DEFEAT, MAX and MIN every time the TAPE 1 key is pressed.

⑤ Setting for MAXIMUM OUTPUT measurement (TAPE 2 SW5)

Each level is set as follows when the TAPE 2 key is pressed.

REAR LEVEL	-6dB
CENTER LEVEL	-6dB

⑥ Setting for measurement of S/N, frequency, etc. (LD SW6)

Each level is set as follows when the LD key is pressed.

REAR LEVEL	0dB
CENTER LEVEL	0dB

⑦ Setting for REAR and CENTER characteristics measurement (AUX SW7)

Each item is set as follows when the AUX key is pressed.

Internal main path	Open
REAR LEVEL	0dB
CENTER LEVEL	0dB

(The front output becomes OFF.)

⑧ SURROUND PATH verification (VCR1 SW8)

Each item is set as follows when the VCR1 key is pressed.

Internal main path	Open
Comb filter	ON
Front mix	ON
REAR LEVEL	0dB
CENTER LEVEL	0dB

(Rear signal is output at the front output.)

⑨ Setting for PRO LOGIC characteristic measurement (VCR2 SW9)

Each item is set as follows when the VCR2 key is pressed.

PRO LOGIC	ON
REAR LEVEL	-12dB
CENTER LEVEL	-12dB

When pressing the VCR2 key is repeated further, the center mode changes in the order of NORMAL, PHANTOM and OFF every time it is pressed.

⑩ Setting for PRO LOGIC test mode measurement (COPY SW10)

Each item is set as follows when the COPY key is pressed.

PRO LOGIC	ON (test mode)
REAR LEVEL	-12dB
CENTER LEVEL	-12dB

When pressing the COPY key is repeated further, the test tone changes in the order of LEFT, CENTER, RIGHT and REAR every time it is pressed.

⑪ LED ON/OFF check 3 (REAR UP SW22, REAR DOWN SW23, CENTER UP SW24)

Press each key repeatedly and check that each of LEDs lights as described below every time it is pressed.

REAR UP keyPHONO, CD, TUNER, TAPE 1, TAPE 2, LD, AUX, VCR 1, VCR 2, COPY(D13~D22)
REAR DOWN key . . .All level indicators L1 through L11(D23~D33)
CENTER UP key . . .BASS, TREBLE, REAR, BALANCE, DELAY, NORMAL, PHANTOM, OFF, TEST, STANDBY, SIMULATED SUR, LIVE, HALL, PRO LOGIC(D34~D46)

⑫ LED ON/OFF check 4 (CENTER DOWN SW25)

Press the CENTER DOWN key and check that each LED of PHONO, TUNER, TAPE 2, AUX, VCR 2, L2, L4, L6, L8, L10, REAR BALANCE, DELAY, SIMULATED SUR, LIVE, HALL and PRO LOGIC and each LED of CD, TAPE 1, LD, VCR 1, COPY, L1, L3, L5, L7, L9, L11, BASS, TREBLE, NORMAL, PHANTOM, OFF, TEST and STANDBY light alternately and repeatedly.

IC BLOCK

IC1,4,211,212,214,217~220,
222,223 : μ PC4570HA
IC221 : NJM4556S
(Dual Ope-Amp)

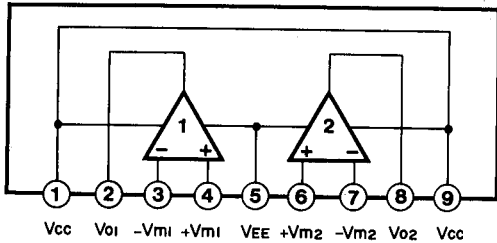

IC2 : LC7822N
(Function Selector)

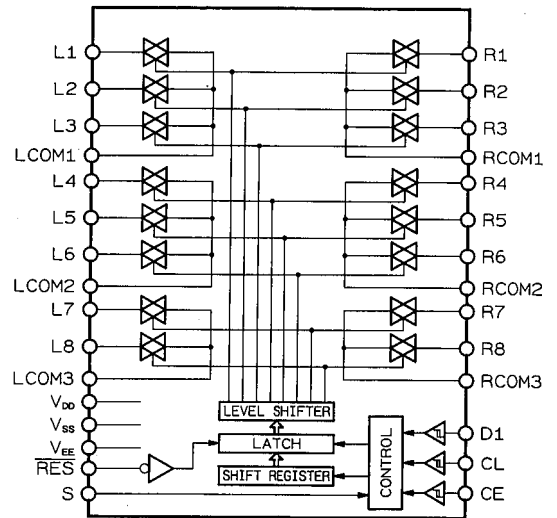
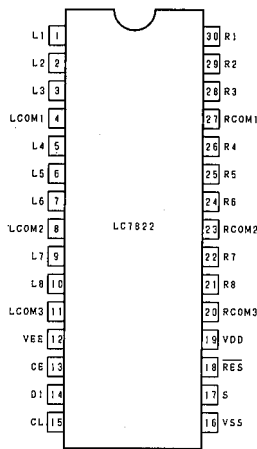

IC3,7 : LC7821N
(Function Selector)

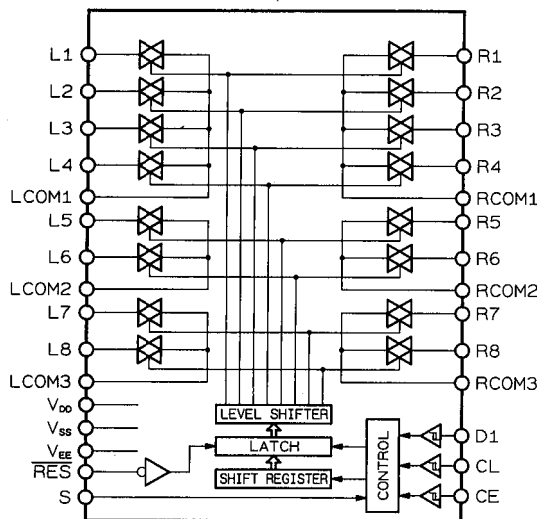
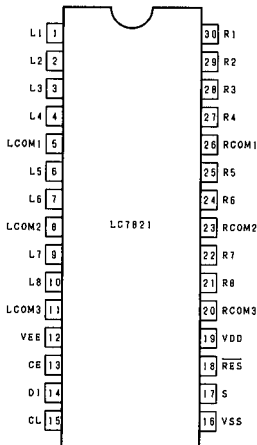

IC5 : TC4069 μ BP
(Hex Inverters)

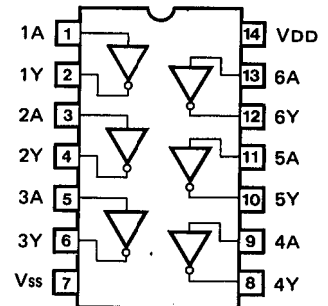

IC6,10 : μ PC4574C
(Ope-Amp)

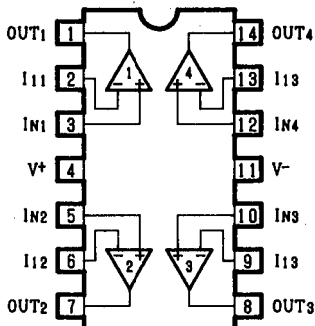

IC8 : LA2770
(Dolby Pro-logic)

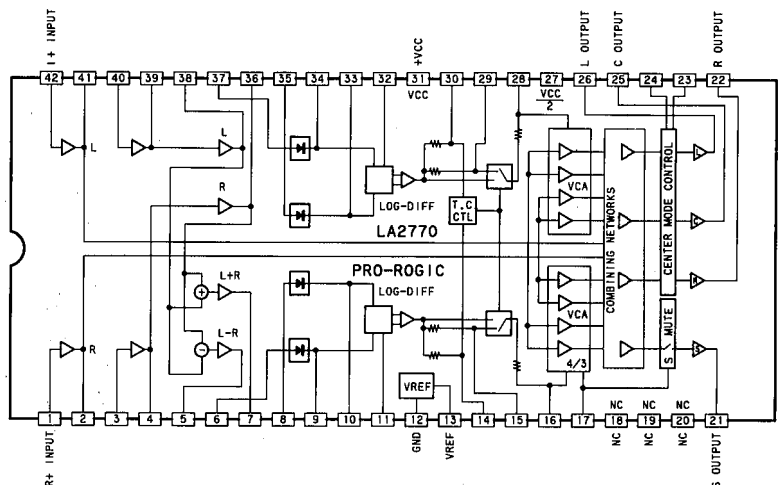

IC9 : μ PD4052BC
IC201,202 : TC4052BP or μ PD4052BC
(Differential 4-ch Multiplexer)

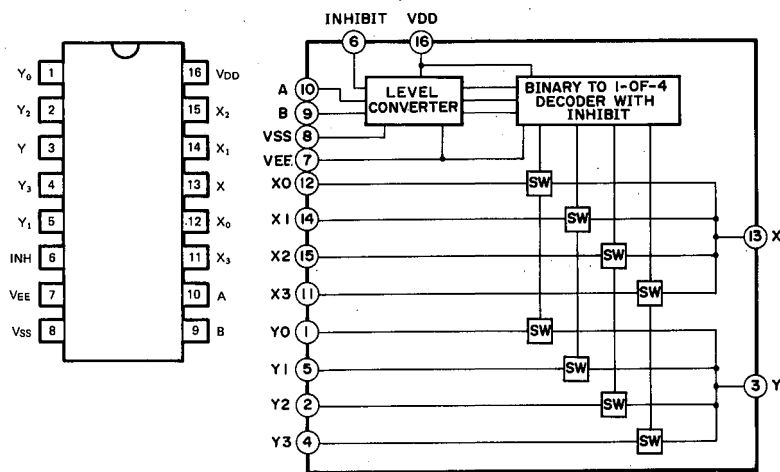

IC11 : μ PC1571C
(Compressor)

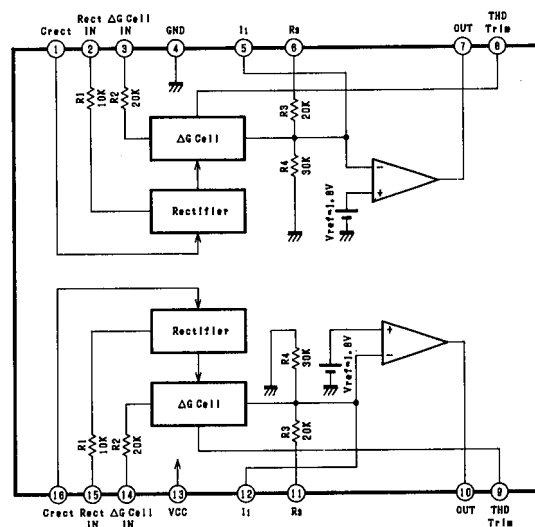

IC12 : YM3428
(Digital Delay)

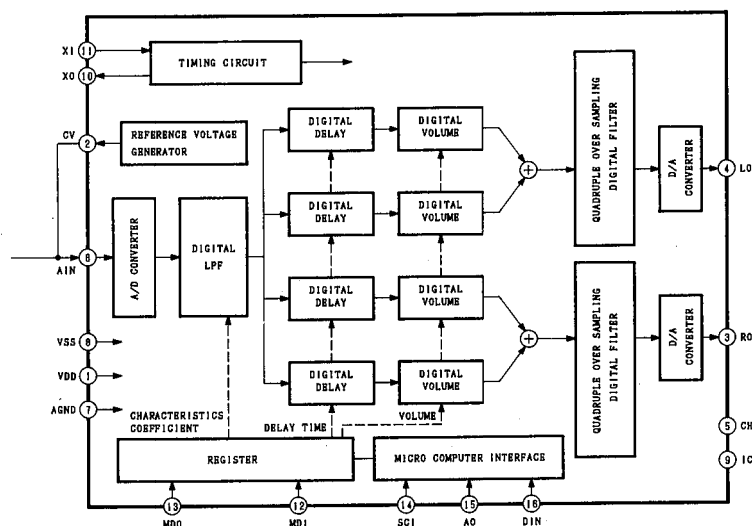

IC14 : M5416P
(Transistor Array)

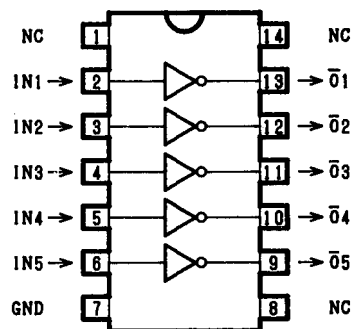

IC15 : BA6418N
(Motor Driver)

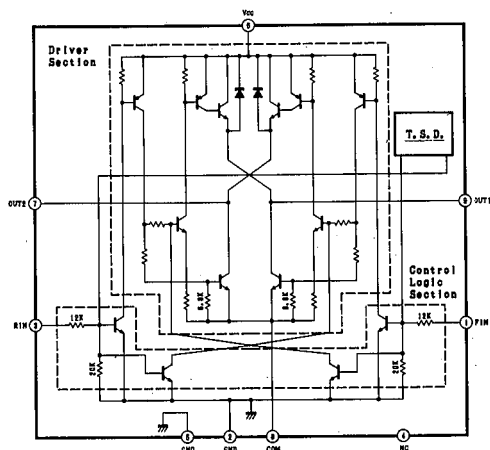

IC13 : M50747-B86
(Micro Computer)

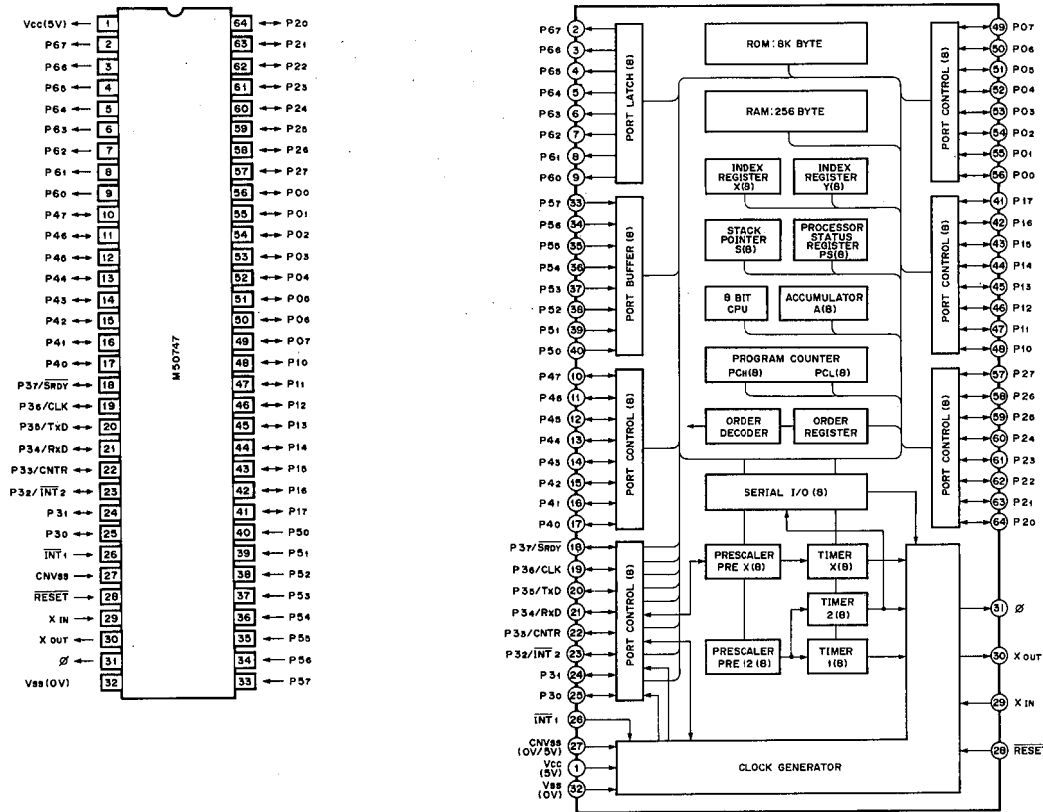

IC13 : M50747 IC DATA

PIN NO.	PIN NAME	I/O	FUNCTION	PIN NO.	PIN NAME	I/O	FUNCTION
1	Vcc	0	+5V	33		I	
2		0		34		I	
3	Sg	0	LED segment g	35	K5	I	Key input matrix 5
4	Sf	0	LED segment f	36	K4	I	Key input matrix 4
5	Se	0	LED segment e	37	K3	I	Key input matrix 3
6	Sd	0	LED segment d	38	K2	I	Key input matrix 2
7	Sc	0	LED segment c	39	K1	I	Key input matrix 1
8	Sb	0	LED segment b	40	K0	I	Key input matrix 0
9	Sa	0	LED segment a	41		0	
10		0		42	PHN	0	RS phono play/cut
11		0		43	TU0	0	RS tuner 0
12		0		44	TU1	0	RS tuner 1
13	PSW	I	Power switch	45	TP0	0	RS tape 0
14	HPIN	I	Headphones in (active L)	46	TP1	0	RS tape 1
15	PDET	I	Power down detect	47	TP2	0	RS tape 2
16	PRY	0	Power relay control	48	TP3	0	RS tape 3
17	SS	0	Surround L-R/L+R	49	V1	0	Video select 1
18		0		50	V0	0	Video select 0
19	SCI	I	Serial clock in	51	IND	0	Volume indicator
20	SDT	0	Serial data out	52	SRY	0	Speaker relay
21	SCK	0	Serial clock out	53	ASO	0	AST control
22	CET	0	LC7537 chip enable	54	ASI	I	AST on (active L)
23	CES	0	LC78xx chip enable	55	PRT	I	Protection (active L)
24	CED	0	YM3428 chip enable	56	MUT	0	Muting
25	REMIN	I	Remote control signal input	57	STB	0	Standby indicator
26	REMIN	I	Remote control, signal input	58	VDN	0	Volume down
27	CNVss	-	GND	59	VUP	0	Volume up
28	RESET	I	Reset (active L)	60	D4	0	Digit out 4
29	Xin	I	Oscillator in	61	D3	0	Digit out 3
30	Xout	0	Oscillator out	62	D2	0	Digit out 2
31	φ	0		63	D1	0	Digit out 1
32	Vss	-	GND	64	D0	0	Digit out 0

**IC213 : LA2730
(Dolby Encoder/Decoder)**

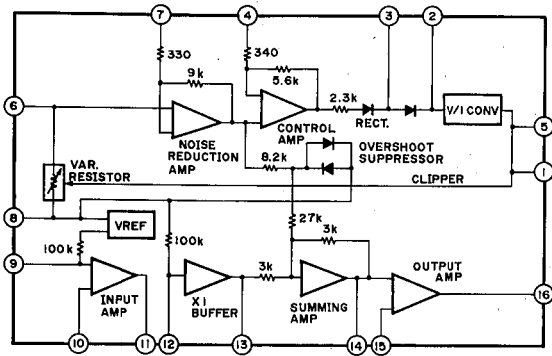

**IC215 : LC7823N
(Analog Function Switch)**

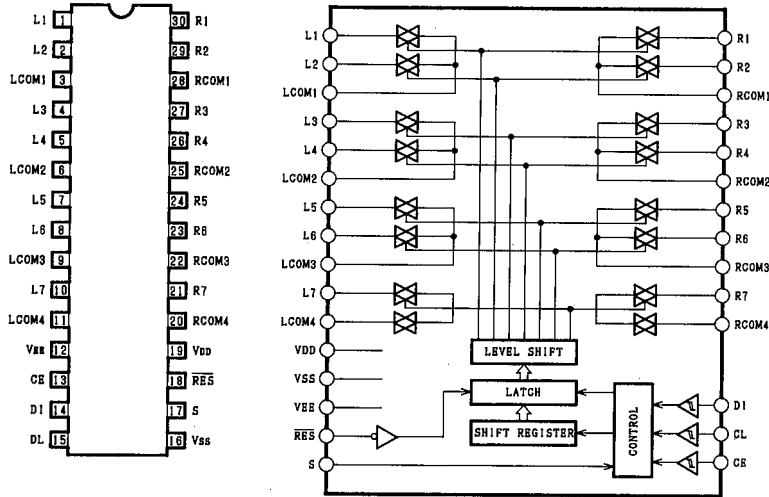

**IC224~226 : μ PC1188H
(Power IC)**

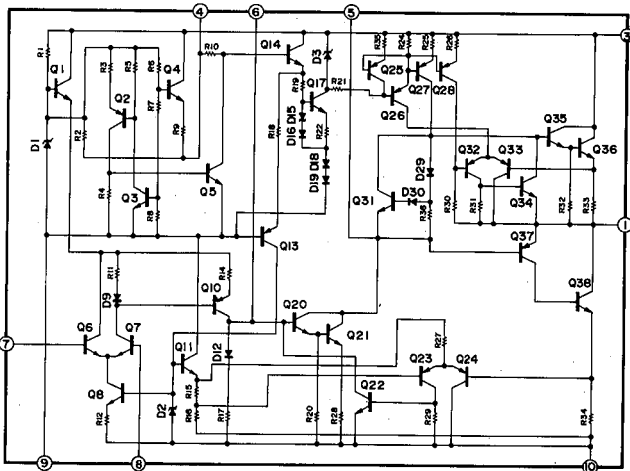

**IC216 : LC7537N
(Electrolytic Volume)**

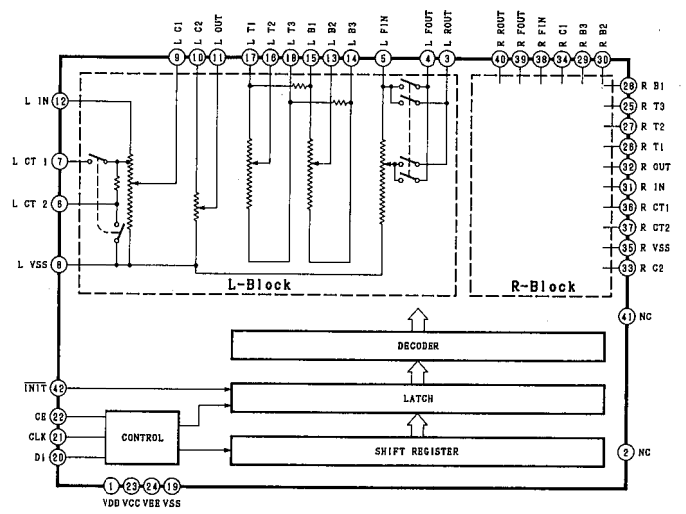

**IC229 : μ PD4053BC
(Triple 2-ch Multiplexer/
Demultiplexer)**

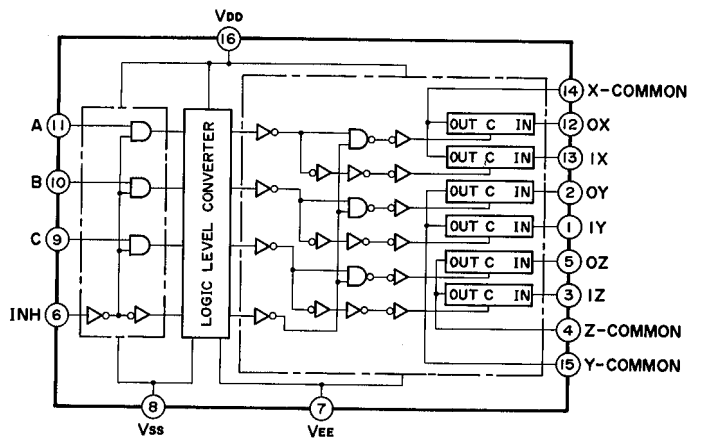

■ BLOCK DIAGRAM

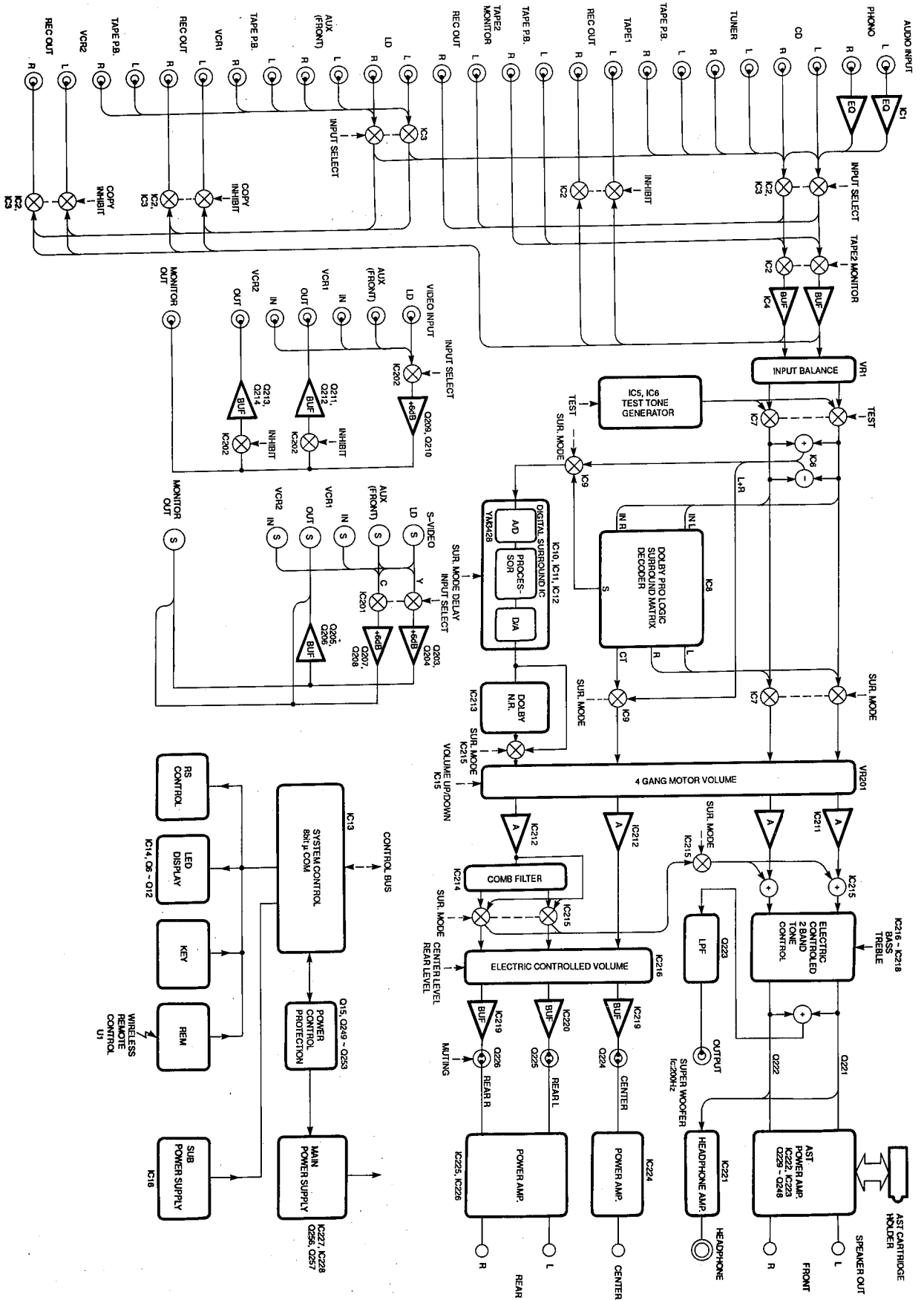

■ INTERCONNECT WIRING DIAGRAM

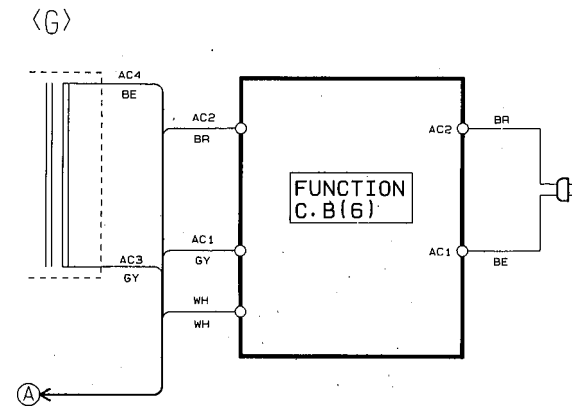
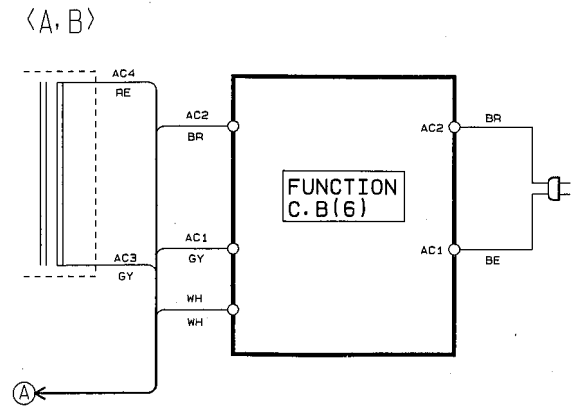
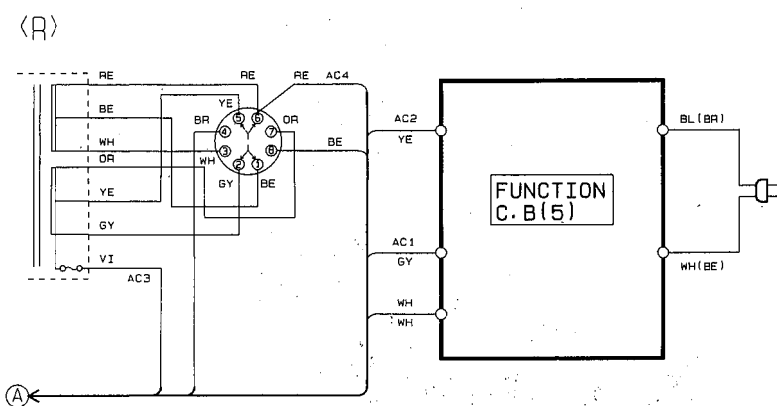
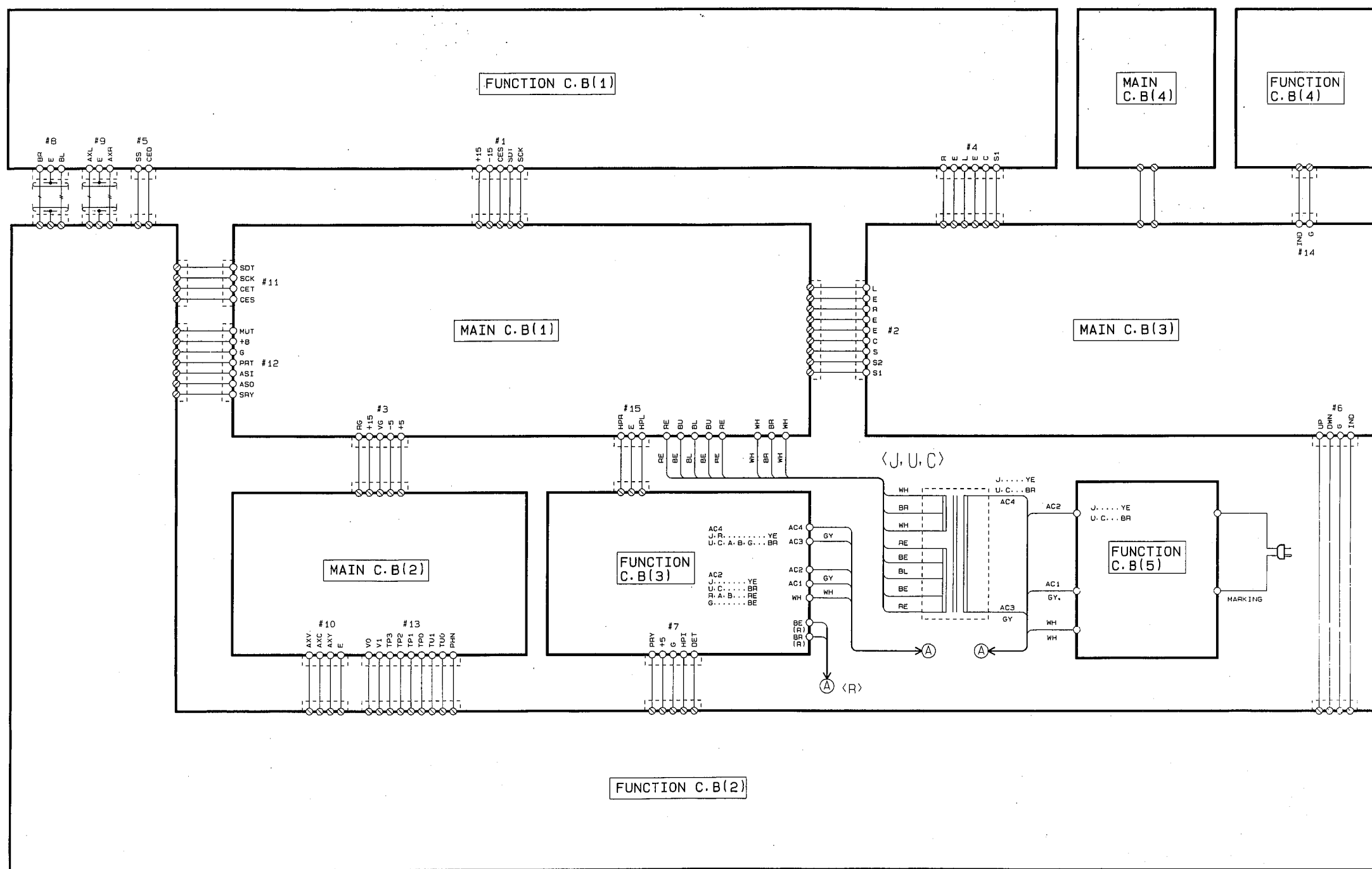

AVX-700

PRINTED CIRCUIT BOARD (Pattern side)

Notes) 文字面 : Component side

MAIN Circuit Board (1)

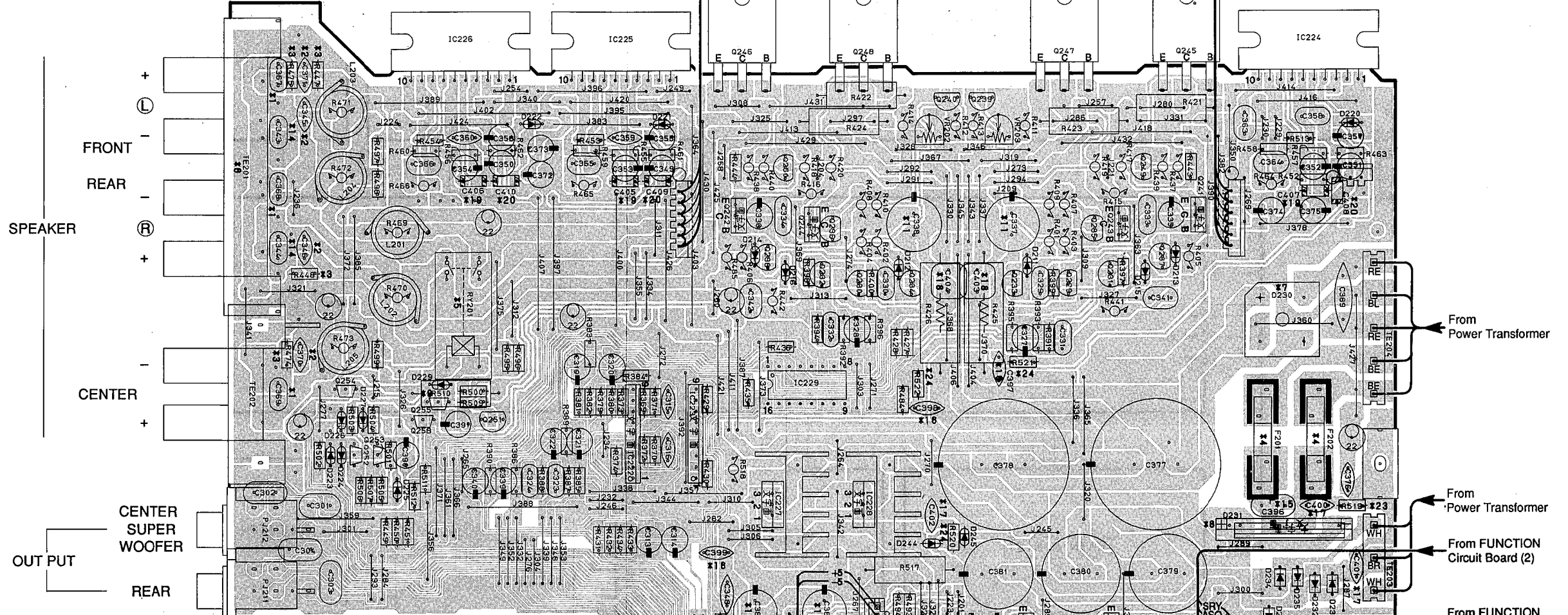

MAIN Circuit Board (4)

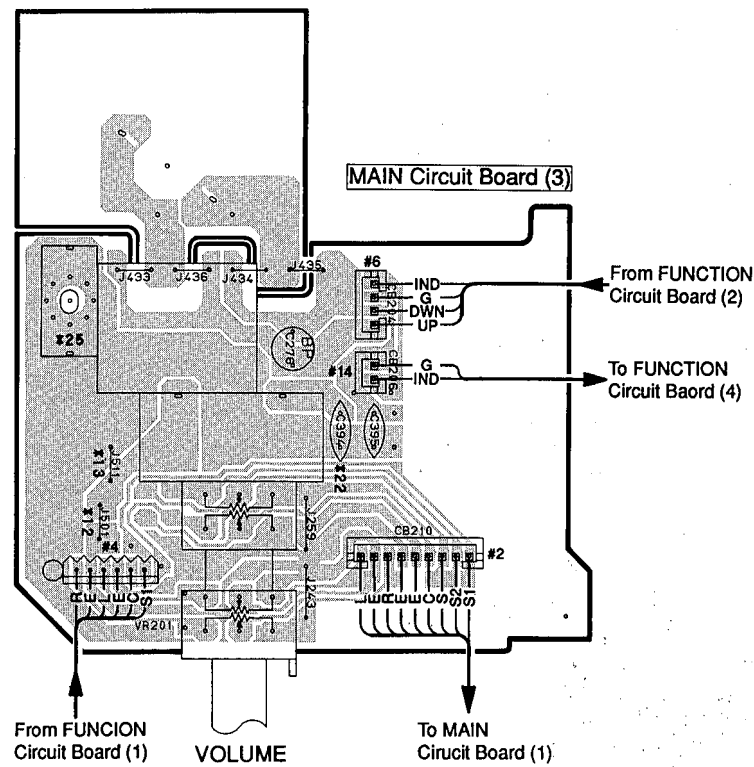

MAIN Circuit Board (3)

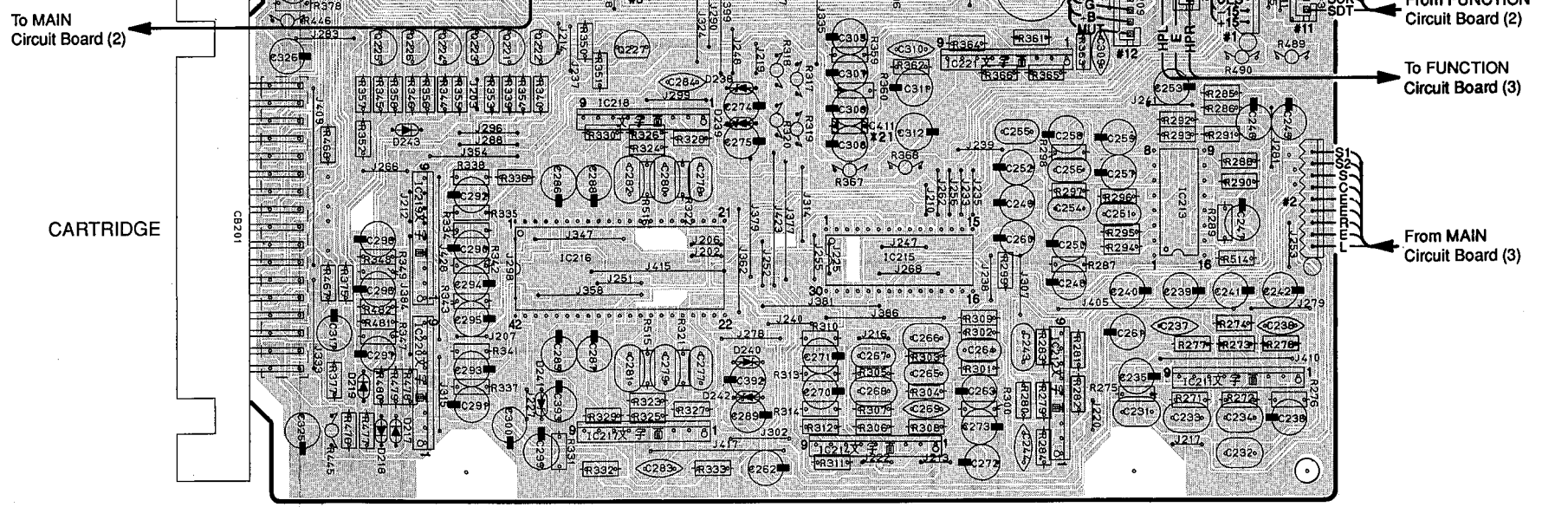

1

2

3

4

5

6

7

PRINTED CIRCUIT BOARD (Pattern side)

Notes) 文字面 : Component side

Note : * Marked for Main C. Boards

MAIN Circuit Board (2)

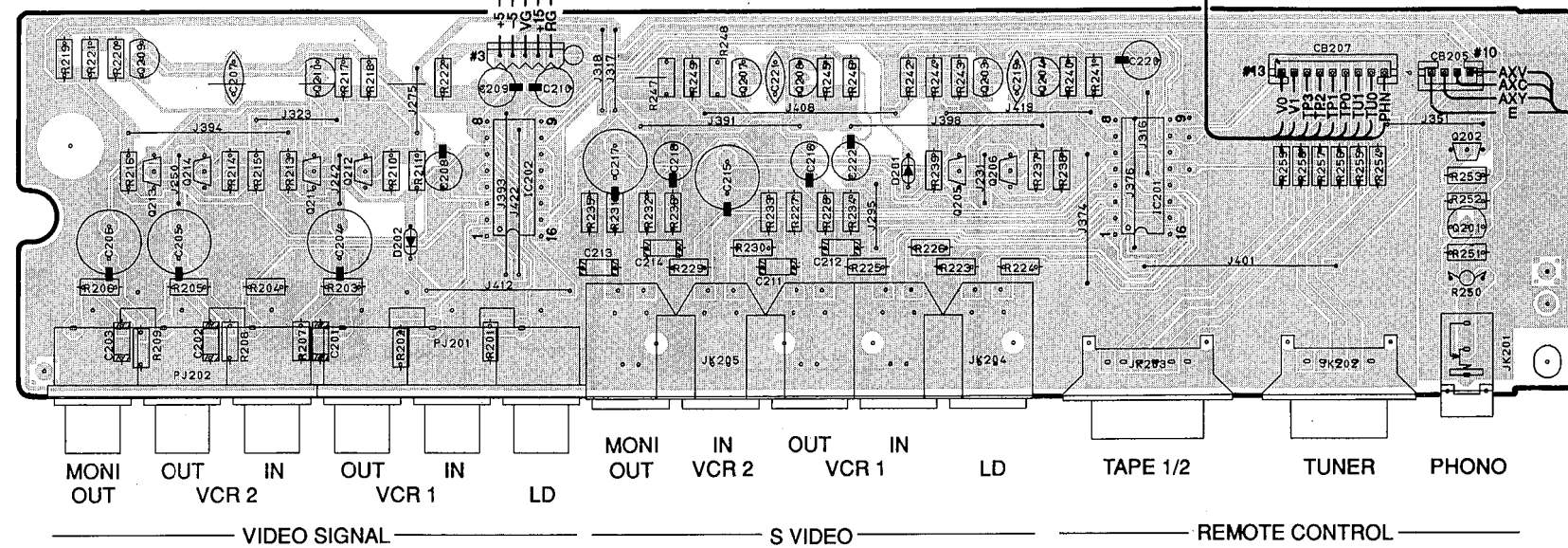

Task No.	Task	J	U, R	C	A, B	G
1	.C367 ~ 369	OPEN				0.01
2	.C345, 346, 370, 371	OPEN				0.022
3	.R447, 448, 474, 475	OPEN				2.2
4	.F201, 202	T6, OA125V				T4, OA250V
5	.RY201	DH24D2-φT(M) or JR2aD-DC24V or G5R-2232P		DH24D2-φT(M) or G5R-2232P	DH24D2-φT(M) or JR2aD-DC24V or G5R-2232P	
6	.TE201	VG74170				VG74160
7	.D230	4D4B41		RB402	4D4B41	
8	.D231	RBV-402LF-A		RBV-602LF-A	RBV-402LF-A	
9	.R510	2P 1.5K	2P 1.2K	2P 1K		
10	.C383, 384	VI98810	UM04847			
11	.C337, 338	VI98820	VI71140			
12	.J501	SHORT				OPEN
13	.J511	OPEN				SHORT
14	.C343, 344	OPEN				0.015
15	.C396	OPEN				0.033/100
16	.C397 ~ 399	OPEN				470P
17	.C400 ~ 402	OPEN				0.01
18	.C403, 404	OPEN				1
19	.C405 ~ 407	OPEN				68P
20	.C408 ~ 410	OPEN				220P
21	.C411	OPEN				1000P
22	.C394	0.1/25				OPEN
23	.R519	OPEN				1
24	.R520 ~ 522	OPEN				4.7
25	Ⓜ	NOT USE				USE

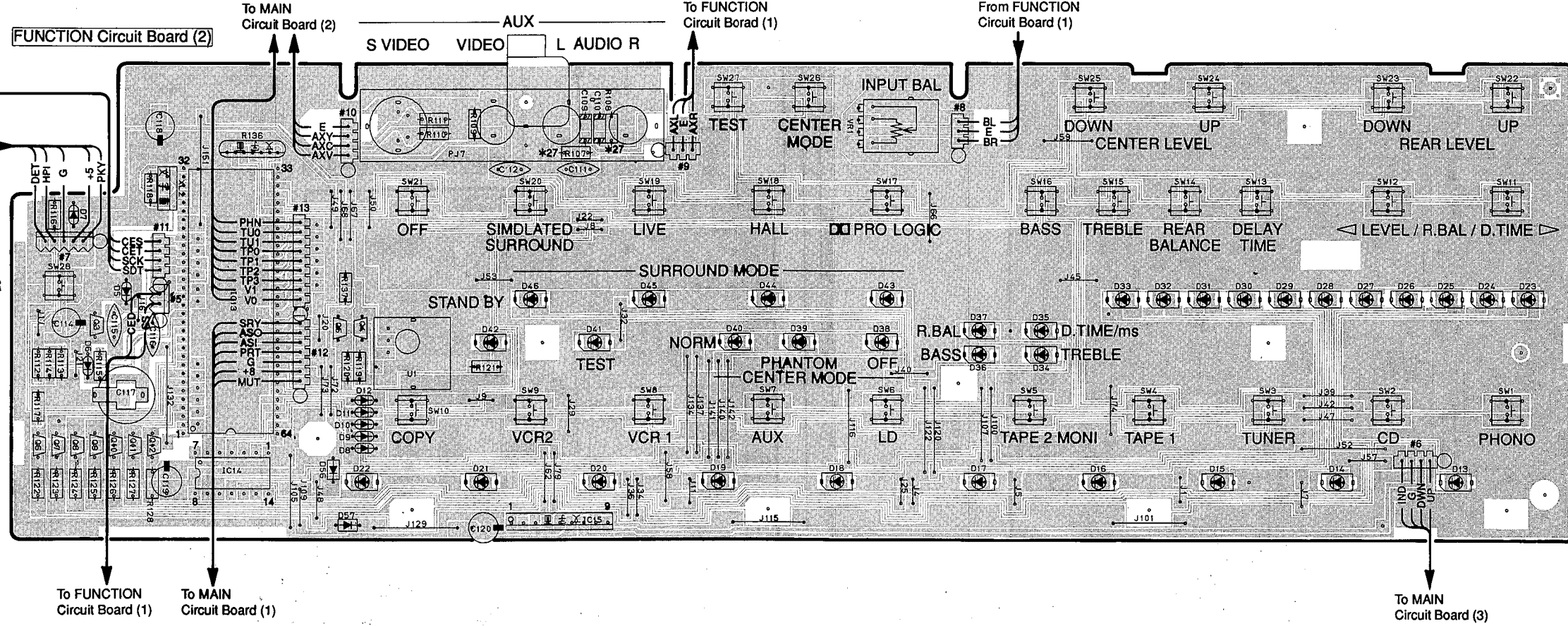

FUNCTION Circuit Board (4)

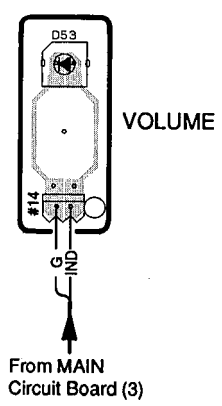

AVX-700

PRINTED CIRCUIT BOARD (Pattern side)

Notes) 文字面 : Component side

1
2
3
4
5
6
7

A B C D E F G H I J

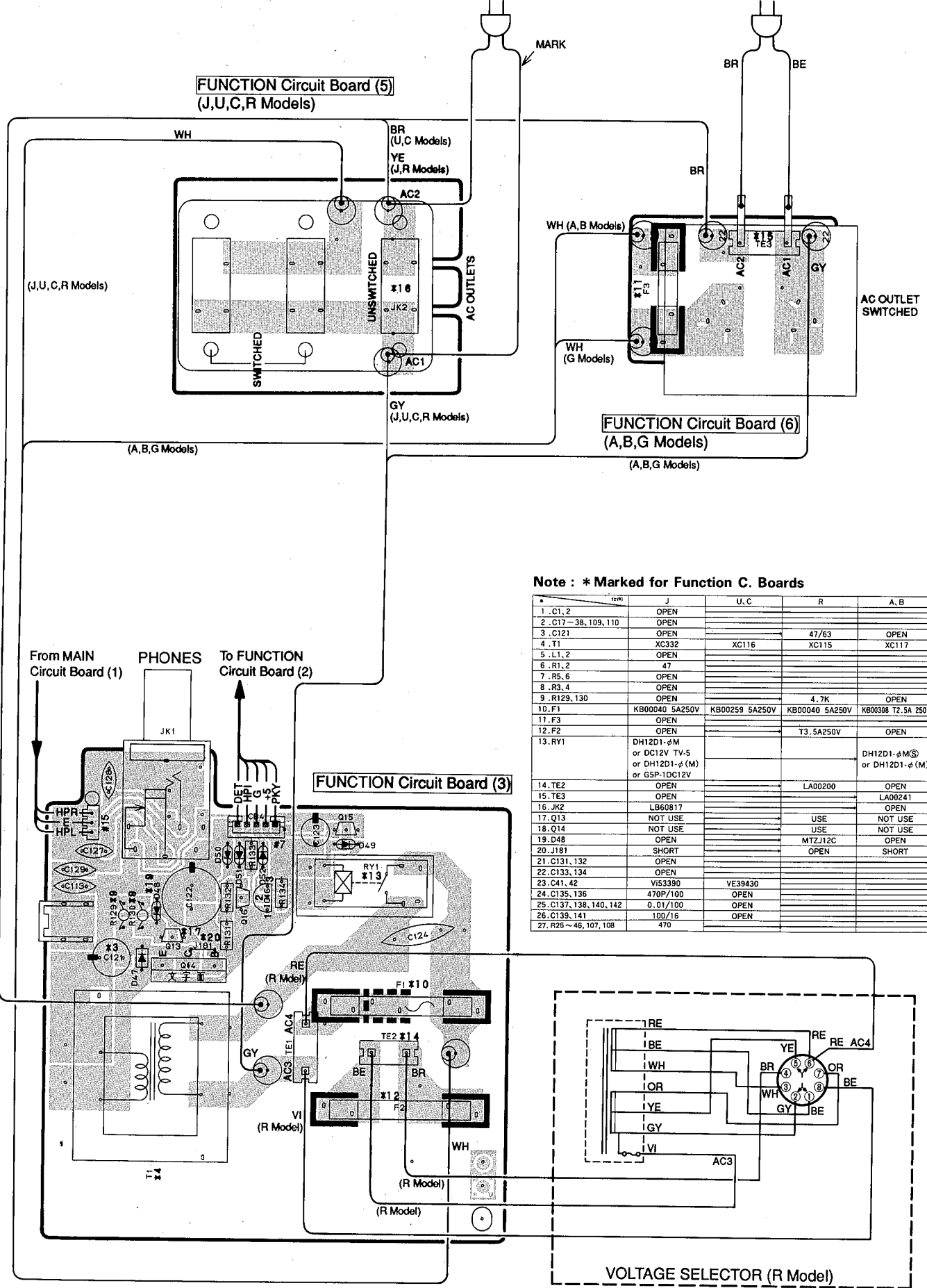
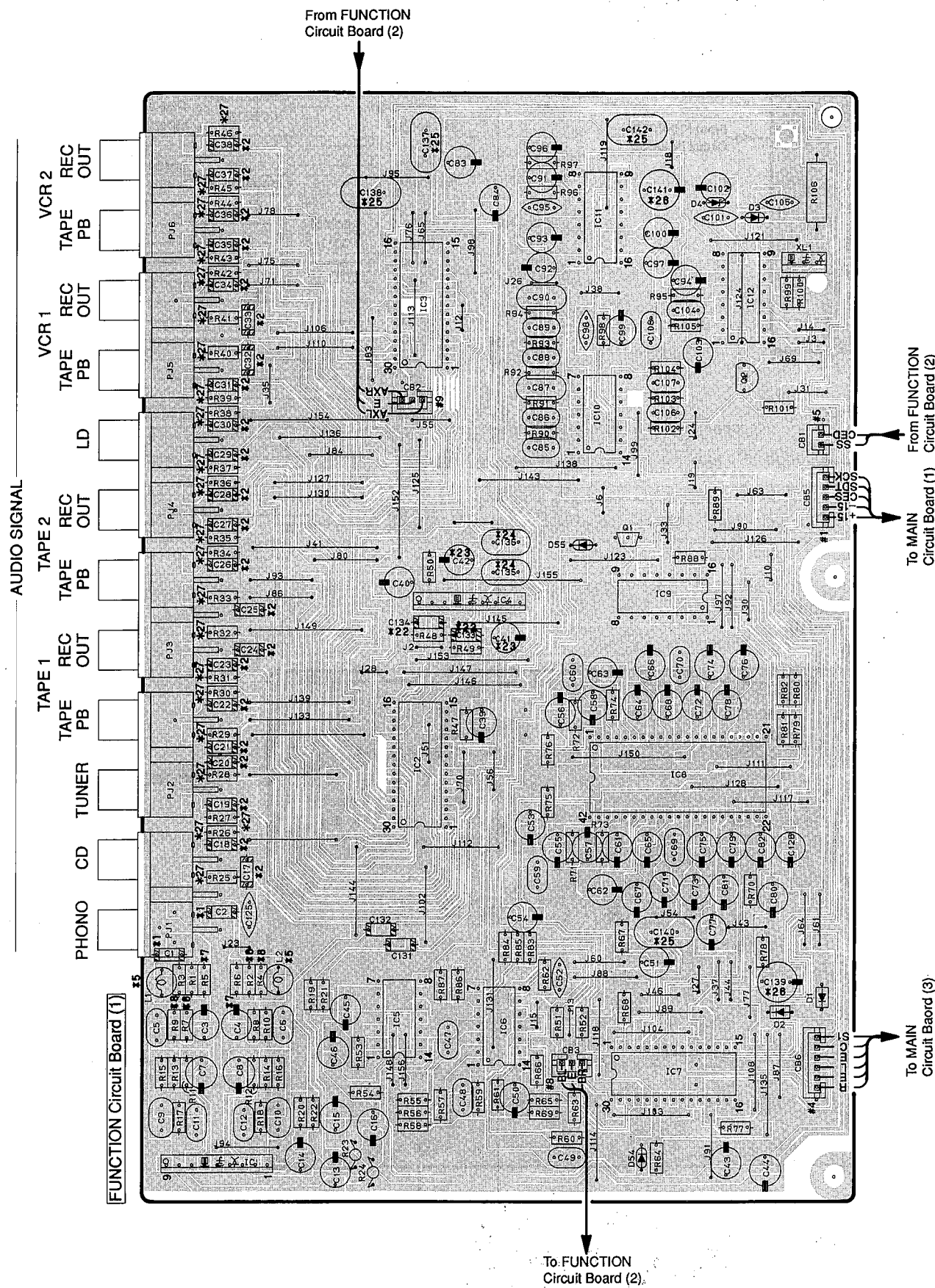

Note : * Marked for Function C. Boards

	J	U.C	R	A, B	G
1. C1. 2	OPEN				100P
2. C17-38, 109, 110	OPEN				470P
3. C121			47/63	OPEN	
4. T1	XC332	XC116	XC115	XC117	XC333
5. L1. 2	OPEN				220uH
6. R1. 2	47				OPEN
7. R5. 6	OPEN				47
8. R3. 4	OPEN				2.2K
9. R129, 130	OPEN		4.7K	OPEN	
10. F1	KB00040 5A250V	KB00259 5A250V	KB00040 5A250V	KB00208 T2.5A 250V	
11. F3	OPEN				T2.5A 250V
12. F2	OPEN		T3.5A250V	OPEN	
13. RY1	DH12D1-φM or DC12V TV-5 or DH12D1-φ(M) or G5P-10C12V			DH12D1-φM(S) or DH12D1-φ(M)	
14. TE2	OPEN		LA00200	OPEN	
15. TE3	OPEN			LA00241	
16. JK2	LB60817			OPEN	
17. Q13	NOT USE		USE	NOT USE	
18. Q14	NOT USE		USE	NOT USE	
19. D48	OPEN		MTZJ12C	OPEN	
20. J181	SHORT			SHORT	
21. C131, 132	OPEN				1000P
22. C133, 134	OPEN				220P
23. C41, 42	W33390	VE33430			
24. C135, 136	470P/100	OPEN			
25. C137, 138, 140, 142	0.01/100	OPEN			
26. C139, 141	100/16	OPEN			
27. R26-46, 107, 108	470				100

SCHEMATIC DIAGRAM

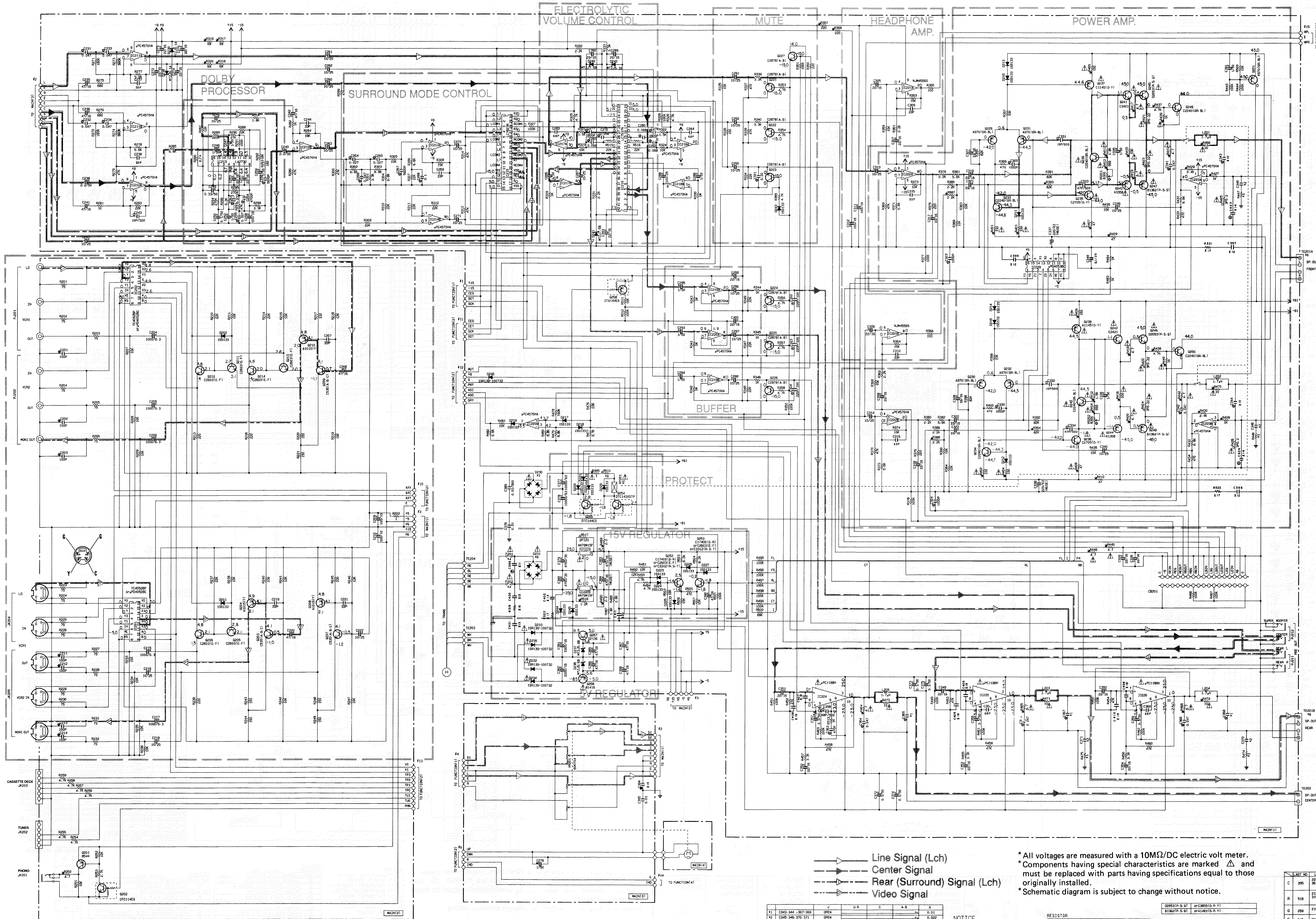

— Line Signal (Lch)
 — Center Signal
 — Rear (Surround) Signal (Lch)
 — Video Signal

* All voltages are measured with a 10MΩ/DC electric volt meter.
 * Components having special characteristics are marked Δ and must be replaced with parts having specifications equal to those originally installed.
 * Schematic diagram is subject to change without notice.

NO.	MARK	RESISTOR PARTS NAME	RESISTOR VALUE	REMARKS
R1	343-344	307-309	OPEN	
R2	345-346	370-371	OPEN	
R3	347	440-474	475	OPEN
R4	7201	202	10 0A125P	
R5	RV01		20K-0118	20K-0118
R6	TR01		0000-0000	0000-0000
R7	202P		0000-0000	0000-0000
R8	2031		0000-0000	0000-0000
R9	RV01		20K-0118	20K-0118

NOTICE
 (J)..... Japanese model
 (U)..... U.S.A model
 (C)..... Canadian model
 (A)..... Australian model
 (E)..... European model
 (B)..... British model
 (R)..... General model
 (P)..... RP model

NO.	MARK	CAPACITOR PARTS NAME	CAPACITOR VALUE	REMARKS
C1	343-344	307-309	OPEN	
C2	345-346	370-371	OPEN	
C3	347	440-474	475	OPEN
C4	7201	202	10 0A125P	
C5	RV01		20K-0118	20K-0118
C6	TR01		0000-0000	0000-0000
C7	202P		0000-0000	0000-0000
C8	2031		0000-0000	0000-0000
C9	RV01		20K-0118	20K-0118

CAPACITOR PARTS NAME
 NO MARK ELECTROLYTIC CAPACITOR
 CARBON FILM RESISTOR (1/4W)
 METAL OXIDE FILM RESISTOR
 METAL FILM RESISTOR
 FIBRE PROOF CARBON FILM RESISTOR
 SEMI VARIABLE RESISTOR
 CHIP RESISTOR

LAST NO.	UP. LISTED NO.
C	355
R	518
D	258
IC	209

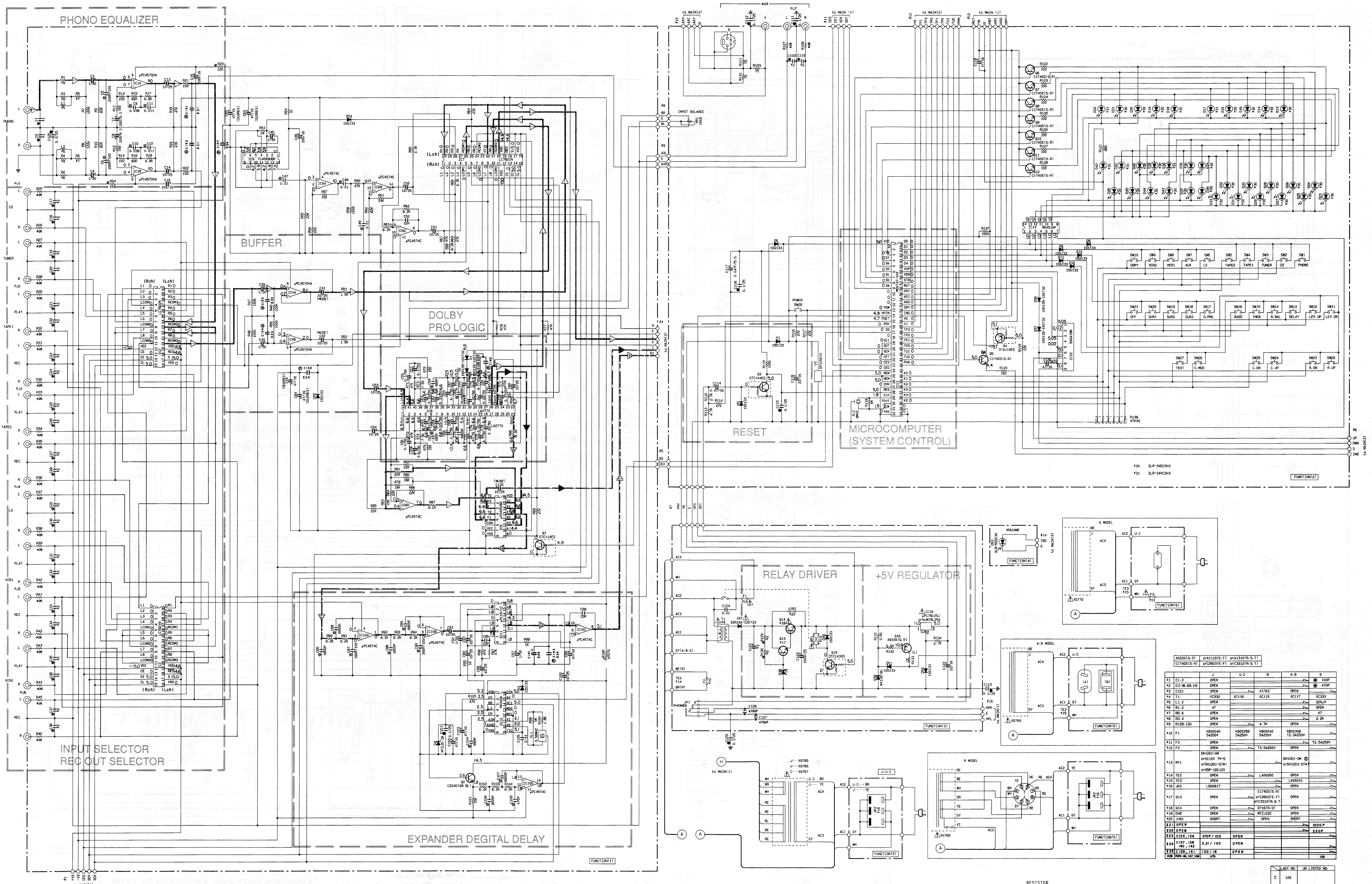

μPC4570HA	μPC4574C TC4069UBP	LA2770	LC7821N LC7822N LC7823N	M54516P	NJM4556S	AN79M15F	2SA935S (Q, R) 2SC2240 (R, BL) 2SD715 (R, O) 2SA970 (GR, BL) 2SA1015 (Y) 2SA1145 (O, Y) 2SB544	2SC2603 (E, F)	2SA1358 2SC3421	1SS133 1SR139-100T-32 MTZJ5.1B MTZJ6.8C MTZJ12C MTZJ5.6B MTZJ7.5B MTZJ9.1A	SLR-34DC3H3 SLR-55DC3H SLR-34VC3H3	RBV-402 RBV-602
μPC1571C TC4052BP	μPC76L05J	BA6418N	M50747-B86SP	μPC1188H	AN78M15F	LC7537N	2SC535 (A, B, C) 2SC2878 (A, B) 2SC2705 (O, Y)	2SB1416 2SD2136 (P, Q, R)	2SB1362 (P, S, Q) 2SD2053 (P, S, Q)	4D4B41 PB402		

* All voltages are measured with a 10MΩ/DC electric volt meter.
 * Components having special characteristics are marked **Δ** and must be replaced with parts having specifications equal to those originally installed.
 * Schematic diagram is subject to change without notice.

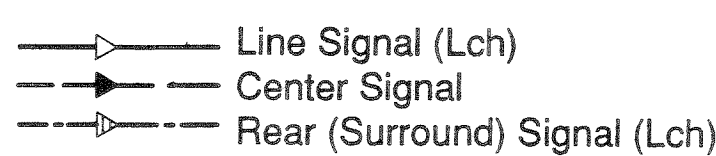

NOTICE
 (J)..... Japanese mode)
 (U)..... U.S.A mode)
 (C)..... Canadian mode)
 (A)..... Australian mode)
 (E)..... European mode)
 (B)..... British mode)
 (P)..... General mode)
 (P)..... PP mode)

RESISTOR	REMARKS	PARTS NAME	1/5W	1/4W
NO MARK		CARBON FILM RESISTOR		
Δ		METAL FILM RESISTOR		
⊠		METAL OXIDE FILM RESISTOR		
⊡		METAL PLATE RESISTOR		
⊞		FIRE PROOF CARBON FILM RESISTOR		
⊞		SEMI VARIABLE RESISTOR		
⊞		TRIMP RESISTOR		

CAPACITOR	REMARKS	PARTS NAME
NO MARK		CARBON FILM CAPACITOR
⊞		TANTALUM CAPACITOR
⊞		NO MARK CERAMIC CAPACITOR
⊞		POLYESTER FILM CAPACITOR
⊞		POLYSTYRENE FILM CAPACITOR
⊞		MYLA CAPACITOR
⊞		POLYPROPYLENE FILM CAPACITOR
⊞		SEMICONDUCTIVE CERAMIC CAPACITOR

IC	U-C	R	A-B	G
F1	OPEN			100P
F2	OPEN			470P
F3	OPEN	47/63	OPEN	RC333
F4	OPEN	AC115	AC117	RC333
F5	OPEN			200P
F6	OPEN			47
F7	OPEN			47
F8	OPEN			2.2K
F9	OPEN	4.7K	OPEN	
F10	OPEN	800040	800040	800038
F11	OPEN	800029	800040	72-8425V
F12	OPEN	T3-8425V	OPEN	T2-8425V
F13	OPEN			
F14	OPEN			
F15	OPEN			
F16	OPEN			
F17	OPEN			
F18	OPEN			
F19	OPEN			
F20	OPEN			
F21	OPEN			
F22	OPEN			
F23	OPEN			
F24	OPEN			
F25	OPEN			
F26	OPEN			

IC	U-C	R	A-B	G
C 129				
R 137				
G 16				
O 97				
IC 16				

PARTS LIST

AVX-700

■WARNING

Components having special characteristics are marked Δ and must be replaced with parts having specifications equal to those originally installed.

● Carbon resistors (1/6W or 1/4W) are not included in the ELECTRICAL PARTS list. For the parts No. of the carbon resistor, refer to p. 32.

■ ELECTRICAL PARTS

Ref. NO.	PART NO.	Description			部 品 名	Remarks	Markets	ランク
	Vi171200	MAIN CIRCUIT BOARD			メインシート		J	
	Vi171400	MAIN CIRCUIT BOARD			メインシート		UR	
	Vi171500	MAIN CIRCUIT BOARD			メインシート		C	
	Vi171600	MAIN CIRCUIT BOARD			メインシート		G	
	Vi432700	MAIN CIRCUIT BOARD			メインシート		AB	
	FA156100	MYLAR FILM CAP	1uF	50V	マイラーコン	C403,404	G	
	FA153100	MYLAR FILM CAP	1000pF	50V	マイラーコン	C323,324		
	FA153180	MYLAR FILM CAP	1800pF	50V	マイラーコン	C277,278		
	FA153470	MYLAR FILM CAP	4700pF	50V	マイラーコン	C254		
	FA153560	MYLAR FILM CAP	5600pF	50V	マイラーコン	C256,267		
	FA154100	MYLAR FILM CAP	0.01uF	50V	マイラーコン	C367-369	G	
	FA154150	MYLAR FILM CAP	0.015uF	50V	マイラーコン	C343,344	G	
	FA154270	MYLAR FILM CAP	0.027uF	50V	マイラーコン	C255,264,265		
	FA154330	MYLAR FILM CAP	0.033uF	50V	マイラーコン	C251		
	FA154470	MYLAR FILM CAP	0.047uF	50V	マイラーコン	C231-234,266,341,342,		
						364,365,366		
	FA154680	MYLAR FILM CAP	0.068uF	50V	マイラーコン	C279-282		
	FA155100	MYLAR FILM CAP	0.1uF	50V	マイラーコン	C268		
	FA155220	MYLAR FILM CAP	0.22uF	50V	マイラーコン	C301		
	UA252470	MYLAR FILM CAP	470pF	50V	マイラーコン	C363		
	UA253100	MYLAR FILM CAP	1000pF	50V	マイラーコン	C329,330		
	FT854330	POLYPROPYLENE FILM CAP	0.033uF	100V	PPコン	C396	G	
	UT452220	POLYPROPYLENE FILM CAP	220pF	100V	PPコン	C302-304		
	FG211220	CERAMIC CAP	22pF	50V	セラコン	C219,221		
	FG211330	CERAMIC CAP	33pF	50V	セラコン	C237,238,244,269,309,		
						310,315,316		
	FG211680	CERAMIC CAP	68pF	50V	セラコン	C283,284,359,360		
	FG212470	CERAMIC CAP	470pF	50V	セラコン	C397-399		
	FG212470	CERAMIC CAP	470pF	50V	セラコン	C397-399	G	
	Fi554100	CERAMIC CAP	0.01uF	50V	セラコン	C376,395		
	Fi554100	CERAMIC CAP	0.01uF	50V	セラコン	C400-402	G	
	FG244220	CERAMIC CAP	0.022uF	50V	セラコン	C345,346,370,371	G	
	VA302600	CERAMIC CAP	0.01uF	500V	セラコン	C389		
	VF466800	CERAMIC CAP	100pF	50V	円筒型セラコン	C201-203,211-214		
	VG277700	CERAMIC CAP	68pF	50V	円筒セラコン	C405-407	G	
	VG278400	CERAMIC CAP	220pF	50V	円筒セラコン	C408-410	G	
	VF467000	CERAMIC CAP	1000pF	50V	円筒セラコン	C411	G	
	VG286600	ELECTROLYTIC CAP	1000uF	6.3V	ケミコン	C204-206,215,217		
	VG286800	ELECTROLYTIC CAP	100uF	10V	ケミコン	C209,210		
	VG287300	ELECTROLYTIC CAP	22uF	16V	ケミコン	C253,257,272-275,289,		
						299,300,305-308,325,		
						326,349-354,392,393		
	VG287400	ELECTROLYTIC CAP	33uF	16V	ケミコン	C317-322,327,328		
	VG287500	ELECTROLYTIC CAP	47uF	16V	ケミコン	C208,220,235,236,241,		
						242,385-388,390		
	VG287600	ELECTROLYTIC CAP	100uF	16V	ケミコン	C258,311,312		
	VG288500	ELECTROLYTIC CAP	10uF	25V	ケミコン	C216,218,222,245,248,		
						260-263,270,271,287,		
						288,290-292,296-298,		
						313,314,339,340		

※New Parts (新規部品)

ランク : Japan only

AVX-700

Ref. NO.	PART NO.	Description	部 品 名	Remarks	Markets	ランク
	VG290000	ELECTROLYTIC CAP	0.1uF 50V	ケミコン	C250, 348, 372-375	
	VG290200	ELECTROLYTIC CAP	0.33uF 50V	ケミコン	C249	
	VG290500	ELECTROLYTIC CAP	1uF 50V	ケミコン	C246, 247, 252, 259, 285, 293-295, 335, 336, 391	286,
	VG290600	ELECTROLYTIC CAP	2.2uF 50V	ケミコン	C239, 240	
	VG290700	ELECTROLYTIC CAP	3.3uF 50V	ケミコン	C355-357	
	VG288100	ELECTROLYTIC CAP	2200uF 16V	ケミコン	C382	
	VG288200	ELECTROLYTIC CAP	3300uF 16V	ケミコン	C381	
	Vi988100	ELECTROLYTIC CAP	470uF 16V	ケミコン	C383, 384	J
	UM048470	ELECTROLYTIC CAP	470uF 16V	ケミコン	C383, 384	UCRABG
	Vi988200	ELECTROLYTIC CAP	220uF 63V	ケミコン	C337, 338	J
	Vi711400	ELECTROLYTIC CAP	220uF 63V	ケミコン	C337, 338	UCRABG
	VF679000	ELECTROLYTIC CAP	4700uF 35V	ケミコン	C379, 380	
	VF807300	ELECTROLYTIC CAP	10000uF 63V	ブロックケミコン	C377, 378	
	FM176100	ELECTROLYTIC CAP	1uF 50V	B Pケミコン	C276	
	FU351150	MICA CAP	15pF 500V	マイカコン	C331, 332	
	FH611100	CERAMIC CAP	10pF 500V	セラコン	C237, 238	
	FU351100	MICA CAP	10pF 500V	マイカコン	C243	
	FU351470	MICA CAP	47pF 500V	マイカコン	C333, 334, 358	
	VD930900	SEMI-CONDUCTIVE CAP	0.1uF 25V	半導体セラコン	C347, 394	
	GD900470	COIL	1.5uH RZ-001	空芯コイル	L201-205	
	HV453100	FLAME PROOF RESISTOR	1Ω 1/4W	不燃化カーボン抵抗	R485	
	HV453220	FLAME PROOF RESISTOR	2.2Ω 1/4W	不燃化カーボン抵抗	R489, 490	
	HV453470	FLAME PROOF RESISTOR	4.7Ω 1/4W	不燃化カーボン抵抗	R250, 417-420, 441, 442, 445, 446, 464-466	
	HV454100	FLAME PROOF RESISTOR	10Ω 1/4W	不燃化カーボン抵抗	R469-473	
	HV454470	FLAME PROOF RESISTOR	47Ω 1/4W	不燃化カーボン抵抗	R407-410	
	HV454680	FLAME PROOF RESISTOR	68Ω 1/4W	不燃化カーボン抵抗	R317-320	
	HV455150	FLAME PROOF RESISTOR	150Ω 1/4W	不燃化カーボン抵抗	R405, 406	
	HV455220	FLAME PROOF RESISTOR	220Ω 1/4W	不燃化カーボン抵抗	R367, 368	
	HV455330	FLAME PROOF RESISTOR	330Ω 1/4W	不燃化カーボン抵抗	R401-404, 415, 416	
	HV455560	FLAME PROOF RESISTOR	560Ω 1/4W	不燃化カーボン抵抗	R413, 414	
	HV456100	FLAME PROOF RESISTOR	1KΩ 1/4W	不燃化カーボン抵抗	R439, 440	
	HV456120	FLAME PROOF RESISTOR	1.2KΩ 1/4W	不燃化カーボン抵抗	R518	
	HV456180	FLAME PROOF RESISTOR	1.8KΩ 1/4W	不燃化カーボン抵抗	R411, 412	
	HV456470	FLAME PROOF RESISTOR	4.7KΩ 1/4W	不燃化カーボン抵抗	R437, 438	
	HU596100	METAL FILM RESISTOR	1KΩ 1/4W	金属皮膜抵抗	R427, 428	
	HU576220	METAL FILM RESISTOR	2.2KΩ 1/4W	金属皮膜抵抗	R387, 388	
	HU576240	METAL FILM RESISTOR	2.4KΩ 1/4W	金属皮膜抵抗	R429, 430	
	HU577820	METAL FILM RESISTOR	82KΩ 1/4W	金属皮膜抵抗	R393, 394	
	HL325120	METAL OXIDE RESISTOR	120Ω 2W	酸化金属被膜抵抗	R517	
	VD952400	METAL OXIDE RESISTOR	0.22Ω 3W	酸化金属被膜抵抗	R421-424	
	HL326150	METAL OXIDE RESISTOR	1.5KΩ 2W	酸化金抵抗	R510	J
	HL326120	METAL OXIDE RESISTOR	1.2KΩ 2W	酸化金属被膜抵抗	R510	UR
	HL326100	METAL OXIDE RESISTOR	1KΩ 2W	酸化金属被膜抵抗	R510	CABG
	VI470300	WIRE WOUND RESISTOR	0.2Ω 3W	セメント抵抗	R425, 426	
	IG102700	IC	uPC1188H	IC	IC224-226	
	IG077400	IC	NJM4556S	IC	IC221	
	XB247301	IC	uPC4570HA	IC	IC211, 212, 214, 217-220, 222, 223	
	XD386001	IC	LA2730	IC	IC213	

※New Parts (新規部品)

ランク : Japan only

Ref. NO.	PART NO.	Description	部 品 名	Remarks	Markets	ランク		
社	XB466001	IC	AN78M15F	IC	IC227		▲ ▲	
	XB467001	IC	AN79M15F	IC	IC228			
	XG758A00	IC	LC7823N	IC	IC215			
	iG105900	IC	uPD4053BC	IC	IC229			
	XA070A00	IC	uPD4052BC	IC	IC201,202			
社	XG554A00	IC	LC7537N	IC	IC216	ABG	▲ ▲ ▲	
	KB003100	FUSE	T4.0A 250V	ヒューズ	F201,202			JUCR
	KB003210	FUSE	T6.0A 125V	ヒューズ	F201,202			
	KC001940	RELAY	DH24D2-OT(M)	リレー	RY201			
	LA002320	LAPPING TERMINAL	3P i-TYPE P=7.5	ラッピング端子	TE203			
社	LA002340	LAPPING TERMINAL	5P i-TYPE P=7.5	ラッピング端子	TE204	JUCRAB G		
	Vi072400	SPEAKER TERMINAL	2P	ターミナル	TE202			
	VG741700	SPEAKER TERMINAL	8P	スピーカ端子	TE201			
	VG741600	SPEAKER TERMINAL	8P	スピーカ端子	TE201			
	VE991400	PIN JACK	3P	ピンジャック	PJ201,202			
社	Vi205900	PIN JACK	2P	ピンジャック	PJ211,212			
	LB100730	MINI JACK	S-G8036	ミニジャック	JK201			
	VH842600	S-CONNECTOR	2P	S コネクター	JK204			
	VH842700	S-CONNECTOR	3P	S コネクター	JK205			
	VD224100	SOCKET	34P	ソケット	CB201			
社	LB500710	SOCKET	5P W-P5505	STコネクターソケット	JK202			
	LB608390	SOCKET	6P W-P5506	STコネクターソケット	JK203			
	VD004500	BASE PIN	PH 2P TE	ベースピン	CB206			
	VD004600	BASE PIN	PH 3P TE	ベースピン	CB202			
	VD004700	BASE PIN	PH 4P TE	ベースピン	CB203-205			
社	VD004800	BASE PIN	PH 5P TE	ベースピン	CB208			
	VD005000	BASE PIN	PH 7P TE	ベースピン	CB209			
	VD005200	BASE PIN	PH 9P TE	ベースピン	CB207,210			
	VB860900	PRE-SET POTENTIOMETER	B330Ω RHO619	半固定VR	VR202,203			
	Vi219300	POTENTIOMETER WITH MOTOR	60KYx2,60KSx2	モーター付VR	VR201			
社	iA097000	TRANSISTOR	2SA970 GR,BL	トランジスタ	Q229-232,251		▲ ▲	
	iA101521	TRANSISTOR	2SA1015 Y	トランジスタ	Q204,208,210			
	iA114500	TRANSISTOR	2SA1145 O,Y	トランジスタ	Q237,238			
	iB054410	TRANSISTOR	2SB544	トランジスタ	Q201			
	Vi206000	TRANSISTOR	2SB1416	トランジスタ	Q256			
社	iC053540	TRANSISTOR	2SC535 A,B,C	トランジスタ	Q203,207,209	250	▲ ▲	
	iC260310	TRANSISTOR	2SC2603 E,F	トランジスタ	Q252,253			
	iC224000	TRANSISTOR	2SC2240 GR,BL	トランジスタ	Q233,234,239,240,249,			
	iC260310	TRANSISTOR	2SC2603 E,F	トランジスタ	Q205,206,211-214			
	iC287820	TRANSISTOR	2SC2878 A,B	トランジスタ	Q221-227			
	VE198800	TRANSISTOR	2SC2705 O,Y	トランジスタ	Q235,236			
社	Vi206100	TRANSISTOR	2SD2136 P,Q,R	トランジスタ	Q257		▲ ▲ ▲ ▲ ▲	
	iX603580	TRANSISTOR	2SA1358	トランジスタ	Q243,244			
	iX603590	TRANSISTOR	2SC3421	トランジスタ	Q241,242			
	iX611040	TRANSISTOR	2SB1362 P,S,Q	トランジスタ	Q247,248			
	iX611050	TRANSISTOR	2SD2053 P,S,Q	トランジスタ	Q245,246			
社	iF004600	DIODE	1SS133	ダイオード	D201,202,211-227,229,	243-245	▲ ▲ ▲ ▲	
	VH770800	DIODE	1SR139-100 T-32	ダイオード	D232-235,246			
	iH001160	DIODE BRIDGE	4D4B41	ダイオードブリッジ	D230			JURAB C
	iH001040	DIODE BRIDGE	RB402	ダイオードブリッジ	D230			

*New Parts (新規部品)

ランク : Japan only

AVX-700

Ref. NO.	PART NO.	Description	部 品 名	Remarks	Markets	ランク	
*	VH348200	DIODE BRIDGE	RBV-402 LF-A	ダイオードブリッジ	D231	JURAB	▲
	Vi711600	DIODE BRIDGE	RBV-602 LF-A	ダイオードブリッジ	C231	C	
	VG437400	ZENER DIODE	MTZJ5.1B	ツェナーダイオード	D242		
	VG437700	ZENER DIODE	MTZJ5.6B	ツェナーダイオード	D236, 237		
	VG438600	ZENER DIODE	MTZJ7.5B	ツェナーダイオード	D240, 241		
*	VG439100	ZENER DIODE	MTZJ9.1A	ツェナーダイオード	D238, 239		
	VD488500	DIGITAL TRANSISTOR	DTC143XS	デジタルトランジスタ	Q254		
	VD678700	DIGITAL TRANSISTOR	DTC114ES	デジタルトランジスタ	Q202		
	VG721700	DIGITAL TRANSISTOR	DTA144ES	デジタルトランジスタ	Q258		
	LB201880	FUSE HOLDER PIN	PC-FH1	ヒューズホルダピン			
	BA092970	RADIATOR	OSH-2425-SP	放熱器			
	BB069510	GROUND PLATE		ランド金具			
	ED330086	BINDING HEAD SCREW	3x8 FCRM3-BL	バインド小ネジ	PACK		
*	Vi170200	FUNCTION CIRCUIT BOARD		ファンクションシート		J	
	Vi170300	FUNCTION CIRCUIT BOARD		ファンクションシート		UC	
	Vi170400	FUNCTION CIRCUIT BOARD		ファンクションシート		R	
	Vi170500	FUNCTION CIRCUIT BOARD		ファンクションシート		AB	
	Vi170600	FUNCTION CIRCUIT BOARD		ファンクションシート		G	
	UA252470	MYLAR FILM CAP	470pF 50V	マイラーコン	C108		
	UA252680	MYLAR FILM CAP	680pF 50V	マイラーコン	C59, 60, 104		
	FA153180	MYLAR FILM CAP	1800pF 50V	マイラーコン	C85, 88		
	FA153300	MYLAR FILM CAP	3000pF 50V	マイラーコン	C106		
	FA153880	MYLAR FILM CAP	6800pF 50V	マイラーコン	C69, 70, 86, 89, 107		
	FA154100	MYLAR FILM CAP	0.01uF 50V	マイラーコン	C47-49		
	FA154110	MYLAR FILM CAP	0.011uF 50V	マイラーコン	C11, 12		
	FA154390	MYLAR FILM CAP	0.039uF 50V	マイラーコン	C9, 10		
	UT452220	POLYPROPYLENE FILM CAP	220pF 100V	PPコン	C5, 6		
	UT452390	POLYPROPYLENE FILM CAP	390pF 100V	PPコン	C87, 90		
	Fi191100	CERAMIC CAP	10pF 50V (CH)	セラコン	C52		
	Fi191330	CERAMIC CAP	33pF 50V (CH)	セラコン	C95, 98		
	FG213470	CERAMIC CAP	4700pF 50V	セラコン	C127, 128		
	Fi554100	CERAMIC CAP	0.01uF 50V	セラコン	C105		
	VF466800	CERAMIC CAP	100pF 50V	円筒型セラコン	C1, 2	G	
	VG278400	CERAMIC CAP	220pF 50V	円筒型セラコン	C133, 134	G	
	VF466900	CERAMIC CAP	470pF 50V	円筒型セラコン	C17-38, 109, 110		
	VF467000	CERAMIC CAP	1000pF 50V	円筒型セラコン	C131, 132	G	
	VD930900	SEMI-CONDUCTIVE CAP	0.1uF 25V	半導体セラコン	C101, 111-113, 115, 116	125, 129	
	UW565150	ELECTROLYTIC CAP	0.15uF 50V	ケミコン	C63, 64		
	Ui1377470	ELECTROLYTIC CAP	47uF 63V	ケミコン	C121	R	
	UM397220	ELECTROLYTIC CAP	22uF 16V	ケミコン	C118		
	UM397470	ELECTROLYTIC CAP	47uF 16V	ケミコン	C119, 120		
	UM415470	ELECTROLYTIC CAP	0.47uF 50V	ケミコン	C114		
	VG286300	ELECTROLYTIC CAP	220uF 6.3V	ケミコン	C7, 8		

*New Parts (新規部品)

ランク : Japan only

Ref. NO.	PART NO.	Description			部 品 名	Remarks	Markets	ランク
	VG286700	ELECTROLYTIC CAP	47uF	10V	ケミコン	C99,102,103		
	VG287300	ELECTROLYTIC CAP	22uF	16V	ケミコン	C93,123		
	VG287500	ELECTROLYTIC CAP	47uF	16V	ケミコン	C71,72,81		
	VG287600	ELECTROLYTIC CAP	100uF	16V	ケミコン	C15,16,46		
	VG288500	ELECTROLYTIC CAP	10uF	25V	ケミコン	C13,14,50,51,53,54,79,		
	VG290000	ELECTROLYTIC CAP	0.1uF	50V	ケミコン	80,91,94,96,100 C55-58		
	VG290100	ELECTROLYTIC CAP	0.22uF	50V	ケミコン	C73,74,77,78		
	VG290200	ELECTROLYTIC CAP	0.33uF	50V	ケミコン	C61,62		
	VG290300	ELECTROLYTIC CAP	0.47uF	50V	ケミコン	C82		
	VG290500	ELECTROLYTIC CAP	1uF	50V	ケミコン	C3,4,39,40,45,92,97		
	VG290800	ELECTROLYTIC CAP	4.7uF	50V	ケミコン	C65-68,75,76		
	VE017800	ELECTROLYTIC CAP	47uF	16V	ケミコン	C43,44,83,84		
	VE394200	ELECTROLYTIC CAP	10uF	25V	ケミコン	C126		
*	Vi533900	ELECTROLYTIC CAP	22uF	25V	ケミコン	C41,42	J	
	VE394300	ELECTROLYTIC CAP	22uF	25V	ケミコン	C41,42	UCRABG	
	UH149100	ELECTROLYTIC CAP	1000uF	25V	ケミコン	C122		
	Fi514100	CERAMIC CAP	0.01uF	VA-1	スパークキラーコン	C124		
	VE632800	ELECTROLYTIC CAP	0.047F	5.5V	スーパーキャパシタ	C117		
	XC115001	POWER TRANSFORMER			電源トランス		R	⚠
	XC116001	POWER TRANSFORMER			電源トランス		UC	⚠
	XC117001	POWER TRANSFORMER			電源トランス		AB	⚠
	XC332001	POWER TRANSFORMER			電源トランス		J	⚠
	XC333001	POWER TRANSFORMER			電源トランス		G	⚠
	VA983600	COIL	220uH	ELF0505SKI	コイル	L1,2	G	
	HV455100	FLAME PROOF RESISTOR	100Ω	1/4W	不燃化カーボン抵抗	R23,24		
	HV456470	FLAME PROOF RESISTOR	4.7KΩ	1/4W	不燃化カーボン抵抗	R129,130	R	
	HL315270	METAL OXIDE RESISTOR	270Ω	1W	酸化金属被膜抵抗	R106		
	VE340500	RESISTOR ARRAY	47KΩ×6		抵抗アレイ	R136		
	XB247301	IC	uPC4570HA		IC	IC1,4		
	XE387001	IC	uPC1571C		IC	IC11		
	XF971A00	IC	uPC4574C		IC	IC6,10		
	XC349001	IC	uPC78L05J		IC	IC16		⚠
	XG497A00	IC	LA2770		IC	IC8		
	XG755A00	IC	BA6418N		IC	IC15		
*	XG732A00	IC	LC7821N		IC	IC3,7		
	XG757A00	IC	LC7822N		IC	IC2		
*	XA070A00	IC	uPD4052BC		IC	IC9		
	iG001720	IC	TC4069UBP		IC	IC5		
*	XG553A00	IC	M50747-B86SP		IC	IC13		
	XE817001	IC	YM3428		IC	IC12		
	iG031100	IC	M54516P		IC	IC14		
	VF926500	RECEIVE UNIT	GP1U501X		リモコン受光ユニット	U1		
	VE327300	PUSH SWITCH	KHH-MA901		プッシュSW	SW1-28		
	KB002590	FUSE	T5.0A	250V	ヒューズ	F1	UC	⚠
	KB000400	FUSE	T5.0A	250V	ヒューズ	F1	JR	⚠
	KB003080	FUSE	T2.5A	250V	ヒューズ	F1	ABG	⚠
	KB003080	FUSE	T2.5A	250V	ヒューズ	F3	G	⚠
	KB000370	FUSE	T3.5A	250V	ヒューズ	F2	R	⚠
	KC001910	RELAY	DH12D1-0M		リレー	RY1	JUCR	⚠

*New Parts (新規部品)

ランク : Japan only

Ref. NO.	PART NO.	Description	部 品 名	Remarks	Markets	ランク	
	VE568900	RELAY	DH12D1-0(M)	リレー	RY1	ABG	▲
	LA002140	LAPPING TERMINAL	2P i-TYPE P=10	ラッピング端子	TE1		
	LA002000	LAPPING TERMINAL	2P i-TYPE P=7.5	ラッピング端子	TE2	R	
	LA002410	LAPPING TERMINAL	2P L-TYPE P=10	ラッピング端子	TE3	ABG	
	LB401070	PIN JACK	4P T5857-A	ピンジャック	PJ2,4-6		
	LB401090	PIN JACK	4P T5858-AABC	ピンジャック	PJ3		JUCR
	LB401100	PIN JACK	4P T5859-A	ピンジャック	PJ1		
	VF227900	PHONES JACK	M1659-AHAA	ホーンジャック	JK1		
	LB608170	AC OUTLET	3P M7032D	ACアウトレット	JK2		
	VH843100	JACK PLATE	TCXC146	ジャック板	PJ7		
	VD004500	BASE PIN	PH 2P TE	ベースピン	CB1		
	VD004600	BASE PIN	PH 3P TE	ベースピン	CB2,3		
	VD004800	BASE PIN	PH 5P TE	ベースピン	CB4,5		
	VD004900	BASE PIN	PH 6P TE	ベースピン	CB6		
	VE222400	CERAMIC RESONATOR	8MHz EFO-FC800	セラミック発振子	XL2		
	VF071000	CERAMIC RESONATOR	3.5MHz	セラミック振動子	XL1		R
	VH843000	POTENTIOMETER	B10K	ロータリーVR	VR1		
	iA093370	TRANSISTOR	2SA933S Q,R	トランジスタ	Q16		
	iC280310	TRANSISTOR	2SC2803 E,F	トランジスタ	Q5-12		
	iC280310	TRANSISTOR	2SC2803 E,F	トランジスタ	Q13		
	iC224000	TRANSISTOR	2SC2240 GR,BL	トランジスタ	Q2		R
	iD071610	TRANSISTOR	2SD716 R,O	トランジスタ	Q14		
	iF004600	DIODE	1SS133	ダイオード	D3,5-12,49,51,52,54,55		
	VH770800	DIODE	1SR139-100 T-32	ダイオード	D1,2,47,56,57		
	VG437400	ZENER DIODE	MTZJ5.1B	ツェナーダイオード	D4		
	VG438400	ZENER DIODE	MTZJ6.8C	ツェナーダイオード	D50		R
	VG440300	ZENER DIODE	MTZJ12C	ツェナーダイオード	D48		
	VF402500	LED	SLR-34DC3H3 (ORA)	L E D	D13-16,18-21,23-37,39,	40,43-46	
	VH293600	LED	SLR-55DC3H (ORA)	L E D	D53		
	Vi013600	LED	SLR-34VC3H3 (RED)	L E D	D17,22,38,41,42		
	VG722000	DIGITAL TRANSISTOR	DTC144ES	デジタルトランジスタ	Q3		
	VD488500	DIGITAL TRANSISTOR	DTC143XS	デジタルトランジスタ	Q15		
	VD678500	DIGITAL TRANSISTOR	DTA114ES	デジタルトランジスタ	Q4		
	VD678700	DIGITAL TRANSISTOR	DTC114ES	デジタルトランジスタ	Q1		
	LB201880	FUSE HOLDER PIN	PC-FH1	ヒューズホルダーピン			
	Vi051600	GROUND PLATE		アースプレート			
	BB071360	TERMINAL,SCREW	8.3x13	ネジ端子			

*New Parts (新規部品)

ランク : Japan only

EXPLODED VIEW

1

2

3

4

5

6

7

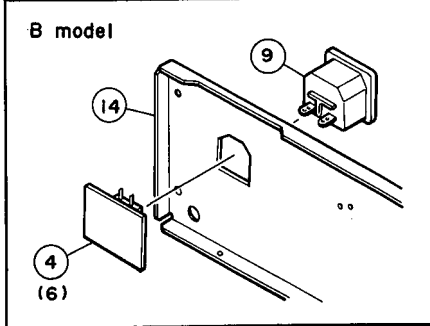
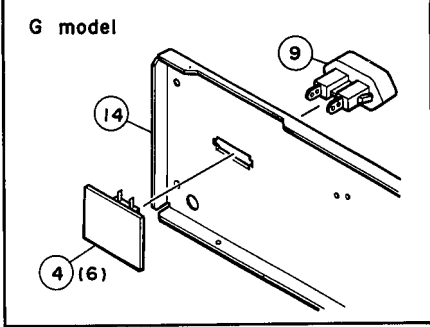
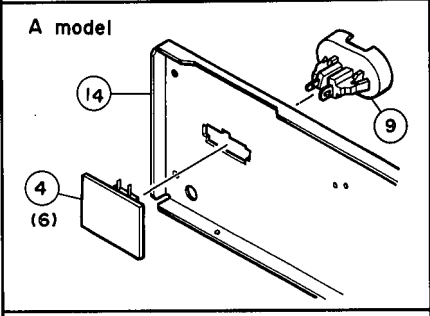
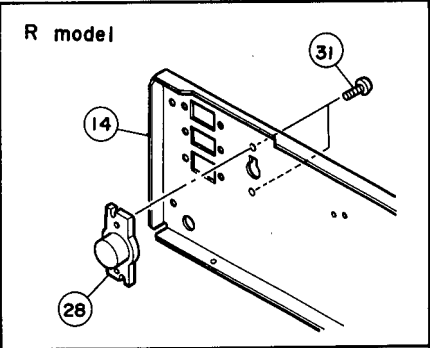
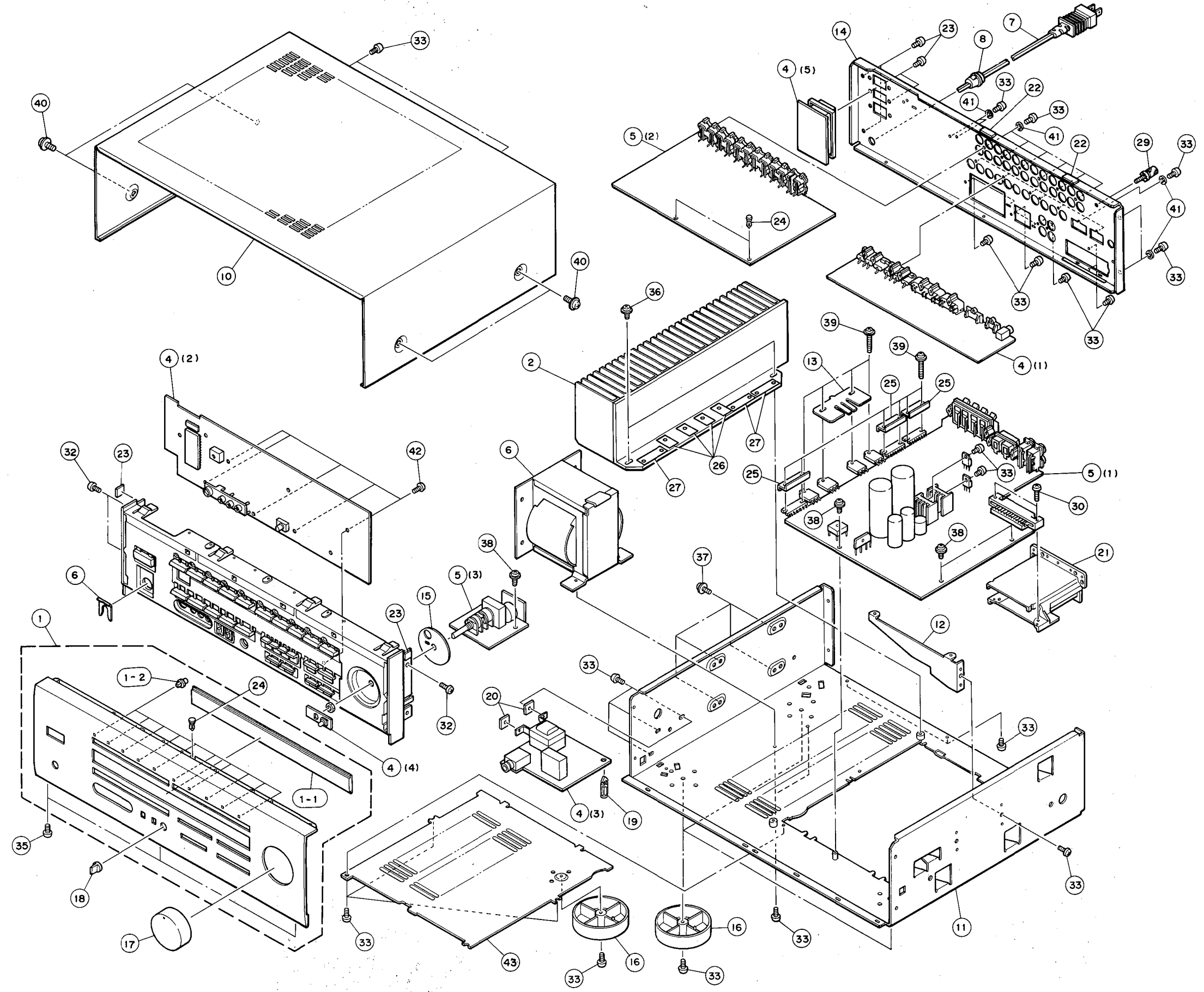

MECHANISM PARTS

Ref. NO.	PART NO.	Description	部 品 名	Remarks	Markets	ランク
* 01	Vi169300	PANEL UNIT	パネルユニット	BL	J	
* 01	Vi169500	PANEL UNIT	パネルユニット	T	J	
* 01	Vi169400	PANEL UNIT	パネルユニット	BL	UCRABG	
* 01	Vi169600	PANEL UNIT	パネルユニット	T	UCRABG	
* 01-1	Vi051000	WINDOW	ウインドウ	BL		
* 01-1	Vi051100	WINDOW	ウインドウ	T		
* 01-2	VH897600	LENS	レンズ			2.2S
* 02	Vi050500	RADIATOR	ラジエータ			
* 04	Vi170200	FUNCTION CIRCUIT BOARD	ファンクションシート		J	
* 04	Vi170300	FUNCTION CIRCUIT BOARD	ファンクションシート		UC	
* 04	Vi170400	FUNCTION CIRCUIT BOARD	ファンクションシート		R	
* 04	Vi170500	FUNCTION CIRCUIT BOARD	ファンクションシート		AB	
* 04	Vi170600	FUNCTION CIRCUIT BOARD	ファンクションシート		G	
* 05	Vi171200	MAIN CIRCUIT BOARD	メインシート		J	
* 05	Vi171400	MAIN CIRCUIT BOARD	メインシート		UR	
* 05	Vi171500	MAIN CIRCUIT BOARD	メインシート		C	
* 05	Vi171600	MAIN CIRCUIT BOARD	メインシート		G	
* 05	Vi432700	MAIN CIRCUIT BOARD	メインシート		AB	
* 06	XG765A00	POWER TRANSFORMER	電源トランス		J	
* 06	XG766A00	POWER TRANSFORMER	電源トランス		U	
* 06	XG767A00	POWER TRANSFORMER	電源トランス		C	
* 06	XG768A00	POWER TRANSFORMER	電源トランス		R	
* 06	XG769A00	POWER TRANSFORMER	電源トランス		AB	
* 06	XG770A00	POWER TRANSFORMER	電源トランス		G	
* 07	MG001210	POWER CORD	電源コード		J	15A 125V 2m
* 07	MG002220	POWER CORD	電源コード		UC	10A 125V
* 07	MG001630	POWER CORD	電源コード		R	6A 250V 2m
* 07	MG002130	POWER CORD	電源コード		A	7.5A 250V
* 07	MG002320	POWER CORD	電源コード		G	2.5A 250V
* 07	MG002330	POWER CORD	電源コード		B	6A 300V
* 08	CB620190	CORD STOPPER	コードストッパー		RABG	CM-22B
* 08	CB620200	CORD STOPPER	コードストッパー		JUC	CM-22C
* 09	VC626100	AC OUTLET	ACアウトレット		A	2P S2-739T
* 09	VC627000	AC OUTLET	ACアウトレット		B	2P CM-20
* 09	VC626800	AC OUTLET	ACアウトレット		G	2P CM-31
* 10	VG937100	TOP COVER	トップカバー	BL		
* 10	VG937200	TOP COVER	トップカバー	T		
* 10	VH962700	TOP COVER ASS'Y	トップカバー-ASSY	BL	G	
* 10	VH962800	TOP COVER ASS'Y	トップカバー-ASSY	T	G	
* 11	Vi051700	CHASSIS	シャーシ			
* 12	VG937500	SUPPORT	サポート			P
* 13	Vi050800	FRAME	フレーム			TR
* 14	Vi049900	REAR PANEL	リヤパネル		J	
* 14	Vi050000	REAR PANEL	リヤパネル		R	
* 14	Vi050100	REAR PANEL	リヤパネル		UC	
* 14	Vi050200	REAR PANEL	リヤパネル		A	
* 14	Vi050300	REAR PANEL	リヤパネル		G	
* 14	Vi050400	REAR PANEL	リヤパネル		B	
* 15	VH087800	SHIELD PLATE	シールドプレート			
* 16	CB600950	LEG	レッグ	BL	UCRABG	

*New Parts (新規部品)

ランク : Japan only

Ref. NO.	PART NO.	Description	部 品 名	Remarks	Markets	ランク
16	Vi175700	LEG	レッグ	T	UCRABG	
* 16	Vi615200	LEG	レッグ		J	
* 17	Vi051200	KNOB,D45	ノブ D45	LED	BL	
* 17	Vi051300	KNOB,D45	ノブ D45	LED	T	
* 18	Vi051400	KNOB,D10	ノブ D10		BL	
* 18	Vi051500	KNOB,D10	ノブ D10		T	
* 19	Vi176000	SPACER	スペーサ			
* 20	Vi707300	DAMPER	ダンパー			
* 21	Vi176100	BOX ASS'Y	ボックスASSY			
* 22	VG812800	DAMPER	ダンパー	2x15x6		
* 23	VH625500	DAMPER	ダンパー			
* 24	CB605620	PLASTIC RIVET	プラリベット			
* 25	Vi801600	FRAME, IC	フレームIC			
* 26	Vi071100	SHEET,RADIATOR	放熱シート	20x22		
* 27	Vi071200	SHEET,RADIATOR	放熱シート	34x15		
* 28	Vi449800	VOLTAGE SELECTOR	電圧切替器	ESE-37284-F		R
* 29	AA627310	GROUND TERMINAL	GNDターミナル	3x13 FNM3-3G		
* 30	Ei330166	BINDING HEAD TAPPING SCREW	バインドタッピングネジ	3x16 FCM3-BL	PACK	
* 31	ED330066	BINDING HEAD SCREW	バインド小ネジ	3x6 FCM3-BL	PACK	
* 32	EO330066	FLAT HEAD B-TYTE SCREW	皿Bタイトネジ	3x6 FCM3-BL	PACK	
* 33	Ei330086	BINDING HEAD TAPPING SCREW	バインドタッピングネジ	3x8 FCM3-BL	PACK	
* 35	Ei330106	BIND HEAD TAPPING SCREW	バインドタッピングネジ	3x10	PACK	
* 36	EX600240	BW HEAD TAPPING SCREW	BWヘッドタッピングネジ	3x8-10 FCM3-BL		
* 37	Ei340806	BINDING HEAD TAPPING SCREW	バインドBタイトネジ	4x8 FCM3-BL	PACK	
* 38	EK336020	BW HEAD TAPPING SCREW	BWヘッドタッピングネジ	3x6 FCM3-BL		
* 39	EX600250	CUP TIGHT SCREW	カップBタイトネジ	3x10 FCM3-BL		
* 40	EK365040	BW HEAD SCREW	BWネジ	4x8-10 FCM3-BL	BL	
* 40	EX601150	BW HEAD SCREW	BWネジ	4x8-10 FNM3-BL	T	
* 41	EV413036	TOOTHED LOCK WASHER	歯付き座金	M3 FCM3-BL	PACK	
* 42	EJ326086	PAN HEAD TAPPING SCREW	ナベタッピングネジ	2.6x8 FCM3-BL	PACK	
* 43	AX608290	BOTTOM COVER	ボトムカバー			
	CB069250	BINDING TIE	束線止め	BK-1		
		ACCESSORIES	付属品			
* 16	Vi217700	REMOTE CONTROL TRANSMITTER	リモコン		JUCRA	
* 16	Vi217800	REMOTE CONTROL TRANSMITTER	リモコン		BG	
	VB308200	PIN PLUG CORD	ピンプラグコード	1P 2m		
	Ni081780	CORD WITH MINI PLUG	ミニプラグコード	1.2m		
	VB308300	ST CONNECTOR	STコネクタ	5P 1m (TUNER)		
	VB308400	ST CONNECTOR	STコネクタ	6P 1m (DECK)		
		DRY CELL	乾電池	SUM-3,AA,R6	JUCRA	
		DRY CELL	乾電池	R03	BG	

*New Parts (新規部品)

ランク : Japan only

EXPLODED VIEW

- U.S.A., Canadian, Australian and General models

1

2

3

4

5

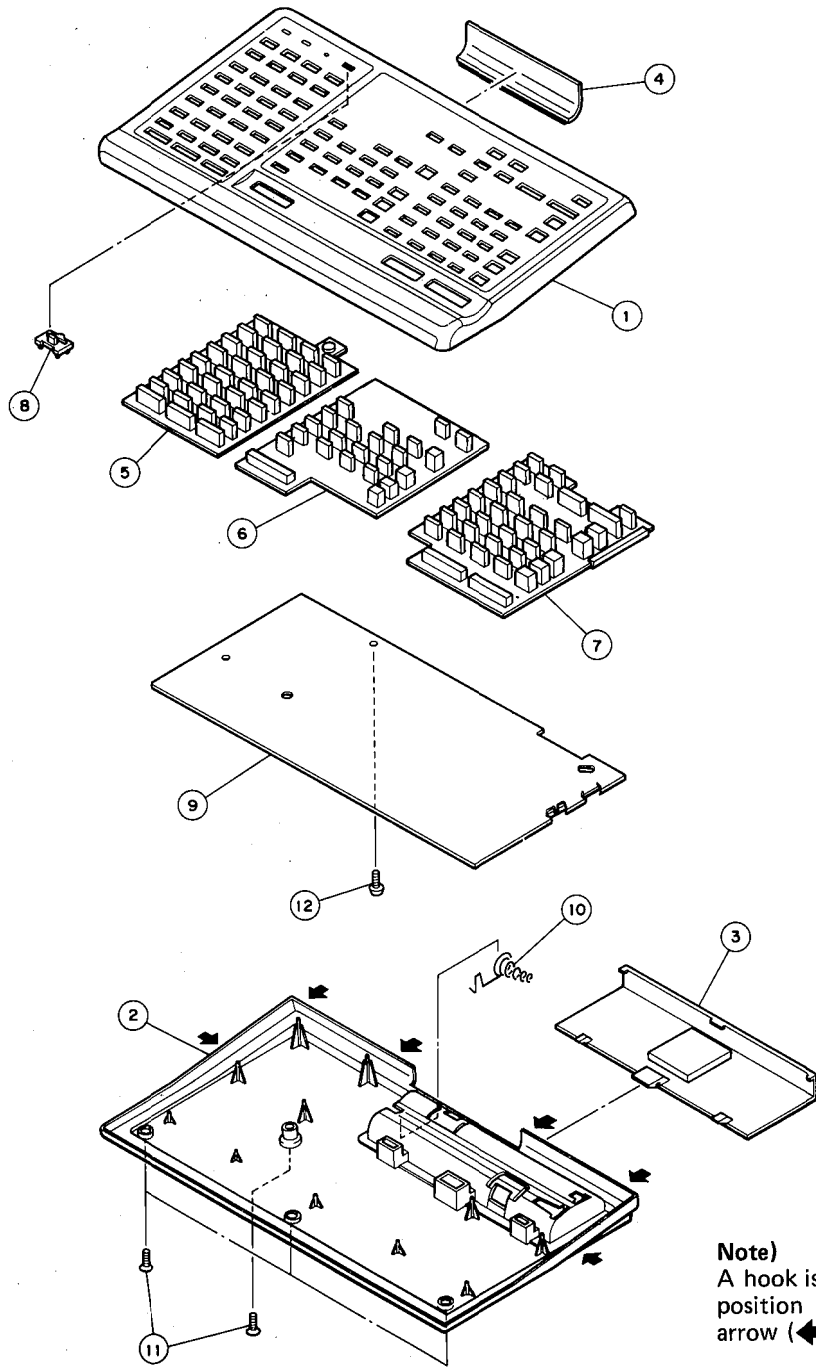

Note)
A hook is provided at each position marked with an arrow (←).

- British and European models

6

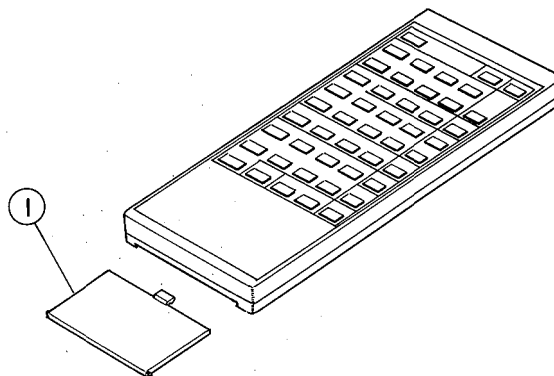

7

Ref. NO.	PART NO.	Description			部 品 名	Remarks	Markets	ランク
	Vi217700	REMOTE CONTROL TRANSMITTER			リモコン		JUCRA	21
01	CX611050	CASE (A) ASS'Y			上ケースASSY			
02	CX611070	CASE (B)			下ケース		UR66CS200E	
03	CX611080	LID			電池蓋		UR66EC201E	
04	CX607950	FILTER, SMOKE			スモーク板		UR66SB257	
05	CX611090	RUBBER, CONTACT (A)			ゴム接点(A)		UR66CT203K	
06	CX611280	RUBBER, CONTACT (B)			ゴム接点(B)		UR66CT203J	
07	CX611290	RUBBER, CONTACT			ゴム接点		UR66CT204J	
08	CX608090	KNOB			ノブ		UR66VTM83	
09	NX605820	P.C.B. ASS'Y			プリント基板ASSY		UR66VPT131	
10	LX602520	TERMINAL, BATTERY			電極板		UR66TD239	
11	E0320066	FLAT HEAD TAPPING SCREW	2x6	FCRM3-BL	皿タッピングネジ	PACK	XTS2+6GFZ	
12	EJ020056	PAN HEAD TAPPING SCREW	2x5	ZMC2-Y	ナベタッピングネジ	PACK	XTB2+5GFZ	
	NX605820	P.C.B. ASS'Y			プリント基板ASSY		UR66VPB131	
	iX612280	PHOTO DIODE	TPS705		フォトダイオード	D1		
	iX614280	LED (RED)	LN01201CQ		LED	D2,3		
	iX612290	LED	SE303AS		赤外線LED	D4,5		
	QX600270	CERAMIC RESONATOR	CSA737MT		セラミック発振子	X1		
	UJ118100	ELECTROLYTIC CAP	100uF	6.3V	ケミコン	C9		
	UJ118220	ELECTROLYTIC CAP	220uF	6.3V	ケミコン	C6		
	LX602530	TERMINAL, BATTERY			電極板	(-)	UR66TD209	
	LX602540	TERMINAL, BATTERY			電極板	(+)	UR66TD208	
01	Vi217800	REMOTE CONTROL TRANSMITTER			リモコン		BG	
	CX607200	LID			電池蓋		PM1-562-11	

*New Parts (新規部品)

ランク : Japan only

• U.S.A., Canadian, Australian and General models

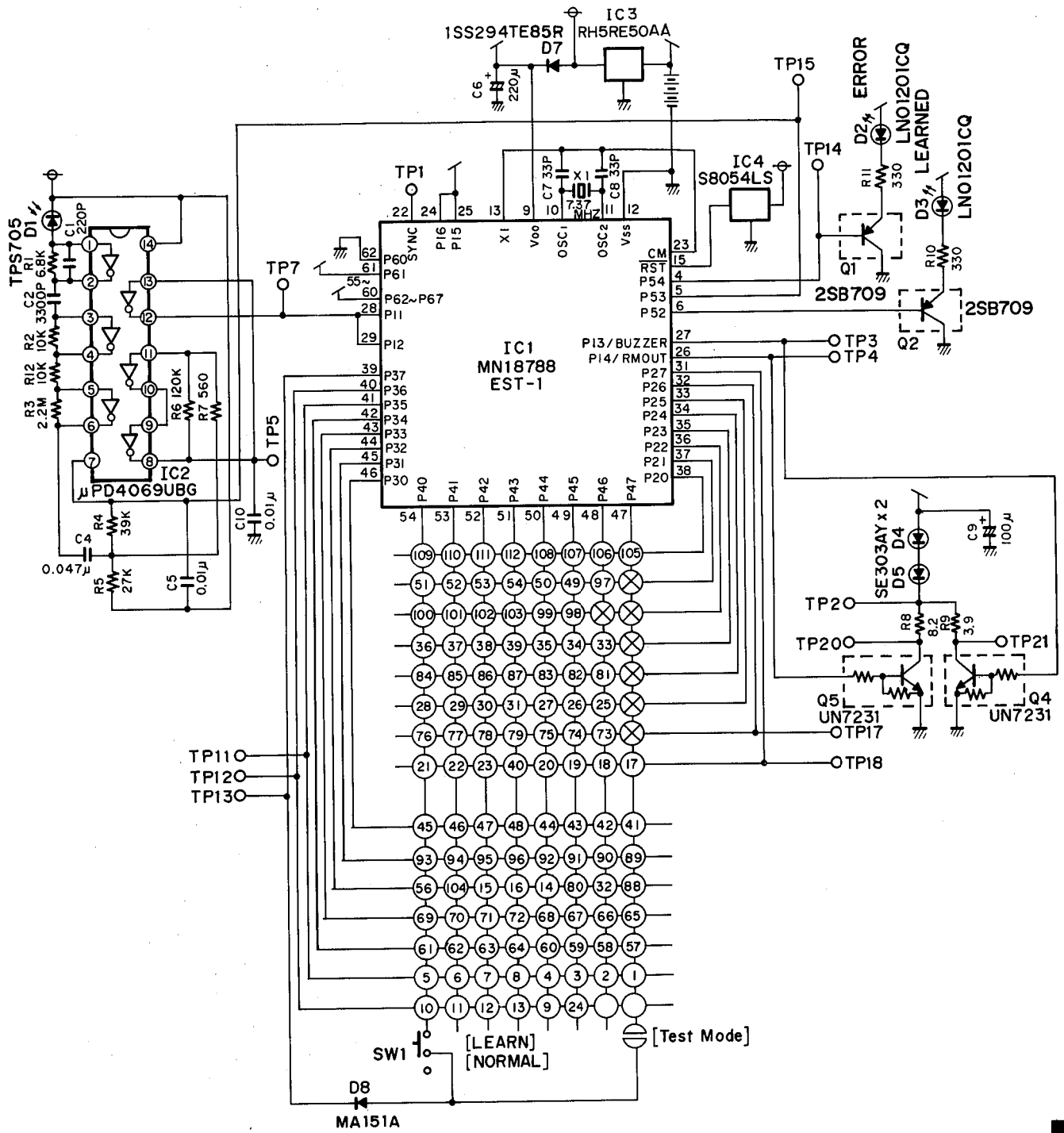

- U.S.A., Canadian, Australian and General models

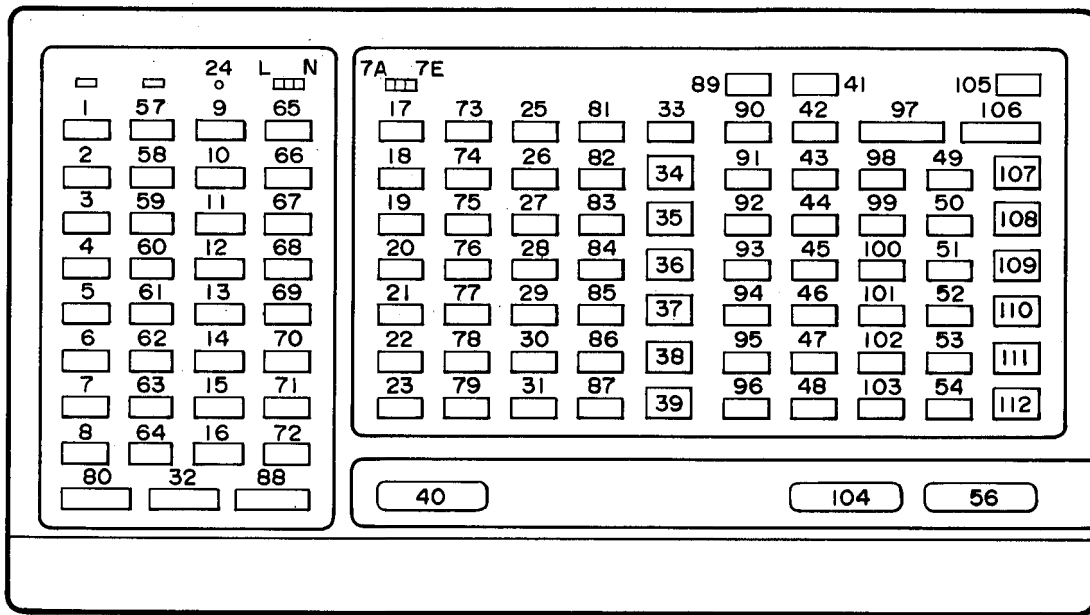

Key No.	FUNCTION	OUTPUT CODE	Key No.	FUNCTION	OUTPUT CODE	Key No.	FUNCTION	OUTPUT CODE
1~16	LEARNING		44	CD SKIP $\triangleright\triangleright$	7E-0A	87	—	—
17, 18	—	—	45	CD SEARCH \triangleright	7E-0C	88	LEARNING	
19	LD OPEN/CLOSE	7C-01	46	TUNER P. DOWEN	7E-11	89	SURROUND MODE DOWN	7E-5A
20	LD CHAPTER "—"	7C-02	47	TAPE DIR A	7E-07	90	CENTER LEVEL DOWN	7E-13
21	LD STILL \triangleleft	7C-0A	48	TAPE $\triangleleft\triangleleft$	7E-01	91	PHONO PLAY/CUT	7E-0E
22	BASS DOWN	7E-54	49	—	—	92	CD SKIP $\triangleleft\triangleleft$	7E-0B
23	MUTING	7E-1C	50	CD DISC UP	7E-4F	93	CD SEARCH $\triangleleft\triangleleft$	7E-0D
24	RESET		51	CD PLAY	7E-08	94	TAPE DECK A/B	7E-06
25, 26	—	—	52	TUNER A/B/C	7E-12	95	TAPE REC/PAUSE	7E-04
27	LD PAUSE/STOP	7C-04	53	TAPE DIR B	7E-40	96	TAPE REC/MUTE	7E-05
28	LD SEARCH $\triangleleft\triangleleft$	7C-06	54	TAPE $\triangleright\triangleright$	7E-02	97	REAR LEVEL DOWN	7E-5F
29	LD SOUND	7C-12	55	—	—	98	—	—
30	TREBLE DOWN	7E-53	56	(VOLUME UP)	(7E-1A)	99	CD DISC DOWEN	7E-50
31	—	—	57~72	LEARNING		100	CD PAUSE/STOP	7E-09
32	LEARNING		73~75	—	—	101	TUNER P. UP	7E-10
33	DELAY TIME UP	7E-5B	76	LD CHAPTER "+"	7C-03	102	TAPE PLAY	7E-00
34	—	—	77	LD STILL \triangleright	7C-0B	103	TAPE STOP	7E-03
35	LD	7E-55	78	BASS UP	7E-1E	104	(VOLUME DOWN)	(7E-1B)
36	—	—	79	—	—	105	SURROUND ON/OFF	7E-58
37	AUX	7E-17	80	LEARNING		106	REAR LEVEL UP	7E-5E
38	VCR 1	7E-56	81	DELAY DOWN	7E-5C	107	PHONO	7E-14
39	VCR 2	7E-57	82	—	—	108	CD	7E-15
40	POWER	7E-1F	83	LD PLAY	7C-05	109	—	—
41	SURROUND MODE UP	7E-59	84	LD SEARCH $\triangleright\triangleright$	7C-07	110	TUNER	7E-16
42	CENTER LEVEL UP	7E-0F	85	LD DISPLAY	7C-13	111	TAPE 1	7E-18
43	—	—	86	TREBLE UP	7E-52	112	TAPE 2 NONI	7E-19

AVX-700

• British and European models

1

2

3

4

5

6

7

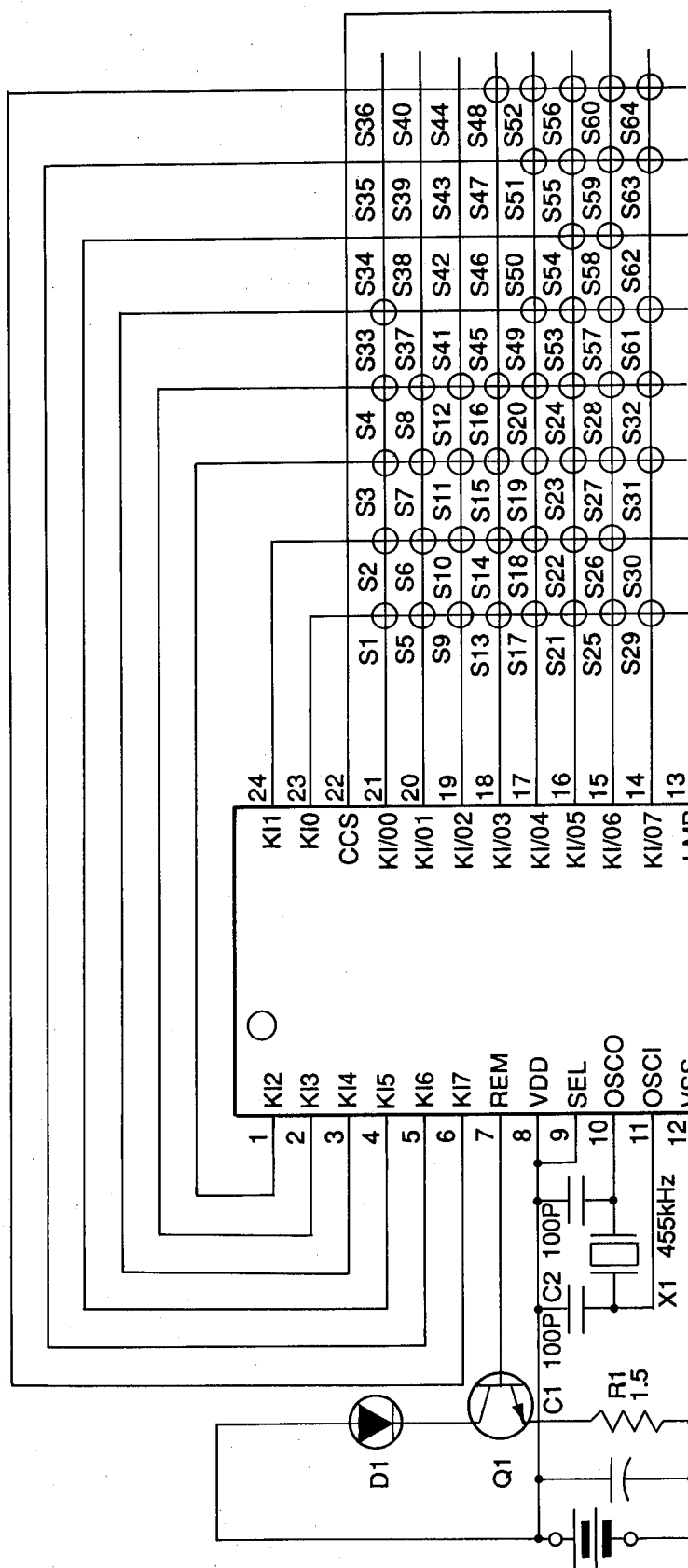

IC1: MPD6122G-510
 D1: SLR-932A
 Q1: 2SC1652R or Q

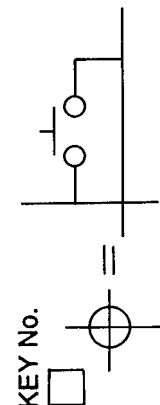

• British and European models

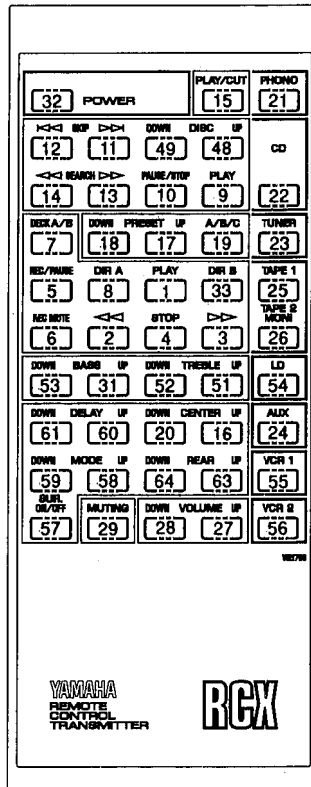

KEY No.	DATA CODE								FUNCTION	KEY No.	DATA CODE								FUNCTION
	D ₀	D ₁	D ₂	D ₃	D ₄	D ₅	D ₆	D ₇			D ₀	D ₁	D ₂	D ₃	D ₄	D ₅	D ₆	D ₇	
1	0	0	0	0	0	0	0	0	PLAY (TAPE)	25	0	0	0	1	1	0	0	0	TAPE 1
2	1	0	0	0	0	0	0	0	⏮ (TAPE)	26	1	0	0	1	1	0	0	0	TAPE 2 MONI
3	0	1	0	0	0	0	0	0	⏭ (TAPE)	27	0	1	0	1	1	0	0	0	VOLUME UP
4	1	1	0	0	0	0	0	0	⏸ (TAPE)	28	1	1	0	1	1	0	0	0	VOLUME DOWN
5	0	0	1	0	0	0	0	0	REC/PAUSE (TAPE)	29	0	0	1	1	1	0	0	0	MUTING
6	1	0	1	0	0	0	0	0	REC MUTE (TAPE)	31	0	1	1	1	1	0	0	0	BASS UP
7	0	1	1	0	0	0	0	0	DECK A/B (TAPE)	32	1	1	1	1	1	0	0	0	POWER
8	1	1	1	0	0	0	0	0	DIR A (TAPE)	33	0	0	0	0	0	0	1	0	DIR B (TAPE)
9	0	0	0	1	0	0	0	0	PLAY (CD)	48	1	1	1	1	0	0	1	0	DISC UP (CD)
10	1	0	0	1	0	0	0	0	PAUSE/STOP (CD)	49	0	0	0	0	1	0	1	0	DISC DOWN (CD)
11	0	1	0	1	0	0	0	0	SKIP ⏭ (CD)	51	0	1	0	0	1	0	1	0	TREBLE UP
12	1	1	0	1	0	0	0	0	SKIP ⏮ (CD)	52	1	1	0	0	1	0	1	0	TREBLE DOWN
13	0	0	1	1	0	0	0	0	SEARCH ⏭ (CD)	53	0	0	1	0	1	0	1	0	BASS DOWN
14	1	0	1	1	0	0	0	0	SEARCH ⏮ (CD)	54	1	0	1	0	1	0	1	0	LD
15	0	1	1	1	0	0	0	0	PLAY/CUT (PHONO)	55	0	1	1	0	1	0	1	0	VCR 1
16	1	1	1	1	0	0	0	0	CENTER UP	56	1	1	1	0	1	0	1	0	VCR 2
17	0	0	0	0	1	0	0	0	PRESET UP (TUNER)	57	0	0	0	1	1	0	1	0	SUR. ON/OFF
18	1	0	0	0	1	0	0	0	PRESET DOWN (TUNER)	58	1	0	0	1	1	0	1	0	MODE UP
19	0	1	0	0	1	0	0	0	A/B/C (TUNER)	59	0	1	0	1	1	0	1	0	MODE DOWN
20	1	1	0	0	1	0	0	0	CENTER DOWN	60	1	1	0	1	1	0	1	0	DELAY UP
21	0	0	1	0	1	0	0	0	PHONO	61	0	0	1	1	1	0	1	0	DELAY DOWN
22	1	0	1	0	1	0	0	0	CD	63	0	1	1	1	1	0	1	0	REAR UP
23	0	1	1	0	1	0	0	0	TUNER	64	1	1	1	1	1	0	1	0	REAR DOWN
24	1	1	1	0	1	0	0	0	AUX										

AVX-700

Parts List for Carbon Resistors

Value	1/4W Type Part No.	1/6W Type Part No.	Value	1/4W Type Part No.	1/6W Type Part No.
1.0Ω	HJ35 3100	※	12KΩ	HJ35 7120	HF85 7120
1.8 "	HJ35 3180	※	15 "	HJ35 7150	HF85 7150
2.2 "	HJ35 3220	HF85 3220	18 "	HJ35 7180	HF85 7180
3.3 "	HJ35 3330	HF85 3330	22 "	HJ35 7220	HF85 7220
4.7 "	HJ35 3470	HF85 3470	27 "	HJ35 7270	HF85 7270
5.6 "	HJ35 3560	HF85 3560	33 "	HJ35 7330	HF85 7330
10 "	HJ35 4100	HF85 4100	39 "	HJ35 7390	HF85 7390
15 "	HJ35 4150	HF85 4150	47 "	HJ35 7470	HF85 7470
22 "	HJ35 4220	HF85 4220	56 "	HJ35 7560	HF85 7560
27 "	HJ35 4270	HF85 4270	68 "	HJ35 7680	HF85 7680
33 "	HJ35 4330	HF85 4330	82 "	HJ35 7820	HF85 7820
39 "	HJ35 4390	HF85 4390	91 "	HJ35 7910	HF85 7910
47 "	HJ35 4470	HF85 4470	100 "	HJ35 8100	HF85 8100
56 "	HJ35 4560	HF85 4560	120 "	HJ35 8120	HF85 8120
68 "	HJ35 4680	HF85 4680	150 "	HJ35 8150	HF85 8150
82 "	HJ35 4820	HF85 4820	180 "	HJ35 8180	HF85 8180
100 "	HJ35 5100	HF85 5100	220 "	HJ35 8220	HF85 8220
110 "	HJ35 5110	HF85 5100	270 "	HJ35 8270	HF85 8270
120 "	HJ35 5120	HF85 5120	330 "	HJ35 8330	HF85 8330
150 "	HJ35 5150	HF85 5150	390 "	HJ35 8390	HF85 8390
160 "	HJ35 5160	※	470 "	HJ35 8470	HF85 8470
180 "	HJ35 5180	HF85 5180	560 "	HJ35 8560	HF85 8560
220 "	HJ35 5220	HF85 5220	680 "	HJ35 8680	HF85 8680
270 "	HJ35 5270	HF85 5270	820 "	HJ35 8820	HF85 8820
330 "	HJ35 5330	HF85 5330	1.0MΩ	HJ35 9100	HF85 9100
390 "	HJ35 5390	HF85 5390	1.2 "	HJ35 9120	※
470 "	HJ35 5470	HF85 5470	1.5 "	HJ35 9150	HF85 9150
510 "	※	HF85 5510	1.8 "	HJ35 9180	HF85 9180
560 "	HJ35 5560	HF85 5560	2.2 "	HJ35 9220	HF85 9220
680 "	HJ35 5680	HF85 5680	3.3 "	HJ35 9330	HF85 9330
820 "	HJ35 5820	HF85 5820	3.9 "	HJ35 9390	※
910 "	HJ35 5910	HF85 5910	4.7 "	HJ35 9470	※
1.0KΩ	HJ35 6100	HF85 6100			
1.2 "	HJ35 6120	HF85 6120			
1.5 "	HJ35 6150	HF85 6150			
1.8 "	HJ35 6180	HF85 6180			
2.0 "	HJ35 6200	HF85 6200			
2.2 "	HJ35 6220	HF85 6220			
2.4 "	HJ35 6240	HF85 6240			
2.7 "	HJ35 6270	HF85 6270			
3.0 "	HJ35 6300	HF85 6300			
3.3 "	HJ35 6330	HF85 6330			
3.6 "	HJ35 6360	HF85 6360			
3.9 "	HJ35 6390	HF85 6390			
4.7 "	HJ35 6470	HF85 6470			
5.1 "	HJ35 6510	HF85 6510			
5.6 "	HJ35 6560	HF85 6560			
6.8 "	HJ35 6680	HF85 6680			
8.2 "	HJ35 6820	HF85 6820			
9.1 "	HJ35 6910	HF85 6910			
10 "	HJ35 7100	HF85 7100			

1/4W Type

HJ35 ○○○○

10mm

1/6W Type

HF85 ○○○○

5mm

AVX-700

YAMAHA