

STEREO INTEGRATED AMPLIFIER AX-530

SERVICE MANUAL

IMPORTANT NOTICE

This manual has been provided for the use of authorized Yamaha Retailers and their service personnel. It has been assumed that basic service procedures inherent to the industry, and more specifically Yamaha Products, are already known and understood by the users, and have therefore not been restated.

WARNING: Failure to follow appropriate service and safety procedures when servicing this product may result in personal injury, destruction of expensive components and failure of the product to perform as specified. For these reasons, we advise all Yamaha product owners that all service required should be performed by an authorized Yamaha Retailer or the appointed service representative.

IMPORTANT: The presentation or sale of this manual to any individual or firm does not constitute authorization, certification or recognition of any applicable technical capabilities, or establish a principle-agent relationship of any form.

The data provided is believed to be accurate and applicable to the unit(s) indicated on the cover. The research, engineering, and service departments of Yamaha are continually striving to improve Yamaha products. Modifications are, therefore, inevitable and specifications are subject to change without notice or obligation to retrofit. Should any discrepancy appear to exist, please contact the distributor's Service Division.

WARNING: Static discharges can destroy expensive components. Discharge any static electricity your body may have accumulated by grounding yourself to the ground buss in the unit (heavy gauge black wires connect to this buss).

IMPORTANT: Turn the unit OFF during disassembly and parts replacement. Recheck all work before you apply power to the unit.

■ CONTENTS

TO SERVICE PERSONNEL.....	1	ADJUSTMENTS	5
FRONT PANEL.....	1	IC BLOCK	6,7
REAR PANELS.....	1	PRINTED CIRCUIT BOARD	8-13
INTERNAL VIEW	2	WIRING	13
SPECIFICATIONS.....	3	SCHEMATIC DIAGRAM	14
BLOCK DIAGRAM	4	PARTS LIST	15-22
DISASSEMBLY PROCEDLRES	5		

TO SERVICE PERSONNEL

- Critical Components Information.**
Components having special characteristics are marked Δ and must be replaced with parts having specifications equal to those originally installed.
- Leakage Current Measurement (For 120V Model Only).**
When service has been completed, it is imperative that you verify that all exposed conductive surfaces are properly insulated from supply circuits.
 - Meter impedance should be equivalent to 1500 ohm shunted by 0.15 μ F.
 - Leakage current must not exceed 0.5mA.
 - Be sure to test for leakage with the AC plug in both polarities.

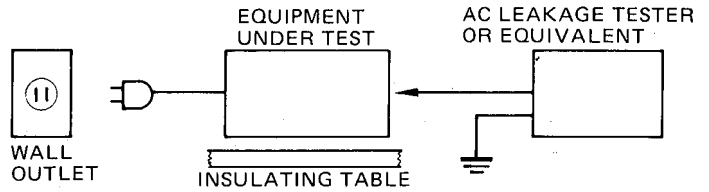

FRONT PANEL

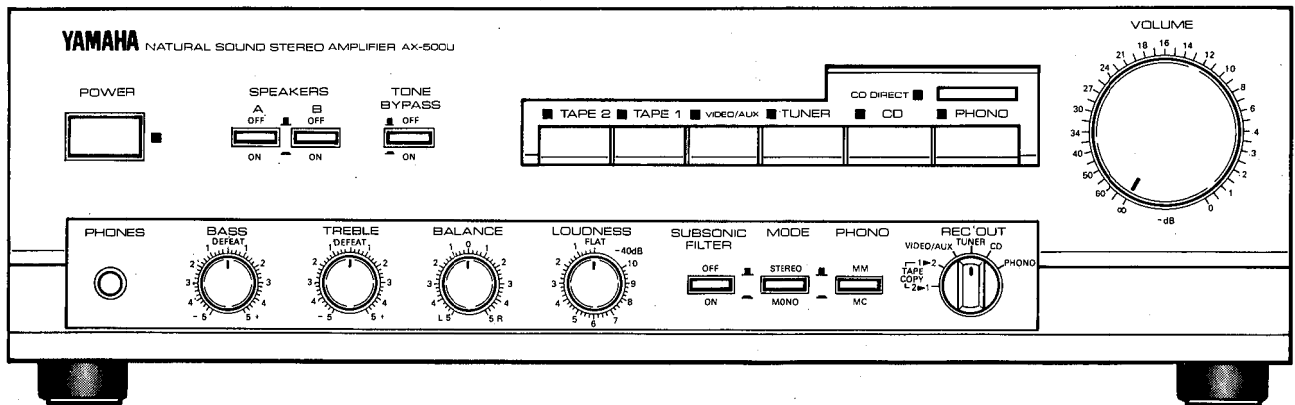

REAR PANELS

▼ Australian & British models

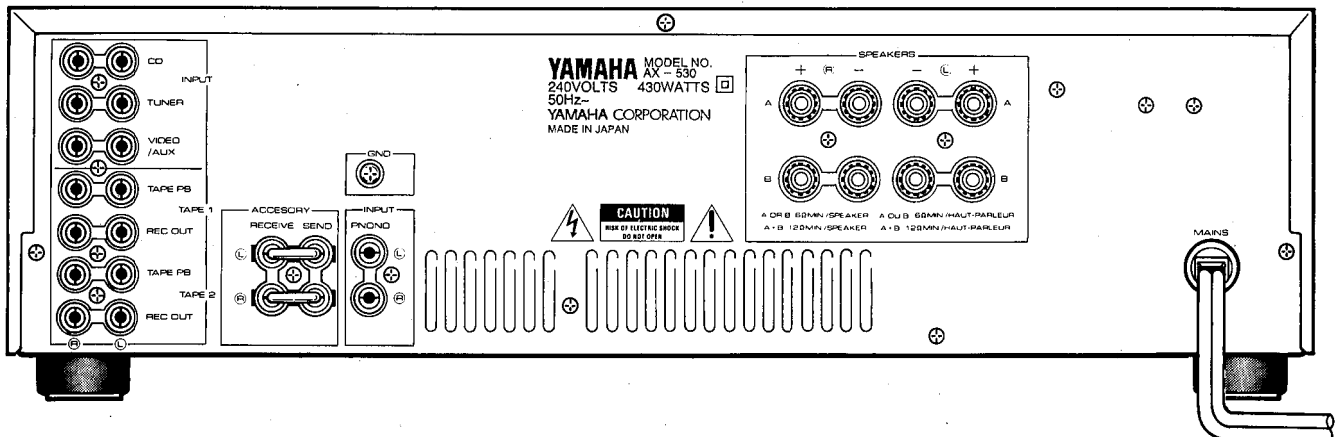

▼ European model

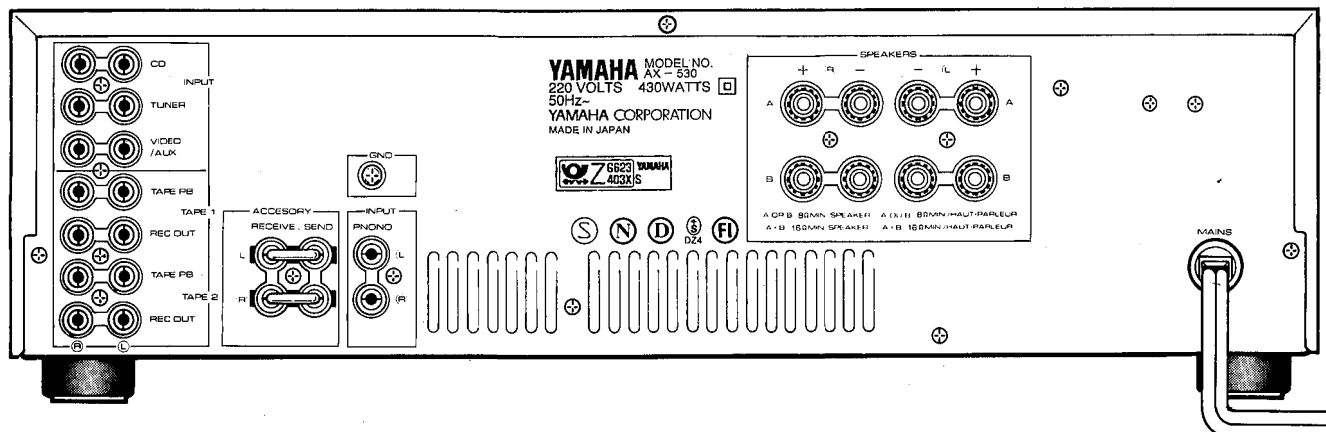

▼ General model

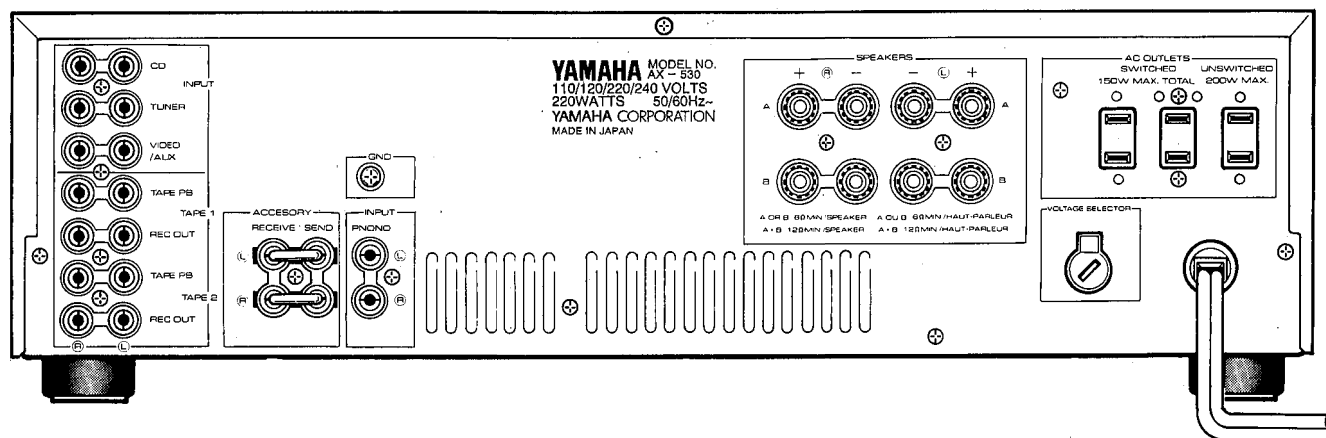

■ INTERNAL VIEW

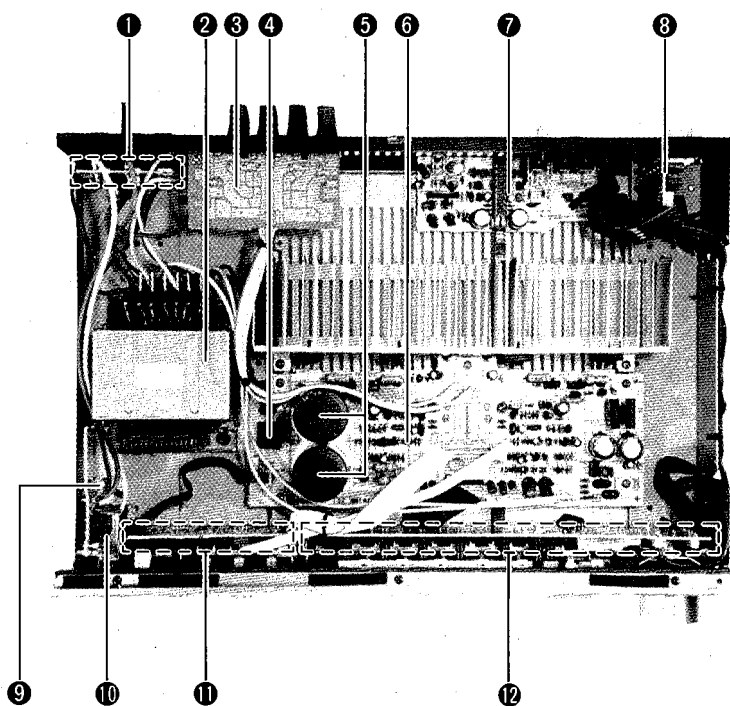

- ① SUB CIRCUIT BOARD(3)
- ② POWER TRANSFORMER
A,B models : XG096A00
G model : XG097A00
R model : XG095A00
- ③ SUB CIRCUIT BOARD(1)
- ④ BRIDGE DIODE : iH001160(4D4B41)
- ⑤ ELECTROLITIC CAP
12000 μ F 71V : VE442800
- ⑥ MAIN CIRCUIT BOARD(1)
- ⑦ MAIN CIRCUIT BOARD(3)
- ⑧ MAIN CIRCUIT BOARD(4)
- ⑨ FUSE
A,B,G models : KB002980(T2.5A 250V)
R model : KB001300(7.0A 250V)
- ⑩ POWER SWITCH
- ⑪ MAIN CIRCUIT BOARD(5)
- ⑫ MAIN CIRCUIT BOARD(2)

SPECIFICATIONS

Minimum RMS Output Power Per Channel
 20Hz ~ 20kHz 0.01% THD 8Ω 85W
 0.015% THD 6Ω (General models) 100W

Dynamic Power Per Channel
 (by IHF Dynamic Headroom Measuring Method)
 8Ω/6Ω/4Ω/2Ω
 General models 160W/200W/230W/250W
 European, British and Australian models 140W/170W/200W/220W

DIN Standard Output Power Per Channel (European model)
 1kHz 1% THD 4Ω 110W

Dynamic Headroom
 8Ω 2.75dB
 6Ω 3.01dB

IEC Power (European model)
 1kHz 0.01% THD 8Ω 100W

Power Bandwidth
 0.03% THD 42.5W 8Ω 10Hz ~ 50kHz

Damping Factor
 1kHz 8Ω ≥ 80

Input Sensitivity/Impedance
 Phono MC 160μV/220Ω
 MM 2.5mV/47kΩ
 CD/TUNER/VIDEO-AUX/TAPE 150mV/47kΩ

Input Sensitivity (New IHF) (General model)
 Phono MC 19μV
 MM 0.27mV
 CD/VIDEO-AUX/TUNER/TAPE 15.5mV

Maximum Input Signal 1kHz
 0.01% THD Phono MC 10mV
 MM 150mV

Output Level/Impedance
 REC OUT 150mV/220Ω

Headphone Jack Rated Output/Impedance
 0.01% THD RL = 8Ω 0.5V/120Ω

Frequency Response
 CD/TUNER/VIDEO-AUX/TAPE 20Hz ~ 20kHz, ± 0.5dB

RIAA Equalization Deviation
 Phono MC ± 0.5dB
 MM 20Hz ~ 20kHz, ± 0.3dB

Total Harmonic Distortion 20Hz ~ 20kHz
 Phono MC to REC OUT, 3V 0.007%
 MM to REC OUT, 3V 0.003%

Intermodulation Distortion
 CD/TUNER/VIDEO-AUX/TAPE Rated Output/8Ω 0.01%

Signal to Noise Ratio (IHF-A-Network)

Phono MC (500μV Input Shorted) 76dB
 MM (5mV Input Shorted) 92dB
 CD/TUNER/VIDEO-AUX/TAPE (Shorted) 102dB

Channel Separation Vol (New IHF)
 Phono MC 75dB
 MM 75dB
 CD/VIDEO-AUX/TUNER/TAPE 85dB

Residual Noise (IHF-A-Network)
 Channel Separation Vol - 30dB
 Phono MC, MM Input shorted 1kHz/10kHz 75dB/60dB
 CD/TUNER/VIDEO-AUX/TAPE Input 5.1kΩ terminated 1kHz/10kHz 75dB/60dB

Tone Control Characteristics
 Bass boost/cut ± 10dB (20Hz) turnover frequency 350Hz
 Treble boost/cut ± 10dB (20kHz) turnover frequency 3.5kHz

Filter Characteristics
 Subsonic 15Hz - 12dB/oct

Continuous Loudness Control (Level Related Equalization)
 Attenuation - 40dB (1kHz)

Gain Tracking Error
 (0 ~ - 60dB) 2dB

Power Supply
 British and Australian models AC 240V 50Hz
 European model AC 220V 50Hz
 General model AC 110/120/220/240V 60/50Hz

Power Consumption
 British and Australian models 430W
 European model 430W
 General model 220W

AC Outlets (General models)
 Switched x 2 150W max.
 Unswitched x 1 200W max.

Dimensions (W x H x D) 435 x 141 x 332mm (17.1 x 5.5 x 13.1 in)

Weight 7.8kg (17lbs. 3oz.)

* Specifications subject to change without notice.

● Dimensions

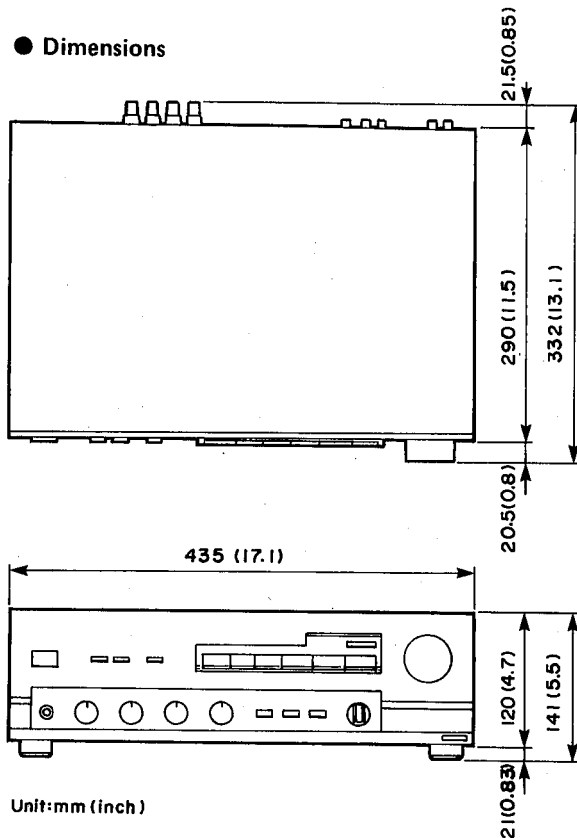

Unit:mm (inch)

- (A) Australian model
- (G) European model
- (B) British model
- (R) General model

■ BLOCK DIAGRAM

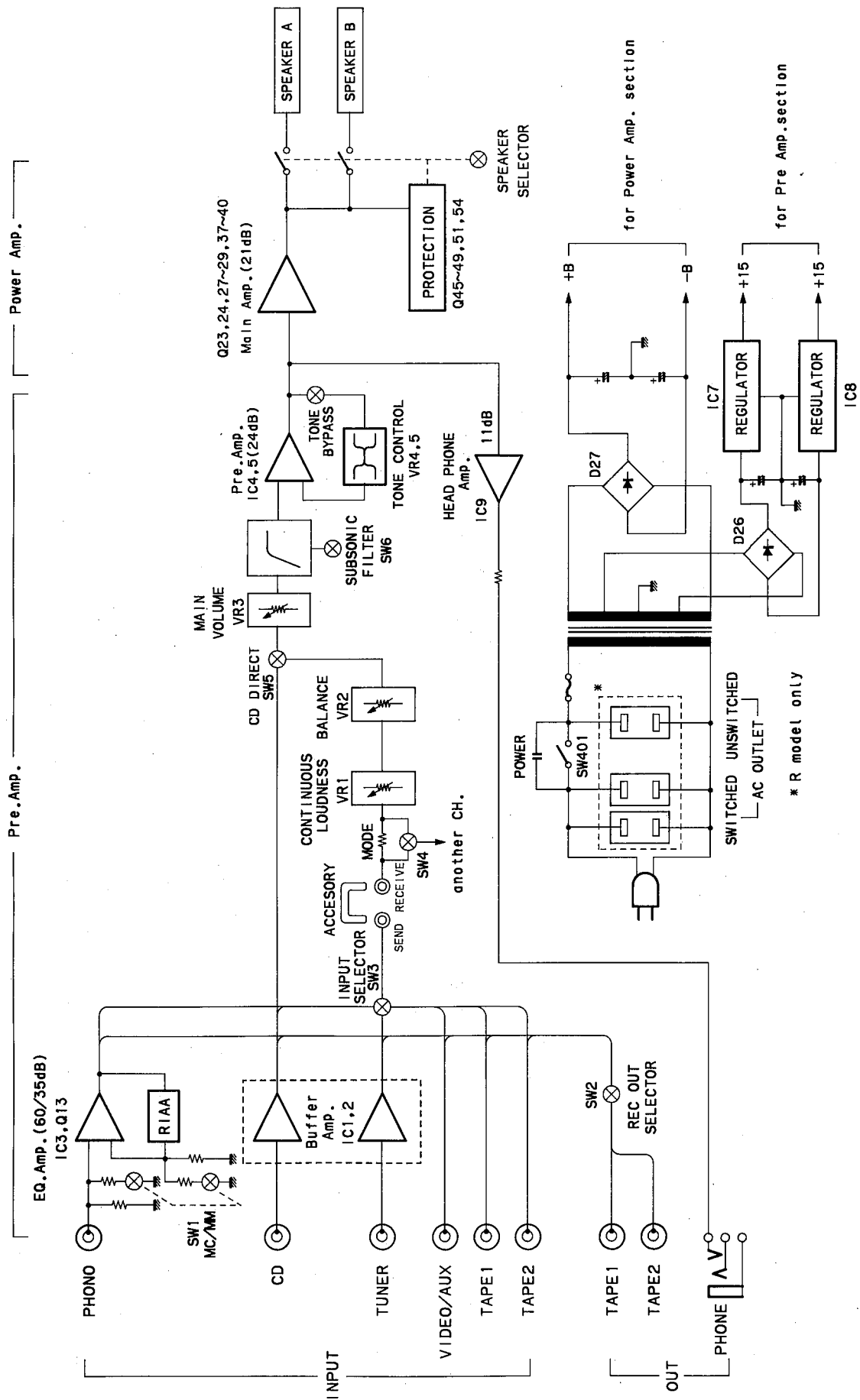

DISASSEMBLY PROCEDURES

(Removal parts in disassembly order as numbered.)

1. Removal of top cover

Remove 5 screws (①).

2. Removal of bottom cover

Remove 7 screws (②).

3. Removal of front panel

Remove 6 screws (③), and pull the front panel forward.

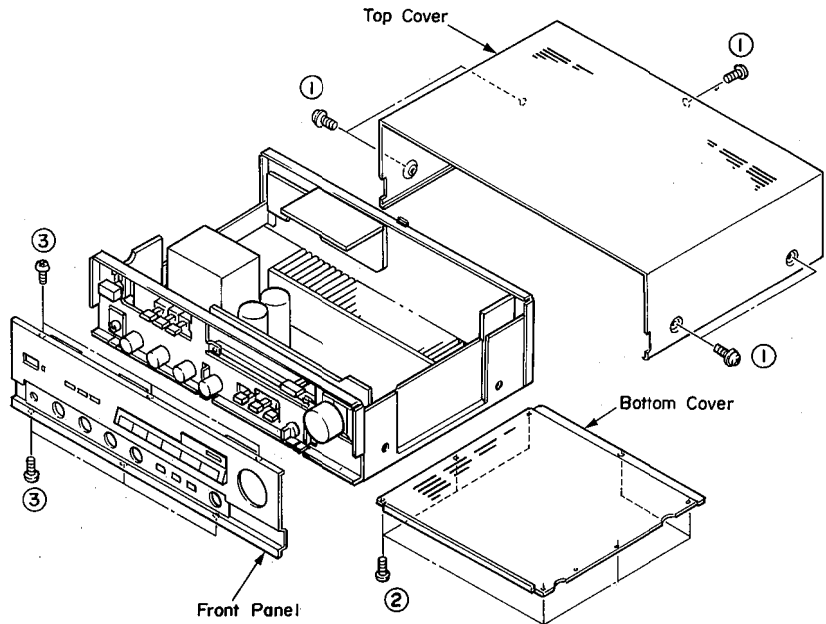

ADJUSTMENTS

● IDLING CURRENT ADJUSTMENT

When replacing the power and drive transistors, adjust idling current in no signal and non load condition.

Adjust VR7(Lch) and VR8(Rch) so that the voltage across the terminal of R188 or R191 and R203 or R205 come to $5\text{mV} \pm 1\text{mV DC}$.

	Test points	Adjustment points	Test points
Lch	R188 or R191	VR7	$5\text{mV} \pm 1\text{mV DC}$.
Rch	R203 or R205	VR8	$5\text{mV} \pm 1\text{mV DC}$.

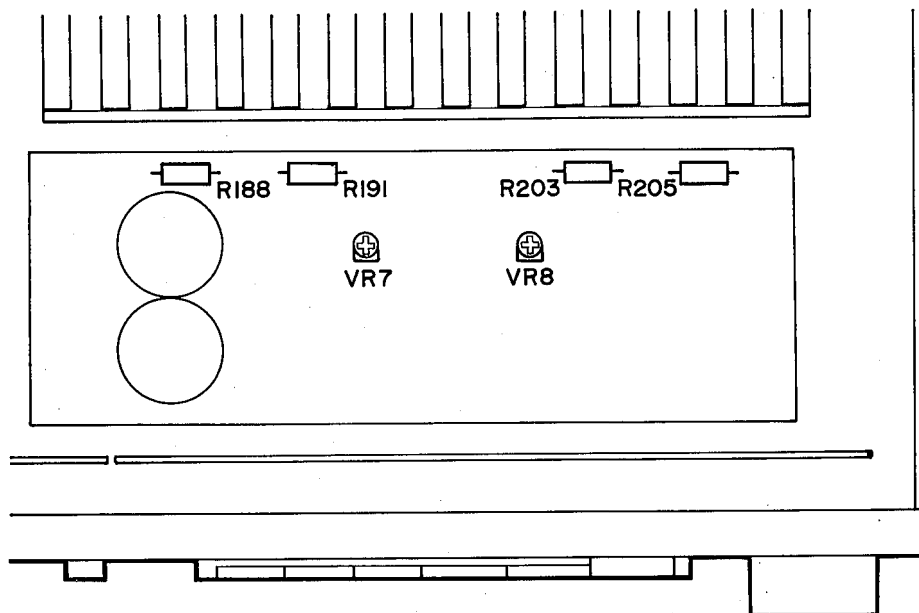

■ IC BLOCK

IC1,2,5 : μ PC4570G2-T1
(Dual Ope-Amp.)

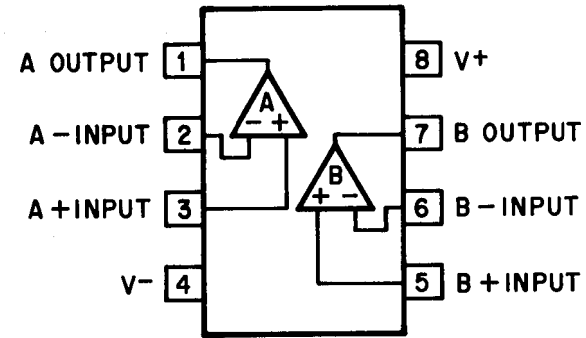

IC3 : μ PC4570HA
IC4 : NJM5532SD
IC9 : NJM4556S-A
(Ope-Amp.)

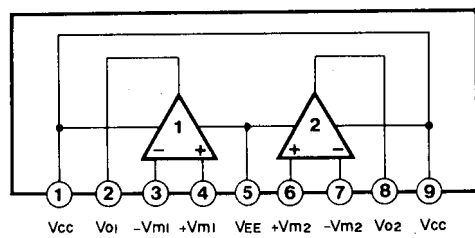

IC7 : NJM78M15FA
(Regulator)

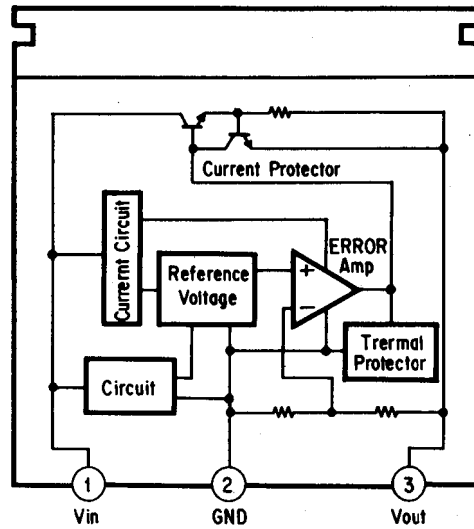

IC8 : NJM79M15FA
(Regulator)

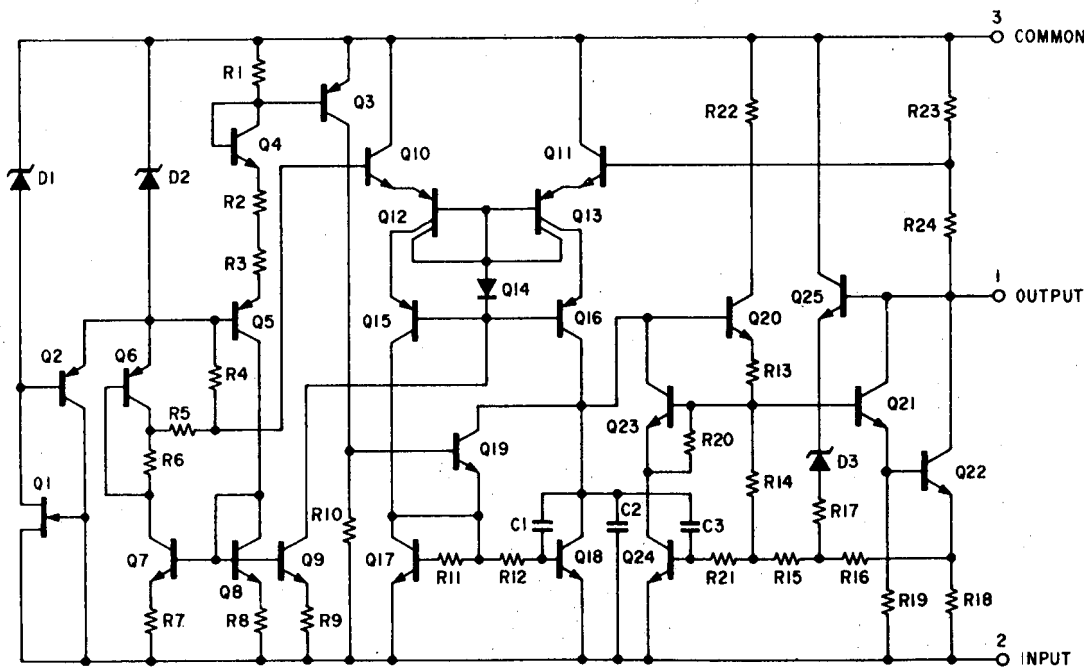

■ WIRING

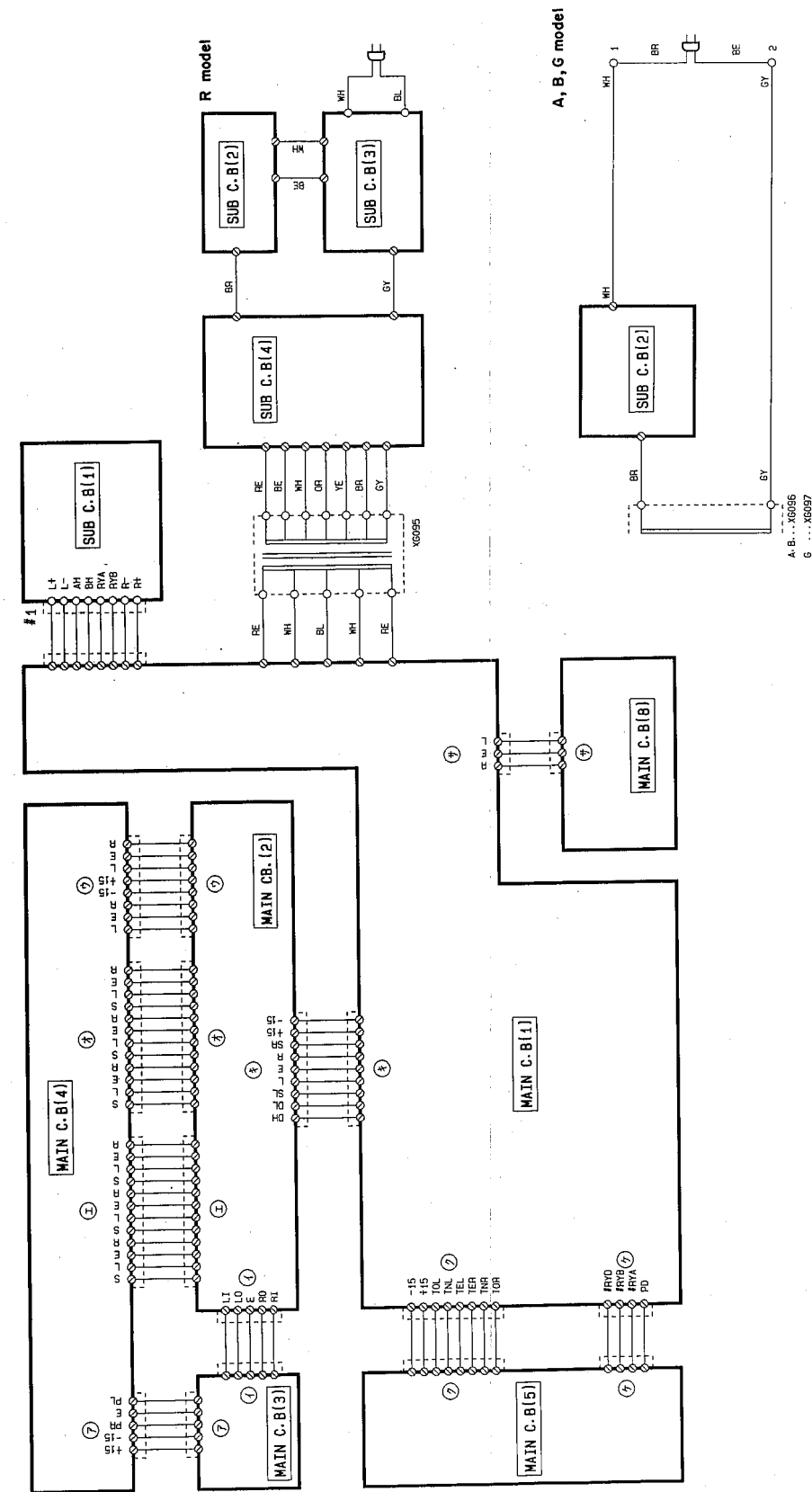

PRINTED CIRCUIT BOARD(Pattern side) Notes) 文字面 :Component side

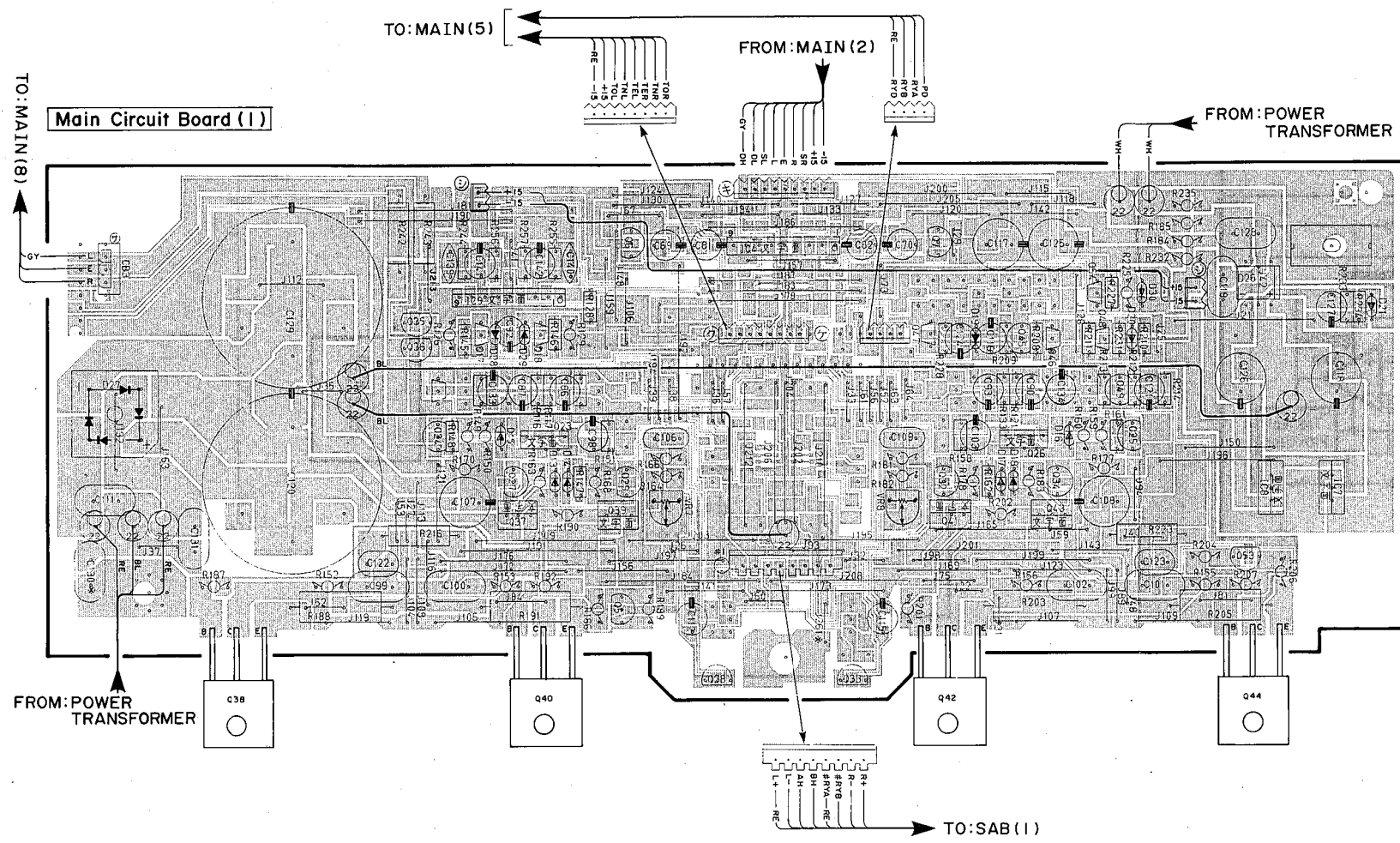

Main Circuit Board (1) (Chip Side)

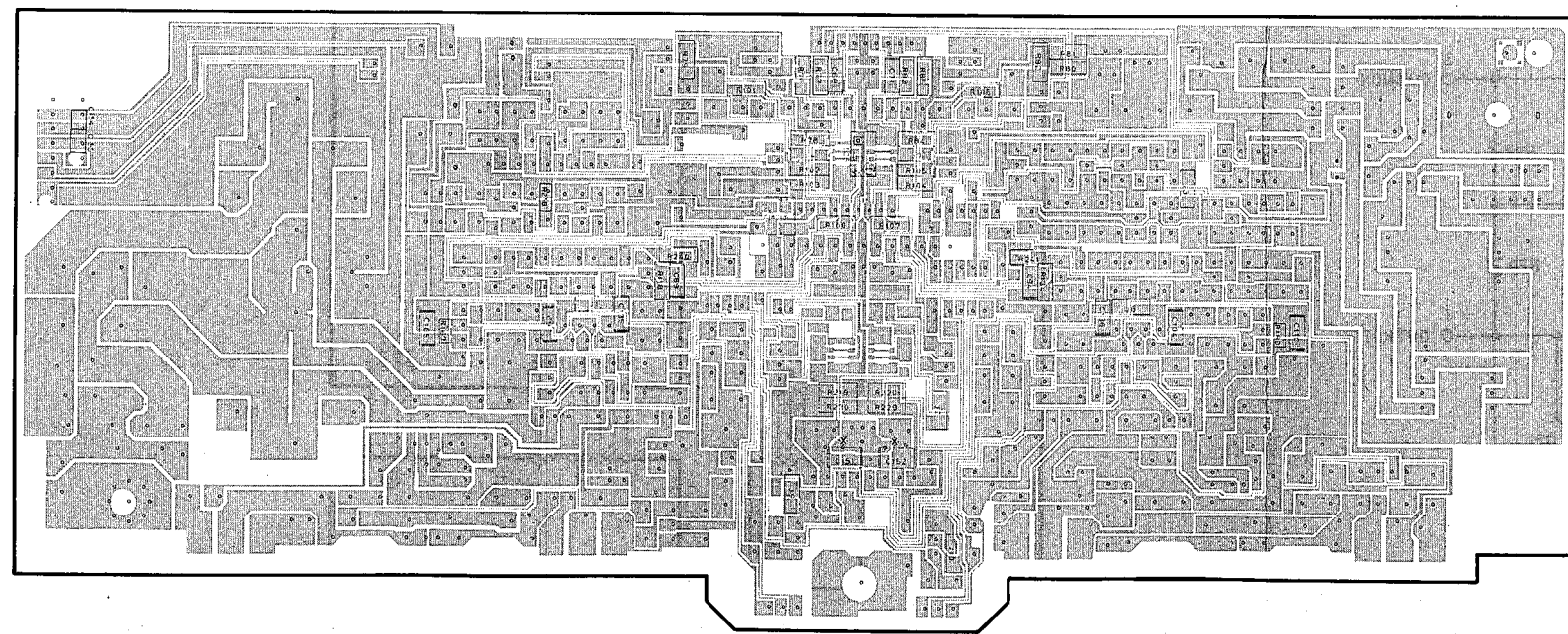

Main Circuit Board (3)

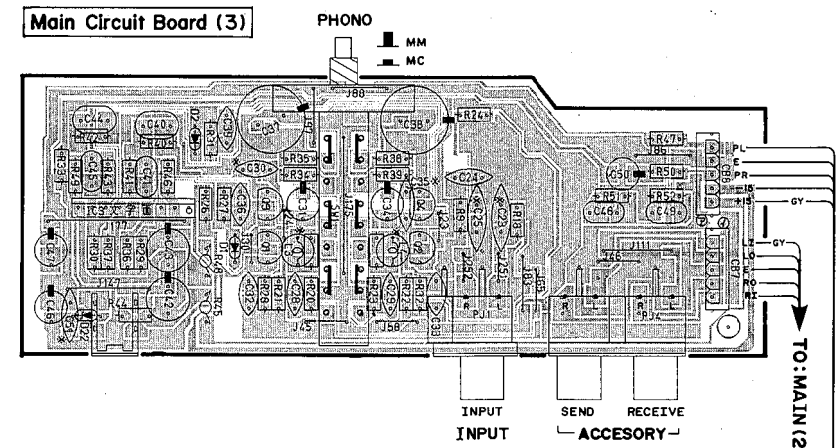

Main Circuit Board (4)

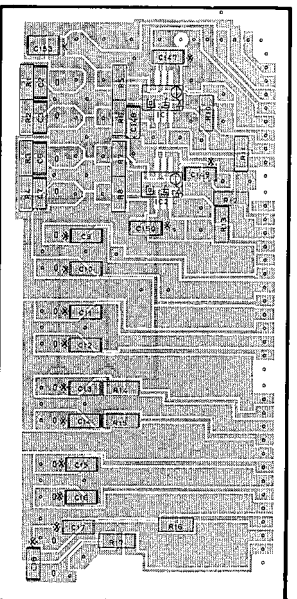
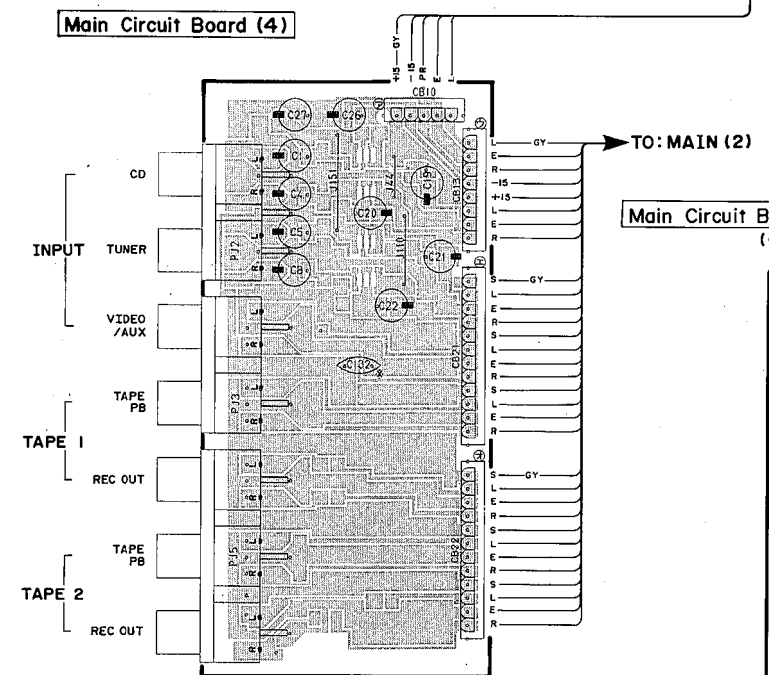

Notes) ※ marked

	R	A,B	G
C9~18	OPEN	OPEN	470P
C23,25	OPEN	OPEN	220P
C30,35	OPEN	OPEN	100P
C51	OPEN	OPEN	5600P
C130	OPEN	OPEN	0.01/100
C132	OPEN	OPEN	0.01
C145,146	OPEN	OPEN	0.047
C147~150	OPEN	OPEN	47P
C151~153	OPEN	OPEN	0.1
L3,4	OPEN	OPEN	220 μH
J261	OPEN	OPEN	SHORT
C401,403,404,406	OPEN	OPEN	0.01
C402,405	OPEN	OPEN	0.022
C408,409	OPEN	OPEN	0.047
F402	3.5A 250V	OPEN	OPEN
J431,432	SHORT	OPEN	OPEN
R405,406	OPEN	OPEN	2.2

1
2
3
4
5
6

PRINTED CIRCUIT BOARD(Pattern side)

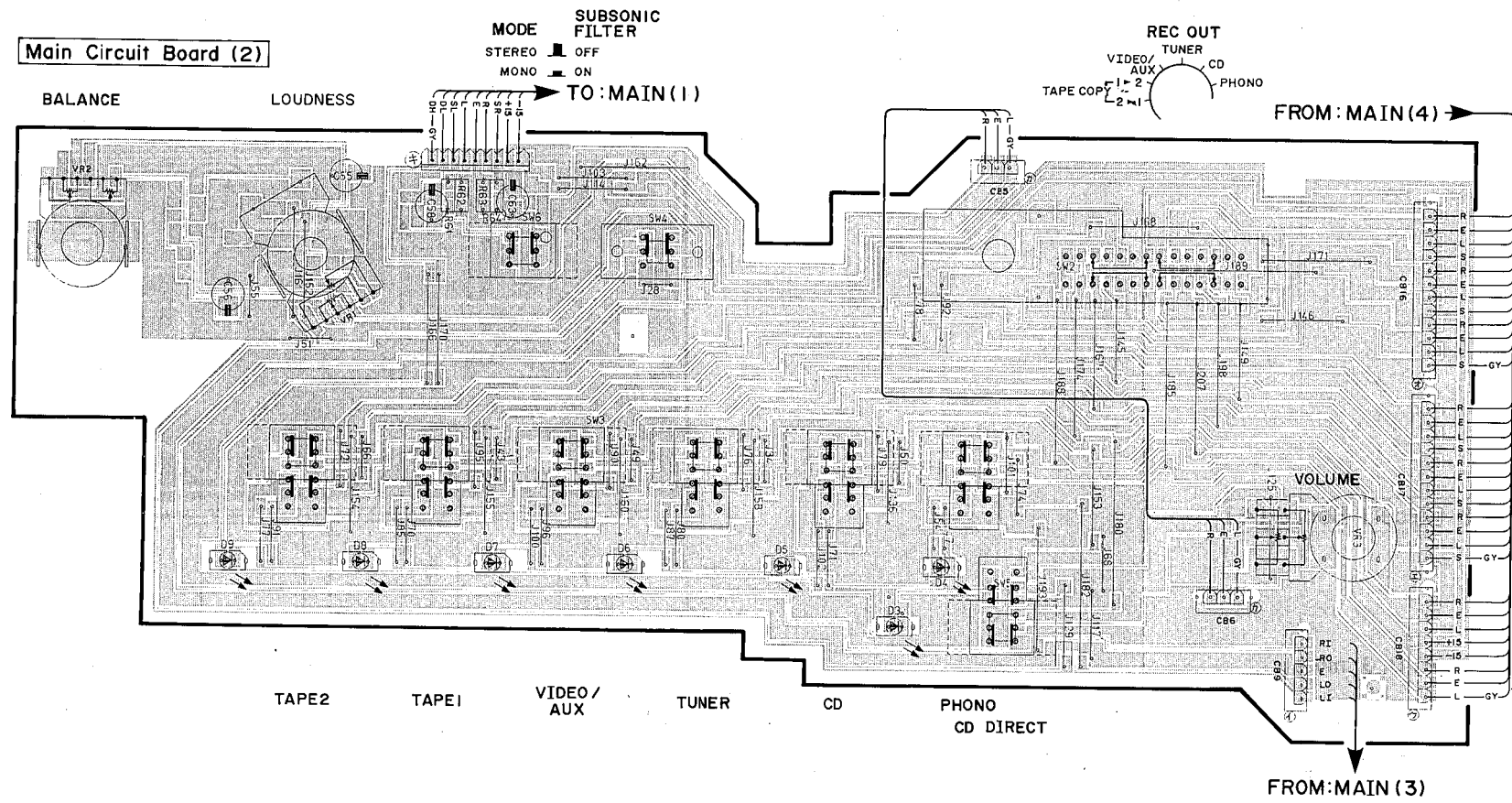

Main Circuit Board (2) (Chip Side)

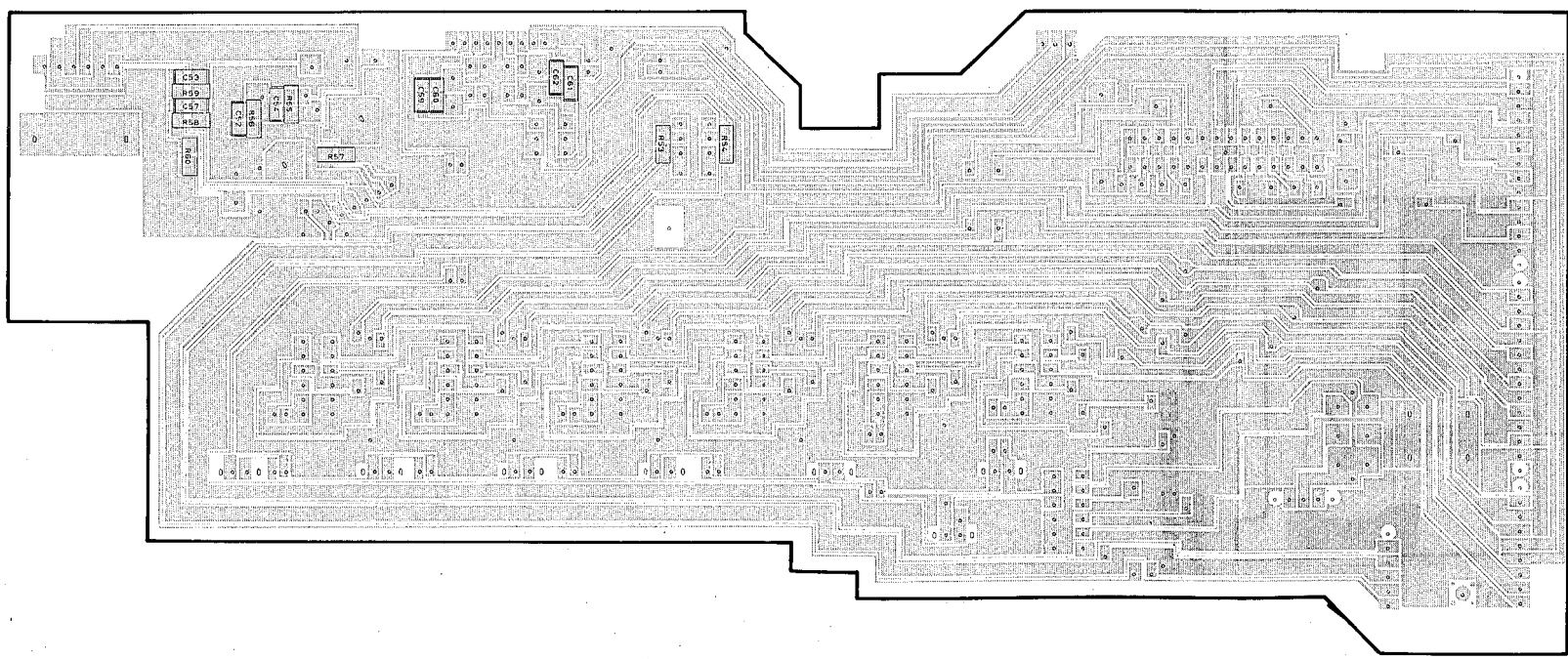

Main Circuit Board (5)

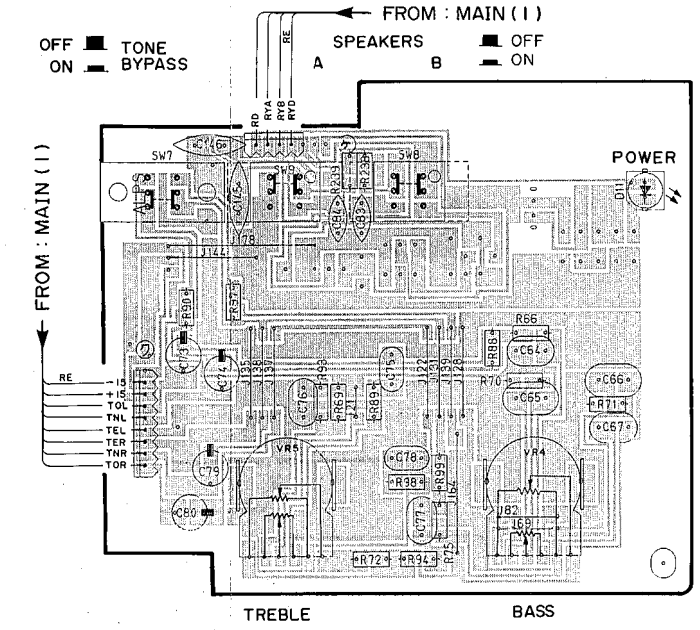

Main Circuit Board (5) (Chip side)

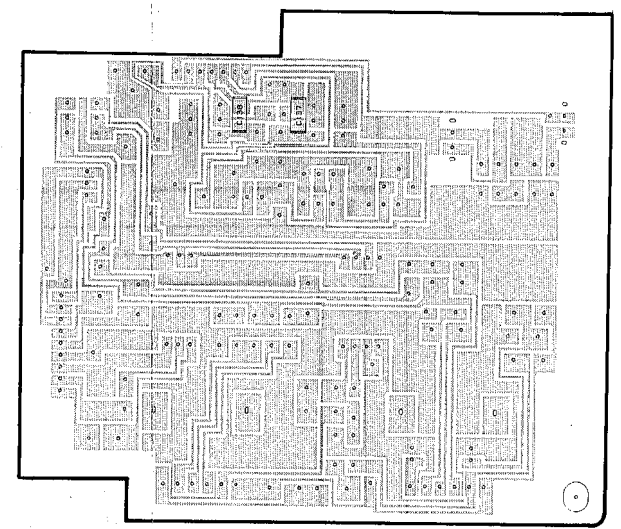

Main Circuit Board (8)

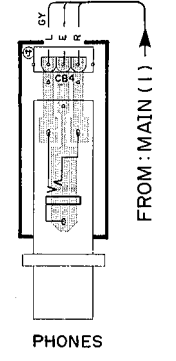

1
2
3
4
5
6

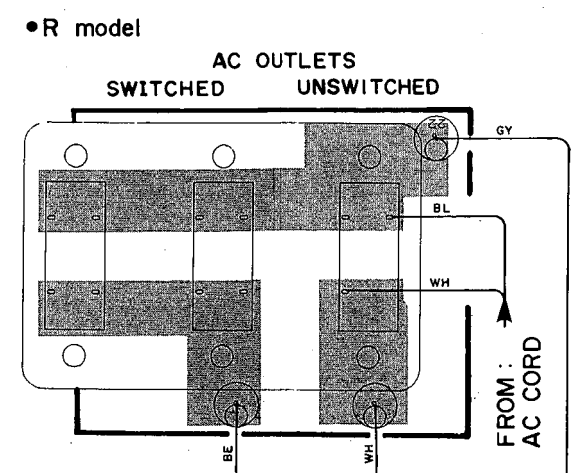

Sub Circuit Board (3)

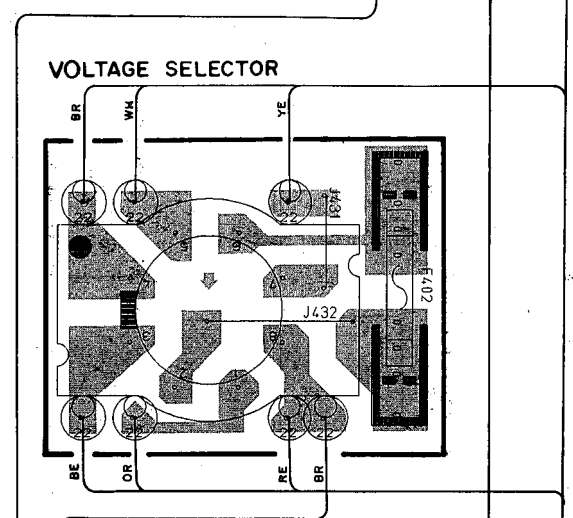

Sub Circuit Board (4)

• A, B, G models

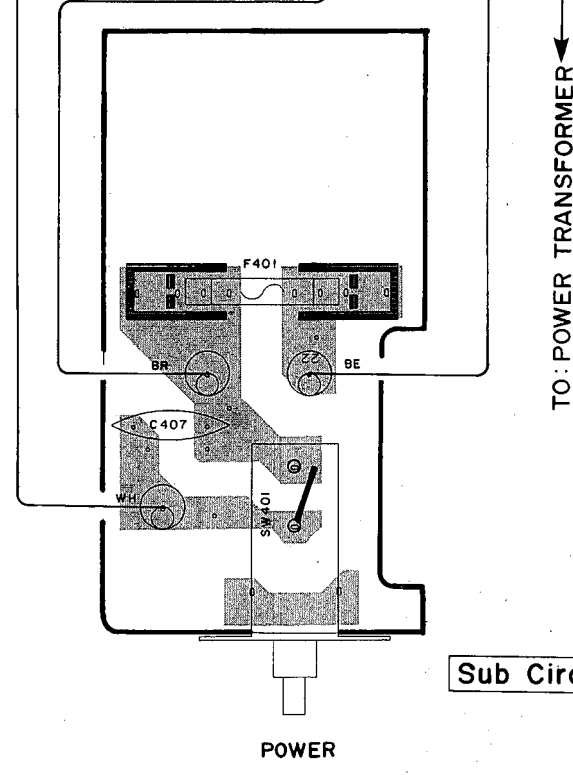
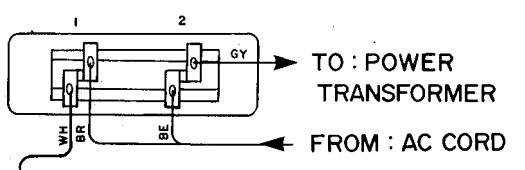

Sub Circuit Board (2)

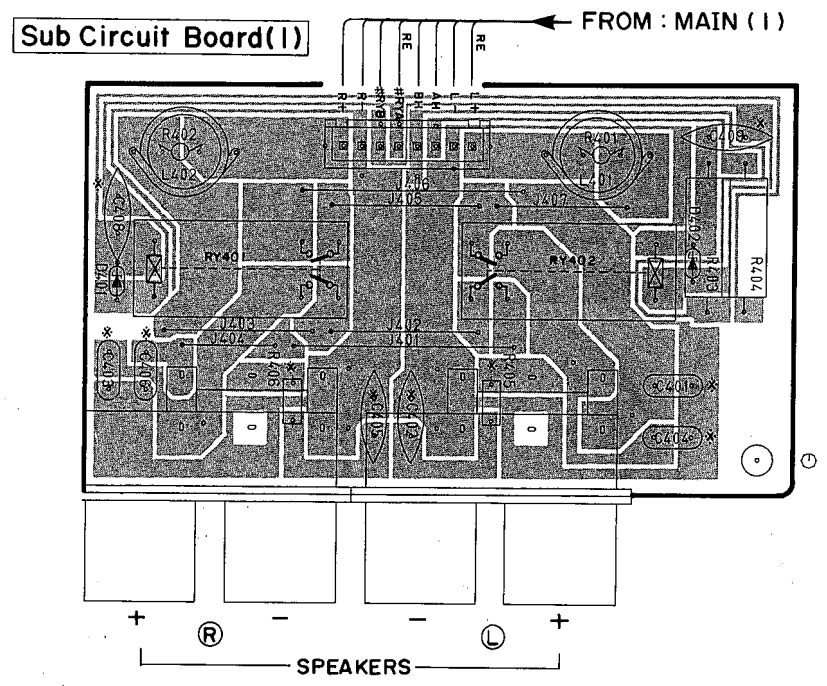
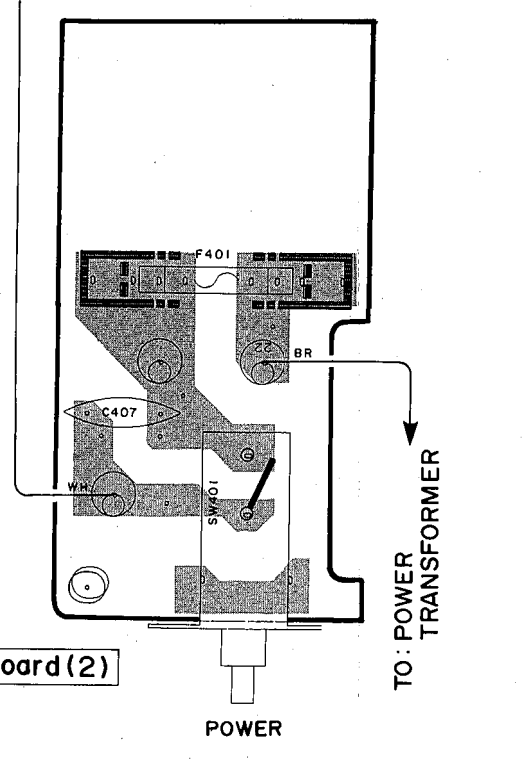

SCHEMATIC DIAGRAM

Q	A	B	C	D	E	F	G
*1	C51	OPEN	5600P				
*2	C132	OPEN	0.01				
*3	C23	OPEN	220P				
*4	R48	3A	2.2				
*5	R27	31	180				
*6	L1	2	15μH				
*7	C32	33	220P				
*8	L3	4	220μH				
*9	R19	25	3A				
*10	C9	18	OPEN				
*11	C130	OPEN	470P				
*12	C403	404	OPEN				
*13	C401	406	OPEN				

Q	A	B	C	D	E	F	G
*14	C101	102	OPEN				
*15	F401	0.01					
*16	F401	7.04250V72	54250V				
*17	F402	3.54250V	OPEN				
*18	C408	409	OPEN				
*19	C38	30	1500P				
*20	C30	35	OPEN				
*21	C147	148	148				
*22	R405	408	OPEN				

REMARKS	PARIS NAME	REMARKS	PARIS NAME
NO MARK	ELECTROLYTIC CAPACITOR	NO MARK	CARBON FILM RESISTOR (1/5W)
NO MARK	TANTALUM CAPACITOR	NO MARK	CARBON FILM RESISTOR (1/4W)
NO MARK	CERAMIC CAPACITOR	NO MARK	METAL OXIDE FILM RESISTOR
NO MARK	POLYESTER FILM CAPACITOR	NO MARK	METAL FILM RESISTOR
NO MARK	POLYSTYRENE FILM CAPACITOR	NO MARK	METAL PLATE RESISTOR
NO MARK	MICA CAPACITOR	NO MARK	THICK BROWN CARBON FILM RESISTOR
NO MARK	POLYPROPYLENE FILM CAPACITOR	NO MARK	CEMENT MOUNTED RESISTOR
NO MARK	SEMICONDUCTIVE CERAMIC CAPACITOR	NO MARK	SEMI-VARIABLE RESISTOR
		NO MARK	CHIP RESISTOR

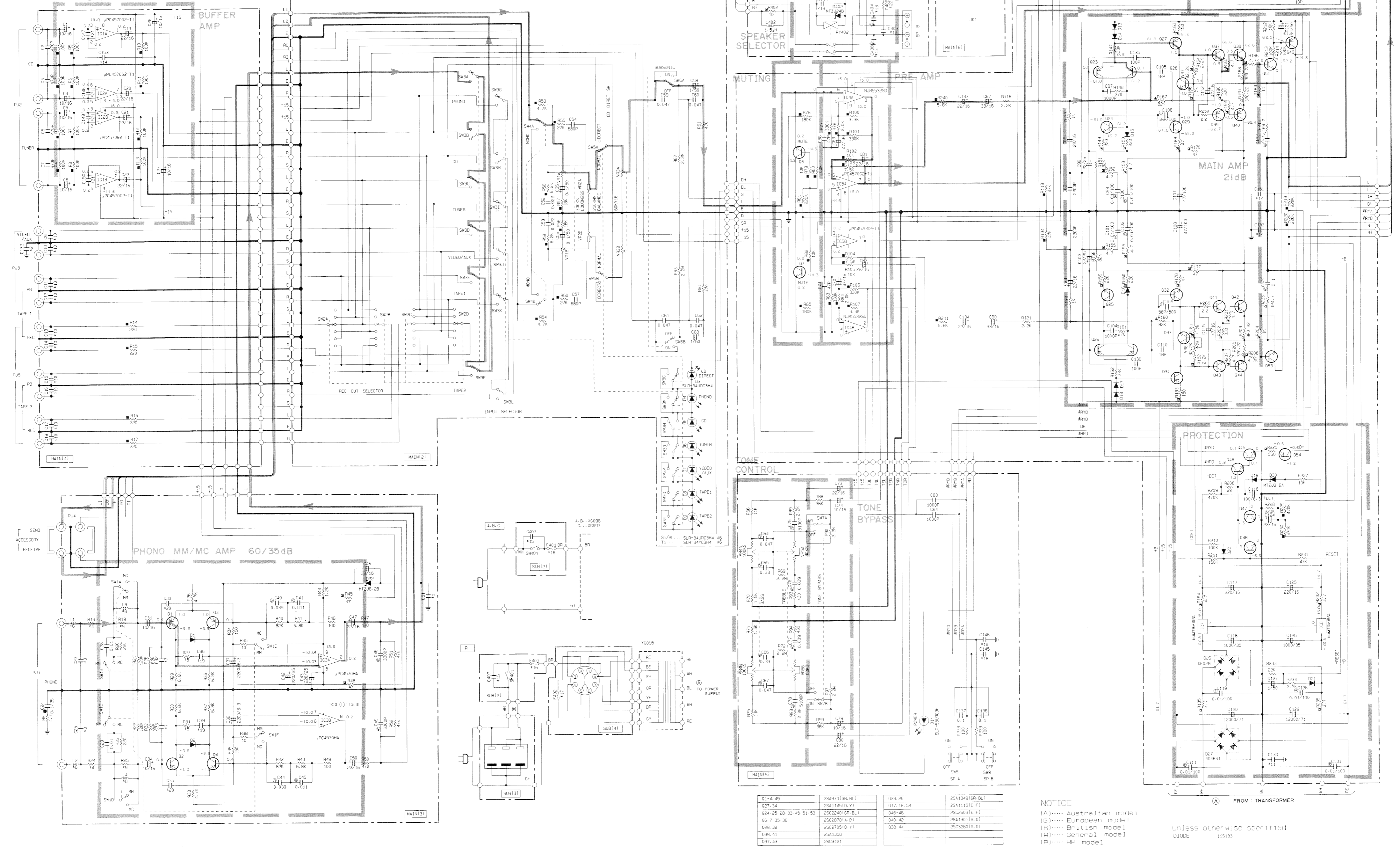

Q1-4	2SA970 (GR, BL)	Q23-28	2SA1349 (GR, BL)	
Q5	2SA1115	Q29-34	2SA1145 (D, Y)	
Q6	2SA2803	Q35-40	2SA1145 (D, Y)	
Q7	2SC2705 (O, Y)	Q41-46	2SC2401 (GR, B, I)	
Q8	2SA1145	Q47	Q48	2SA1301 (R, O)
Q9	2SA1358	Q49	Q50	2SC2705 (D, Y)
Q10	2SC3421	Q51	Q52	2SA1358
Q11	2SA1349	Q53	Q54	2SC3421
Q12	MT26.2B	Q55	Q56	2SC3421
Q13	1SS193	Q57	Q58	2SC3421
Q14	MT23.6A	Q59	Q60	2SC3421
Q15	SLR-55URC3H	Q61	Q62	2SC3421
Q16	SLR-34URC3H	Q63	Q64	2SC3421
Q17	SLR-34YC3H4	Q65	Q66	2SC3421
Q18	4D4B41	Q67	Q68	2SC3421
Q19	μPC4570HA	Q69	Q70	2SC3421
Q20	AN79M15F	Q71	Q72	2SC3421
Q21	AN78M15F	Q73	Q74	2SC3421
Q22	μPC4570G2-T1	Q75	Q76	2SC3421
Q23	NJM5532SD	Q77	Q78	2SC3421
Q24	NJM4568-A	Q79	Q80	2SC3421

NOTICE

- (A)..... Australian model
- (G)..... European model
- (B)..... British model
- (Q)..... General model
- (P)..... JP model

Unless otherwise specified
0100E 155133

PIN CONNECTION DIAGRAM OF TRANSISTORS, DIODES AND ICs.

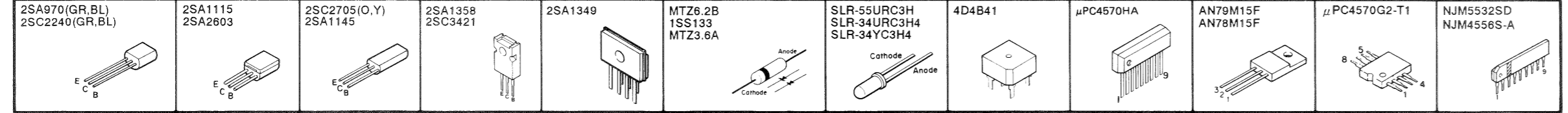

All voltages are measured with a 10MΩ/V DC electric volt meter.
Components having special characteristics are marked Δ and must be replaced with parts having specifications equal to those originally installed.
Schematic diagram is subject to change without notice.

PARTS LIST

■WARNING

Components having special characteristics are marked Δ and must be replaced with parts having specifications equal to those originally installed.

● Carbon resistors (1/6W or 1/4W) are not included in the ELECTRICAL PARTS list. For the parts No. of the carbon resistor, refer to p.22.

■ ELECTRICAL PARTS

Ref. No.	Part No.	Description	部 品 名	Remarks	Common Model	Markets	ランク
※	VH 27 01 00	Main Circuit Board	メ イ ン シ ー ト	Black, Silver		U,R,A,B	
※	VH 27 02 00	//	//	//		G	
※	VH 27 03 00	//	//	Titan		U,R,A,B	
※	VH 27 04 00	//	//	//		G	
※	VH 27 75 00	//	//	Black, Silver		C	
※	VH 27 76 00	//	//	Titan		C	
	FG 21 11 00	Ceramic Cap.	セ ラ コ ン	C139, 140			
	FG 21 21 00	//	//	C30, 35			
	FG 21 22 20	//	//	C23, 25			
	FG 21 22 20	//	//	C32, 33		U,C,R,A,B	
	FG 21 22 70	//	//	//		G	
	FG 21 31 00	//	//	C83, 84			
	FG 21 31 50	//	//	C36, 39		U,C,R,A,B	
	FG 11 32 70	//	//	//		G	
	FG 21 35 60	//	//	C51		G	
	FG 24 41 00	//	//	C28, 29			
	FG 24 41 00	//	//	C132		G	
	FG 24 44 70	//	//	C145, 146			
	FZ 00 50 30	Semiconductive Ceramic Cap.	半 導 体 セ ラ コ ン	C24			
	FU 35 15 60	Mica Cap.	F E マ イ カ コ ン	C106, 109			
	UA 25 33 30	Mylar Cap.	マ イ ラ ー コ ン	C48, 49			
	FA 15 35 10	//	//	C75, 78			
	UA 25 41 10	//	//	C41, 45			
	UA 25 43 90	//	//	C40, 44, 76, 77			
	UA 25 44 70	//	//	C64, 67			
	UA 25 51 00	//	//	C122, 123			
	UA 55 53 30	//	//	C65, 66			
	UD 11 11 80	Ceramic Cap Chip-Type	チ ッ プ 型 セ ラ コ ン	C105, 110			
	UD 11 14 70	//	//	C68, 71			
	UD 11 14 70	//	//	C147~150		G	
	UD 11 21 00	//	//	C135, 136			
	UD 11 24 70	//	//	C2, 3, 6, 7			
	UD 11 24 70	//	//	C9~18		G	
	UD 11 26 80	//	//	C54, 57			
	UD 11 31 00	//	//	C97, 104			
	UD 11 32 20	//	//	C89, 94			
	UD 11 42 20	//	//	C52, 53			
	UD 11 44 70	//	//	C59~62			
	UD 11 51 00	//	//	C137, 138			
	UD 11 51 00	//	//	C151~153		G	
	UH 11 81 00	Electrolytic Cap.	ケ ミ コ ン	C116			
	UH 23 71 00	//	//	C1, 4, 5, 8, 26, 27, 31, 34, 74, 79, 92, 141, 142			
	UH 23 72 20	//	//	C19~22, 47, 50, 73, 80~82, 124			
	UH 13 73 30	//	//	C46			
	UH 23 82 20	//	//	C117, 125			
	UH 24 72 20	//	//	C98, 103			
	UW 94 82 20	//	//	C42, 43			
	UH 26 51 00	//	//	C55, 56			
	UH 26 61 00	//	//	C121, 127			
	UW 81 92 20	//	//	C37, 38			
	UW 95 91 00	//	//	C118, 126			
	Ui 33 72 20	//	//	C86, 93, 133, 134			
	Ui 33 73 30	//	//	C87, 90			

※New Parts (新規部品) NR

AX-530

Ref. No.	Part No.	Description	部 品 名	Remarks	Common Model	Markets	ランク
	Ui 33 74 70	Electrolytic Cap.	47 μ F 16V	ケ ミ コ ン	C69,70,112,115		
	Ui 36 31 00	//	1 μ F 50V	//	C58,63		
	UJ 29 74 70	//	47 μ F 100V	//	C107,108		
	VE 44 28 00	//	12000 μ F 71V	//	C120,129		
	UT 45 41 00	Polypropylene Film Cap.	0.01 μ F 100V	ポ リ プ ロ コ ン	C99~102,111,119,128,131		
	UT 45 41 00	//	0.01 μ F 100V	//	C130	G	
	VA 98 35 00	Coil	15 μ H	コ イ ル	L1,2	G	
	VA 98 36 00	//	220 μ H	//	L3,4	G	
	HL 31 34 70	Metal Oxide Resistor	4.7 Ω 1W	酸 金 抵 抗	R216,223		
	HL 31 51 20	//	120 Ω 1W	//	R242,243		
※	VD 95 24 00	//	0.22 Ω 3W	//	R188,191,203,205		
	HV 45 34 70	Flam Proof Carbon Resistor	4.7 Ω 1/4W	不 燃 化 カ ー ボ ン 抵 抗	R152,153,155,156,184,185,187,192,201,207,232,235		
	HV 45 44 70	//	47 Ω 1/4W	//	R168,170,177,178		
	HV 45 45 60	//	56 Ω 1/4W	//	R126,129		
	HV 45 51 00	//	100 Ω 1/4W	//	R45,48		
	HV 45 51 50	//	150 Ω 1/4W	//	R163,183		
	HV 45 52 20	//	220 Ω 1/4W	//	R149,150,159,160		
	HV 45 53 30	//	330 Ω 1/4W	//	R190,202		
	HV 45 55 60	//	560 Ω 1/4W	//	R225		
	HV 45 61 00	//	1k Ω 1/4W	//	R189,204		
	HV 45 61 20	//	1.2k Ω 1/4W	//	R166,181		
	HV 45 62 20	//	2.2k Ω 1/4W	//	R164,182		
	HV 45 64 70	//	4.7k Ω 1/4W	//	R186,206		
	RA 25 78 20	Chip Resistor	82k Ω 1/8W	チ ッ プ 型 抵 抗	R167,180		
	RA 25 52 20	//	220 Ω 1/8W	//	R14~17		
	RA 25 62 00	//	2k Ω 1/8W	//	R78~84		
	RA 25 63 30	//	3.3k Ω 1/8W	//	R100,107		
	RA 25 64 70	//	4.7k Ω 1/8W	//	R53,54		
	RA 25 65 60	//	5.6k Ω 1/8W	//	R240,241		
	RA 25 67 50	//	7.5k Ω 1/8W	//	R103,104		
	RA 25 68 20	//	8.2k Ω 1/8W	//	R56,59		
	RA 25 71 00	//	10k Ω 1/8W	//	R79,82,102,105		
	RA 25 71 80	//	18k Ω 1/8W	//	R57,58		
	RA 25 72 70	//	27k Ω 1/8W	//	R55,60		
	RA 25 74 70	//	47k Ω 1/8W	//	R118,134		
	RA 25 81 00	//	100k Ω 1/8W	//	R1~8,10~13,80		
	RA 25 81 80	//	180k Ω 1/8W	//	R76,85		
	RA 25 82 20	//	220k Ω 1/8W	//	R81,219,220		
	RA 25 83 30	//	330k Ω 1/8W	//	R77,83,101,106		
	RA 25 84 70	//	470k Ω 1/8W	//	R229,230		
	VB 86 12 00	Pre-Set Potentiometer	B2.2k Ω	半 固 定 抵 抗	VR7,8	} Interchangeable	
	VB 86 29 00	//	B2.2k Ω	//	//		
	VC 23 71 00	Potentiometer	250kMN	可 変 抵 抗 器	VR2		
	VC 23 72 00	//	80k特	//	VR5		
	VC 23 73 00	//	100k特	//	VR4		
	VC 23 74 00	//	60kY	//	VR3		
	VC 29 74 00	//	300k特	//	VR1		
	iA 09 70 00	Transistor	2SA970(GR,BL)	ト ラ ン ジ ス タ	Q1~4,49		
	iA 11 15 10	//	2SA1115(E,F)	//	Q17,18,54		

※New Parts (新規部品) NR

Ref. No.	Part No.	Description	部 品 名	Remarks	Common Model	Markets	ランク
	iA 11 45 00	Transistor	2SA1145(O,Y)	ト ラ ン ジ ス タ	Q27,34		
	iA 13 49 00	//	2SA1349(GR,BL)	//	Q23,26		
	iC 22 40 00	//	2SC2240(GR,BL)	//	Q24,25,28,33,45,51,53		
	iC 26 03 20	//	2SC2603(E,F)	//	Q46~48		
	iC 27 05 00	//	2SC2705(O,Y)	//	Q6,7,35,36		
	iX 60 85 10	//	2SA1358	//	Q39,41		
	iX 60 85 20	//	2SC3421	//	Q37,43		
	iF 00 34 50	Diode	ISS133	ダ イ オ ード	D1,2,13~21,28,29		
	VG 43 80 00	Zener Diode	MTZJ6.2B	ツェナーダイオード	D22		
	VG 43 62 00	//	MTZJ3.6A	//	D30		
	iF 00 42 70	LED	SLR-55URC3H	L E D	D11		
	VC 40 76 00	//	SLR-34URC3H4	//	D4~9 Silver, Black		
	VH 25 67 00	//	SLR-34YC3H4	//	// Titan		
	VC 40 76 00	//	SLR-34URC3H4	//	D3		
	iH 00 11 60	Diode Bridge	4D4B4I	ダイオードブリッジ	D27		
	VE 36 79 00	//	DF02M	//	D26		
	XB 24 70 01	IC	μPC4570HA	I C	IC3		
	XC 63 20 01	//	NJM5532SD	//	IC4		
	XF 29 1A 00	//	μPC4570G2-T1	//	IC1,2,5		
※	XE 58 4A 00	//	NJM78M15FA	//	IC7		
※	XG 50 5A 00	//	NJM79M15FA	//	IC8		
	iG 07 74 10	//	NJM4556S-A	//	IC9		
	VC 17 67 00	Push Switch	NS4-2	プッシュスイッチ	SW5		
	VC 24 55 00	//	NS2-2	//	SW6,8,9		
	VC 36 99 00	//	6-2	//	SW1		
※	VH 58 40 00	//	2-2	//	SW7		
	VD 15 63 00	//	NS2-2	//	SW4		
	VC 23 77 00	//	NS4-2	//	SW3		
	VC 23 78 00	Rotary Switch	SRZ-U	ロータリースイッチ	SW2		
	LB 30 16 90	Phone Jack		ヘッドホンジャック	JK1		
	LB 20 22 90	Pin Jack	2P	ピンジャック	PJ1		
	LB 40 10 30	//	4P	//	PJ2~4		
	LB 60 60 90	//	6P	//	PJ5		
	VA 72 53 00	Holder, Wire	3P	パラレルホルダー			
	VA 72 55 00	//	5P	//			
	VA 72 58 00	//	8P	//			
	VA 72 62 00	//	12P	//			
	RA 25 00 00	Chip Resistor	0Ω 1/8W	チップ型抵抗	J1~10		
※	VH 58 39 00	Slide Switch		スライドスイッチ			
	VA 82 15 00	Radiator		放 熱 板			
	BB 06 95 10	Land Metal Fitting		ラ ン ド 金 具			
	BB 07 13 60	Screw Terminal		ネ ジ 端 子			
	VA 11 91 00	Radiator Fin		放 熱 フ ィ ン			
	EZ 00 13 50	Cup Screw	3×14 FCRM3-BI	カップネジ (Bタイト)			

※New Parts (新規部品) NR

Ref. No.	Part No.	Description	部 品 名	Remarks	Common Model	Markets	ランク
※	VH 27 35 00	Sub Circuit Board	サ ブ シ ー ト			U,C	
※	VH 27 36 00	//	//			R	
※	VH 27 37 00	//	//			A,B	
※	VH 27 40 00	//	//			G	
	Fi 41 41 00	Ceramic Cap. 0.01 μ F VA-1	セ ラ コ ン	C407			
	FG 24 42 20	// 0.022 μ F 50V	//	C402,405		G	
	FG 24 44 70	// 0.047 μ F 50V	//	C408,409		G	
	UA 25 41 00	Mylar Cap. 0.01 μ F 50V	マ イ ラ ー コ ン	C401,403,404,406		G	
	GD 90 04 70	Coil Output 1.7 μ H	ア ウ ト プ ッ ト コ イ ル	L401,402			
	HL 31 61 80	Metal Oxide Film Resistor 1.8k Ω 2W	酸 金 抵 抗	R403,404			
	HV 45 41 00	Flam Proof Carbon Resistor 10 Ω 1/4W	不 燃 化 カ ー ボ ン 抵 抗	R401,402			
	VG 44 25 00	Zener Diode MTZJ24B	ツ ェ ナ ー ダイ オ ー ド	D401,402			
	KC 00 19 40	Relay DH24D2-OTM	リ レ ー	R401,402	} Inter changeable		
	KC 00 20 00	// JR2A-DC24V	//	//			
	VC 40 97 00	Push Switch	プ ッ シ ュ ス イ ッ チ	SW401			
	KB 00 03 70	Fuse 3.5A 250V	ヒ ュ ー ズ	F402			
	KB 00 13 00	// 7.0A 250V	//	F401		R	
	KB 00 15 20	// 7.0A 125V	//	//		U,C	
	KB 00 29 80	// T2.5A 250V	//	//		A,B,G	
	VA 96 18 00	Voltage Selector	電 圧 切 換 器			R	
	LB 20 10 60	Fuse Holder Pin YSH403T	ヒ ュ ー ズ ホ ル ダ ー ピ ン			A,B,G	
	LB 20 19 70	// 23165081	//			U,C,R	
	LB 60 81 70	AC Outlet	A C ア ウ ト レ ッ ト			U,C,R	
	VC 31 37 00	Speaker Terminal 8P	ス ピ ー カ ー タ ー ミ ナ ル			U,C,R,A,B	
	VC 72 09 00	// 8P	//			G	

※New Parts (新規部品) NR

EXPLODED VIEW

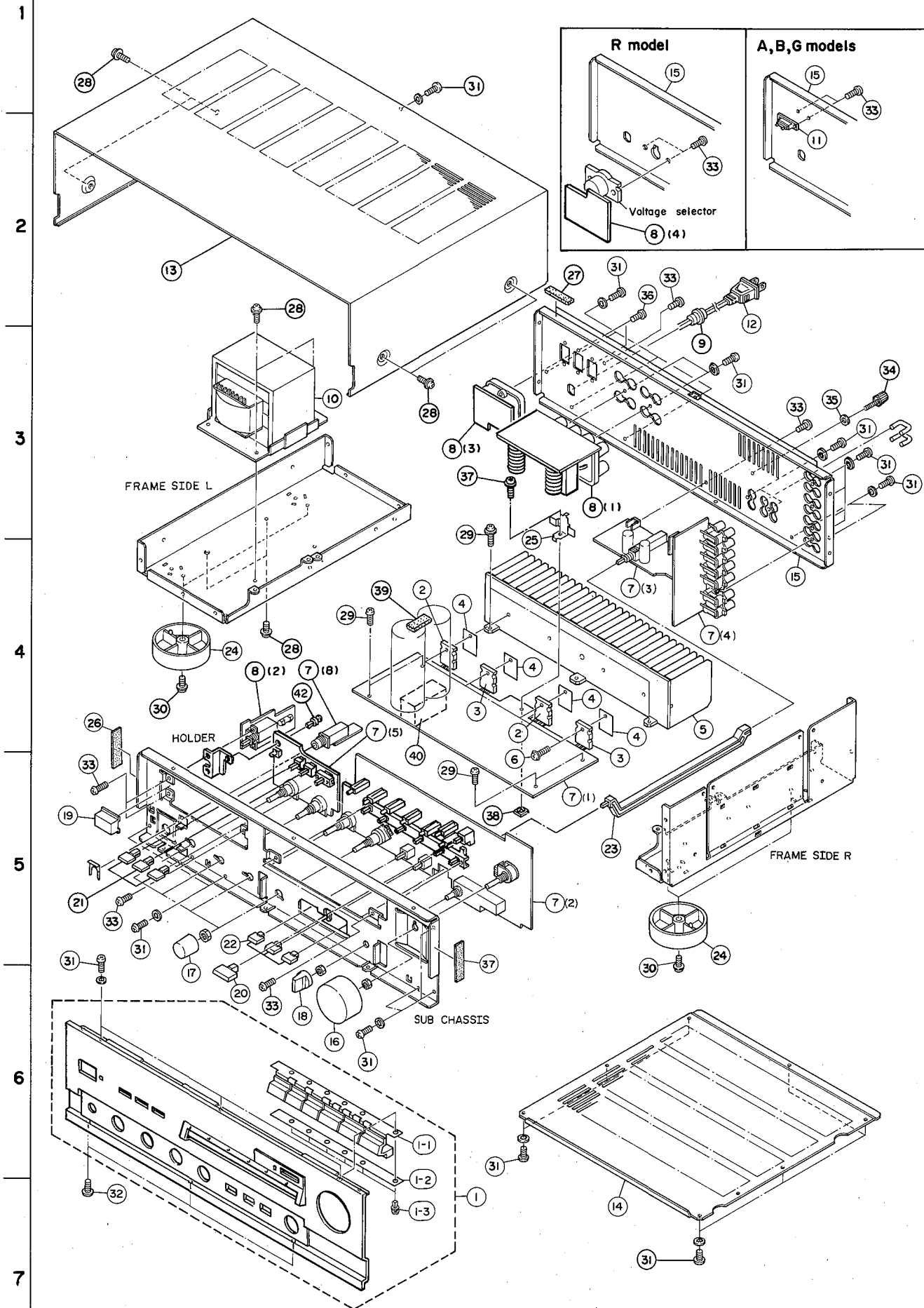

MECHANISM PARTS

Notes) ϕ : Diameter

Ref. No.	Part No.	Description	部品名	Remarks	Common Model	Markets	ランク
※	1	VH 26 97 00	Front Panel Unit	パネルユニット	Black		
※	//	VH 26 98 00	//	//	Silver		
※	//	VH 26 99 00	//	//	Titan		
※	I-1	CB 65 91 90	Button, Input	ボタンインプット	Black		
※	//	CB 65 92 00	//	//	Silver		
※	//	VE 54 48 00	//	//	Titan		
※	I-2	AA 63 22 00	Spacer	スペーサー			
※	I-3	CB 09 96 00	Plastic Rivet	プラスチックリベット			
※	2	IX 60 81 10	Transistor	トランジスタ	Q40,42		
※	3	IX 60 81 20	//	//	Q38,44		
※	4	VC 39 72 00	Sheet	シンエツシート	Interchangeable		
※	//	VC 65 78 00	//	デンカシート			
※	5	BA 09 55 60	Heat Sink	放熱シート			
※	6	EK 33 00 20	BW Head Tapping Screw	3×14(ϕ 10) ZMC2-BI	BWヘッドタッピングネジ		
※	7	VH 27 01 00	Main Circuit Board	メインシート	Black, Silver	U, R, A, B	
※	//	VH 27 02 00	//	//	//	G	
※	//	VH 27 03 00	//	//	Titan	U, R, A, B	
※	//	VH 27 04 00	//	//	//	G	
※	//	VH 27 75 00	//	//	Black, Silver	C	
※	//	VH 27 76 00	//	//	Titan	C	
※	8	VH 27 35 00	Sub Circuit Board	サブシート		U, C	
※	//	VH 27 36 00	//	//		R	
※	//	VH 27 37 00	//	//		A, B	
※	//	VH 27 40 00	//	//		G	
※	9	CB 62 01 90	Cord Stopper	CM-22B	コードストッパー	R, A, B, G	
※	//	CB 62 02 00	//	CM-22C	//	U, C	
※	10	XG 09 3A 00	Power Transformer		電源トランス	U	
※	//	XG 09 4A 00	//		//	C	
※	//	XG 09 5A 00	//		//	R	
※	//	XG 09 6A 00	//		//	A, B	
※	//	XG 09 7A 00	//		//	G	
※	11	VD 61 41 00	Terminal Board	2P	中継端子台	A, B, G	
※	12	MG 00 22 20	Power Cord	10A 125V	電源コード	U, C	
※	//	MG 00 16 30	//	6A 250V	//	R	
※	//	MG 00 23 10	//	7.5A 250V	//	A	
※	//	MG 00 23 30	//	300/300V	//	B	
※	//	MG 00 23 20	//	2.5A 250V	//	G	
※	13	VH 16 15 00	Top Cover		トップカバー	Black	
※	//	VH 16 16 00	//		//	Silver	
※	//	VH 16 17 00	//		//	Titan	
※	14	AA 63 13 20	Bottom Cover		ボトムカバー		
※	15	VH 58 09 00	Rear Panel		リアパネル		C
※	//	VH 22 81 00	//		//	U	
※	//	VH 22 82 00	//		//	R	
※	//	VH 22 83 00	//		//	A, B	
※	//	VH 22 84 00	//		//	G	
※	16	BA 09 56 30	Knob	ϕ 45	ツマミ	Black VOLUME	
※	//	BA 09 56 40	//	ϕ 45	//	Silver //	
※	//	VG 76 86 00	//	ϕ 45	//	Titan //	
※	17	CB 65 92 50	//		//	Black	
※	//	CB 65 92 60	//		//	Silver	
※	//	VE 54 41 00	//		//	Titan	

※New Parts (新規部品) NR

Parts List for Carbon Resistors

Ref. No.	Part No.	Description	部 品 名	Remarks	Common Model	Markets	ランク
18	CB 66 11 00	Knob	ツ マ ミ	Black REC OUT			
//	CB 66 11 10	//	//	Silver //			
//	VE 54 42 00	//	//	Titan //			
19	CB 66 08 10	//	//	Black POWER			
//	CB 66 08 00	//	//	Silver //			
//	VE 54 43 00	//	//	Titan //			
20	VH 19 27 00	Button	ボ タ ン	Black CD DIRECT			
//	VH 19 28 00	//	//	Silver //			
//	VH 19 29 00	//	//	Titan //			
21	CB 66 07 90	//	//	Black			
//	CB 66 07 80	//	//	Silver			
//	VE 01 28 00	//	//	Titan			
22	CB 65 92 70	//	//	Black			
//	CB 65 92 80	//	//	Silver			
//	VE 54 46 00	//	//	Titan			
23	CB 65 93 20	Rod	ロ ッ ド				
24	VE 18 53 00	LEG	脚	Titan			
//	CB 66 09 50	//	//	Black, Silver			
25	BB 07 09 60	TR Pusher	T R プ ッ シ ャ ー				
※	26	VF 66 18 00	Pad	パ ッ ド			
27	VE 86 34 00	Cushion	ク ッ シ ョ ン				
28	EX 60 10 60	BW Head Screw	4×8 GRAY B W ヘ ッ ド 小 ネ ジ	Titan			
//	EX 60 10 80	Cup Screw	4×8 FCM3-BI カ ッ プ ネ ジ	Black			
//	EZ 00 13 10	Cup Tight Screw	4×8 FNM3-3g //	Silver			
29	EK 33 60 10	BW Head Tapping Screw	3×8(φ10) FCRM3 B W ヘ ッ ド タ ッ ピ ン グ ネ ジ				
30	EZ 00 16 10	Cup Screw	3×8 FCRM3-BI カ ッ プ ネ ジ (B タ イ ト)				
31	EZ 00 04 60	Tapping Head Screw	3×8 FCM3-BI ボ ン デ ィ ン グ ネ ジ				
32	EI 33 00 66	Binding Head Tapping Screw	3×6 ZMC2-BI バ イ ン ド タ ッ ピ ン グ ネ ジ	PACK			
33	ED 33 00 66	Binding Head Screw	3×6 FCRM3-BI バ イ ン ド 小 ネ ジ				
34	AA 62 73 10	Terminal, Ground	3×13 G N D タ ー ミ ナ ル				
35	EV 90 13 60	Sems Plain Washer	φ10×φ3.6×t0.8 FNM3-3g セ ム ス 平 座 金				
36	EI 33 00 86	Binding Head Tapping Screw	3×8 FCRM3-BI バ イ ン ド タ ッ ピ ン グ ネ ジ	PACK			
37	ED 03 00 86	Binding Head Screw	3×8 ZMC2-Y バ イ ン ド 小 ネ ジ				
38	VF 45 23 00	Push Nut	プ ッ シ ュ ナ ッ ト				
※	39	VH 11 80 00	Damper	12×25×t5 ダ ン パ ー			
※	40	VH 60 47 00	//	20×40×t30 //			
41	EX 60 10 80	Cup Screw	4×8 FCM3-BI カ ッ プ ネ ジ				
42	CB 09 96 00	Plastic Rivet	プ ラ ス チ ッ ク リ ヱ ッ ト				

※New Parts (新規部品) NR

Value	1/4W Type Part No.	1/6W Type Part No.	Value	1/4W Type Part No.	1/6W Type Part No.
1.0 Ω	HJ353100	HF85 3100	12K Ω	HJ35 7120	HF85 7120
1.8 "	HJ353180	※	15 "	HJ35 7150	HF85 7150
2.2 "	HJ353220	HF853220	18 "	HJ35 7180	HF85 7180
3.3 "	HJ353330	HF853330	22 "	HJ35 7220	HF85 7220
4.7 "	HJ353470	HF853470	27 "	HJ35 7270	HF85 7270
5.6 "	HJ353560	HF853560	33 "	HJ35 7330	HF85 7330
10 "	HJ354100	HF854100	39 "	HJ35 7390	HF85 7390
15 "	HJ354150	HF854150	47 "	HJ35 7470	HF85 7470
22 "	HJ354220	HF854220	56 "	HJ35 7560	HF85 7560
27 "	HJ354270	HF854270	68 "	HJ35 7680	HF85 7680
33 "	HJ354330	HF854330	82 "	HJ35 7820	HF85 7820
39 "	HJ354390	HF854390	91 "	HJ35 7910	HF85 7910
47 "	HJ354470	HF854470	100 "	HJ358100	HF858100
56 "	HJ354560	HF854560	120 "	HJ358120	HF858120
68 "	HJ354680	HF854680	150 "	HJ358150	HF858150
82 "	HJ354820	HF854820	180 "	HJ358180	HF858180
100 "	HJ355100	HF855100	220 "	HJ358220	HF858220
110 "	HJ355110	HF855110	270 "	HJ358270	HF858270
120 "	HJ355120	HF855120	330 "	HJ358330	HF858330
150 "	HJ355150	HF855150	390 "	HJ358390	HF858390
160 "	HJ355160	※	470 "	HJ358470	HF858470
180 "	HJ355180	HF855180	560 "	HJ358560	HF858560
220 "	HJ355220	HF855220	680 "	HJ358680	HF858680
270 "	HJ355270	HF855270	820 "	HJ358820	HF858820
330 "	HJ355330	HF855330	1.0M Ω	HJ359100	HF859100
390 "	HJ355390	HF855390	1.2 "	HJ359120	※
470 "	HJ355470	HF855470	1.5 "	HJ359150	HF859150
510 "	※	HF855510	1.8 "	HJ359180	HF859180
560 "	HJ355560	HF855560	2.2 "	HJ359220	HF859220
680 "	HJ355680	HF855680	3.3 "	HJ359330	HF859330
820 "	HJ355820	HF855820	3.9 "	HJ359390	※
910 "	HJ355910	HF855910	4.7 "	HJ359470	HF859470
1.0K Ω	HJ356100	HF856100			
1.2 "	HJ356120	HF856120			
1.5 "	HJ356150	HF856150			
1.8 "	HJ356180	HF856180			
2.0 "	HJ356200	HF856200			
2.2 "	HJ356220	HF856220			
2.4 "	HJ356240	HF856240			
2.7 "	HJ356270	HF856270			
3.0 "	HJ356300	HF856300			
3.3 "	HJ356330	HF856330			
3.6 "	HJ356360	HF856360			
3.9 "	HJ356390	HF856390			
4.7 "	HJ356470	HF856470			
5.1 "	HJ356510	HF856510			
5.6 "	HJ356560	HF856560			
6.8 "	HJ356680	HF856680			
8.2 "	HJ356820	HF856820			
9.1 "	HJ356910	HF856910			
10 "	HJ357100	HF857100			

