

STEREO AMPLIFIER AX-596

SERVICE MANUAL

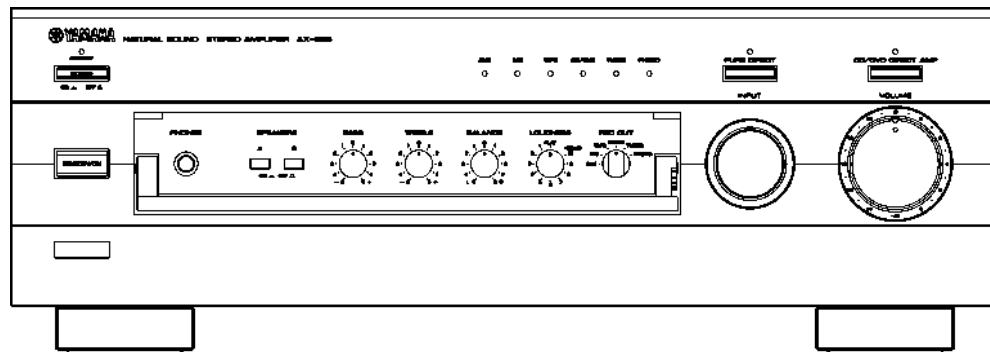
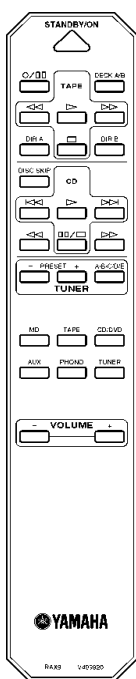

IMPORTANT NOTICE

This manual has been provided for the use of authorized YAMAHA Retailers and their service personnel. It has been assumed that basic service procedures inherent to the industry, and more specifically YAMAHA Products, are already known and understood by the users, and have therefore not been restated.

WARNING: Failure to follow appropriate service and safety procedures when servicing this product may result in personal injury, destruction of expensive components, and failure of the product to perform as specified. For these reasons, we advise all YAMAHA product owners that any service required should be performed by an authorized YAMAHA Retailer or the appointed service representative.

IMPORTANT: The presentation or sale of this manual to any individual or firm does not constitute authorization, certification or recognition of any applicable technical capabilities, or establish a principle-agent relationship of any form.

The data provided is believed to be accurate and applicable to the unit(s) indicated on the cover. The research, engineering, and service departments of YAMAHA are continually striving to improve YAMAHA products. Modifications are, therefore, inevitable and specifications are subject to change without notice or obligation to retrofit. Should any discrepancy appear to exist, please contact the distributor's Service Division.

WARNING: Static discharges can destroy expensive components. Discharge any static electricity your body may have accumulated by grounding yourself to the ground buss in the unit (heavy gauge black wires connect to this buss).

IMPORTANT: Turn the unit OFF during disassembly and part replacement. Recheck all work before you apply power to the unit.

CONTENTS

SPECIFICATIONS	1	BLOCK DIAGRAM	6
TO SERVICE PERSONNEL	2	μ-COM DATA	7
IMPEDANCE SELECTOR	2	PRINTED CIRCUIT BOARD	8-15
REAR PANELS	3	SCHEMATIC DIAGRAM	16-17
INTERNAL VIEW	5	PARTS LIST	18-27
DISASSEMBLY PROCEDURES	5	REMOTE CONTROL TRANSMITTER	28
ADJUSTMENTS	6		



このサービスマニュアルは、エコマーク認定の再生紙を使用しています。
This Service Manual uses recycled paper.

■ SPECIFICATIONS

■ Power Section

Minimum RMS Output Power		
8Ω, 20Hz to 20kHz, 0.015% THD		100W + 100W
Maximum Output Power (EIAJ)		
1kHz, 10% THD		
8Ω/6Ω		145W / 170W
Dynamic Power (IHF)		
8/6/4/2Ω		140/170/220/290W
DIN Standard Output Power		
4Ω, 1kHz, 0.7% THD		150W
IEC Output Power		
8Ω, 1kHz, 0.015% THD		110W
Power Band Width		
8Ω, 50W, 0.03% THD		10Hz to 50kHz
Damping Factor		
8Ω, 20Hz to 20kHz		320
Frequency Response		
20Hz to 20kHz		0 ±0.5dB
20Hz to 100kHz		0 +0.5, -3dB
Total Harmonic Distortion (20Hz to 20kHz)		
CD/DVD to SP OUT (8Ω, 50W)		0.008%
Signal to Noise Ratio (IHF-A-Network)		
CD/DVD (Input Shorted, CD/DVD DIRECT AMP ON)		110dB
PHONO (Input Shorted)		92dB
Residual Noise (IHF-A-Network)		
CD/DVD DIRECT AMP ON		35μV

■ Control Section

Input Sensitivity / Impedance		
CD/DVD etc.		150mV / 47kΩ
PHONO		2.5mV / 47kΩ
Output Level / Impedance		
PRE OUT		1V / 1.2kΩ
REC OUT		150mV / 0.6kΩ
Headphone Jack Rated Output / Impedance		
		0.33V / 680Ω
Channel Separation		
CD/DVD (Input 5.1kΩ Terminated) 1kHz/10kHz		65 / 50dB
Tone Control Characteristics		
BASS		±10dB (20Hz)
TREBLE		±10dB (20kHz)
Continuous Loudness Control		
Attenuation		-30dB (1kHz)

■ General

Power Supply	
U, C models	AC120V, 60Hz
B, G models	AC230V, 50Hz
A model	AC240V, 50Hz
R, T models	AC110/120/220/240V, 50/60Hz
Power Consumption	
	Approx. 220W
AC Outlets	
3 switched outlets	
U, C, G, R, T models	100W max, total
1 switched outlets	
A, B models	100W max, total
Dimensions (W x H x D)	
	435 x 151 x 396mm (17-1/8" x 5-15/16" x 15-9/16")
Weight	
	11.0 kg (23lbs. 5oz.)
Accessories	
	Remote Control Transmitter Batteries
Color	
	Gold / Black / Titan

* Specifications subject to change without notice.

- | | | | |
|---------|-----------------|---------|---------------|
| U | U.S.A. model | C | Canada model |
| G | European model | B | British model |
| A | Australia model | T | China model |
| R | General model | | |

• DIMENSIONS

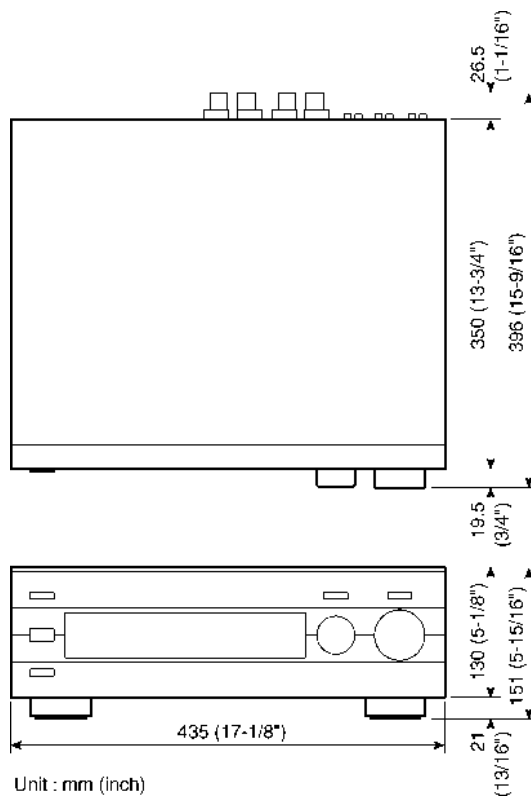

■ TO SERVICE PERSONNEL

1. Critical Components Information

Components having special characteristics are marked \leq and must be replaced with parts having specifications equal to those originally installed.

2. Leakage Current Measurement (For 120V Models Only)

When service has been completed, it is imperative to verify that all exposed conductive surfaces are properly insulated from supply circuits.

- Meter impedance should be equivalent to 1500 ohm shunted by $0.15\mu\text{F}$.
- Leakage current must not exceed 0.5mA.
- Be sure to test for leakage with the AC plug in both polarities.

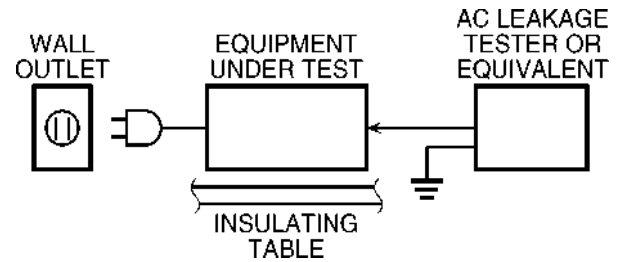

WARNING: CHEMICAL CONTENT NOTICE!

The solder used in the production of this product contains LEAD. In addition, other electrical/electronic and /or plastic (where applicable) components may also contain traces of chemicals found by the California Health and Welfare Agency (and possibly other entities) to cause cancer and/or birth defects or other reproductive harm.

DO NOT PLACE SOLDER, ELECTRICAL/ELECTRONIC OR PLASTIC COMPONENTS IN YOUR MOUTH FOR ANY REASON WHATSOEVER!

Avoid prolonged, unprotected contact between solder and your skin! When soldering, do not inhale solder fumes or expose eyes to solder/flux vapor!

If you come in contact with solder or components located inside the enclosure of this product, wash your hands before handling food.

■ IMPEDANCE SELECTOR

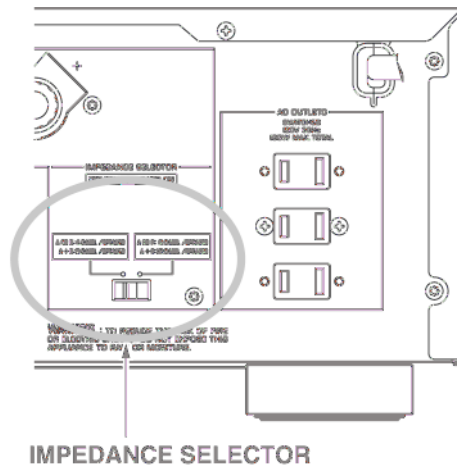

WARNING:

Do not change the IMPEDANCE SELECTOR switch setting while the power to this unit is on, otherwise this unit may be damaged.

ご注意:

インピーダンスセレクターの切り換えは、必ず電源を切ってから行ってください。電源を入れたまま行くと、故障の原因となります。

REAR PANELS

U model

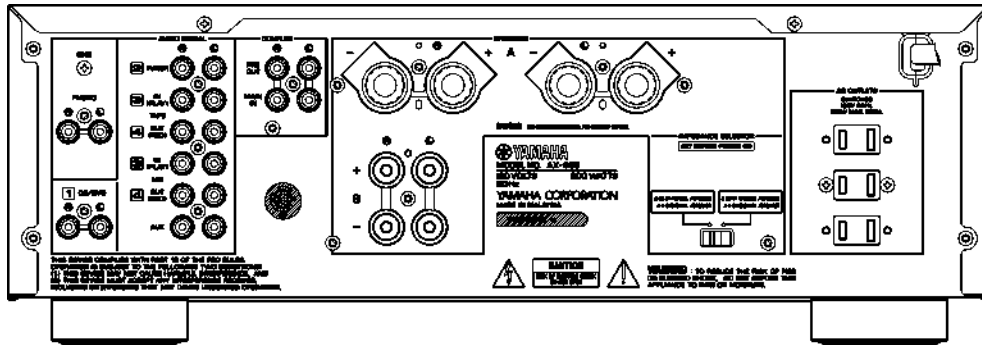

C model

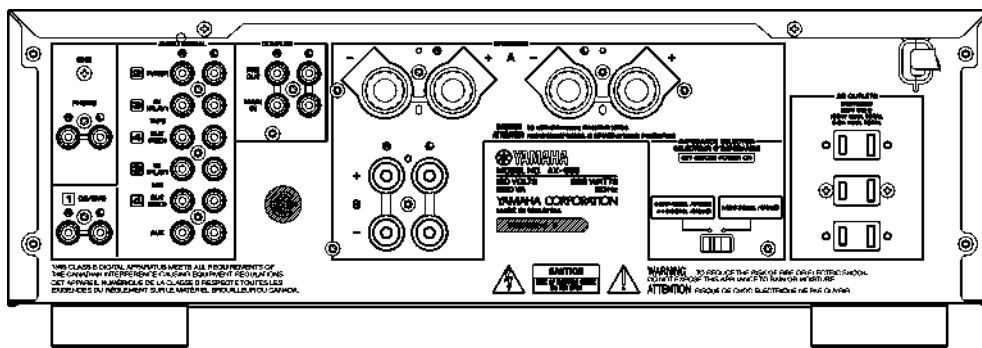

R model

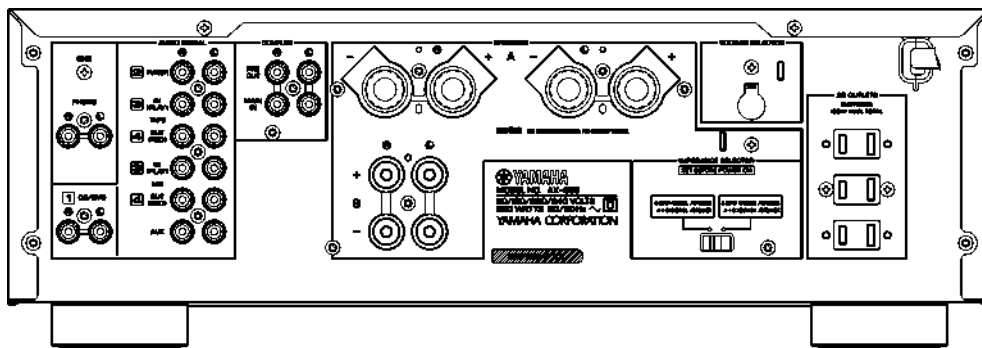

A model

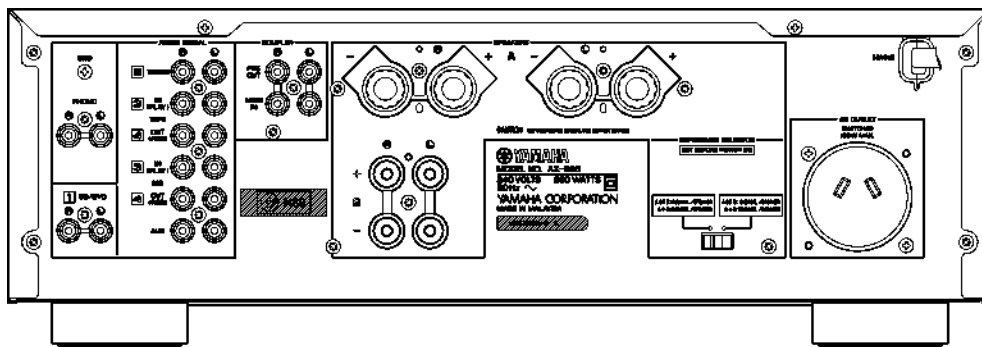

B model

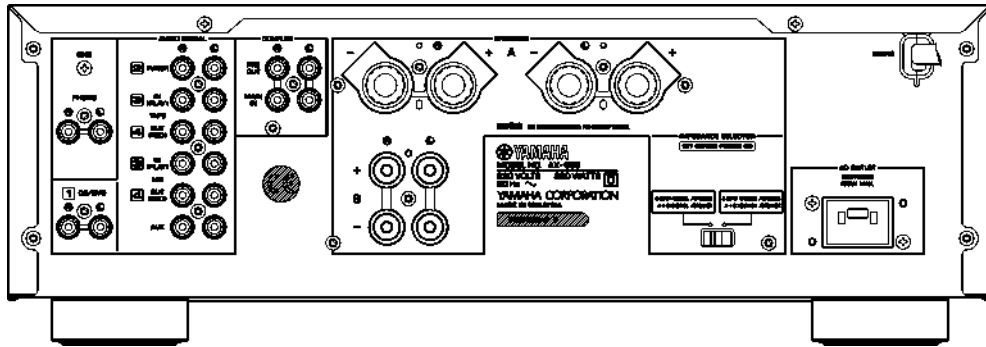

G model

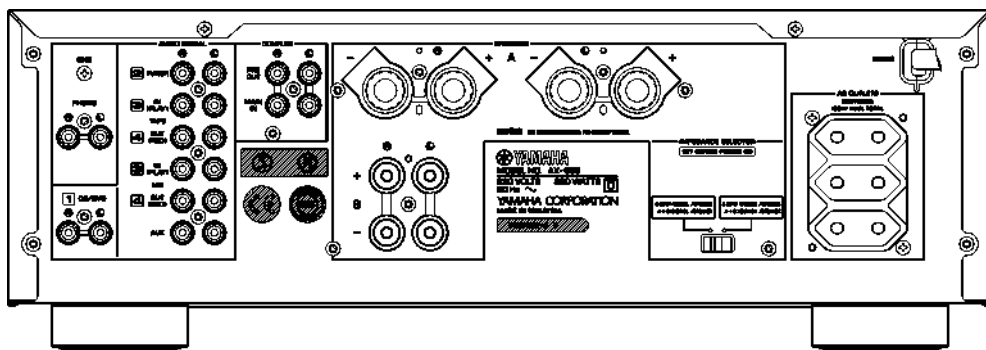

T model

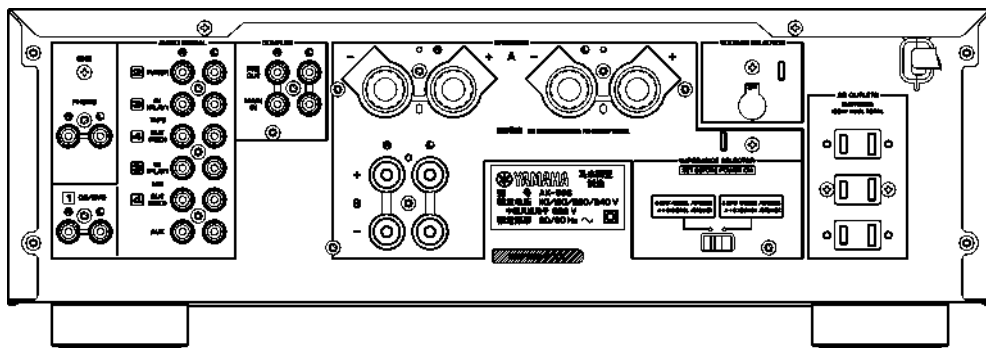

J model

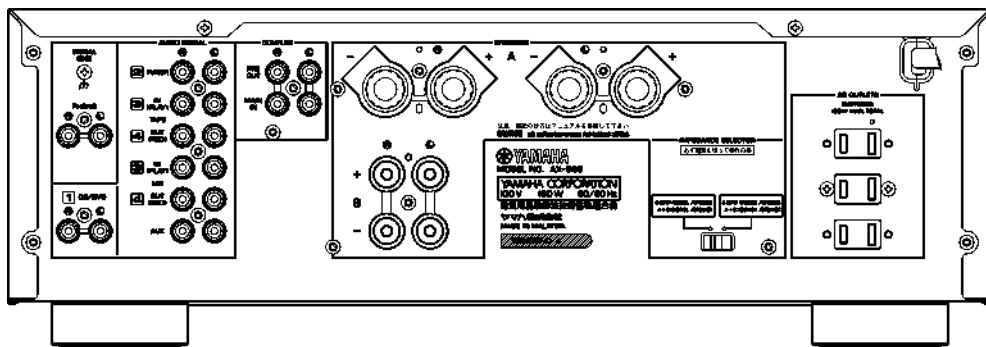

INTERNAL VIEW

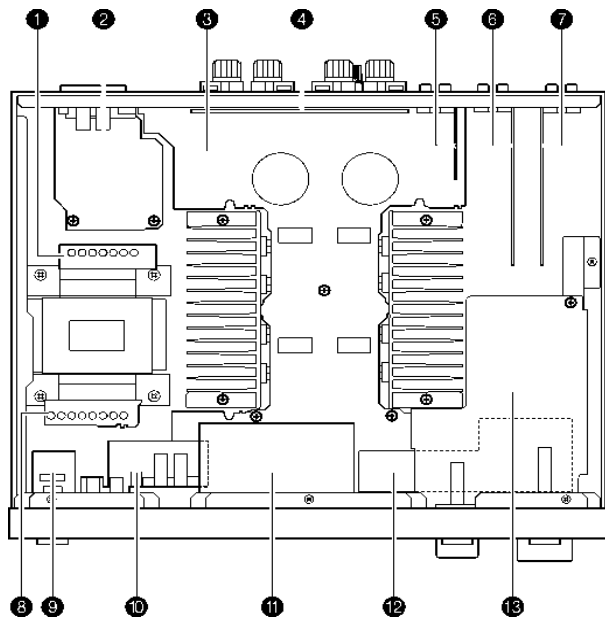

- ① MAIN P.C.B. (9)
- ② MAIN P.C.B. (2)
- ③ MAIN P.C.B. (1)
- ④ MAIN P.C.B. (5)
- ⑤ FUNCTION P.C.B. (13)
- ⑥ FUNCTION P.C.B. (4)
- ⑦ FUNCTION P.C.B. (5)
- ⑧ MAIN P.C.B. (10)
- ⑨ MAIN P.C.B. (11)
- ⑩ FUNCTION P.C.B. (7)
- ⑪ FUNCTION P.C.B. (6)
- ⑫ FUNCTION P.C.B. (3)
- ⑬ FUNCTION P.C.B. (1)

DISASSEMBLY PROCEDURES

(Remove parts in the order as numbered.)
Disconnect the power cord from the AC outlet.

1. Removal of Top Cover

- a. Remove 6 screws (1) in Fig. 1.

2. Removal of Front Panel

- a. Remove 6 screws (2) in Fig. 1.

3. Removal of Sub Chassis

- a. Remove 4 plastic rivets (3) in Fig. 1, then remove the Side Plates.
- b. Remove 5 screws (4) in Fig. 1.

4. Removal of Power Transformer

- a. Remove 4 screws (5) in Fig. 1.
- b. Remove 4 screws (6) in Fig. 1.

5. Checking and Parts Replacement of MAIN P.C.B. (1)

- a. Remove 2 plastic rivets (7) in Fig. 1.
- b. Remove 12 screws (8) in Fig. 1, then remove the MAIN P.C.B. (1) with Heat Sink.

(分解は番号順に行ってください。)
電源コードを抜いてください。

1. トップカバーの外し方

- ①のネジ6本を外す。(Fig. 1)

2. フロントパネルの外し方

- a. ②のネジ6本を外す。(Fig. 1)

3. サブシャーシの外し方

- a. ③のプラスチックリベット4本を外し、サイドプレートを取り外す。
- b. ④のネジ5本を外す。(Fig. 1)

4. 電源トランスの外し方

- a. ⑤のネジ4本を外す。(Fig. 1)
- b. ⑥のネジ4本を外す。(Fig. 1)

5. MAIN P.C.B. (1)のチェックと部品交換

- a. ⑦のプラスチックリベット2本を外す。(Fig. 1)
- b. ⑧のネジ12本を外し、ヒートシンクと共にMAIN P.C.B. (1)を取り外す。

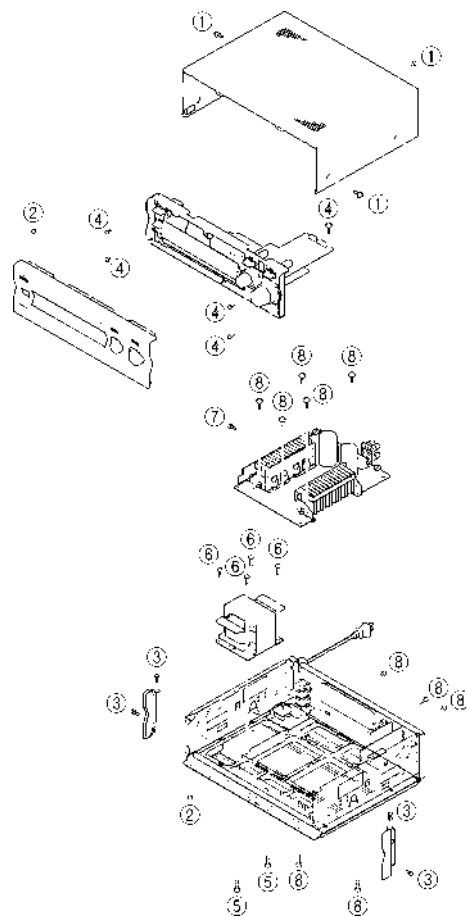

Fig. 1

ADJUSTMENTS

Confirmation of Idling Current

- Right after Power is switched ON, confirm the voltages measured at R111, R135 (L ch) and R112, R136 (R ch) are between 0.4mV to 8.0mV.
- If it exceeds 8.0mV, open (cut off) R175 (L ch), R176 (R ch) and reconfirm the voltage.

アイドル電流の確認

- 電源投入直後、R111/R135(L ch)、R112/R136(R ch)の端子間の電圧を測定し、0.4mVから8.0mVの間であることを確認してください。
- 電圧が8.0mVを超えている場合は、次のようにします。
R111/R135(L ch)の場合、R175をカット
R112/R136(R ch)の場合、R176をカット

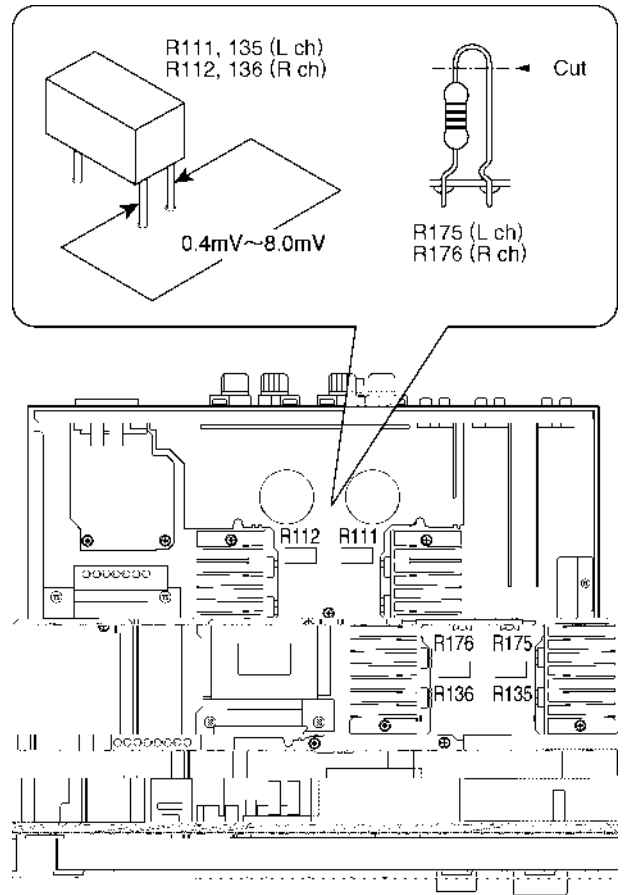

BLOCK DIAGRAM

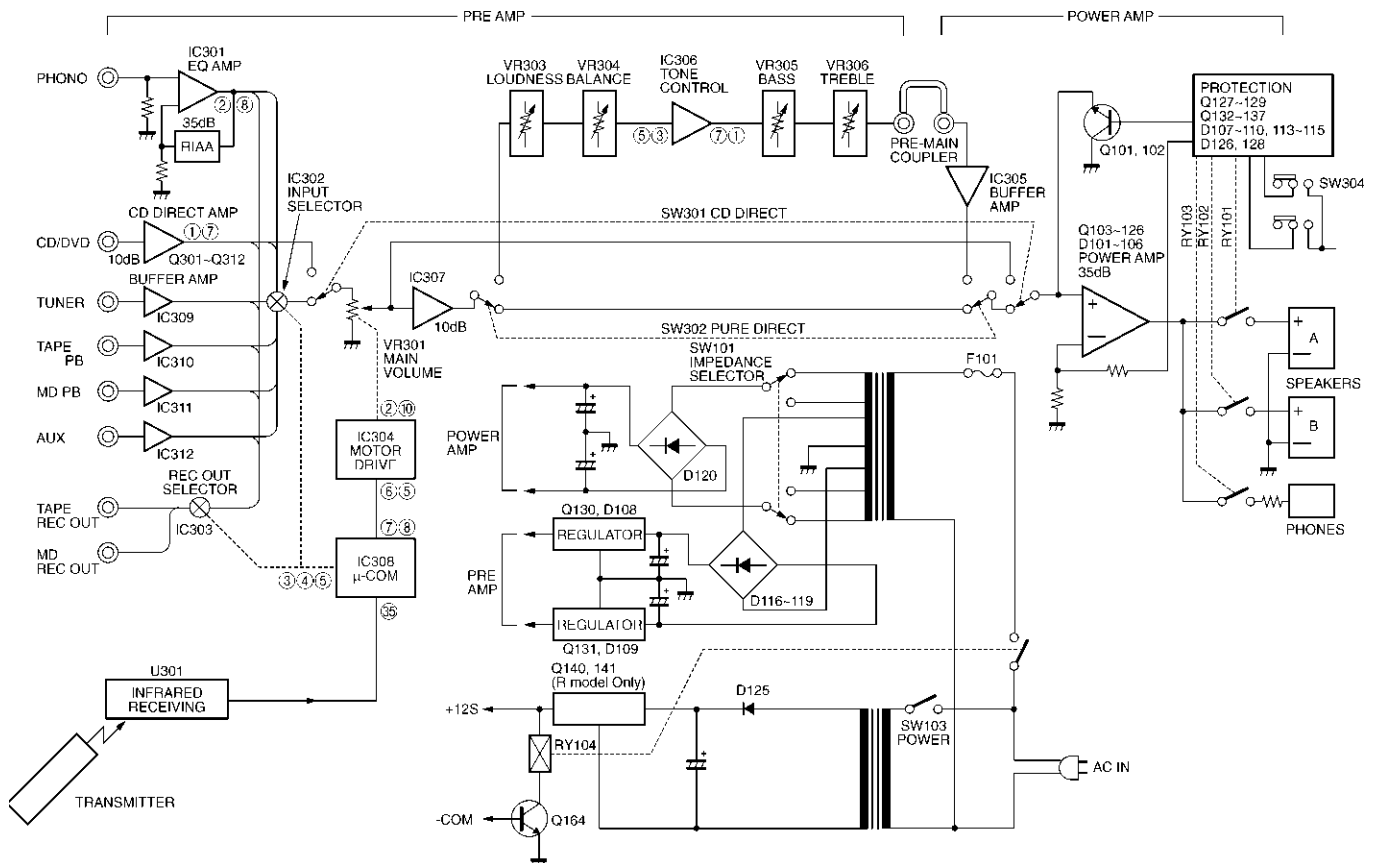

μ-COM DATA

IC308 : M34748E8SP

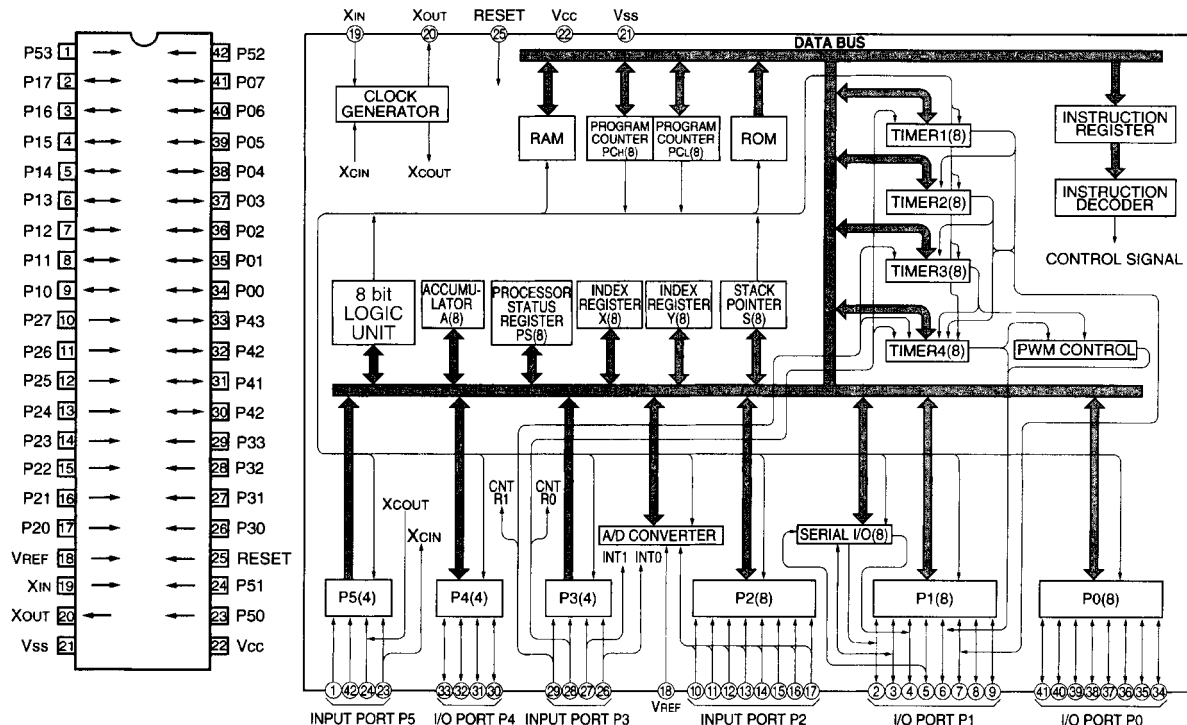

No.	Port	I/O	Form	RE	Function	
1	P53	I	I			
2	P17	I/O	O	CEI	Chip Enable (input selector)	
3	P16	I/O	O	CK	Clock	S-CLK
4	P15	I/O	O	DATA	Data	T x D
5	P14	I/O	O			
6	P13	I/O	O	TMO	Tape Monitor	
7	P12	I/O	O	VRUP	Motor Volume (UP)	
8	P11	I/O	O	VRDN	Motor Volume (DOWN)	
9	P10	I/O	O	RYPN	Power Relay	
10	P27	I	I	ENR	Rotary Encoder (Right)	
11	P26	I	I	ENL	Rotary Encoder (Left)	
12	P25	I	I	D34/5	AX-496, 396/596 Detect	H: 496, 396 L: 596
13	P24	I	I			
14	P23	I	I	REC	Rec Out Selector Detect	IN3
15	P22	I	I	PRDC	Protection (DC)	IN2
16	P21	I	I	PRI	Protection (Overload)	IN1
17	P20	I	I	PRPS	Protection (Power Supply)	IN0
18	Vref	I		VREF		
19	Xin	I		XIN		
20	Xout	O		XOUT		
21	Vss			VSS		
22	Vcc			VCC		
23	P50	I	I	PRINH	Release the Protection	
24	P61	I/O	O			
25	/RESET	I		/RESET		
26	P30	I	I	PD	Power Down Detect	INT0
27	P31	I	I	REM	Remote Control	INT1
28	P32	I	I	D43	AX-493/393 Detect	
29	P33	I	I	TPM	Tape Monitor	
30	P40	I/O	O	LEDTM	LED (Tape Monitor)	
31	P41	I/O	O	MUTE	Mute	
32	P42	I/O	O	RYSP	Speaker Relay	
33	P43	I/O	O	LSBY	LED (Power)	
34	P00	I/O	I	PS	Power	Key On Wakeup
35	P01	I/O	I	REM	Remote Control (Wakeup)	Key On Wakeup
36	P02	I/O	O	LEDP	LED (Phono)	
37	P03	I/O	O	LEDTM	LED (Tuner)	
38	P04	I/O	O	LEDC	LED (CD)	
39	P05	I/O	O	LEDM	LED (Tape)	
40	P06	I/O	O	LEDTP	LED (MD)	
41	P07	I/O	O	LEDA	LED (AUX)	
42	P52	I	I			

PRINTED CIRCUIT BOARD (Foil side)

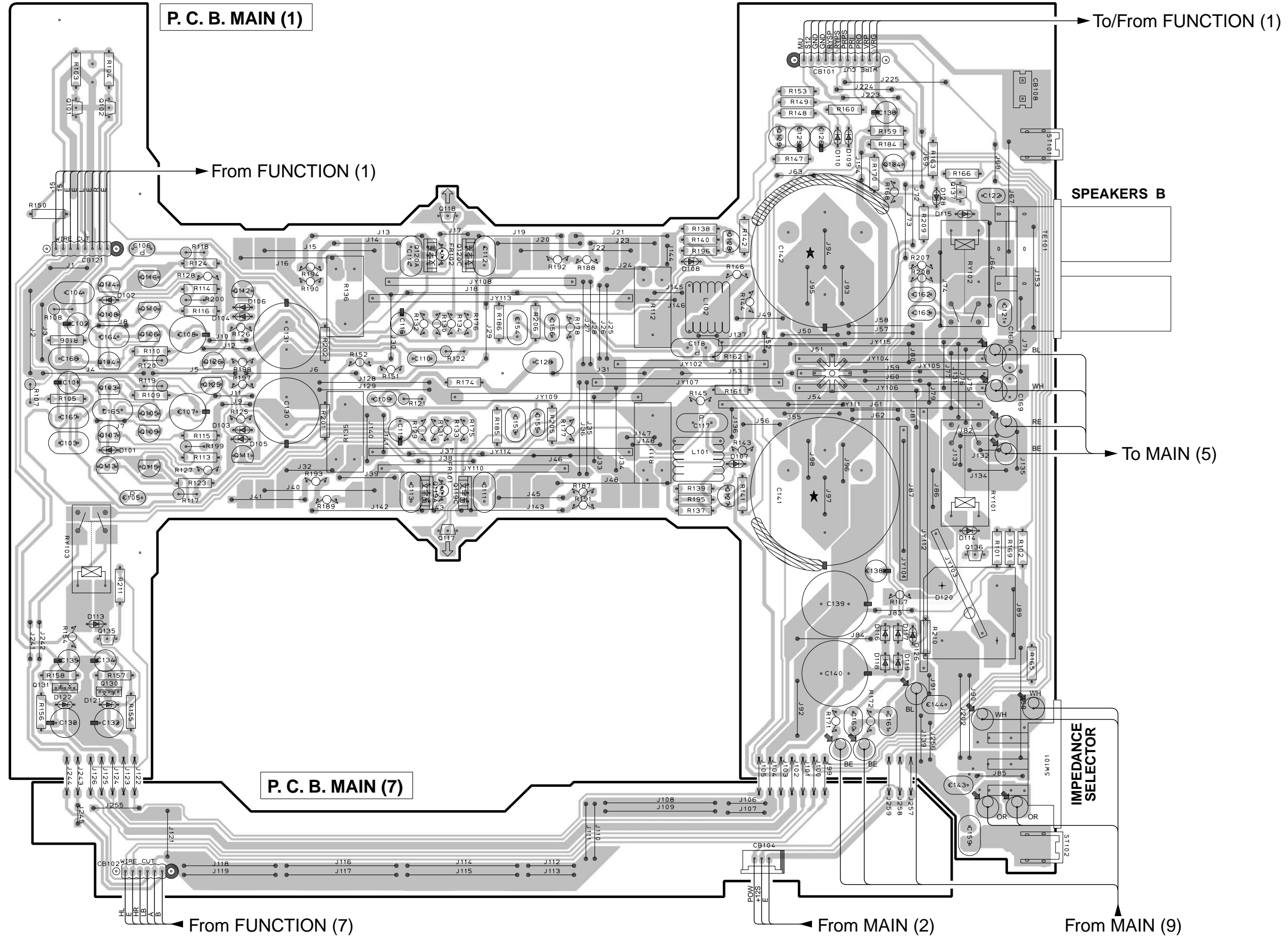

PRINTED CIRCUIT BOARD (Foil side)

P. C. B. MAIN (11)

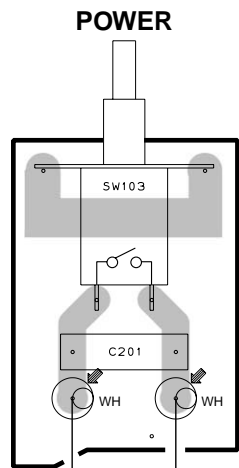

P. C. B. MAIN (2)

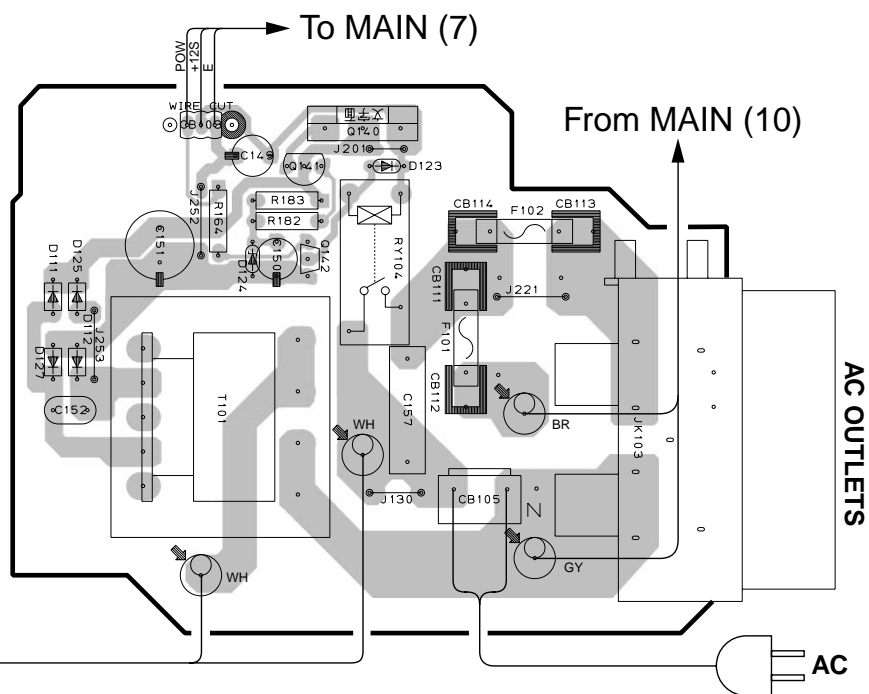

P. C. B. MAIN (5)

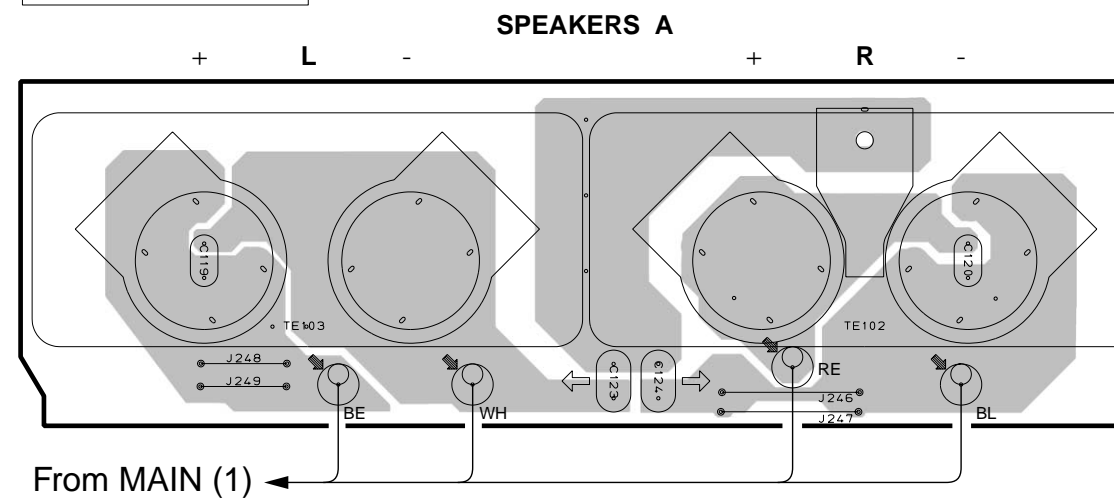

P. C. B. MAIN (4)

(R, T models only)

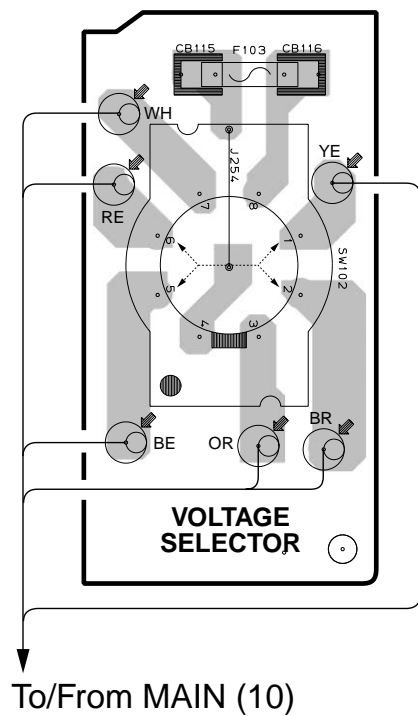

P. C. B. MAIN (9)

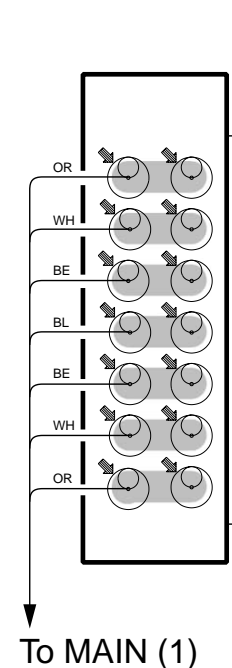

P. C. B. MAIN (10)

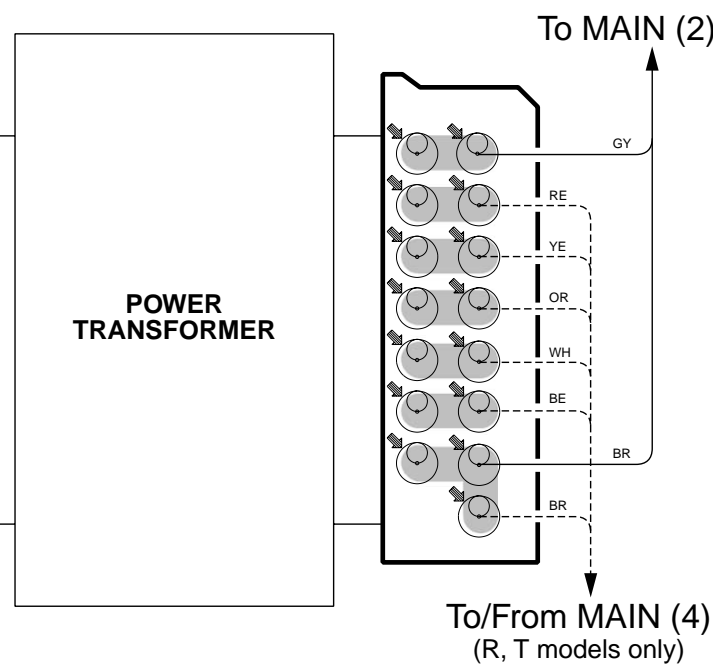

1 ■ PRINTED CIRCUIT BOARD (Foil side)

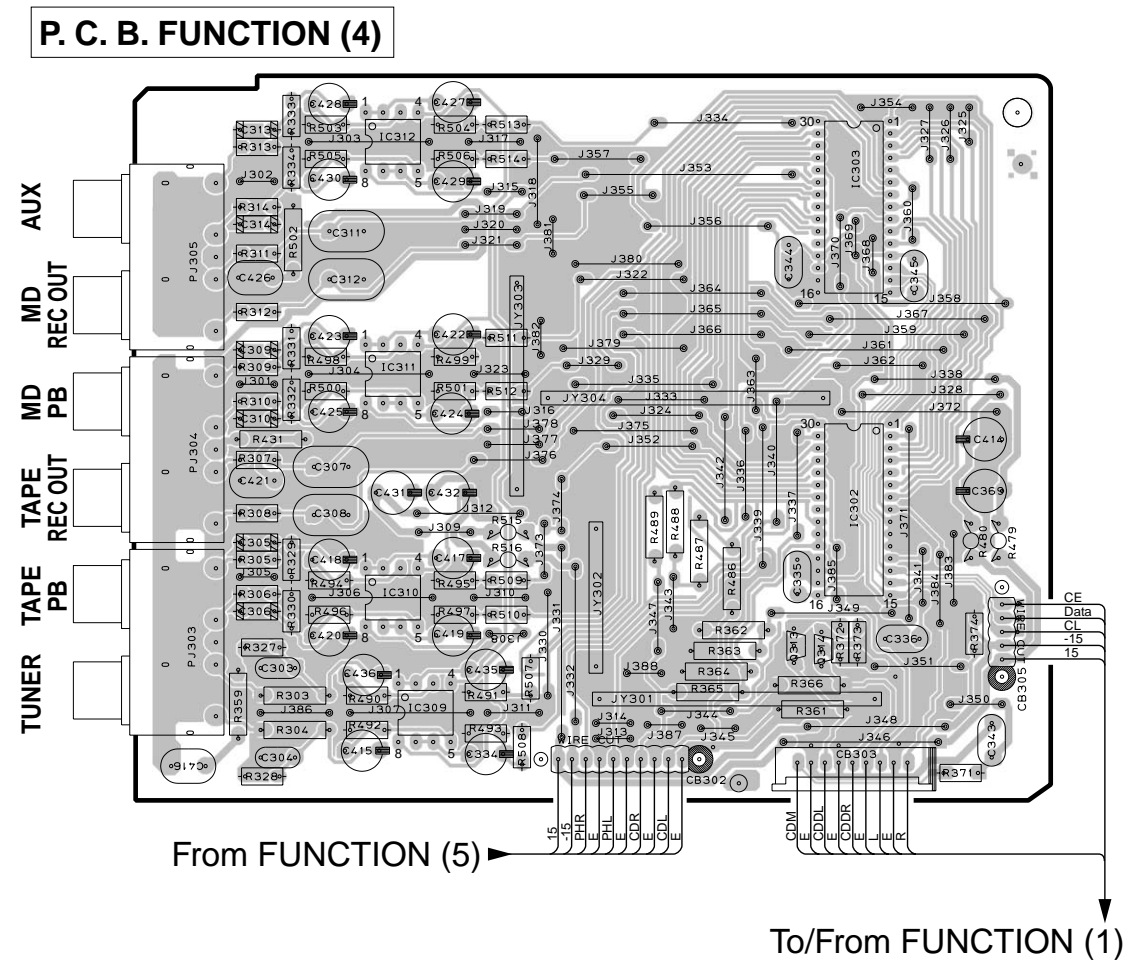
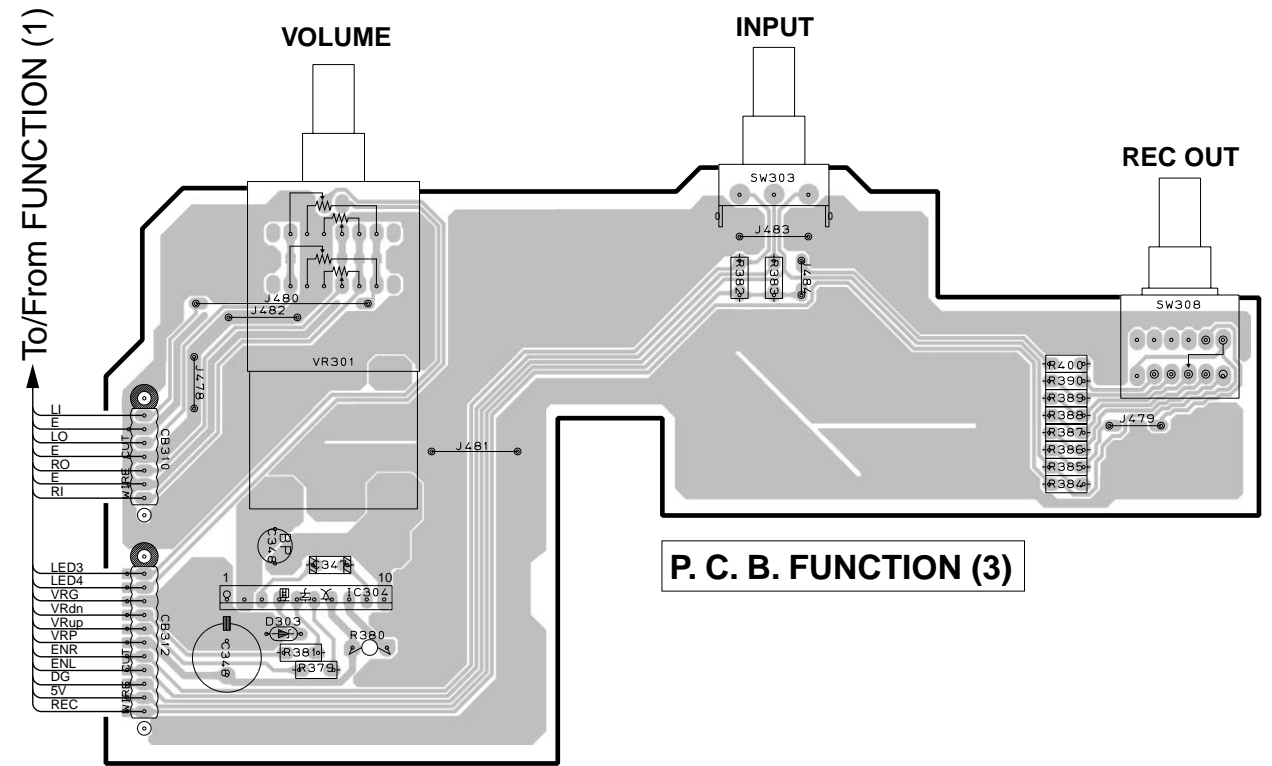
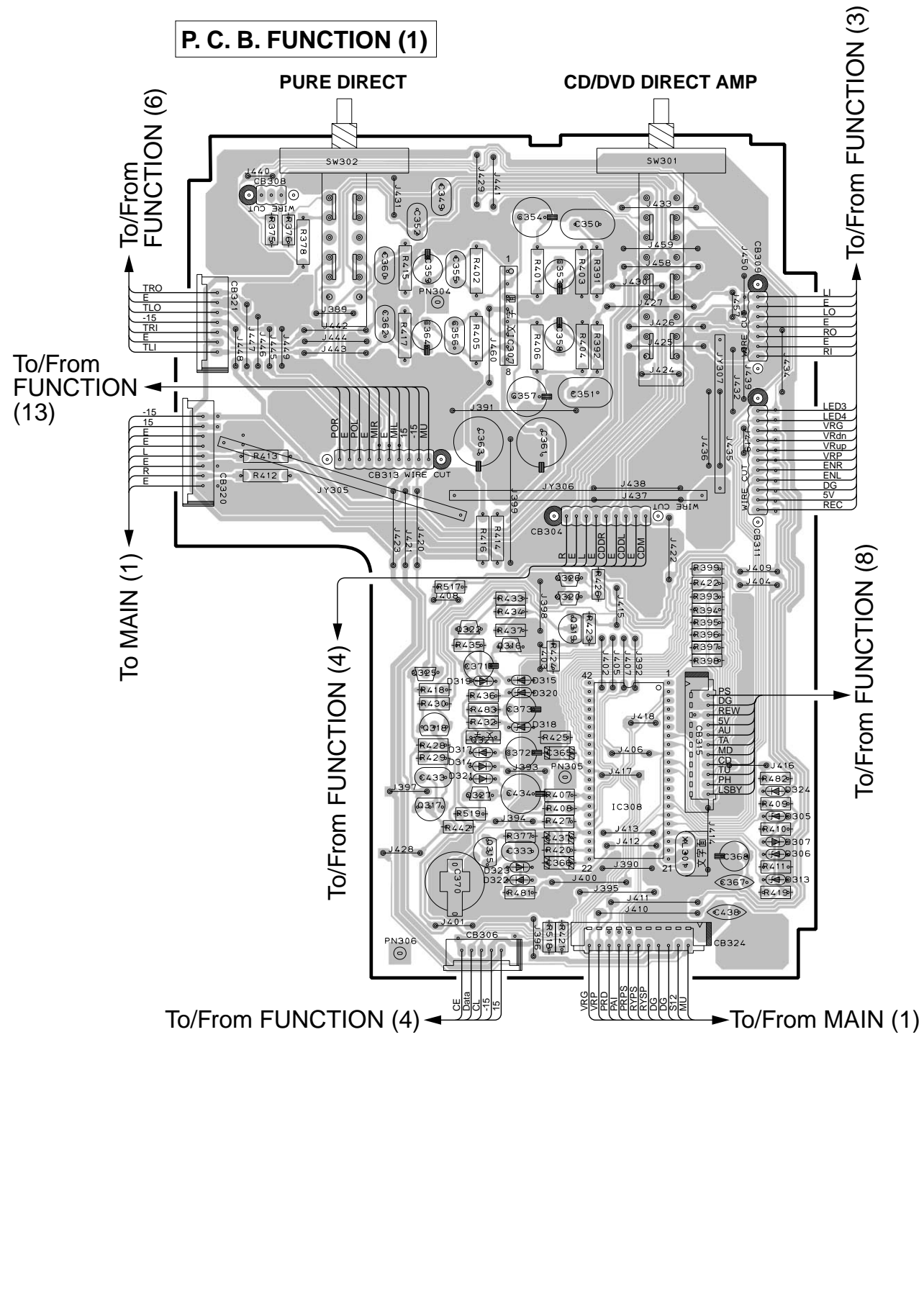

PRINTED CIRCUIT BOARD (Foil side)

P. C. B. FUNCTION (5)

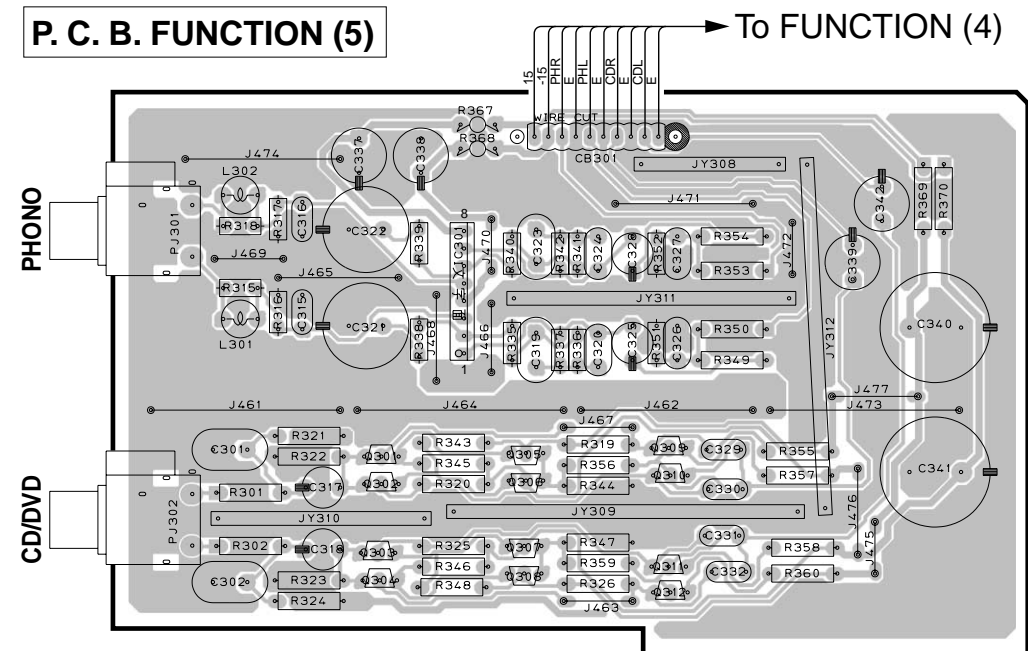

P. C. B. FUNCTION (7)

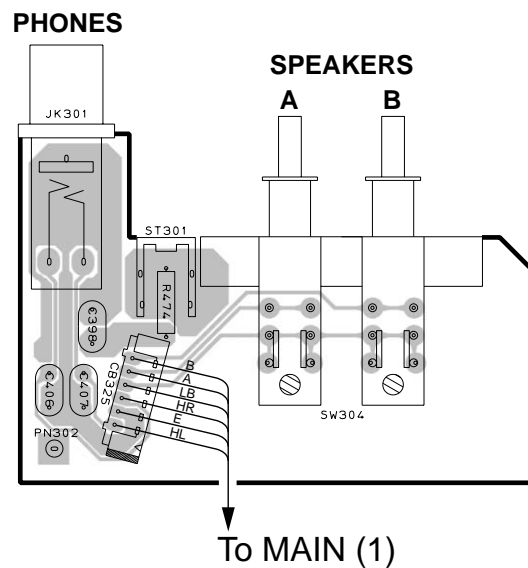

P. C. B. FUNCTION (8)

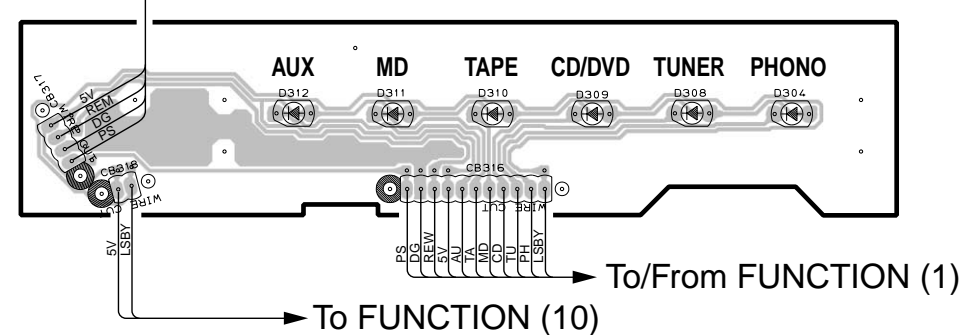

P. C. B. FUNCTION (6)

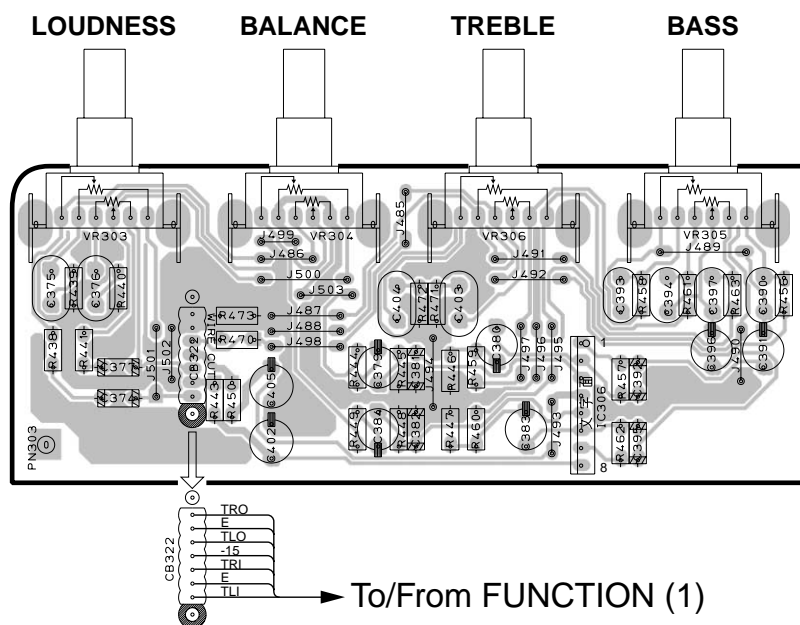

P. C. B. FUNCTION (9)

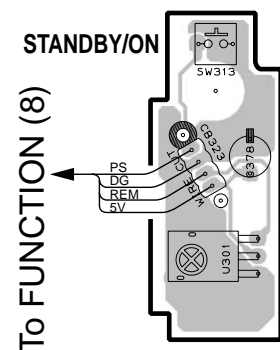

P. C. B. FUNCTION (10)

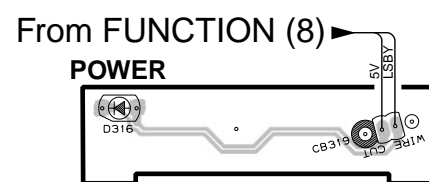

P. C. B. FUNCTION (11)

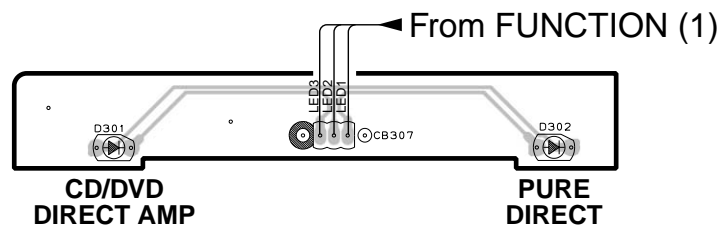

P. C. B. FUNCTION (13)

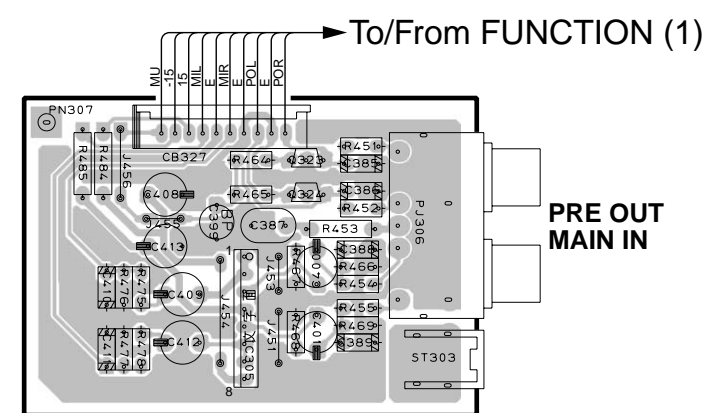

■ SCHEMATIC DIAGRAM

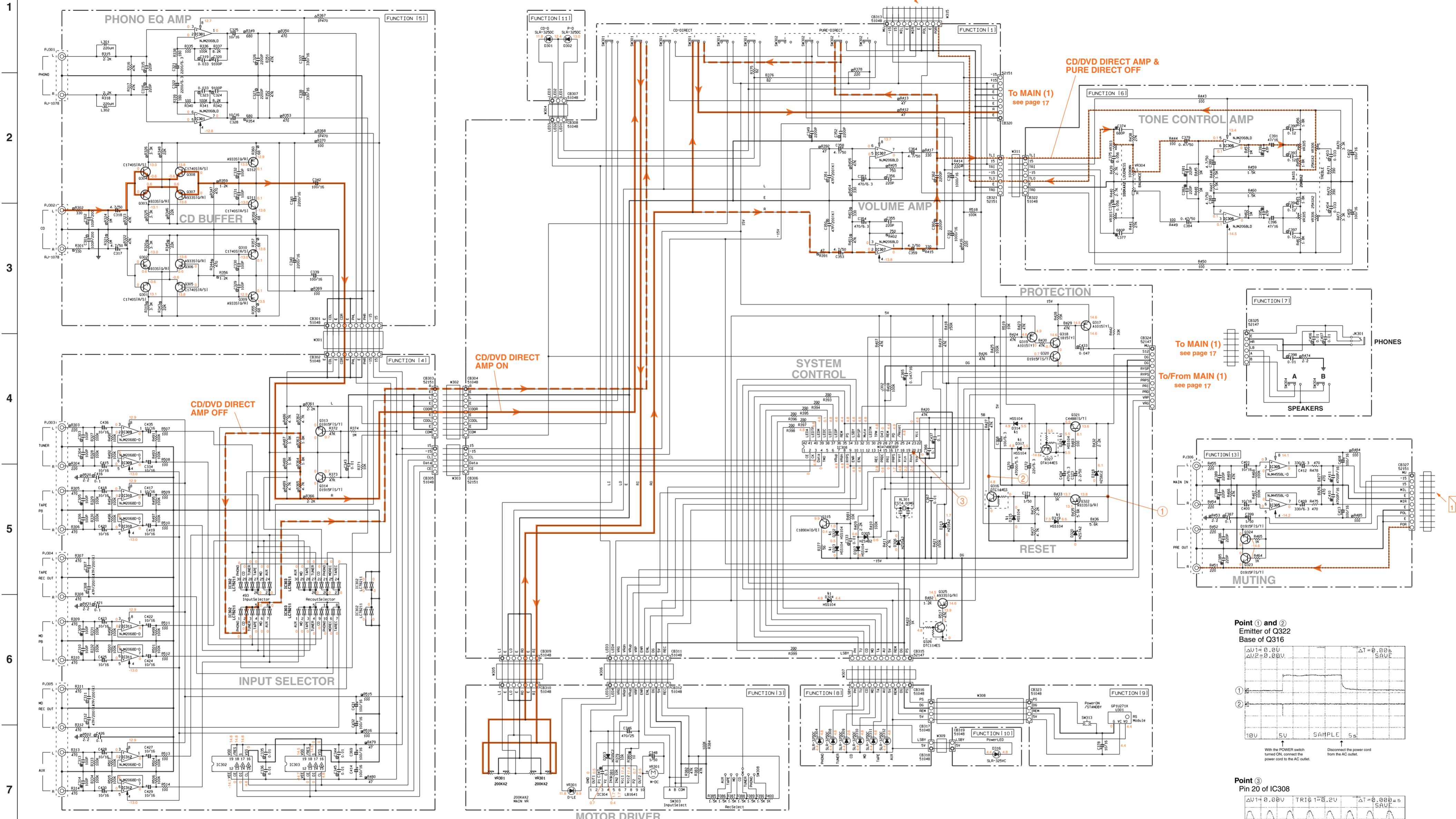

NOTICE (mode1)
 (J)..... JAPANESE
 (U)..... U.S.A
 (C)..... CANADIAN
 (R)..... GENERAL
 (A)..... AUSTRALIAN
 (B)..... BRITISH
 (S)..... EUROPEAN
 (T)..... CHINA
 (L)..... SINGAPORE

REMARKS	PARTS NAME
NO MARK	CARBON FILM RESISTOR (P+5)
△	METAL OXIDE FILM RESISTOR (P-10)
□	METAL OXIDE FILM RESISTOR
▲	METAL FILM RESISTOR
○	METAL PLATE RESISTOR
◇	FIRE PROOF CARBON FILM RESISTOR
◎	CEMENT MOUNTED RESISTOR
⊙	SEMI VARIABLE RESISTOR
■	CHIP RESISTOR

REMARKS	PARTS NAME
NO MARK	ELECTROLYTIC CAPACITOR
⊗	TANTALUM CAPACITOR
NO MARK	CERAMIC CAPACITOR
⊙	CERAMIC TUBULAR CAPACITOR
○	POLYESTER FILM CAPACITOR
○	POLYSTYRENE FILM CAPACITOR
○	MICA CAPACITOR
○	POLYPROPYLENE FILM CAPACITOR
●	SEMICONDUCTIVE CERAMIC CAPACITOR

Interchangeable Parts at Manufacture-Stage

Mark	Reference Parts Number	Parts Name
81	9397-314-315-317-319-321-324	HS104
82		HS133
83		HS176

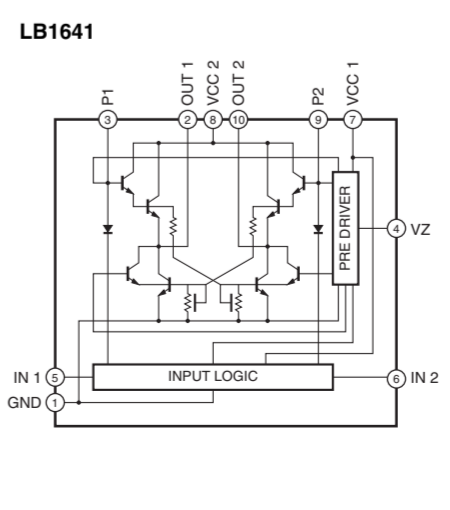
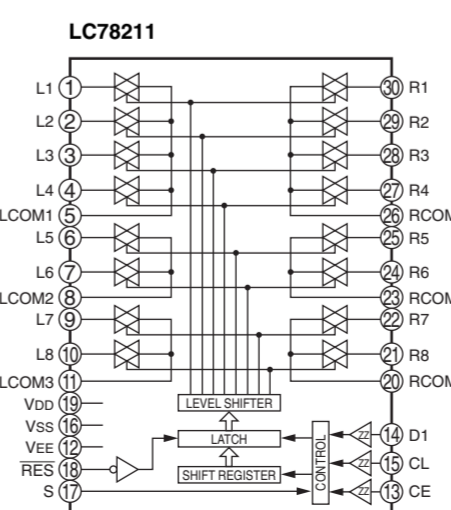
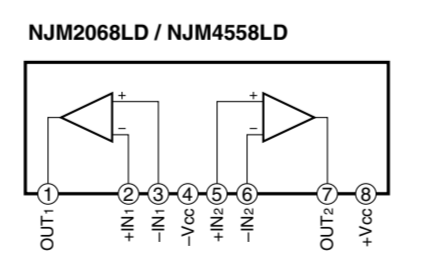

PIN CONNECTION DIAGRAM OF TRANSISTORS, DIODES AND ICs.

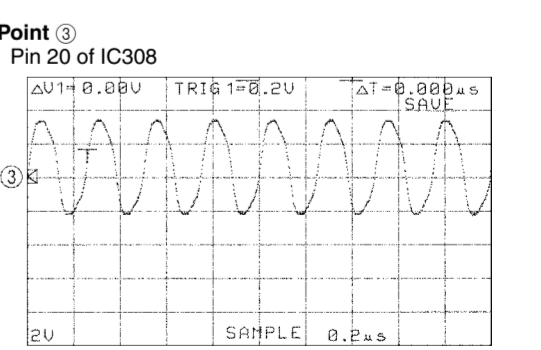
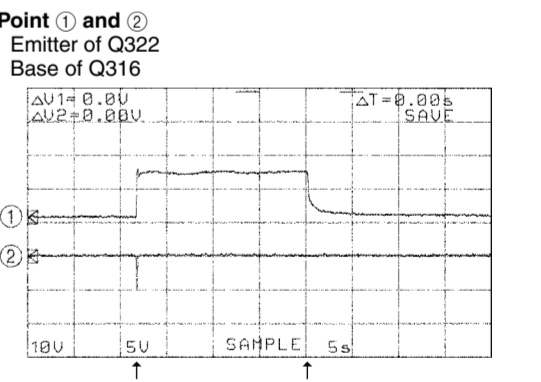
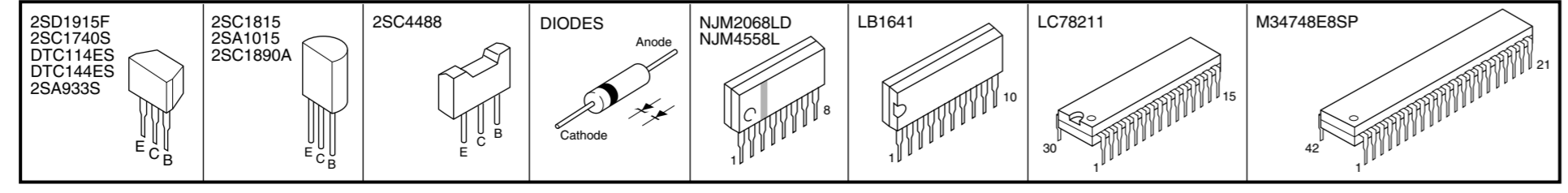

★ All voltage are measured with a 10M Ω DC electric volt meter.
 ★ Components having special characteristics are marked ① and must be replaced with parts having specifications equal to those originally installed.
 ★ Schematic diagram is subject to change without notice.

● 電圧は、内部抵抗10MΩの電圧計で測定したものです。
 ● ①印のある部品は、安全性確保部品を示しています。部品の交換が必要な場合、パーツリストに記載されている部品を使用してください。
 ● 本回路図は標準回路図です。改良のため予告なく変更することがございます。

CAPACITOR	REMARKS	PARTS NAME
NO MARK	NO MARK	ELECTROLYTIC CAPACITOR
⊖	⊖	TANTALUM CAPACITOR
⊕	⊕	CERAMIC CAPACITOR
⊗	⊗	CERAMIC TUBULAR CAPACITOR
⊙	⊙	POLYESTER FILM CAPACITOR
○	○	POLYSTYRENE FILM CAPACITOR
□	□	MICA CAPACITOR
⊙	⊙	POLYPROPYLENE FILM CAPACITOR
●	●	SEMICONDUCTIVE CERAMIC CAPACITOR

REMARKS	PARTS NAME
NO MARK	CARBON FILM RESISTOR (P=5)
□	CARBON FILM RESISTOR (P=10)
△	METAL OXIDE FILM RESISTOR
⊖	METAL FILM RESISTOR
⊕	METAL PLATE RESISTOR
⊗	FIRE-PROOF CARBON FILM RESISTOR
○	CEMENT MOLDED RESISTOR
□	SEMI-VARIABLE RESISTOR
■	TEMP. RESISTOR

NOTICE (model)
(J)..... JAPANESE
(U)..... U.S.A.
(C)..... CANADIAN
(R)..... GENERAL
(A)..... AUSTRALIAN
(B)..... BRITISH
(G)..... EUROPEAN
(T)..... CHINA
(L)..... SINGAPORE

Mark	Reference Parts Number	Parts Name
K1	0101-106-109-110-113-115 123-128	H5104 H5103 H5176
K2	R1104	007-0-110MM R01201-01M-11 H45551
K3	Q142	2SC1740S(B/S) 2SC4601E(F) 2SC3114(L/W/S)

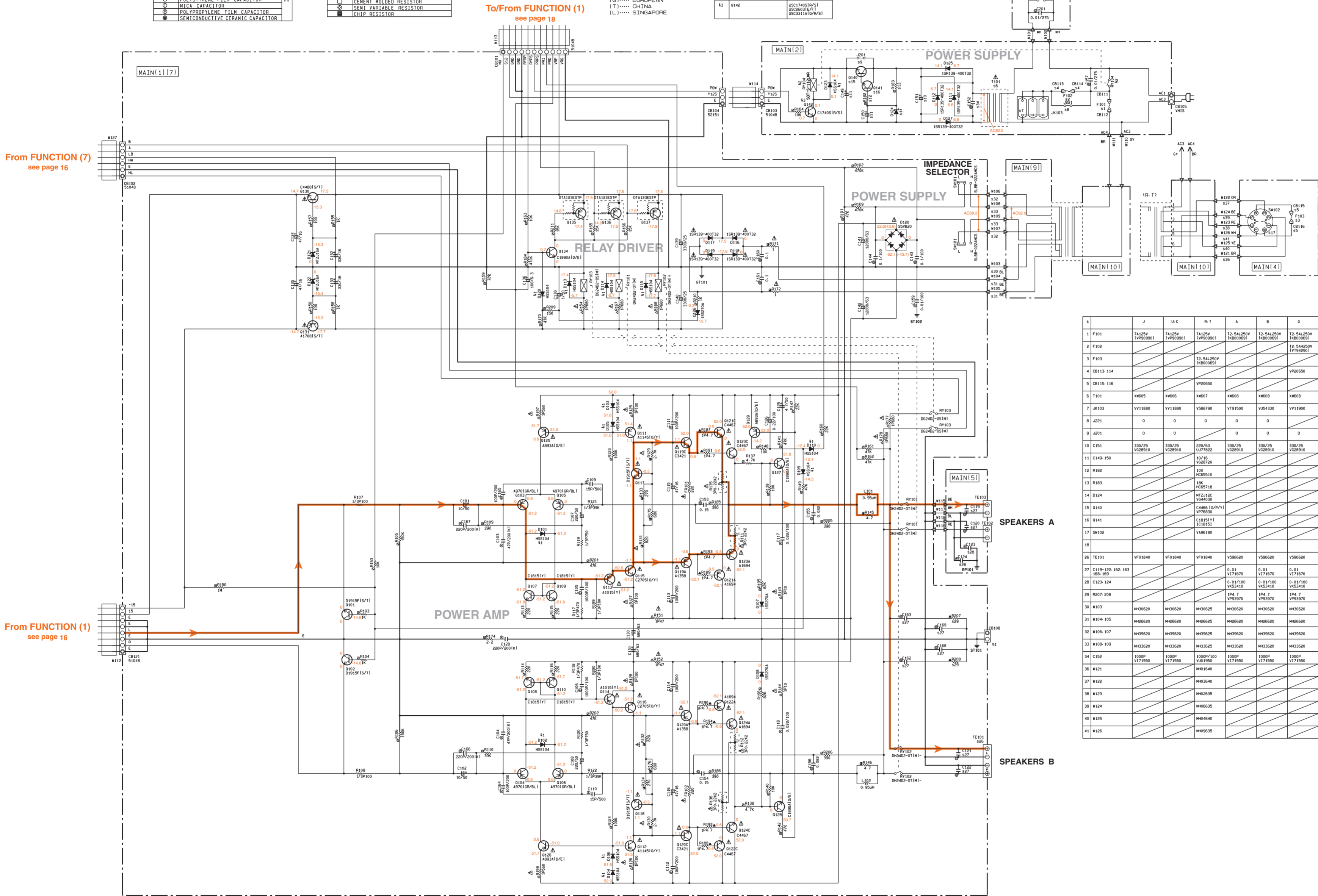

	J	U-C	R-T	A	B	G
1 F101	7A125V VP909901	7A125V VP909901	7A125V VP909901	T2-5AL250V H8000691	T2-5AL250V H8000691	T2-5AL250V H8000691
2 F102						T2-5AL250V H8000691
3 F103						
4 CB113-114						VP20650
5 CB115-116						VP20650
6 T101	XM605	XM606	XM607	XM608	XM609	XM610
7 JK103	VV11880	VV11880	V580790	V7191500	W54330	VV11900
8 J021	0	0	0	0	0	0
9 J011	0	0	0	0	0	0
10 C151	330/25 VC89910	330/25 VC89910	200/10 W27822	330/25 VC89910	330/25 VC89910	330/25 VC89910
11 C149-150			10/16 W28720			
12 R182	100	100	MC65510			
13 R183	100	100	MC65718			
14 D124			MTZJ3C W44235			
15 D140			C446 (10/9/11) VP71830			
16 D141			C18151Y1 TC18151			
17 SW102			VA96180			
18						
26 TE101	VF01840	VF01840	VF01840	Y596620	Y596620	Y596620
27 C119-120-162-163 188-189				0.01 V171670	0.01 V171670	0.01 V171670
28 C123-124				0.01/100 W53410	0.01/100 W53410	0.01/100 W53410
29 R207-208				1P4.7 VP93970	1P4.7 VP93970	1P4.7 VP93970
30 W103	MC30620	MC30620	MC30625	MC30620	MC30620	MC30620
31 W104-105	MC40620	MC40620	MC40625	MC40620	MC40620	MC40620
32 W106-107	MC39620	MC39620	MC39625	MC39620	MC39620	MC39620
33 W108-109	MC33620	MC33620	MC33625	MC33620	MC33620	MC33620
34 C152	1000P V119500	1000P V119500	1000P/100 W119500	1000P V119500	1000P V119500	1000P V119500
36 W121				MC15640		
37 W122				MC20340		
38 W123				MC20335		
39 W124				MC46635		
40 W125				MC46640		
41 W126				MC49635		

PIN CONNECTION DIAGRAM OF TRANSISTORS, DIODES AND ICS.

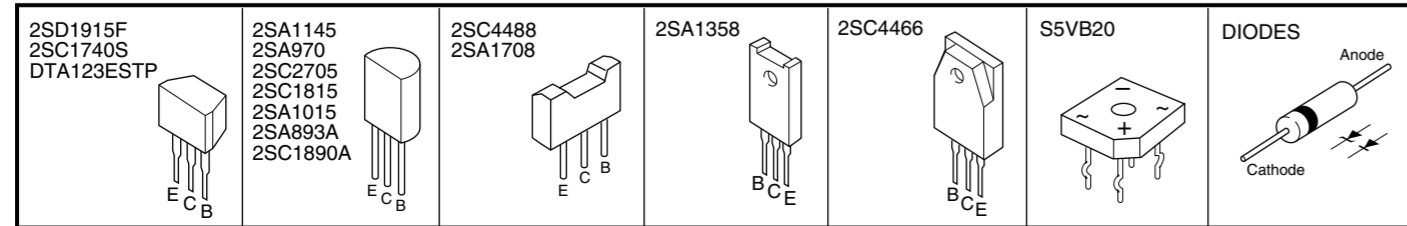

- ★ All voltage are measured with a 10M Ω/DC electric volt meter.
- ★ Components having special characteristics are marked Δ and must be replaced with parts having specifications equal to those originally installed.
- ★ Schematic diagram is subject to change without notice.

- 電圧は、内部抵抗10MΩの電圧計で測定したものです。
- Δ 印のある部品は、安全性確保部品を示しています。部品の交換が必要な場合、パーツリストに記載されている部品を使用してください。
- 本回路図は標準回路図です。改良のため予告なく変更することがございます。

PARTS LIST

■ ELECTRICAL PARTS

■ WARNING

Components having special characteristics are marked \subseteq and must be replaced with parts having specifications equal to those originally installed.

- Carbon resistors (1/6W or 1/4W) are not included in the ELECTRICAL PARTS List. For the parts No. of the carbon resistors, refer to last page.

ABBREVIATIONS IN THIS LIST ARE AS FOLLOWS:

C.A.EL.CHP	: CHIP ALUMI.ELECTROLYTIC CAP	L.EMIT	: LIGHT EMITTING MODULE
C.CE	: CERAMIC CAP	LED.DSPLY	: LED DISPLAY
C.CE.ARRAY	: CERAMIC CAP ARRAY	LED.INFRD	: LED,INFRARED
C.CE.CHP	: CHIP CERAMIC CAP	MODUL.RF	: MODULATOR,RF
C.CE.ML	: MULTILAYER CERAMIC CAP	PHOT.CPL	: PHOTO COUPLER
C.CE.M.CHP	: CHIP MULTILAYER CERAMIC CAP	PHOT.INTR	: PHOTO INTERRUPTER
C.CE.SAFTY	: RECOGNIZED CERAMIC CAP	PHOT.RFLCT	: PHOTO REFLECTOR
C.CE.TUBLR	: CERAMIC TUBULAR CAP	PIN.TEST	: PIN,TEST POINT
C.CE.SMI	: SEMI CONDUCTIVE CERAMIC CAP	PLST.RIVET	: PLASTIC RIVET
C.EL	: ELECTROLYTIC CAP	R.ARRAY	: RESISTOR ARRAY
C.MICA	: MICA CAP	R.CAR.	: CARBON RESISTOR
C.ML.FLM	: MULTILAYER FILM CAP	R.CAR.CHP	: CHIPRESISTOR
C.MP	: METALLIZED PAPER CAP	R.CAR.FP	: FLAME PROOF CARBON RESISTOR
C.MYLAR	: MYLAR FILM CAP	R.FUS	: FUSABLE RESISTOR
C.MYLAR.ML	: MULTILAYER MYLAR FILM CAP	R.MTL.CHP	: CHIP METAL FILM RESISTOR
C.PAPER	: PAPER CAPACITOR	R.MTL.FLM	: METAL FILM RESISTOR
C.PLS	: POLYSTYRENE FILM CAP	R.MTL.OXD	: METAL OXIDE FILM RESISTOR
C.POL	: POLYESTER FILM CAP	R.MTL.PLAT	: METAL PLATE RESISTOR
C.POLY	: POLYETHYLENE FILM CAP	RSNR.CE	: CERAMIC RESONATOR
C.PP	: POLYPROPYLENE FILM CAP	RSNR.CRYS	: CRYSTAL RESONATOR
C.TNTL	: TANTALUM CAP	R.TW.CEM	: TWIN CEMENT FIXED RESISTOR
C.TNTL.CHP	: CHIP TANTALUM CAP	R.WW	: WIRE WOUND RESISTOR
C.TRIM	: TRIMMER CAP	SCR.BND.HD	: BIND HEAD B-TITE SCREW
CN	: CONNECTOR	SCR.BW.HD	: BW HEAD TAPPING SCREW
CN.BS.PIN	: CONNECTOR,BASE PIN	SCR.CUP	: CUP TITE SCREW
CN.CANNON	: CONNECTOR,CANNON	SCR.TERM	: SCREW TERMINAL
CN.DIN	: CONNECTOR,DIN	SCR.TR	: SCREW,TRANSISTOR
CN.FLAT	: CONNECTOR,FLAT CABLE	SUPRT.PCB	: SUPPORT,P.C.B.
CN.POST	: CONNECTOR,BASE POST	SURG.PRTCT	: SURGE PROTECTOR
COIL.MX.AM	: COIL,AM MIX	SW.TACT	: TACT SWITCH
COIL.AT.FM	: COIL,FM ANTENNA	SW.LEAF	: LEAF SWITCH
COIL.DT.FM	: COIL,FM DETECT	SW.LEVER	: LEVER SWITCH
COIL.MX.FM	: COIL,FM MIX	SW.MICRO	: MICRO SWITCH
COIL.OUTPT	: OUTPUT COIL	SW.PUSH	: PUSH SWITCH
DIOD.ARRAY	: DIODE ARRAY	SW.RT.ENC	: ROTARY ENCODER
DIODE.BRG	: DIODE BRIDGE	SW.RT.MTR	: ROTARY SWITCH WITH MOTOR
DIODE.CHP	: CHIP DIODE	SW.RT	: ROTARY SWITCH
DIODE.VAR	: VARACTOR DIODE	SW.SLIDE	: SLIDE SWITCH
DIOD.Z.CHP	: CHIP ZENER DIODE	TERM.SP	: SPEAKER TERMINAL
DIODE.ZENR	: ZENER DIODE	TERM.WRAP	: WRAPPING TERMINAL
DSCR.CE	: CERAMIC DISCRIMINATOR	THRMST.CHP	: CHIP THERMISTOR
FER.BEAD	: FERRITE BEADS	TR.CHP	: CHIP TRANSISTOR
FER.CORE	: FERRITE CORE	TR.DGT	: DIGITAL TRANSISTOR
FET.CHP	: CHIP FET	TR.DGT.CHP	: CHIP DIGITAL TRANSISTOR
FL.DSPLY	: FLUORESCENT DISPLAY	TRANS	: TRANSFORMER
FLTR.CE	: CERAMIC FILTER	TRANS.PULS	: PULSE TRANSFORMER
FLTR.COMB	: COMB FILTER MODULE	TRANS.PWR	: POWER TRANSFORMER ASS'Y
FLTR.LC.RF	: LC FILTER,EMI	TUNER.AM	: TUNER PACK,AM
GND.MTL	: GROUND PLATE	TUNER.FM	: TUNER PACK,FM
GND.TERM	: GROUND TERMINAL	TUNER.PK	: FRONT-ENDTUNER PACK
HOLDER.FUS	: FUSE HOLDER	VR	: ROTARY POTENTIOMETER
IC.PRTCT	: IC PROTECTOR	VR.MTR	: POTENTIOMETER WITH MOTOR
JUMPER.CN	: JUMPER CONNECTOR	VR.SW	: POTENTIOMETER WITH ROTARY SW
JUMPER.TST	: JUMPER,TEST POINT	VR.SLIDE	: SLIDE POTENTIOMETER
L.DTCT	: LIGHT DETECTING MODULE	VR.TRIM	: TRIMMER POTENTIOMETER

Note) Those parts marked with “#” are not included in the P.C.B. ass'y.

Schm Ref.	PART NO.	Description	Rank
*	V5761800	P.C.B.	MAIN(J)
*	V5761900	P.C.B.	MAIN(UC)
*	V5762000	P.C.B.	MAIN(RT)
*	V5762100	P.C.B.	MAIN(A)
*	V5762200	P.C.B.	MAIN(B)
*	V5762300	P.C.B.	MAIN(G)
CB101	Vi878900	CN.BS.PIN	11P
CB102	Vi878400	CN.BS.PIN	6P
CB103	Vi878100	CN.BS.PIN	3P
CB104	VK026200	CN.BS.PIN	3P
CB105	VG879900	CN.BS.PIN	2P
CB108	LA002110	TERM.WRAP	2P
CB111	VP206500	HOLDER.FUS	EYF-52BCT
CB112	VP206500	HOLDER.FUS	EYF-52BCT
CB113	VP206500	HOLDER.FUS	EYF-52BCT(G)
CB114	VP206500	HOLDER.FUS	EYF-52BCT(G)
CB115	VP206500	HOLDER.FUS	EYF-52BCT(RT)
CB116	VP206500	HOLDER.FUS	EYF-52BCT(RT)
CB121	Vi878600	CN.BS.PIN	8P
* C101	VE020200	C.EL	10uF 50V
* C102	VE020200	C.EL	10uF 50V
C103	VK533800	C.PP	47pF 200V
C104	VK533800	C.PP	47pF 200V
* C105	VP917800	C.PP	1000pF 100V
* C106	VP917800	C.PP	1000pF 100V
* C107	VG291400	C.EL	220uF 50V
* C108	VG291400	C.EL	220uF 50V
* C109	FU451150	C.MICA	15pF 500V
* C110	FU451150	C.MICA	15pF 500V
C111	VK533900	C.PP	100pF 200V
C112	VK533900	C.PP	100pF 200V
C113	VK533900	C.PP	100pF 200V
C114	VK533900	C.PP	100pF 200V
* C115	VE017800	C.EL	47uF 25V
* C116	VE017800	C.EL	47uF 25V
C117	VP918300	C.PP	0.022uF 100V
C118	VP918300	C.PP	0.022uF 100V
C119	Vi716700	C.MYLAR	0.01uF 50V(ABG)
C120	Vi716700	C.MYLAR	0.01uF 50V(ABG)
C121	Vi716700	C.MYLAR	0.01uF 50V(ABG)
C122	Vi716700	C.MYLAR	0.01uF 50V(ABG)
C123	VK534100	C.PP	0.01uF 00V(ABG)
C124	VK534100	C.PP	0.01uF 00V(ABG)
C125	VG290800	C.EL	4.7uF 63V
* C126	UJ895220	C.EL	0.22uF 100V
* C128	VK534000	C.PP	220pF 200V
* C130	VP918500	C.EL	680uF 63V
* C131	VP918500	C.EL	680uF 63V
C132	VG287800	C.EL	330uF 16V
C133	VG287800	C.EL	330uF 16V
C134	VG287500	C.EL	47uF 50V
C135	VG287500	C.EL	47uF 50V
C136	VG286200	C.EL	100uF 10V
C138	VG290500	C.EL	1uF 50V
* C139	VG289400	C.EL	3300uF 25V
* C140	VG289400	C.EL	3300uF 25V
* C141	VK574600	C.EL	12000uF 63V
* C142	VK574600	C.EL	12000uF 63V
C143	VT898000	C.MYLAR	0.1uF 100V
C144	VT898000	C.MYLAR	0.1uF 100V
C149	VG287200	C.EL	10uF 50V(RT)
C150	VG287200	C.EL	10uF 50V(RT)
C151	UJ778220	C.EL	220uF 63V(RT)

* New Parts

Schm Ref.	PART NO.	Description	Rank
* C151	VG289100	C.EL	330uF (UCABJG)
C152	Vi715500	C.MYLAR	1000pF (UCABJG)
C152	VU019500	C.MYLAR	1000pF 100V(RT)
* C153	VK398900	C.MYLAR.ML	0.15uF 50V
* C154	VK398900	C.MYLAR.ML	0.15uF 50V
* C155	VZ001900	C.MYLAR	0.082uF 50V
* C156	VZ001900	C.MYLAR	0.082uF 50V
C157	VS741700	C.CE.SAFETY	0.01uF 275V
C159	VK534100	C.PP	0.01uF 100V
* C160	UA355100	C.MYLAR	0.1uF 50V
* C161	UA355100	C.MYLAR	0.1uF 50V
C162	Vi716700	C.MYLAR	0.01uF 50V(ABG)
C163	Vi716700	C.MYLAR	0.01uF 50V(G)
C163	Vi716700	C.MYLAR	0.01uF 50V(ABG)
C164	VK533900	C.PP	100pF 200V
C165	VK533900	C.PP	100pF 200V
C166	VK534000	C.PP	220pF 200V
C167	VK534000	C.PP	220pF 200V
C168	Vi716700	C.MYLAR	0.01uF 50V(ABG)
C169	Vi716700	C.MYLAR	0.01uF 50V(ABG)
C201	VS741700	C.CE.SAFETY	0.01uF 275V
D101	VD631600	DIODE	1SS133,176
D102	VD631600	DIODE	1SS133,176
D103	VD631600	DIODE	1SS133,176
D104	VD631600	DIODE	1SS133,176
D105	VD631600	DIODE	1SS133,176
D106	VD631600	DIODE	1SS133,176
D107	VN008700	DIODE	1SS270A
D108	VN008700	DIODE	1SS270A
D109	VD631600	DIODE	1SS133,176
D110	VD631600	DIODE	1SS133,176
D111	VU264100	DIODE	1SR139-400
D112	VU264100	DIODE	1SR139-400
D113	VD631600	DIODE	1SS133,176
D114	VD631600	DIODE	1SS133,176
D115	VD631600	DIODE	1SS133,176
S D116	VU264100	DIODE	1SR139-400
S D117	VU264100	DIODE	1SR139-400
S D118	VU264100	DIODE	1SR139-400
S D119	VU264100	DIODE	1SR139-400
S D120	VM702000	DIODE.BRG	S5VB20 3.5A 200V
D121	VG441000	DIODE.ZENR	MTZJ16A 16V
D122	VG441000	DIODE.ZENR	MTZJ16A 16V
D123	VD631600	DIODE	1SS133,176
D124	VG440300	DIODE.ZENR	MTZJ12C 12V(RT)
D125	VU264100	DIODE	1SR139-400
D126	VN008700	DIODE	1SS270A
D127	VU264100	DIODE	1SR139-400
D128	VD631600	DIODE	1SS133,176
S F101	KB000690	FUSE	T2.5A 250V(ABG)
* S F101	VP909900	FUSE	T7.0A 125V(JUCRT)
S F102	VT942900	FUSE	TH2.5A 250V(G)
S F103	KB000690	FUSE	T2.5A 250V(RT)
* S FR101	VK188200	R.FUS	220Ω 1/4W
* S FR102	VK188200	R.FUS	220Ω 1/4W
JK103	V4746500	OUTLET.AC	3P(RT)
JK103	VT915000	OUTLET.AC	2P(A)
JK103	VU543300	OUTLET.AC	1P(B)
JK103	VV118800	OUTLET.AC	3P(JUC)
JK103	VV119000	OUTLET.AC	3P(G)
L101	VR906600	COIL	0.95uH
L102	VR906600	COIL	0.95uH
Q101	VK432900	TR	2SD1915F S,T

* New Parts

Schm Ref.	PART NO.	Description	Rank	
Q102	VK432900	TR	2SD1915F S,T	01
Q103	iA097030	TR	2SA970 GR,BL	01
Q104	iA097030	TR	2SA970 GR,BL	01
Q105	iA097030	TR	2SA970 GR,BL	01
Q106	iA097030	TR	2SA970 GR,BL	01
Q107	iC181510	TR	2SC1815 Y	01
Q108	iC181510	TR	2SC1815 Y	01
Q109	iC181510	TR	2SC1815 Y	01
Q110	iC181510	TR	2SC1815 Y	01
S Q111	VE198700	TR	2SA1145 O,Y	01
S Q112	VE198700	TR	2SA1145 O,Y	01
S Q113	iA101510	TR	2SA1015 Y	01
S Q114	iA101510	TR	2SA1015 Y	01
S Q115	VE198800	TR	2SC2705 O,Y	01
S Q116	VE198800	TR	2SC2705 O,Y	01
S Q117	VK432900	TR	2SD1915F S,T	01
S Q118	VK432900	TR	2SD1915F S,T	01
S Q119	iP011600	TR.PAIR	2SA1358/C3421 O,Y	03
S Q120	iP011600	TR.PAIR	2SA1358/C3421 O,Y	03
Q125	VP883000	TR	2SA893A D,E	01
Q126	VP883000	TR	2SA893A D,E	01
Q127	VP883100	TR	2SC1890A D,E	01
Q128	VP883100	TR	2SC1890A D,E	01
Q129	VP883000	TR	2SA893A D,E	01
S Q130	VP872700	TR	2SC4488 S,T	01
S Q131	VP872600	TR	2SA1708 S,T	01
Q134	VP883100	TR	2SC1890A D,E	01
* S Q135	VF325300	TR.DGT	DTA123ESTP	01
* S Q136	VF325300	TR.DGT	DTA123ESTP	01
* Q137	VF325300	TR.DGT	DTA123ESTP	01
Q140	VP768300	TR	2SC4466 O,P,Y(R)	04
Q141	iC181510	TR	2SC1815 Y(RT)	01
Q142	iC174020	TR	2SC1740S R,S	01
S R111	V3873200	R.WW	0.22Ω 3W	
S R112	V3873200	R.WW	0.22Ω 3W	
S R125	VP940400	R.MTL.OXD	100Ω 1W	01
S R126	VP940400	R.MTL.OXD	100Ω 1W	01
S R127	VP940400	R.MTL.OXD	100Ω 1W	01
S R128	VP940400	R.MTL.OXD	100Ω 1W	01
S R129	HV756270	R.CAR.FP	2.7KΩ 1/4W	01
S R130	HV756270	R.CAR.FP	2.7KΩ 1/4W	01
S R131	HV755820	R.CAR.FP	820Ω 1/4W	01
S R132	HV755820	R.CAR.FP	820Ω 1/4W	01
R133	HV755270	R.CAR.FP	270Ω 1/4W	01
R134	HV755270	R.CAR.FP	270Ω 1/4W	01
R135	V3873200	R.WW	0.22Ω 3W	
R136	V3873200	R.WW	0.22Ω 3W	
S R143	VP939800	R.MTL.OXD	10Ω 1W	01
S R144	VP939800	R.MTL.OXD	10Ω 1W	01
R145	HV753470	R.CAR.FP	4.7Ω 1/4W	01
R146	HV753470	R.CAR.FP	4.7Ω 1/4W	01
S R151	VP940200	R.MTL.OXD	47Ω 1W	01
S R152	VP940200	R.MTL.OXD	47Ω 1W	01
S R154	VP941000	R.MTL.OXD	680Ω 1W	01
S R167	VP941000	R.MTL.OXD	680Ω 1W	01
S R168	VP941000	R.MTL.OXD	680Ω 1W	01
S R171	HV753100	R.CAR.FP	1Ω 1/4W	01
S R172	HV753100	R.CAR.FP	1Ω 1/4W	01
R175	HV755680	R.CAR.FP	680Ω 1/4W	01
R176	HV755680	R.CAR.FP	680Ω 1/4W	01
S R177	VP941000	R.MTL.OXD	680Ω 1W	01
S R178	VP941000	R.MTL.OXD	680Ω 1W	01
R187	VP939700	R.MTL.FLM	4.7Ω 1W	01

* New Parts

Schm Ref.	PART NO.	Description	Rank	
R188	VP939700	R.MTL.FLM	4.7Ω 1W	01
R189	VP939700	R.MTL.FLM	4.7Ω 1W	01
R190	VP939700	R.MTL.FLM	4.7Ω 1W	01
R191	VP939700	R.MTL.FLM	4.7Ω 1W	01
R192	VP939700	R.MTL.FLM	4.7Ω 1W	01
R193	VP939700	R.MTL.FLM	4.7Ω 1W	01
R194	VP939700	R.MTL.FLM	4.7Ω 1W	01
S R197	VP940900	R.MTL.OXD	560Ω 1W	
S R198	VP940900	R.MTL.OXD	560Ω 1W	
R207	VP939700	R.MTL.FLM	4.7Ω 1W	01
R207	VP939700	R.MTL.FLM	4.7Ω 1W(ABG)	01
R207	VP939700	R.MTL.FLM	4.7Ω 1W(G)	01
R208	VP939700	R.MTL.FLM	4.7Ω 1W	01
R208	VP939700	R.MTL.FLM	4.7Ω 1W(ABG)	01
R208	VP939700	R.MTL.FLM	4.7Ω 1W(G)	01
* RY101	VY868200	RELAY	DC DH24D2-OT/M-S	07
RY102	VK438300	RELAY	DH24D2-OT/M2	04
RY103	VU566700	RELAY	DG24D2-OS/M	05
RY104	V2712300	RELAY	DC SDT-S-112LMR	05
ST101	BB071360	SCR.TERM	8.3x13	01
ST102	BB071360	SCR.TERM	8.3x13	01
SW101	V4104200	SW.SLIDE	SL13B-022-AMCS	03
SW102	VA961800	VOLT.SELCT	ESE-37247-F(RT)	06
SW103	V4466400	SW.PUSH	SDKLA1-AP1 TV-5	03
S T101	XW605A00	TRANS.PWR	(J)	
* S T101	XW606A00	TRANS.PWR	(UC)	
* S T101	XW607A00	TRANS.PWR	(RT)	
* S T101	XW608A00	TRANS.PWR	(ABG)	
* TE101	V5966200	TERM.SP	LTS0410-1008 (GB)	
TE101	VF018400	TERM.SP	4P (JUCRTA)	04
* TE102	VV247600	TERM.SP	2P	05
* TE103	VV247600	TERM.SP	2P	05
	BB070700	GND.MTL		01
	VY672600	PLATE.GND	SP (ABG)	01
*	V5762400	P.C.B.	FUNCTION	
CB301	Vi878800	CN.BS.PIN	10P	01
CB302	Vi878800	CN.BS.PIN	10P	01
CB303	VK026800	CN.BS.PIN	9P	01
CB304	Vi878700	CN.BS.PIN	9P	01
CB305	Vi878300	CN.BS.PIN	5P	01
CB306	VK026400	CN.BS.PIN	5P	01
CB307	Vi878100	CN.BS.PIN	3P	01
CB308	Vi878100	CN.BS.PIN	3P	01
CB309	Vi878500	CN.BS.PIN	7P	01
CB310	Vi878500	CN.BS.PIN	7P	01
CB311	Vi878900	CN.BS.PIN	11P	01
CB312	Vi878900	CN.BS.PIN	11P	01
CB313	Vi878800	CN.BS.PIN	10P	01
CB315	VK025500	CN.BS.PIN	11P	01
CB316	Vi878900	CN.BS.PIN	11P	01
CB317	Vi878200	CN.BS.PIN	4P	01
CB318	Vi878000	CN.BS.PIN	2P	01
CB319	Vi878000	CN.BS.PIN	2P	01
CB320	VK026700	CN.BS.PIN	8P	01
CB321	VK026600	CN.BS.PIN	7P	01
CB322	Vi878500	CN.BS.PIN	7P	01
CB323	Vi878200	CN.BS.PIN	4P	01
CB324	VK025500	CN.BS.PIN	11P	01
CB325	VF728300	CN	6P	01
* CB327	VK026900	CN	10P	01

* New Parts

Schm Ref.	PART NO.	Description	Rank
C301	VK533900	C.PP 100pF 200V	01
C302	VK533900	C.PP 100pF 200V	01
C303	VQ645600	C.MYLAR 100pF 50V	01
C304	VQ645600	C.MYLAR 100pF 50V	01
C305	VF466800	C.CE.TUBLR 100pF 50V	01
C306	VF466800	C.CE.TUBLR 100pF 50V	01
C307	VK533800	C.PP 47pF 200V	01
C308	VK533800	C.PP 47pF 200V	01
C309	VF466800	C.CE.TUBLR 100pF 50V	01
C310	VF466800	C.CE.TUBLR 100pF 50V	01
C311	VK533800	C.PP 47pF 200V	01
C312	VK533800	C.PP 47pF 200V	01
C313	VF466800	C.CE.TUBLR 100pF 50V	01
C314	VF466800	C.CE.TUBLR 100pF 50V	01
C315	VQ462600	C.MYLAR 220pF 50V	01
C316	VQ462600	C.MYLAR 220pF 50V	01
C317	VE020100	C.EL 4.7uF 100V	01
C318	VE020100	C.EL 4.7uF 100V	01
C319	UA954330	C.MYLAR 0.033uF 50V	01
C320	UA653910	C.MYLAR 9100pF 50V	01
C321	VQ050400	C.EL 2200uF 6.3V	01
C322	VQ050400	C.EL 2200uF 6.3V	01
C323	UA954330	C.MYLAR 0.033uF 50V	01
C324	UA653910	C.MYLAR 9100pF 50V	01
C325	VG287200	C.EL 10uF 50V	01
C326	Vi715900	C.MYLAR 2200pF 50V	01
C327	Vi715900	C.MYLAR 2200pF 50V	01
C328	VG287200	C.EL 10uF 50V	01
C329	VQ645600	C.MYLAR 100pF 50V	01
C330	VQ645600	C.MYLAR 100pF 50V	01
C331	VQ645600	C.MYLAR 100pF 50V	01
C332	VQ645600	C.MYLAR 100pF 50V	01
C333	UA654100	C.MYLAR 0.01uF 50V	01
C334	VG287200	C.EL 10uF 50V	01
C335	UA654100	C.MYLAR 0.01uF 50V	01
C336	UA654100	C.MYLAR 0.01uF 50V	01
C337	VG287800	C.EL 330uF 16V	01
C338	VG287800	C.EL 330uF 16V	01
C339	VQ083100	C.EL 100uF 16V	01
C340	UM049220	C.EL 2200uF 16V	03
C341	UM049220	C.EL 2200uF 16V	03
C342	VQ083100	C.EL 100uF 16V	01
C343	UA654100	C.MYLAR 0.01uF 50V	01
C344	UA654100	C.MYLAR 0.01uF 50V	01
C345	UA654100	C.MYLAR 0.01uF 50V	01
C346	VG289200	C.EL 470uF 25V	01
C347	VJ599100	C.CE.TUBLR 0.1uF 50V	01
C348	UN866100	C.EL 1uF 50V	01
C349	UA953220	C.MYLAR 2200pF 50V	01
C350	VK533800	C.PP 47pF 200V	01
C351	VK533800	C.PP 47pF 200V	01
C352	UA953220	C.MYLAR 2200pF 50V	01
C353	VG290800	C.EL 4.7uF 63V	01
C354	VG286500	C.EL 470uF 10V	01
C355	UA652220	C.MYLAR 220pF 50V	01
C356	UA652220	C.MYLAR 220pF 50V	01
C357	VG286500	C.EL 470uF 10V	01
C358	VG290800	C.EL 4.7uF 63V	01
C359	VG290800	C.EL 4.7uF 63V	01
C360	UA953220	C.MYLAR 2200pF 50V	01
C361	VG288000	C.EL 1000uF 16V	01
C362	UA953220	C.MYLAR 2200pF 50V	01
C363	VG288000	C.EL 1000uF 16V	01

* New Parts

Schm Ref.	PART NO.	Description	Rank
C364	VG290800	C.EL 4.7uF 63V	01
C365	VJ599000	C.CE.TUBLR 0.047uF 16V	01
C366	VJ599100	C.CE.TUBLR 0.1uF 50V	01
C367	FG644100	C.CE 0.01uF 50V	01
C368	VG286200	C.EL 100uF 10V	01
C369	VG287600	C.EL 100uF 25V	01
C370	VU545000	C.EL 47000uF 5.5V	04
C371	VG290500	C.EL 1uF 50V	01
C372	VG286300	C.EL 220uF 10V	01
C373	VG290600	C.EL 2.2uF 50V	01
C374	VG278900	C.CE.TUBLR 680pF 50V	01
C375	UA954560	C.MYLAR 0.056uF 50V	01
C376	UA954560	C.MYLAR 0.056uF 50V	01
C377	VG278900	C.CE.TUBLR 680pF 50V	01
C378	UM397100	C.EL 10uF 16V	01
C379	VG290300	C.EL 0.47uF 50V	01
C380	VG290800	C.EL 4.7uF 63V	01
C381	VG278400	C.CE.TUBLR 220pF 50V	01
C382	VG278400	C.CE.TUBLR 220pF 50V	01
C383	VG290800	C.EL 4.7uF 63V	01
C384	VG290300	C.EL 0.47uF 50V	01
C385	VG278400	C.CE.TUBLR 220pF 50V	01
C386	VG278400	C.CE.TUBLR 220pF 50V	01
C387	UA655100	C.MYLAR 0.1uF 50V	01
C388	VG278400	C.CE.TUBLR 220pF 50V	01
C389	VG278400	C.CE.TUBLR 220pF 50V	01
C390	VE326100	C.MYLAR.ML 0.12uF 50V	01
C391	VG287500	C.EL 47uF 50V	01
C392	VF466700	C.CE.TUBLR 47pF 50V	01
C393	VE326100	C.MYLAR.ML 0.12uF 50V	01
C394	VE326100	C.MYLAR.ML 0.12uF 50V	01
C395	VF466700	C.CE.TUBLR 47pF 50V	01
C396	VG287500	C.EL 47uF 50V	01
C397	VE326100	C.MYLAR.ML 0.12uF 50V	01
C398	Vi716700	C.MYLAR 0.01uF 50V	01
C399	UN866100	C.EL 1uF 50V	01
C400	VG287200	C.EL 10uF 50V	01
C401	VG287200	C.EL 10uF 50V	01
C402	VG287600	C.EL 100uF 25V	01
C403	UA954330	C.MYLAR 0.033uF 50V	01
C404	UA954330	C.MYLAR 0.033uF 50V	01
C405	VG287600	C.EL 100uF 25V	01
C406	UA954100	C.MYLAR 0.01uF 50V	01
C407	UA954100	C.MYLAR 0.01uF 50V	01
C408	VG287600	C.EL 100uF 25V	01
C409	VG286400	C.EL 330uF 6.3V	01
C410	VF467100	C.CE.TUBLR 4700pF 16V	01
C411	VF467100	C.CE.TUBLR 4700pF 16V	01
C412	VG286400	C.EL 330uF 6.3V	01
C413	VG287600	C.EL 100uF 25V	01
C414	VG287600	C.EL 100uF 25V	01
C415	VG287200	C.EL 10uF 50V	01
C416	UA655100	C.MYLAR 0.1uF 50V	01
C417	VG287200	C.EL 10uF 50V	01
C418	VG287200	C.EL 10uF 50V	01
C419	VG287200	C.EL 10uF 50V	01
C420	VG287200	C.EL 10uF 50V	01
C421	UA655100	C.MYLAR 0.1uF 50V	01
C422	VG287200	C.EL 10uF 50V	01
C423	VG287200	C.EL 10uF 50V	01
C424	VG287200	C.EL 10uF 50V	01
C425	VG287200	C.EL 10uF 50V	01
C426	UA655100	C.MYLAR 0.1uF 50V	01

* New Parts

Schm Ref.	PART NO.	Description	Rank
C427	VG287200	C.EL 10uF 50V	01
C428	VG287200	C.EL 10uF 50V	01
C429	VG287200	C.EL 10uF 50V	01
C430	VG287200	C.EL 10uF 50V	01
C431	VG287600	C.EL 100uF 25V	01
C432	VG287600	C.EL 100uF 25V	01
C433	UA954470	C.MYLAR 0.047uF 50V	01
C434	VG286500	C.EL 470uF 10V	01
C435	VG287200	C.EL 10uF 50V	01
C436	VG287200	C.EL 10uF 50V	01
C437	VJ599100	C.CE.TUBLR 0.1uF 50V	01
D301	VR711500	LED(or) SLR-325DC	01
D302	VR711500	LED(or) SLR-325DC	01
D303	VM974200	DIODE.ZENR HZS5C2TD 5.0V	01
D304	VR711500	LED(or) SLR-325DC	01
D305	VM973800	DIODE.ZENR HZS4B2TD 4.0V	01
D306	VM974000	DIODE.ZENR HZS5A2TD 5.0V	01
D307	VD631600	DIODE 1SS133,176	01
D308	VR711500	LED(or) SLR-325DC	01
D309	VR711500	LED(or) SLR-325DC	01
D310	VR711500	LED(or) SLR-325DC	01
D311	VR711500	LED(or) SLR-325DC	01
D312	VR711500	LED(or) SLR-325DC	01
D313	VM974000	DIODE.ZENR HZS5A2TD 5.0V	01
D314	VD631600	DIODE 1SS133,176	01
D315	VD631600	DIODE 1SS133,176	01
D316	VS132300	LED(re) SLR-325VCT31	01
D317	VD631600	DIODE 1SS133,176	01
D318	VM974500	DIODE.ZENR HZS6C2TD 6.0V	01
D319	VD631600	DIODE 1SS133,176	01
D320	VM974600	DIODE.ZENR HZS7A2TD 7.0V	01
D321	VD631600	DIODE 1SS133,176	01
D322	VD631600	DIODE 1SS133,176	01
D323	VD631600	DIODE 1SS133,176	01
D324	VD631600	DIODE 1SS133,176	01
IC301	XM356A00	IC NJM2068LD	02
IC302	XP894A00	IC LC78211	06
IC303	XP894A00	IC LC78211	06
IC304	XF494A00	IC LB1641	03
IC305	XQ212A00	IC NJM4558LD	03
IC306	XM356A00	IC NJM2068LD	02
IC307	XM356A00	IC NJM2068LD	02
* IC308	XY346B00	IC CPU	
IC309	XA987A00	IC NJM2068D-D	01
IC310	XA987A00	IC NJM2068D-D	01
IC311	XA987A00	IC NJM2068D-D	01
IC312	XA987A00	IC NJM2068D-D	01
JK301	V4478300	JACK.PHONE JY-6317Y-03-030	01
L301	VB056900	COIL 220uH	01
L302	VB056900	COIL 220uH	01
PJ301	V5266800	JACK.PIN RJ-1060-10-0541A	
PJ302	V5266800	JACK.PIN RJ-1060-10-0541A	
PJ303	VV551500	JACK.PIN 4P	05
PJ304	VV551500	JACK.PIN 4P	05
PJ305	VV551500	JACK.PIN 4P	05
PJ306	VV551500	JACK.PIN 4P	05
PN301	V3750100	PIN L=50	
PN302	V3750100	PIN L=50	
PN303	V3750100	PIN L=50	
PN304	V3750100	PIN L=50	
PN305	V3750100	PIN L=50	
PN306	V3750100	PIN L=50	
PN307	V3750100	PIN L=50	

* New Parts

Schm Ref.	PART NO.	Description	Rank
Q301	iC174020	TR 2SC1740S R,S	01
Q302	iA093320	TR 2SA933S Q,R	01
Q303	iA093320	TR 2SA933S Q,R	01
Q304	iC174020	TR 2SC1740S R,S	01
Q305	iC174020	TR 2SC1740S R,S	01
Q306	iA093320	TR 2SA933S Q,R	01
Q307	iA093320	TR 2SA933S Q,R	01
Q308	iC174020	TR 2SC1740S R,S	01
Q309	iA093320	TR 2SA933S Q,R	01
Q310	iC174020	TR 2SC1740S R,S	01
Q311	iC174020	TR 2SC1740S R,S	01
Q312	iA093320	TR 2SA933S Q,R	01
Q313	VK432900	TR 2SD1915F S,T	01
Q314	VK432900	TR 2SD1915F S,T	01
Q315	VP883100	TR 2SC1890A D,E	01
Q316	VG722000	TR.DGT DTC144ES	01
Q317	iA101510	TR 2SA1015 Y	01
Q318	iC181510	TR 2SA1815 Y	01
Q319	iA101510	TR 2SA1015 Y	01
Q320	VK432900	TR 2SD1915F S,T	01
Q321	VP872700	TR 2SC4488 S,T	01
Q322	iA093320	TR 2SA933S Q,R	01
Q323	VK432900	TR 2SD1915F S,T	01
Q324	VK432900	TR 2SD1915F S,T	01
Q325	iA093320	TR 2SA933S Q,R	01
Q326	VD678700	TR.DGT DTC114ES	01
Q327	VG721700	TR.DGT DTA144ES	01
R367	VP940800	R.MTL.OXD 470Ω 1W	01
R368	VP940800	R.MTL.OXD 470Ω 1W	01
R380	HV754100	R.CAR.FP 10Ω 1/4W	01
R479	HV754470	R.CAR.FP 47Ω 1/4W	01
R480	HV754470	R.CAR.FP 47Ω 1/4W	01
R515	HV755100	R.CAR.FP 100Ω 1/4W	01
R516	HV755100	R.CAR.FP 100Ω 1/4W	01
ST301	BB071360	SCR.TERM 8.3x13	01
ST303	BB071360	SCR.TERM 8.3x13	01
SW301	VV399800	SW.PUSH SPUN12	05
SW302	VV399900	SW.PUSH SPUN12	05
SW303	V4859200	SW.RT.ENC REB161PHB20	
SW304	VV523900	SW.PUSH PBS-YM-001	03
SW308	V5232400	SW.RT SRBU16X001	
SW313	V2014900	SW.TACT EVQ21304M	01
U301	VU591000	L.DTCT GP1U271X	04
* VR301	V5591600	VR.MTR RK-16814MGL A200K	
VR303	VP700700	VR A100KΩ	02
VR304	VP742000	VR MN100KΩ	02
VR305	VP741800	VR B20KΩ	02
VR306	VP741900	VR G25KΩ	02
XL301	VE906000	RSNR.CE 4MHz	01

* New Parts

EXPLODED VIEW

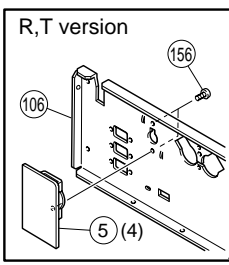
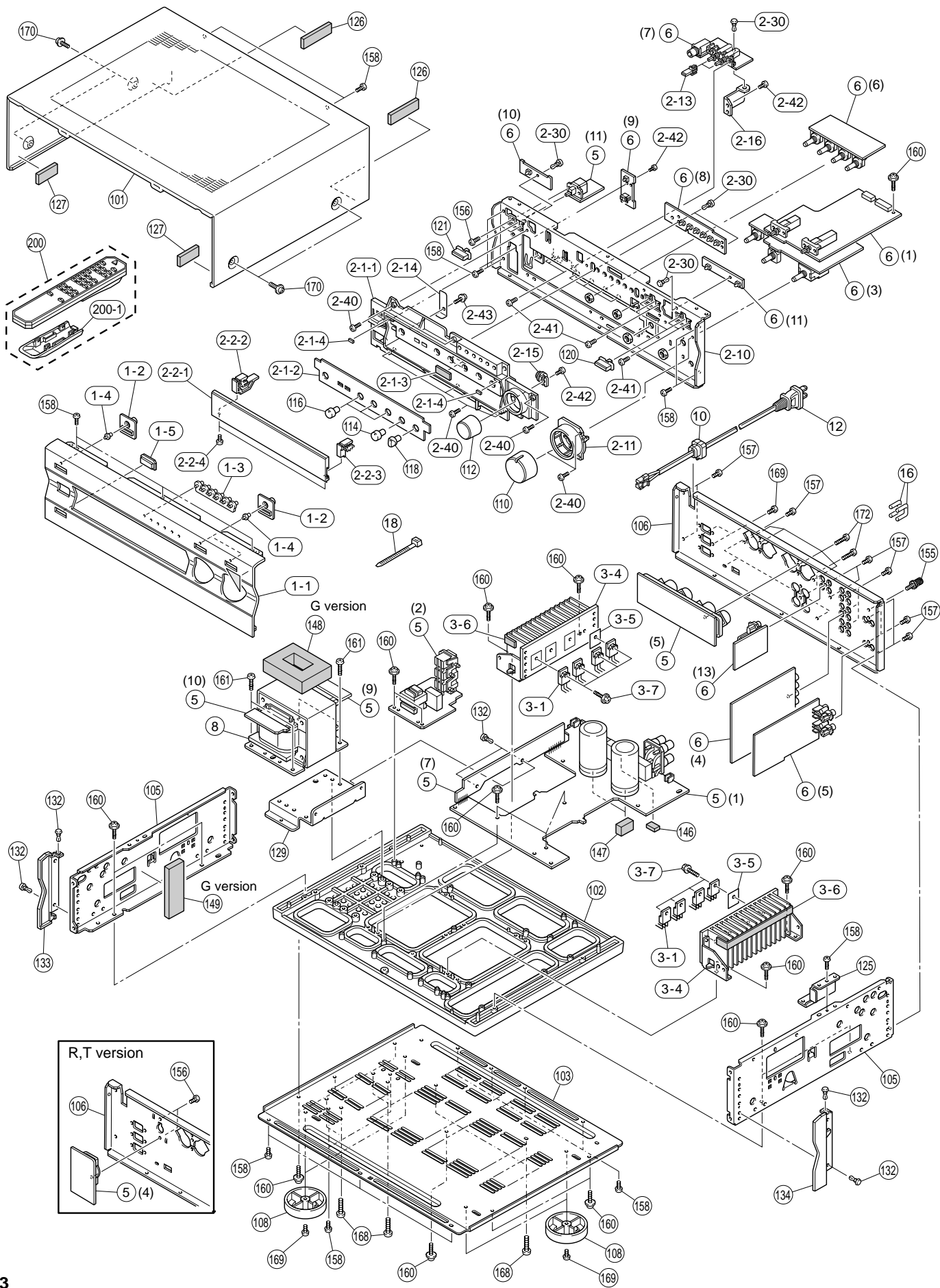

1
2
3
4
5
6
7

MECHANICAL PARTS

Ref. No.	PART NO.	Description	Remarks	Markets	Rank
*	1-1	V5272700	FRONT PANEL	BL	
*	1-1	V5272800	FRONT PANEL	TI	
*	1-1	V5272900	FRONT PANEL	GD	
	1-2	V4598400	ESCUTCHON	BL	
	1-3	V4598800	LENS, 6P		
	1-4	V4598900	LENS, 1P		
	1-5	VV185700	LENS, FILTER		02
*	2-1-1	V4596500	SUB PANEL	BL	
*	2-1-1	V4596600	SUB PANEL	TI	
	2-1-1	V4596700	SUB PANEL	GD	
*	2-1-2	V4598500	PLATE, SP	BL	
*	2-1-2	V4598600	PLATE, SP	TI	
	2-1-2	V4598700	PLATE, SP	GD	
	2-1-3	VY940400	CUSHION, LID		01
	2-1-4	VS699700	DAMPER		01
*	2-2-1	V4596200	PANEL, LID	BL	
*	2-2-1	V4596300	PANEL, LID	TI	
	2-2-1	V4596400	PANEL, LID	GD	
*	2-2-2	V4596800	HINGE, LID L	BL	
*	2-2-2	V4596900	HINGE, LID L	TI	
	2-2-2	V4597000	HINGE, LID L	GD	
*	2-2-3	V4597100	HINGE, LID R	BL	
*	2-2-3	V4597200	HINGE, LID R	TI	
	2-2-3	V4597300	HINGE, LID R	GD	
	2-2-4	VD435300	BIND HEAD P-TITE SCREW	2.6x8 FCRM3-BL	01
*	2-10	V5273000	SUB CHASSIS		
	2-11	V2467900	ESCUTCHEON, VOL	BL	02
	2-11	V2468000	ESCUTCHEON, VOL	TI	02
	2-11	V2468100	ESCUTCHEON, VOL	GD	02
*	2-13	V2918800	BUTTON	3x8	BL
	2-13	V2918900	BUTTON	3x8	TI
	2-13	V4562700	BUTTON	3x8	GD
	2-14	V4593300	SPRING, LID		
	2-15	V2113300	DAMPER, GEAR		04
	2-16	V527450	SUPPORT, PH		
	2-30	VQ368500	PUSH RIVET	P3545-B	01
	2-40	EP600830	BIND HEAD B-TITE SCREW	3x8 FCRM3-BL	01
	2-41	EG330030	BIND HEAD SCREW	3x6 FCRM3-BL	01
	2-42	EP630220	BIND HEAD P-TITE SCREW	3x8 ZMC2-BL	01
	2-43	VT669300	PW HEAD B-TITE SCREW	3x8-8 MFC2	01
* S	3-1	VP768600	PAIR TRANSISTOR	2SA1694/C4467 OP	Q123,Q124
	3-4	VY732600	HEAT SINK ASS'Y		07
	3-5	VV849300	SHEET	19x24	01
	3-6	VP922500	DAMPER	2x10x170	01
	3-7	VK173200	SCREW, TRANSISTOR	3x15 SP FCM3	01
*	5	V5761800	P.C.B. ASS'Y	MAIN	(J)
*	5	V5761900	P.C.B. ASS'Y	MAIN	(UC)
*	5	V5762000	P.C.B. ASS'Y	MAIN	(RT)
*	5	V5762100	P.C.B. ASS'Y	MAIN	(A)
*	5	V5762200	P.C.B. ASS'Y	MAIN	(B)
*	5	V5762300	P.C.B. ASS'Y	MAIN	(G)
*	6	V5762400	P.C.B. ASS'Y	FUNCTION	
* S	8	XT051B00	POWER TRANSFORMER		(J)

* New Parts

Ref. No.	PART NO.	Description	Remarks	Markets	Rank	
* S	8	XT052B00	POWER TRANSFORMER		(U)	
* S	8	XT053B00	POWER TRANSFORMER		(C)	
* S	8	XT055B00	POWER TRANSFORMER		(A)	
* S	8	XT056B00	POWER TRANSFORMER		(G)	
* S	8	XY800A00	POWER TRANSFORMER		(RT)	
	10	V2438700	CORD STOPPER	10P1		02
S	12	V2296800	POWER CORD ASS'Y		(A)	
* S	12	V2363800	POWER CORD ASS'Y		(UC)	
S	12	V4007600	POWER CORD ASS'Y		(J)	05
S	12	VN363700	POWER CORD ASS'Y		(G)	04
S	12	VV437300	POWER CORD ASS'Y		(B)	08
S	12	VZ542500	POWER CORD ASS'Y		(RT)	05
	16	VQ194100	SHORT PLUG	CNT31-0		01
	18	VU590000	BINDING TIE	CBTD001B		01
	101	VV121300	TOP COVER		BL	12
	101	VV121500	TOP COVER		TI	13
	101	VZ884500	TOP COVER		GD	11
	102	VN946400	CHASSIS			11
	103	VV184400	BOTTOM COVER			08
	105	VL664800	FRAME, SIDE			06
*	106	V5273100	REAR PANEL		(U)	
*	106	V5273200	REAR PANEL		(C)	
*	106	V5273300	REAR PANEL		(RT)	
*	106	V5273400	REAR PANEL		(A)	
*	106	V5273500	REAR PANEL		(B)	
*	106	V5273600	REAR PANEL		(G)	
*	106	V5273700	REAR PANEL		(J)	
	108	V0042500	LEG	D60xH21	GD	03
	108	VS025000	LEG	D60xH21	BL,TI	02
*	110	V5375400	KNOB	D40	BL	
*	110	V5375500	KNOB	D40	TI	
*	110	V5375600	KNOB	D40	GD	07
*	112	V5374700	KNOB	D30	BL	
*	112	V5374800	KNOB	D30	TI	
*	112	V5374900	KNOB	D30	GD	06
*	114	V4729300	KNOB, L		BL	
*	114	V4729400	KNOB, L		TI	
	114	V4729500	KNOB, L		GD	03
*	116	V4728700	KNOB, L		BL	
*	116	V4728800	KNOB, L		TI	
	116	V4728900	KNOB, L		GD	03
	118	VT275100	KNOB	D12R	BL	02
	118	VT275200	KNOB	D12R	TI	02
	118	VZ891400	KNOB	D12R	GD	02
*	120	V4598100	BUTTON, 5/22		BL	
*	120	V4598200	BUTTON, 5/22		TI	
	120	V4598300	BUTTON, 5/22		GD	
*	121	V5088600	BUTTON, 5/22 P		BL	
*	121	V5088800	BUTTON, 5/22 P		TI	
	121	V5088900	BUTTON, 5/22 P		GD	
*	125	V5273800	SUPPORT, FBM			
	126	VZ117100	DAMPER, T2	TOP-F		01
*	127	VZ117200	DAMPER, T3	TOP-F		01

* New Parts

Ref. No.	PART NO.	Description	Remarks	Markets	Rank
129	VY732900	FRAME, TR592			04
132	VQ368600	PUSH RIVET	P3555-B		01
* 133	V4597400	PLATE SIDE L		BL	
* 133	V4597500	PLATE SIDE L		TI	
133	V4597600	PLATE SIDE L		GD	
* 134	V4597700	PLATE SIDE R		BL	
* 134	V4597800	PLATE SIDE R		TI	
134	V4597900	PLATE SIDE R		GD	
* 146	VZ117300	DAMPER, T5	PCB		01
* 147	VZ203600	DAMPER, T16	PCB		01
148	VY900000	DAMPER, T21	TRANS	(G)	05
* 149	V6071400	DAMPER	8x30x90	(G)	
155	AA627310	GROUND TERMINAL			01
156	EG330030	BIND HEAD SCREW	3x6 FCRM3-BL		01
157	VN413300	BIND HEAD BONDING B-T. SCREW	3x8 MFZN2-BL		01
158	EP600830	BIND HEAD B-TITE SCREW	3x8 FCRM3-BL		01
160	VB770200	PW HEAD P-TITE SCREW	3x10-8 FCM3		01
* 161	EP600940	BIND HEAD B-TITE SCREW	4x16 FCRM3-BL		01
* 168	VL184400	BIND HEAD B-TITE SCREW	4x22 FCRM3-BL		01
169	EP600250	BIND HEAD B-TITE SCREW	3x8 ZMC2-Y		01
170	21991500	PW HEAD S-TITE SCREW	4x8-10 FCRM3-BL	BL	01
170	VD069600	PW HEAD S-TITE SCREW	4x8-10 MFNI-33	GD	01
170	VH313200	BW HEAD S-TITE SCREW	4x8-10 FNM3-BL	TI	01
172	VY731200	BONDING HEAD TAPPING SCREW	3x10 MFNI33		01
		ACCESSORIES			
200	V4999200	REMOTE CONTROL TRANSMITTER	RC7060-01-0004		07
200-1	AAX13340	LID	BLJYE 60050001		
		BATTERY, MANGANESE	SUM-3,AA,R06		

* New Parts

Parts List for Carbon Resistors

Value	1/4W Type Part No.	1/6W Type Part No.	Value	1/4W Type Part No.	1/6W Type Part No.
1.0 Ω	HJ35 3100	HF85 3100	10 kΩ	HF45 7100	HF45 7100
1.8 Ω	HJ35 3180	*	11 kΩ	HF45 7110	HF45 7110
2.2 Ω	HJ35 3220	HF85 3220	12 kΩ	HJ35 7120	HF85 7120
3.3 Ω	HJ35 3330	HF85 3330	13 kΩ	HF45 7130	HF45 7130
4.7 Ω	HJ35 3470	HF85 3470	15 kΩ	HF45 7150	HF45 7150
5.6 Ω	HJ35 3560	HF85 3560	18 kΩ	HF45 7180	HF45 7180
10 Ω	HF45 4100	HF45 4100	22 kΩ	HF45 7220	HF45 7220
15 Ω	HJ35 4150	HF85 4150	24 kΩ	HF45 7240	HF45 7240
22 Ω	HF45 4220	HF45 4220	27 kΩ	HJ35 7270	HF85 7270
27 Ω	HJ35 4270	HF85 4270	30 kΩ	HF45 7300	HF45 7300
33 Ω	HF45 4330	HF45 4330	33 kΩ	HF45 7330	HF45 7330
39 Ω	HJ35 4470	HF85 4390	36 kΩ	HF45 7360	HF45 7360
47 Ω	HF45 4470	HF45 4470	39 kΩ	HF45 7390	HF45 7390
56 Ω	HF45 4560	HF45 4560	47 kΩ	HF45 7470	HF45 7470
68 Ω	HF45 4680	HF45 4680	51 kΩ	HF45 7510	HF45 7510
75 Ω	HF45 4750	HF45 4750	56 kΩ	HF45 7560	HF45 7560
82 Ω	HF45 4820	HF45 4820	62 kΩ	HF45 7620	HF45 7620
91 Ω	HF45 4910	HF45 4910	68 kΩ	HF45 7680	HF45 7680
100 Ω	HF45 5100	HF45 5100	82 kΩ	HF45 7820	HF45 7820
110 Ω	HJ35 5110	HF85 5110	91 kΩ	HF45 7910	HF45 7910
120 Ω	HF45 5120	HF45 5120	100 kΩ	HF45 8100	HF45 8100
150 Ω	HF45 5150	HF45 5150	110 kΩ	HF45 8110	HF45 8110
160 Ω	HJ35 5160	*	120 kΩ	HF45 8120	HF45 8120
180 Ω	HF45 5180	HF45 5180	150 kΩ	HF45 8150	HF45 8150
200 Ω	HF45 5200	HF45 5200	180 kΩ	HF45 8180	HF45 8180
220 Ω	HF45 5220	HF45 5220	220 kΩ	HJ35 8220	HF85 8220
270 Ω	HF45 5270	HF45 5270	270 kΩ	HF45 8270	HF45 8270
330 Ω	HF45 5330	HF45 5330	300 kΩ	HF45 8300	HF45 8300
390 Ω	HF45 5390	HF45 5390	330 kΩ	HF45 8330	HF45 8330
430 Ω	HF45 5430	HF45 5430	390 kΩ	HJ35 8390	HF85 8390
470 Ω	HF45 5470	HF45 5470	470 kΩ	HF45 8470	HF45 8470
510 Ω	HF45 5510	HF45 5510	560 kΩ	HJ35 8560	HF85 8560
560 Ω	HF45 5560	HF45 5560	680 kΩ	HJ35 8680	HF85 8680
680 Ω	HF45 5680	HF45 5680	820 kΩ	HJ35 8820	HF85 8820
820 Ω	HF45 5820	HF45 5820	1.0 MΩ	HF45 9100	HF45 9100
910 Ω	HF45 5910	HF45 5910	1.2 MΩ	HJ35 9120	*
1.0 kΩ	HF45 6100	HF45 6100	1.5 MΩ	HJ35 9150	HF85 9150
1.2 kΩ	HF45 6120	HF45 6120	1.8 MΩ	HJ35 9180	HF85 9180
1.5 kΩ	HF45 6150	HF45 6150	2.2 MΩ	HJ35 9220	HF85 9220
1.8 kΩ	HF45 6180	HF45 6180	3.3 MΩ	HJ35 9330	HF85 9330
2.0 kΩ	HJ35 6200	HF85 6200	3.9 MΩ	HJ35 9390	*
2.2 kΩ	HF45 6220	HF45 6220	4.7 MΩ	HJ35 9470	HF85 9470
2.4 kΩ	HJ35 6240	HF85 6240			
2.7 kΩ	HF45 6270	HF45 6270			
3.0 kΩ	HF45 6300	HF45 6300			
3.3 kΩ	HF45 6330	HF45 6330			
3.6 kΩ	HJ35 6360	HF85 6360			
3.9 kΩ	HF45 6390	HF45 6390			
4.7 kΩ	HF45 6470	HF45 6470			
5.1 kΩ	HF45 6510	HF45 6510			
5.6 kΩ	HF45 6560	HF45 6560			
6.8 kΩ	HF45 6680	HF45 6680			
8.2 kΩ	HF45 6820	HF45 6820			
9.1 kΩ	HF45 6910	HF45 6910			

1/4W Type

1/6W Type

1 ■ REMOTE CONTROL TRANSMITTER

● SCHEMATIC DIAGRAM

2

3

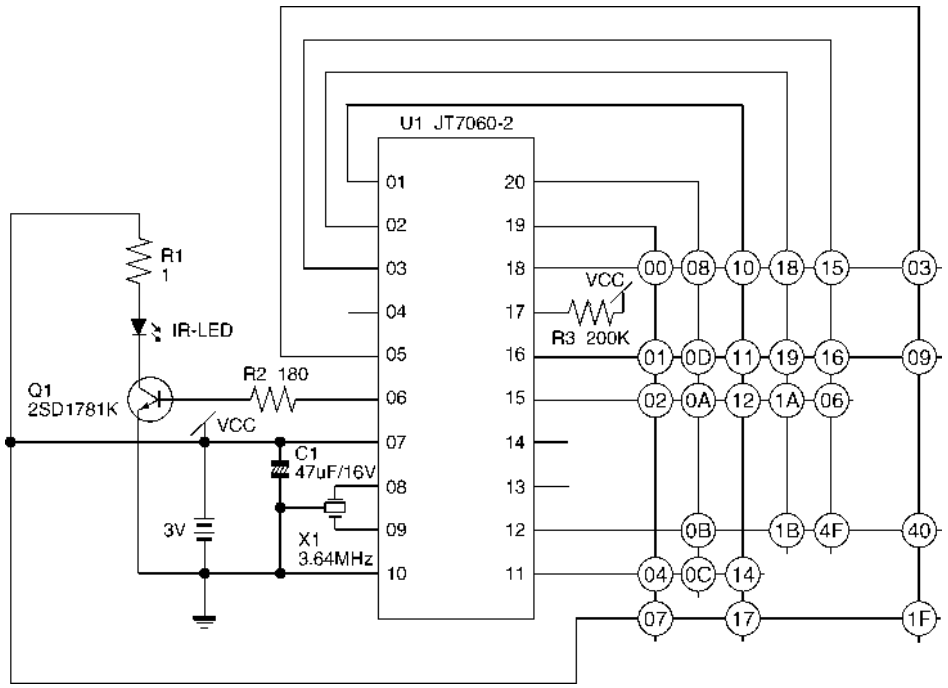

4

5

6

7

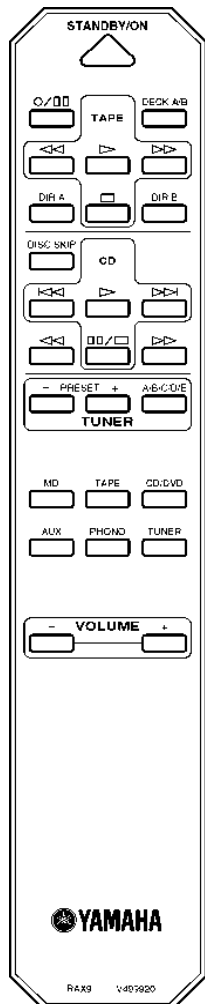

Function	HEX	
	CUSTOM	DATA
PLAY (TAPE) ▷	7A	00
REWIND (TAPE) ◀◀	7A	01
FORWARD (TAPE) ▶▶	7A	02
STOP (TAPE) □	7A	03
REC/PAUSE ◯/□□	7A	04
DECK A/B	7A	06
DIR A	7A	07
PLAY (CD) ▷	7A	08
PAUSE/STOP (CD) □□/□	7A	09
PRESET + (TUNER)	7A	10
PRESET - (TUNER)	7A	11
A/B/C/D/E (TUNER)	7A	12
PHONO	7A	14
CD/DVD	7A	15
TUNER	7A	16
AUX	7A	17
TAPE	7A	18
MD	7A	19
DIR B	7A	40
FORWARD SKIP (CD) ▷▷	7A	0A
BACKWARD SKIP (CD) ◀◀	7A	0B
FORWARD SEARCH (CD) ▷▷	7A	0C
BACKWARD SEARCH (CD) ◀◀	7A	0D
VOLUME +	7A	1A
VOLUME -	7A	1B
STANDBY/ON ◯/	7A	1F
DISC SKIP	7A	4F

AX-596

