

STEREO INTEGRATED AMPLIFIER

AX-750

SERVICE MANUAL

FRONT PANEL

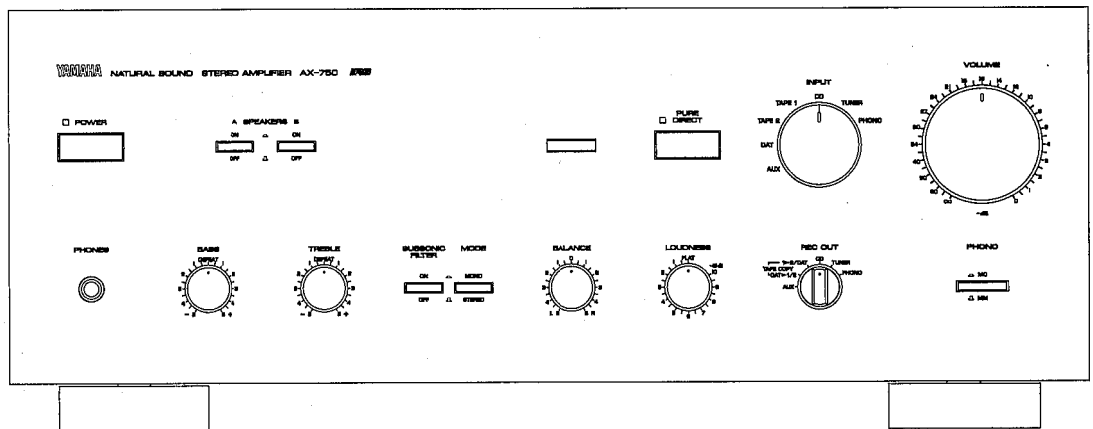
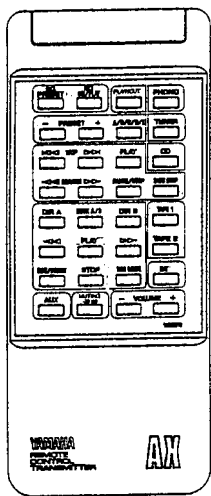

IMPORTANT NOTICE

This manual has been provided for the use of authorized YAMAHA Retailers and their service personnel. It has been assumed that basic service procedures inherent to the industry, and more specifically YAMAHA Products, are already known and understood by the users, and have therefore not been restated.

WARNING: Failure to follow appropriate service and safety procedures when servicing this product may result in personal injury, destruction of expensive components, and failure of the product to perform as specified. For these reasons, we advise all YAMAHA product owners that any service required should be performed by an authorized YAMAHA Retailer or the appointed service representative.

IMPORTANT: The presentation or sale of this manual to any individual or firm does not constitute authorization, certification or recognition of any applicable technical capabilities, or establish a principle-agent relationship of any form.

The data provided is believed to be accurate and applicable to the unit(s) indicated on the cover. The research, engineering, and service departments of YAMAHA are continually striving to improve YAMAHA products. Modifications are, therefore, inevitable and specifications are subject to change without notice or obligation to retrofit. Should any discrepancy appear to exist, please contact the distributor's Service Division.

WARNING: Static discharges can destroy expensive components. Discharge any static electricity your body may have accumulated by grounding yourself to the ground buss in the unit (heavy gauge black wires connect to this buss).

IMPORTANT: Turn the unit OFF during disassembly and part replacement. Recheck all work before you apply power to the unit.

CONTENTS

TO SERVICE PERSONNEL	1
REAR PANELS	1~2
SPECIFICATIONS	3
DIMENSIONS	3
INTERNAL VIEW	4
DISASSEMBLY PROCEDURES	4

ADJUSTMENTS	5
Wiring Diagram	6
Wiring	7
PRINTED CIRCUIT BOARD	8~13
SCHEMATIC DIAGRAM	14,15
PARTS LIST	16~24
REMOTE CONTROL TRANSMITTER	25

TO SERVICE PERSONNEL

1. Critical Components Information.

Components having special characteristics are marked  and must be replaced with parts having specifications equal to those originally installed.

2. Leakage Current Measurement (For 120 V Model Only).

When service has been completed, it is imperative that you verify that all exposed conductive surfaces are properly insulated from supply circuits.

- Meter impedance should be equivalent to 1500 ohm shunted by 0.15 μ F.
- Leakage current must not exceed 0.5 mA.
- Be sure to test for leakage with the AC plug in both polarities.

• POLARIZATION

This product is equipped with a polarized alternating current line plug (a plug having one blade wider than the other). This plug will fit into the power outlet only one way. This is a safety feature. (U.C model only)

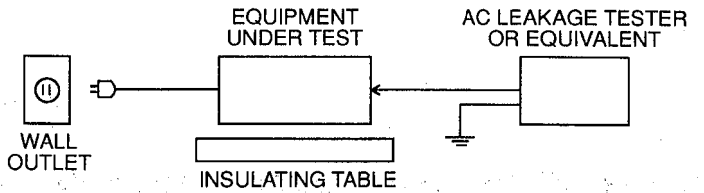

REAR PANELS

● Canadian model

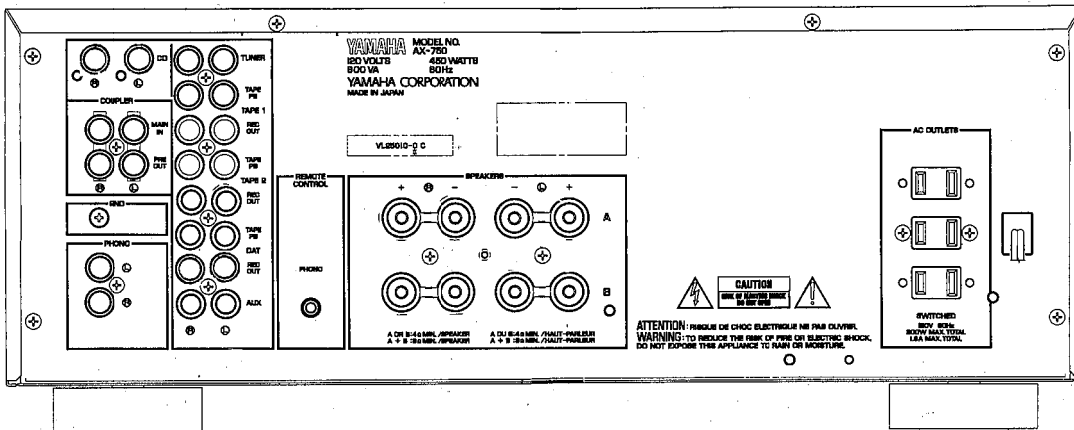

● Australian and British models

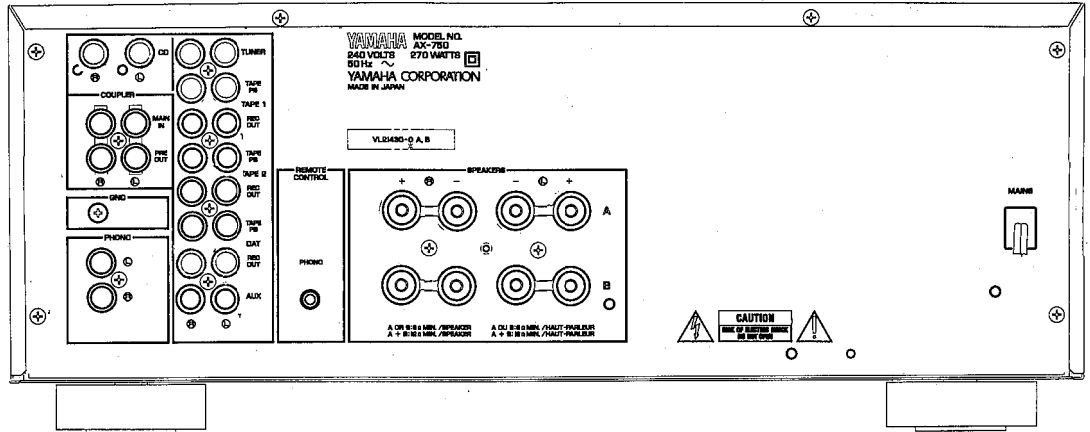

● North European model

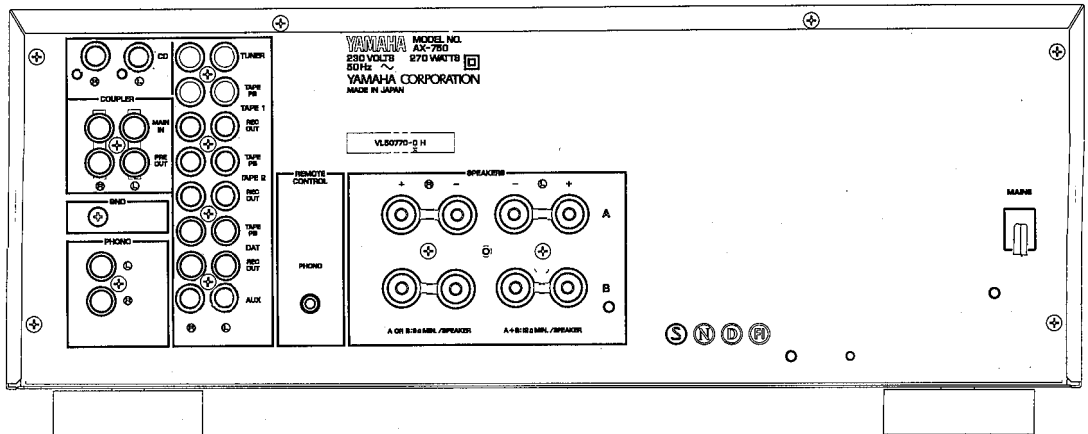

● Germany model

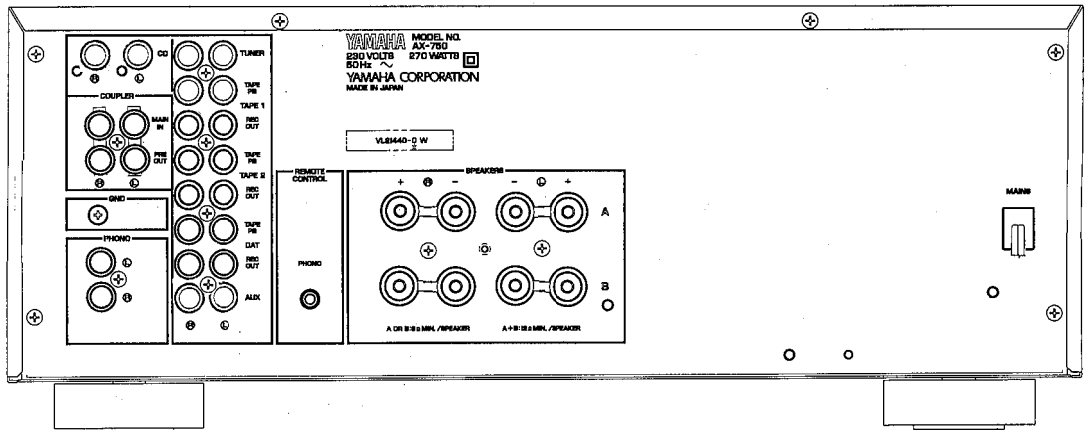

● General model

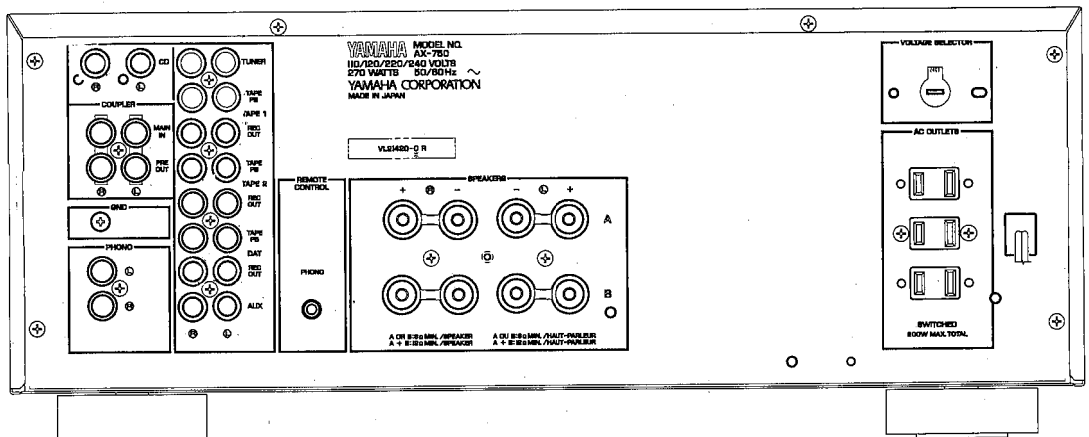

AX-750

SPECIFICATIONS

Minimum RMS Output Power Per Channel
 20 Hz - 20 kHz 0.015% THD 8Ω 110W
 20 Hz - 20 kHz 0.03% THD 6Ω 160W
 Dynamic Power Per Channel
 (by IHF Dynamic Headroom Measuring Method)
 8Ω/6Ω/4Ω/2Ω 150W/200W/230W/260W
 DIN Standard Output Power Per Channel
 (European model)
 1 kHz 0.1% THD 4Ω 185W
 Dynamic Headroom (General model)
 8Ω 1.35 dB
 6Ω 1.97 dB
 IEC Power (European model)
 1 kHz 0.01% THD 8Ω 125W
 Power Bandwidth
 0.03% THD 55W 8Ω 10 Hz - 50 kHz
 Damping Factor
 1 kHz 8Ω 250 or more
 Input Sensitivity/Impedance
 Phono MC 160 μV 220Ω
 MM 2.5 mV/47 kΩ
 CD/TUNER/AUX/TAPE/DAT .. 150 mV/47 kΩ
 MAIN IN 1V/47 kΩ
 Maximum Input level (1 kHz 0.01% THD)
 Phono MC 13.5 mV
 MM 170 mV
 Output Level/Impedance
 REC OUT 150 mV 470Ω
 PRE OUT 1V/1.5kΩ
 Maximum Voltage Output
 20 Hz - 20 kHz 0.01% THD 1.4V
 Headphone Jack Rated Output/Impedance
 0.015% THD RL=8Ω 1.05V/220Ω
 Frequency Response 20Hz - 20kHz
 CD/TUNER/AUX/TAPE/DAT 0±0.5 dB
 MAIN IN 0±0.5 dB
 RIAA Equalization Deviation 20 Hz - 20 kHz,
 Phono MC ±0.5 dB
 MM ±0.3 dB
 Total Harmonic Distortion 20 Hz - 20 kHz
 Phono MC to REC OUT, 3V 0.007%
 MM to REC OUT, 3V 0.003%
 CD/TUNER/AUX/TAPE/DAT to Pre Out, 1V
 0.005%
 CD/TUNER/AUX/TAPE/DAT to Sp Out,
 55W/8Ω 0.008%
 MAIN IN to Sp Out, 55W/8Ω 0.006%
 Intermodulation Distortion
 CD/TUNER/AUX/TAPE/DAT
 Rated Output/8Ω 0.005%
 Signal-to-Noise Ratio (IHF-A Network)
 (Pure Direct Switch: ON)
 Phono MC (500 μV Input Shorted) 75 dB
 MM (5 mV Input Shorted) 92 dB
 CD/AUX/DAT (Shorted) 110 dB
 TUNER/TAPE (Shorted) 106 dB
 Residual Noise (IHF-A Network)
 (Pure Direct Switch: ON) 35 μV
 Channel Separation Vol - 30 dB
 Phono MC, MM Input shorted
 1 kHz/10 kHz 70 dB/55 dB
 CD/TUNER/AUX/TAPE/DAT Input 5.1 kΩ
 Terminated 1 kHz/10 kHz 65 dB/50 dB
 Tone Control Characteristics
 Bass
 Boost / Cut ±10 dB (20 Hz)
 Turnover frequency 350 Hz

Treble
 Boost / Cut ±10 dB (20 kHz)
 Turnover frequency 3.5 kHz
 Filter Characteristics (Subsonic)
 15 Hz, -18 dB/oct
 Continuous Loudness Control
 (Level Related Equalization)
 Attenuation -40dB (1 kHz)
 Audio Muting -20 dB
 Gain Tracking Error (0 - -60 dB) 2 dB
 Power Supply
 U.S.A. and Canadian models
 AC 120V/60 Hz
 British and Australian models
 AC 240V/50 Hz
 European model AC 230V/50 Hz
 General model
 AC 110/120/220/240V, 60/50 Hz
 Power Consumption
 Canada model 450W
 British, Australian, European and General
 models 370W
 AC Outlets
 AC Outlets Switched (3) (Canada and
 General models) 200W max.
 Dimensions (W x H x D) 435 x 171 x 448 mm
 (17-1/8" x 6-3/4" x 17-5/8")
 Weight 13.7 kg
 (30 lbs. 2 oz.)
 Accessories Remote-control transmitter
 Batteries

* Specifications are subject to change without notice.

- C Canadian model
- A Australian model
- H North European model
- B British model
- R General model
- W Germany model

DIMENSIONS

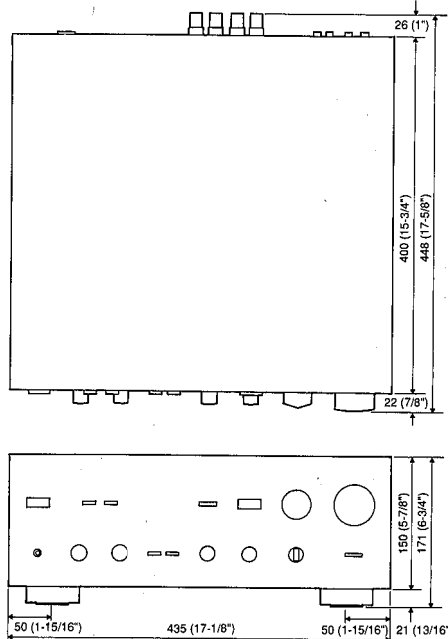

Unit : mm (inch)

INTERNAL VIEW

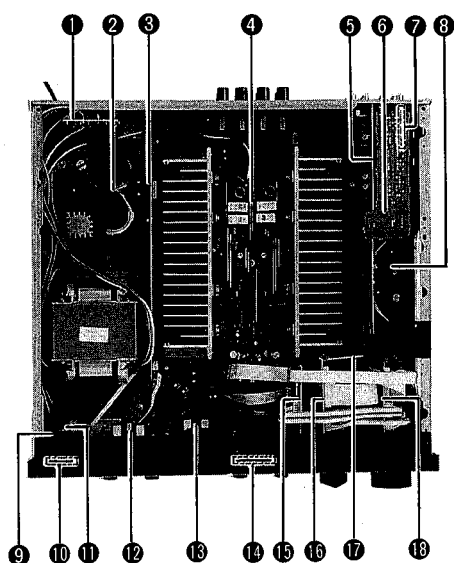

- ① Main circuit board (6) : General model only
- ② Main circuit board (2)
- ③ Main circuit board (3)
- ④ Main circuit board (1)
- ⑤ Function circuit board (1)
- ⑥ Function circuit board (2)
- ⑦ Function circuit board (4)
- ⑧ Function circuit board (3)
- ⑨ Main circuit board (8)
- ⑩ Main circuit board (7)
- ⑪ Function circuit board (6)
- ⑫ Main circuit board (9)
- ⑬ Tone control circuit board (1)
- ⑭ Function circuit board (5)
- ⑮ Main circuit board (4)
- ⑯ Tone control circuit board (2)
- ⑰ Tone control circuit board (3)
- ⑱ Tone control circuit board (4)

DISASSEMBLY PROCEDURES

(Remove parts in disassembly order as numbered)

1. Removal of Top Cover

Remove 7 screws (①, ②, ③) in Fig. 1, and slide the Top Cover back.

2. Removal of Front Panel

Remove 6 screws (④, ⑤) in Fig. 1, and pull the Front Panel forward.

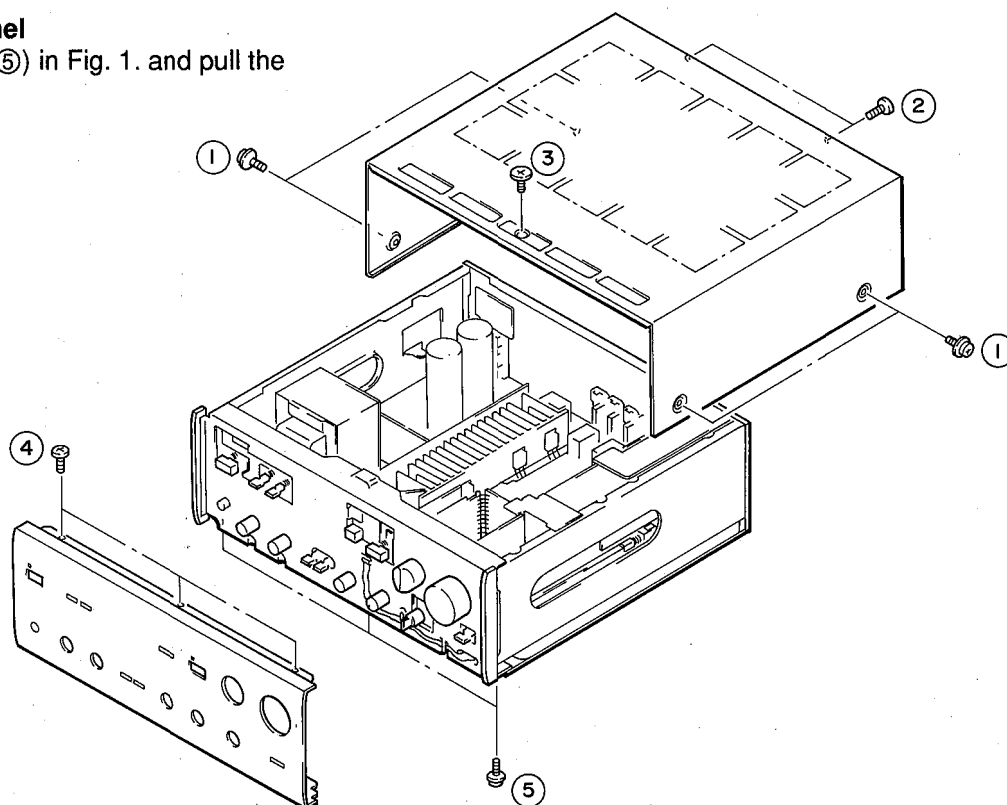

ADJUSTMENTS

1. Before Adjustment

- Make sure that AC line voltage is within:

Model	AC line voltage
C	120 V ± 10%
W,H	230 V ± 10%
A, B	240 V ± 10%

2. Instruments required

- DCVM

● IDLING CURRENT ADJUSTMENT

- When replacing the power and drive transistors, adjust idling current.
- After the power has been turned on, age about 10 minutes in non loaded condition.
- Adjust VR601 (Lch) and VR602 (Rch) so that the voltage across the terminals of R135 and R136 comes to 10mV±4mV DC.

	Test Points	Adjustment Points	Rating
Lch	Across the terminals of R683 or R684 (TP1 ↔ TP2 or TP1 ↔ TP3)	VR601	10 mV±4 mV DC
Rch	Across the terminals of R697 or R698 (TP1 ↔ TP2 or TP1 ↔ TP3)	VR602	10 mV±4 mV DC

● TEST POINT

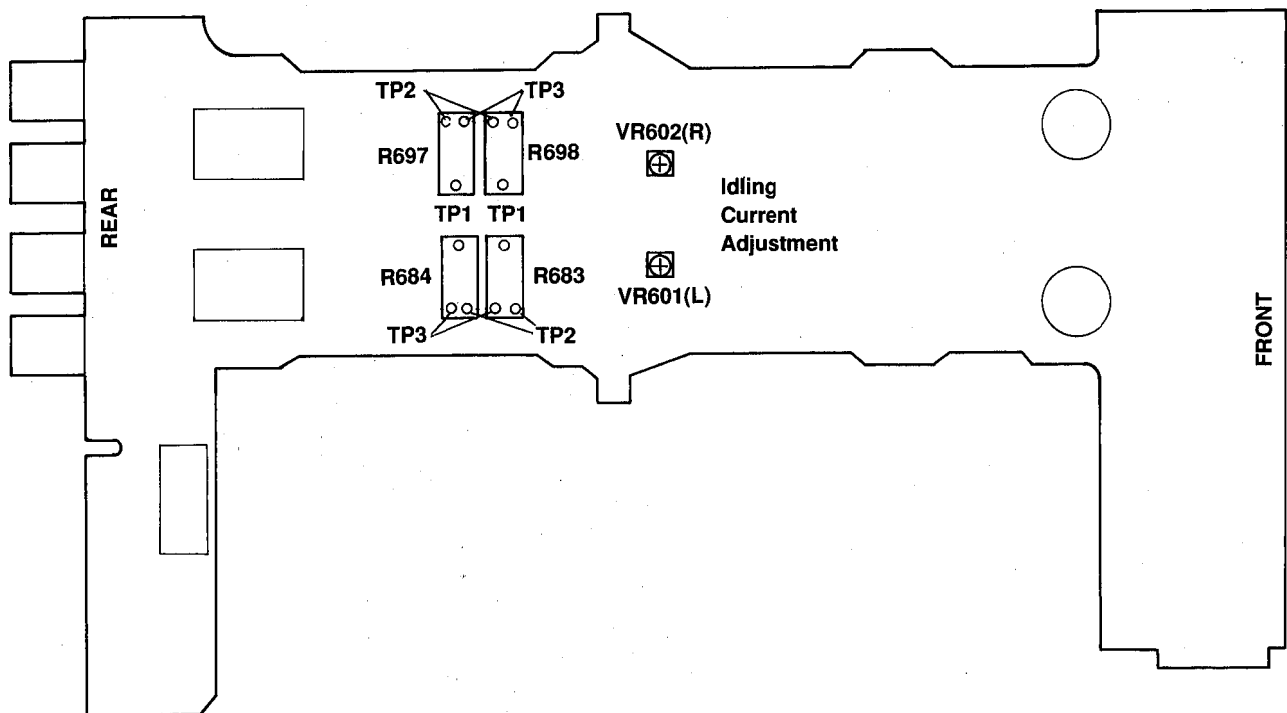

■ BLOCK DIAGRAM

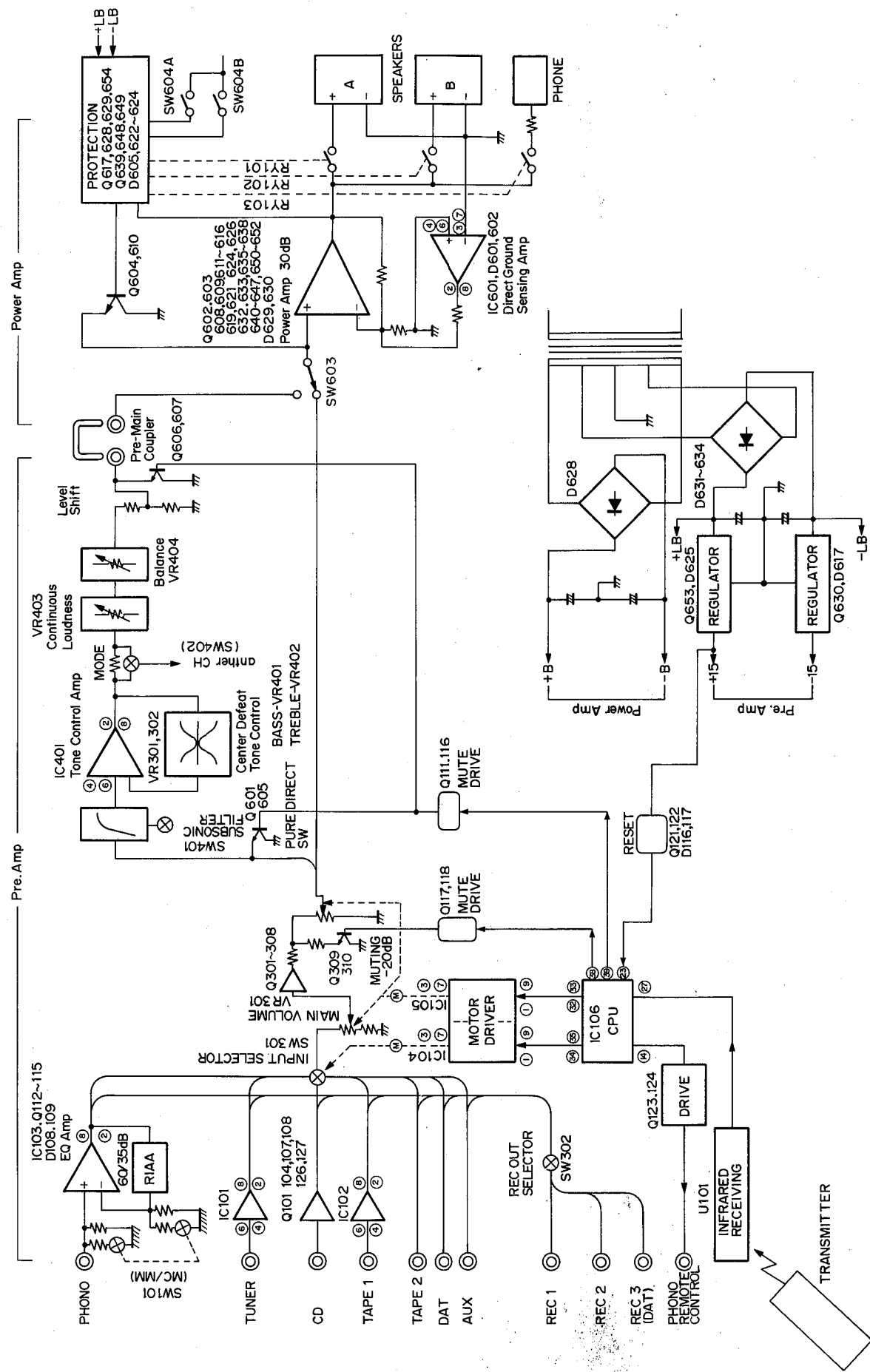

■ WIRING

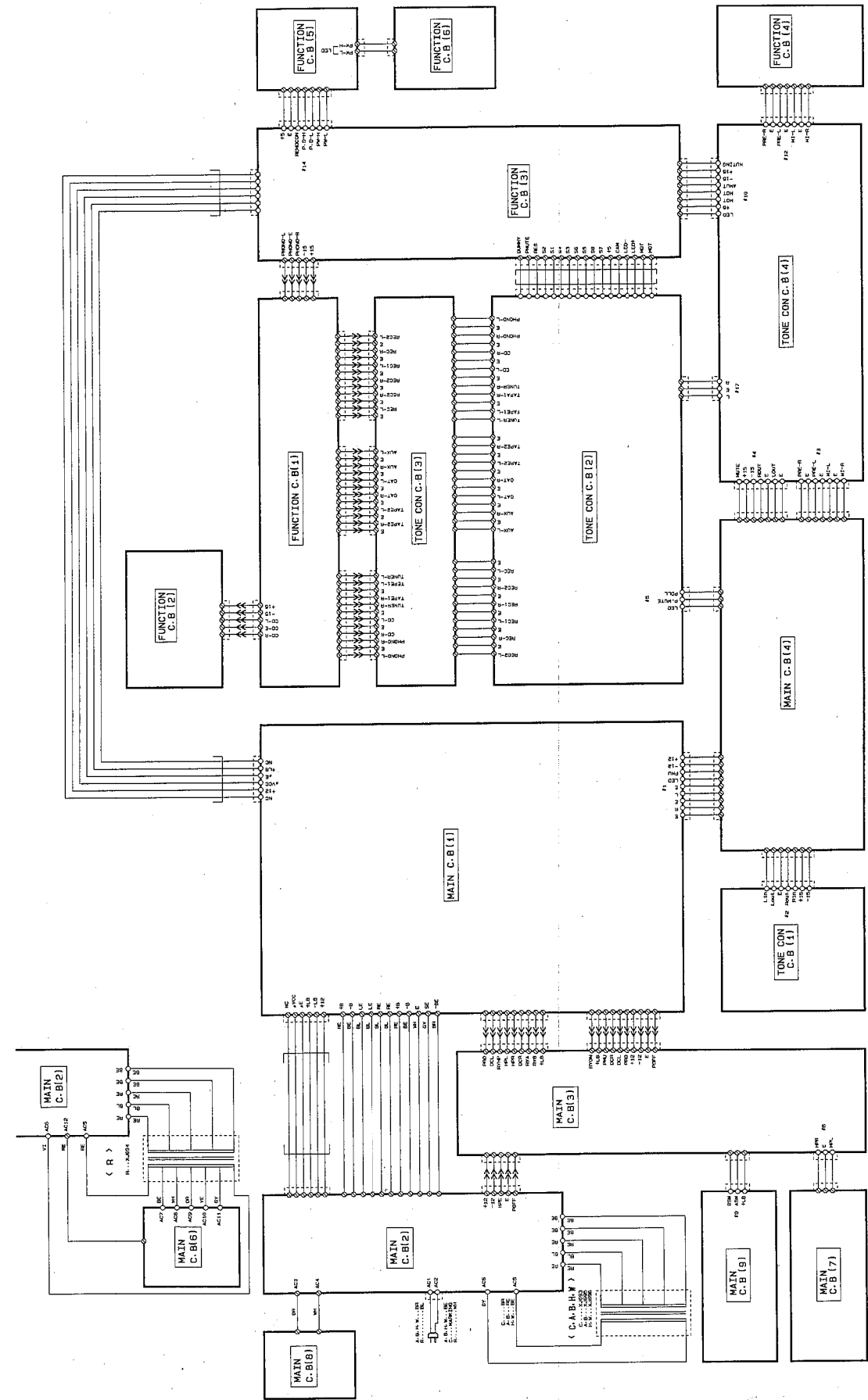

AX-750

PRINTED CIRCUIT BOARD (Function)

1
2
3
4
5
6
7
8

A B C D E F G H I J

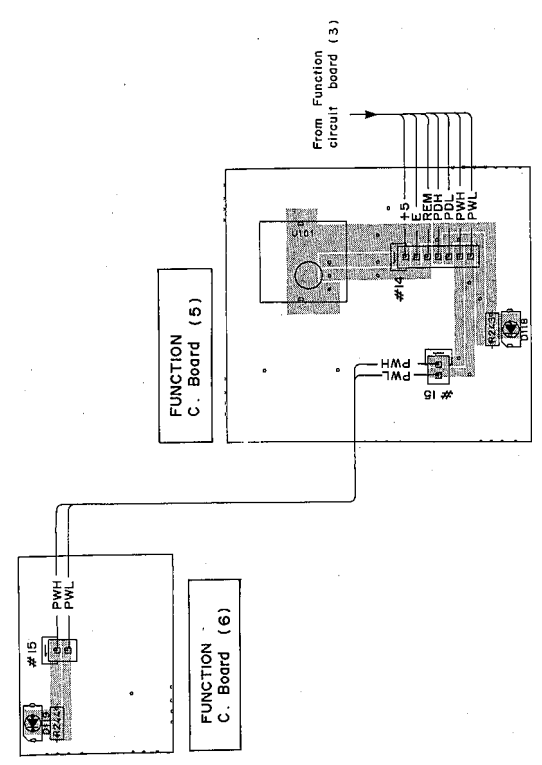
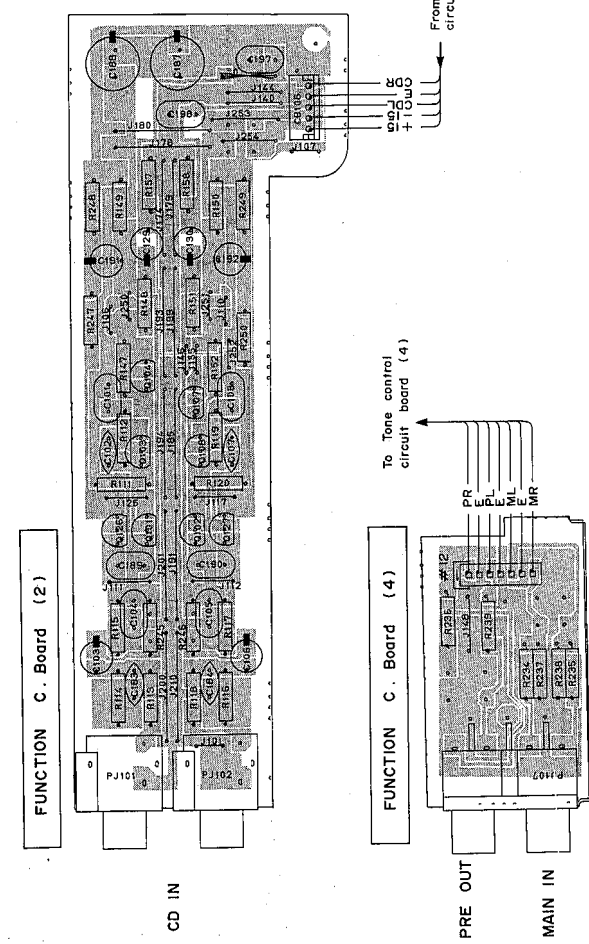
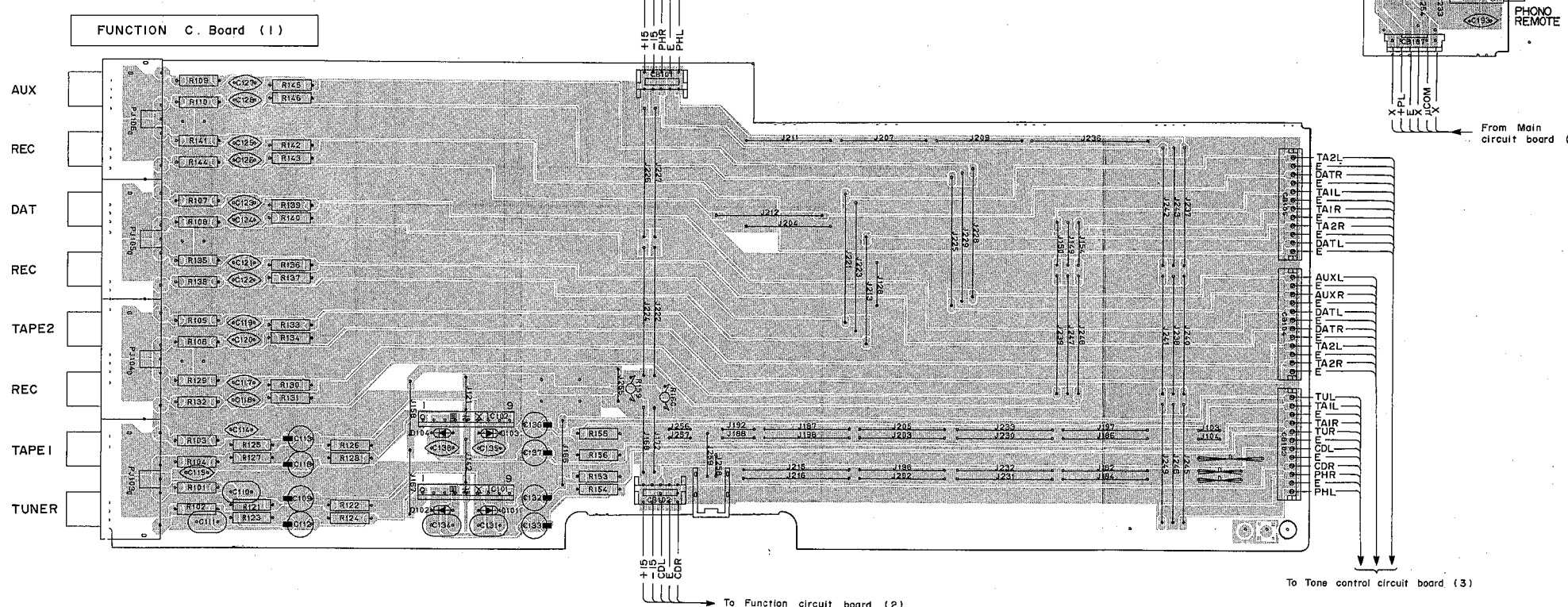
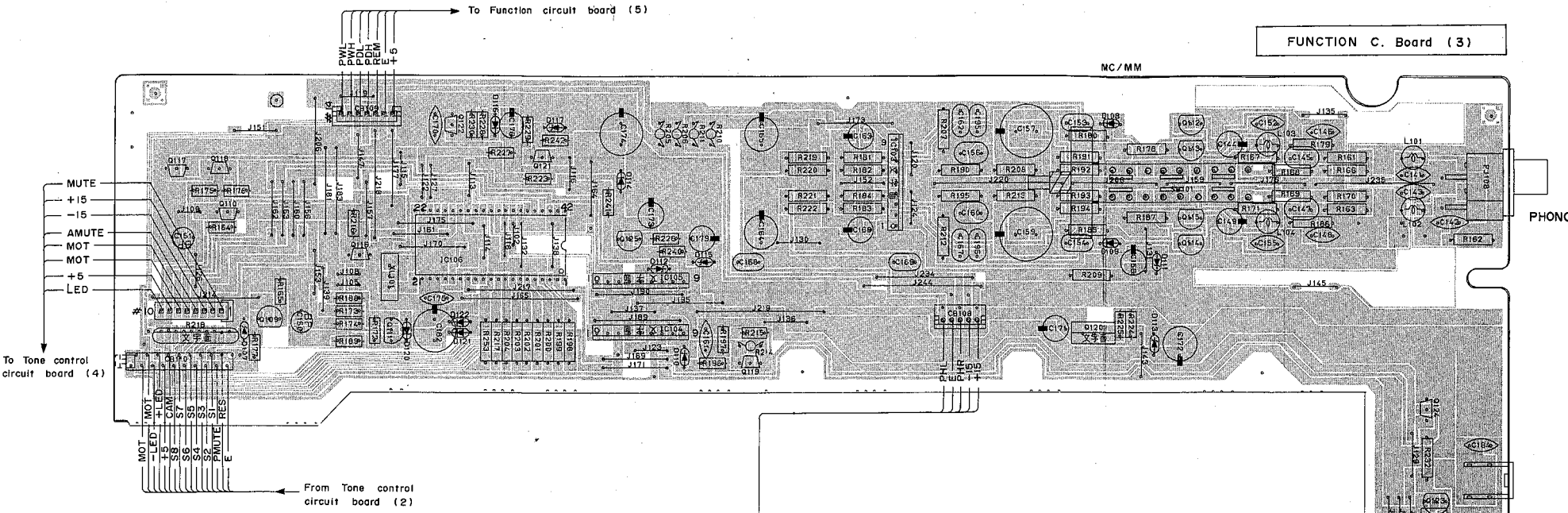

Semiconductors Location

Ref. No	Location
D 101	C 5
D 102	B 5
D 103	C 5
D 104	B 5
D 107	B 2
D 108	E 1
D 109	E 2
D 110	C 2
D 111	E 2
D 112	C 2
D 113	E 2
D 114	C 2
D 115	D 2
D 116	C 1
D 117	C 1
D 118	I 2
D 119	H 3
D 120	B 2
D 121	B 2
D 122	B 2
IC 101	C 5
IC 102	C 5
IC 103	D 1
IC 104	C 2
IC 105	C 2
IC 106	C 2
Q 101	H 5
Q 102	H 5
Q 103	H 5
Q 104	H 5
Q 107	H 5
Q 108	H 5
Q 109	B 2
Q 110	B 2
Q 111	B 2
Q 112	F 1
Q 113	F 1
Q 114	F 2
Q 115	F 2
Q 116	B 2
Q 117	A 2
Q 118	B 2
Q 119	D 2
Q 120	E 2
Q 121	C 1
Q 122	B 1
Q 123	G 3
Q 124	G 3
Q 125	C 2
Q 126	H 5
Q 127	H 5

PRINTED CIRCUIT BOARD (Tone Control)

●Semiconductors Location

Ref. No	Location
IC 401	B 5
Q 301	H 3
Q 302	H 3
Q 303	H 3
Q 304	F 3
Q 305	H 3
Q 306	F 3
Q 307	H 3
Q 308	G 3
Q 309	G 2
Q 310	G 2

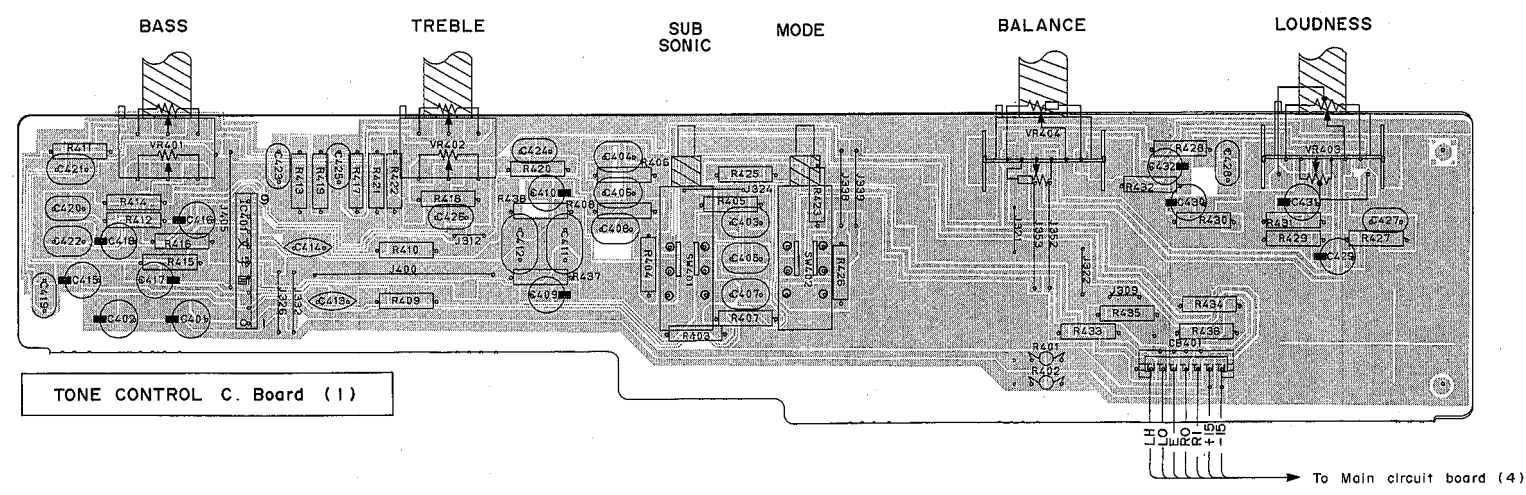
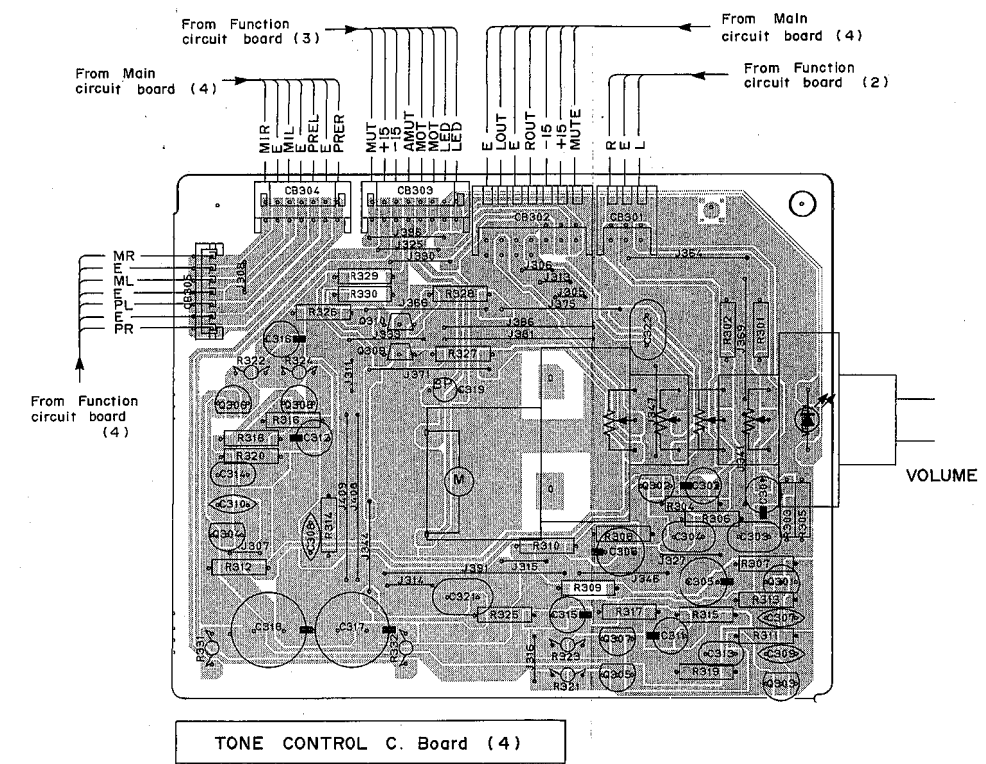
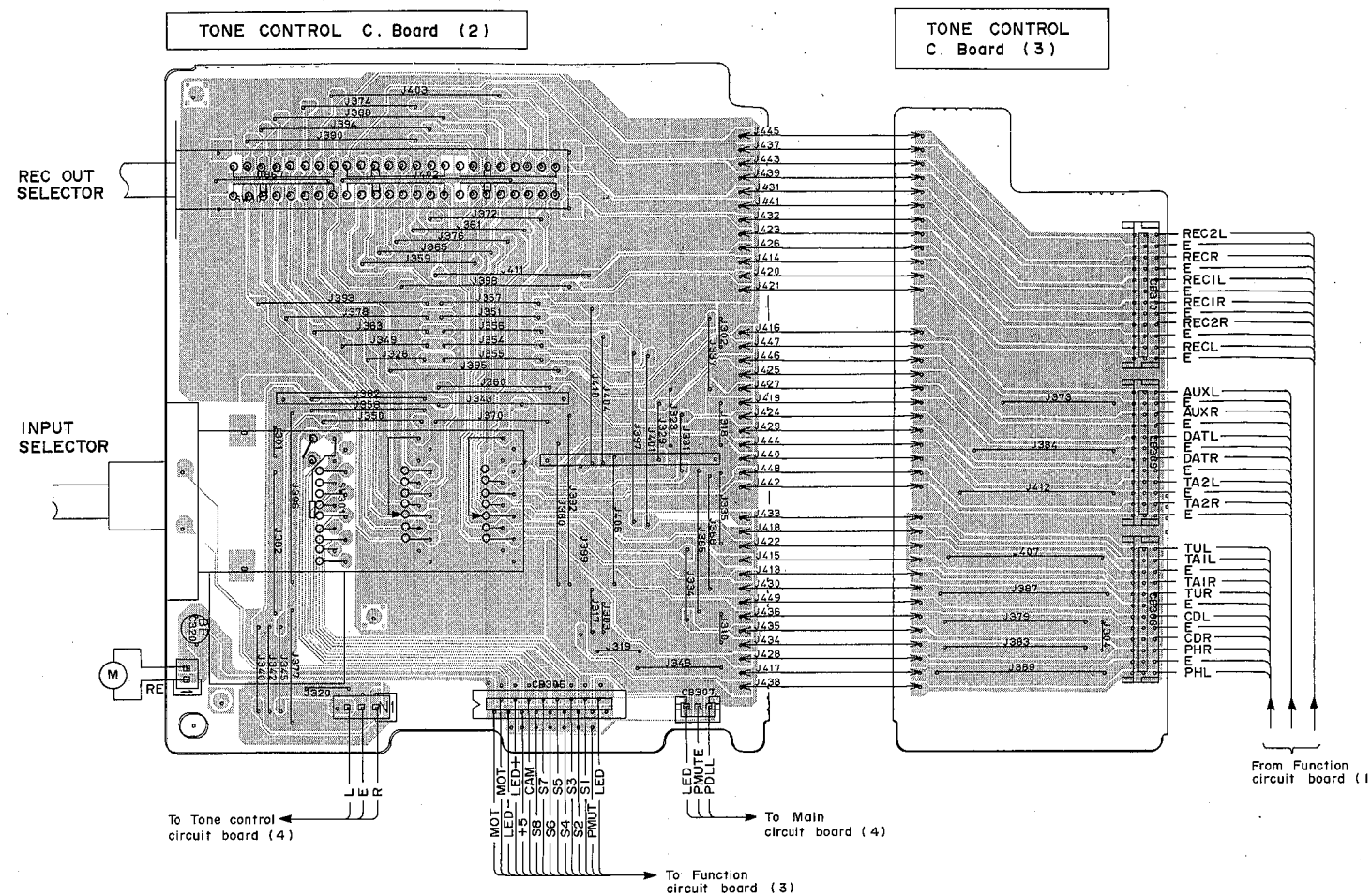

1
2
3
4
5
6
7

AX-750

PRINTED CIRCUIT BOARD

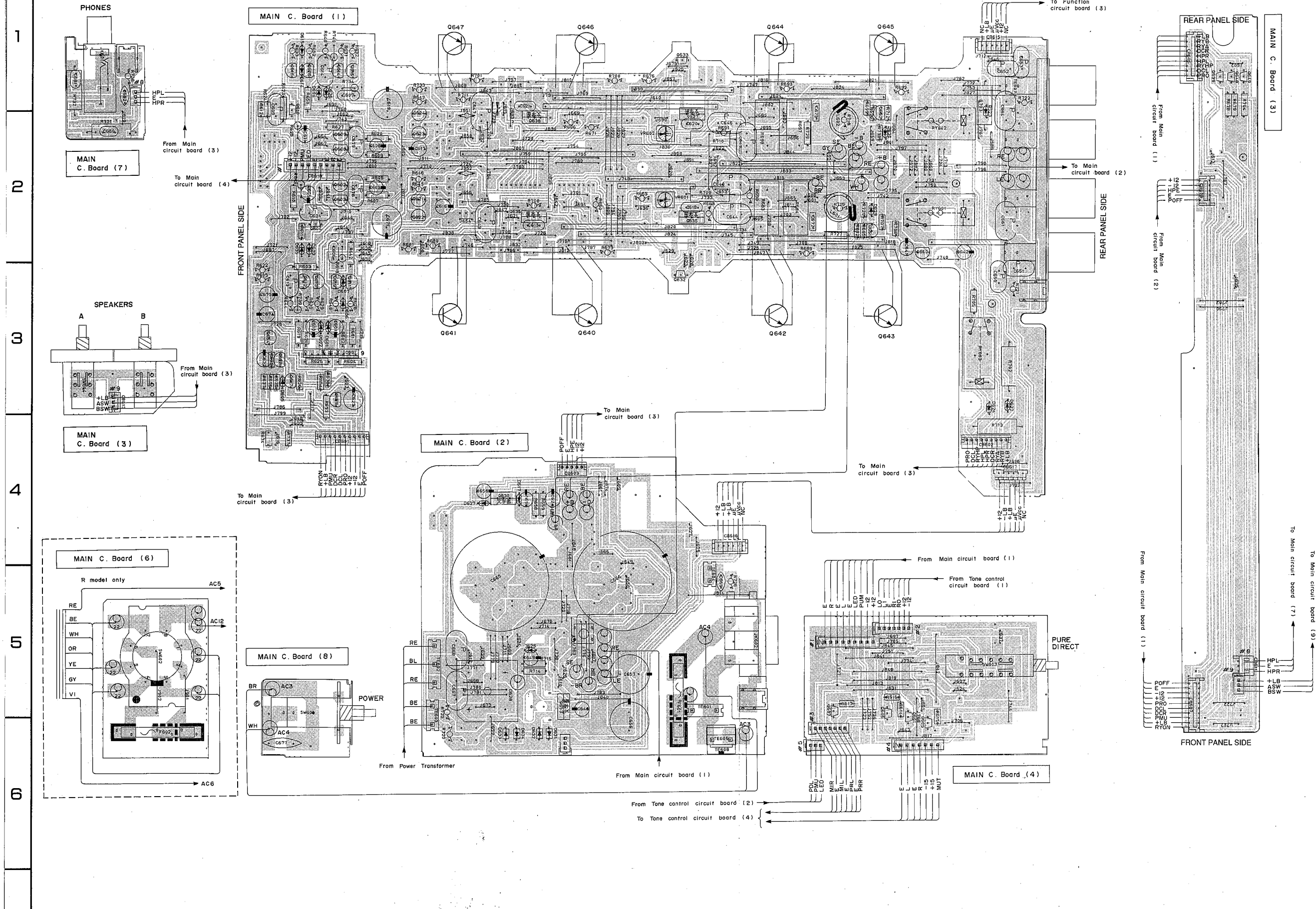

● Semiconductors Location

Ref. No	Location
D 601	B 3
D 602	B 3
D 603	B 2
D 604	B 1
D 605	B 3
D 606	C 3
D 617	C 3
D 614	B 1
D 615	B 1
D 617	D 4
D 622	G 3
D 623	G 1
D 624	G 3
D 625	D 5
D 627	D 4
D 628	D 5
D 629	F 2
D 630	F 2
D 631	D 6
D 632	D 6
D 633	D 6
D 634	D 6
D 635	B 2
D 636	B 1
IC 601	C 3
Q 601	F 6
Q 602	C 2
Q 603	C 2
Q 604	B 2
Q 605	F 6
Q 606	F 6
Q 607	F 6
Q 608	C 2
Q 609	C 2
Q 610	B 1
Q 611	C 3
Q 612	B 3
Q 613	B 3
Q 614	C 1
Q 615	C 1
Q 616	B 1
Q 617	B 3
Q 619	C 3
Q 621	C 2
Q 622	C 2
Q 623	C 2
Q 624	C 2
Q 626	B 1
Q 628	B 3
Q 629	C 3
Q 630	D 4
Q 631	D 3
Q 632	E 3
Q 633	E 1
Q 634	D 1
Q 635	D 2
Q 636	E 2
Q 637	E 2
Q 638	D 2
Q 639	H 1
Q 640	D 3
Q 641	C 3
Q 642	F 3
Q 643	F 3
Q 644	E 1
Q 645	F 1
Q 646	D 1
Q 647	C 1
Q 648	I 1
Q 649	I 1
Q 650	F 2
Q 651	F 2
Q 652	F 2
Q 653	D 6
Q 654	B 3
VR601	E 2
VR602	E 2

1
2
3
4
5
6
7

SCHEMATIC DIAGRAM

CAPACITOR		RESISTOR	
REMARKS	PARTS NAME	REMARKS	PARTS NAME
NO MARK	ELECTROLYTIC CAPACITOR	NO MARK	CARBON FILM RESISTOR (1/8W)
◎	TANTALUM CAPACITOR	◎	CARBON FILM RESISTOR (1/4W)
◇	NO MARK CERAMIC CAPACITOR	△	METAL OXIDE FILM RESISTOR
●	AXIAL LEAD CERAMIC CAPACITOR	□	METAL FILM RESISTOR
○	DISC CERAMIC CAPACITOR	◇	METAL GLAZE RESISTOR
○	POLYESTER FILM CAPACITOR	□	FILM PROOF CARBON FILM RESISTOR
○	POLYPROPYLENE FILM CAPACITOR	◇	TEMP. COEFF. METAL RESISTOR
○	MICA CAPACITOR	○	TEMP. VARIABLE RESISTOR
○	POLYPROPYLENE FILM CAPACITOR	○	TRIMP RESISTOR
○	PERFORMANACE CERAMIC CAPACITOR		

NOTICE
 (J)..... Japanese model
 (U)..... U.S.A. model
 (C)..... Canadian model
 (A)..... Australian model
 (G)..... European model
 (I)..... Italian model
 (R)..... General model
 (P)..... PP model

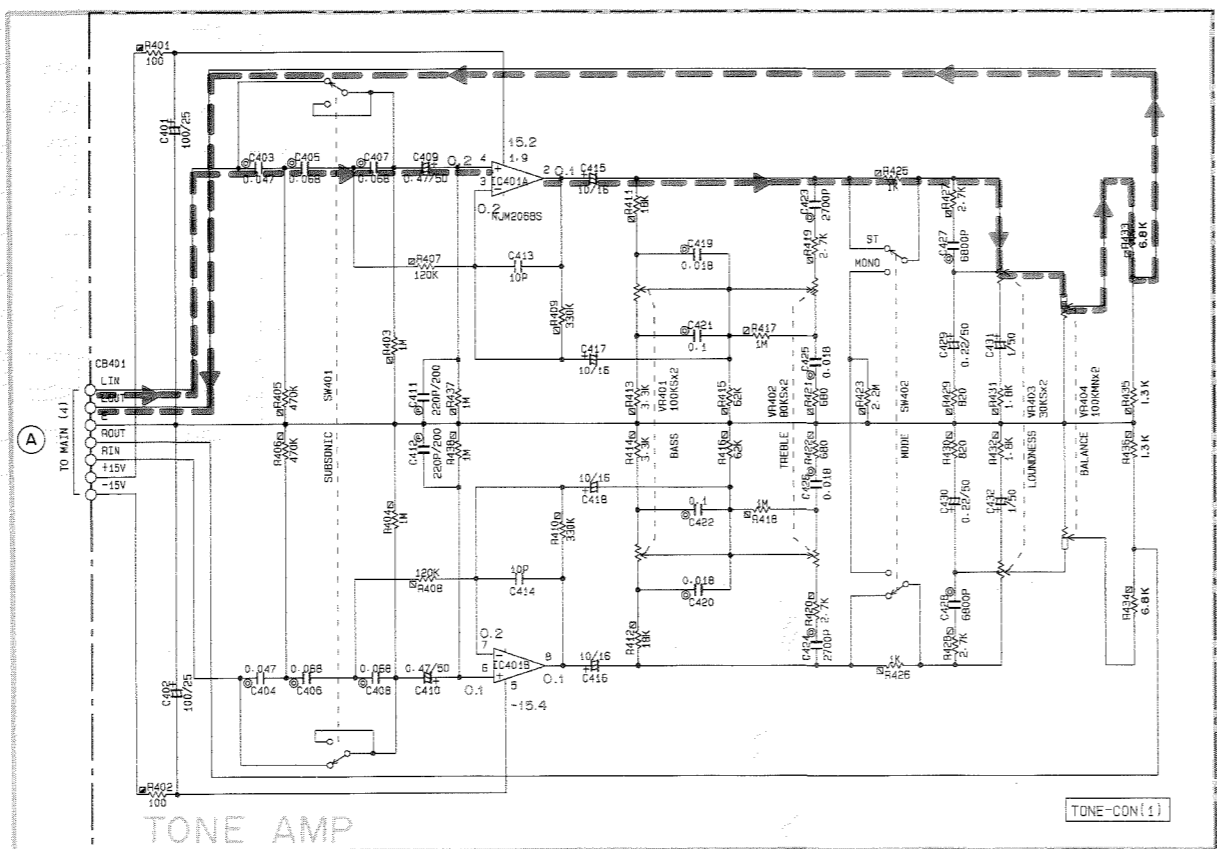
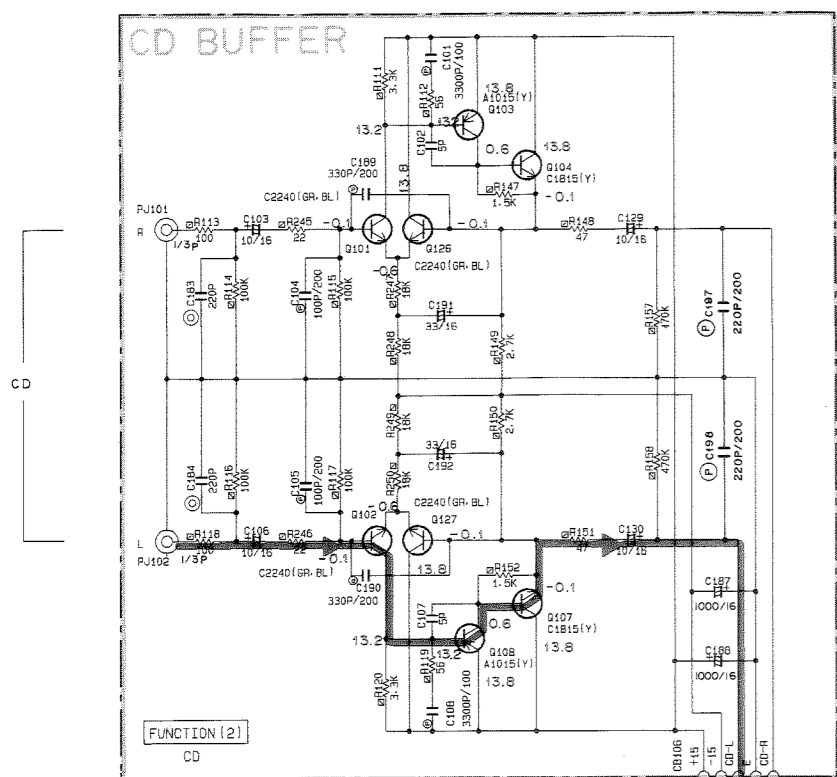

— DIRECT SIGNAL
 - - - TONE CONTROL SIGNAL
 - · - · PHONO SIGNAL

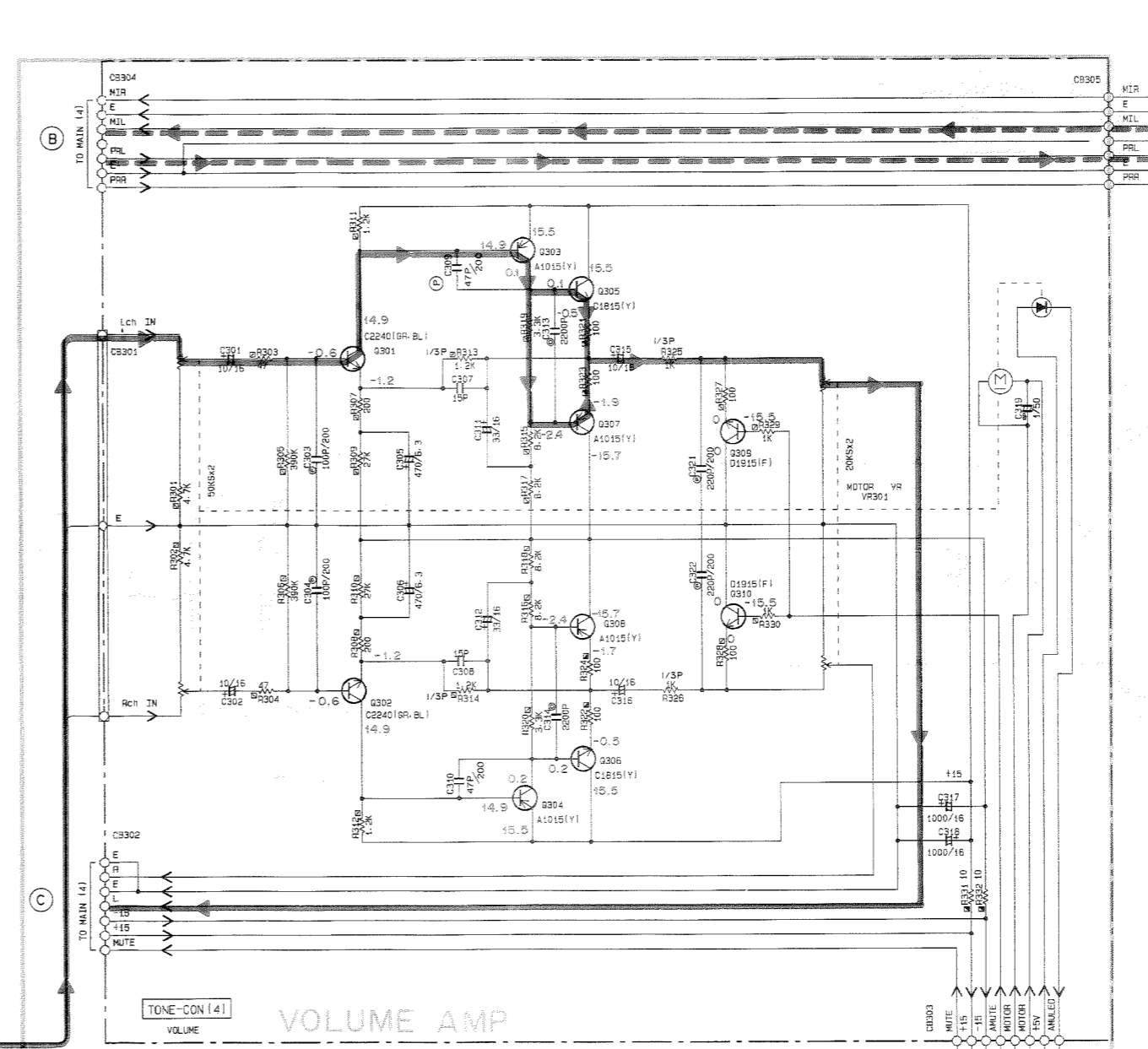
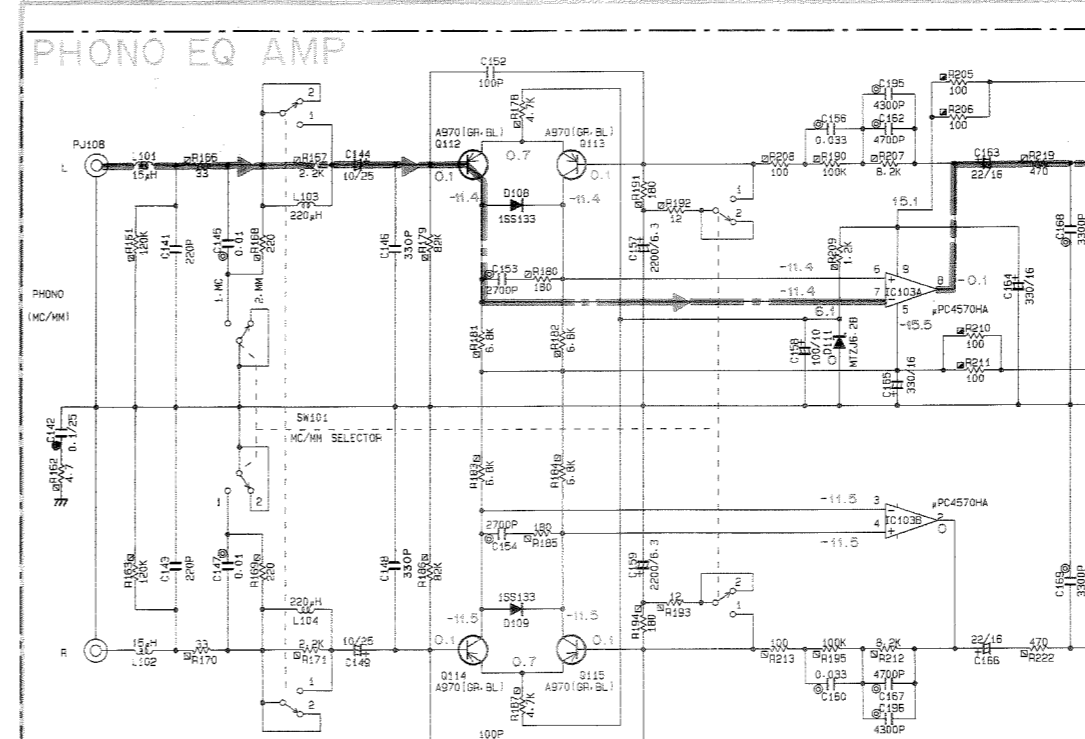
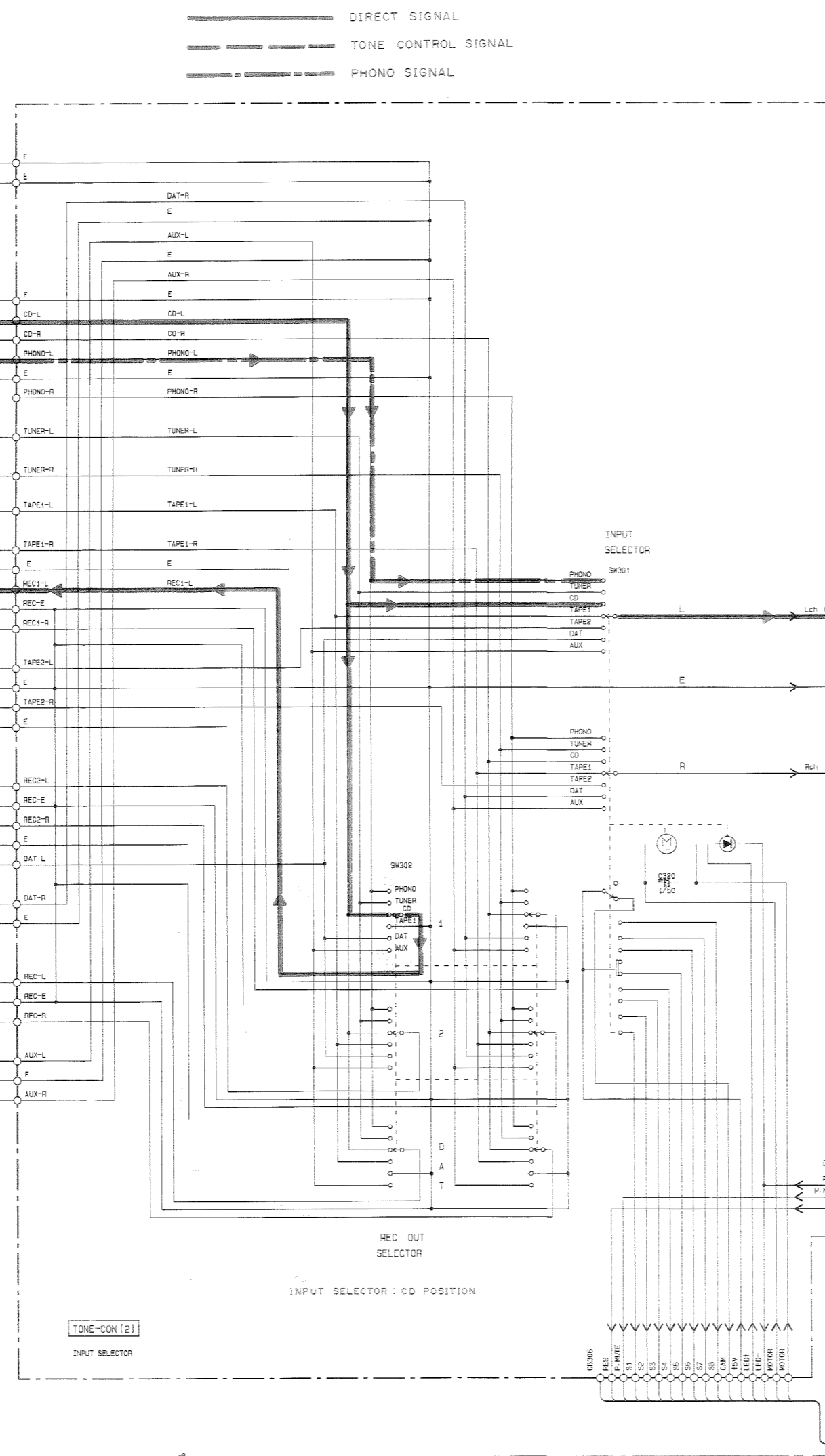
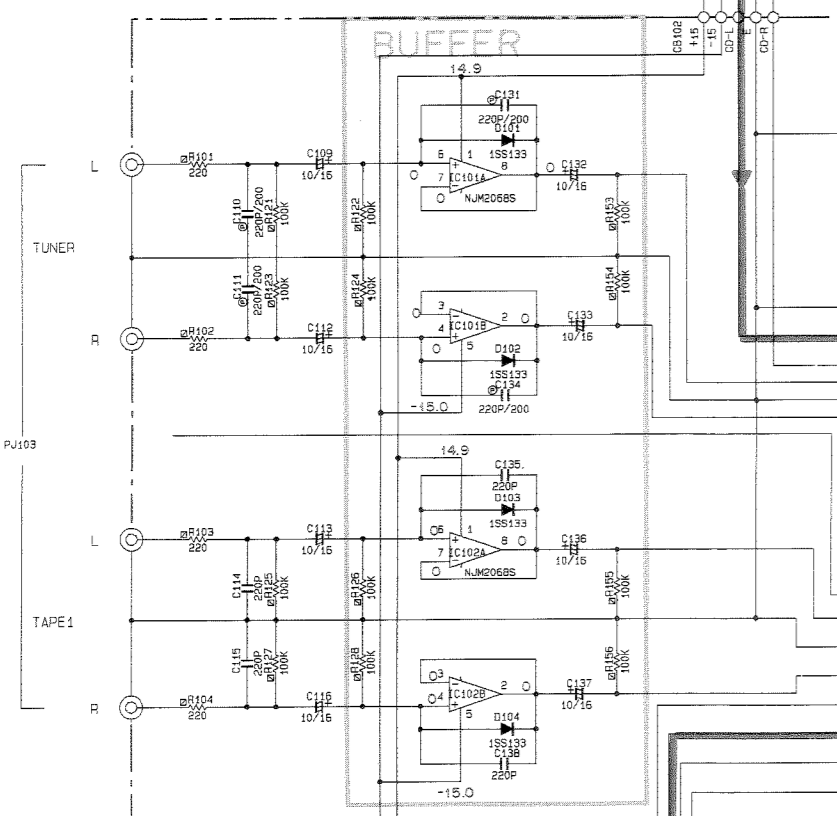

Part No.	Reference Part No.	Part Name
F1	0110-121	2SA1115 (P)
		2SA1305A (G, R, S)
		2SA1939 (S, M)
F2	0122	2SC1740 (S, M)
		2SC2003 (S, M)
		2SC2313 (S, M)

IC106:LC6520H
 (4-bit μCOM)

PIN No.	PIN NAME	I/O	FUNCTION	PIN No.	PIN NAME	I/O	FUNCTION
1	PA2	IO	Not used	22	OSC2	—	—
2	PA3	IO	Not used (H)	23	RESET	I	Reset input
3	PB0	—	S1 : Selector position data	24	PF0	IO	Not used
4	PB1	—	S2	25	PF1	IO	Not used
5	PB2	—	S3	26	PF2	IO	Not used
6	PB3	—	S4	27	PF3	IO	Remote control Data input
7	PC0	IO	S5	28	PG0	IO	Not used
8	PC1	IO	S6	29	PG1	IO	Not used (GND)
9	PC2	IO	S7	30	PG2	IO	Not used
10	PC3	IO	S8	31	PG3	IO	Not used
11	PD0	IO	CAM : Cam position data	32	PI0	IO	Volume control signal 2
12	PD1	IO	Not used (L : 6ch set)	33	PI1	IO	Volume control signal 1
13	PD2	IO	Not used (GND)	34	PI2	IO	Selector control signal 2
14	PD3	IO	PLAY/CUT (Player control)	35	PI3	IO	Selector control signal 1
15	PE0	IO	Not used	36	PJ0	IO	Not used (GND)
16	PE1	IO	Not used	37	PJ1	IO	Audio muting LED control
17	PE2	IO	Not used	38	PJ2	IO	Audio muting control signal
18	PE3	IO	Not used (GND)	39	PJ3	IO	Muting control signal
19	TEST	—	GND	40	VDD	—	+5V
20	VSS	—	GND	41	PA0	IO	Not used
21	OSC1	—	—	42	PA1	IO	Not used

IC BLOCK

IC101,102:NMJ4558S
 IC401:NMJ2068S
 IC103:μPC4570HA
 (Dual Op-amp)

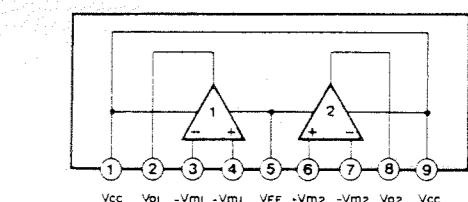

IC104,105:TA7291S
 (Full Bridge Motor Driver)

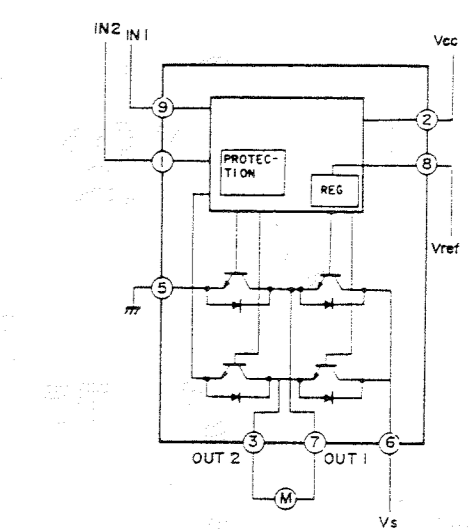

IC106:LC6520H
 (4-bit μCOM)

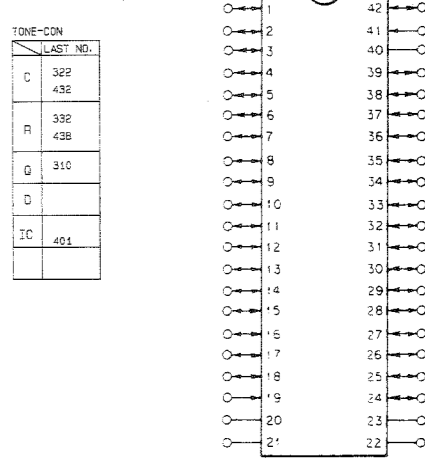
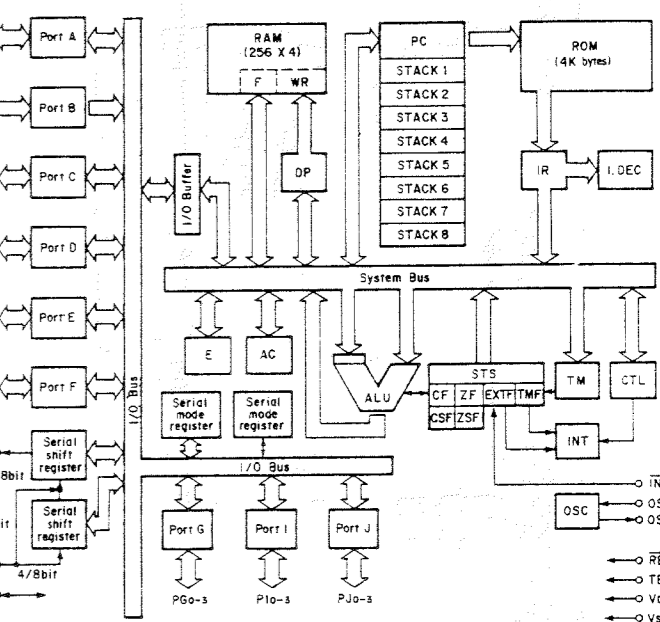
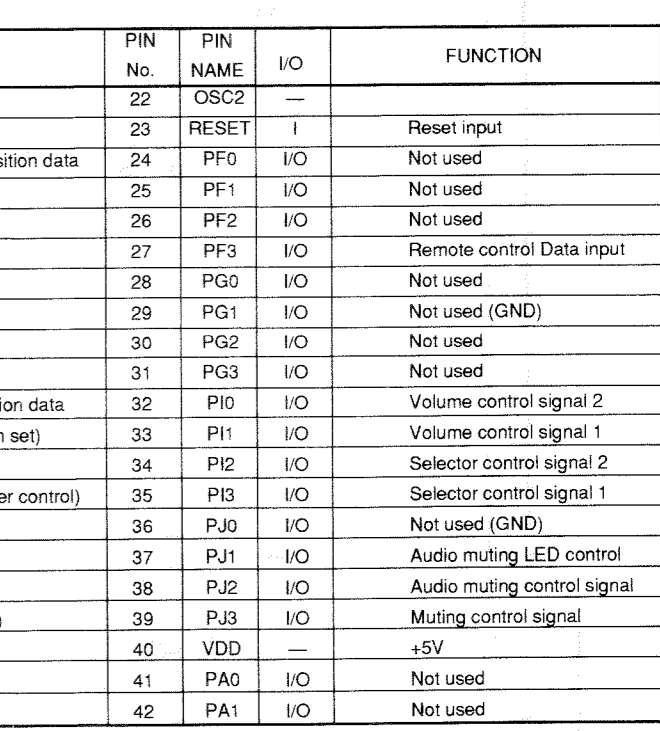

DTC124ES	2SA1115	2SD438	2SC2240	2SC3852	All Diodes	NJM4558S	LC6520H
DTA114	2SC1740S	2SA970	2SC2705			NJM2068S	
DTA144	2SD1915	2SA1015	2SB560			TA7291	
DTC144		2SA1145	2SC2060			μPC4570HA	
DTC114		2SC1815					

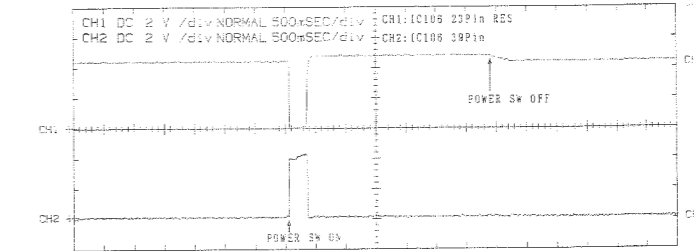
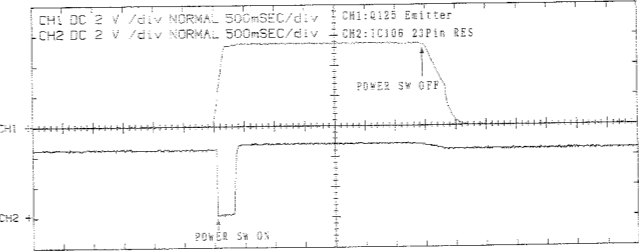
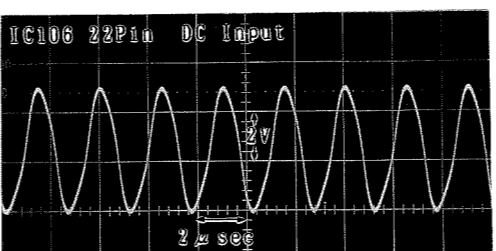

CAPACITOR	
REMARKS	PARTS NAME
NO MARK	ELECTROLYTIC CAPACITOR
⊗	TANTALUM CAPACITOR
NO MARK	CERAMIC CAPACITOR
⊙	AXIAL LEAD CERAMIC CAPACITOR
⊖	POLYESTER FILM CAPACITOR
○	POLYSTYRENE FILM CAPACITOR
○	MICA CAPACITOR
⊖	POLYPROPYLENE FILM CAPACITOR
⊖	SEMICONDUCTIVE CERAMIC CAPACITOR

RESISTOR	
REMARKS	PARTS NAME
NO MARK	CARBON FILM RESISTOR (1/2W)
□	CARBON FILM RESISTOR (1/4W)
□	METAL FILM RESISTOR
△	METAL FILM RESISTOR
□	METAL PLATE RESISTOR
□	FIRE PROOF CARBON FILM RESISTOR
□	CEMENT MOLDED RESISTOR
□	SEMI VARIABLE RESISTOR
□	CHIP RESISTOR

NOTICE
 (J)..... Japanese model
 (U)..... U.S.A model
 (C)..... Canadian model
 (A)..... Australian model
 (G)..... European model
 (B)..... British model
 (P)..... General model
 (R)..... RFP model

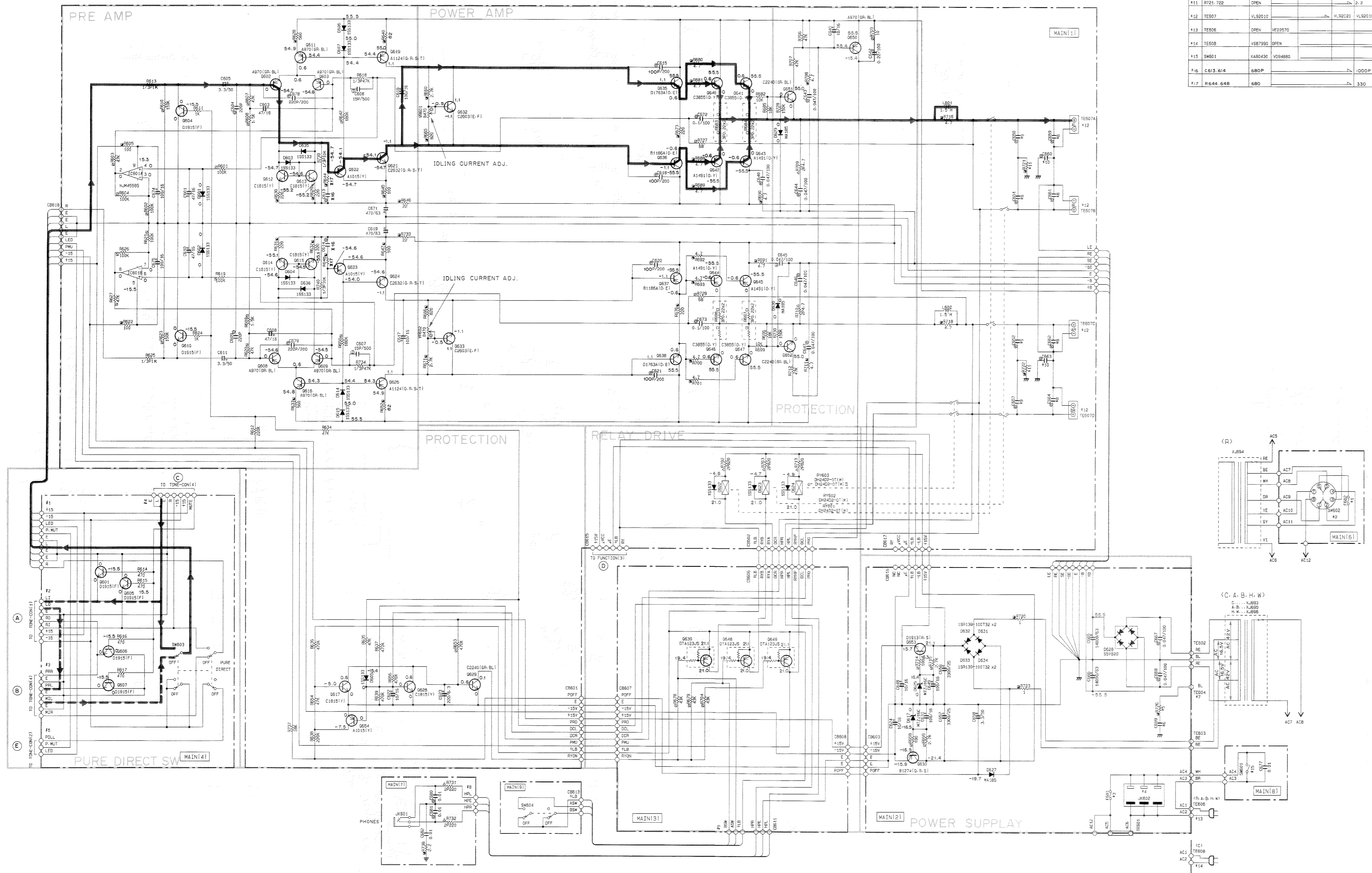

	C	R	A/B	H	K
*1	F802	OPEN	4.5A250V	OPEN	
*2	SW602	OPEN	V489180	OPEN	
*3	F801	10A250V		14.0A250V	
*4	SW602	V130780		OPEN	
*5	F729	OPEN			2.2
*6	CB59	OPEN			0.022
*7	TE804	OPEN			LA02011
*8	CB59-051-052-054	OPEN			0.012/100
*9	CB50-053	OPEN			3900P/100
*10	CB50-053	OPEN			0.022/100
*11	F721-722	OPEN			2.2
*12	TE807	VLS2010			VLS2010 VLS2010
*13	TE806	OPEN	VE22970		
*14	TE808	V58730	OPEN		
*15	SW601	KAB0430	Y084880		
*16	C613-614	680P			1000P
*17	R-644-648	680			330

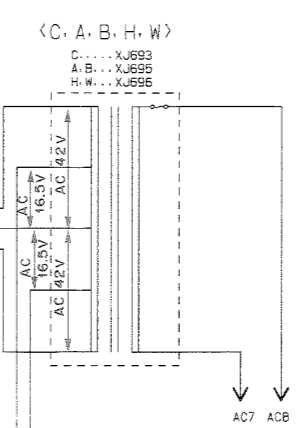
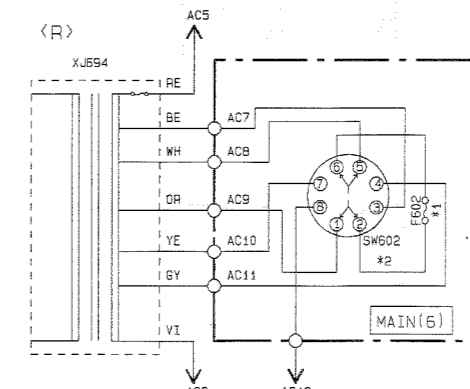

LAST NO.
C 582
R 740
S 054
D 538
IC 501

2SD1915 DTA123ES	2SA970 2SA1015 2SA1145 2SC1815 2SC2240 2SC2705	2SA1124 2SC2632 2SB1274 2SD1913	2SD1763 2SS1185	SSVB20	All Diodes	2SA1491 2SC3855
---------------------	---	--	--------------------	--------	------------	--------------------

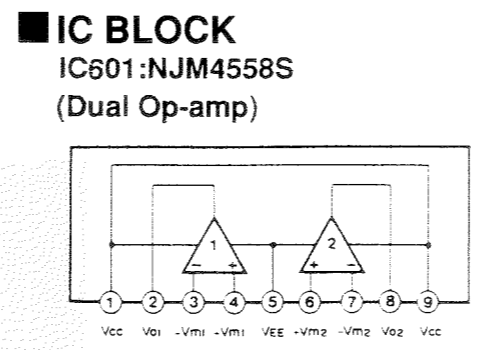

PARTS LIST

■ ELECTRICAL PARTS

■ WARNING

Components having special characteristics are marked  and must be replaced with parts having specifications equal to those originally installed.

• Carbon resistors 1/6 W are not included in the ELECTRICAL PARTS list. For the parts No. of the carbon resistor, refer to the last Page.

Ref. NO.	PART NO.	Description			部 品 名	Remarks	Markets	ランク
*	VL533800	FUNCTION CIRCUIT BOARD			ファンクションシート			
	FA153270	MYLAR FILM CAP	2700pF	50V	マイラーコン	C153, 154		
	FA153330	MYLAR FILM CAP	3300pF	50V	マイラーコン	C168, 169		
	FA153240	MYLAR FILM CAP	2400pF	50V	マイラーコン	C195, 196		
	FA153680	MYLAR FILM CAP	6800pF	50V	マイラーコン	C162, 167		
	FA154100	MYLAR FILM CAP	0.01uF	50V	マイラーコン	C145, 147		
	FA154330	MYLAR FILM CAP	0.033uF	50V	マイラーコン	C156, 160		
	VK984200	POLYPROPYLENE FILM CAP	220pF	50V	PPコン	C183, 184		
	VK533900	POLYPROPYLENE FILM CAP	100pF	200V	PPコン	C104, 105		
	VK534000	POLYPROPYLENE FILM CAP	220pF	200V	PPコン	C110, 111, 131, 134, 197,		
**	VL972900	POLYPROPYLENE FILM CAP	330pF	200V	PPコン	198 C189, 190		
**	VL884000	POLYPROPYLENE FILM CAP	3300pF	100V	PPコン	C101, 108		
	FG210500	CERAMIC CAP	5pF	50V	セラコン	C102, 107		
	FG212100	CERAMIC CAP	100pF	50V	セラコン	C152, 155		
	FG212220	CERAMIC CAP	220pF	50V	セラコン	C114, 115, 117-128, 135, 138, 141, 143		
	FG244100	CERAMIC CAP	0.01uF	50V	セラコン	C193, 194		
	VG287200	ELECTROLYTIC CAP	10uF	16V	ケミコン	C103, 106, 109, 112, 113, 116, 129, 130, 132, 133, 136, 137, 171, 173, 179		
	VG286800	ELECTROLYTIC CAP	100uF	10V	ケミコン	C158		
	VG287300	ELECTROLYTIC CAP	22uF	16V	ケミコン	C163, 166		
	VG287400	ELECTROLYTIC CAP	33uF	16V	ケミコン	C191, 192		
	VG287800	ELECTROLYTIC CAP	330uF	16V	ケミコン	C164, 165, 172		
	VG288500	ELECTROLYTIC CAP	10uF	25V	ケミコン	C144, 149		
*	VH758800	ELECTROLYTIC CAP	330uF	25V	ケミコン	C182		
	VG290500	ELECTROLYTIC CAP	1uF	50V	ケミコン	C176		
	VG288000	ELECTROLYTIC CAP	1000uF	16V	ケミコン	C187, 188		
	UJ719220	ELECTROLYTIC CAP	2200uF	6.3V	ケミコン	C157, 159		
	VK166100	ELECTROLYTIC CAP	1uF	50V	BPケミコン	C150, 151		
	VD930900	SEMI-CONDUCTIVE CERAMIC CAP	0.1uF	25V	半導体セラコン	C142, 161, 170, 175		
	VB170100	ELECTROLYTIC CAP	4700uF	5.5V	バックアップケミコン	C174		
	VF541100	COIL	15uH	ELF0505RA	コイル	L101, 102		
	VB056900	COIL	220uH		コイル	L103, 104		
	VK859300	CARBON RESISTOR	100 Ω	1/3W	カーボン抵抗	R113, 118		
	HV454100	FLAME PROOF CARBON RESISTOR	10 Ω	1/4W	不燃化カーボン抵抗	R214		
	HV454390	FLAME PROOF CARBON RESISTOR	39 Ω	1/4W	不燃化カーボン抵抗	R233, 254		
	HV455100	FLAME PROOF CARBON RESISTOR	100 Ω	1/4W	不燃化カーボン抵抗	R159, 160, 205, 206, 210, 211		
	HU595100	METAL FILM RESISTOR	100 Ω	1/4W	金属被膜抵抗	R225, 226		
	HU575180	METAL FILM RESISTOR	180 Ω	1/4W	金属被膜抵抗	R165		
	HU575200	METAL FILM RESISTOR	200 Ω	1/4W	金属被膜抵抗	R164		
	HU575220	METAL FILM RESISTOR	220 Ω	1/4W	金属被膜抵抗	R196, 197, 215		
	HU575680	METAL FILM RESISTOR	680 Ω	1/4W	金属被膜抵抗	R244		
	HU596100	METAL FILM RESISTOR	1K Ω	1/4W	金属被膜抵抗	R177, 224, 240, 241, 243		
	HU597100	METAL FILM RESISTOR	10K Ω	1/4W	金属被膜抵抗	R172, 173, 175, 229, 231		
	HU577150	METAL FILM RESISTOR	15K Ω	1/4W	金属被膜抵抗	R216		
	HU577390	METAL FILM RESISTOR	39K Ω	1/4W	金属被膜抵抗	R188		
	HU577470	METAL FILM RESISTOR	47K Ω	1/4W	金属被膜抵抗	R242		

* : New Parts (新規部品)

ランク : Japan only

Ref. NO.	PART NO.	Description	部 品 名		Remarks	Markets	ランク
	HU508100	METAL FILM RESISTOR	100KΩ	1/4W	金属被膜抵抗	R223, 227, 228, 230	
	HU578150	METAL FILM RESISTOR	150KΩ	1/4W	金属被膜抵抗	R189	
	HU508220	METAL FILM RESISTOR	220KΩ	1/4W	金属被膜抵抗	R174, 176	
*	VL948600	RESISTOR ARRAY	47KΩ×9		抵抗アレイ	R218	
	XA956A00	IC	NJH2068S		IC	IC101, 102	
	XB247301	IC	uPC4570HA		IC	IC103	
	XF557A00	IC	TA7291S		IC	IC104, 105	
	XJ577A00	IC	LC8520H-4690		IC	IC106	
	VF926500	LIGHT DETECTING MODULE	GP1U501X		リモコン受光ユニット	U101	
	VK333500	PUSH SWITCH	SPUH19		プッシュSW	SW101	
	LR202260	PIN JACK			ピンジャック	PJ108	
	LR401030	PIN JACK	4P	T5857-A	ピンジャック	PJ107	
	VL552500	PIN JACK	1P	YKC21-3048	ピンジャック	PJ101, 102	
	VJ249500	PIN JACK	4P	YKC21-3077	ピンジャック	PJ103-106	
	VJ726800	MINITURE JACK			モノラル ミニジャック	JK101 REMOTE-PHONE	
	VL548400	SHORT PLUG	FJ	6P	FJショートプラグ	CB107	
	VI378300	CONNECTOR	NQ	5P	コネクターソケット	CB101, 102	
	VA252300	CONNECTOR	MQ	5P	MQコネクター	CB106, 108	
	VA252400	MQ CONNECTOR			MQコネクター	CB103-105	
	VD005000	BASE PIN	PH	i-TYPE 7P TE	ベースピン	CB109	
	VL023700	WAFER	5062	17P TE	サポーティングウェハー	CB110	
	VB759100	CERAMIC RESONATOR	4MHz	EFO-FC400	セラミック振動子	XL101	
	IA097000	TRANSISTOR	2SA970	GR, BL	トランジスタ	Q112-115	
	IA093320	TRANSISTOR	2SA933S	Q, R	トランジスタ	Q119, 121	
	IA101521	TRANSISTOR	2SA1015	Y	トランジスタ	Q103, 108, 109, 111	
	IB056020	TRANSISTOR	2SB560	E, F	トランジスタ	Q123	
	IC181500	TRANSISTOR	2SC1815	Y	トランジスタ	Q104, 107	
	IC224030	TRANSISTOR	2SC2240	GR, BL	トランジスタ	Q101, 102, 126, 127	
	IC174020	TRANSISTOR	2SC1740S	R, S	トランジスタ	Q122	
	IC206010	TRANSISTOR	2SC2060	P, Q, R	トランジスタ	Q125	
	VC938500	TRANSISTOR	2SC3852		トランジスタ	Q120	
	VD678500	DIGITAL TRANSISTOR	DTA114ES		デジタルトランジスタ	Q118	
	VD678700	DIGITAL TRANSISTOR	DTC114ES		デジタルトランジスタ	Q110	
	VG722000	DIGITAL TRANSISTOR	DTC144ES		デジタルトランジスタ	Q116, 117	
	VF331200	DIGITAL TRANSISTOR	DTC124ES		デジタルトランジスタ	Q124	
	1F004000	DIODE	1SS133		ダイオード	D101-104, 108, 109, 114, 116, 120-122	
	VG435800	ZENER DIODE	WTZJ3.0A		ツェナーダイオード	D107	
	VG436800	ZENER DIODE	WTZJ4.3B		ツェナーダイオード	D117	
	VG437000	ZENER DIODE	WTZJ4.7A		ツェナーダイオード	D110	
	VG437500	ZENER DIODE	WTZJ5.1C		ツェナーダイオード	D112	
	VG438000	ZENER DIODE	WTZJ6.2B		ツェナーダイオード	D111, 115	
	VG440300	ZENER DIODE	WTZJ12C		ツェナーダイオード	D113	
	VF402500	LED	SLR-34DC3H3 (ORA)		LED	D118	
	VI013600	LED	SLR-34VC3H3 (RED)		LED	D119	
	VL792100	CABLE	17P	148mm	HCUジョイナー		
	VB066900	PIN	JMSA-6024		スタイルピン		
	BB071360	SCREW TERMINAL	8.3×13		ネジ端子		

* : New Parts (新規部品)

ランク : Japan only

Ref. NO.	PART NO.	Description	部 品 名		Remarks	Markets	ランク
	VL533800	TONE CONTROL CIRCUIT BOARD	トーンコントロールシート				
	FA153220	MYLAR FILM CAP	2200pF	50V	マイラーコン	C313,314	
	FA153270	MYLAR FILM CAP	2700pF	50V	マイラーコン	C423,424	
	FA153680	MYLAR FILM CAP	6800pF	50V	マイラーコン	C427,428	
	FA154180	MYLAR FILM CAP	0.018uF	50V	マイラーコン	C419,420,425,426	
	FA154470	MYLAR FILM CAP	0.047uF	50V	マイラーコン	C403,404	
	FA154680	MYLAR FILM CAP	0.068uF	50V	マイラーコン	C405-408	
	FA155100	MYLAR FILM CAP	0.1uF	50V	マイラーコン	C421,422	
	VK533800	POLYPROPYLENE FILM CAP	47pF	200V	PPコン	C309,310	
	VK533900	POLYPROPYLENE FILM CAP	100pF	200V	PPコン	C303,304	
	VK534000	POLYPROPYLENE FILM CAP	220pF	200V	PPコン	C321,322,411,412	
	FG211100	CERAMIC CAP	10pF	50V	セラコン	C413,414	
	FG211150	CERAMIC CAP	15pF	50V	セラコン	C307,308	
	VG286500	ELECTROLYTIC CAP	470uF	0.3V	ケミコン	C305,306	
	VG287200	ELECTROLYTIC CAP	10uF	16V	ケミコン	C301,302,315,316,	
						415-418	
	VG287400	ELECTROLYTIC CAP	33uF	16V	ケミコン	C311,312	
	VG288900	ELECTROLYTIC CAP	100uF	25V	ケミコン	C401,402	
	VG290100	ELECTROLYTIC CAP	0.22uF	50V	ケミコン	C429,430	
	VG290300	ELECTROLYTIC CAP	0.47uF	50V	ケミコン	C409,410	
	VG290500	ELECTROLYTIC CAP	1uF	50V	ケミコン	C431,432	
	VF248700	ELECTROLYTIC CAP	1000uF	16V	ケミコン	C317,318	
	UK166100	ELECTROLYTIC CAP	1uF	50V	BPケミコン	C319,320	
	VL877300	CARBON RESISTOR	1KΩ	1/3W	カーボン抵抗	R325,326	
	VL877400	CARBON RESISTOR	1.2KΩ	1/3W	カーボン抵抗	R313,314	
	HV454100	FLAME PROOF CARBON RESISTOR	10Ω	1/4W	不燃化カーボン抵抗	R331,332	
	HV455100	FLAME PROOF CARBON RESISTOR	100Ω	1/4W	不燃化カーボン抵抗	R321-324,401,402	
	XA956A00	IC	NJH2068S		IC	IC401	
	KA805110	PUSH SWITCH	SUN192H		プッシュSW	SW402	
	KA805120	PUSH SWITCH	SUN192H		プッシュSW	SW401	
	VL542200	ROTARY SWITCH WITH MOTOR	SRBAA4G01A		モーター付ロータリーSW	SW301	
	VL542900	ROTARY SWITCH	SRRZ		ロータリーSW	SW302	
	VB858600	BASE PIN	PH L-TYPE	7P SE	ベースピン	CB304	
	VB858700	BASE PIN	PH	8P SE	ベースピン	CB303	
	LB919030	BASE PIN	XII L-TYPE	3P SE	ベース付ポスト	CB301	
	LB919070	BASE PIN	XII	7P SE	ベース付ポスト	CB302	
	VD004600	BASE PIN	PH	i-TYPE 3P TE	ベースピン	CB307	
	VD005000	BASE PIN	PH	i-TYPE 7P TE	ベースピン	CB305,401	
	V1009100	CONNECTOR	FPC	i-TYPE 17P TE	FPCコネクタ	CB306	
	VI379200	CONNECTOR	MQ	12P	コネクタソケット	CB308-310	
	VK314700	POTENTIOMETER	MN100KΩ		ロータリーVR	VR404	
	VK314800	POTENTIOMETER	30KΩ		ロータリーVR	VR403	
	VL543000	POTENTIOMETER	80KΩ		ロータリーVR	VR402	
	VL543100	POTENTIOMETER	100KΩ		ロータリーVR	VR401	
	VL545100	POTENTIOMETER WITH MOTOR	50K,10KΩ	LED	モーター付VR	VR301	
	IA101521	TRANSISTOR	2SA1015 Y		トランジスタ	Q303,304,307,308	
	IC1815C0	TRANSISTOR	2SC1815 Y		トランジスタ	Q305,306	
	IC224030	TRANSISTOR	2SC2240 GR,BL		トランジスタ	Q301,302	
	VK432900	TRANSISTOR	2SD1915 (F) ST		トランジスタ	Q309,310	

* : New Parts (新規部品)

ランク : Japan only

Ref. NO.	PART NO.	Description			部 品 名	Remarks	Markets	ランク
*	VL533000	MAIN CIRCUIT BOARD			メインシート		C	
*	VL533100	MAIN CIRCUIT BOARD			メインシート		R	
*	VL533200	MAIN CIRCUIT BOARD			メインシート		AB	
*	VL533300	MAIN CIRCUIT BOARD			メインシート		H	
*	VL533400	MAIN CIRCUIT BOARD			メインシート		W	
	VK984200	MYLAR FILM CAP	220pF	50V	マイラーコン	C604,609		
	FA154100	MYLAR FILM CAP	0.01uF	50V	マイラーコン	C680,681		
	UA252680	MYLAR FILM CAP	680pF	50V	マイラーコン	C613,614	CRABH	
	FA153100	MYLAR FILM CAP	1000pF	50V	マイラーコン	C613,614	W	
	VK533900	POLYPROPYLENE FILM CAP	100pF	200V	PPコン	C615,618,620,621		
	VK534000	POLYPROPYLENE FILM CAP	220pF	200V	PPコン	C678,679		
	UT453390	POLYPROPYLENE FILM CAP	3900pF	100V	PPコン	C650-653	W	
	VK534200	POLYPROPYLENE FILM CAP	0.022uF	100V	PPコン	C660,663	W	
	VK534400	POLYPROPYLENE FILM CAP	0.047uF	100V	PPコン	C640,643-647,667,668		
	FT174120	POLYPROPYLENE FILM CAP	0.012uF	100V	PPコン	C659,661,662,664	W	
	FG244100	CERAMIC CAP	0.01uF	50V	セラコン	C682		
	FG244220	CERAMIC CAP	0.022uF	50V	セラコン	C669	HW	
	FI504100	CERAMIC CAP	0.01uF	400V	スパークキラーコン	C677		
	UJ895220	ELECTROLYTIC CAP	0.22uF	100V	ケミコン	C642		
	VE016600	ELECTROLYTIC CAP	220uF	6.3V	ケミコン	C623		
	VE017800	ELECTROLYTIC CAP	47uF	16V	ケミコン	C601,610		
	VG287200	ELECTROLYTIC CAP	10uF	16V	ケミコン	C622,624,641,648		
	VG287600	ELECTROLYTIC CAP	100uF	16V	ケミコン	C631,649,674,675		
	VG290700	ELECTROLYTIC CAP	3.3uF	50V	ケミコン	C605,611,658		
	VI532800	ELECTROLYTIC CAP	47uF	16V	ケミコン	C603,608		
	VI532900	ELECTROLYTIC CAP	100uF	16V	ケミコン	C616,617		
	VK347900	ELECTROLYTIC CAP	470uF	63V	ケミコン	C619,671		
	VG289400	ELECTROLYTIC CAP	3300uF	25V	ケミコン	C656,657		
*	VL715300	ELECTROLYTIC CAP	14000uF	63V	ケミコン	C665,666		
	VI862200	POLYETHYLENE FILM CAP	0.1uF	100V	ポリエチレンコン	C672,673		
	FU451150	NICA CAP	15pF	500V	マイカコン	C606,607		
	VC793700	COIL	1.5uH		空芯コイル	L601,602		
	HV453100	FLAME PROOF CARBON RESISTOR	1Ω	1/4W	不燃化カーボン抵抗	R720,723		
	HV453220	FLAME PROOF CARBON RESISTOR	2.2Ω	1/4W	不燃化カーボン抵抗	R738		
	HV453220	FLAME PROOF CARBON RESISTOR	2.2Ω	1/4W	不燃化カーボン抵抗	R721,722	W	
	HV453220	FLAME PROOF CARBON RESISTOR	2.2Ω	1/4W	不燃化カーボン抵抗	R726	HW	
	HV453470	FLAME PROOF CARBON RESISTOR	4.7Ω	1/4W	不燃化カーボン抵抗	R680,681,688-693,700,701,708,711,716,718		
	HV454220	FLAME PROOF CARBON RESISTOR	22Ω	1/4W	不燃化カーボン抵抗	R646,733		
	HV454820	FLAME PROOF CARBON RESISTOR	82Ω	1/4W	不燃化カーボン抵抗	R640,652		
	HV455100	FLAME PROOF CARBON RESISTOR	100Ω	1/4W	不燃化カーボン抵抗	R605,622,645,647		
	HV455680	FLAME PROOF CARBON RESISTOR	680Ω	1/4W	不燃化カーボン抵抗	R644,648	CRABH	
	HV455330	FLAME PROOF CARBON RESISTOR	330Ω	1/4W	不燃化カーボン抵抗	R644,648	W	
	HV455220	FLAME PROOF CARBON RESISTOR	220Ω	1/4W	不燃化カーボン抵抗	R629-632,673,676		
	HV455560	FLAME PROOF CARBON RESISTOR	560Ω	1/4W	不燃化カーボン抵抗	R628,633		
	HV455820	FLAME PROOF CARBON RESISTOR	820Ω	1/4W	不燃化カーボン抵抗	R665,666		
	HV456270	FLAME PROOF CARBON RESISTOR	2.7KΩ	1/4W	不燃化カーボン抵抗	R660,671		
	HL323470	METAL OXIDE RESISTOR	4.7Ω	2W	酸化金属被膜抵抗	R709,710		
	HL325220	METAL OXIDE RESISTOR	220Ω	2W	酸化金属被膜抵抗	R731,732		
	HL325820	METAL OXIDE RESISTOR	820Ω	2W	酸化金属被膜抵抗	R702,703,713		

* : New Parts (新規部品)

ランク : Japan only

Ref. NO.	PART NO.	Description	部 品 名	Remarks	Markets	ランク
	VJ695400	WIRE WOUND RESISTOR	0.22Ω×2 3W	セメント抵抗	R683,684,697,698	
	VK877300	CARBON RESISTOR	1KΩ 1/3W	カーボン抵抗	R613,625	
	VL878500	CARBON RESISTOR	10KΩ 1/3W	カーボン抵抗	R739,740	
	VL862900	CARBON RESISTOR	47KΩ 1/3W	カーボン抵抗	R618,734	
	IG076800	IC	NJM4558S	IC	IC601	
	VD948800	PUSH SWITCH	TV-5	ブッシュSW	SW601	RABIW
	KA804300	PUSH SWITCH	FSB-99753V	ブッシュSW	SW601	C
	VA961800	VOLTAGE SELECTOR	ESE-37247-F	電圧切替器	SW602	R
*	VL544900	PUSH SWITCH	SPHL	ブッシュSW	SW603	
	VK475500	PUSH SWITCH	SPUH21	ブッシュSW	SW604	
*	KB000390	FUSE	T4.5A 250V	ヒューズ	F602	R
	VD370900	FUSE	10A 250V	ヒューズ	F601	C
	KB001490	FUSE	10A 250V	ヒューズ	F601	R
	KB003100	FUSE	T4.0A 250V	ヒューズ	F601	ABHW
	KC001940	RELAY	DH24D2-OT(H)	リレー	RY601,602	
	VK438300	RELAY	DH24D2-OT(H)-II	リレー	RY603	
*	VL920100	SPEAKER TERMINAL	T6489-A 8P	スピーカ端子	TE607	CRABW
*	VL920200	SPEAKER TERMINAL	T6492-A 8P	スピーカ端子	TE607	H
	LA002000	WRAPPING TERMINAL	2P i-TYPE P=7.5	ラッピング端子	TE603	
	LA002110	WRAPPING TERMINAL	2P i-TYPE P=5	ラッピング端子	TE604	HW
	LA002140	WRAPPING TERMINAL	2P i-TYPE P=10	ラッピング端子	TE601	
	LA002320	WRAPPING TERMINAL	3P i-TYPE P=7.5	ラッピング端子	TE602	
	LB301720	PHONES JACK	M1669-A	ホーンジャック	JK601	CR
	VI327500	AC OUTLET	3P	ACアウトレット	JK602	
	VE225700	BASE PIN	2P P=7.5	ベース付ポスト	TE606	RABIW
	VG879900	BASE PIN	VH 2P TE	ベースピン	TE608	C
	VA252300	CONNECTOR	MQ 5P	MQコネクタ	CB603	
	VB994900	CONNECTOR	MQ 9P	MQコネクタ	CB602	
	VI378000	BASE PIN	MQ 10P TE	ベースピン	CB601	
	VI378300	CONNECTOR	MQ 5P	コネクタソケット	CB608	
	VI378700	CONNECTOR	MQ 9P	コネクタソケット	CB606	
	VI378800	CONNECTOR	MQ 10P	コネクタソケット	CB607	
*	VK216100	PLUG	FJ 6P	FJ-L プラグ	CB617	
*	VK216900	CONNECTOR	FJ 6P	FJ-リセプタクル	CB615,616	
	VDO04600	BASE PIN	PH i-TYPE 3P TE	ベースピン	CB613	
	VB858200	BASE PIN	PH L-TYPE 3P SE	ベースピン	CB611	
	VL845300	BASE POST	XII 9P TE	ベース付ポスト	CB618	
	VJ692800	PRE-SET POTENTIOMETER	B470Ω	半固定VR	VR601,602	
	IA097000	TRANSISTOR	2SA970 GR,BL	トランジスタ	Q602,603,608,609,611,616,650	
	IA101521	TRANSISTOR	2SA1015 Y	トランジスタ	Q622,623,654	
	VL808200	TRANSISTOR	2SA1124 Q,R,S,T	トランジスタ	Q619,626	
	VC614000	TRANSISTOR	2SB1274 Q,R,S	トランジスタ	Q630	
	IC181500	TRANSISTOR	2SC1815 Y	トランジスタ	Q612-615,617,628	
	IC224030	TRANSISTOR	2SC2240 GR,BL	トランジスタ	Q629,651,652	
	IC260320	TRANSISTOR	2SC2603 E,F	トランジスタ	Q632,633	
	VL808300	TRANSISTOR	2SC2632 Q,R,S,T	トランジスタ	Q621,624	
	VC407900	TRANSISTOR	2SD1913 R,S	トランジスタ	Q653	
	VK432900	TRANSISTOR	2SD1915(F) ST	トランジスタ	Q601,604-607,610	
*	VL582500	TRANSISTOR	2SB1186A D,E	トランジスタ	Q636,637	

*: New Parts (新規部品)

ランク: Japan only

Ref. NO.	PART NO.	Description	部 品 名	Remarks	Markets	ランク
*	VL582600	TRANSISTOR	2SD1763A D,E	トランジスタ	Q635,638	
*	VL542700	DIGITAL TRANSISTOR	DTA123JS	デジタルトランジスタ	Q639,648,649	
	1F004600	DIODE	1SS133	ダイオード	D601-607,614,615, 622-624,635,636	
	VC308400	DIODE	MA185	ダイオード	D627,629,630	
	VH770800	DIODE	1SR139-100 T-32	ダイオード	D631-634	
	VH702000	DIODE BRIDGE	S5VB20 3.5A 200V	ダイオードブリッジ	D628	
	VG441200	ZENER DIODE	MTZJ16C	ツェナーダイオード	D617,625	
*	VL448600	JUMPER		ラジアルジャンパー線	J951,952	
	LB201880	FUSE HOLDER PIN	PC-FH1	ヒューズホルダーピン		
	VB966900	PIN	1MSA-6024	スタイルピン		
	BB071360	SCREW TERMINAL	8.3x13	ネジ端子		
	VE808500	SCREW TERMINAL	φ4	ネジ端子		
	VL800500	HEAT SINK	T220H31-30	ヒートシンク		
*	EX602250	BIND HEAD SENS SCREW	3x12 ZMC2-BL	セムスパインド小ネジ		
	CB644670	COVER, CAPACITOR		コンデンサカバー		

* : New Parts (新規部品)

ランク : Japan only

AX-750

EXPLODED VIEW

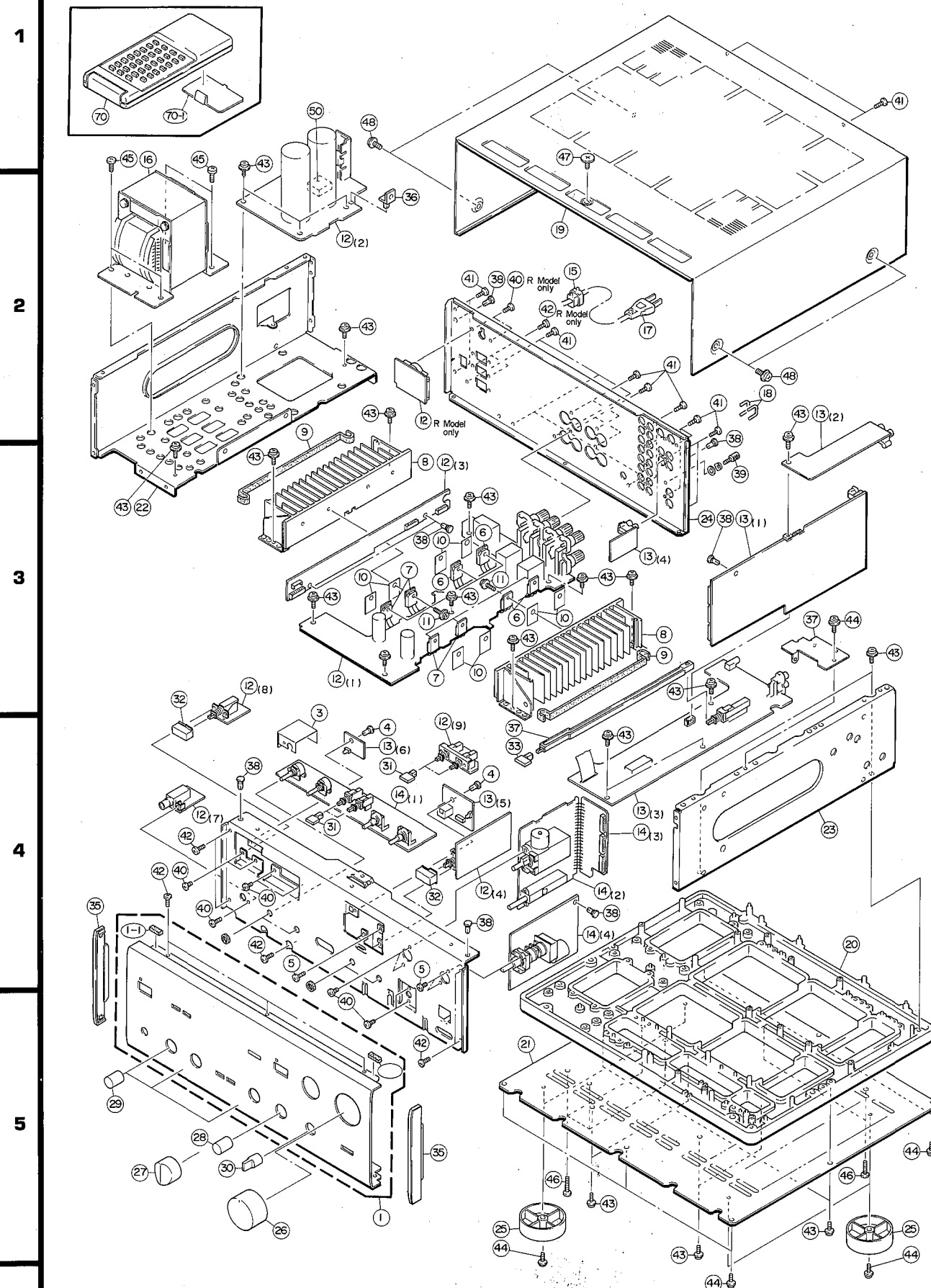

PARTS LIST

Ref. NO.	PART NO.	Description	部品名	Remarks	Markets	ラック
* 1	VL532600	PANEL UNIT	パネルユニット	BL		
* 1	VL532700	PANEL UNIT	パネルユニット	T		
1-1	VE222600	CUSHION	クッション			
2	VL213500	SUB CHASSIS	サブシャーシ			
3	VL549200	SHEET, SHIELD	シート シールド			
4	CB605620	PLASTIC RIVET	プラスチックリベット	NO.1057		
5	ED330066	BIND HEAD SCREW	バインド小ネジ	3x6 FCRM3-BL	PACK	
6	IX609730	TRANSISTOR	トランジスタ	2SA1491 O.P.Y	QG42-645	
7	IX609740	TRANSISTOR	トランジスタ	2SC3855 O.P.Y	QG40, 641, 646, 647	
* 8	VL212700	RADIATOR ASS'y	ラジエーターASSY			
* 9	VK706700	DAMPER, FIN	ダンパー/FIN			
10	VK195900	SHEET	シート	19x24		
11	VK173200	SCREW, TRANSISTOR	スクリーTR			
* 12	VL533000	MAIN CIRCUIT BOARD	メインシート		C	
* 12	VL533100	MAIN CIRCUIT BOARD	メインシート		R	
* 12	VL533200	MAIN CIRCUIT BOARD	メインシート		AB	
* 12	VL533300	MAIN CIRCUIT BOARD	メインシート		H	
* 12	VL533400	MAIN CIRCUIT BOARD	メインシート		W	
* 13	VL533600	FUNCTION CIRCUIT BOARD	ファンクションシート			
* 14	VL533800	TONE CONTROL CIRCUIT BOARD	トーンコントロールシート			
15	VD778200	CORD STOPPER	コードストッパー		C	
15	VD375900	CORD STOPPER	コードストッパー		RABHW	
* 16	XJ693800	POWER TRANSFORMER	電源トランス		C	
* 16	XJ694A00	POWER TRANSFORMER	電源トランス		R	
* 16	XJ695A00	POWER TRANSFORMER	電源トランス		AB	
* 16	XJ696A00	POWER TRANSFORMER	電源トランス		HW	
17	VL012900	POWER CORD ASS'y	パワーコードASSY		C	
17	VE222900	POWER CORD ASS'y	パワーコードASSY		R	
17	VE042900	POWER CORD ASS'y	パワーコードASSY		A	
17	VK815600	POWER CORD ASS'y	パワーコードASSY		B	
17	VE223200	POWER CORD ASS'y	パワーコードASSY		HW	
18	LB101110	SHORT PIN	ショートピン			
* 19	VL212800	TOP COVER	トップカバー	BL		
* 19	VL213000	TOP COVER	トップカバー	T		
* 20	VL213100	CHASSIS	シャーシ/アートベース			
* 21	VL213600	BOTTOM COVER	ボトムカバー			
* 22	VL213700	FRAME	フレーム/サイド	SIDE L		
* 23	VL213800	FRAME	フレーム/サイド	SIDE R		
* 24	VL250100	REAR PANEL	リヤパネル		C	
* 24	VL214200	REAR PANEL	リヤパネル		R	
* 24	VL214300	REAR PANEL	リヤパネル		AB	
* 24	VL214400	REAR PANEL	リヤパネル		W	
* 24	VL507700	REAR PANEL	リヤパネル		H	
25	VI615200	LEG	レッグ			
26	VK015100	KNOB	ノブ	VOLUME	BL	
26	VK015200	KNOB	ノブ	VOLUME	T	
27	VK219900	KNOB	ノブ	INPUT	BL	
27	VK220000	KNOB	ノブ	INPUT	T	
28	VK232700	KNOB	ノブ	LOUDNESS	BL	
28	VK232800	KNOB	ノブ	LOUDNESS	T	

* : New Parts (新規部品)

ラック : Japan only

Ref NO.	PART NO.	Description	部品名	Remarks	Markets	ランク
29	VK232500	KNOB	BALANCE	ノブ	BL	
29	VK232600	KNOB	BALANCE	ノブ	T	
30	VK865500	KNOB	REC OUT	ノブ	BL	
30	VK865600	KNOB	REC OUT	ノブ	T	
31	VH816000	BUTTON	SPEAKERS	ボタン	BL	
31	VH816100	BUTTON	SPEAKERS	ボタン	T	
32	VH841900	BUTTON	POWER	ボタン		
32	VH842000	BUTTON	POWER	ボタン		
33	VH816200	BUTTON	PHONO	ボタン	BL	
33	VH816300	BUTTON	PHONO	ボタン	T	
* 34	VL250500	EXTENSION BAR		ロッド		
35	VJ833000	SIDE COVER		サイドカバー	T	
35	VJ833100	SIDE COVER		サイドカバー	BL	
36	CB091290	P.C.B SUPPORT	NO. 1645	基板サポート		
* 37	VL215000	FRAME	PCB2	フレーム/PCB2		
38	CB068880	PLASTIC RIVET	NO. 1027	プラスチックリベット		
39	AA627310	GROUND TERMINAL		GNDターミナル		
40	ED330066	BIND HEAD SCREW	3x6 FCRH3-BL	バインド小ネジ		
41	EN301010	BIND HEAD BONDING TAP, SCREW	3x8 FCRH3-BL	ボンディングBタイトネジ		
42	EI330086	BIND HEAD B-TITE SCREW	3x8 FCRH3-BL	バインドBタイトネジ		
43	VB770200	BW HEAD P-TITE SCREW	3x10-8 FCRH3	BWヘッドPタイトネジ		
44	EK330030	BW HEAD TAPPING SCREW	3x10 FCRH3-BL	BWヘッドタッピングネジ		
45	EN330060	BIND HEAD B-TITE SCREW	4x16 FCRH3-BL	バインドBタイトネジ		
46	VB569300	BIND HEAD TAPPING SCREW	4x25 FCRH3-BL	バインドBタイトネジ		
47	EX601850	SPECIAL SCREW S-TITE	4x8-10 FCRH3-BL	化粧ネジSタイト	BL	
47	EX601860	SPECIAL SCREW S-TITE	4x8-10 FNM3-BL	化粧ネジSタイト	T	
48	EK365090	BW HEAD SCREW	4x8 ZMC2-BL	BWヘッドSタイトネジ	BL	
48	EX601150	BW HEAD S-TITE SCREW	4x8-10 FNM3-BL	BWヘッドSタイトネジ	T	
49	CB091290	P.C.B SUPPORT	NO. 1645	基板サポート		
50	CB642050	DAMPER		ダンパー		CR
	CB069251	BINDING TIE	BK-1	束線止め		HW
ACCESSORIES						
* 70	VL208500	REMOTE CONTROL TRANSMITTER	SBAH00287A	リモコントランスミッター		
70-1	XX671360	LID		電池蓋		
		DRY CELL	SUN-3,AA	マンガン電池		

* : New Parts (新規部品)

ランク : Japan only

REMOTE CONTROL TRANSMITTER

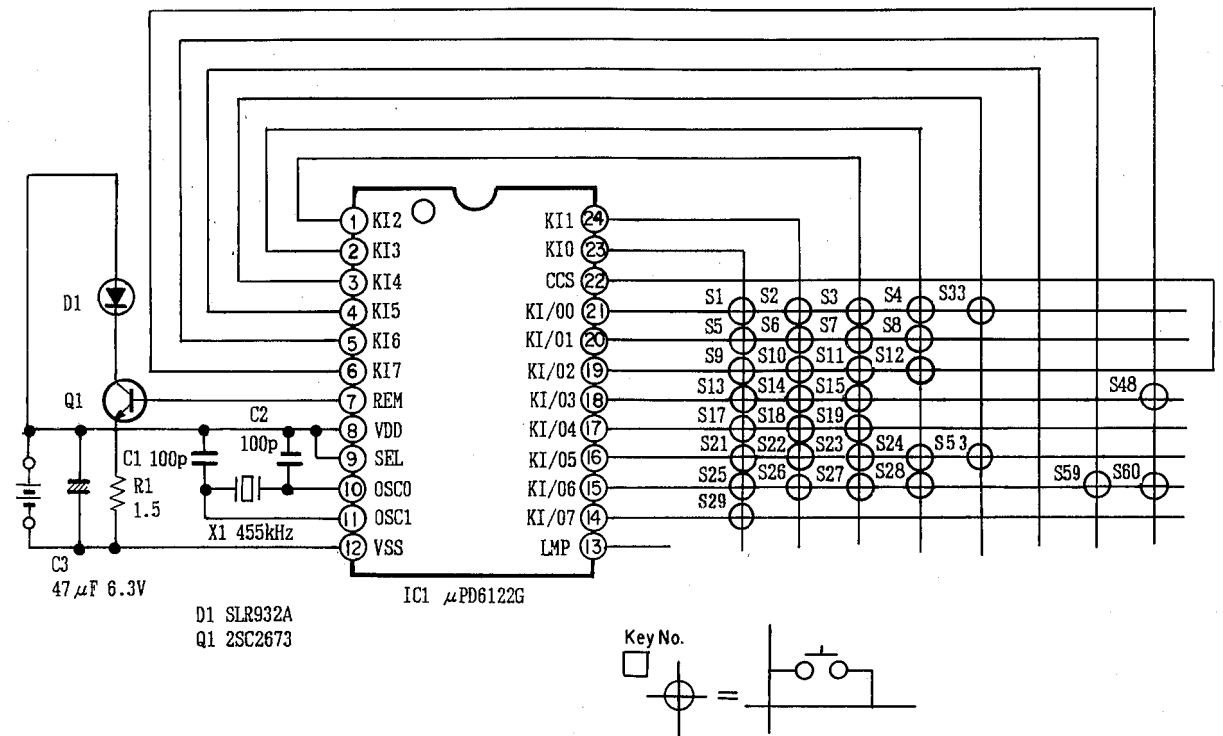

KEY NO.	DATA CODE								FUNCTION
	D0	D1	D2	D3	D4	D5	D6	D7	
1	0	0	0	0	0	0	0	0	PLAY
2	1	0	0	0	0	0	0	0	◀◀
3	0	1	0	0	0	0	0	0	▶▶
4	1	1	0	0	0	0	0	0	STOP
5	0	0	1	0	0	0	0	0	REC/PAUSE
6	1	0	1	0	0	0	0	0	REC MUTE
7	0	1	1	0	0	0	0	0	DECK A/B
8	1	1	1	0	0	0	0	0	DIR A
9	0	0	0	1	0	0	0	0	PLAY (CD)
10	1	0	0	1	0	0	0	0	PAUSE/STOP
11	0	1	0	1	0	0	0	0	SKIP ▶▶
12	1	1	0	1	0	0	0	0	SKIP ◀◀
13	0	0	1	1	0	0	0	0	SEARCH ▶▶
14	1	0	1	1	0	0	0	0	SEARCH ◀◀
15	0	1	1	1	0	0	0	0	PLAY/CUT
17	0	0	0	0	1	0	0	0	PRESET +
18	1	0	0	0	1	0	0	0	PRESET -
19	0	1	0	0	1	0	0	0	A/B/C/D/E
21	0	0	1	0	1	0	0	0	PHONO
22	1	0	1	0	1	0	0	0	CD
23	0	1	1	0	1	0	0	0	TUNER
24	1	1	1	0	1	0	0	0	AUX
25	0	0	0	1	1	0	0	0	TAPE1
26	1	0	0	1	1	0	0	0	TAPE2
27	0	1	0	1	1	0	0	0	VOLUME +
28	1	1	0	1	1	0	0	0	VOLUME -
29	0	0	1	1	1	0	0	0	MUTING -20 dB
33	0	0	0	0	0	0	1	0	DIR B
48	1	1	1	1	0	0	1	0	DISC SKIP
53	0	0	1	0	1	0	1	0	DAT
59	0	1	0	1	1	0	1	0	EQ ON/FLAT
60	1	1	0	1	1	0	1	0	EQ PRESET SKIP
CUSTOM CODE	0	1	0	1	1	1	1	0	

Parts List for Carbon Resistors

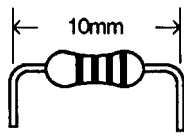
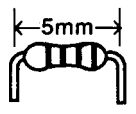
Value	1/4W Type Part No.	1/6W Type Part No.	Value	1/4W Type Part No.	1/6W Type Part No.
1.0 Ω	HJ35 3100	HF853100	12 KΩ	HJ35 7120	HF85 7120
1.8 Ω	HJ35 3180	*	15 KΩ	HJ35 7150	HF85 7150
2.2 Ω	HJ35 3220	HF853220	18 KΩ	HJ35 7180	HF85 7180
3.3 Ω	HJ35 3330	HF853330	22 KΩ	HJ35 7220	HF85 7220
4.7 Ω	HJ35 3470	HF853470	27 KΩ	HJ35 7270	HF85 7270
5.6 Ω	HJ35 3560	HF853560	33 KΩ	HJ35 7330	HF85 7330
10 Ω	HJ35 4100	HF85 4100	39 KΩ	HJ35 7390	HF85 7390
15 Ω	HJ35 4150	HF85 4150	47 KΩ	HJ35 7470	HF85 7470
22 Ω	HJ35 4220	HF85 4220	56 KΩ	HJ35 7560	HF85 7560
27 Ω	HJ35 4270	HF85 4270	68 KΩ	HJ35 7680	HF85 7680
33 Ω	HJ35 4330	HF85 4330	82 KΩ	HJ35 7820	HF85 7820
39 Ω	HJ35 4390	HF85 4390	91 KΩ	HJ35 7910	HF85 7910
47 Ω	HJ35 4470	HF85 4470	100 KΩ	HJ35 8100	HF85 8100
56 Ω	HJ35 4560	HF85 4560	120 KΩ	HJ35 8120	HF85 8120
68 Ω	HJ35 4680	HF85 4680	150 KΩ	HJ35 8150	HF85 8150
82 Ω	HJ35 4820	HF85 4820	180 KΩ	HJ35 8180	HF85 8180
100 Ω	HJ35 5100	HF85 5100	220 KΩ	HJ35 8220	HF85 8220
110 Ω	HJ35 5110	HF85 5110	270 KΩ	HJ35 8270	HF85 8270
120 Ω	HJ35 5120	HF85 5120	330 KΩ	HJ35 8330	HF85 8330
150 Ω	HJ35 5150	HF85 5150	390 KΩ	HJ35 8390	HF85 8390
160 Ω	HJ35 5160	*	470 KΩ	HJ35 8470	HF85 8470
180 Ω	HJ35 5180	HF85 5180	560 KΩ	HJ35 8560	HF85 8560
220 Ω	HJ35 5220	HF85 5220	680 KΩ	HJ35 8680	HF85 8680
270 Ω	HJ35 5270	HF85 5270	820 KΩ	HJ35 8820	HF85 8820
330 Ω	HJ35 5330	HF85 5330	1.0 MΩ	HJ35 9100	HF85 9100
390 Ω	HJ35 5390	HF85 5390	1.2 MΩ	HJ35 9120	*
470 Ω	HJ35 5470	HF85 5470	1.5 MΩ	HJ35 9150	HF85 9150
510 Ω	*	HF85 5510	1.8 MΩ	HJ35 9180	HF85 9180
560 Ω	HJ35 5560	HF85 5560	2.2 MΩ	HJ35 9220	HF85 9220
680 Ω	HJ35 5680	HF85 5680	3.3 MΩ	HJ35 9330	HF85 9330
820 Ω	HJ35 5820	HF85 5820	3.9 MΩ	HJ35 9390	*
910 Ω	HJ35 5910	HF85 5910	4.7 MΩ	HJ35 9470	HF85 9470
1.0 KΩ	HJ35 6100	HF85 6100			
1.2 KΩ	HJ35 6120	HF85 6120			
1.5 KΩ	HJ35 6150	HF85 6150			
1.8 KΩ	HJ35 6180	HF85 6180			
2.0 KΩ	HJ35 6200	HF85 6200			
2.2 KΩ	HJ35 6220	HF85 6220			
2.4 KΩ	HJ35 6240	HF85 6240			
2.7 KΩ	HJ35 6270	HF85 6270			
3.0 KΩ	HJ35 6300	HF85 6300			
3.3 KΩ	HJ35 6330	HF85 6330			
3.6 KΩ	HJ35 6360	HF85 6360			
3.9 KΩ	HJ35 6390	HF85 6390			
4.7 KΩ	HJ35 6470	HF85 6470			
5.1 KΩ	HJ35 6510	HF85 6510			
5.6 KΩ	HJ35 6560	HF85 6560			
6.8 KΩ	HJ35 6680	HF85 6680			
8.2 KΩ	HJ35 6820	HF85 6820			
9.1 KΩ	HJ35 6910	HF85 6910			
10 KΩ	HJ35 7100	HF85 7100			
				<p>1/4W Type</p> <p>HJ35 ○○○○</p> 	<p>1/6W Type</p> <p>HF85 ○○○○</p> 

AX-750

AX-750

AX-750

YAMAHA

AX-750