

BLU-RAY DISC HOME THEATER SYSTEM BDX-610 BLU-RAY DISC RECEIVER / SPEAKERS BRX-610 / NS-PZ20

SERVICE MANUAL

The BDX-610 consists of the BRX-610 and NS-PZ20.
The NS-PZ20 consists of the NS-B20, NS-C20 and NS-SWP20.

* When the MAIN P.C.B. is replaced, the serial number and new MAC address MUST be reported to Yamaha Corporation by e-mail.

E-mail: ycav-keycontrol@gmx.yamaha.com

For more information, refer to "SERVICE PRECAUTIONS".

IMPORTANT NOTICE

This manual has been provided for the use of authorized YAMAHA Retailers and their service personnel. It has been assumed that basic service procedures inherent to the industry, and more specifically YAMAHA Products, are already known and understood by the users, and have therefore not been restated.

WARNING: Failure to follow appropriate service and safety procedures when servicing this product may result in personal injury, destruction of expensive components, and failure of the product to perform as specified. For these reasons, we advise all YAMAHA product owners that any service required should be performed by an authorized YAMAHA Retailer or the appointed service representative.

IMPORTANT: The presentation or sale of this manual to any individual or firm does not constitute authorization, certification or recognition of any applicable technical capabilities, or establish a principle-agent relationship of any form.

The data provided is believed to be accurate and applicable to the unit(s) indicated on the cover. The research, engineering, and service departments of YAMAHA are continually striving to improve YAMAHA products. Modifications are, therefore, inevitable and specifications are subject to change without notice or obligation to retrofit. Should any discrepancy appear to exist, please contact the distributor's Service Division.

WARNING: Static discharges can destroy expensive components. Discharge any static electricity your body may have accumulated by grounding yourself to the ground buss in the unit (heavy gauge black wires connect to this buss).

IMPORTANT: Turn the unit OFF during disassembly and part replacement. Recheck all work before you apply power to the unit.

CONTENTS

TO SERVICE PERSONNEL	2-4	DISASSEMBLY PROCEDURES	21-23
PREVENTION OF ELECTROSTATIC DISCHARGE	5	REWRITING OPU PARAMETER	24-30
REGION MANAGEMENT INFORMATION	6	SELF-DIAGNOSTIC FUNCTION	31-33
SYSTEM COMPOSITION	7	BLOCK DIAGRAM	35
FRONT PANELS	8	WIRING DIAGRAM	36
REAR PANELS	9-10	PRINTED CIRCUIT BOARDS	37-39
REMOTE CONTROL PANELS	11	SCHEMATIC DIAGRAMS	40-56
SPECIFICATIONS	12-17	REPLACEMENT PARTS LIST	58-60
INTERNAL VIEW	18	REMOTE CONTROL	61-62
SERVICE PRECAUTIONS	19-20	SOFTWARE UPGRADE	63



このサービスマニュアルは、エコマーク認定の再生紙を使用しています。
This Service Manual uses recycled paper.

SYSTEM COMPOSITION

The BDX-610 consists of the BRX-610 and NS-PZ20.
The NS-PZ20 consists of the NS-B20, NS-C20 and NS-SWP20.

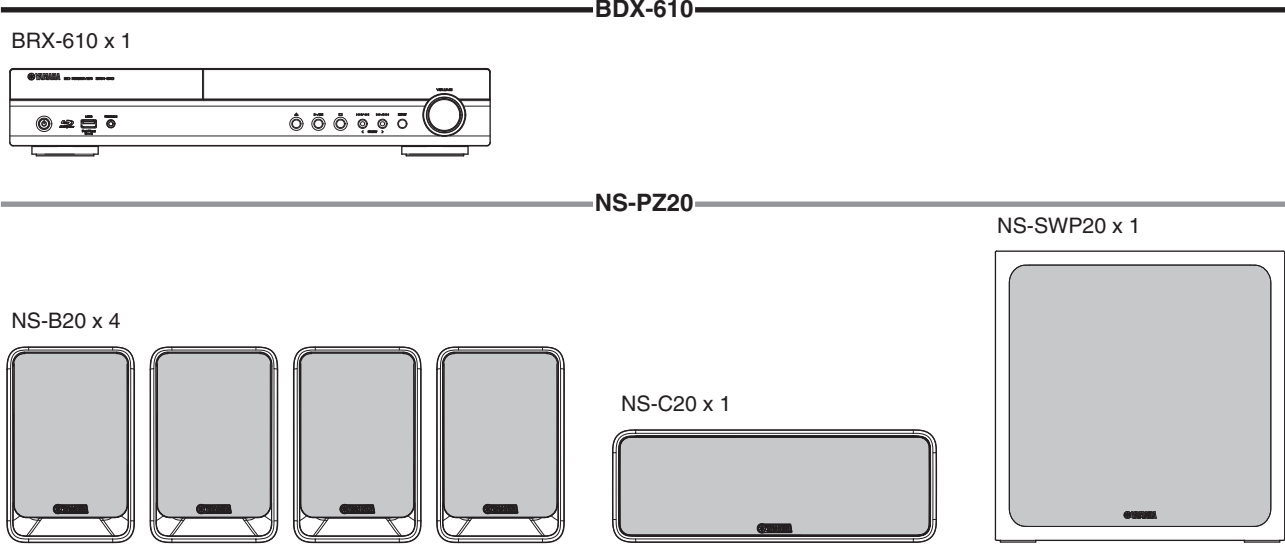

BRX-610/NS-PZ20

FRONT PANELS

BRX-610

U, C, T, G, F, L models

U, C, T, G, F, L models

HDMI AVCHD Blu-ray Disc Dolby Digital DTS-LPCM USB MP3 AAC-LC Live 3D

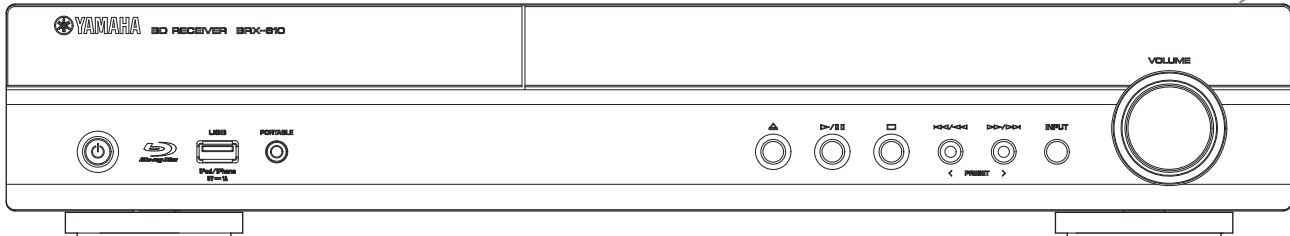

NS-PZ20

NS-B20

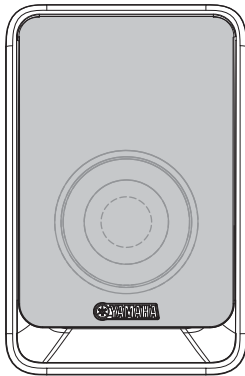

NS-C20

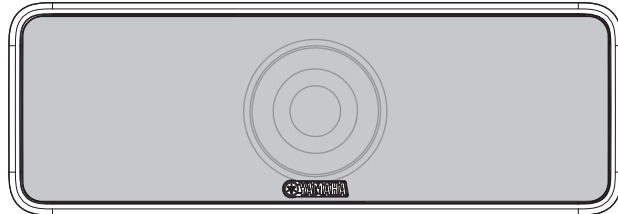

NS-SWP20

Front view

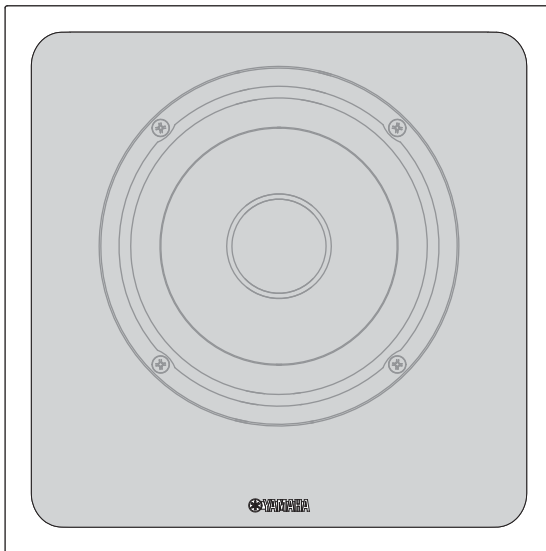

Side view

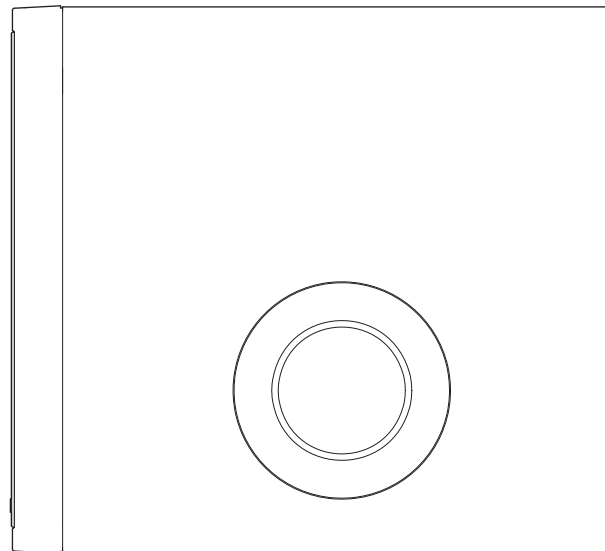

REAR PANELS

BRX-610

U, C models

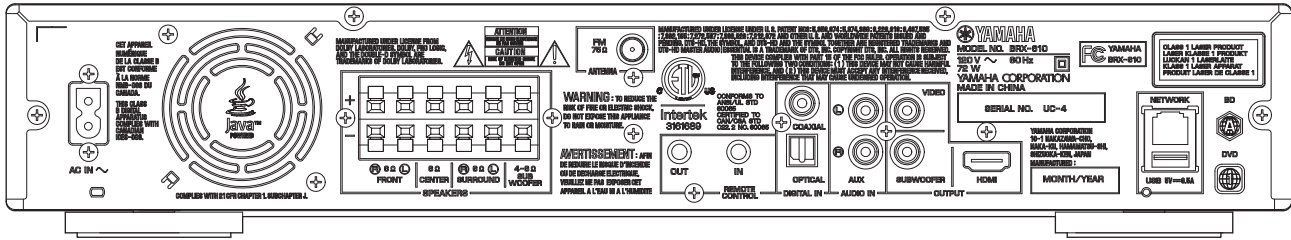

T model

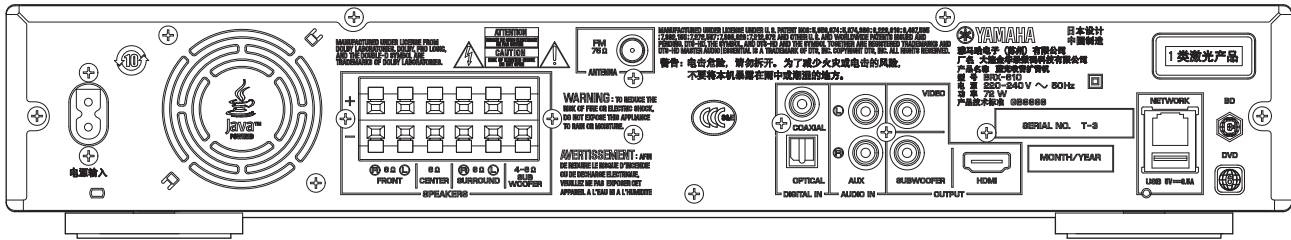

G model

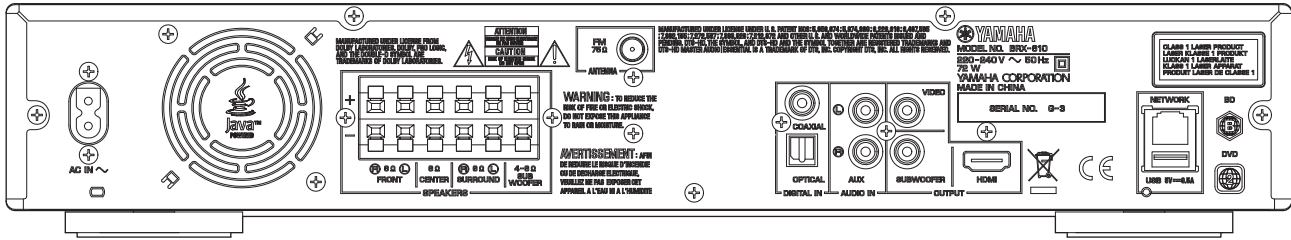

F model

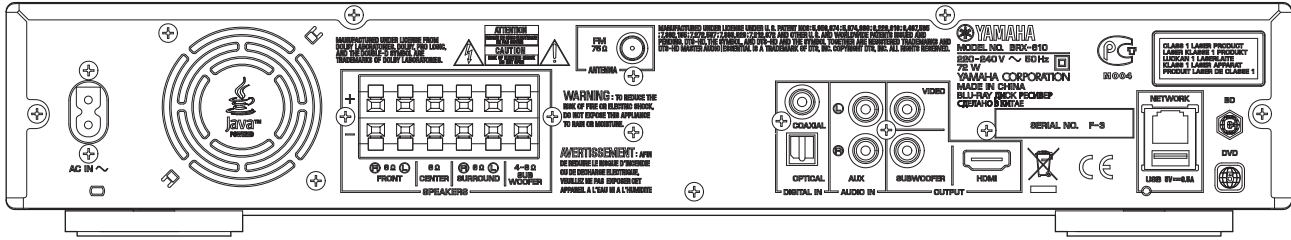

L model

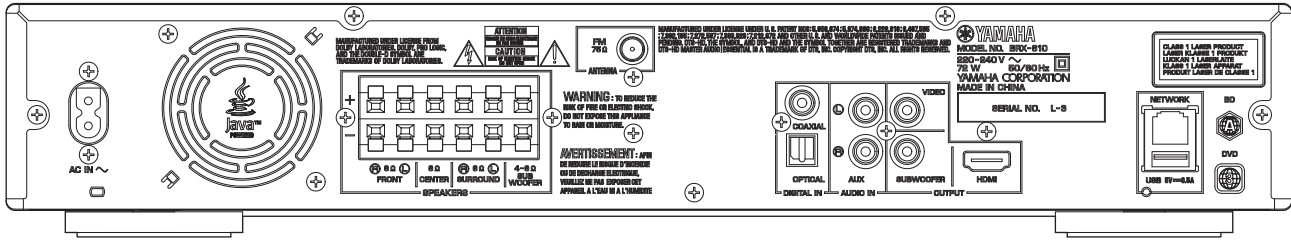

BRX-610/NS-PZ20

NS-PZ20

NS-B20

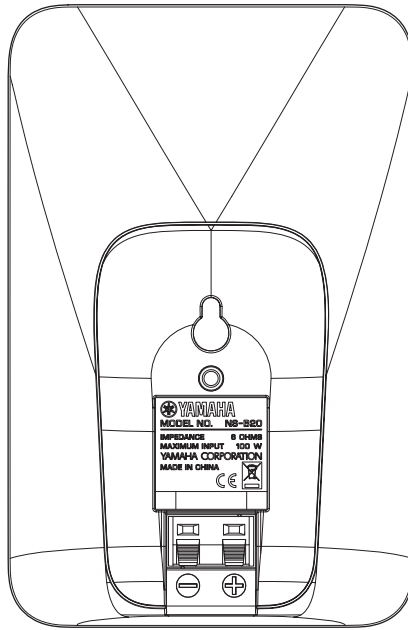

NS-C20

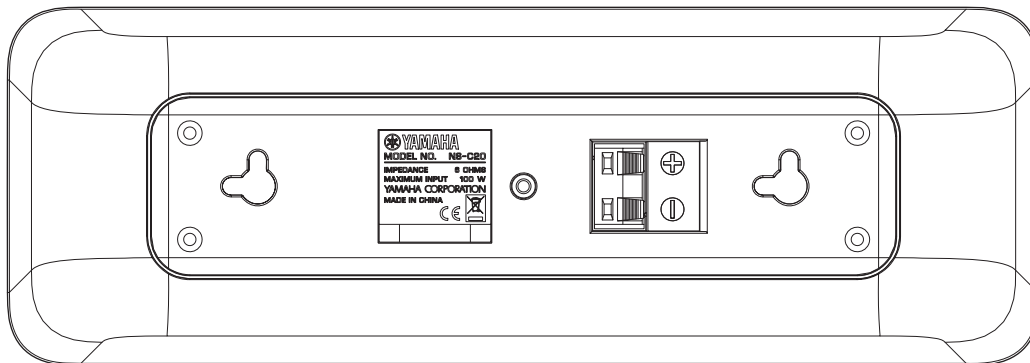

NS-SWP20

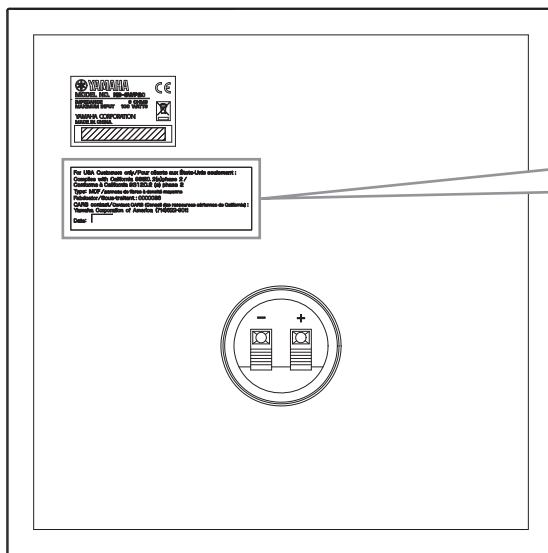

U model

For USA Customers only/Pour clients aux États-Unis seulement :
 Complies with California §320.2(a) phase 2 /
 Conforme à California §3120.2 (a) phase 2
 Type: MDF / panneau de fibres à densité moyenne
 Fabricator/Sous-traitant : 0000038
 CARB contact/Contact CARB (Conseil des ressources aériennes de Californie) :
 Yamaha Corporation of America (714)622-9011
 Date: _____

REMOTE CONTROL PANELS

671B92-7

(U, C, T, L models)

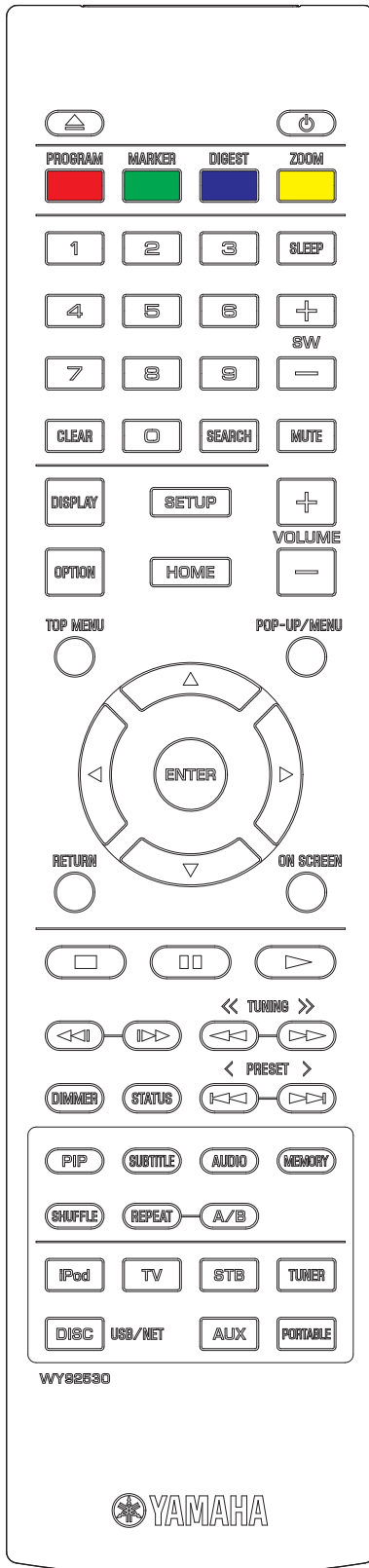

PROGRAM: Red
 MARKER: Green
 DIGEST: Blue
 ZOOM: Yellow

671B92-6

(G, F models)

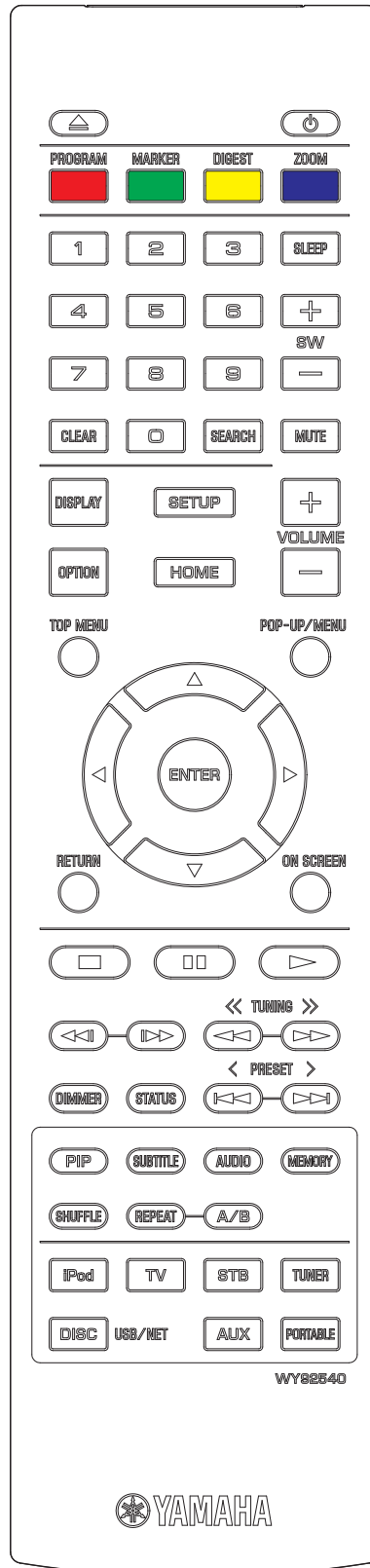

PROGRAM: Red
 MARKER: Green
 DIGEST: Yellow
 ZOOM: Blue

BRX-610/NS-PZ20

■ SPECIFICATIONS

BRX-610

■ Player Section

iPod/iPhone

Supported iPod

..... iPod classic
 iPod nano (2nd, 3rd, 4th, 5th and 6th generation)
 iPod touch (1st, 2nd, 3rd and 4th generation)

Supported iPhone

..... iPhone, iPhone 3G, iPhone 3GS, iPhone 4

AUX IN

Input terminal

AUX RCA
 STEREO L/R 3.5 mm (1/8") STEREO mini jack

■ Amplifier Section

Maximum Output Power (10 % THD)

FRONT L/R (1 kHz, 6 ohms) 80 W + 80 W
 CENTER (1 kHz, 6 ohms) 80 W
 SURROUND L/R (1 kHz, 6 ohms) 80 W + 80 W
 SUBWOOFER (100 Hz, 4 ohms) 100 W

Input Sensitivity/Input Impedance

AUX 200 mV / 47 k-ohms
 PORTABLE 100 mV / 47 k-ohms

Total Harmonic Distortion

AUX (1 kHz, 10 W) 0.05 %

■ FM Tuner Section

Tuning Range

U model 87.5 to 107.9 MHz
 C, T, G, F, L models 87.50 to 108.00 MHz

■ Input/Output Section

HDMI Output Terminal

..... Type A connector x 1
 480i/576i/480p/576p/720p/1080i/1080p/1080p/24Hz
 Deep Color, 3D, ARC (Audio Return Channel) support

Video Output

..... 1 Vp-p (75 ohms)

Digital Input

..... OPTICAL x 1
 COAXIAL x 1

USB Terminal

..... Type A connector x 2

Ethernet

..... 100 BASE-TX

Other Output Terminal [U, C models]

..... REMOTE CONTROL IN/OUT x 1

■ General

Power Supply

U, C models AC 120 V, 60 Hz
 T model AC 220 V, 50 Hz
 G model AC 220–240 V, 50 Hz
 F, L models AC 220–240 V, 50/60 Hz

Power Consumption 72 W

Standby Power Consumption 0.5 W or less

Dimensions (W x H x D)

..... 435 x 80 x 362 mm (17-1/8" x 3-1/8" x 14-1/4")

Weight 4.5 kg (9.9 lbs.)

Finish

U, C, T, G, F, L models Black color

Accessories

Remote control x 1
 Battery (R03, AAA, UM-4) x 2
 IndoorFM antenna (1.4 m) x 1
 Composite video cable (1.5 m) x 1
 Power cable (1.5 m) x 1

* Specifications are subject to change without notice.

U U.S.A. model G European model
 C Canadian model F Russian model
 T Chinese model L Singapore model

– iPhone, iPod, iPod classic, iPod nano, and iPod touch are trademarks of Apple Inc., registered in the U.S. and other countries.

– Audio-visual material may consist of copyrighted works which must not be recorded without the authority of the owner of the copyright. Refer to relevant laws in your country.

– This product incorporates copyright protection technology that is protected by U.S. patents and other intellectual property rights. Use of this copyright protection technology must be authorized by Rovi Corporation, and is intended for home and other limited viewing uses only unless otherwise authorized by Rovi Corporation. Reverse engineering or disassembly is prohibited.

– This product is licensed under the AVC patent portfolio license and VC-1 patent portfolio license for the personal and noncommercial use of a consumer to (i) encode video in compliance with the AVC Standard and VC-1 Standard ("AVC/VC-1 Video") and/or (ii) decode AVC/VC-1 Video that was encoded by a consumer engaged in a personal and non-commercial activity and/or was obtained from a video provider licensed to provide AVC/VC-1 Video. No license is granted or shall be implied for any other use. Additional information may be obtained from MPEG LA, LLC.

– Windows Media Player is a registered trademark or trademark of Microsoft corporation in the United States and/or other countries.

– YouTube and the YouTube logo are trademarks of Google, Inc.

– Netflix and the Netflix logo are the registered trademarks of Netflix, Inc.



– DVD is a trademark of DVD Format/Logo Licensing Corporation.



– Manufactured under license from Dolby Laboratories. Dolby, Pro Logic and the double-D symbol are trademarks of Dolby Laboratories.



– DTS-HD, the Symbol, & DTS-HD and the Symbol together are registered trademarks & DTS-HD Master Audio | Essential is a trademark of DTS, Inc. Product includes software. © DTS, Inc. All Rights Reserved.



BONUS VIEW™

- “Blu-ray Disc™”, “Blu-ray™”, “Blu-ray 3D™”, “BD-Live™”, “BONUSVIEW™”, and the logos are trademarks of the Blu-ray Disc Association.



HIGH-DEFINITION MULTIMEDIA INTERFACE

- HDMI, the HDMI logo and High-Definition Multimedia Interface are trademarks or registered trademarks of HDMI Licensing LLC.

x.v.Color

- “x.v.Color” and “x.v.Color” logo are trademarks.



- “AVCHD” and the “AVCHD” logo are trademarks of Panasonic Corporation and Sony Corporation.



- Java and all Java-based trademarks and logos are trademarks or registered trademarks of Sun Microsystems, Inc. in the United States and/or other countries.



- DLNA and DLNA CERTIFIED are trademarks and/or service marks of Digital Living Network Alliance.

NS-PZ20

■ NS-B20/NS-C20

Type Full-range acoustic suspension speaker system
Non-magnetic shielding type

Driver

Full-range 7 cm (2-3/4") cone type x 1

Frequency Response

[NS-B20] 70 Hz to 25 kHz (-10 dB)
to 45 kHz (-30 dB)

[NS-C20] 65 Hz to 25 kHz (-10 dB)
to 45 kHz (-30 dB)

Impedance 6 ohms

Nominal Input 30 W

Maximum Input 100 W

Sensitivity

[NS-B20] 83 dB/2.83 V/m

[NS-C20] 84 dB/2.83 V/m

Input Terminal Push type

Dimensions (W x H x D)

[NS-B20] 115 mm x 176 mm x 88 mm
(4-1/2" x 6-7/8" x 3-1/2")

[NS-C20] 291 mm x 101 mm x 103 mm
(11-1/2" x 4" x 4")

Weight

[NS-B20] 0.48 kg (1.06 lbs.)

[NS-C20] 0.68 kg (1.50 lbs.)

■ NS-SWP20

Type Bass reflex speaker system
Non-magnetic shielding type

Driver

Subwoofer 16 cm (6-1/2") cone type x 1

Frequency Response 30 Hz to 2 kHz (-10 dB)
to 9 kHz (-30 dB)

Impedance 6 ohms

Nominal Input 30 W

Maximum Input 100 W

Sensitivity 86 dB/2.83 V/m

Input Terminal Push type

Dimensions (W x H x D)

..... 262 mm x 264 mm x 287 mm
(10-3/8" x 10-3/8" x 11-1/4")

Weight 5.2 kg (11.5 lbs.)

■ General

Finish

U, C, T, G, F, L models Black color

Accessory

Speaker cable (25 m) x 1

Nonskid pad (NS-B20/NS-C20) x 24

* Specifications are subject to change without notice.

U *U.S.A. model*

G *European model*

C *Canadian model*

F *Russian model*

T *Chinese model*

L *Singapore model*

• DIMENSIONS

BRX-610

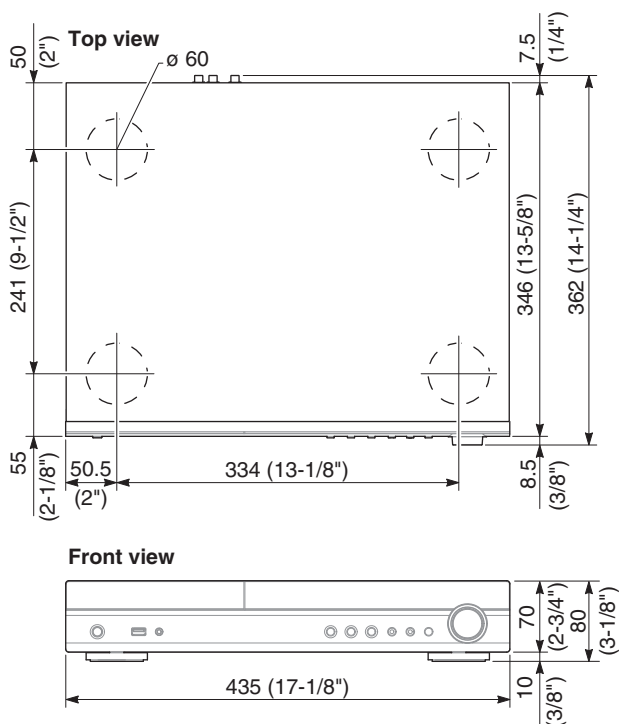

Unit: mm (inch)

NS-PZ20

▼ **NS-B20**

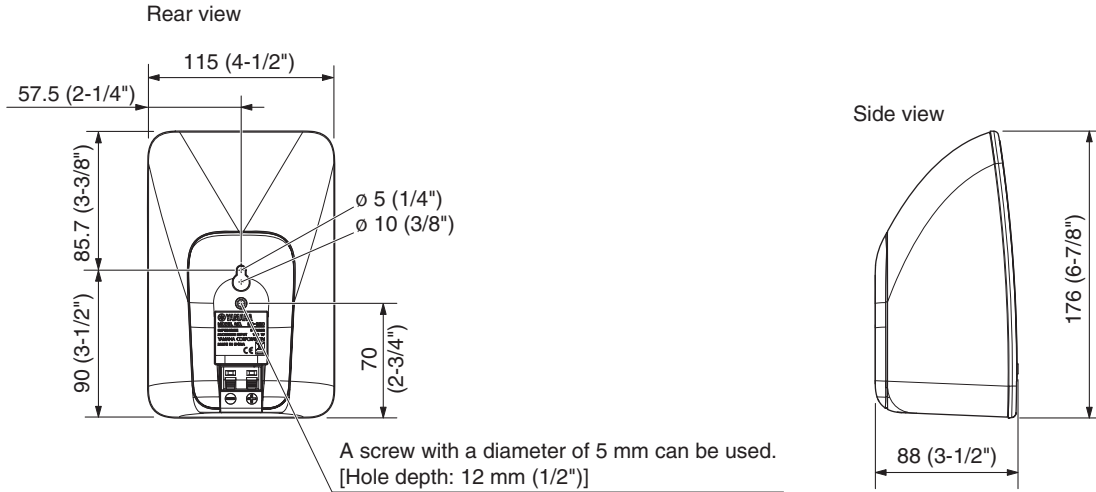

▼ **NS-C20**

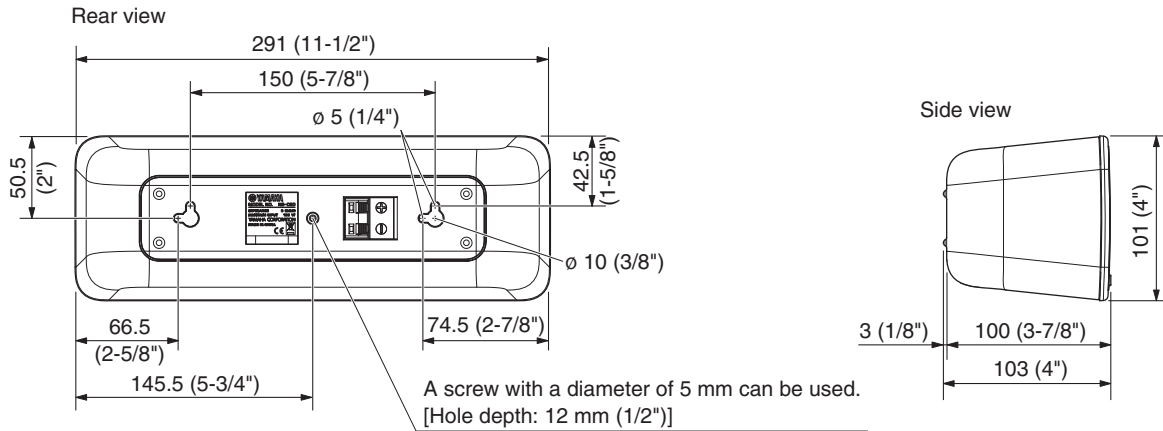

Unit: mm (inch)

▼ **NS-SWP20**

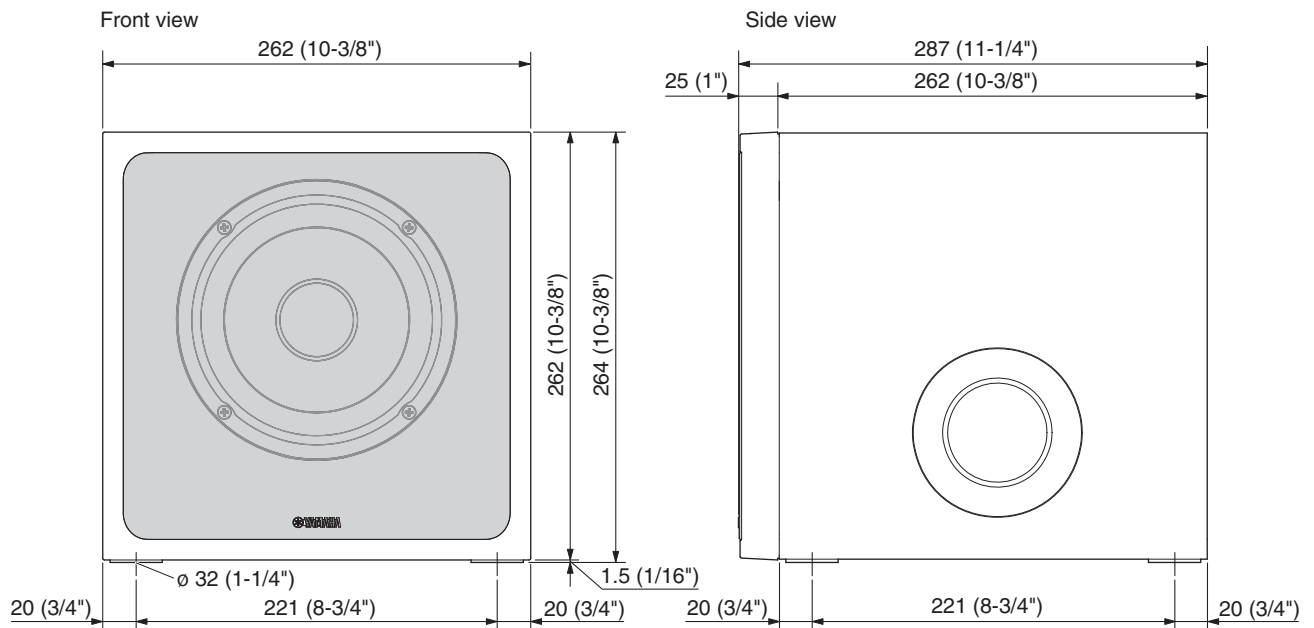

• SET MENU TABLE

MENU	SUB-MENU	VALUE		
General	System	Screen Saver	[On] / Off	
		Auto Power Off	Disc/USB/Net: [On] / Off Other Inputs: 1 hour / 2 hours / 4 hours / [8 hours] / Off	
Setting	System	Disc Auto Playback	[On] / Off	
		HDMI Control	On / [Off]	
		Load Default	Reset all settings of this Player to default setting except Security setting.	
		Upgrade	Upgrade the software manually from Disc, USB Storage or Network.	
		Easy Setup	Press ENTER to start Easy Setup.	
		Local Storage	Front USB / [Rear USB]	
		3D Playback Message	[On] / Off	
		Language	OSD	[English] / Français / Español / Deutsch / Italiano / Svenska / Nederlandse / Русский / 中文
			Menu	[English] / Français / 中文 / Español / Deutsch / Italiano / Nederlandse / Portuguese / Danish / Svenska / Finnish / Norwegian / Русский / Korean / Japanese / More
Audio				
Subtitle	English / Français / 中文 / Español / Deutsch / Italiano / Nederlandse / Portuguese / Danish / Svenska / Finnish / Norwegian / Русский / Korean / Japanese / More / [Off]			
Playback	Closed Caption	[On] / Off		
	Angle Mark	[On] / Off		
	PIP Mark	[On] / Off		
	Secondary Audio Mark	[On] / Off		
	Last Memory	[On] / Off		
	Netflix Information (U, C models)	Deactivate Yes / [No]		
Security	Change Password	Set the password for changing the Parental Control Level and Country Code. * Default password: 0000		
	Parental Control	[Off] / 1 to 8		
	Country Code	Set the Country Code. (Password is necessary)		
Network	Internet Connection	[Enable] / Disable		
	Information	Interface (Ethernet) / Address Type / IP Address / Subnet Mask / Default Gateway / DNS		
	Connection Test	Perform the network connection test.		
	IP Setting	[Auto] / Manual		
	BD-Live Connection	Permitted / [Partial Permitted] / Prohibited		
	DLNA	[Enable] / Disable		
	Proxy Setting	Enable / [Disable] / Proxy Host / Proxy Port		

MENU	SUB-MENU		VALUE	
Display Setting	TV	3D Output	[Auto] / Off	
		TV Screen	16:9 Full / [16:9 Normal] / 4:3 Pan Scan / 4:3 Letterbox	
		Video Out Select	Composite / [HDMI Auto] / HDMI 1080p / HDMI 1080i / HDMI 720p / HDMI 480p/576p / HDMI 480i/576i	
		TV System	[NTSC] / PAL / Multi (U, C models)	
			NTSC / [PAL] / Multi (T, G, F, L models)	
		Color Space	[YCbCr 4:4:4] / YCbCr 4:2:2 / Full RGB / RGB	
		HDMI Deep Color	30 bits / 36 bits / [Off]	
		HDMI 1080p 24Hz	[Auto] / Off	
	Lip Sync	[Auto] / Manual (2D / 3D) / Off		
	Video Process	Video Mode	[Standard] / Vivid / Cinema / Custom	
			Select "Custom": Brightness / Saturation / Hue / Contrast / Sharpness / CTI * Default settings: 0	
		Color Adjust	Brightness / Saturation / Hue for each color (Red/Green/Blue/Yellow/Cyan/Magenta) * Default settings: 0	
		Noise Reduction	[0] / 1 / 2 / 3	
		De-interlacing Mode	[Auto] / Film / Video	
Audio Setting	Audio	HDMI	Bitstream / PCM / [Off]	
	Output	DRC	[Off] / On / Auto	
		Speaker Setting	Configuration	Set the output of 5.1 ch surround depending on the connected speakers. Press Δ/∇ to select a speaker, press ENTER. Size: Large / [Small] Trim: -6 to +6 dB (in 0.5 dB step) * Default settings: 0 Delay: 0.5 to 10 m (in 0.5 m step) * Default settings: 3 m Disable: Yes / [No]
			2ch Downmix	[Stereo] / Lt/Rt
			Test Tone	check if the speaker setting is correct by outputting the test tone.
	Subwoofer Size	[Small] / Large		
	Post Process	Up Mix	[Off] / Dolby PLII / DTS NEO:6	
System Information			Software version and MAC address are displayed.	

INTERNAL VIEW

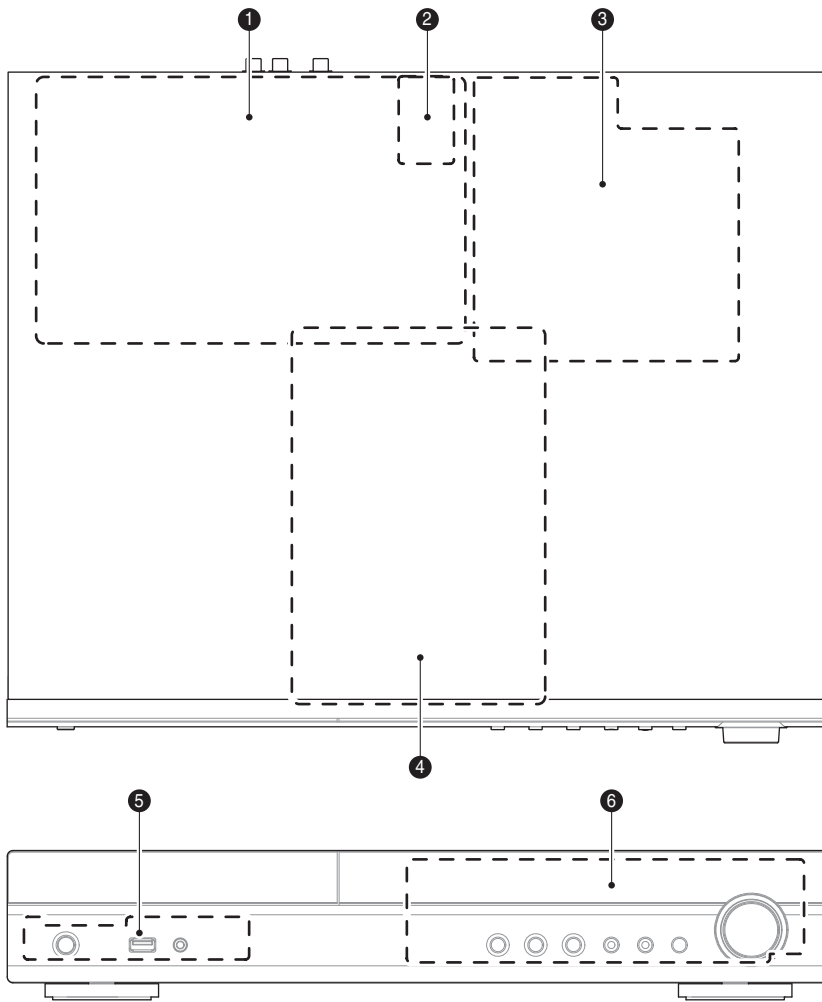

- ① MAIN P.C.B.
- ② FM TUNER
- ③ AMP P.C.B.
- ④ BD MECHANISM UNIT
- ⑤ USB P.C.B.
- ⑥ OPERATION P.C.B.

■ SERVICE PRECAUTIONS

When the MAIN P.C.B. is replaced, the serial number and new MAC address MUST be reported to Yamaha Corporation by e-mail. (Fig. 1)

E-mail: ycav-keycontrol@gmx.yamaha.com

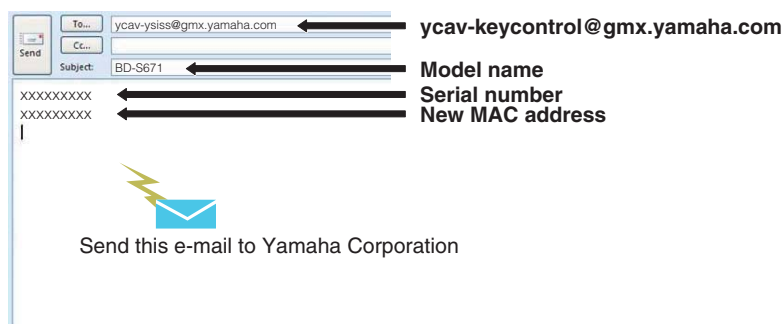

Fig. 1

● Confirmation of the Serial Number

The serial number “SER.No.xxxxxxx” can be found on the rear panel. (Fig. 2)

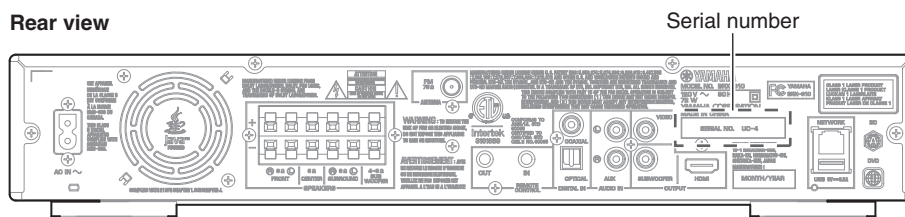

Fig. 2

● Confirmation of the New MAC address

Connection

Connect a TV monitor to this unit as shown below. (Fig. 3)

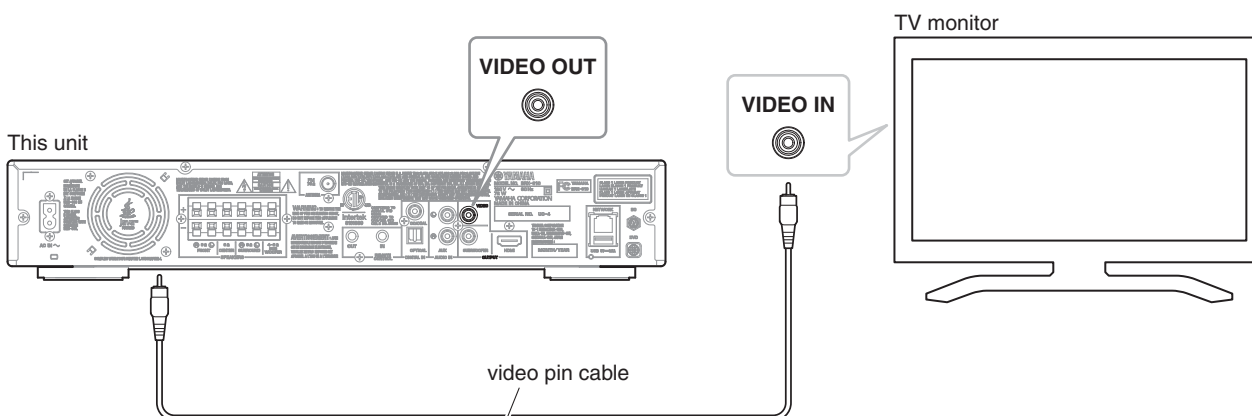

Fig. 3

Operation Procedure

Using the remote control, perform the following procedure while watching the TV monitor screen.



1. With this unit in the standby mode, press the “” (On/Standby) key to turn on the power.
The initial screen is displayed.
2. Press the “SETUP” key.
The SETUP menu is displayed. (Fig. 4)



Fig. 4

3. Press the “”/“” key to select the System Information.
The new MAC address is displayed. (Fig. 5)

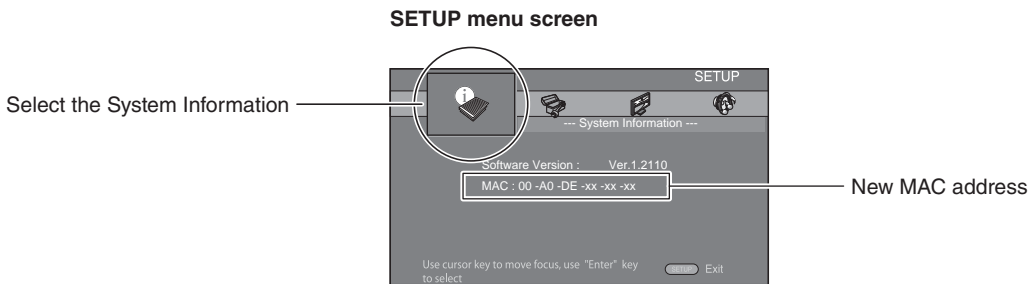

Fig. 5

■ DISASSEMBLY PROCEDURES

(Remove parts in the order as numbered.)
Disconnect the power cable from the AC outlet.

1. Removal of Top Cover

- Remove 4 screws (①) and 4 screws (②). (Fig. 1)
- Remove the top cover. (Fig. 1)

2. Removal of BD Mechanism Unit

- Remove 4 screws (③). (Fig. 1)
- Lift the BD mechanism unit. (Fig. 1)
- Remove HA4 and JP18. (Fig. 1)
- Remove HA2 and ground the terminal side of the flexible flat cable with a clip or the like.
- Remove the BD mechanism unit. (Fig. 1)

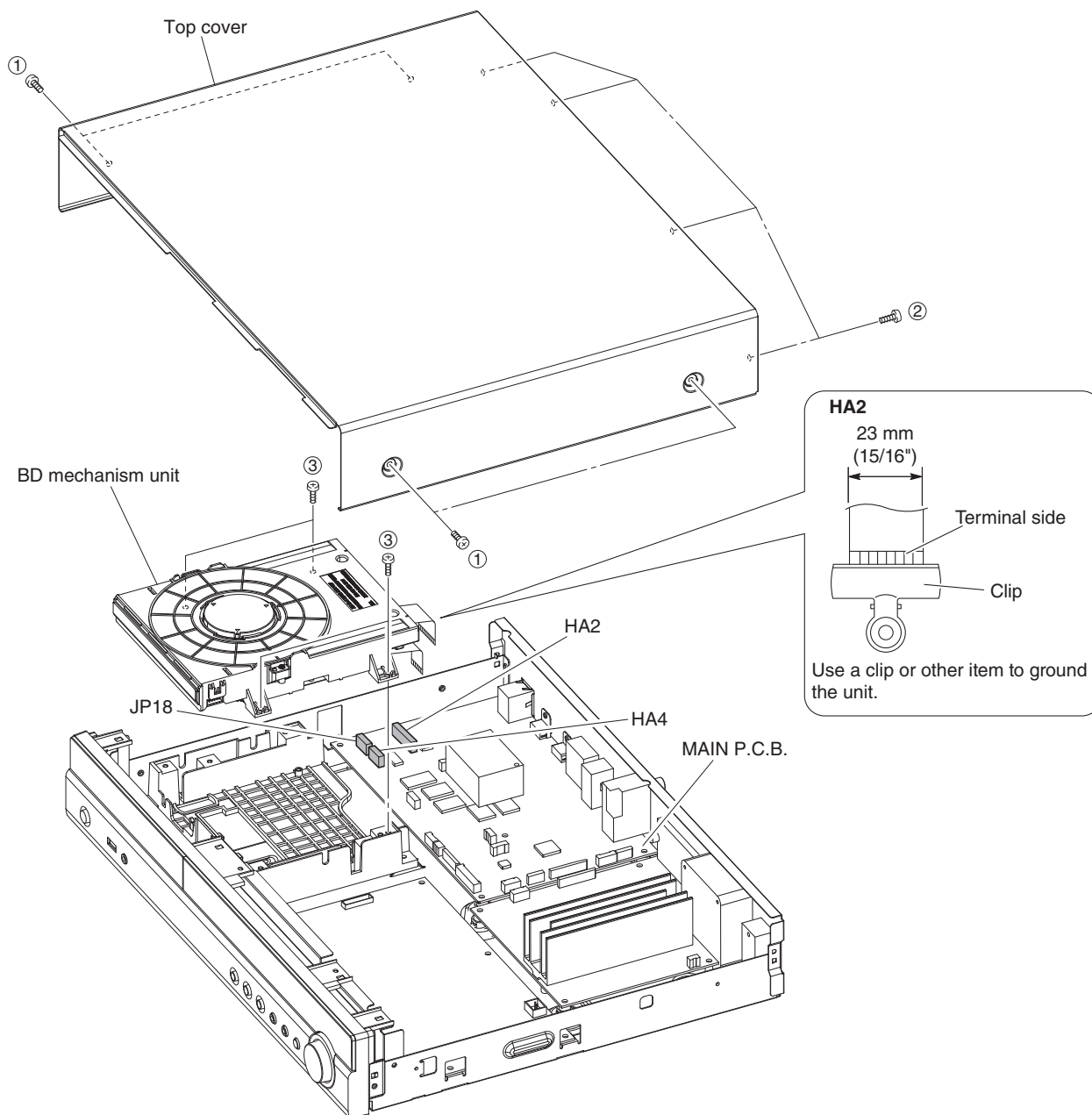

Fig. 1

- **How to manually eject the disc tray**

- Using an Allen hex socket screwdriver (size: 1.3 mm or .050"), move the slider at the bottom side in the direction of the arrow as shown below until the disc tray comes out. (Fig.2)
- Gently pull the disc tray out. (Fig. 2)

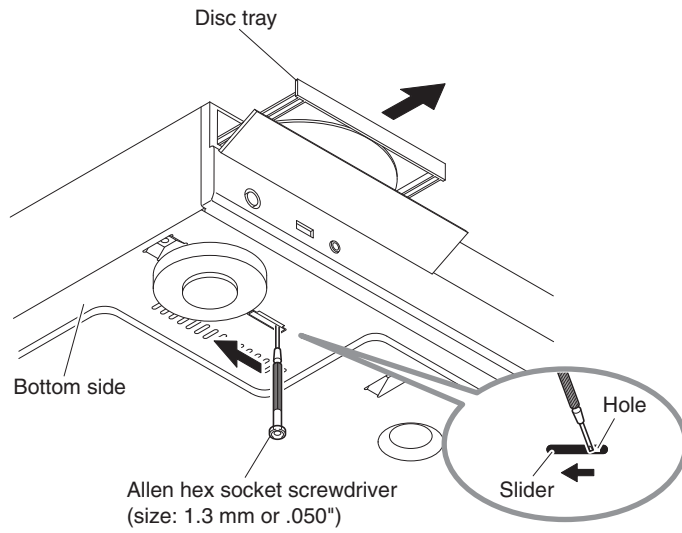

Fig. 2

2-1. Removal of Loading Belt

- Remove 2 screws (④). (Fig. 3)
- Release 2 hooks and then remove the top case. (Fig. 3)
- Eject the disc tray and then remove the loading belt. (Fig. 3)

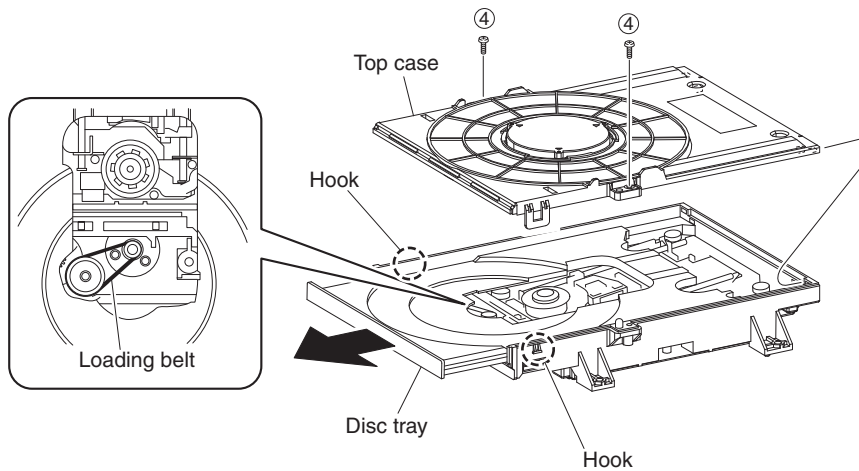

Fig. 3

3. Remove the MAIN P.C.B.

- a. Remove 3 screws (⑤), 2 screws (⑥), screw (⑦) and 2 screws (⑧). (Fig. 4)
- b. Remove JP1, JP6, JP8, JP9, JP13, JP14 and JP15. (Fig. 4)
- c. Remove the MAIN P.C.B. (Fig. 4)

4. Removal of AMP P.C.B.

- a. Remove 6 screws (⑨), 2 screws (⑩) and 2 screws (⑪). (Fig. 4)
- b. Remove JP701-704. (Fig. 4)
- c. Remove the AMP P.C.B. (Fig. 4)

5. Removal of Power Supply Unit

- a. Remove 4 screws (⑫) and 2 screws (⑬). (Fig. 4)
- b. Remove CON1. (Fig. 4)
- c. Remove the power supply unit. (Fig. 4)

6. Removal of Front Panel Unit

- a. Remove 2 screws (⑭) and 5 screws (⑮). (Fig. 4)
- b. Release 2 hooks and then remove the front panel unit. (Fig. 4)

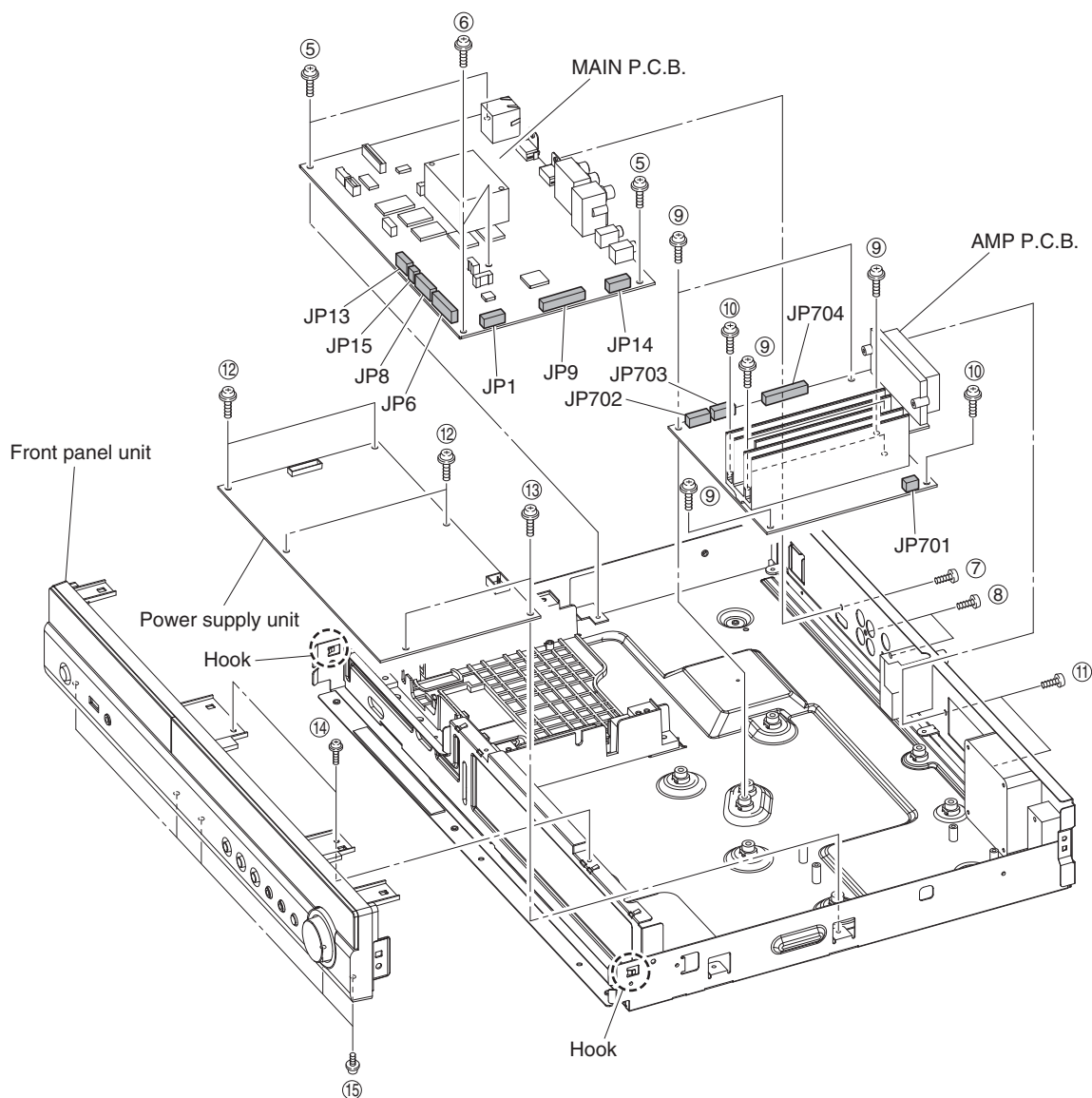

Fig. 4

■ REWRITING OPU PARAMETER

* OPU stands for Optical Pick-up Unit.

When the following parts are replaced, the OPU parameter of the BD mechanism unit, which is written to the FLASH ROM on MAIN P.C.B., must be rewritten to have proper operation.

BD mechanism unit
MAIN P.C.B.

● Required Tools

Items supplied from Yamaha Corporation

- OPU parameter writing program: Rpower.exe
- USB-UART conversion adaptor kit (Part No. WW867800)
USB-UART conversion adaptor x 1, USB cable (type A to type A) x 1, 4P flexible flat cable x 1 (Not for service)
- Test disc set (Part No. WW867900)
CD-ROM x 1, DVD-ROM DL x 1, BD-ROM SL x 1, BD-R DL x 1, BD-ROM DL x 1 (Not for service)

Items not supplied from Yamaha Corporation

- PC
- 2D barcode reader (which supports Data Matrix symbology)
- TV monitor

● Preparation and precaution

- Download the Rpower 8550 5.12.61 (KEM470) folder from the specified download source to the PC.
- While writing OPU parameter, keep the other application software on the PC closed. It is also recommended to keep the software on the task tray closed as well.

● Outline of operation procedure

<When replacing BD mechanism unit>

1. Read the OPU parameter of a replacement BD mechanism unit in advance, and save it to the PC. (See "Reading and saving OPU parameter")
2. Install the replacement BD mechanism unit after removing the old one.
3. Write the OPU parameter saved on the PC to the FLASH ROM on MAIN P.C.B., and check disc playback capability consecutively. (See "Writing OPU Parameter and Disc Playback Capability Check")

<When replacing MAIN P.C.B.>

1. Replace the MAIN P.C.B.
2. Remove the BD mechanism unit once.
3. Read the OPU parameter of the removed BD mechanism unit, and save it to the PC. (See "Reading and saving OPU parameter")
4. Reinstall the removed BD mechanism unit.
5. Write the OPU parameter saved on the PC to the FLASH ROM on MAIN P.C.B., and check disc playback capability consecutively. (See "Writing OPU Parameter and Disc Playback Capability Check")

● Details of Operation Procedure

Reading and saving OPU parameter

Read the 2D barcode (= OPU parameter) indicated on the bottom surface of the BD mechanism unit with a 2D barcode reader and save it to the PC after decoding it to the text data. (Fig. 1)

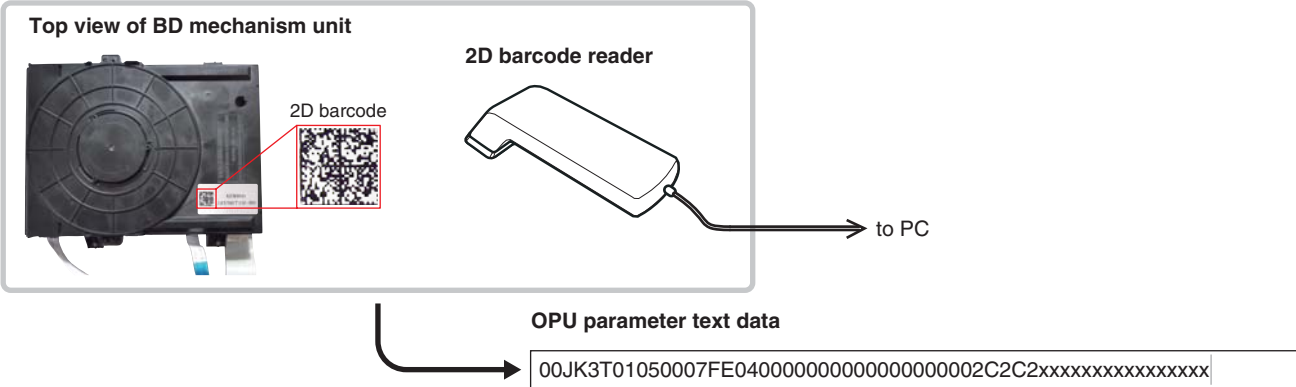

Fig. 1

Note: If you don't have 2D barcode reader, take a picture of 2D barcode with a digital camera, and send its image data to the following e-mail address.

E-mail: ycav-ysiss@gmx.yamaha.com

Yamaha Corporation will reply providing the OPU parameter text data. (Fig. 2)

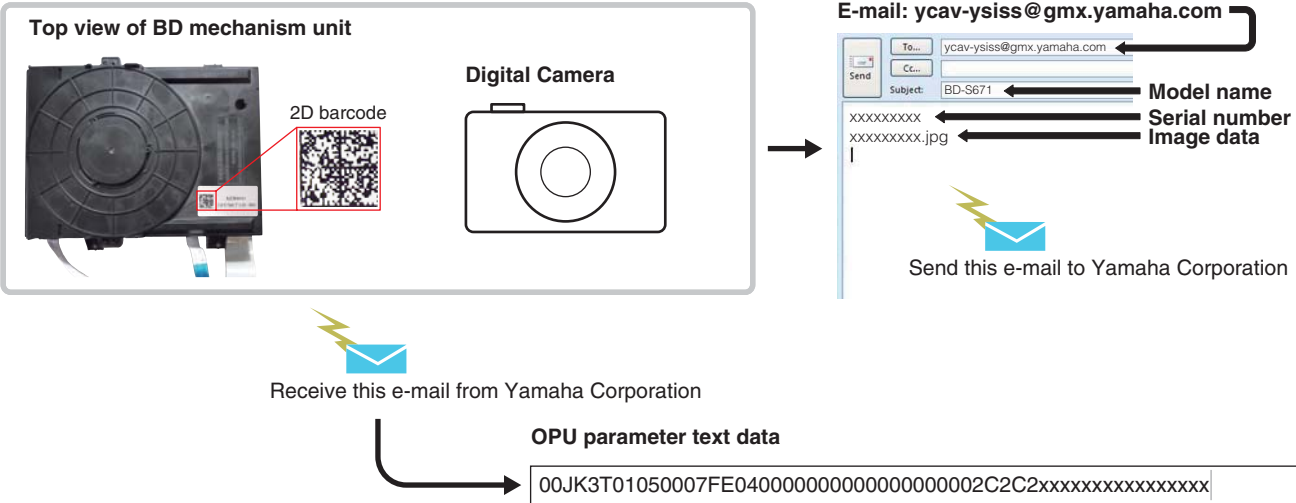

Fig. 2

Writing OPU Parameter and Disc Playback Capability Check

<Connection>

1. Disconnect the power cable from the AC outlet and remove the top cover. (See “DISASSEMBLY PROCEDURES”.)
2. Connect the USB port of the PC to the writing port (JP10 on MAIN P.C.B.) of this unit as shown below. (Fig. 3)

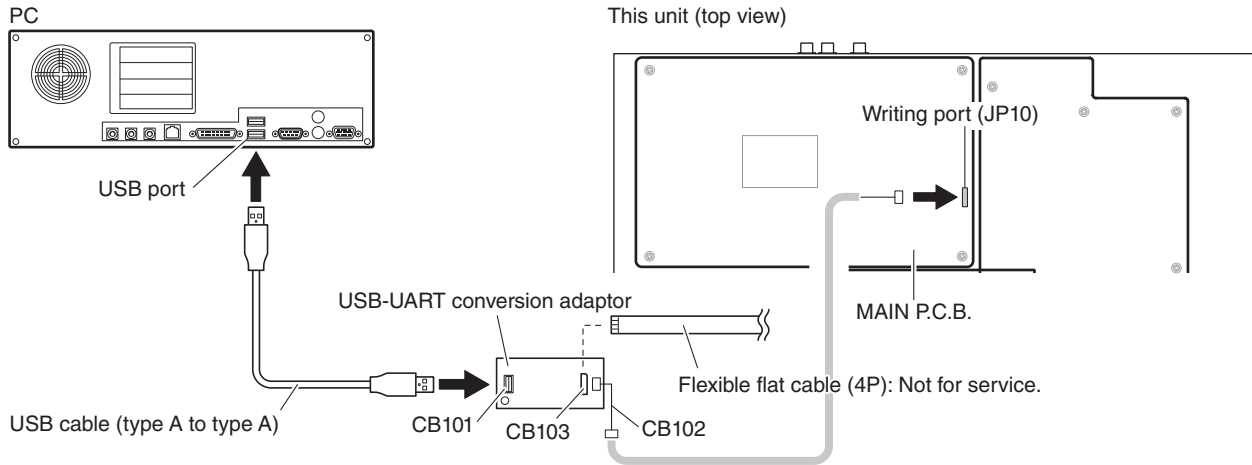

Fig. 3

3. Connect the VIDEO IN jack of the TV monitor to the VIDEO OUT jack of this unit as shown below. (Fig. 4)

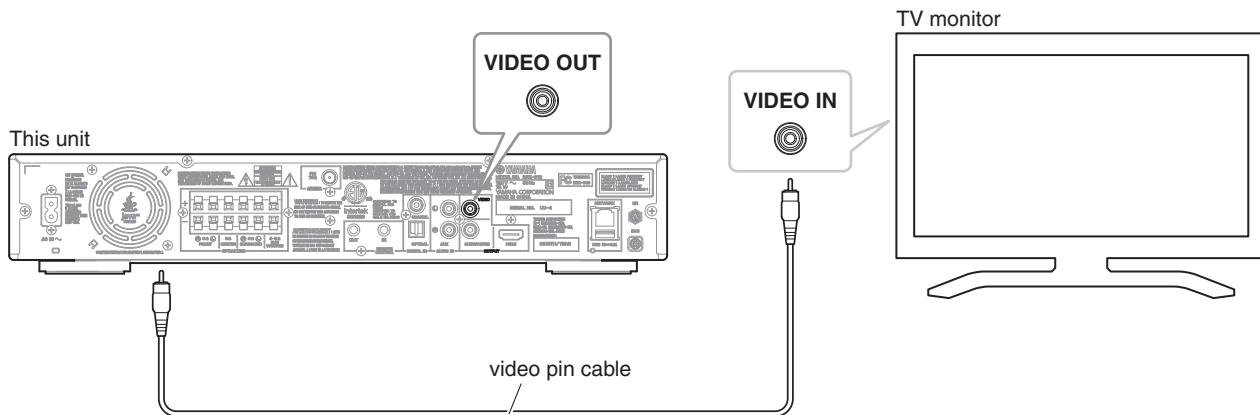

Fig. 4

<Operation>

The operation consists of 2 parts as follows.

Procedure 1 to 8: Writing OPU Parameter

Procedure 9 to 13: Disc Playback Capability Check

1. Press the “” (On/standby) key to turn on the power.

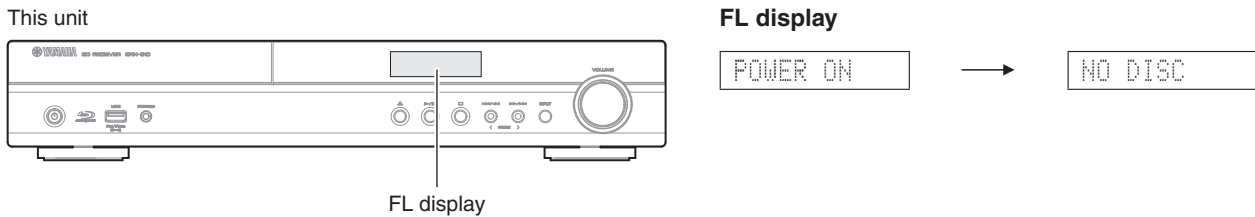

Fig. 5

2. Start up Rpower.exe.
The screen appears as shown below. (Fig. 6)
3. Select the port and baud rate. (Fig. 6)
 - COM port: Select the USB port of PC connected to the USB–UART conversion adaptor.
 - Baud rate: Select “115200”.

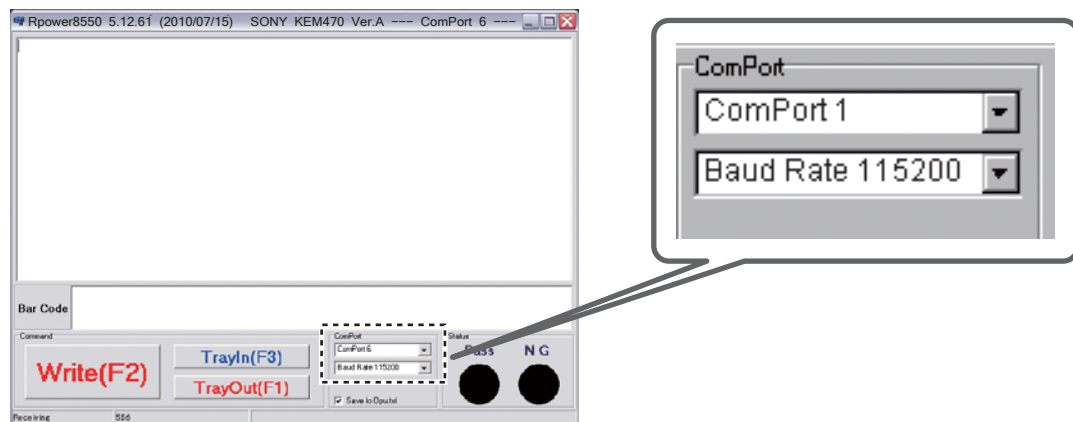

Fig. 6

4. Follow the steps below to check that communication between the PC and this unit is established.
 - Click [TrayOut F1]. The disc tray opens. (Fig. 7)
 - Click [TrayIn F3]. The disc tray closes. (Fig. 7)
- * If the disc tray does not operate, recheck the connection especially the COM port of the PC and perform operation from the beginning again.

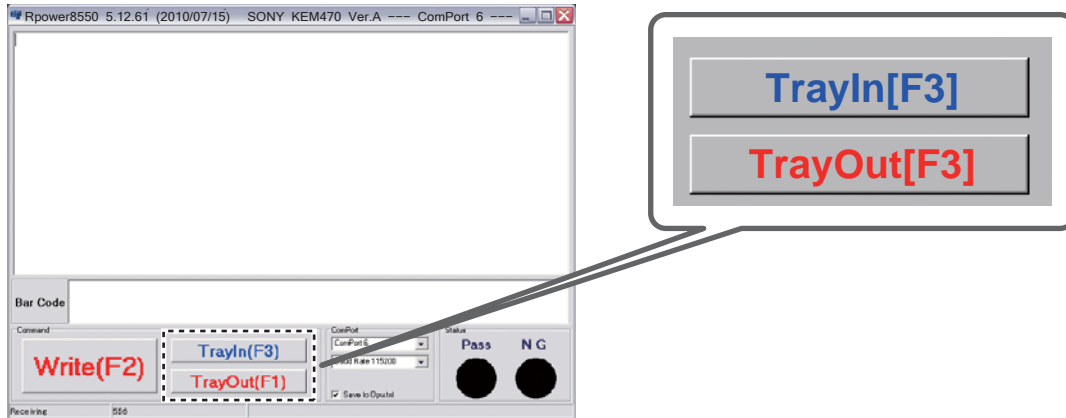

Fig. 7

5. Copy the OPU parameter text data from the PC to [Bar Code]. (Fig. 8)

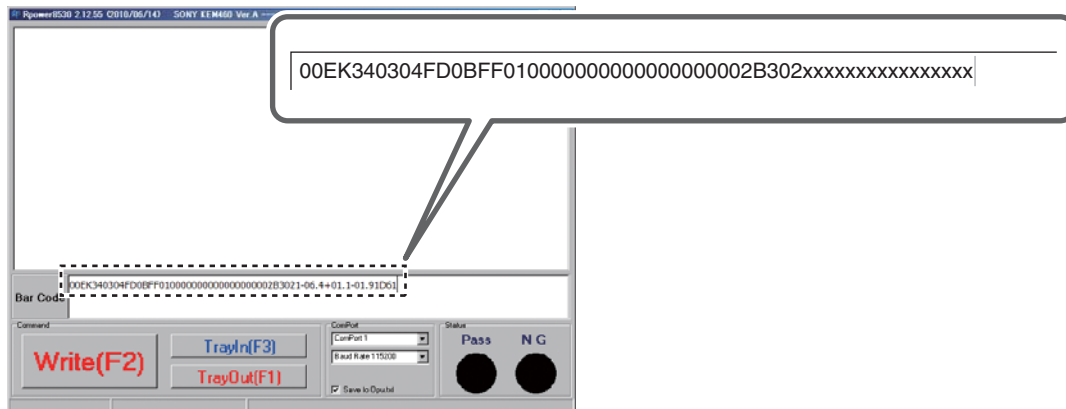
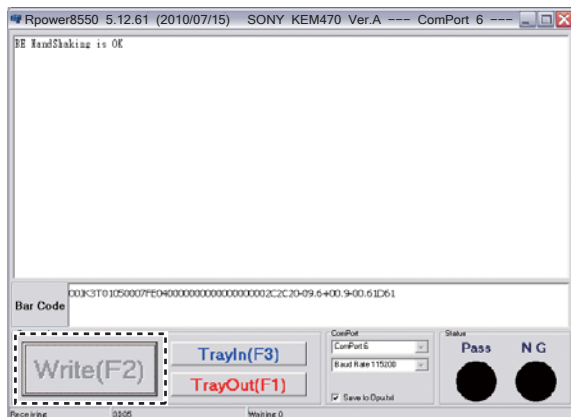

Fig. 8

- Click [Write (F2)] to start writing the OPU parameter. (Fig. 9)
When writing of the OPU parameter is completed, the "Pass" indicator lights green. (Fig. 9)

Writing being executed



Writing completed

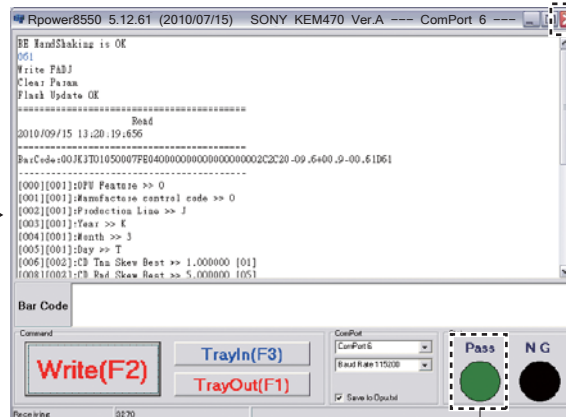

Fig. 9

- * When the "NG" indicator lights red, perform "Writing OPU Parameter and Disc Playback Capability Check" from the beginning. (Fig. 10)



Fig. 10

- Click [X] to end Rpower.exe. (Fig. 11)

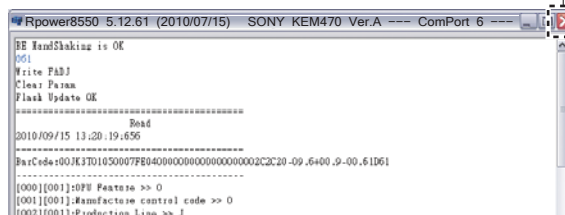

Fig. 11

- Press the "⏻" (On/standby) key to turn off the power.

9. Press the "⏻" (On/standby) key to turn on the power.

The FA mode is activated and the screen appears on the TV monitor as shown below. (Fig. 12)

TV monitor screen

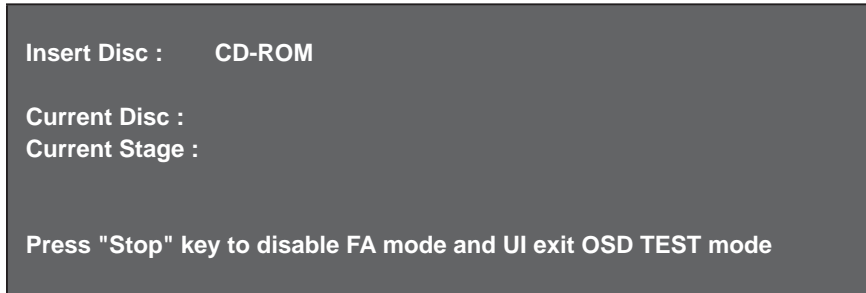
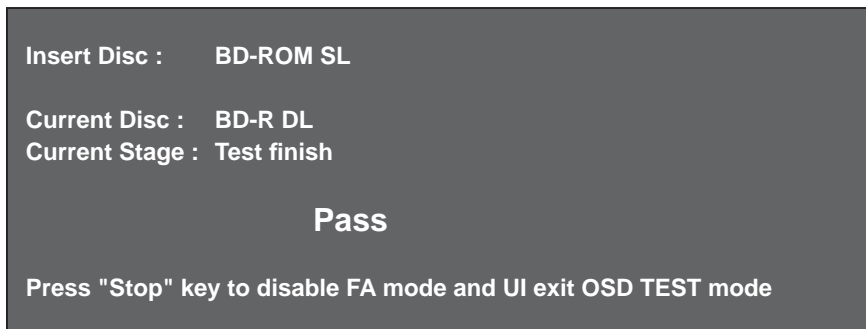

Fig. 12

10. Load the test disc on the disc tray according to the direction displayed on the TV monitor screen, and push the disc tray to close it. Then playback starts automatically, and then the disc tray opens automatically after playback ends. (Fig. 13)
- Repeat above procedure 4 times to complete the playback capability test by using 4 kinds of test discs.

TV monitor screen



* Required time for play

- BD-ROM SL : About 30 seconds
- BD-R DL : About 60 seconds
- DVD-ROM DL : About 60 seconds
- CD-ROM : About 30 seconds

(BD ROM DL: Not for service)

Fig. 13

11. "Pass" is displayed when the playback capability test is completed successfully.
- If "Fail" is displayed, check that the test discs are not dirty and scratched, then perform test from procedure 8 again.
12. Press the "■" (Stop) key to cancel the FA mode.
- TV monitor screen is turned off and "OK C3" is displayed on the FL display of this unit.
13. Press the "⏻" (On/Standby) key to turn off the power.

Note: Be sure to cancel the FA mode by pressing the "■" (Stop) key before turning off the power. Otherwise the FA mode is activated next time the power is turned on.

■ SELF-DIAGNOSTIC FUNCTION

This unit has self-diagnostic functions that are intended for inspection and location of faulty point.

● Starting Self-Diagnostic Function

While pressing the “◀◀/▶▶” and “▶▶/▶▶” keys, connect the power cable to the AC outlet and keep pressing those 2 keys. When the “NO PROTECTION” is displayed, release those 2 keys. (Fig. 1)

The self-diagnostic function is activated. (Fig. 1)

CAUTION!

Pressing the “◀◀/▶▶” and “▶▶/▶▶” keys for longer than 6 seconds will activate the self-diagnostic function with protection functions disabled.

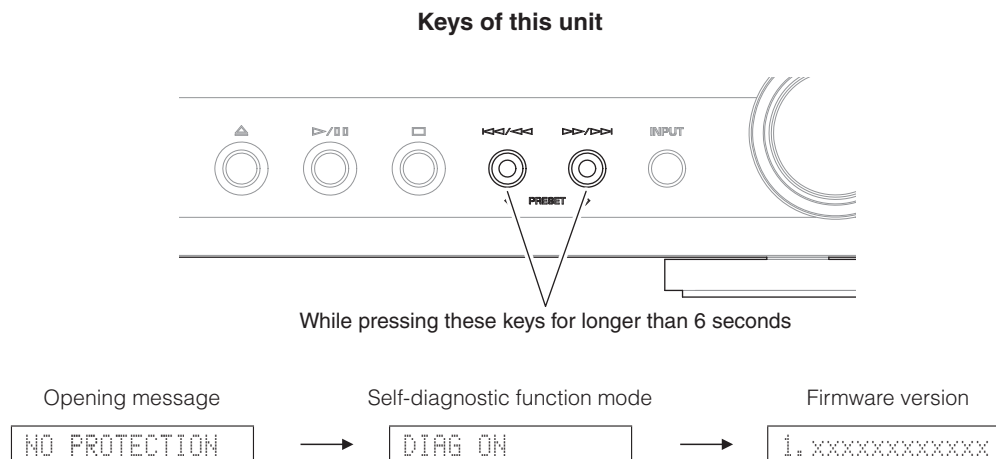

Fig. 1

● Starting Self-Diagnostic Function in the protection cancel mode

If the protection function works and causes hindrance to troubleshooting, cancel the protection function by the procedure below, and it will be possible to enter the self-diagnostic function.

While pressing the “◀◀/▶▶” and “▶▶/▶▶” keys, connect the power cable to the AC outlet and keep pressing those 2 keys for 6 seconds or longer. (Fig. 2)

The self-diagnostic function is activated with the protection functions disabled.

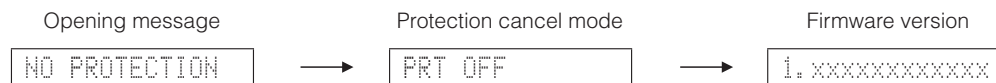

Fig. 2

CAUTION!

Using this product with the protection function disabled may cause further damage to this unit. Use special care for this point when using this mode.

● Canceling Self-Diagnostic Function

Disconnect the power cable from the AC outlet. The self-diagnostic function is cancelled.

● Details of Self-Diagnostic Function

1. FL Display Check

- 1) Press the "▶" (Play) key on the remote control. (Fig. 3)
Check that all segments of the FL display turn on. (Fig. 3)
- 2) Press the "■" (Stop) key on the remote control. (Fig. 3)
Check that all segments of the FL display turn off. (Fig. 3)

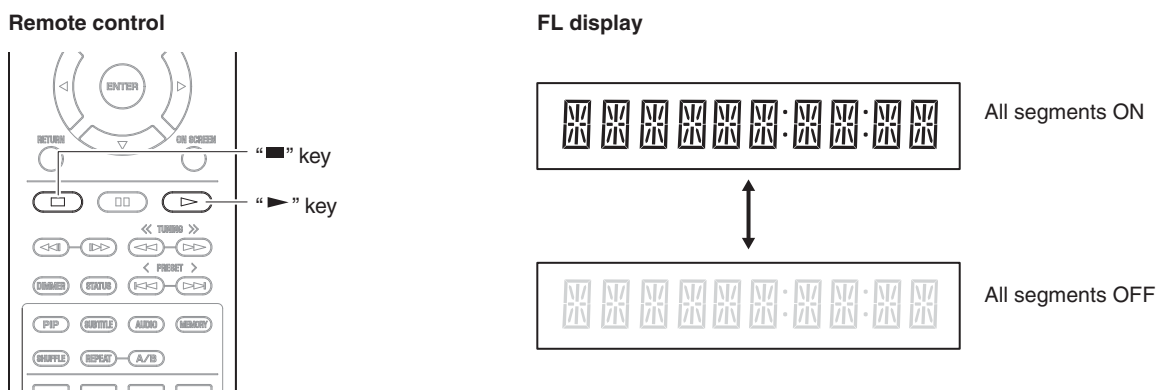

Fig. 3

2. Front Panel Key Check

When any key on the front panel is pressed, the corresponding key name is displayed. (Fig. 4)
Press each key one by one and check that the corresponding key name is displayed properly. (Fig. 3)

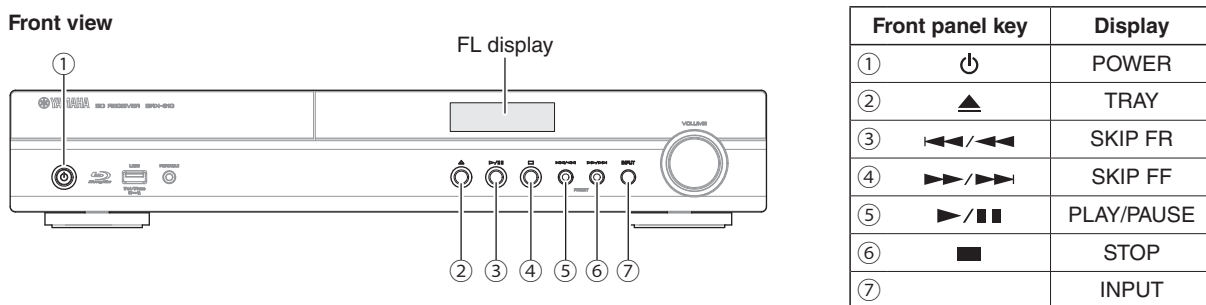

Fig. 4

3. Protection History Check

This menu is used to display the history of protection function.

Press the "DISPLAY" key on the remote control and the history of protection function is displayed. (Fig. 5)

* Numeric values in the figure are given as reference only.

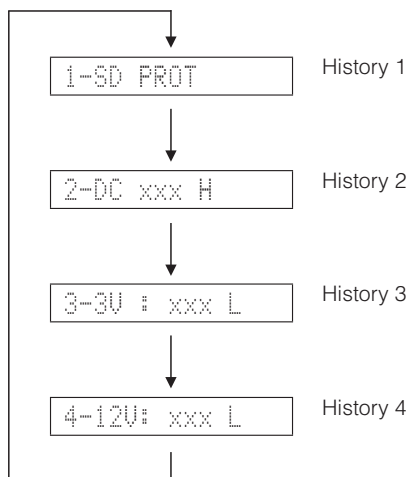

The history of protection function is as shown below.

SD PROT: Digital amplifier shut down detection

DC xxx H: DC voltage of speaker output protection detection

1V xxx L: 1.15V/1.5V power supply voltage protection detection

3V xxx L: 3V/5V power supply voltage protection detection

12V xxx L: 12V/-VP power supply voltage protection detection

20V xxx L: 20V power supply voltage protection detection

H: Displayed when the voltage is HIGHER than upper limit

L: Displayed when the voltage is LOWER than lower limit

xxx: A/D conversion value of voltage at the moment when the protection function worked

NO PRT: No protection

Fig. 5

1 ■ BLOCK DIAGRAM

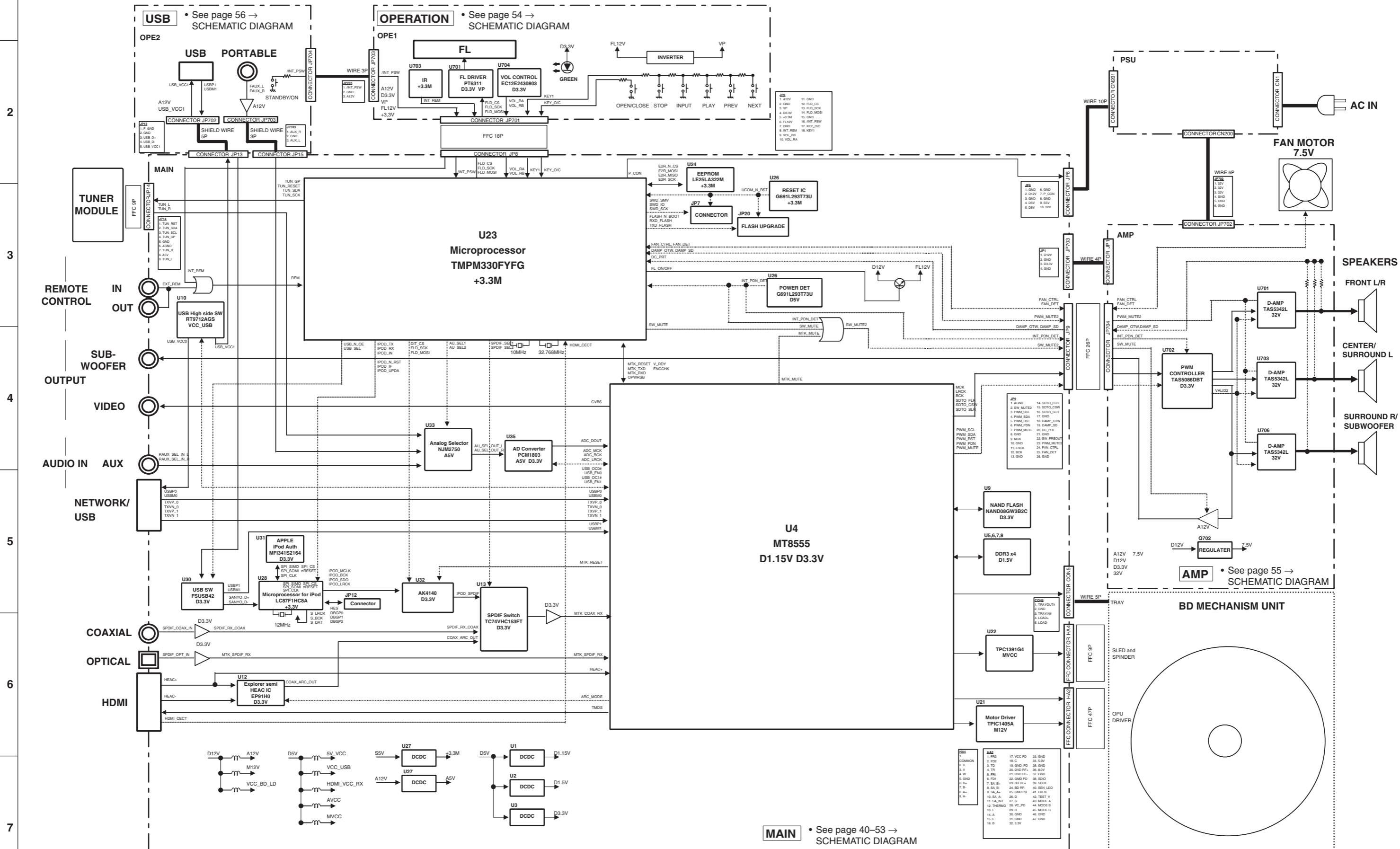

7

MAIN • See page 40-53 → SCHEMATIC DIAGRAM

■ WIRING DIAGRAM

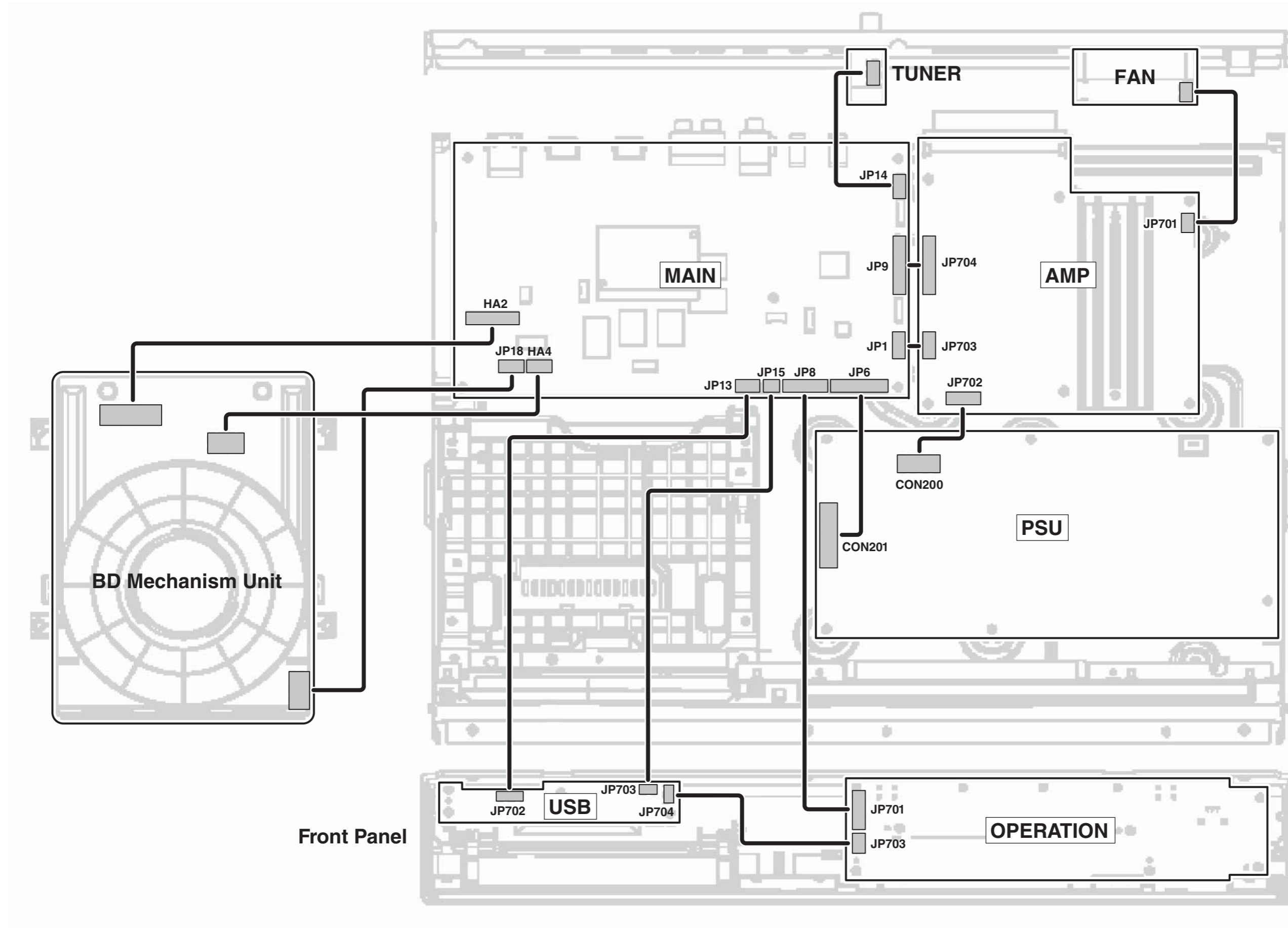

1 ■ PRINTED CIRCUIT BOARDS
FOR INFORMATION ONLY (COMPONENT PARTS NOT AVAILABLE)

MAIN (Side A)

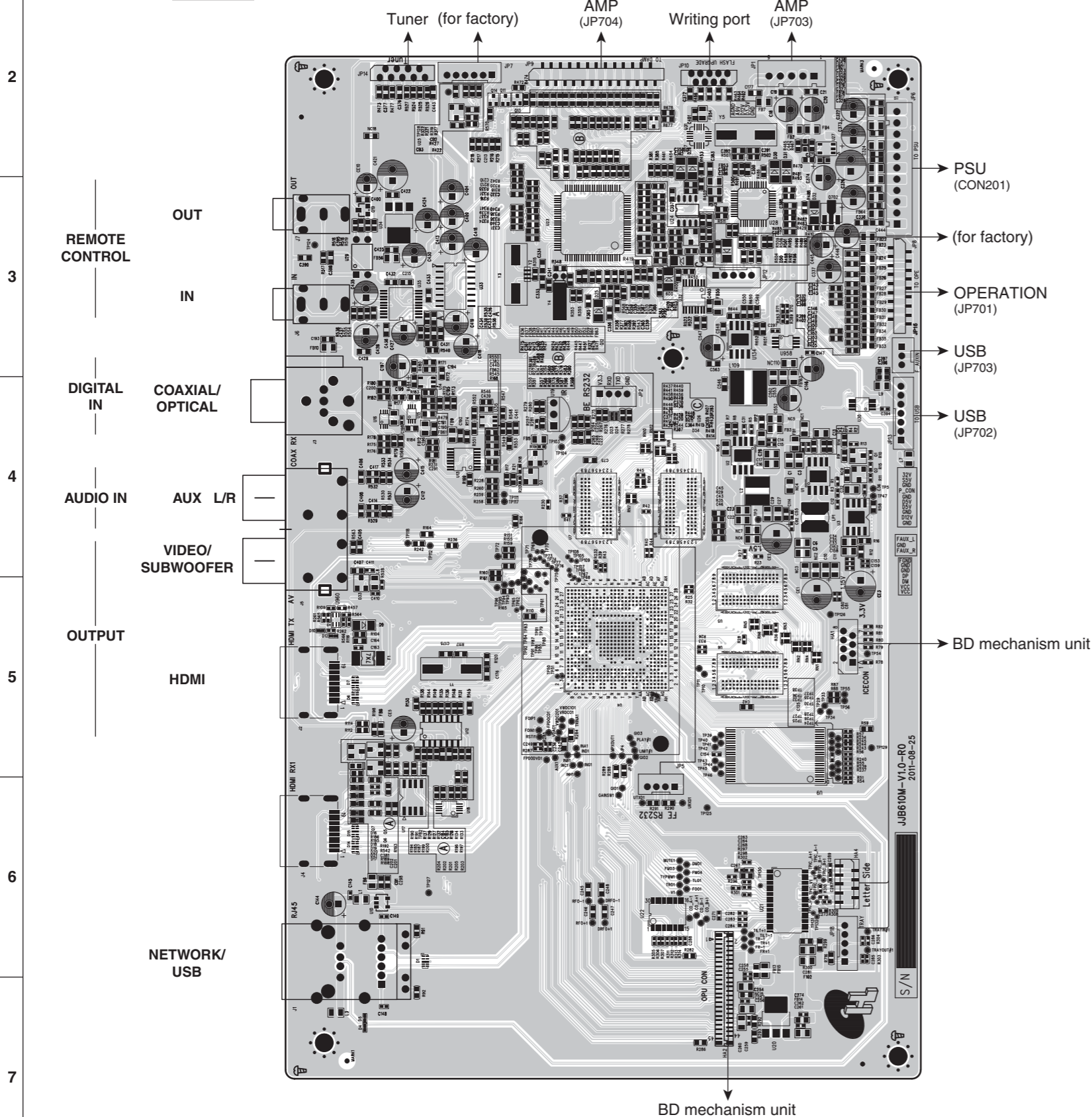

MAIN (Side B)



OPERATION (Side A)

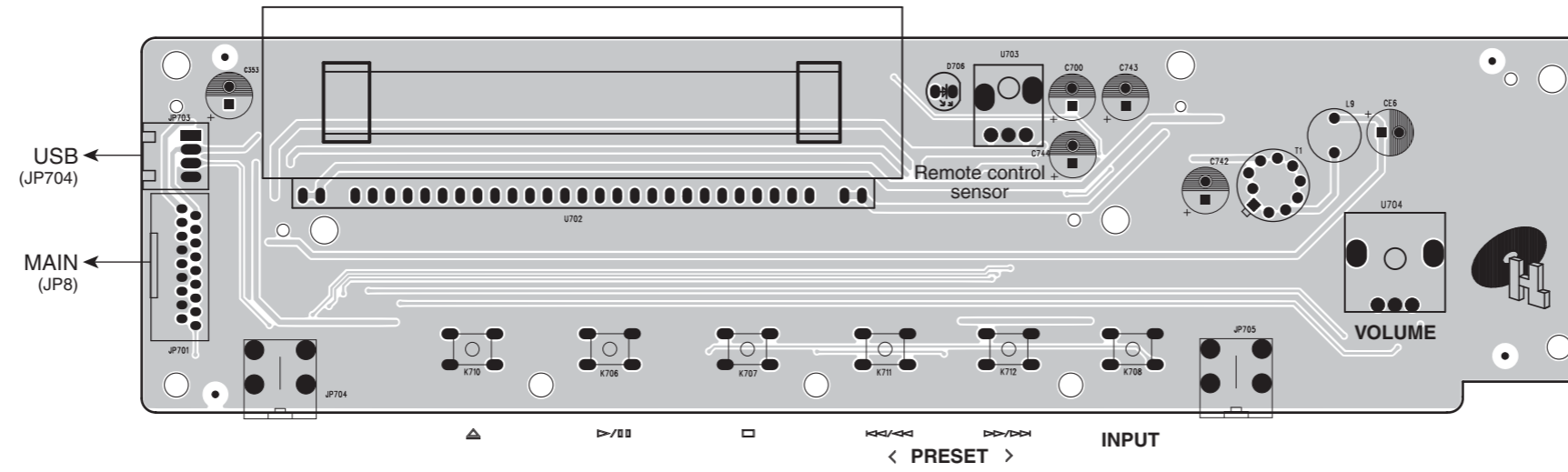

OPERATION (Side B)

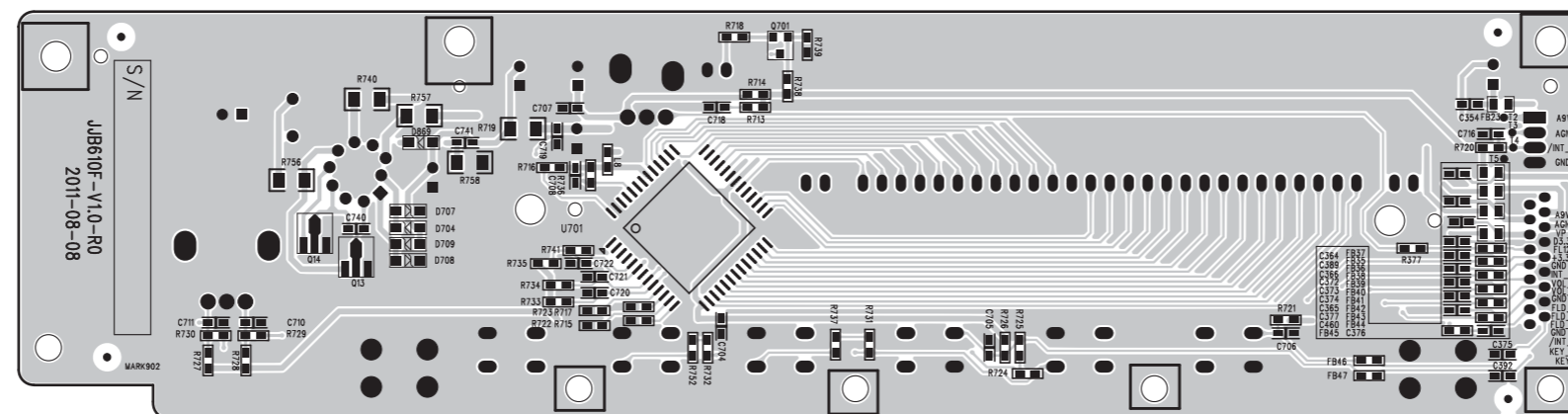

1
2
3
4
5
6
7

AMP (Side A)

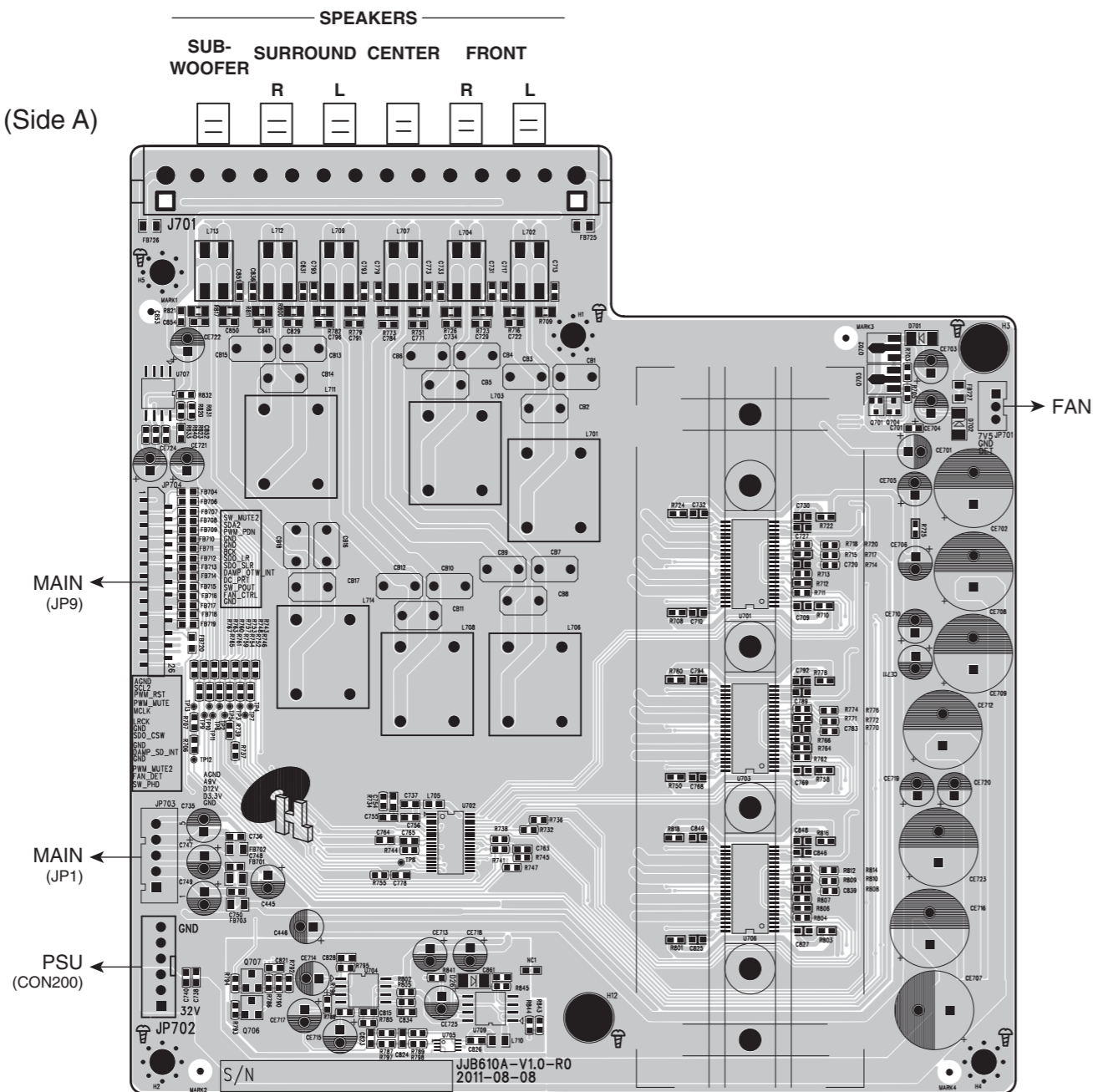

AMP (Side B)

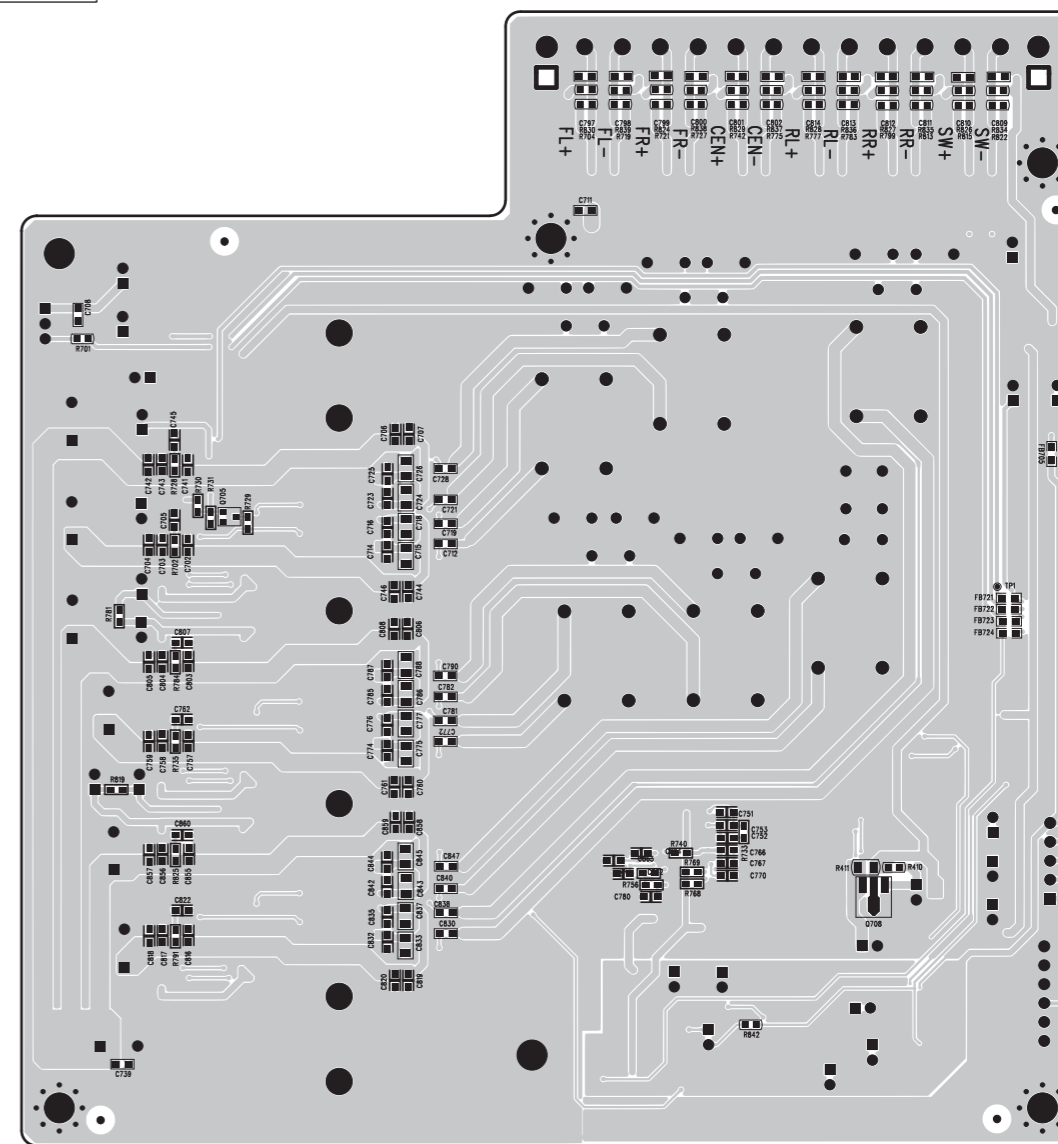

USB (Side A)

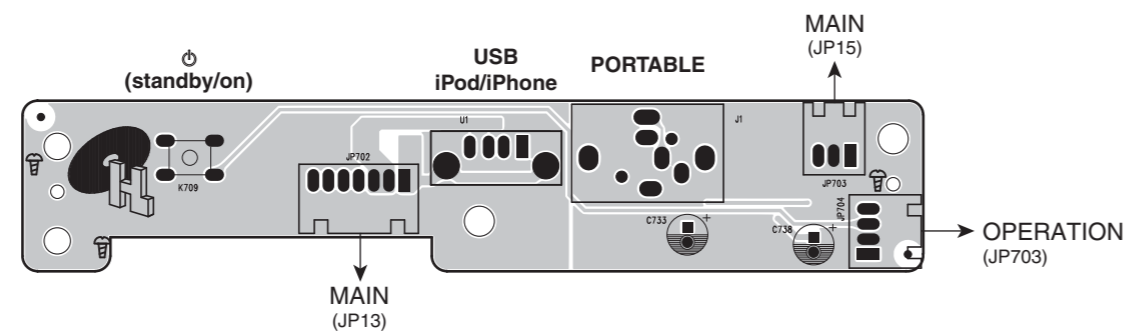

USB (Side B)

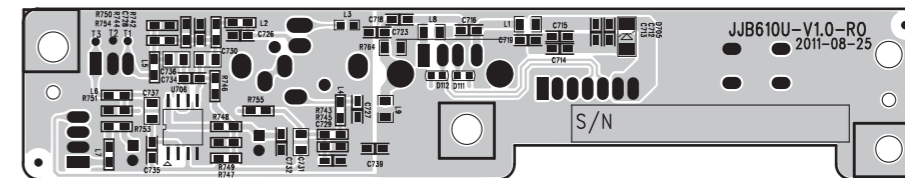

SCHEMATIC DIAGRAMS

FOR INFORMATION ONLY (COMPONENT PARTS NOT AVAILABLE)

MAIN 1/14

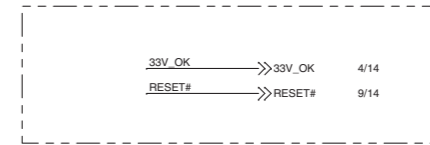
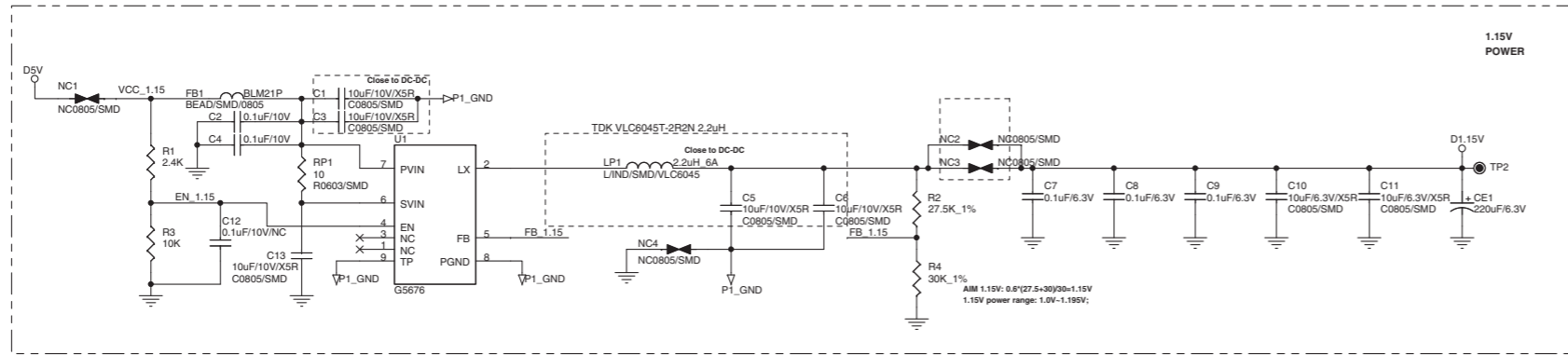

Page 55 B3 to AMP_JP703

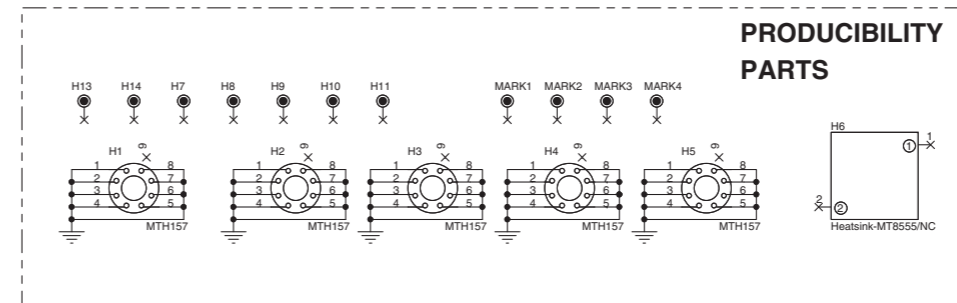
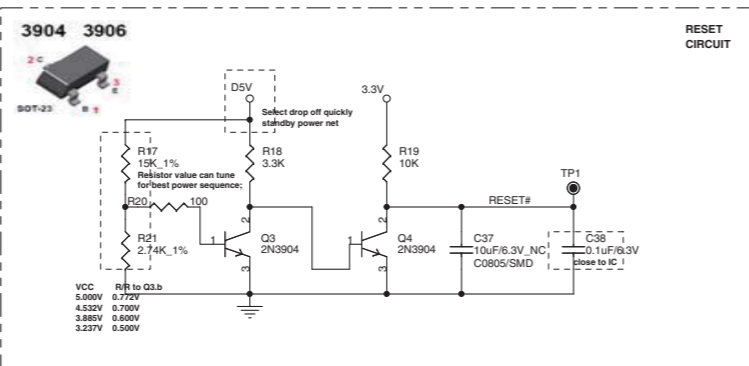
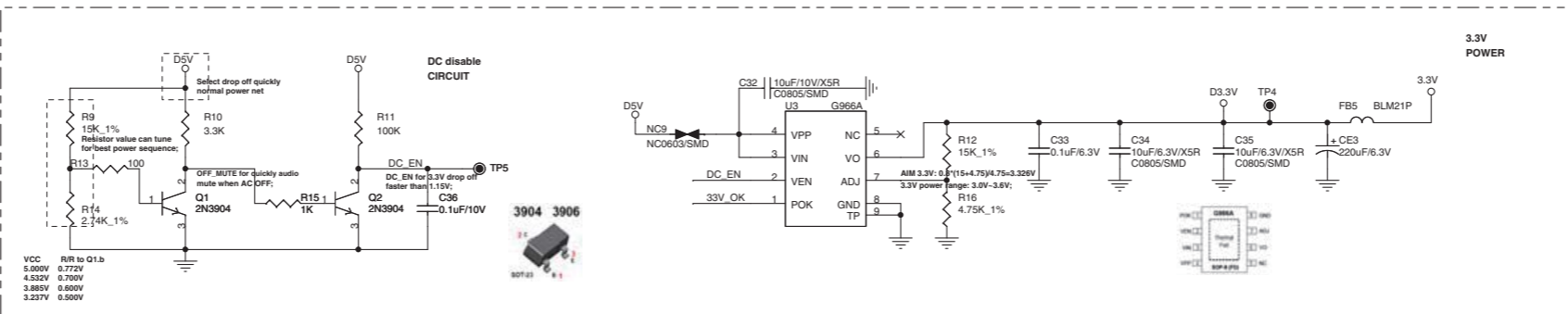
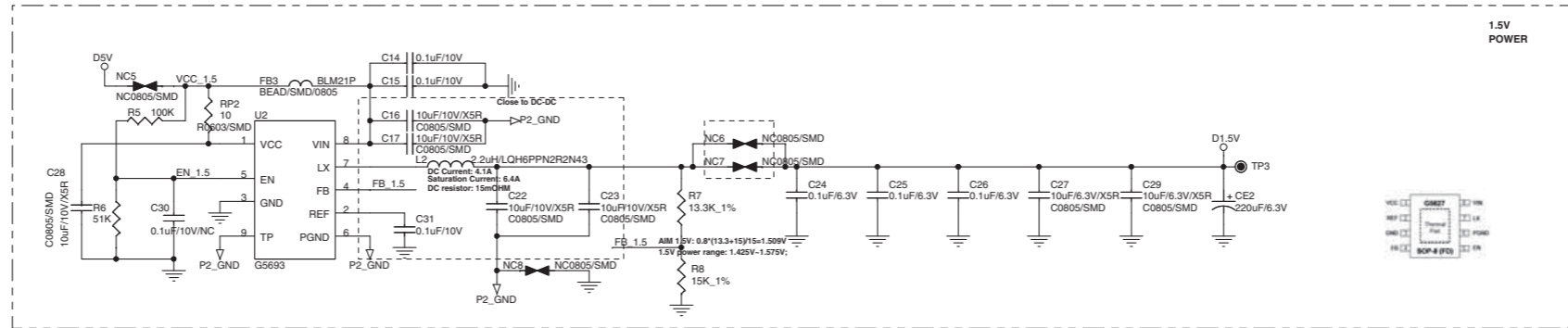
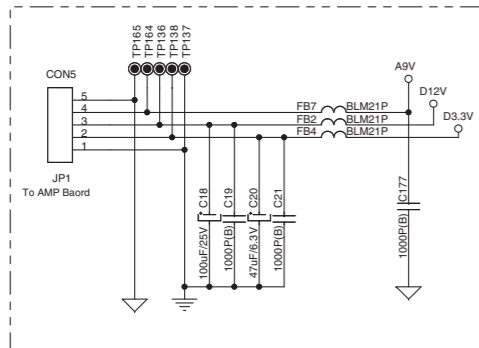

- ★ Components having special characteristics are marked Δ and must be replaced with parts having specifications equal to those originally installed.
- ★ Schematic diagram is subject to change without notice.

MAIN 2/14

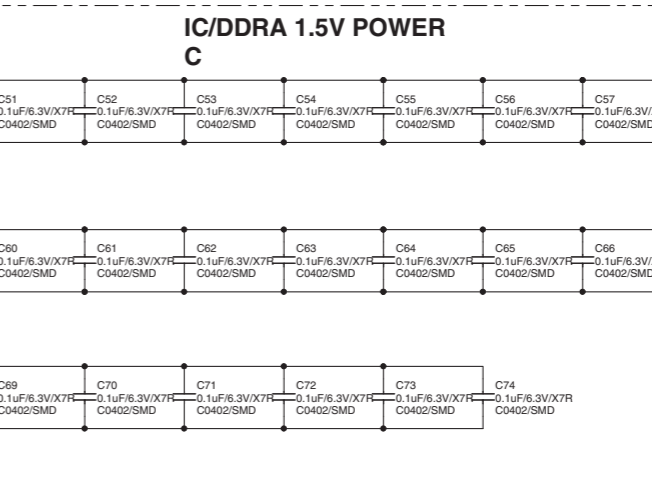
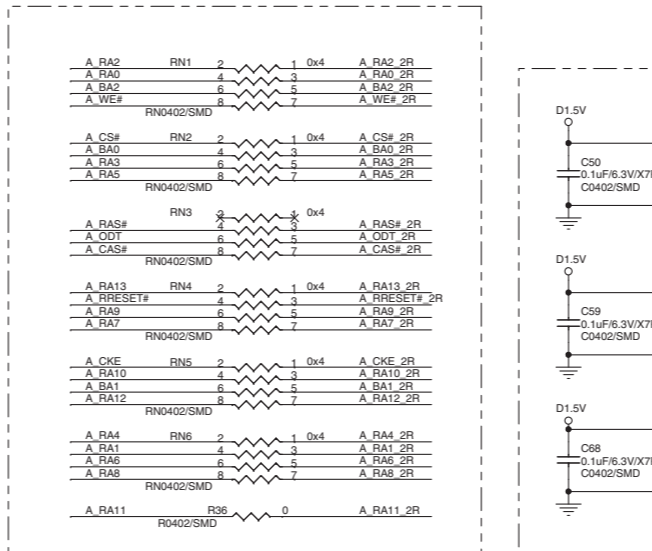
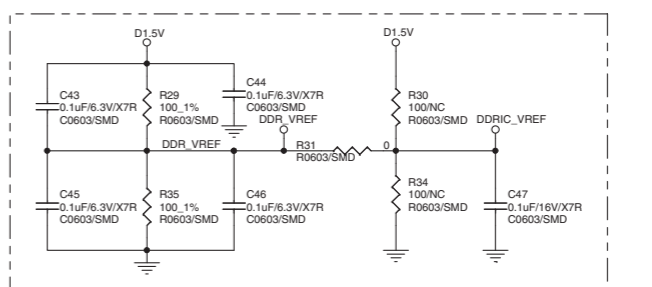
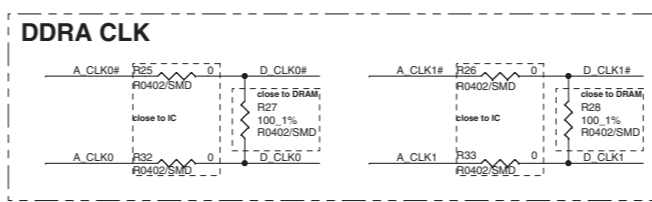
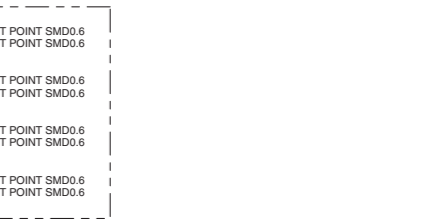
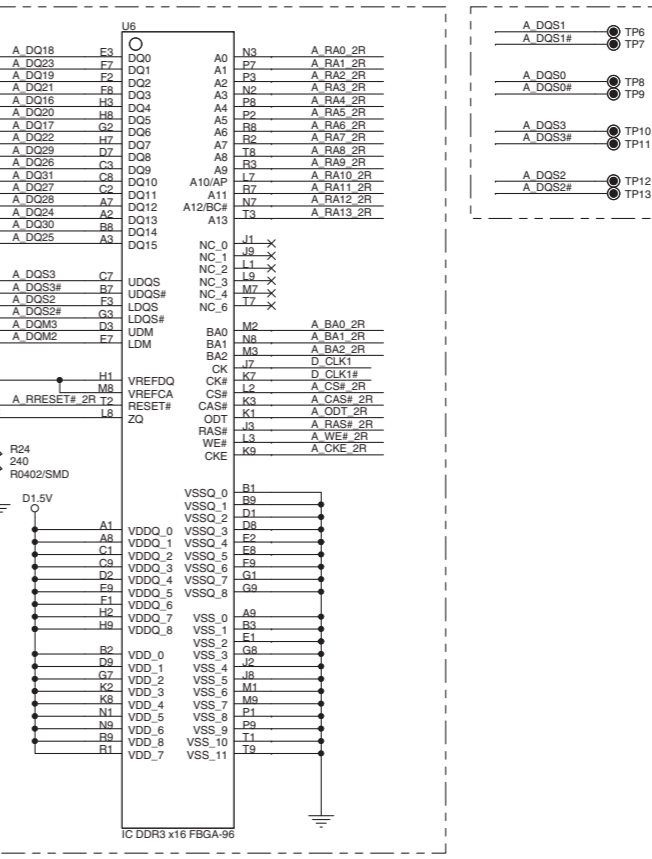
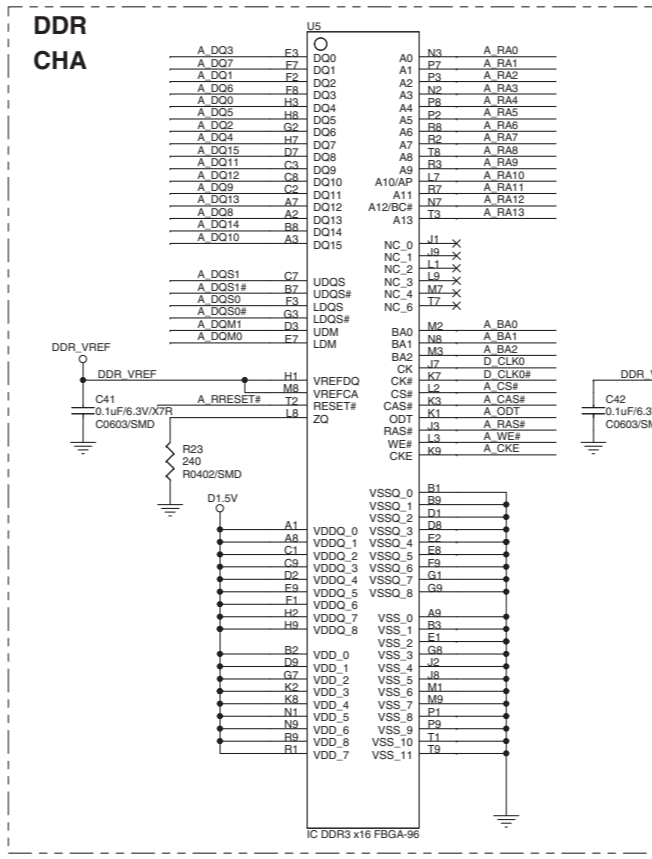
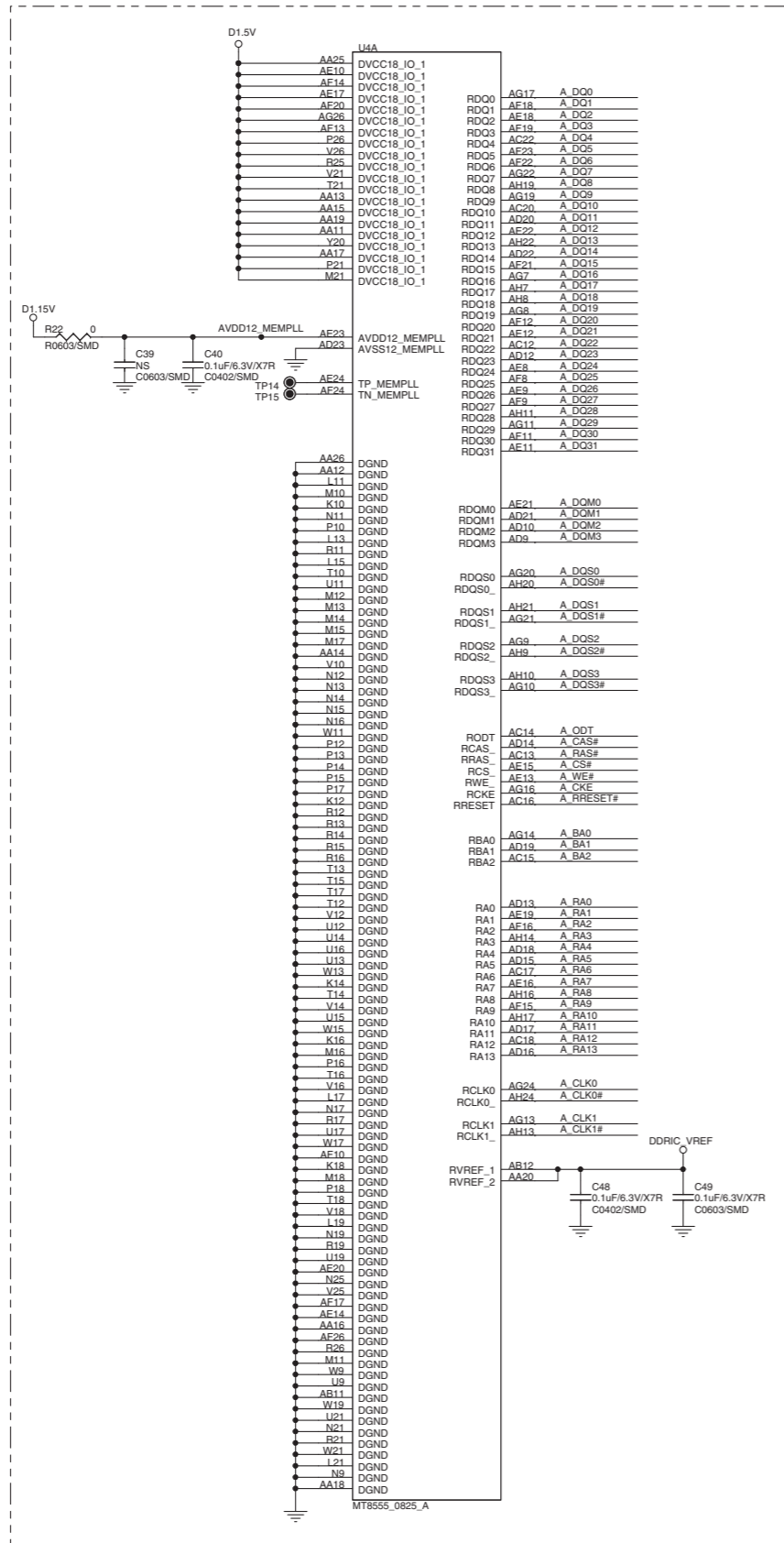

★ All voltages are measured with a 10MΩ/V DC electronic voltmeter.
 ★ Components having special characteristics are marked Δ and must be replaced with parts having specifications equal to those originally installed.
 ★ Schematic diagram is subject to change without notice.

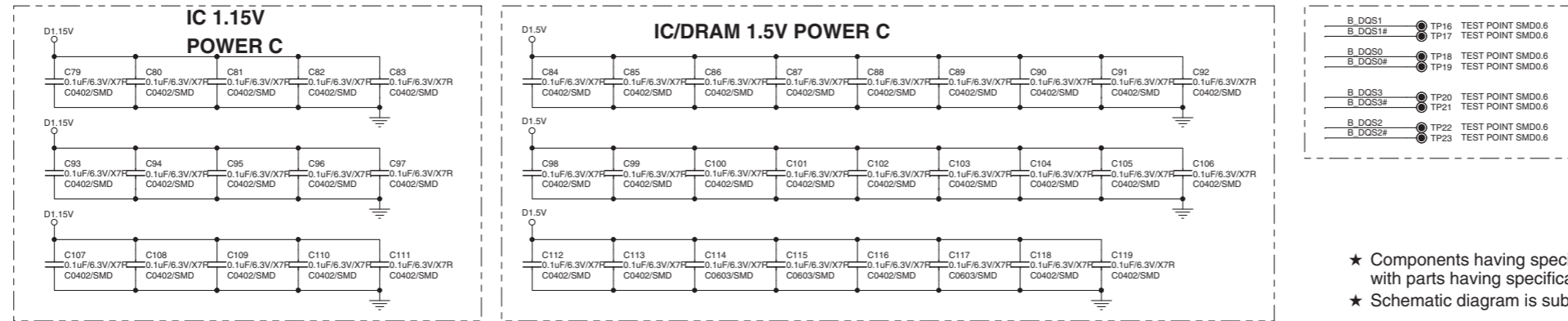
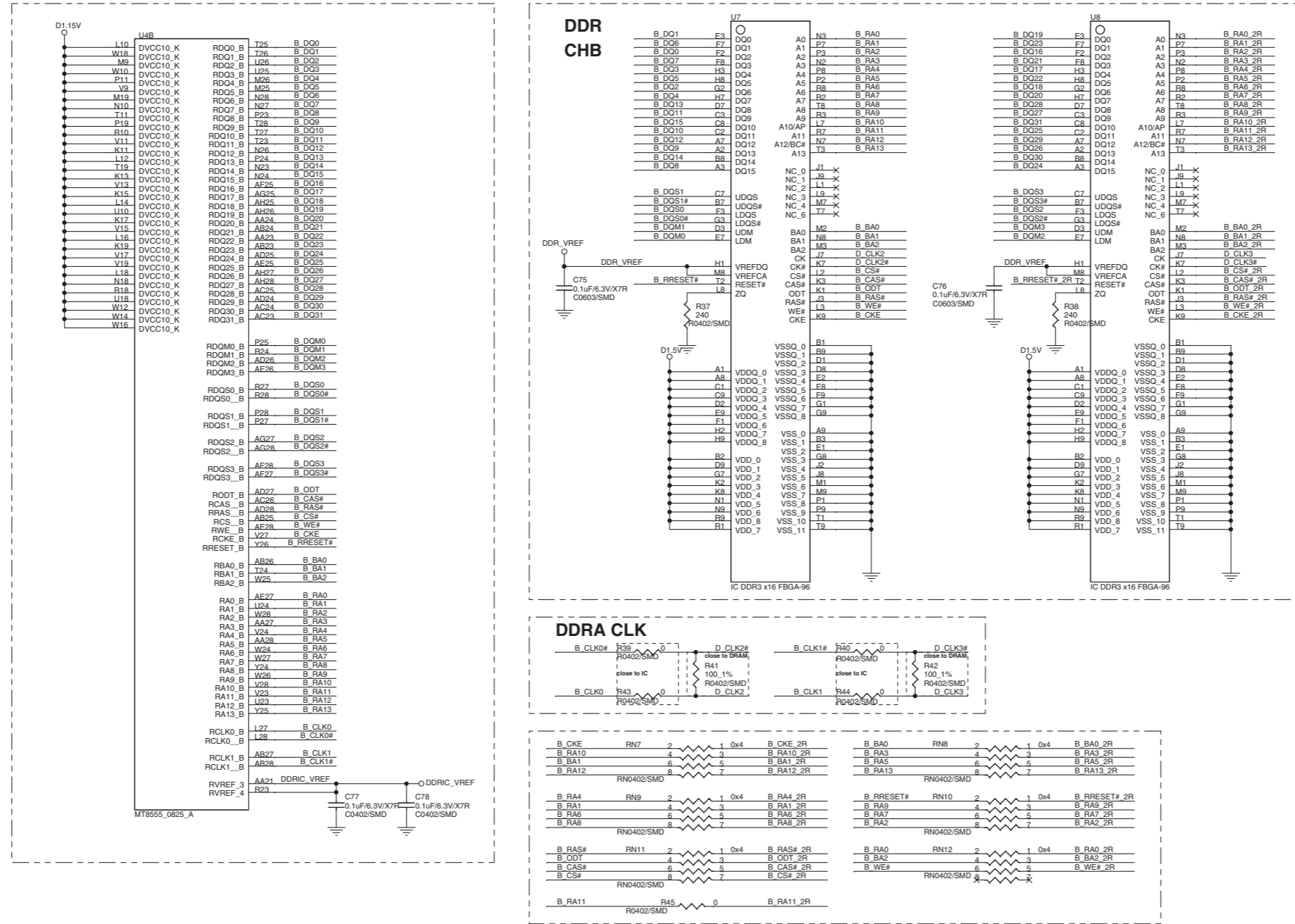

★ Components having special characteristics are marked Δ and must be replaced with parts having specifications equal to those originally installed.
 ★ Schematic diagram is subject to change without notice.

MAIN 4/14

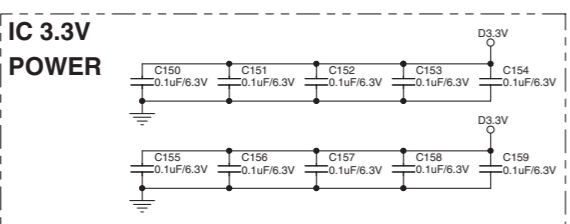
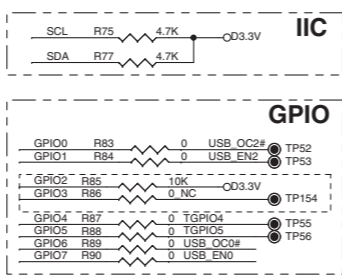
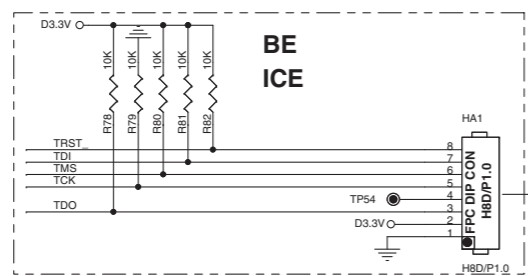
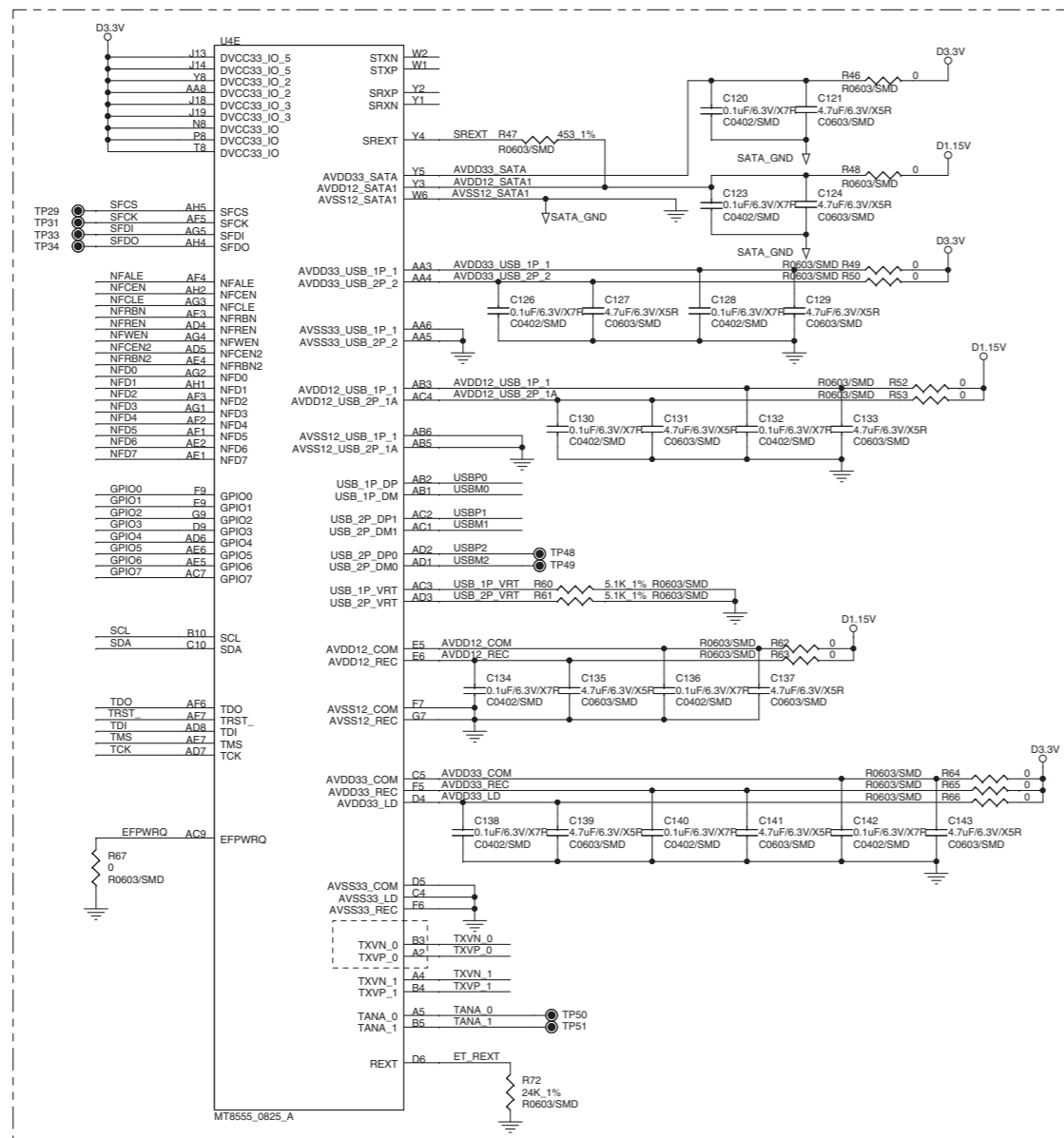

to BD mechanism unit

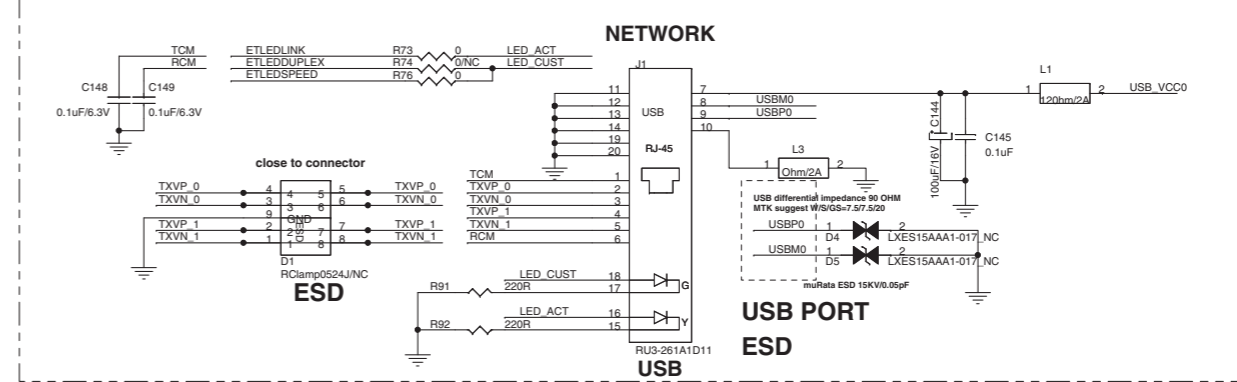
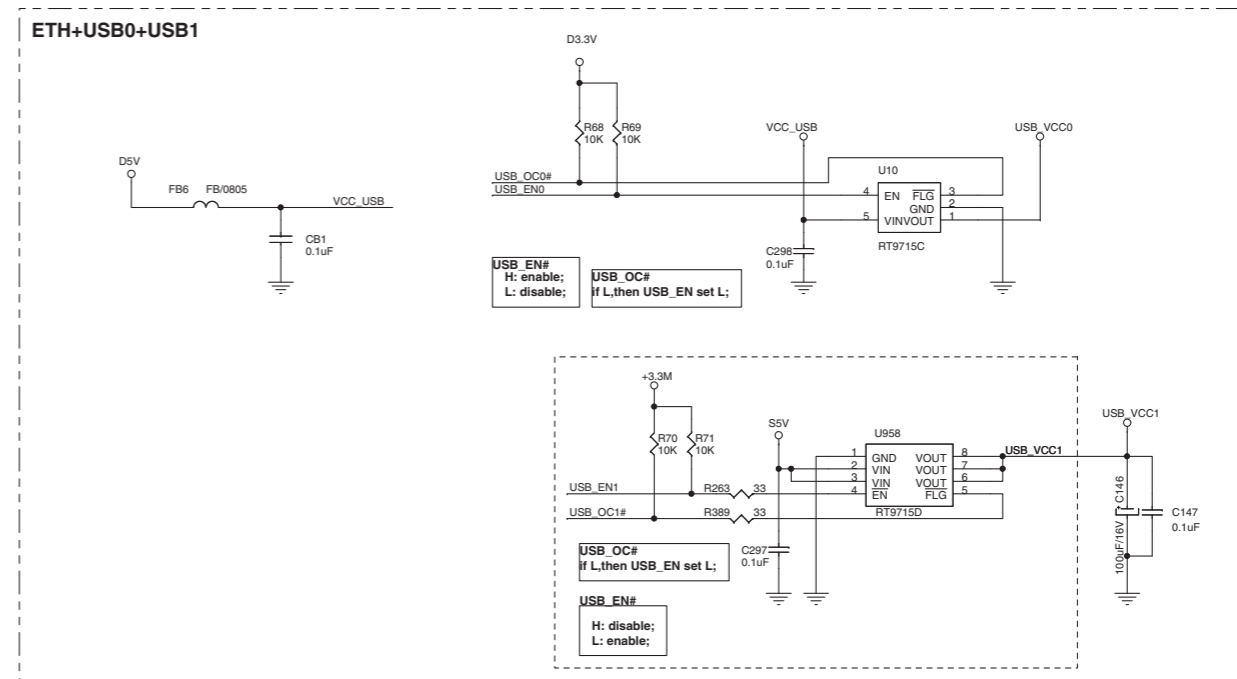
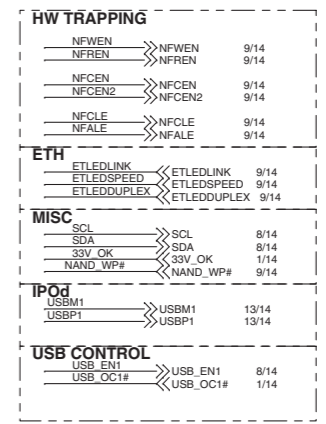
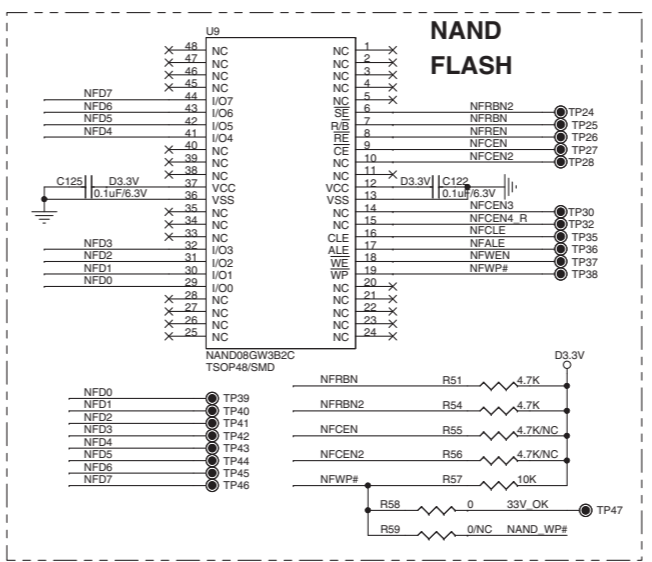

- ★ All voltages are measured with a 10MΩ/V DC electronic voltmeter.
- ★ Components having special characteristics are marked Δ and must be replaced with parts having specifications equal to those originally installed.
- ★ Schematic diagram is subject to change without notice.

MAIN 5/14

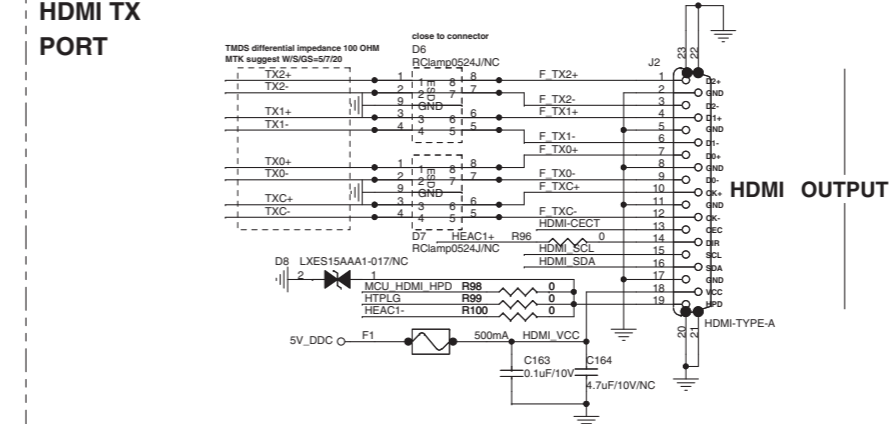
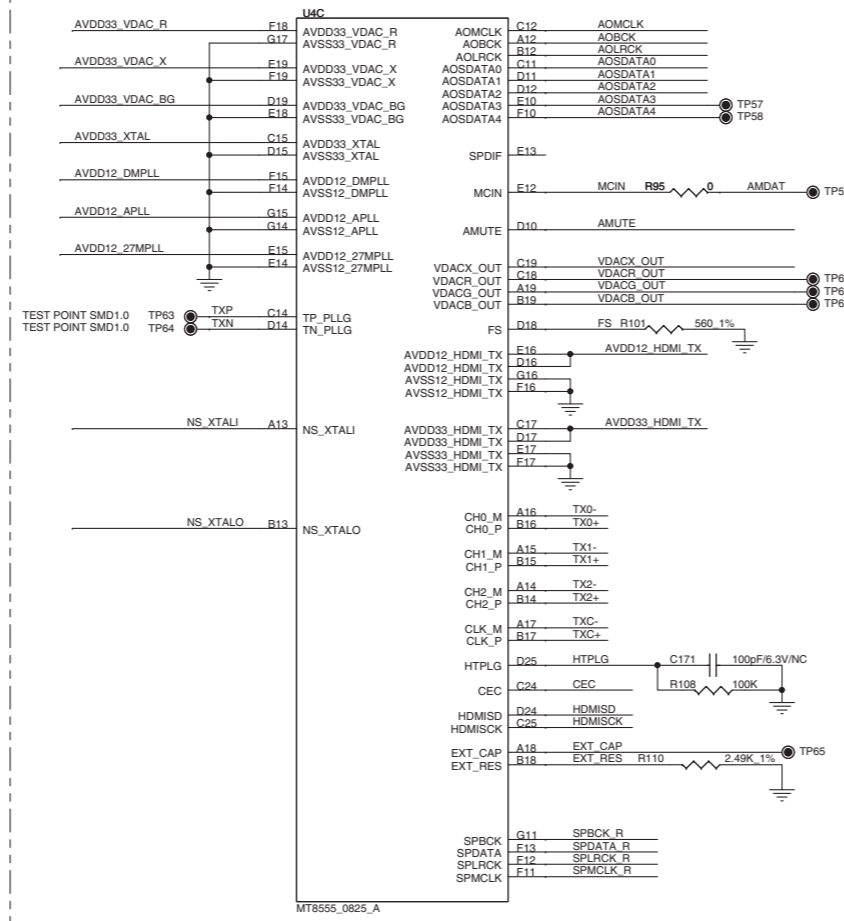
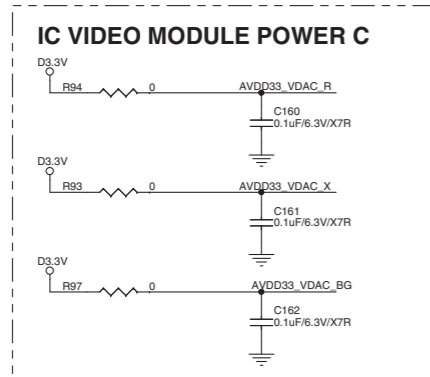

AUDIO I2S		
AOLRCK	>> AOLRCK	8/14, 9/14
AOBCK	>> AOBCK	8/14
AOMCLK	>> AOMCLK	8/14
AOSDATA2	>> AOSDATA2	8/14, 9/14
AOSDATA1	>> AOSDATA1	8/14, 9/14
AOSDATA0	>> AOSDATA0	8/14, 9/14
SPDIF		
SPMCLK	>> SPMCLK	8/14
SPLRCK	>> SPLRCK	8/14
SPBCK	>> SPBCK	8/14
SPDATA	>> SPDATA	8/14
VIDEO		
VDACX_OUT	>> VDACX_OUT	14/14
ARC		
ARC_MODE	>> ARC_MODE	6/14
COAX_ARC_OUT	>> COAX_ARC_OUT	6/14
MISC		
AMUTE	>> AMUTE	8/14, 9/14
HDMI_CEC		
HDMI-CECR	>> HDMI-CECR	7/14
MCU_HDMI_HPD	>> MCU_HDMI_HPD	12/14
MCU_HDMI_CEC	>> MCU_HDMI_CEC	9/14

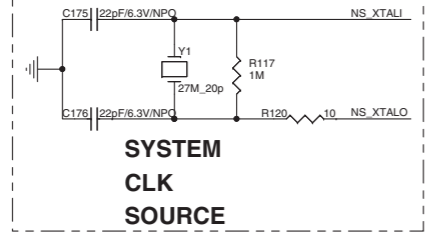
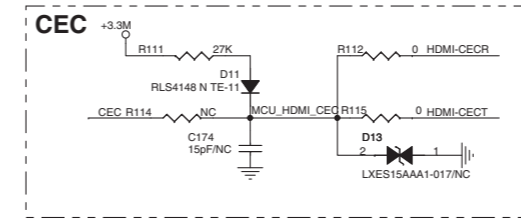
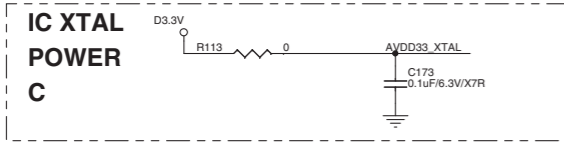
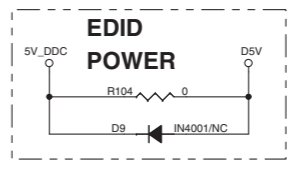
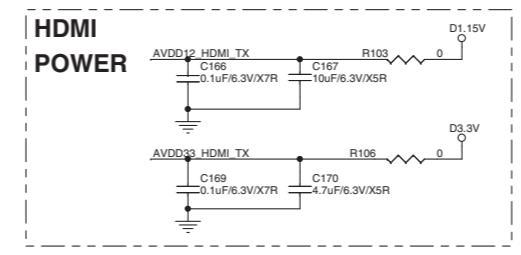
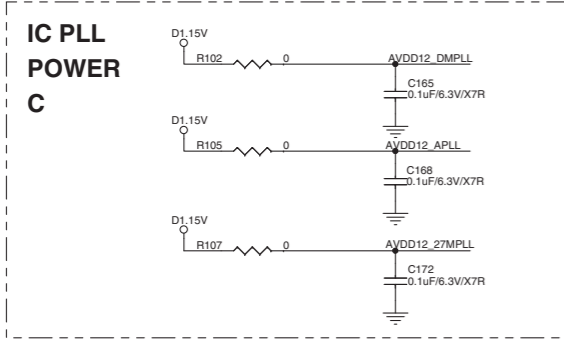

SPDIF IF

SPBCK_R	R119	0	SPBCK
SPDATA_R	R121	0	SPDATA
SPLRCK_R	R123	0	SPLRCK
SPMCLK_R	R124	0	SPMCLK

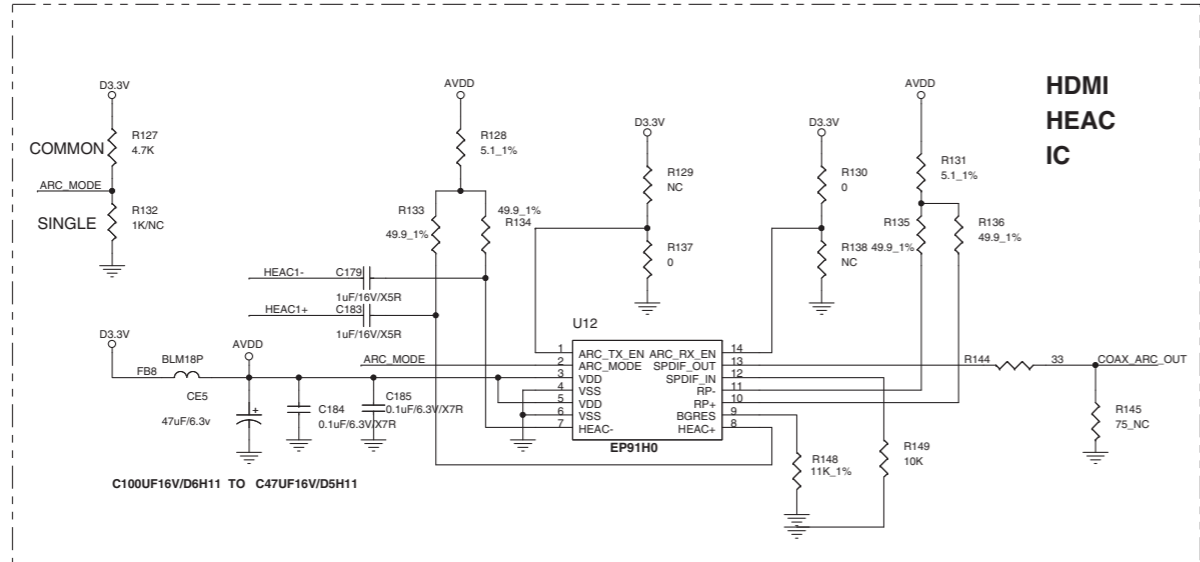
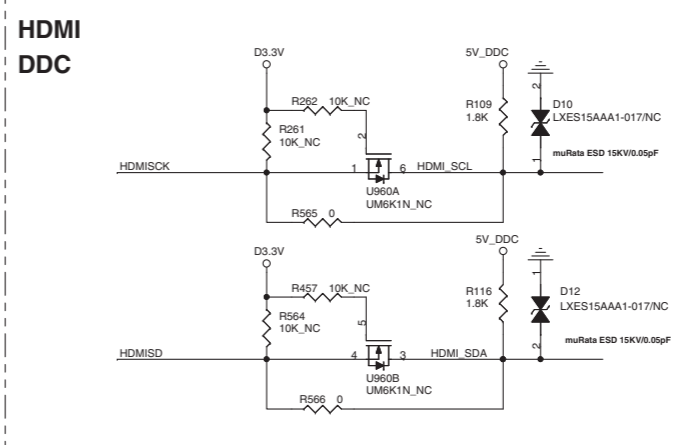
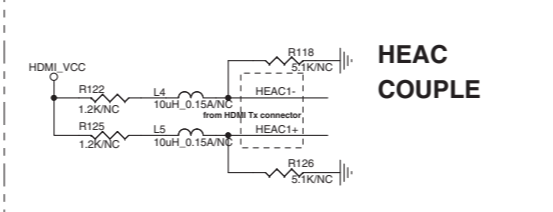

★ Components having special characteristics are marked Δ and must be replaced with parts having specifications equal to those originally installed.
★ Schematic diagram is subject to change without notice.

MAIN 6/14

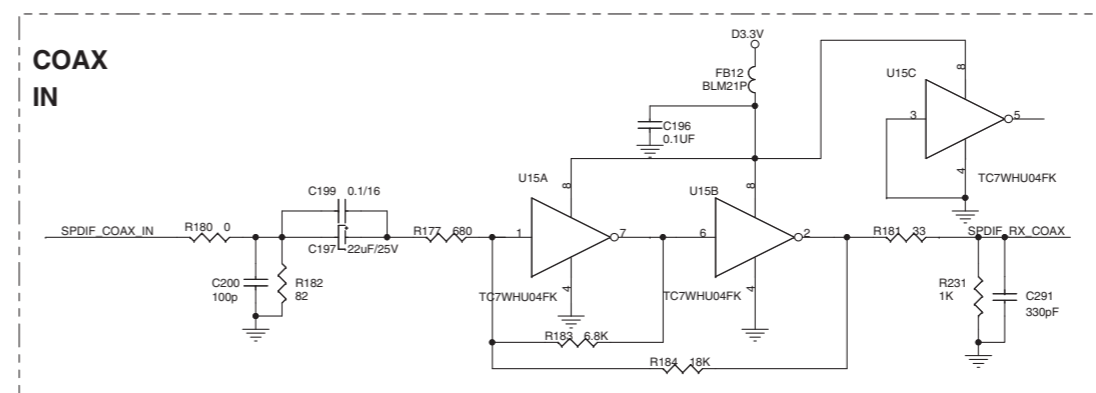
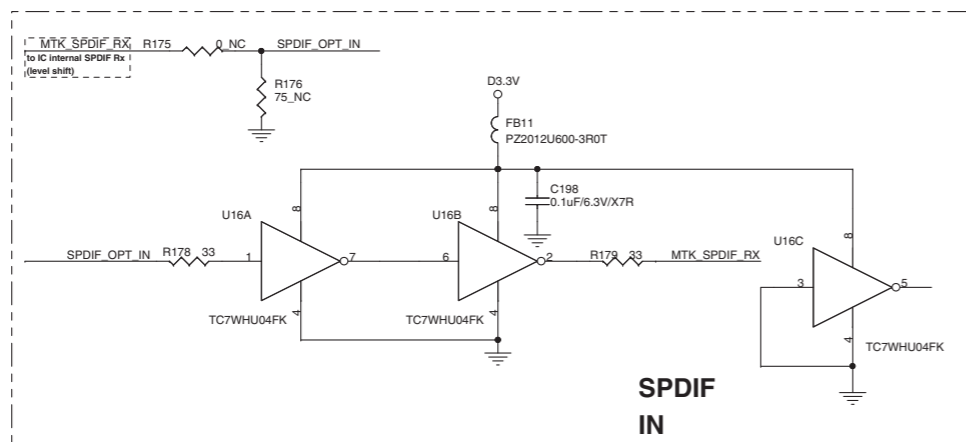
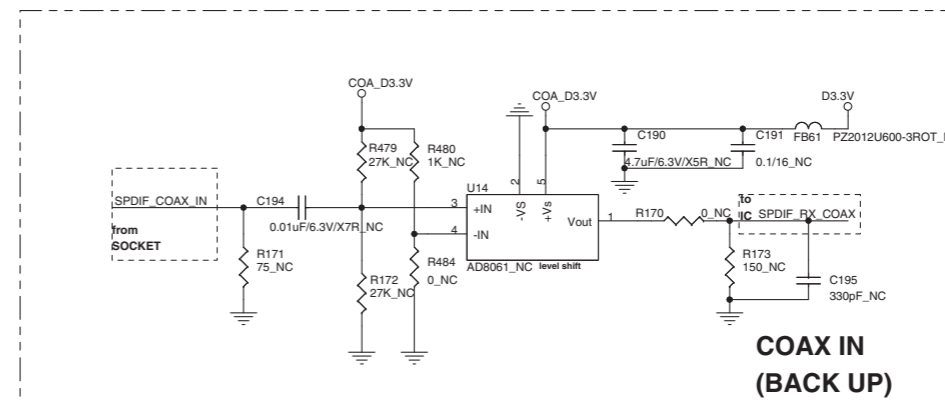
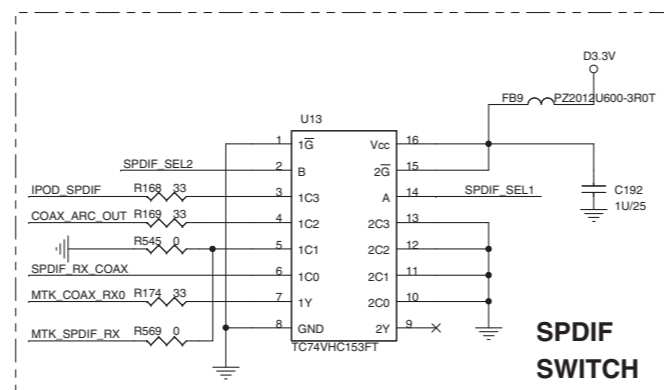
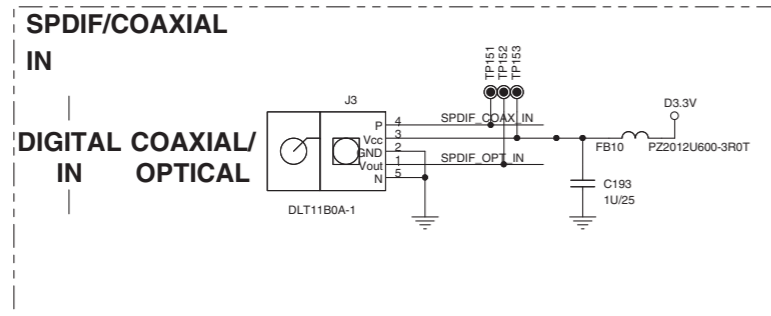
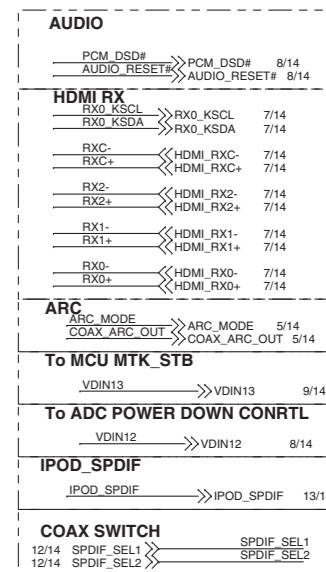
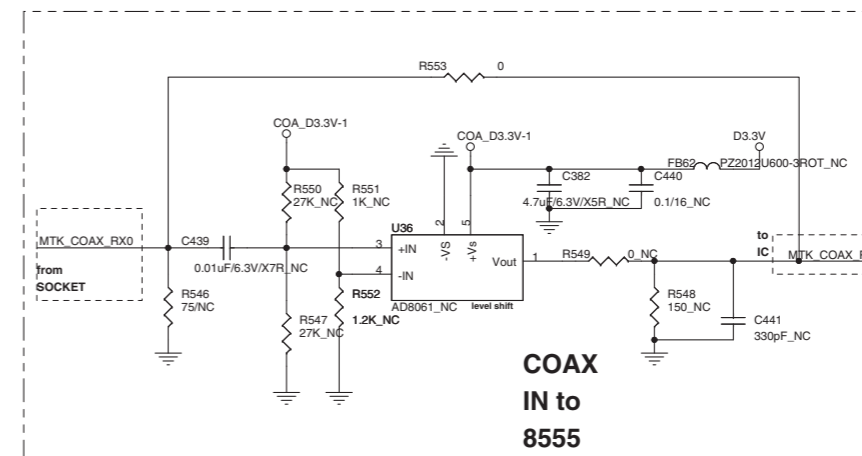
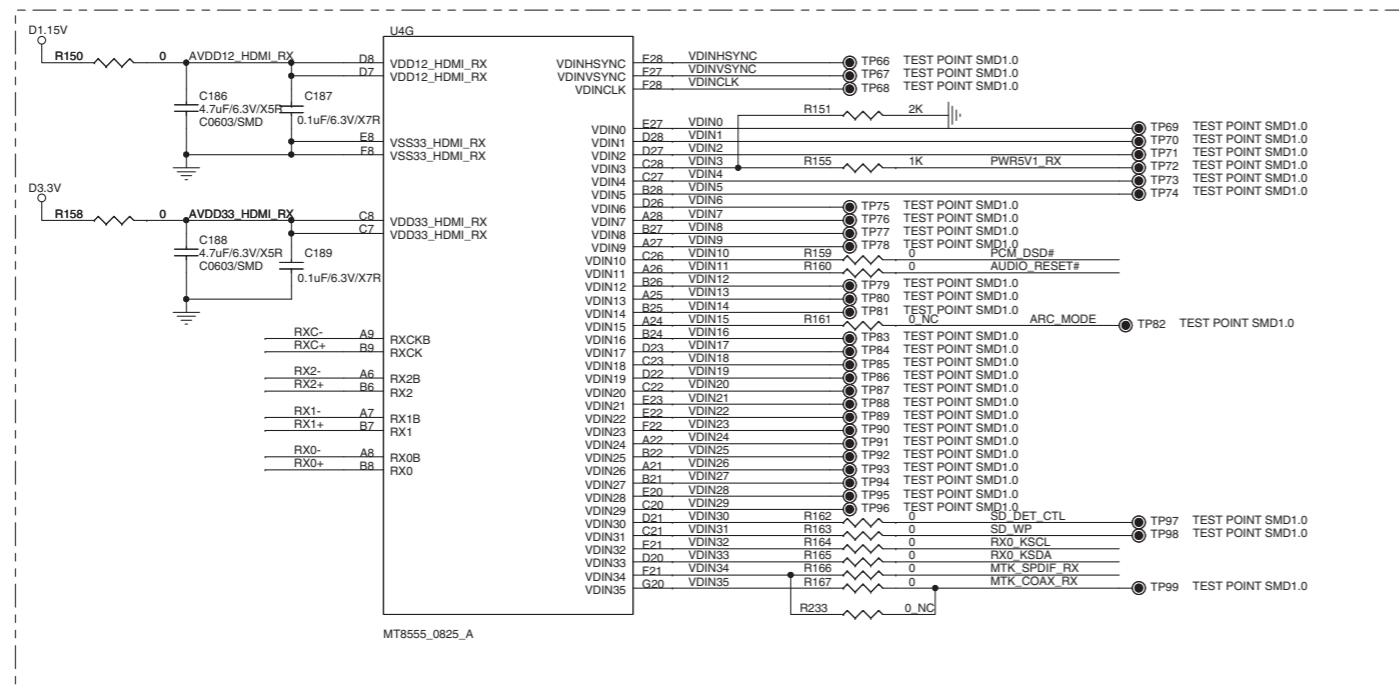

- ★ All voltages are measured with a 10MΩ/V DC electronic voltmeter.
- ★ Components having special characteristics are marked Δ and must be replaced with parts having specifications equal to those originally installed.
- ★ Schematic diagram is subject to change without notice.

MAIN 7/14

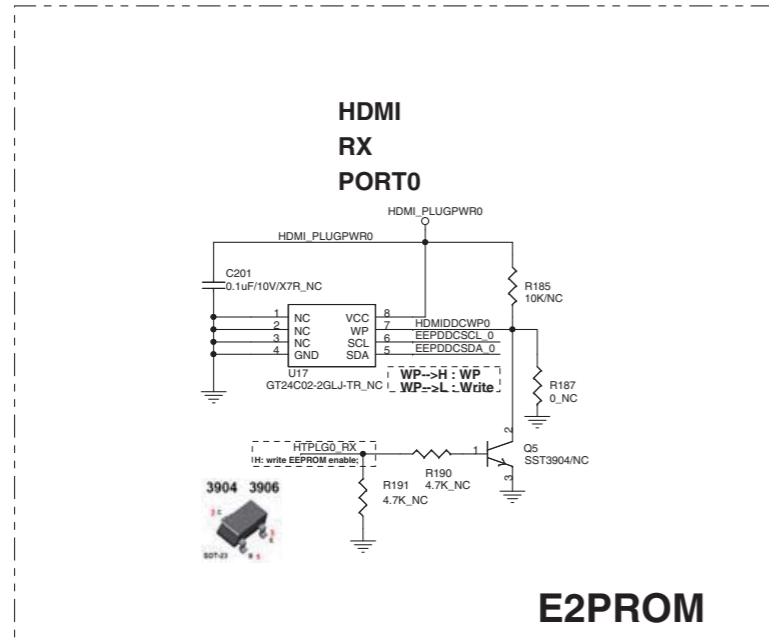

E2PROM

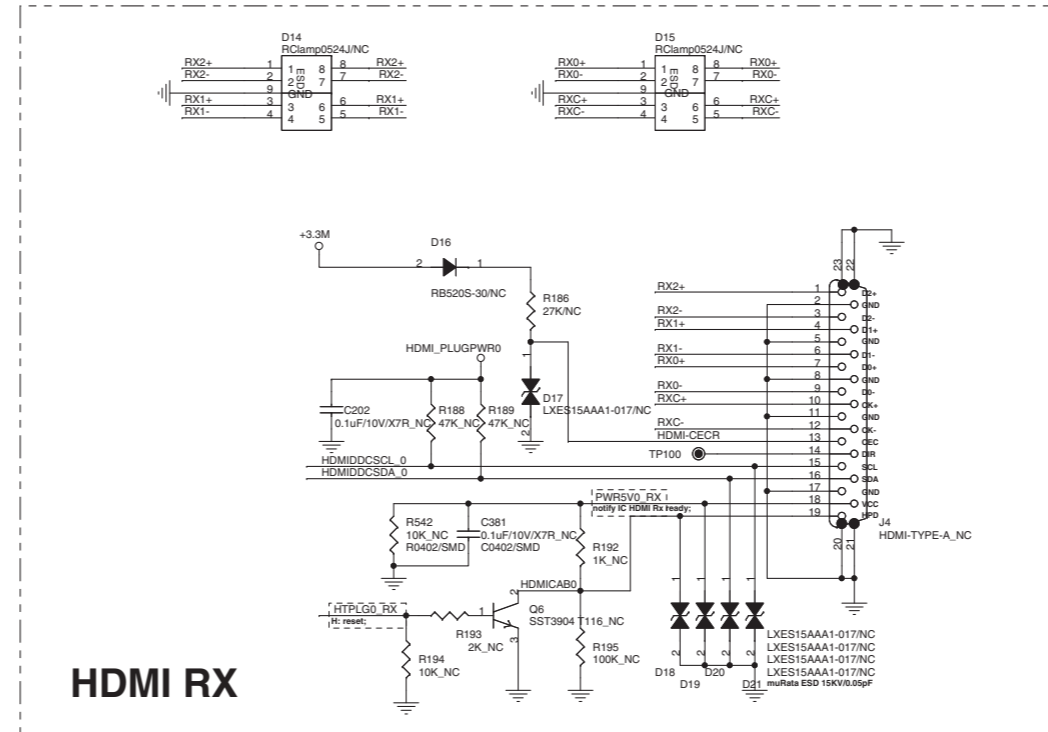

HDMI RX

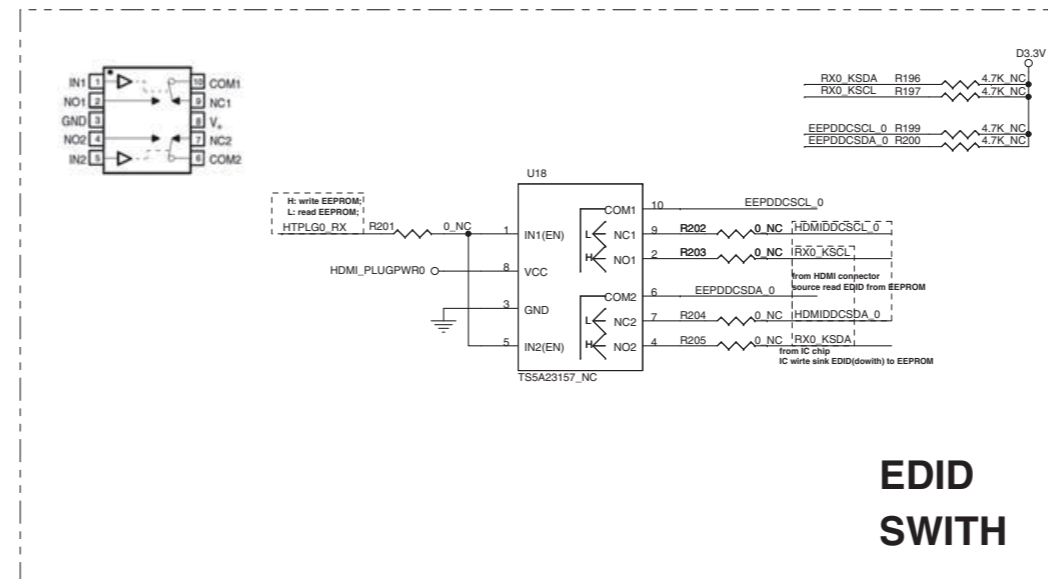
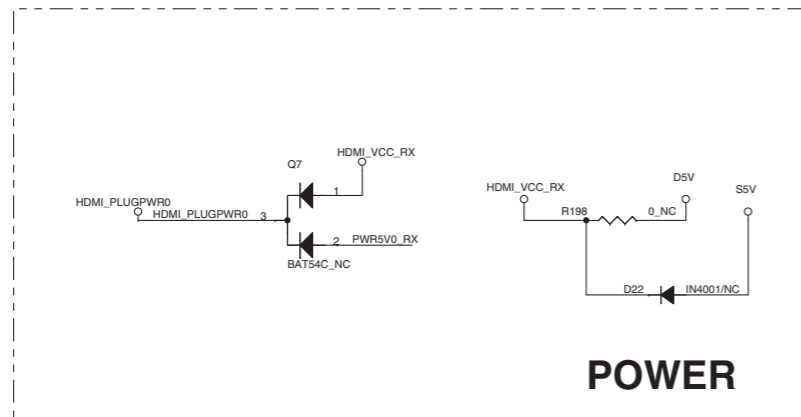
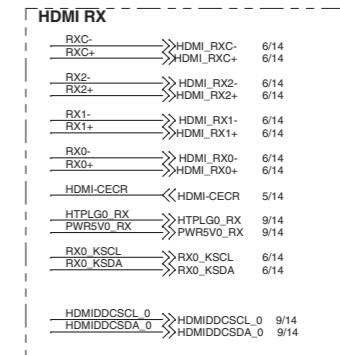

★ Components having special characteristics are marked Δ and must be replaced with parts having specifications equal to those originally installed.
 ★ Schematic diagram is subject to change without notice.

MAIN 8/14

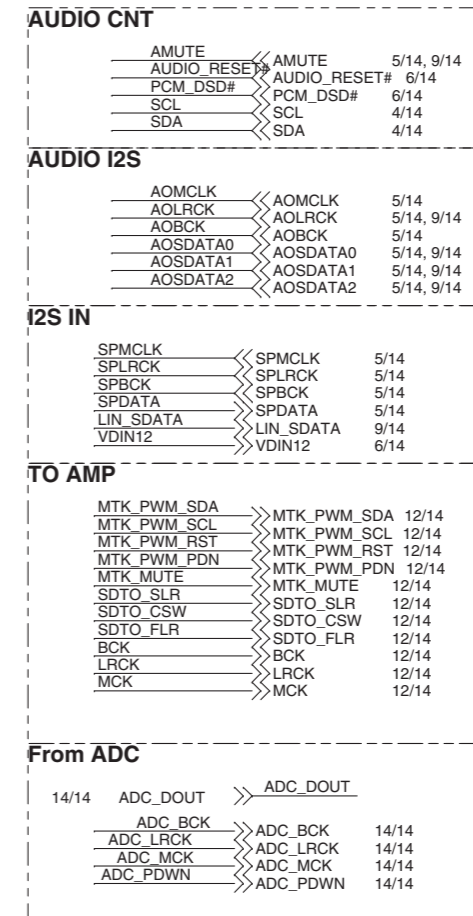
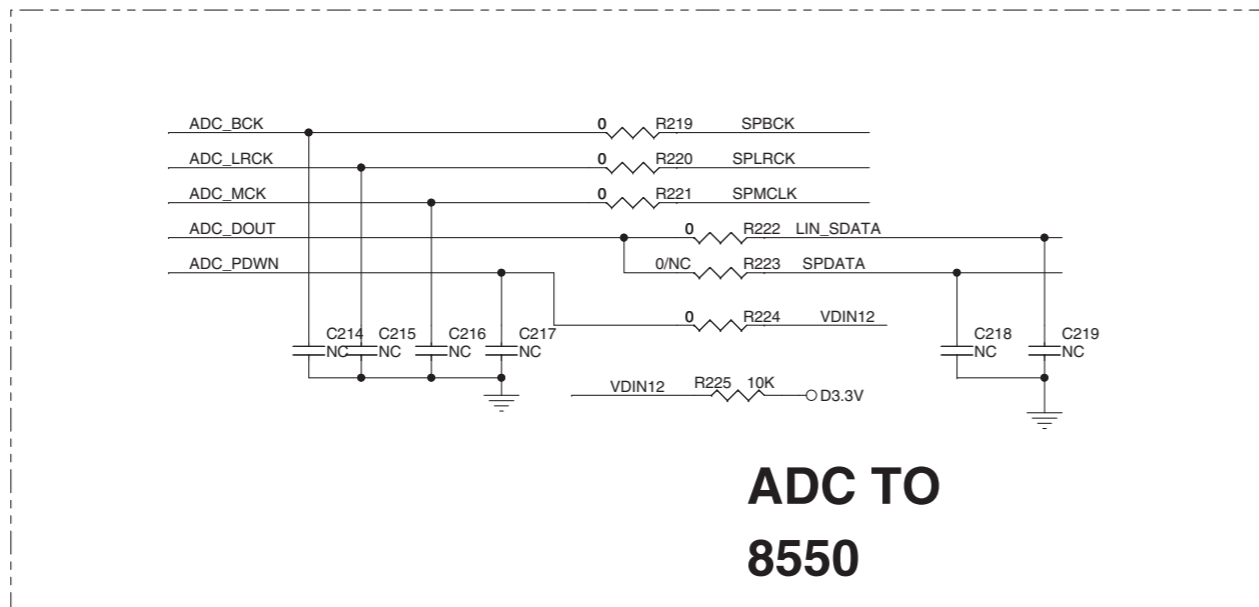
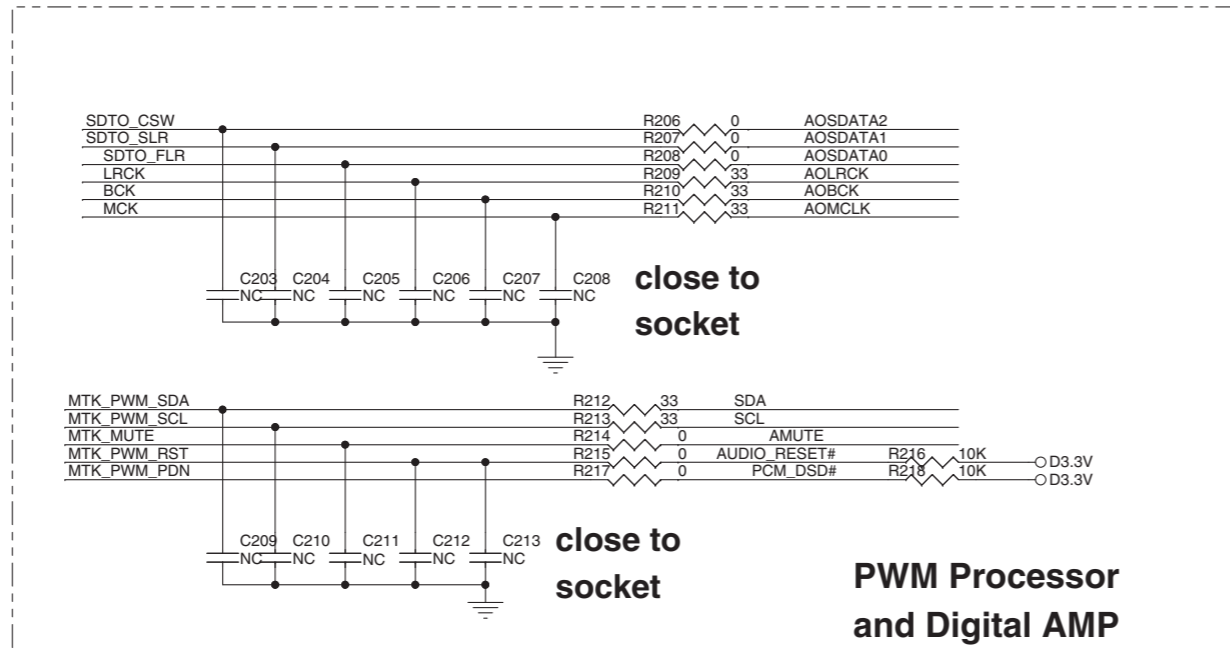

★ All voltages are measured with a 10MΩ/V DC electronic voltmeter.
 ★ Components having special characteristics are marked Δ and must be replaced with parts having specifications equal to those originally installed.
 ★ Schematic diagram is subject to change without notice.

MAIN 9/14

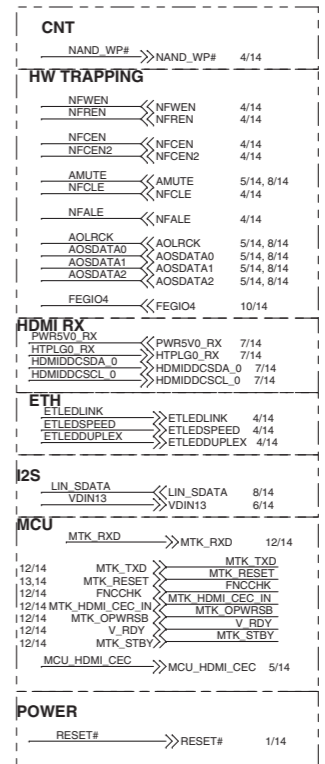
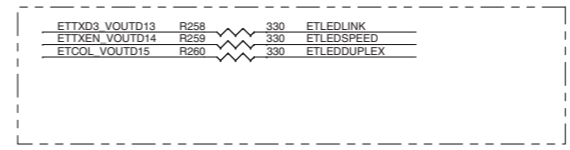
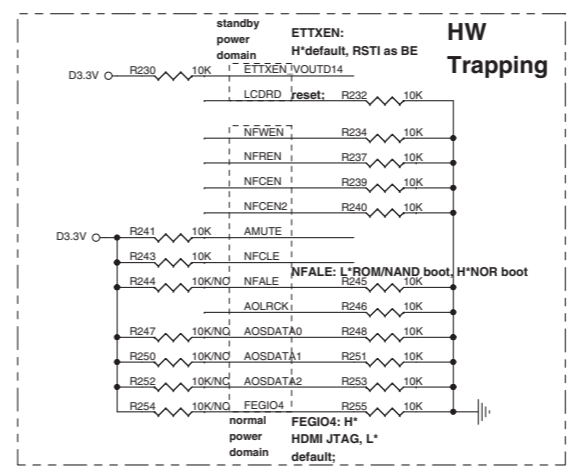
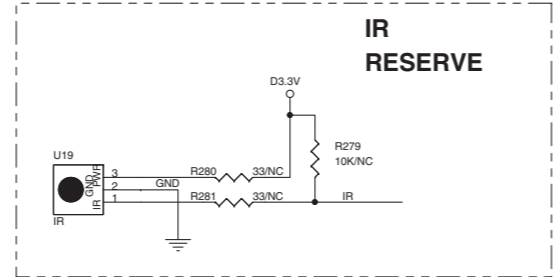
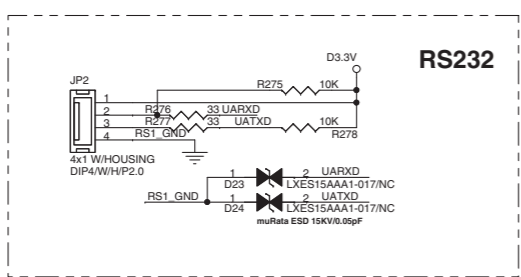
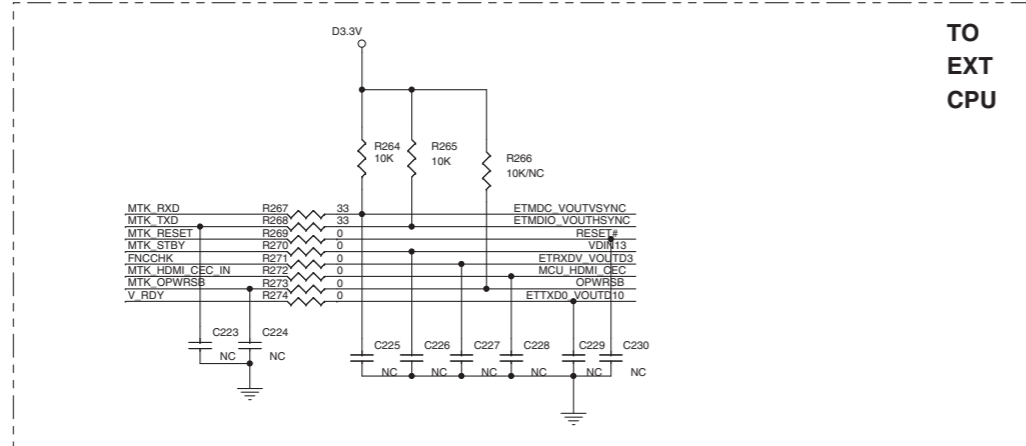
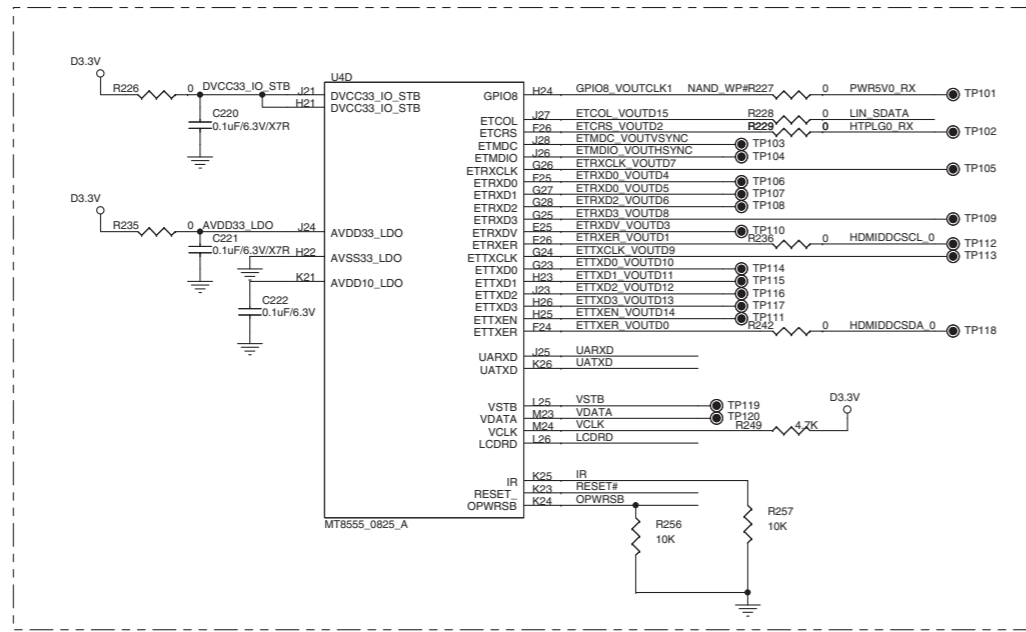

Signal name	Ball	HW trapping	Note	
AMUTE	D10	0: Default (ICE disable)	Normal power domain	
		1: Main RISC ICE enable		
FEGIO4	T3	JTAG_TRAP		
		0: Default		1: HDMI
NFCEN2	AD5	00: Normal mode (Default)		
NFCEN	AH2			
NFWEN	AG4	0: Default		1: OLT Test Mode
NFALE	AF4	0: Default		1: FLASH boot
AOLRCK	B12	XTL_REF_SEL		1: VCXO
NFCLE	AG3	0: Old NFI		1: new NFI (Default)
NFREN	AD4	0: Default	1: ABIST mode	
AOSDATA0	C11	Reserved trapping 000: (Default)		
AOSDATA1	D11			
AOSDATA2	D12			
ETTXEN	H25	LCDRD, ETTXEN=01:	Standby power domain	
LCDRD	L26	Normal mode (Default)		

★ Components having special characteristics are marked Δ and must be replaced with parts having specifications equal to those originally installed.
 ★ Schematic diagram is subject to change without notice.

MAIN 10/14

to BD mechanism unit

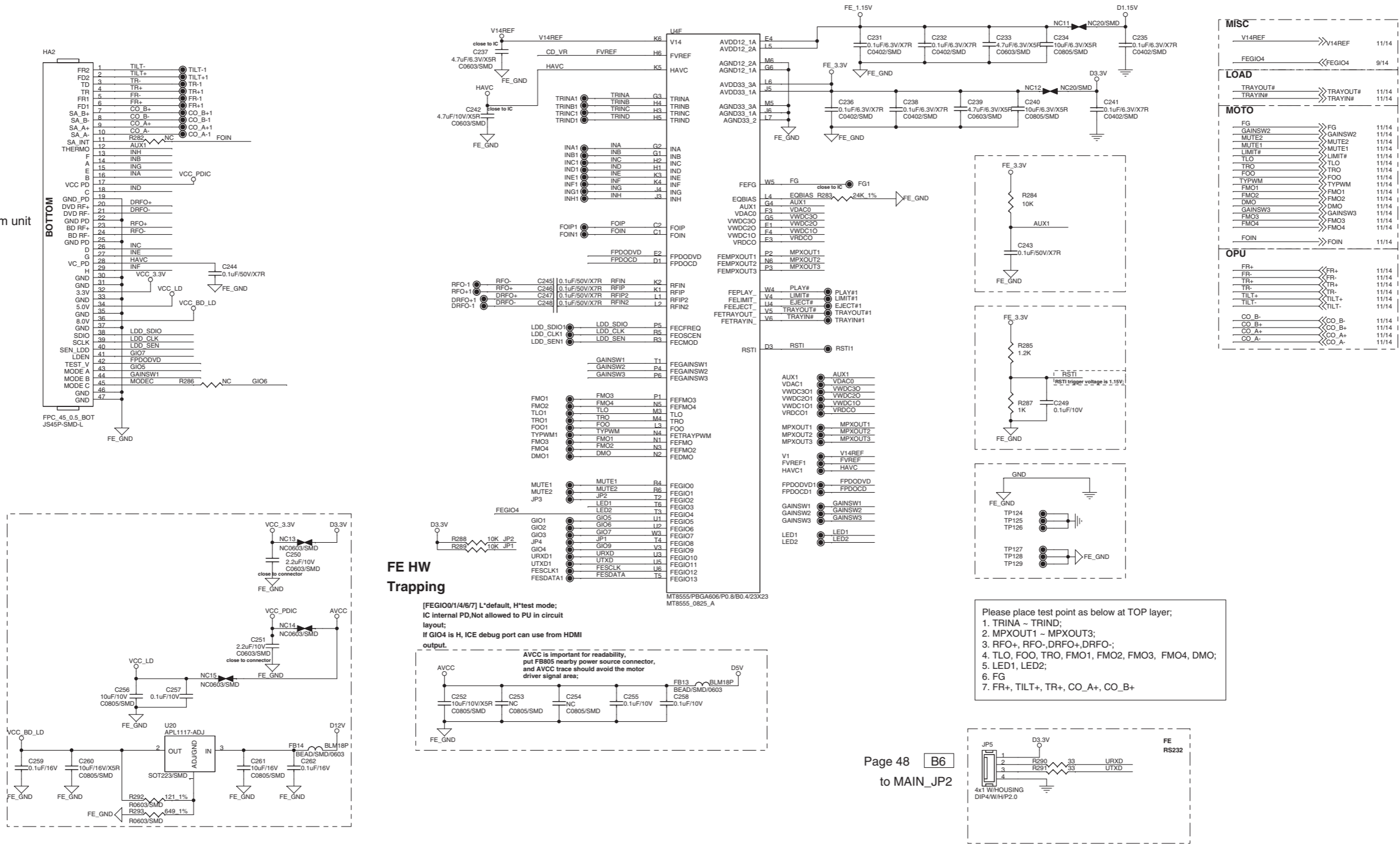

Page 48 B6 to MAIN_JP2

★ All voltages are measured with a 10MΩ/V DC electronic voltmeter.
 ★ Components having special characteristics are marked Δ and must be replaced with parts having specifications equal to those originally installed.
 ★ Schematic diagram is subject to change without notice.

MAIN 11/14

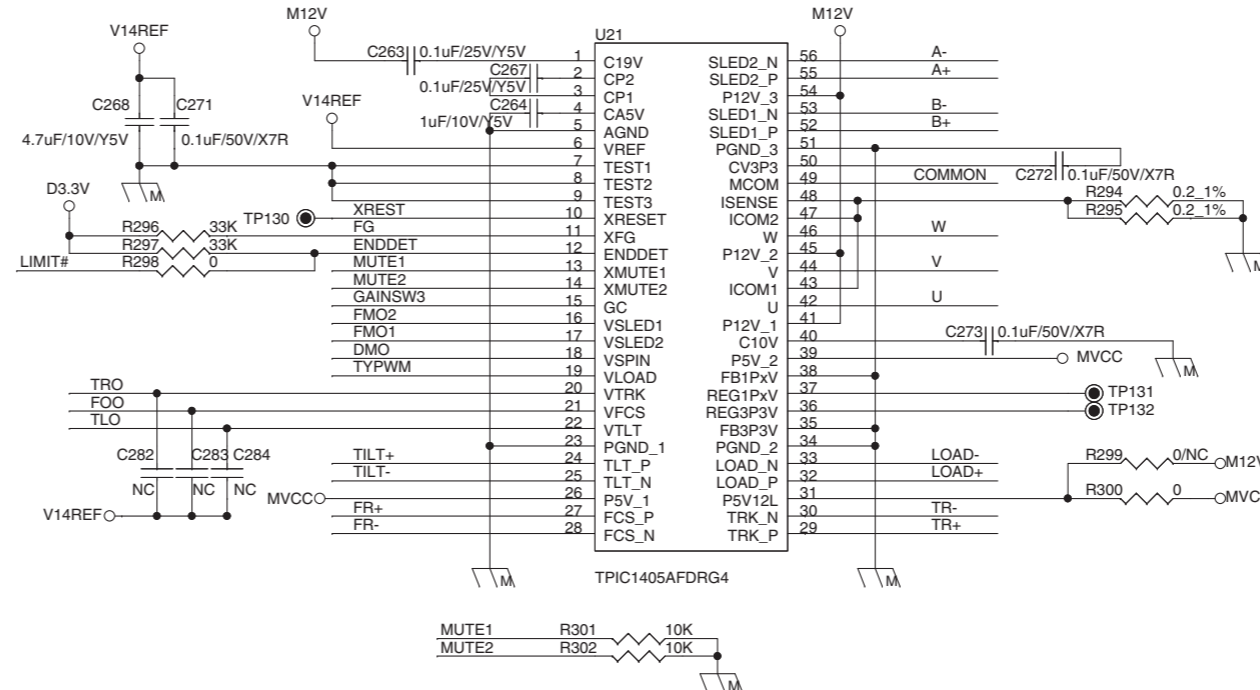
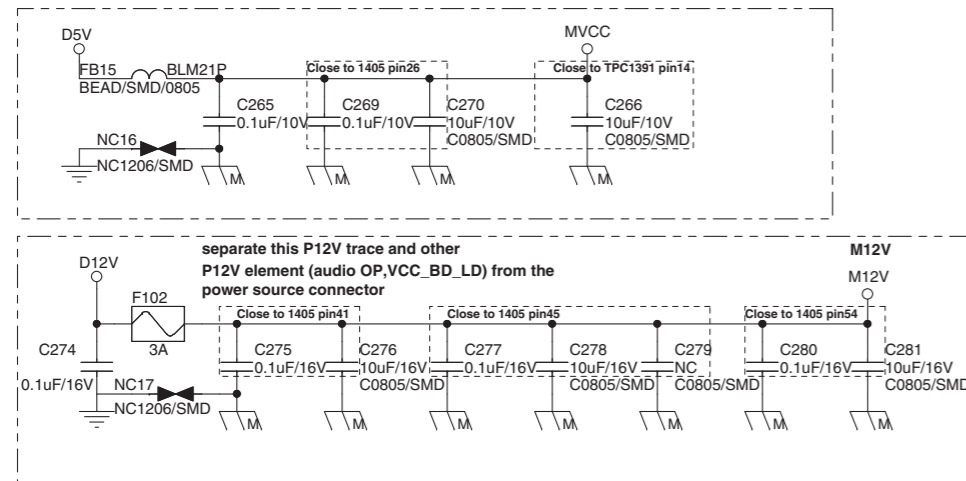

OPU		
TR+	TR+	10/14
TR-	TR-	10/14
FR+	FR+	10/14
FR-	FR-	10/14
TILT+	TILT+	10/14
TILT-	TILT-	10/14
CO_B-	CO_B-	10/14
CO_B+	CO_B+	10/14
CO_A+	CO_A+	10/14
CO_A-	CO_A-	10/14

MOTOR		
FMO4	FMO4	10/14
FMO3	FMO3	10/14
FOO	FOO	10/14
TRO	TRO	10/14
FMO2	FMO2	10/14
FMO1	FMO1	10/14
DMO	DMO	10/14
TLO	TLO	10/14
TYPWM	TYPWM	10/14
GAINSW3	GAINSW3	10/14
GAINSW2	GAINSW2	10/14

TRAYIN#	TRAYIN#	10/14
TRAYOUT#	TRAYOUT#	10/14
FG	FG	10/14
MUTE2	MUTE2	10/14
MUTE1	MUTE1	10/14
LIMIT#	LIMIT#	10/14
FOIN	FOIN	10/14
V14REF	V14REF	10/14

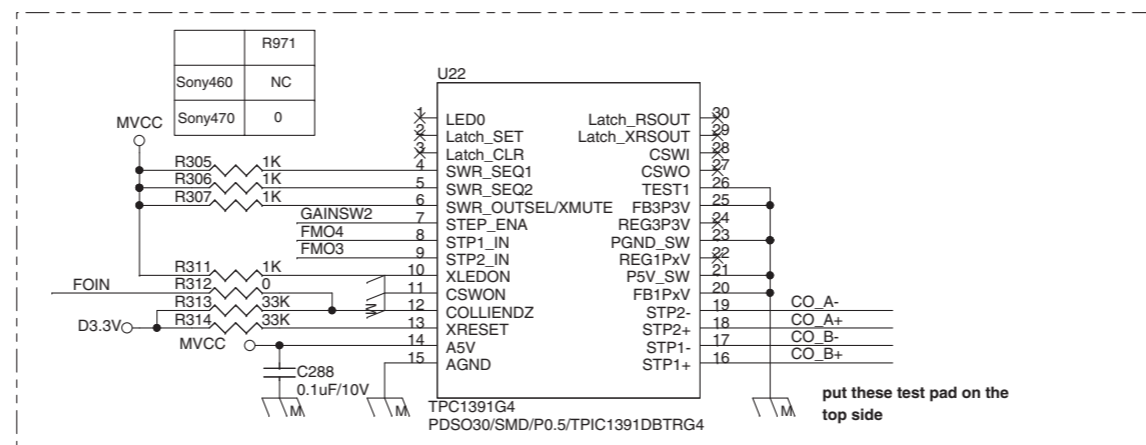
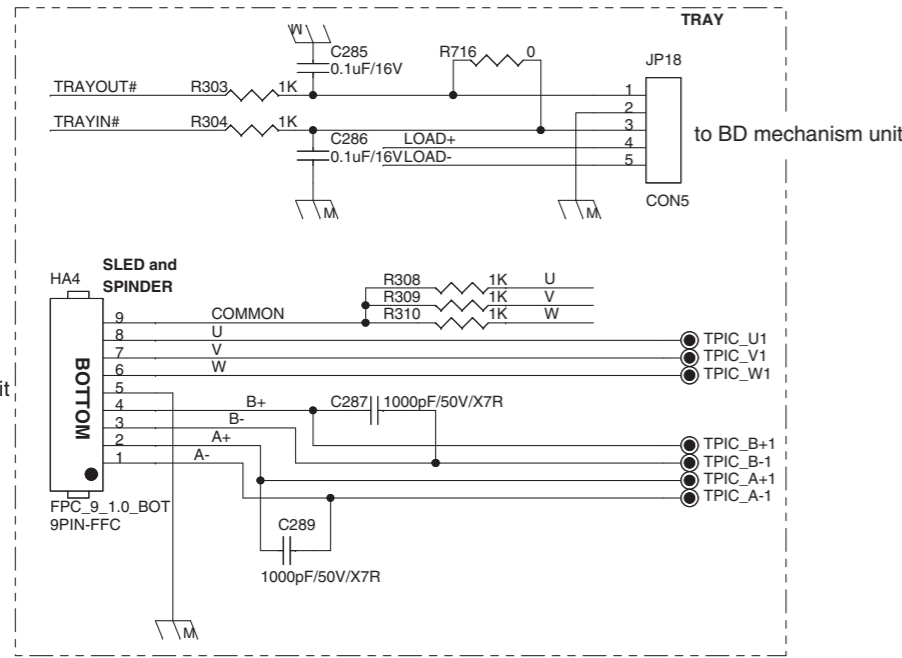

★ Components having special characteristics are marked Δ and must be replaced with parts having specifications equal to those originally installed.
 ★ Schematic diagram is subject to change without notice.

MAIN 12/14

to PSU_CON201

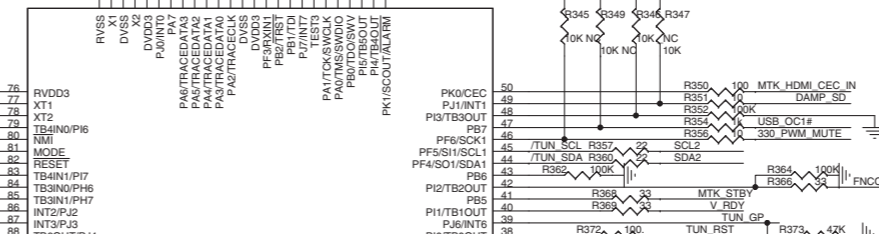
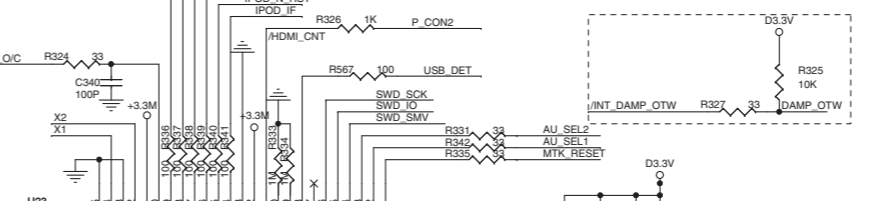
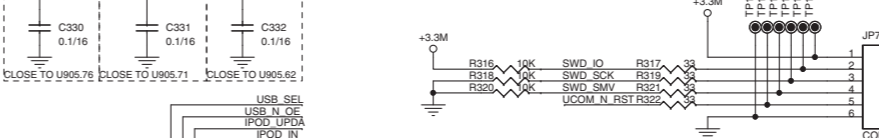
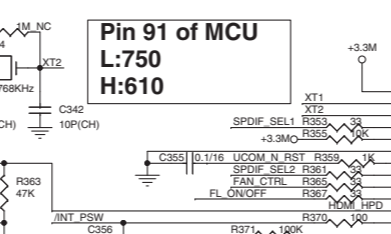
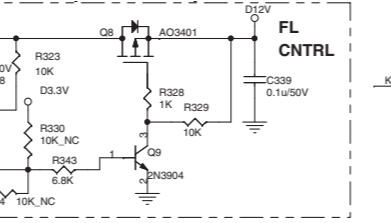
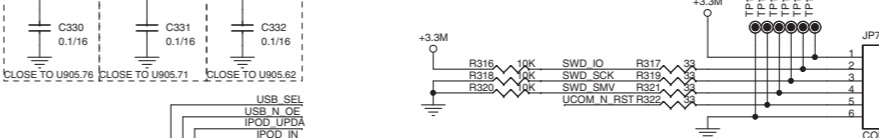
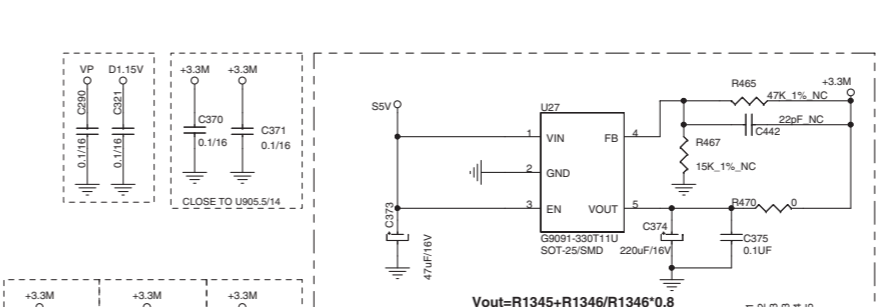
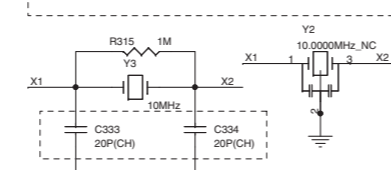
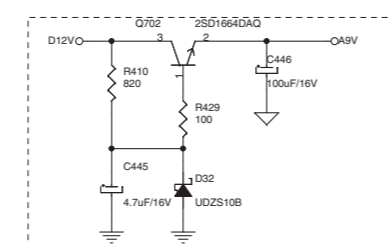
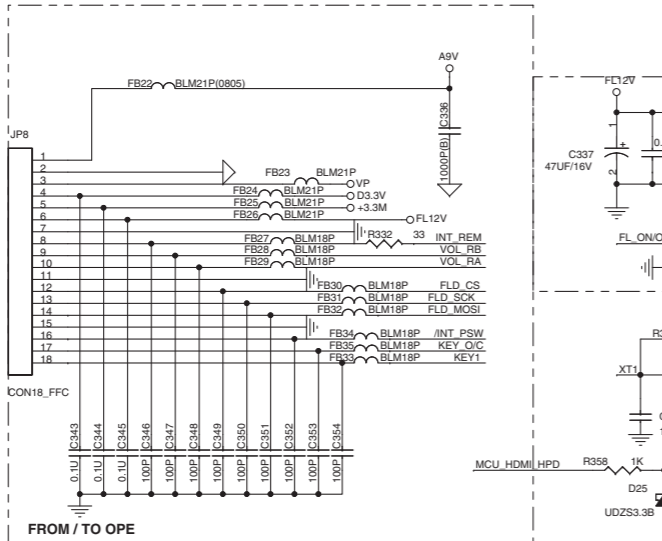
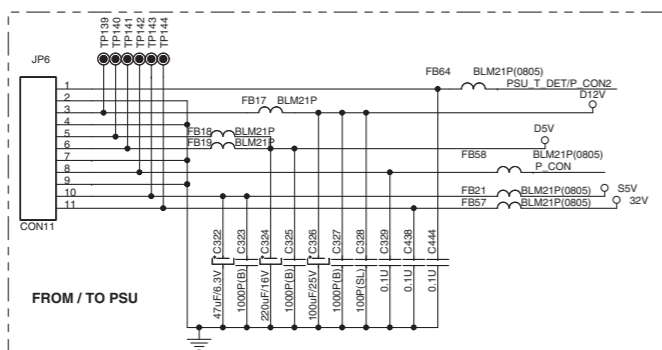

(for factory)

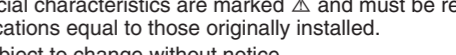
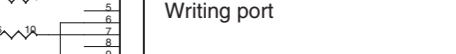
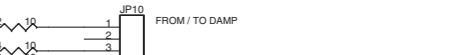
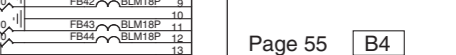
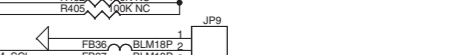
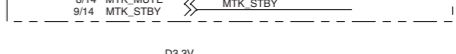
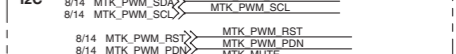
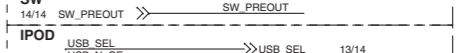
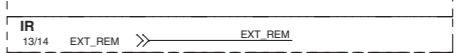
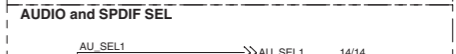
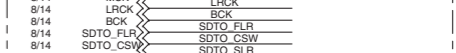
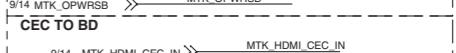
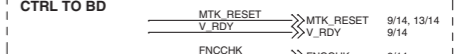
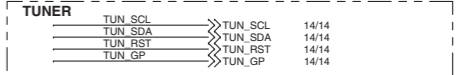

Page 54 B2 to OPERATION_JP701

Page 55 B4 to AMP_JP704

- ★ All voltages are measured with a 10MΩ/V DC electronic voltmeter.
- ★ Components having special characteristics are marked Δ and must be replaced with parts having specifications equal to those originally installed.
- ★ Schematic diagram is subject to change without notice.

MAIN 13/14

REMOTE CONTROL

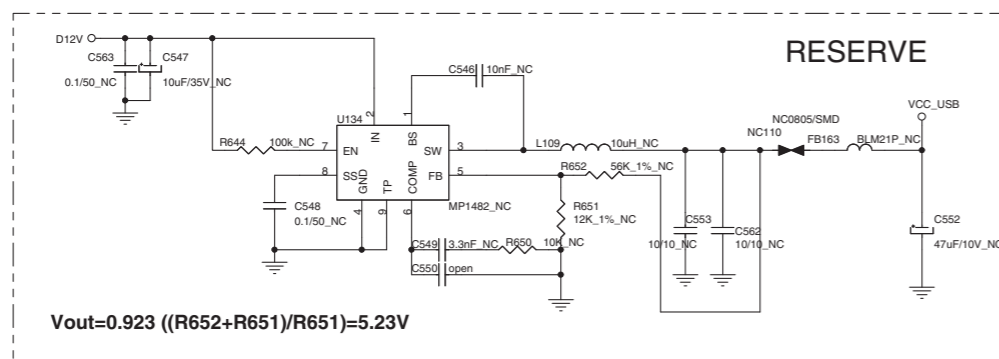
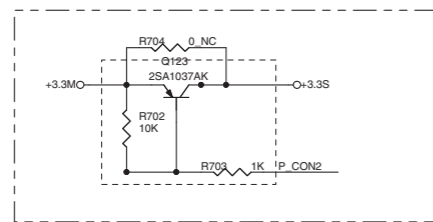
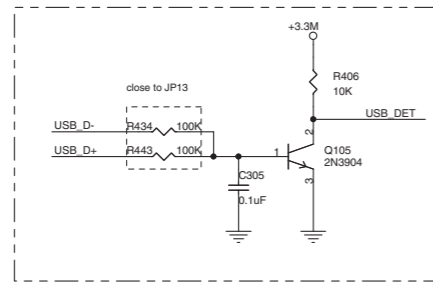
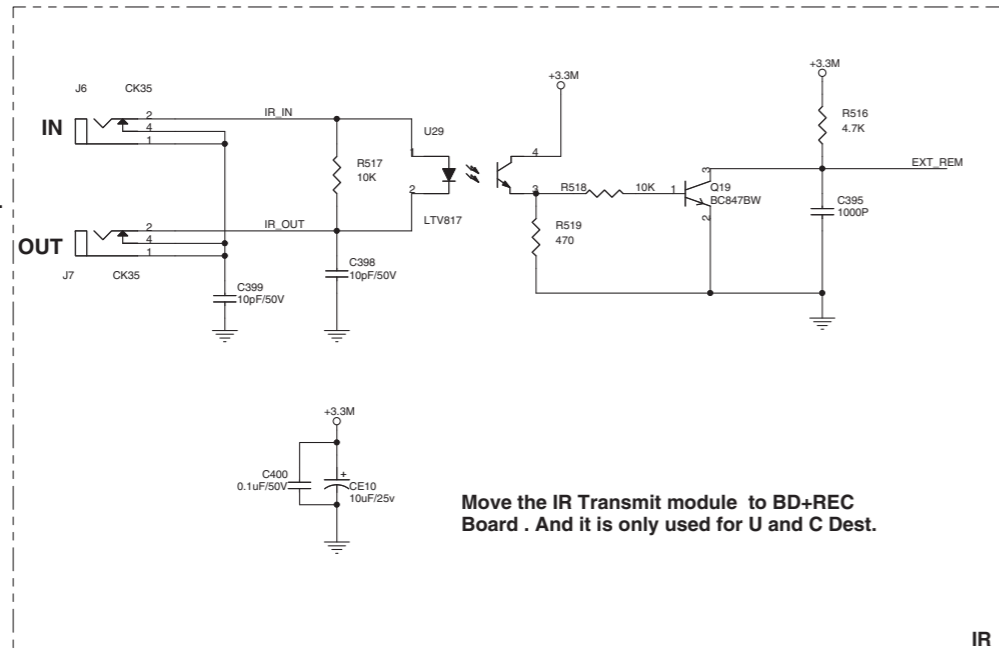

IR		
EXT REM	EXT_REM	12/14
IPOD		
USB_SEL	USB_SEL	12/14
USB_N_OE	USB_N_OE	12/14
IPOD_UPDA	IPOD_UPDA	12/14
IPOD_IN	IPOD_IN	12/14
IPOD_N_RST	IPOD_N_RST	12/14
IPOD_IF	IPOD_IF	12/14
IPOD_RX	IPOD_RX	12/14
IPOD_TX	IPOD_TX	12/14
IPOD_SPDIF	IPOD_SPDIF	6/14
MTK_RESET	MTK_RESET	9/14, 12/14
DIT_CS	DIT_CS	12/14
FLD_SCK	FLD_SCK	12/14
FLD_MOSI	FLD_MOSI	12/14
USBM1	USBM1	4/14
USBP1	USBP1	4/14
USB_DET		
USB_DET	USB_DET	12/14
P_CON2	P_CON2	12/14

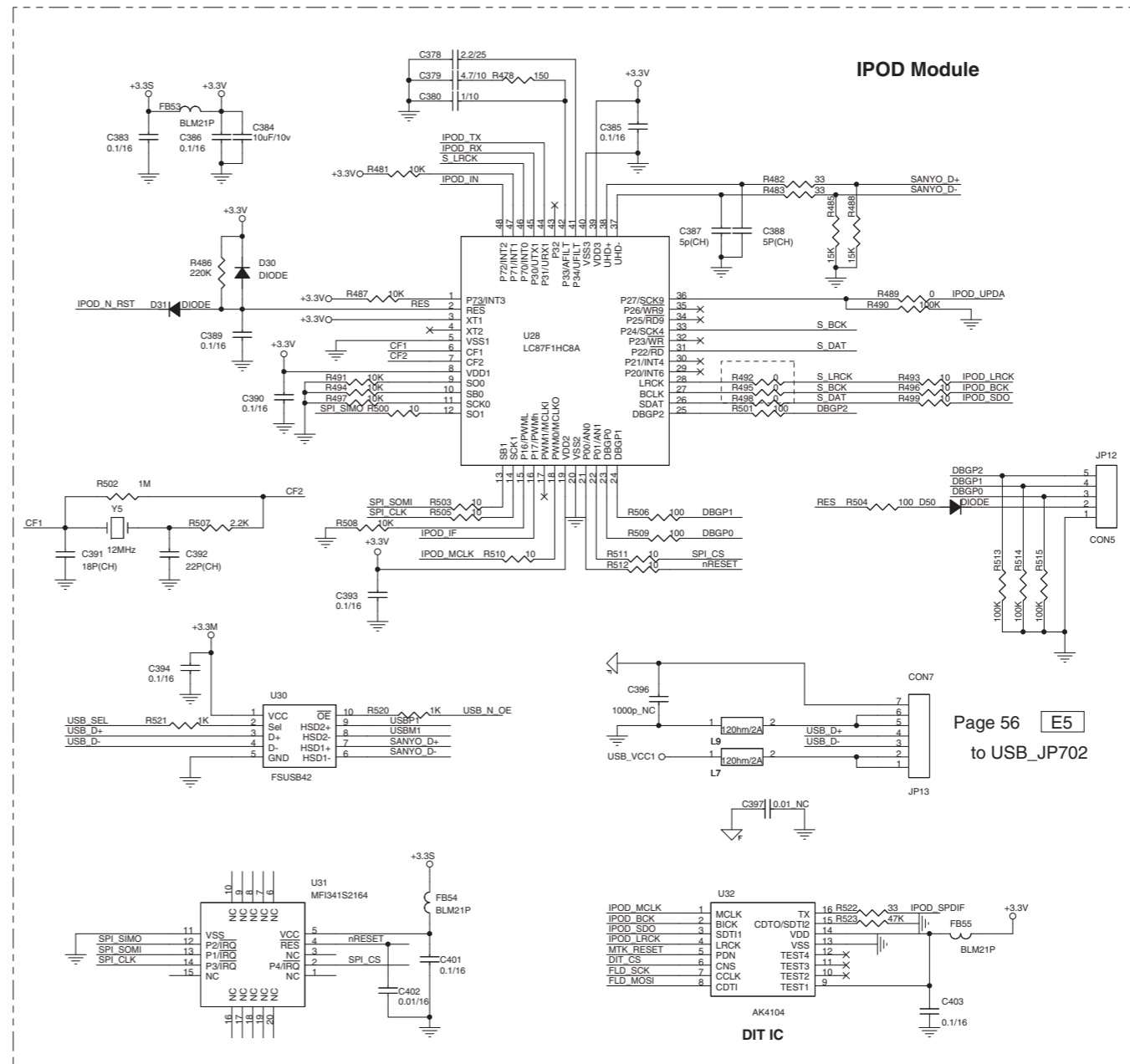

Page 56 E5 to USB_JP702

★ Components having special characteristics are marked Δ and must be replaced with parts having specifications equal to those originally installed.
★ Schematic diagram is subject to change without notice.

MAIN 14/14

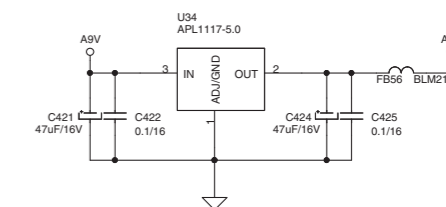
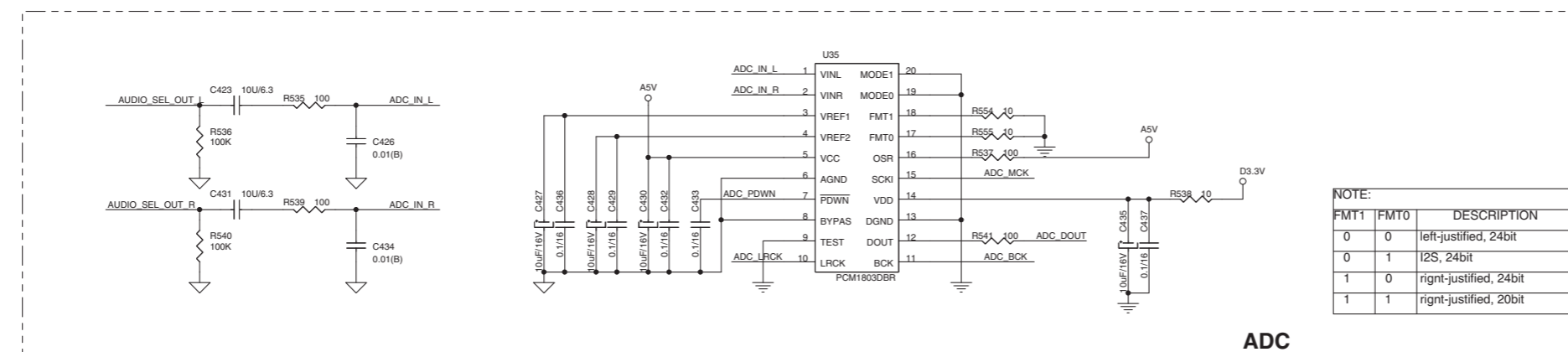
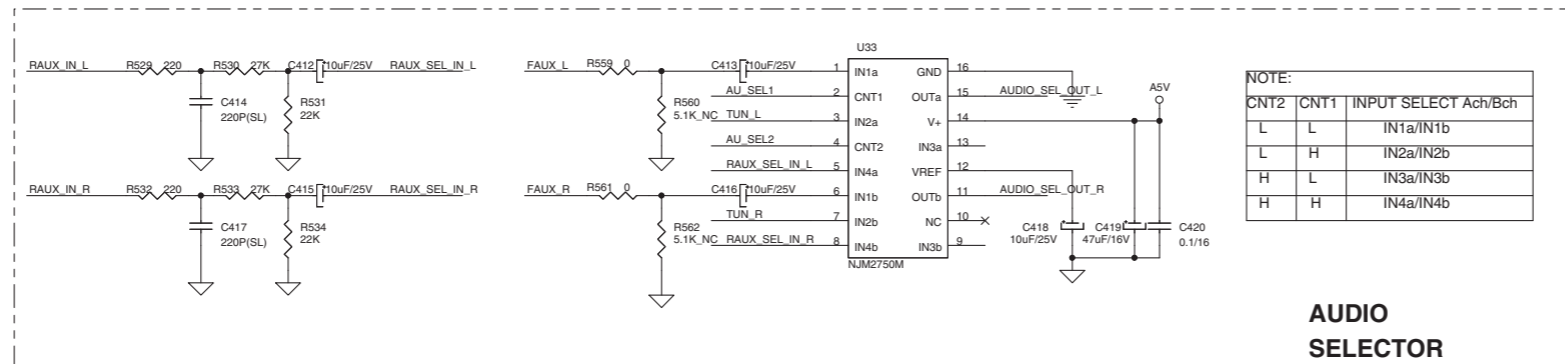
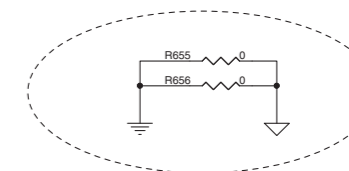
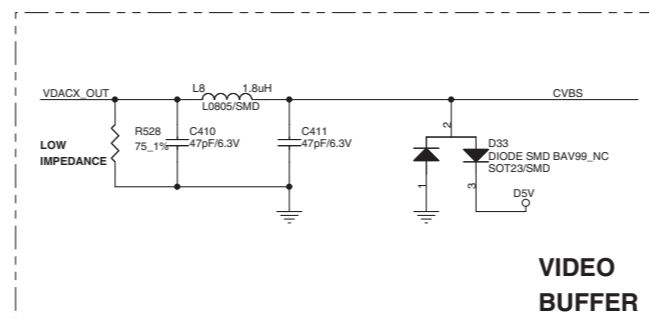
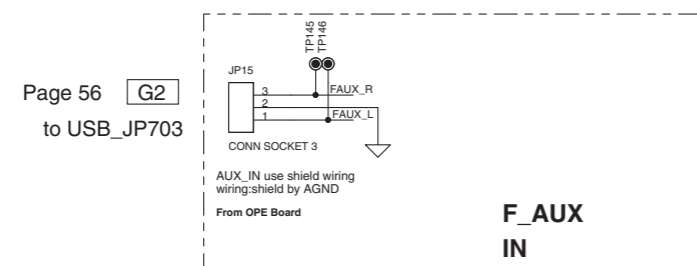
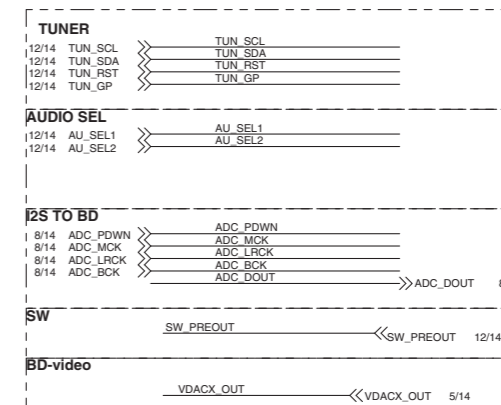
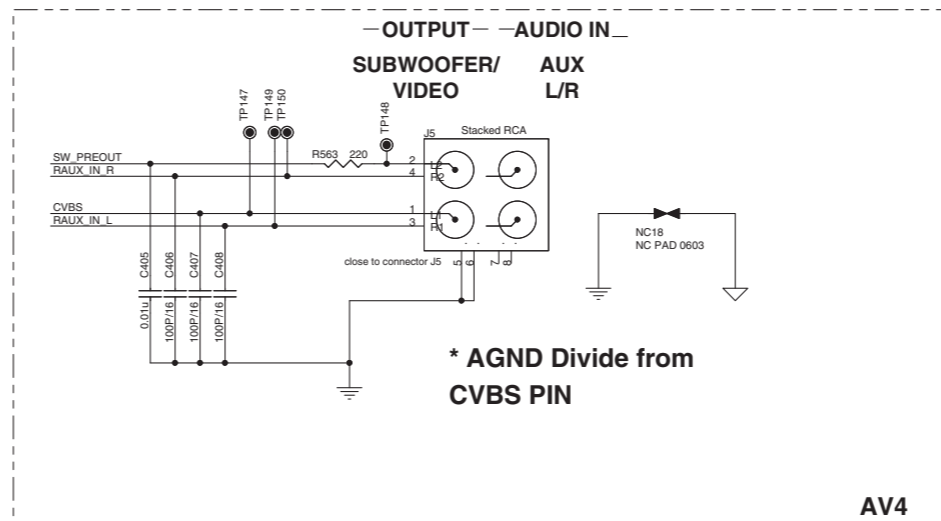
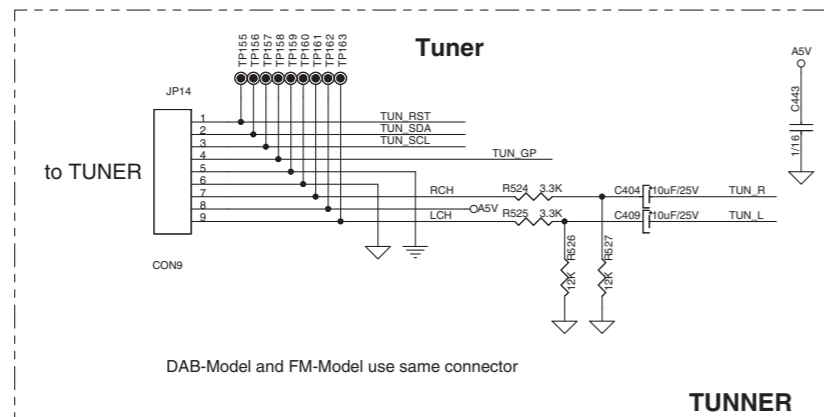

- ★ All voltages are measured with a 10MΩ/V DC electronic voltmeter.
- ★ Components having special characteristics are marked Δ and must be replaced with parts having specifications equal to those originally installed.
- ★ Schematic diagram is subject to change without notice.

OPERATION

Page 51 **B3**
to MAIN_JP8

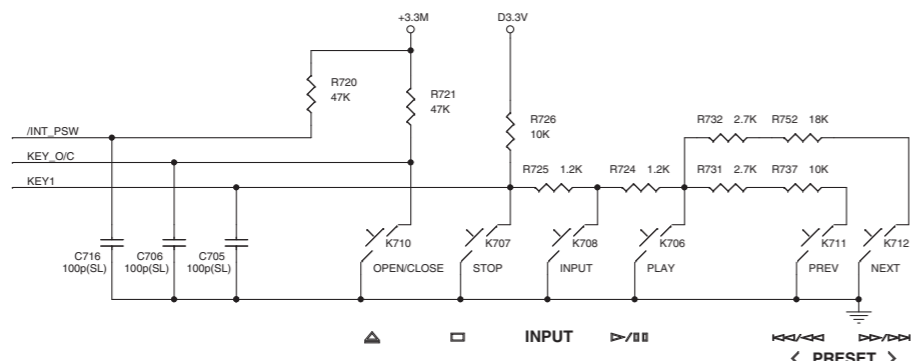
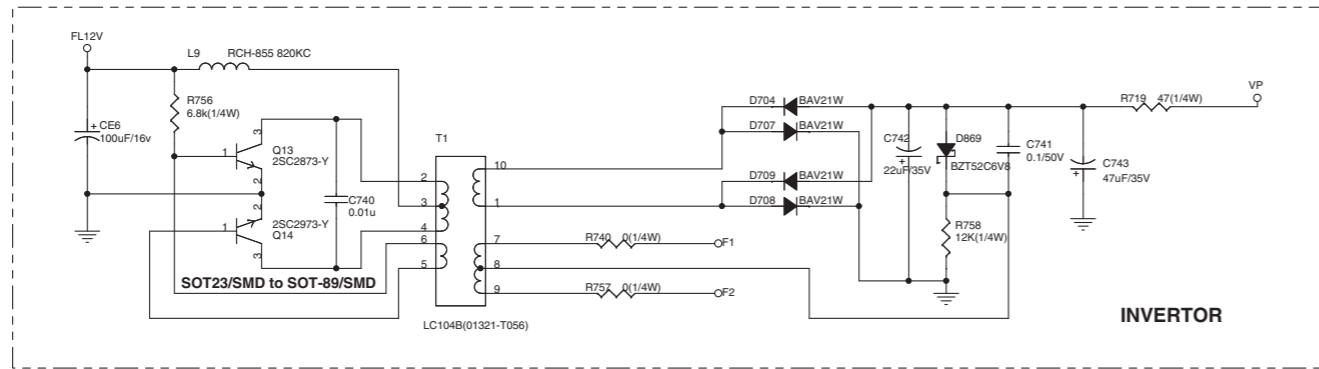
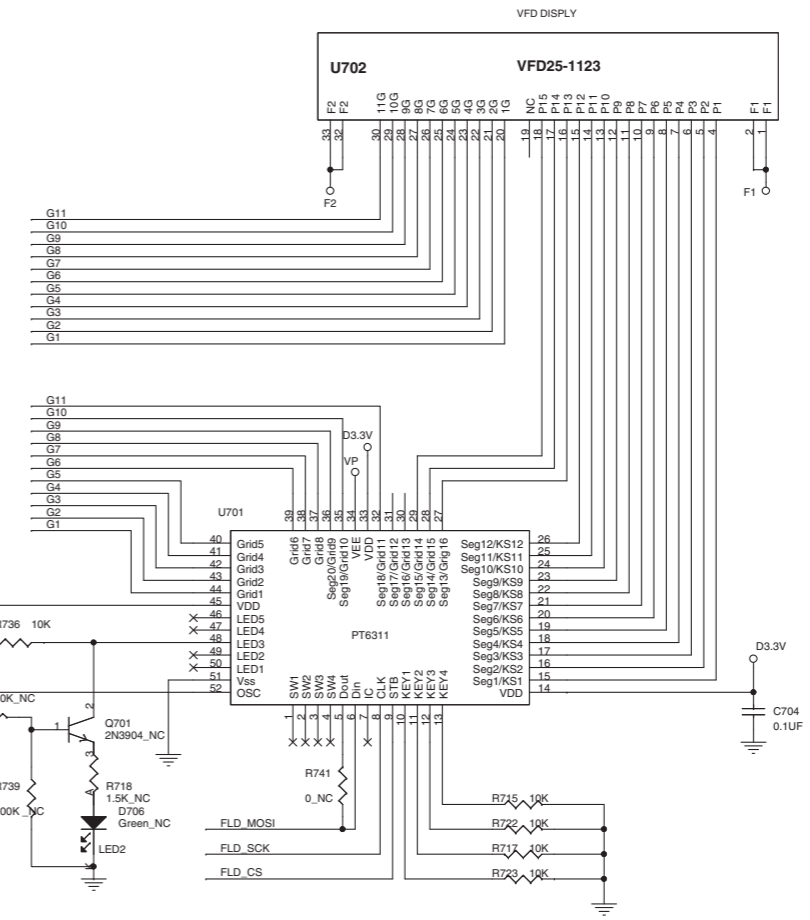
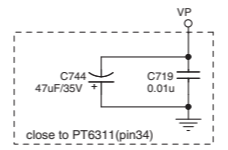
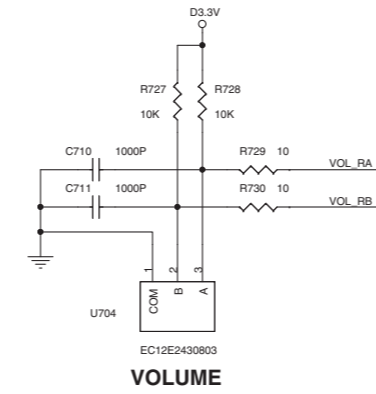
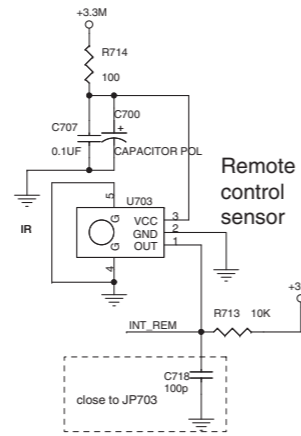
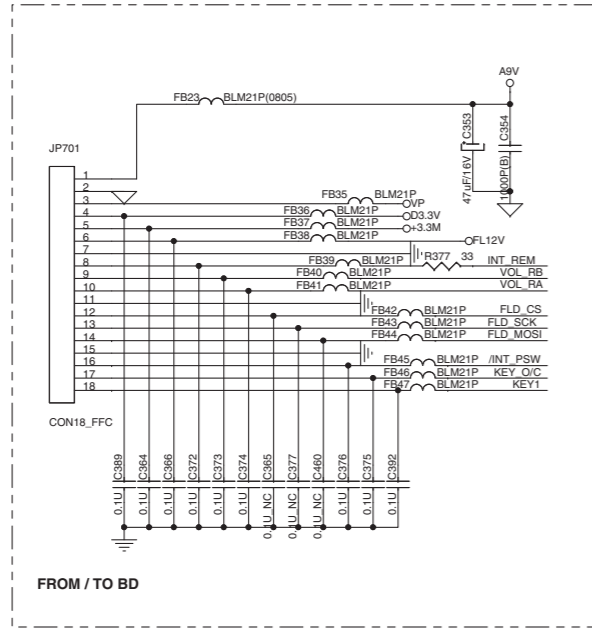

Page 56 **G2**
to USB_JP704

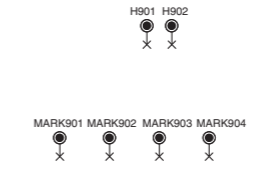
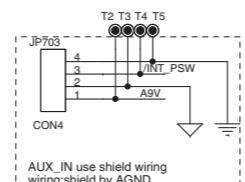

★ Components having special characteristics are marked Δ and must be replaced with parts having specifications equal to those originally installed.
★ Schematic diagram is subject to change without notice.

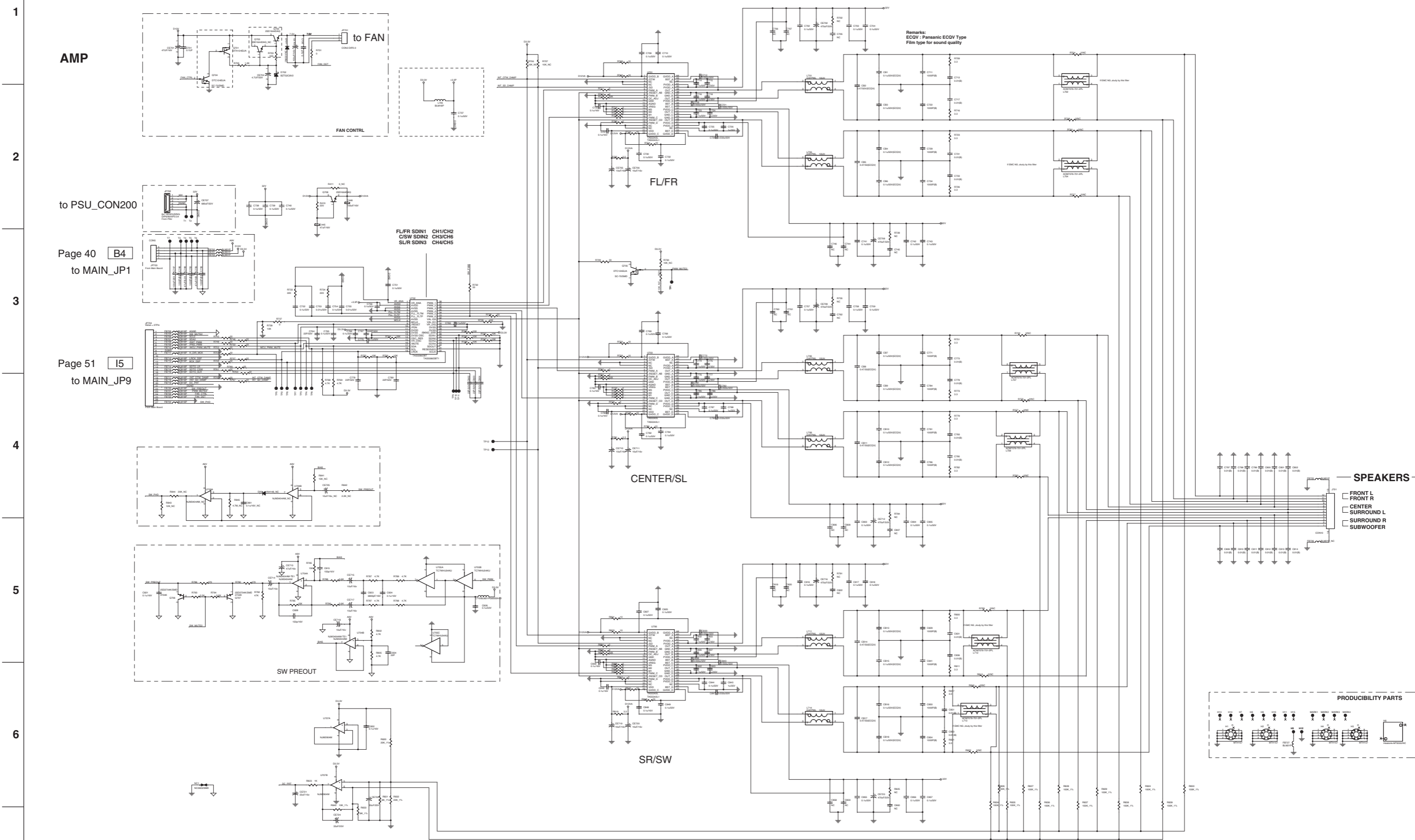

★ All voltages are measured with a 10MΩ/V DC electronic voltmeter.
 ★ Components having special characteristics are marked Δ and must be replaced with parts having specifications equal to those originally installed.
 ★ Schematic diagram is subject to change without notice.

USB

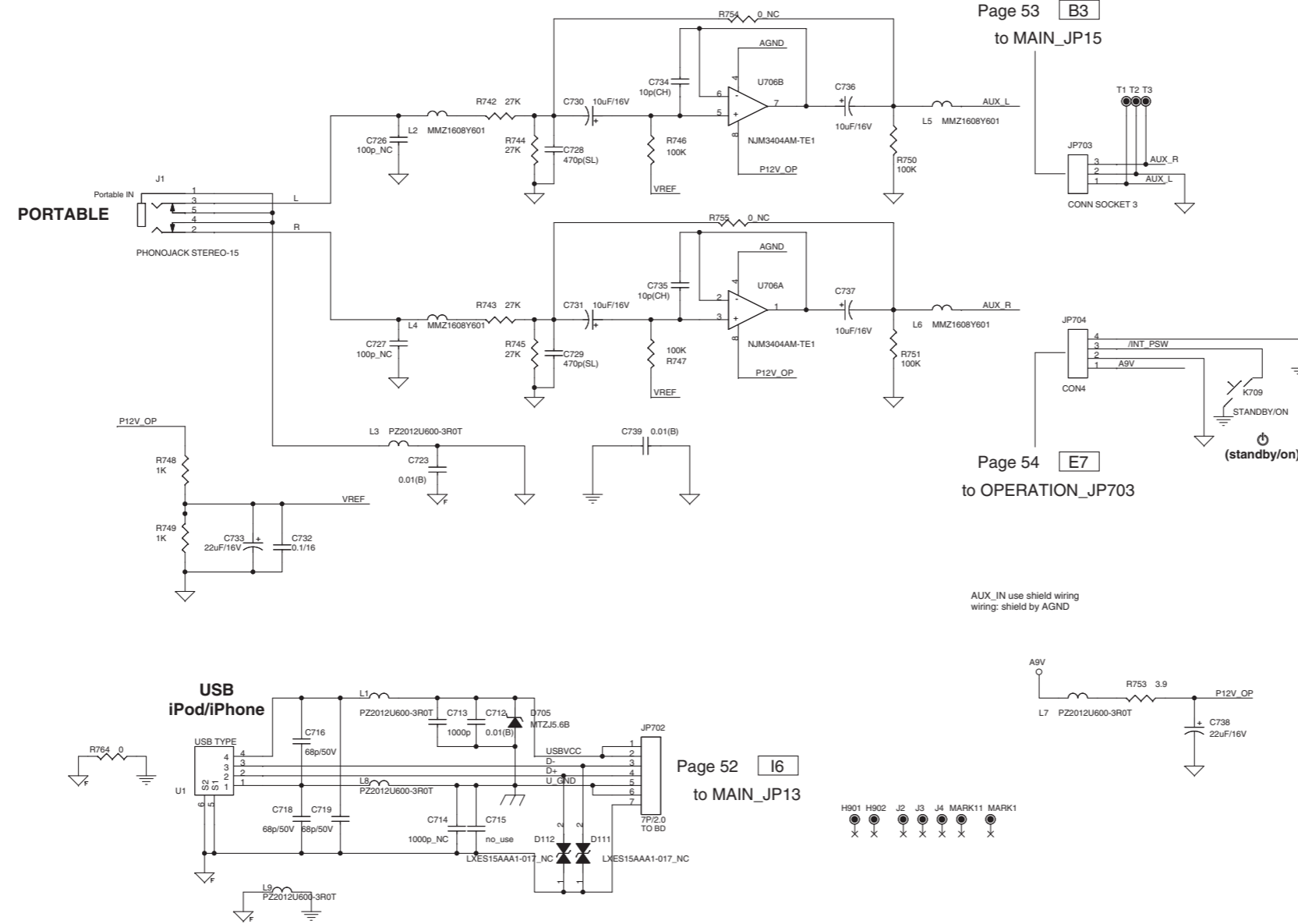

Page 53 B3
to MAIN_JP15

Page 54 E7
to OPERATION_JP703

Page 52 I6
to MAIN_JP13

AUX_IN use shield wiring
wiring: shield by AGND

★ Components having special characteristics are marked Δ and must be replaced with parts having specifications equal to those originally installed.
★ Schematic diagram is subject to change without notice.

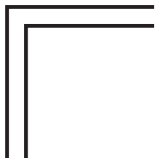

MEMO

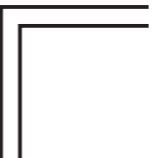
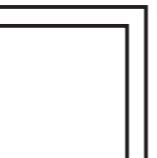

MEMO

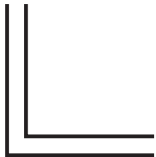
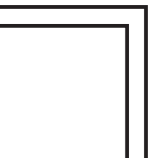

REPLACEMENT PARTS LIST

OVERALL ASSEMBLY

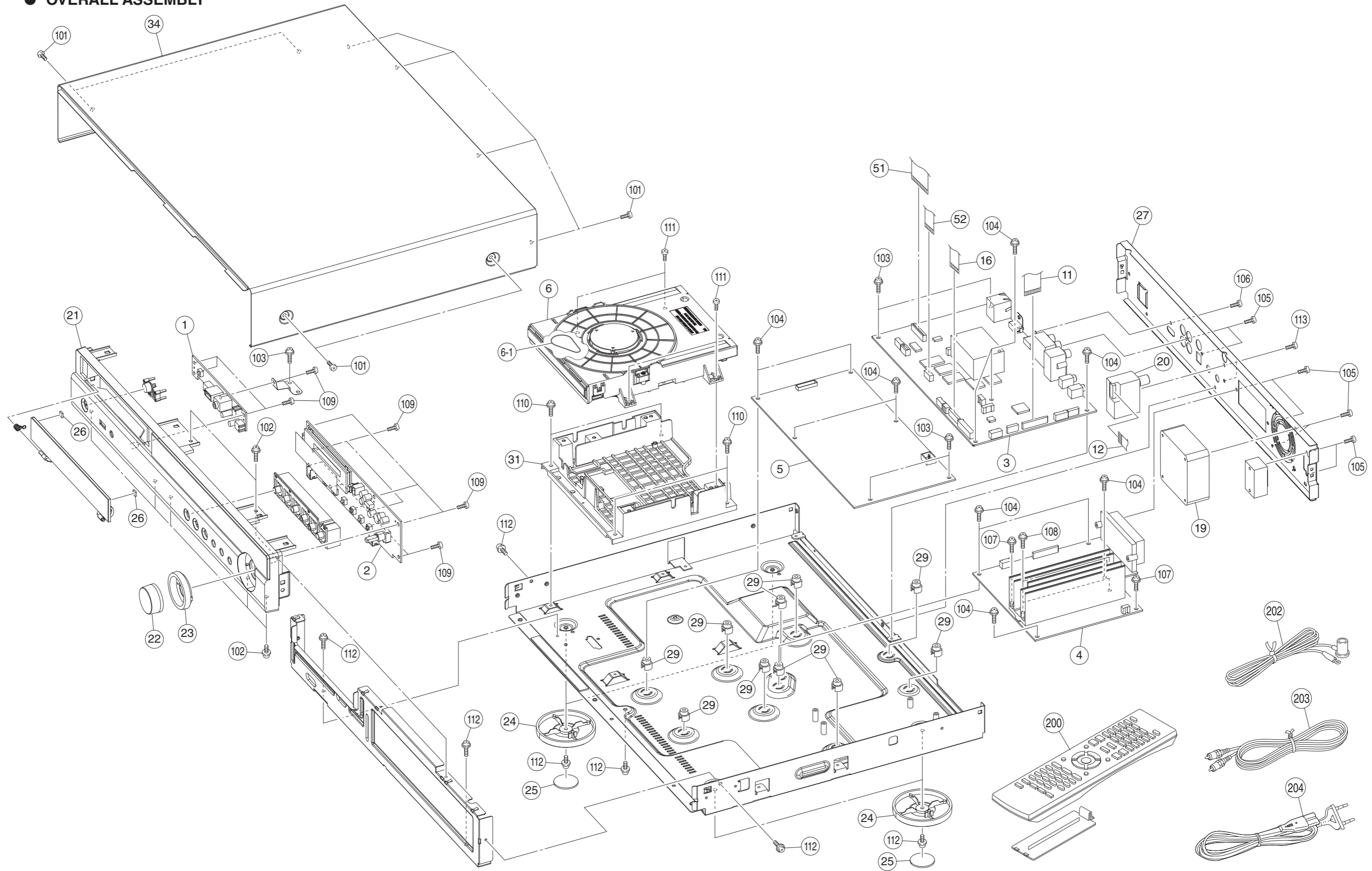

WARNING

- Components having special characteristics are marked Δ and must be replaced with parts having specifications equal to those originally installed.

Ref No.	Part No.	Description	Remarks	Markets	
* 1	ZA995500	P. C. B. ASSEMBLY	USB	JEP610U-R0	
* 2	ZA995200	P. C. B. ASSEMBLY	OPERATION	JEP610F-R0	
* 3	ZA994200	P. C. B. ASSEMBLY	MAIN	JEP610M-U-V1.0-R0	U
* 3	ZA993700	P. C. B. ASSEMBLY	MAIN	JEP610M-C-V1.0-R0	C
* 3	ZA994100	P. C. B. ASSEMBLY	MAIN	JEP610M-T-V1.0-R0	T
* 3	ZA993900	P. C. B. ASSEMBLY	MAIN	JEP610M-G-V1.0-R0	G
* 3	ZA993800	P. C. B. ASSEMBLY	MAIN	JEP610M-F-V1.0-R0	F
* 3	ZA994000	P. C. B. ASSEMBLY	MAIN	JEP610M-L-V1.0-R0	L
* 4	ZA993400	P. C. B. ASSEMBLY	AMP	JEP610A-R0	
Δ * 5	ZC004900	POWER SUPPLY UNIT	110-120V	JEPX610P-L-1-R0	UC
Δ * 5	ZC004800	POWER SUPPLY UNIT	220-240V	JEPX610P-H-1-R0	TGFL
* 6	ZA992900	BD MECHANISM UNIT	KEM-470AAA	JAY610H-R0	
6-1	WZ617700	LOADING BELT		121400000015-R0	
* 11	ZA996700	FLEXIBLE FLAT CABLE	27P 60mm P=1	JWJ27P1.0Y60L-4-R0	
* 12	ZA997000	FLEXIBLE FLAT CABLE	9P 80mm P=1.25	JWJ9P1.25T80L-4-R0	
* 16	ZA996400	FLEXIBLE FLAT CABLE	18P 260mm P=1	JWJ18P1.0Y260L-4-R0	
* 19	ZC000000	FAN		2410RL-04W-S29-CA7-R0	
20	WW891000	FM TUNER		FAEH08-W02N-R0	UCTL
20	WW891100	FM TUNER		FAEH08-E02N-R0	GF
* 21	ZC000700	FRONT PANEL ASSEMBLY		JYPX610NP-B-R0	
* 22	ZA999000	KNOB	VOLUME	JGWX610N-B-R0	
* 23	ZA995900	ESCUTCHOEN	VOLUME	JGWX610Z-B-R0	
* 24	ZC002900	FEET		JMG60x9R-HOT-R0	
* 25	ZA997200	FEET COVER		JMG25x1.5R-1-R0	
* 26	ZA999800	PAD	LID	JMG5x5x1-1-R0	
* 27	ZC001400	REAR PANEL		JGRX610R-UC-R0	UC
* 27	ZC001300	REAR PANEL		JGRX610R-T-R0	T
* 27	ZC001100	REAR PANEL		JGRX610R-G-R0	G
* 27	ZC001000	REAR PANEL		JGRX610R-F-R0	F
* 27	ZC001200	REAR PANEL		JGRX610R-L-R0	L
* 29	ZA997600	SPACER		JMN0801-R0	
* 31	ZC003300	LOADER SUPPORT		JMNX750-R0	
* 34	ZA997900	TOP COVER		JKMX610-B-R0	
* 51	ZA996800	FLEXIBLE FLAT CABLE	45P 250mm P=0.5	JWJ45P0.5T250L-3Z-4-R0	
* 52	ZA996900	FLEXIBLE FLAT CABLE	9P 200mm P=1	JWJ9P1.0T200L-3Z-4-R0	
101	WZ614600	PW HEAD S-TIGHT SCREW	3x6 MFZN2B3	PS3x6-3X-B-R0	
102	WV558200	PW HEAD S-TIGHT SCREW	3x6 MFZN2B3	PWM3x6-B-R0	
103	WV557900	PW HEAD B-TIGHT SCREW	3x5 MFZN2W3	PWB3x5-R0	
104	WV558000	PW HEAD SPECIAL SCREW	3x13 MFZN2W3	PWM3x13-R-R0	
* 105	ZA998700	PAN HEAD TAPPING SCREW	3x8 MFZN2B3	PA3x8-B-R0	
* 106	ZA999500	BIND HEAD SCREW	3x6 MFZN2B3	BM3x6-B-R0	
107	WZ616200	BIND HEAD SCREW	3x6 MFZN2W3	BWM3x6-R0	
* 108	ZA999600	BIND HEAD SCREW	3x13 MFZN2W3	BWM3x13-R0	

* New Parts

Ref No.	Part No.	Description	Remarks	Markets	
109	WV557700	PAN HEAD TAPPING SCREW	3x8 MFZN2W3	PA3x8-R0	
* 110	ZA995700	PW HEAD SCREW	3x6 MFZN2W3	PWM3x6-R-R0	
* 111	ZA999400	BIND HEAD B-TIGHT SCREW	3x10 MFZN2W3	BB3x10-R0	
112	WV558300	PW HEAD S-TIGHT SCREW	3x6 MFZN2W3	PWM3x6-R0	
* 113	ZA998900	PAN HEAD SCREW	3x6 MFZN2B3	PM3x6-B-R0	
		ACCESSORIES			
* 200	WY925300	REMOTE CONTROL	671B92-7	WY92530-R0	UCTL
* 200	WY925400	REMOTE CONTROL	671B92-6	WY92540-R0	GF
* 202	ZC003400	INDOOR FM ANTENNA	1.4m 1pc	DW-FM001-EU-R0	
* 203	ZA999900	COMPOSITE VIDEO CABLE	1.5m 1pc	JFX1101-150-1-R0	
Δ * 204	ZC004400	POWER CABLE	1.5m 1pc	JJA0014-150-6-R0	UCL
Δ * 204	ZC004200	POWER CABLE	1.5m 1pc	JJA0011-150-1-R0	T
Δ * 204	ZC004000	POWER CABLE	1.5m 1pc	JJA0008-150-1-R0	GF
		BATTERY	R03, AAA, UM-4 2pcs		

* New Parts

● OVERALL ASSEMBLY

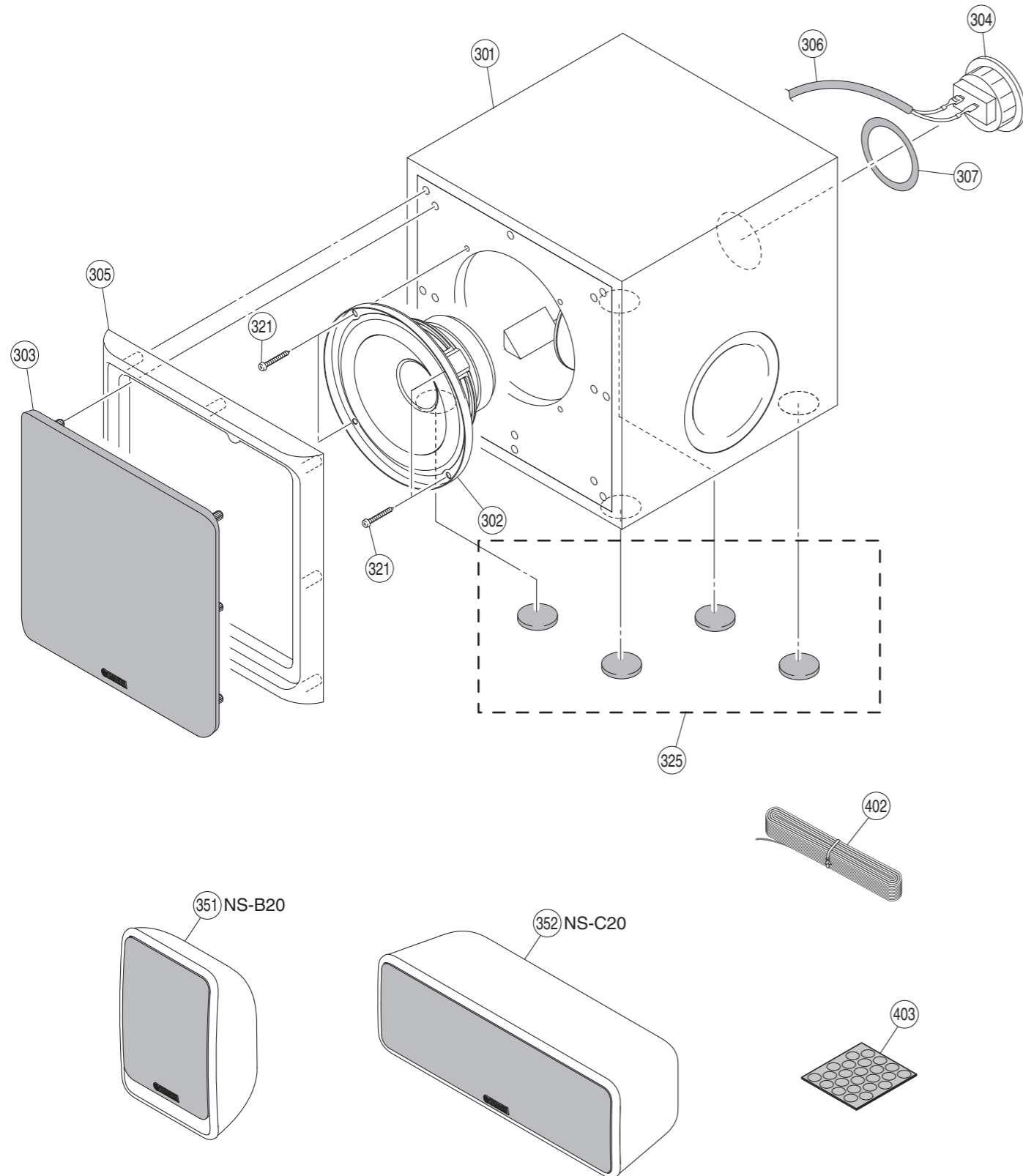

Ref No.	Part No.	Description	Remarks	Markets
301	WZ118300	CABINET ASSEMBLY		
302	YA897A00	DRIVER WOOFER	16cm 6Ω	
303	WY603300	FRONT GRILLE ASSEMBLY		
304	WY587000	TERMINAL ASSEMBLY	2P, PUSH TYPE	
305	WY263600	FRONT PANEL		
306	WW479900	PACKING	15x175	
307	WU037000	PACKING	3x550	
321	WE955200	BIND HEAD TAPPING SCREW	4x20 MFZN2B3	
325	WC731500	NONSKID PAD	D32 t2 4pcs/set	NS-SWP20
351	WY614200	SPEAKER FINAL ASSEMBLY	NS-B20	
352	WY614300	SPEAKER FINAL ASSEMBLY	NS-C20	
ACCESSORIES				
402	WR994200	SPEAKER CABLE	25m 1pc	
403	WY826100	NONSKID PAD	D8 t1 24pcs/set	NS-B20, NS-C20

* New Parts

1 ■ REMOTE CONTROL

● 671B92-7 (U, C, T, L models) / 671B92-6 (G, F models)

SCHEMATIC DIAGRAM

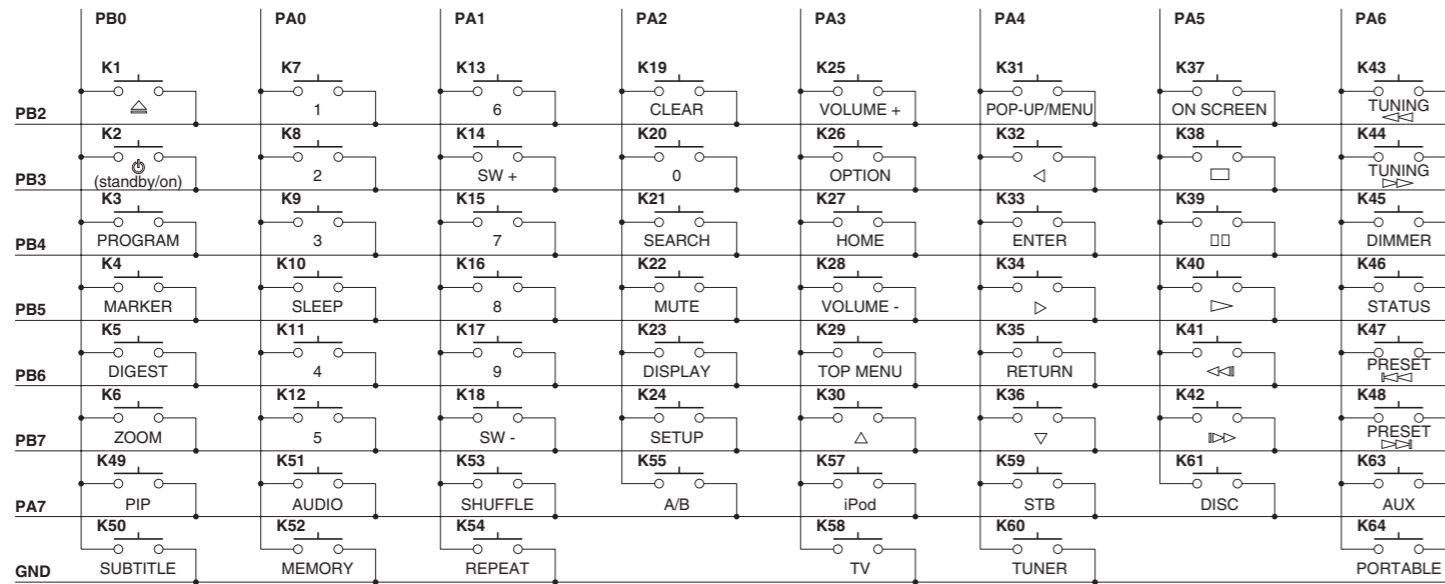
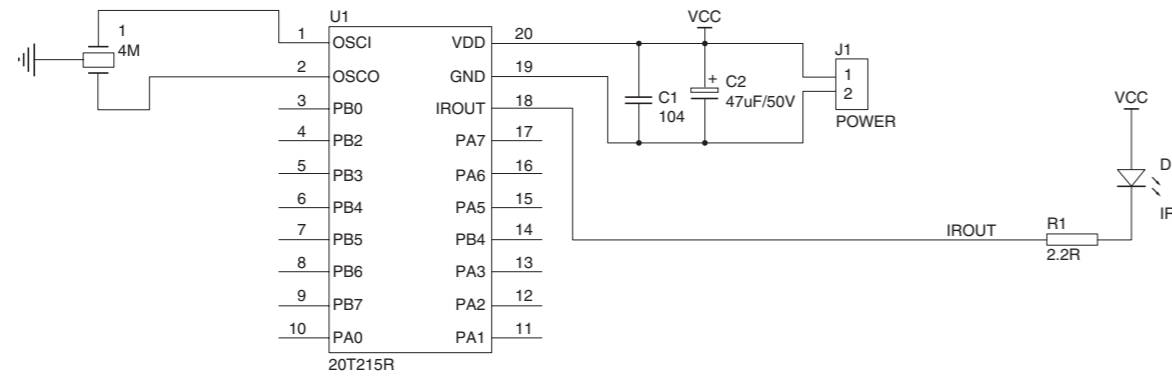

PANELS

671B92-7

(U, C, T, L models)

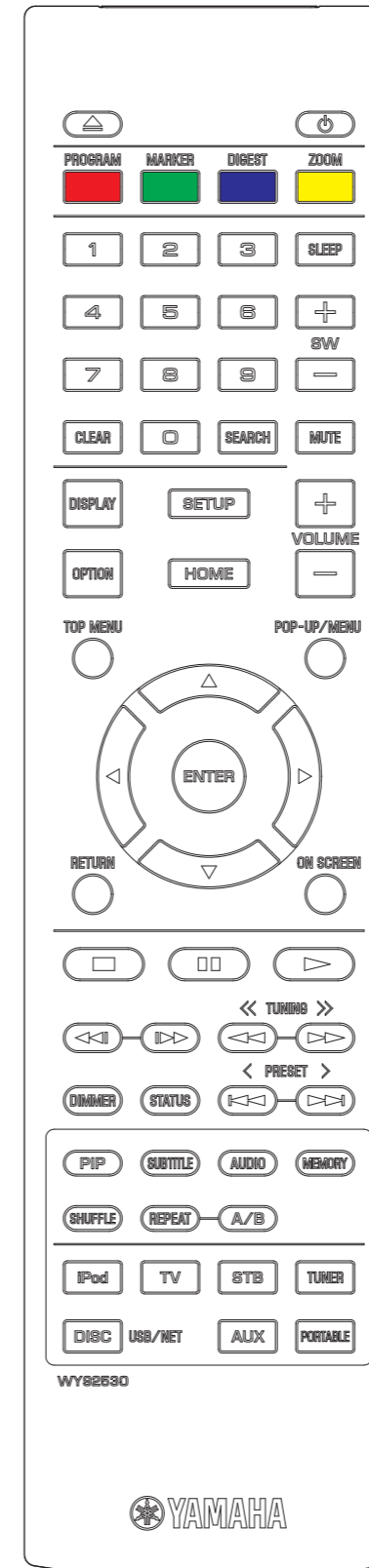

671B92-6

(G, F models)

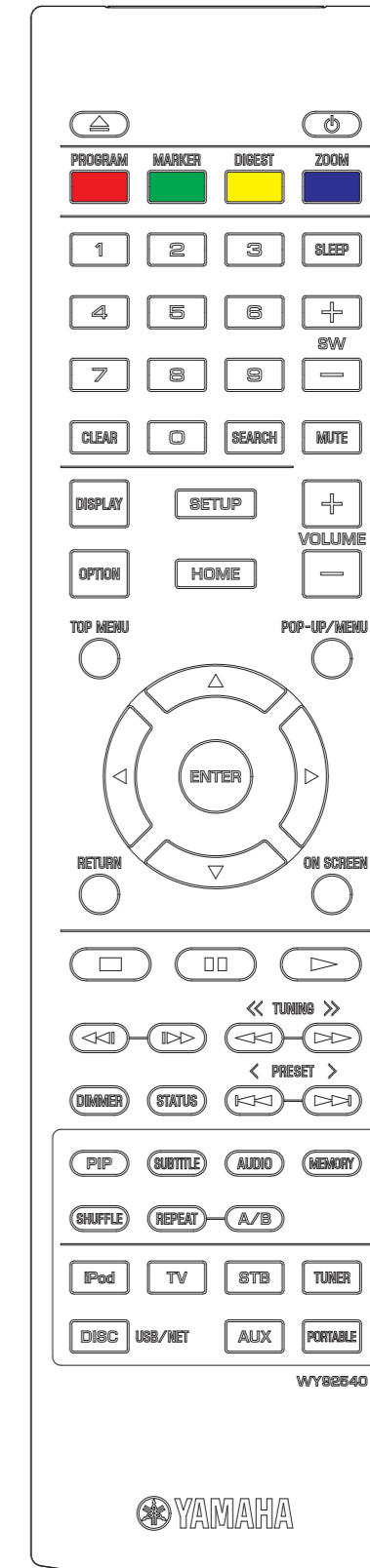

PROGRAM: Red
MARKER: Green
DIGEST: Blue
ZOOM: Yellow

PROGRAM: Red
MARKER: Green
DIGEST: Yellow
ZOOM: Blue

2
3
4
5
6
7

KEY NO. LAYOUT

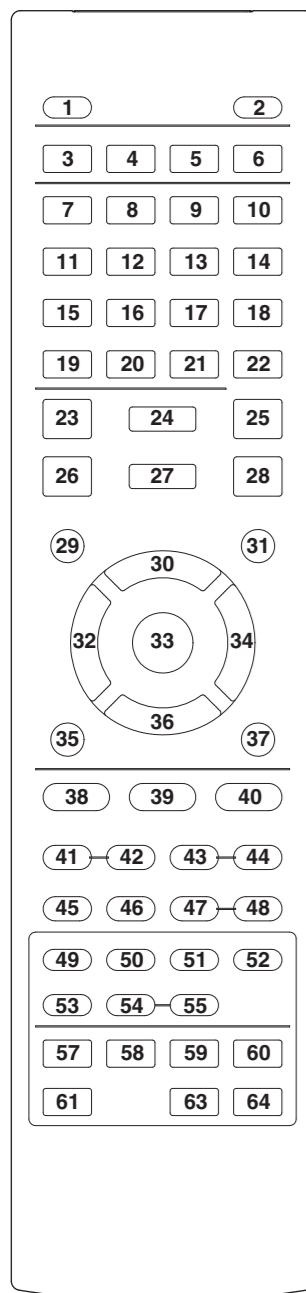

KEY NO. LAYOUT

Key No.	Key Name	custom code	data code 0	data code 1
1	▲ (Open/Close)	78	00	FF
2	⏻ (Standby/On)	78	0F	F0
3	PROGRAM (Red)	7C	E9	16
4	MARKER (Green)	7C	EA	15
5	DIGEST (Blue / U, C, T, L models)	7C	EB	14
	DIGEST (Yellow / G, F models)	7C	EC	13
6	ZOOM (Yellow / U, C, T, L models)	7C	EC	13
	ZOOM (Blue / G, F models)	7C	EB	14
7	1	7C	94	6B
8	2	7C	95	6A
9	3	7C	96	69
10	SLEEP	78	4F	B0
11	4	7C	97	68
12	5	7C	98	67
13	6	7C	99	66
14	SW +	78	4C	B3
15	7	7C	9A	65
16	8	7C	9B	64
17	9	7C	9C	63
18	SW -	78	4D	B2
19	CLEAR	7C	9F	60
20	0	7C	93	6C
21	SEARCH	7C	9E	61
22	MUTE	78	9C	63
23	DISPLAY	78	4E	B1
24	SETUP	7C	AC	53
25	VOLUME +	78	1E	E1
26	OPTION	78	2B	D4
27	HOME	7C	EF	10
28	VOLUME -	78	1F	E0
29	TOP MENU	7C	B1	4E
30	▲ (UP)	7C	B4	4B

Key No.	Key Name	custom code	data code 0	data code 1
31	POP-UP/MENU	7C	CF	30
32	◀ (Left)	7C	B5	4A
33	ENTER	7C	B8	47
34	▶ (Right)	7C	B6	49
35	RETURN	7C	B7	48
36	▼ (Down)	7C	B3	4C
37	ON SCREEN	7C	A6	59
38	■ (Stop)	7C	85	7A
39	■ (Pause)	7C	83	7C
40	▶ (Play)	7C	82	7D
41	◀◀ (INS Replay)	7C	C3	3C
42	▶▶ (INS Search)	7C	C2	3D
43	◀◀ (Search -)	7C	86	79
44	▶▶ (Search +)	7C	87	78
45	DIMMER	78	BA	45
46	STATUS	7C	A8	57
47	⏮ (Skip -)	7C	B9	46
48	⏭ (Skip +)	7C	BA	45
49	PIP	7C	ED	12
50	SUBTITLE	7C	AB	54
51	AUDIO	7C	AD	52
52	MEMORY	78	B2	4D
53	SHUFFLE	7C	A1	5E
54	REPEAT	7C	A3	5C
55	A/B	7C	A4	5B
57	iPod	78	D0	2F
58	TV (HDMI_ARC)	78	DF	20
59	STB	78	41	BE
60	TUNER	78	4B	B4
61	DISC USB/NET	78	4A	B5
63	AUX	78	49	B6
64	PORTABLE	78	DE	21

Extended IR code

Key No.	Function	custom code	data code 0	data code 1
Ex1	POWER ON	78	7E	81
Ex2	POWER OFF	78	7F	80
Ex3	REPEAT OFF	7C	F3	0C
Ex4	MARKER	7C	D8	27
Ex5	ZOOM	7C	D7	28
Ex6	DIGEST	7C	E2	1D
Ex7	PROGRAM	7C	A0	5F
Ex8	Video Reset	7C	C1	3E
Ex10	Information Display	7C	C5	3A
Ex11	Change Player Setting	7C	CE	31
Ex12	Display Error Rate	7C	C4	3B
	Mute On	7E	A2	5D
	Mute Off	7E	A3	5C
	SLEEP OFF	7E	B3	4C
	SLEEP 120	7E	B4	4B
	SLEEP 90	7E	B5	4A
	SLEEP 60	7E	B6	49
	SLEEP 30	7E	B7	48

■ SOFTWARE UPGRADE

Some of the newly released BD discs cannot be played back unless you upgrade this unit software to the latest version. We recommend upgrading the software of this unit with software upgrade so that the unit is operated based on the latest software.

To check for the availability of a software upgrade, visit

<http://download.yamaha.com/>

Note

Do not remove the USB memory device, set this unit to standby mode or unplug the power cable/LAN cable while the software upgrade is being performed.

Upgrading the software

- 1 Prepare for the software upgrade.
When you upgrade the software from [Network]:
Confirm that this unit is connected to the network.
When you upgrade the software from [USB Storage]:
 - ① Save the upgrade file package to the appropriate folder on the USB memory device. For more details, refer to the procedure document attached with the upgrade file package.
 - ② Connect the USB memory device.
If the software upgrade is started automatically when the USB memory is connected, skip step 2 below.
- 2 Select the upgrade method and start upgrade from SETUP menu.
 - ① Press **SETUP** to display SETUP menu screen.
 - ② Select [General Setting] → [System] → [Upgrade].
 - ③ Select the item which contains the upgrade file package from [USB Storage]/[Network].

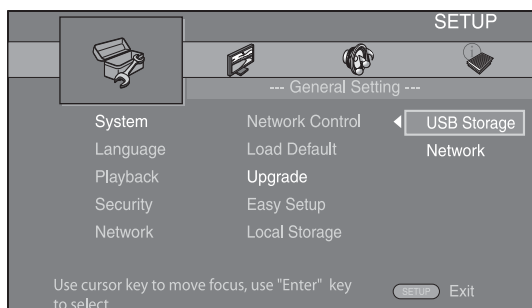

- 3 Start upgrade by following the on-screen messages.