

STEREO CONTROL AMPLIFIER

C-50

SERVICE MANUAL

FRONT PANEL

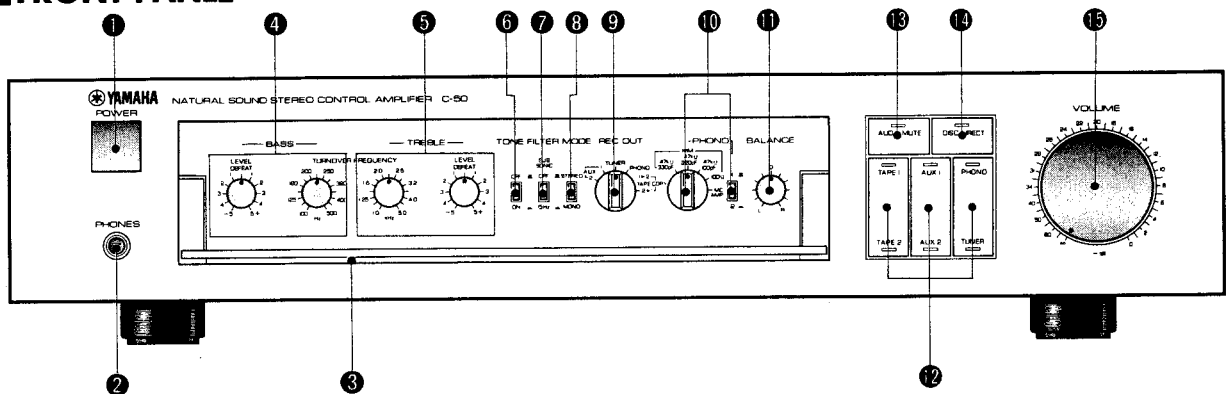

- | | |
|----------------------------|-----------------------|
| 1 POWER Switch | 9 REC OUT Switch |
| 2 Headphones Jack (PHONES) | 10 PHONO Switch |
| 3 Subcontrols panel cover | 11 BALANCE Control |
| 4 BASS Control | 12 Input Selector |
| 5 TREBLE Control | 13 AUDIO MUTE Switch |
| 6 TONE DEFEAT Switch | 14 DISC DIRECT Switch |
| 7 FILTER Switch | 15 VOLUME Control |
| 8 MODE Switch | |

CONTENTS

| | |
|---|---|
| REAR PANEL | 1 |
| NAME OF THE PARTS | 2 |
| SPECIFICATIONS | 2 |
| DISASSEMBLY INSTRUCTIONS | 3 |
| BLOCK DIAGRAM | 4 |
| GENERAL ADJUSTMENT | 5 |
| Adjusting points | 5 |
| PRINTED CIRCUIT BOARD PATTERN-SIDE LAYOUT | 6 |
| PRINTED CIRCUIT BOARD PARTS-SIDE COMPONENTS LAYOUT/WIRING | 7 |
| COMPLETE CIRCUIT DIAGRAM | 8 |

004460

SINCE 1887



YAMAHA

NIPPON GAKKI CO., LTD. HAMAMATSU, JAPAN

'82.4.2.65K



Printed in Japan.

REAR PANEL

U.S.A. and Canadian Models

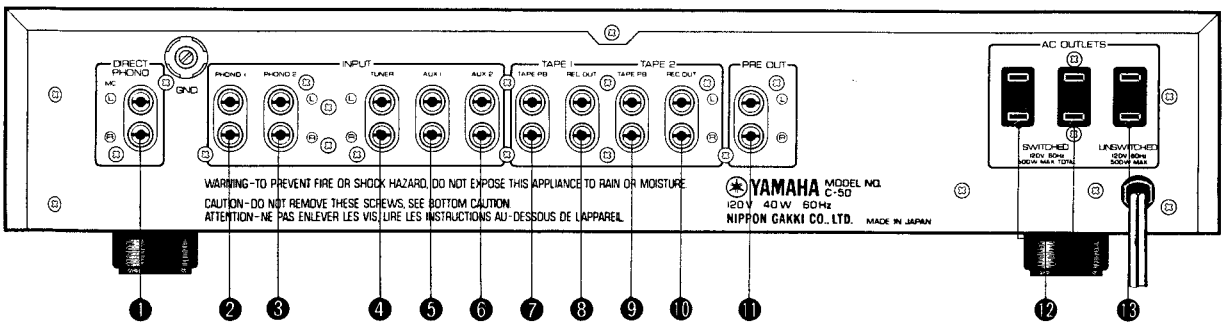

- | | |
|-------------------------------|----------------------------|
| 1 DIRECT PHONO MC input jacks | 8 TAPE 1/REC OUT jacks |
| 2 PHONO input jacks 1 | 9 TAPE 2/TAPE PB jacks |
| 3 PHONO input jacks 2 | 10 TAPE 2/REC OUT jacks |
| 4 TUNER input jacks | 11 PRE OUT jacks |
| 5 AUX input jacks 1 | 12 AC OUTLETS (switched) |
| 6 AUX input jacks 2 | 13 AC OUTLETS (unswitched) |
| 7 TAPE 1/TAPE PB jacks | |

Australian and British Models

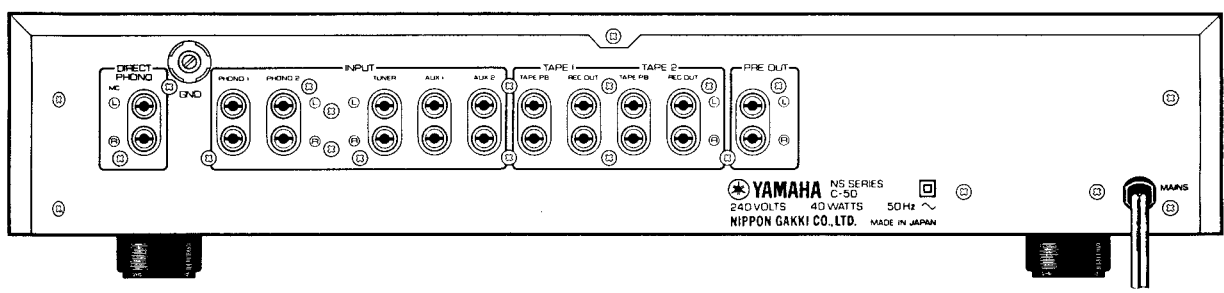

European Model

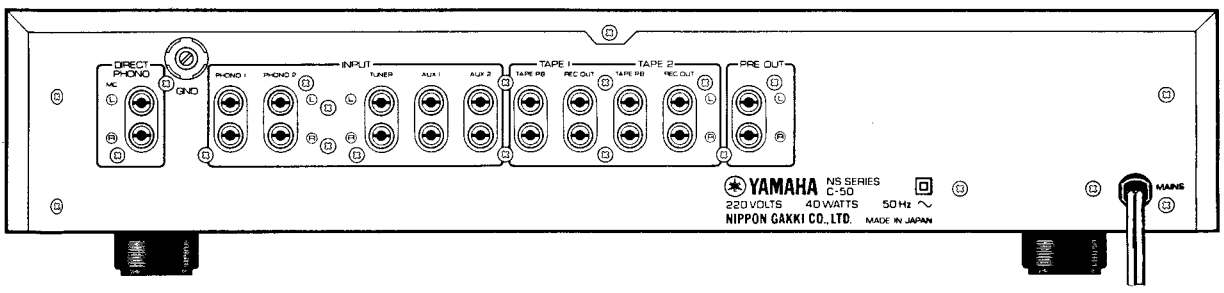

General Model

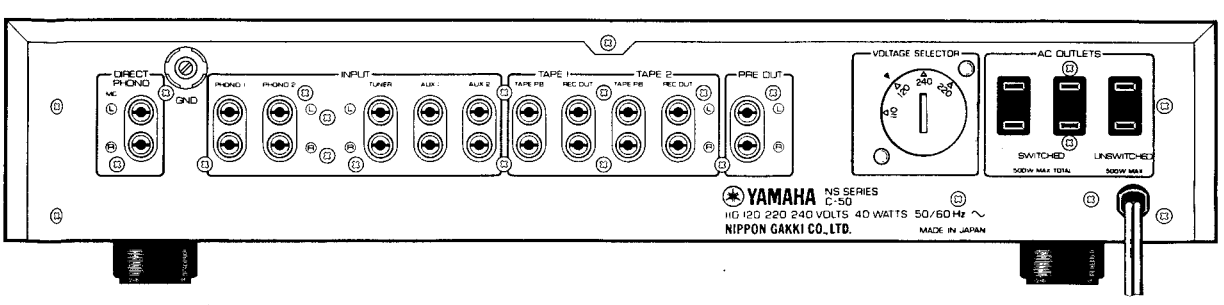

NAME OF THE PARTS

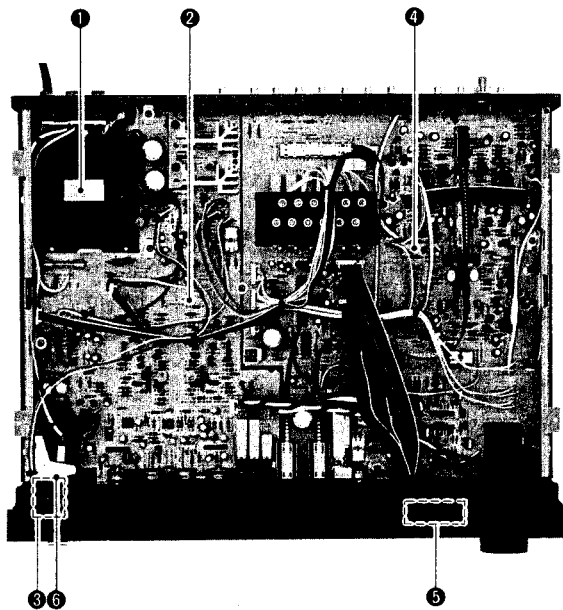

- ① Power transformer
- ② Tone control circuit board (1)
- ③ Tone control circuit board (2)
- ④ Equalizer circuit board (1)
- ⑤ Button unit
- ⑥ Power switch

SPECIFICATIONS

Input Sensitivity/Impedance

| | |
|------------------|----------------------|
| Phono MC | 100 μ V/100 ohms |
| Phono MM | 2.5 mV/100 ohms |
| 100 pF | 2.5 mV/47 kohms |
| 220 pF | 2.5 mV/47 kohms |
| 330 pF | 2.5 mV/47 kohms |
| Aux, Tape, Tuner | 150 mV/47 kohms |

Input Sensitivity (New IHF)

| | |
|------------------|------------|
| Phono MC | 33 μ V |
| Phono MM | 0.83 mV |
| Aux, Tape, Tuner | 50 mV |

Maximum Input Level (1 kHz, 0.01% THD/New IHF)

| | |
|----------|---------------|
| Phono MC | 8.5 mV/8 mV |
| Phono MM | 220 mV/220 mV |

Output Level/Impedance

| | |
|---------|-----------------|
| REC Out | 150 mV/470 ohms |
| Pre Out | 1.5 V/47 ohms |

Maximum Output Level (20 Hz to 20 kHz, 0.1% THD)

| | |
|---------|------|
| Pre Out | 10 V |
|---------|------|

Headphone Maximum Output Level/Impedance

| | |
|--|----------------|
| (1 kHz, 0.01% THD, Output impedance 68 ohms) | |
| | 0.45 V/8 ohms |
| | 4.0 V/100 ohms |

Frequency Response

| | |
|-----------------------------|-----------------------------|
| Aux, Tape, Tuner to Pre Out | +0, -0.5 dB (DC to 100 kHz) |
|-----------------------------|-----------------------------|

RIAA Deviation

| | |
|--------------|---------------------------------|
| Phono MC, MM | \pm 0.2 dB (20 Hz to 20 kHz) |
| | \pm 0.5 dB (10 Hz to 100 kHz) |

Total Harmonic Distortion (20 Hz to 20 kHz)

| | |
|-----------------------------|--------------------------------------|
| Phono MC to Rec Out | 0.002% (3 V output) |
| Phono MM to Rec Out | 0.001% (3 V output) |
| Aux, Tape, Tuner to Pre Out | 0.001% (5 V output, tone switch OFF) |

Intermodulation (Tone switch OFF)

| | |
|------------------|---------------------|
| Aux, Tape, Tuner | 0.002% (5 V output) |
|------------------|---------------------|

Signal to Noise Ratio (IHF-A-Network)

| | |
|------------------|------------------------------------|
| Phono MC | 90 dB (500 μ V, Input shorted) |
| Phono MM | 93 dB (5 mV, Input shorted) |
| Aux, Tape, Tuner | 105 dB (Tone switch OFF) |

Signal to Noise Ratio (New IHF)

| | |
|------------------|-------|
| Phono MC | 80 dB |
| Phono MM | 81 dB |
| Aux, Tape, Tuner | 96 dB |

Residual Noise

| | |
|-----------------|-------------|
| (IHF-A-Network) | 2.5 μ V |
|-----------------|-------------|

Channel Separatio

| | |
|-----------------|-----------------------|
| Phono MM 40 Hz | 85 dB (Input shorted) |
| 1 kHz | 80 dB (Input shorted) |
| 10 kHz | 68 dB (Input shorted) |
| Aux, Tape 40 Hz | 85 dB (5.1 kohms) |
| 1 kHz | 70 dB (5.1 kohms) |
| 10 kHz | 53 dB (5.1 kohms) |

Tone Control Characteristics

| | |
|---------------------------|---------------|
| Bass (boost/cut) | \pm 10 dB |
| Bass Turnover Frequency | 100 to 500 Hz |
| Treble (boost/cut) | \pm 10 dB |
| Treble Turnover Frequency | 1 to 5 kHz |

Subsonic Filter

| | |
|-----------------|-------------------|
| Characteristics | 15 Hz, -12 dB/oct |
|-----------------|-------------------|

Audio Muting

| | |
|--|--------|
| | -20 dB |
|--|--------|

General

| | |
|--------------|------------------------------------|
| Power Supply | AC 120V, 60Hz (U, C) |
| | AC 220V, 50Hz (G) |
| | AC 240V, 50Hz (A, B) |
| | AC 110/120/220/240 V, 50/60 Hz (R) |

Power Consumption

| | |
|------------|------------------------------|
| | 40 W |
| AC Outlets | 500W max total (Switched x2) |
| | 500W max (Unswitched) |

Dimensions (W x H x D)

| | |
|--|----------------------------|
| | 435 x 96.5 x 369 mm |
| | (17-1/8 x 3-3/4 x 14-1/2") |

Weight

| | |
|--|-------------------|
| | 6.8 kg (15.0 lbs) |
|--|-------------------|

Specifications subject to change without notice.

- U: U.S.A Model
- C: Canadian Model
- R: General Model
- A: Australian Model
- B: British Model
- G: European Model

DISASSEMBLY INSTRUCTIONS

1. Removal of Top and Bottom Covers

- Remove screws ① ~ ⑤ shown in photo 1, and remove the top cover by pulling it in the direction indicated by the arrow.
- Remove screws ⑥ ~ ⑬ shown in photo 1 and remove the bottom cover. (Note that screw ⑪ is different from the other screws ⑥ ~ ⑬. When fastening the screws again, do not apply too much force, as this could deform the sub-chassis.)

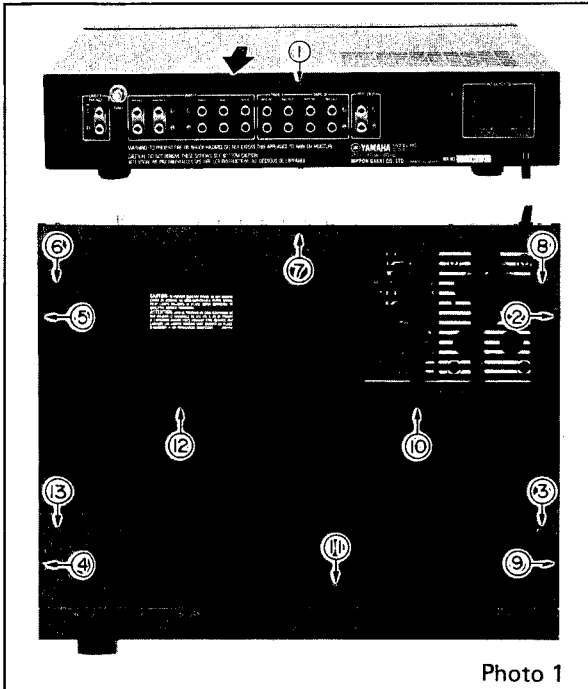

Photo 1

2. Removal of Front Panel

- Remove the top cover as described in step 1.
- Remove all knobs inside the subcontrol panel enclosure.
- Remove all wire connectors from the control button unit.
- When screws ① ~ ⑧ shown in photo 2 are re-

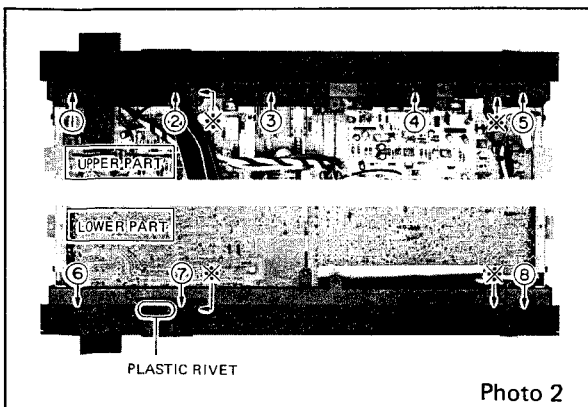

Photo 2

moved, the front panel can be removed with the subcontrol panel enclosure attached to it.

Note: The four screws marked with * in photo 2 are for the dismantling of the subcontrol panel enclosure. They should be removed only if the front panel or the subcontrol panel enclosure are to be replaced.

3. Removal of Control Button Unit

- Remove front panel as described in steps 1 and 2.
 - Pull out the two plastic rivets shown in photo 2 with a wire cutter or the like, as shown in fig. 1. The wire stay can now be removed.
 - When the front panel is lightly pushed from the outside, it comes off.
- * Be careful not to apply too much force, as this can damage the button unit.

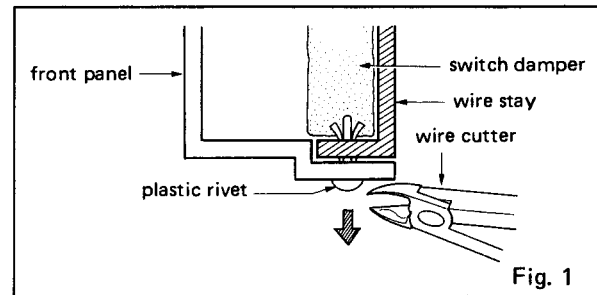
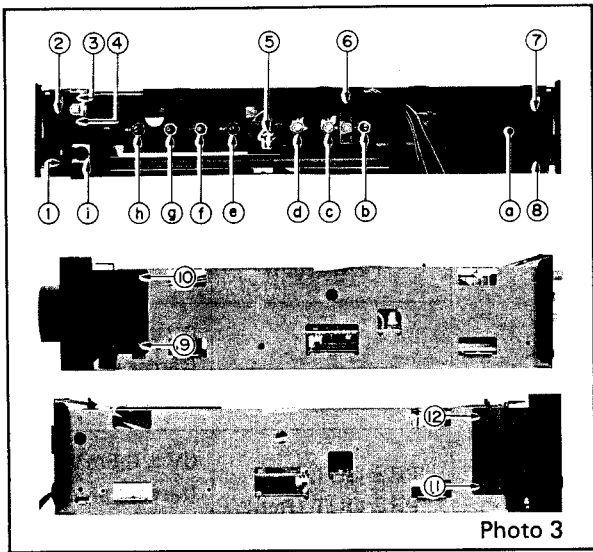

Fig. 1

4. Removal of Sub-chassis

- Perform steps 1. ~ 3.
- Loosen the volume control knob a shown in photo 3 with a hex wrench, remove it and the fastening nut from the shaft.
- Remove nuts ② ~ ④ shown in photo 3 and remove stopper ①.
- Remove screws ① ~ ⑫ shown in photo 3. The sub-chassis can now be removed.

*Adjustments or part replacements can now be performed.



■ BLOCK DIAGRAM

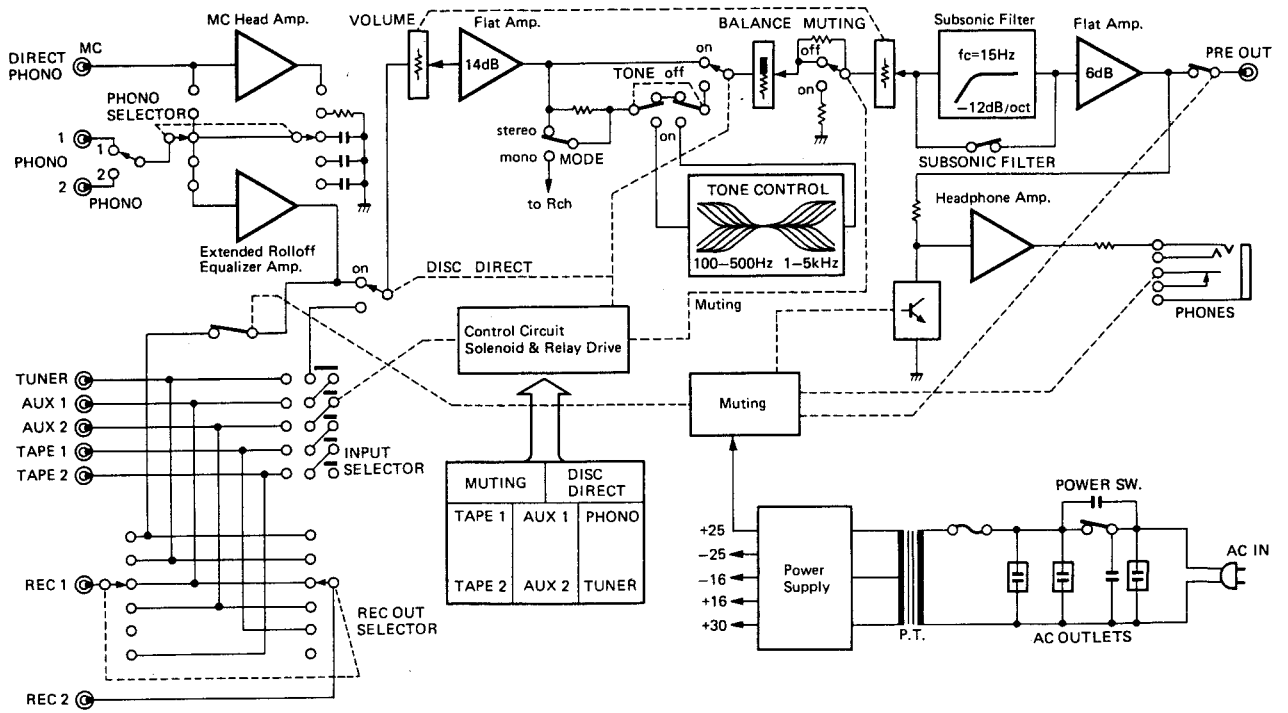

GENERAL ADJUSTMENTS

Before performing adjustments, turn on the power and wait 3 to 4 minutes, until amplifier operation has become stable.

| Step | Adjustment Item | Adjustment Point | Instrument | Output Terminals Test Point | Rating |
|------|---|----------------------------|--------------|--------------------------------|--|
| 1 | EQ AMP midpoint adjustment (equalizer circuit board (1)) | VR101 (Lch) VR102 (Rch) | DC voltmeter | TP1-E (Lch) TP2-E (Rch) | $0 \pm 100\text{mV}$ |
| 2 | FLAT AMP midpoint adjustment (equalizer circuit board (2)) | VR103 (Lch) VR104 (Rch) | | FL-E FR-E | $0\text{V} \pm 0.5\text{mV}$ (target value) $0 \pm 0.2\text{mV}$ |
| 3 | FLAT AMP midpoint adjustment (tone control circuit board (1)) | VR405 (Lch) VR406 (Rch) | | PRE OUT (Lch) PRE OUT (Rch) | $0\text{V} \pm 0.5\text{mV}$ (target value) $0 \pm 0.2\text{mV}$ |

Adjusting points

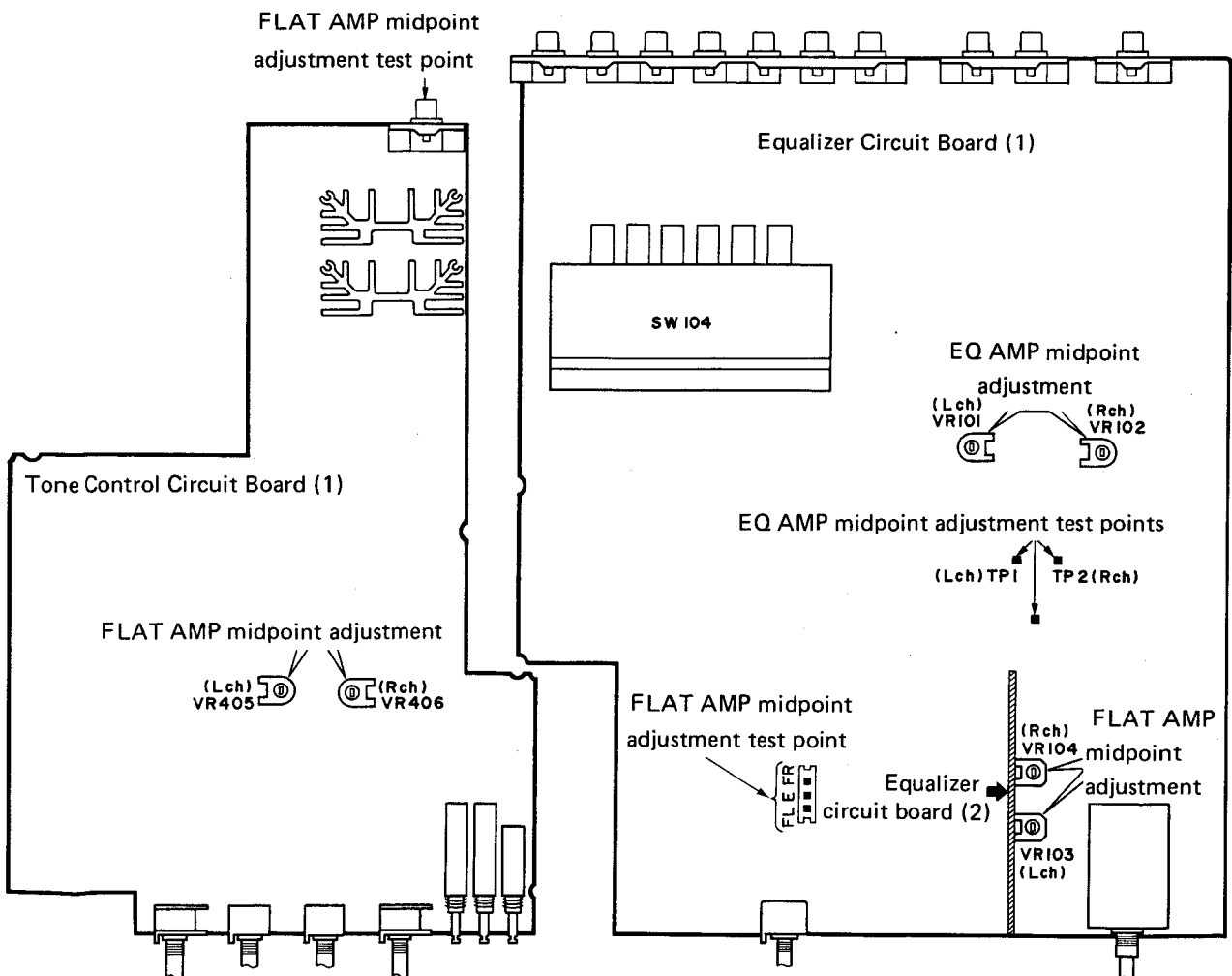

PRINTED CIRCUIT BOARD PATTERN-SIDE LAYOUT

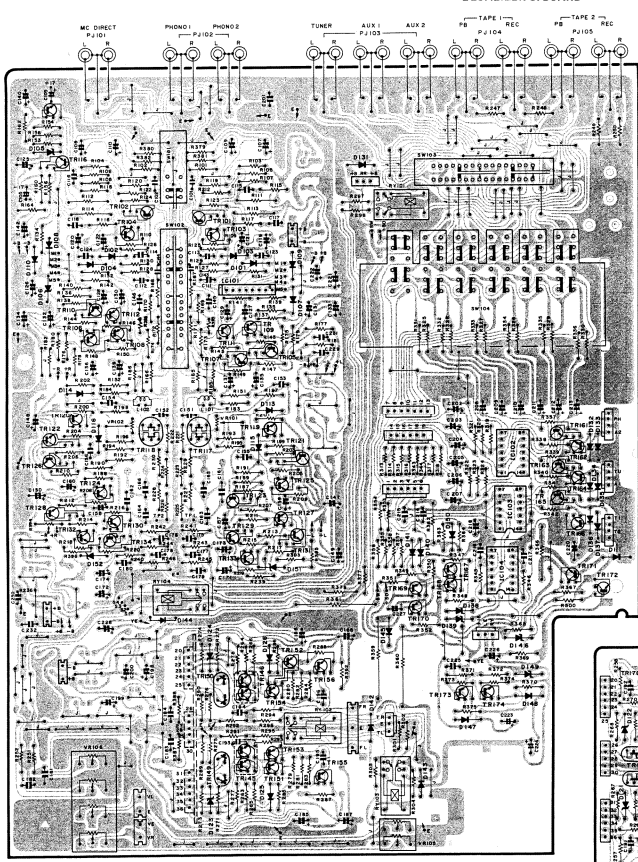

CONTROL C. BOARD

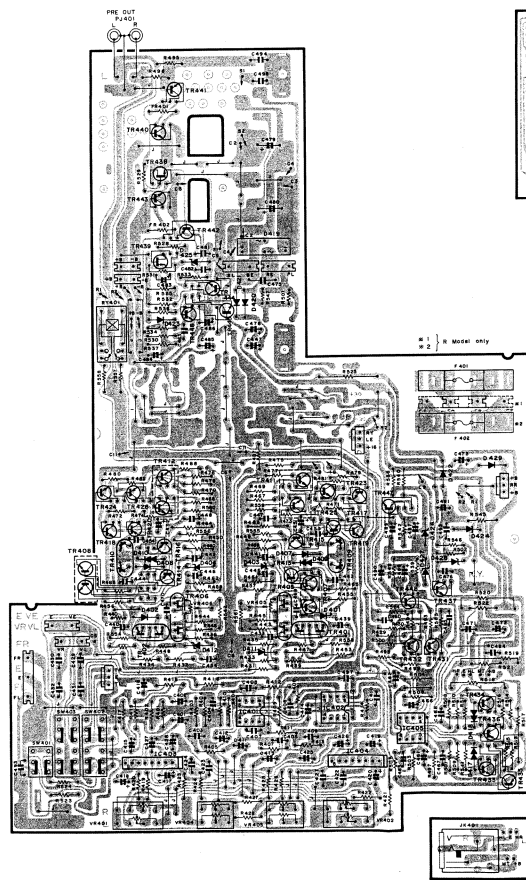

BUTTON UNIT C. BOARD

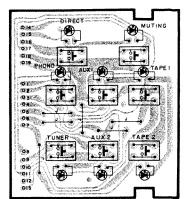

PRINTED CIRCUIT BOARD PARTS-SIDE COMPONENTS LAYOUT/WIRING

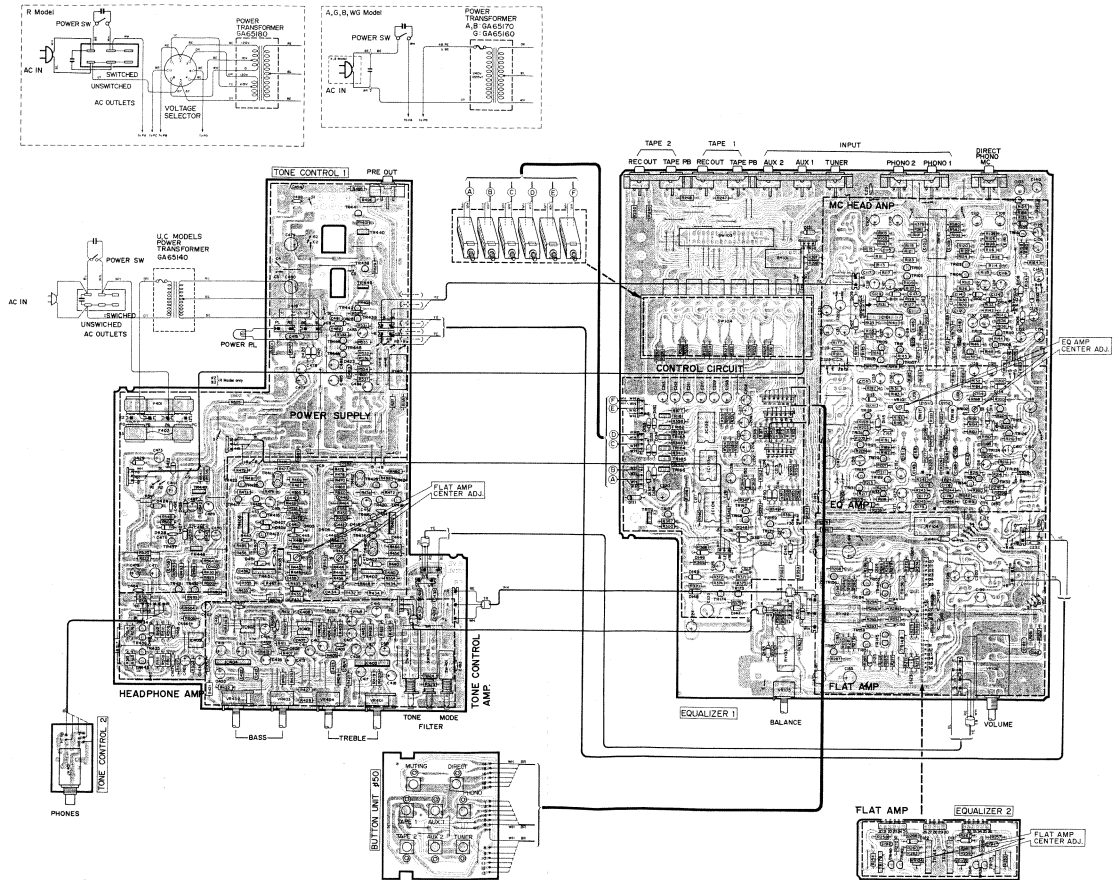

D E F G H I J K

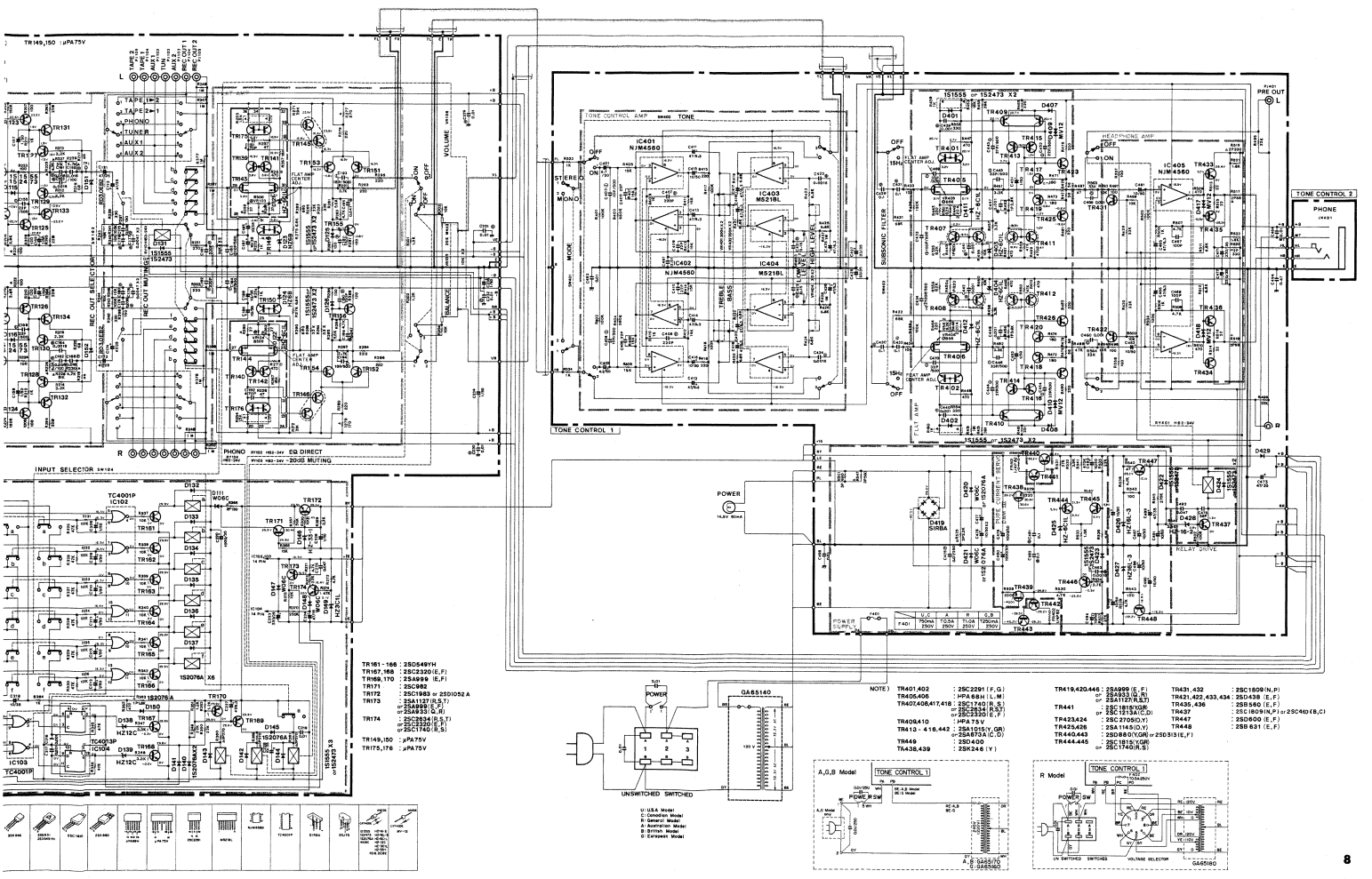

PARTS LIST

C-50

STEREO CONTROL AMPLIFIER

| ■CONTENTS | Page |
|---------------------------------|-------------|
| ■EXPLODED VIEW (Allover)..... | 1 |
| ■PARTS LIST (Allover)..... | 2 |
| ■PARTS LIST (Circuit Board) | |
| Equalizer Circuit Board..... | 4 |
| Tone Control Circuit Board..... | 11 |

Notes

DESTINATION ABBREVIATIONS

| | |
|---------|------------|
| U | U.S.A |
| C | CANADIAN |
| G | EUROPEAN |
| B | BRITISH |
| R | GENERAL |
| A | AUSTRALIAN |
| J | JAPAN |

004460

EXPLODED VIEW(Allover)

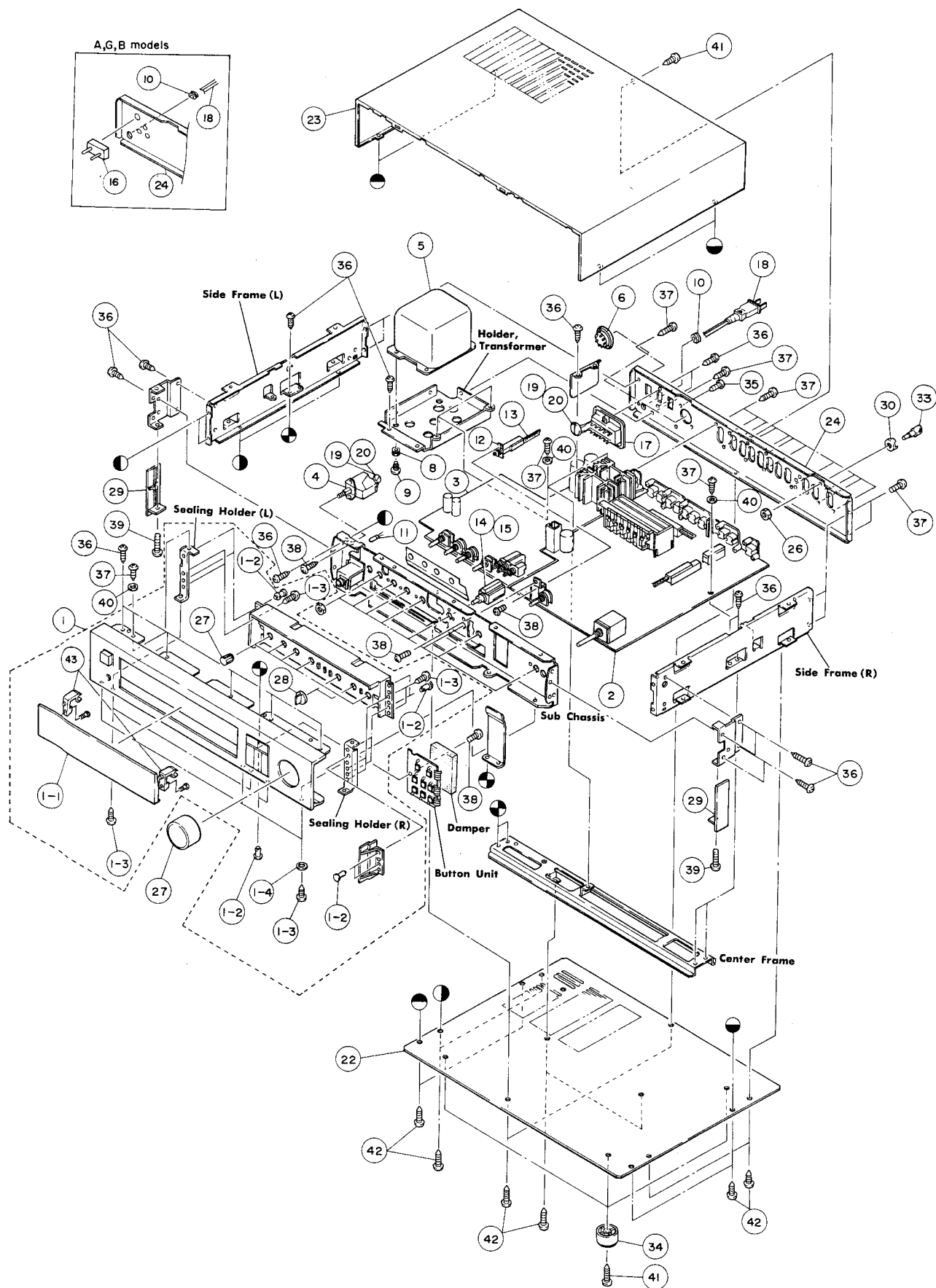

■PARTS LIST(Allover)

C-50 C-50

| Ref. No. | Part No. | Description | (部 品 名) | Remarks | Common model | Markets |
|----------|-------------|-----------------------|-------------------------|--------------|------------------|---------|
| 1 | NB:60:43:40 | Panel Unit | パネルユニット | | | |
| 1.1 | BA:08:23:40 | Sealing Panel | シーリングパネル | | | |
| 1.2 | CB:06:88:80 | Plastic Rivet | プラスチックリベット | | | |
| 1.3 | ED:33:00:60 | Bind Head Screw | M3×6(ZMC2-Bf) | 鉄バンド小ネジ | | |
| 1.4 | EV:20:30:30 | Plain Washer | M3(FCM3-Bf) | 平座金 | | |
| 2 | NA:07:84:30 | Equalizer C.Board | イコライザーシート | | J | |
| * | NA:07:84:40 | * | * | | R, U, A, G, C, B | |
| 3 | NA:07:84:50 | Tone Control C.Board | トーンコントロールシート | | J | |
| * | NA:07:84:60 | * | * | | R | |
| * | NA:07:84:70 | * | * | | U, C | |
| * | NA:07:84:80 | * | * | | A | |
| * | NA:07:84:90 | * | * | | G, B | |
| 4 | KA:80:24:70 | Push Switch | SS-13S5A/40A | プッシュスイッチ | C-70 | A, G, B |
| * | KA:80:25:50 | * | SDZIP-A TV-8 | * | * | R, U, C |
| * | KA:80:26:20 | * | SDZIP125V15A | * | * | J |
| 5 | GA:65:13:00 | Power Transformer | | 電源トランス | J | |
| * | GA:65:14:00 | * | * | * | | U, C |
| * | GA:65:16:00 | * | * | * | | G |
| * | GA:65:17:00 | * | * | * | | A, B |
| * | GA:65:18:00 | * | * | * | | R |
| 8 | LB:20:14:80 | Voltage Selector | O211 | 電圧切換器 | | R |
| 8 | CB:60:93:60 | Anti Vibration Tape | | 防振ゴム | | C-70 |
| 9 | AA:60:38:50 | Step Screw | | 段付ネジ | | A760 |
| 10 | CB:07:27:50 | Cord Stopper | SR-4N-4 | コードストッパー | | |
| 11 | JB:00:06:10 | Pilot Lamp Lead type | 14.5V 80mA | パイロットランプリード式 | | |
| 12 | KA:90:13:00 | Remote Push Switch | (Operate Section) | リモートプッシュSW | | |
| * | KA:90:28:30 | * | (Wire section) | * | | |
| 14 | KA:90:28:50 | Remote Rotary Switch | (Operate+ wire section) | リモートロータリーSW | REC OUT | |
| 15 | KA:90:28:80 | * | (*) | * | PHONO | |
| 16 | LA:00:29:50 | Relay Terminal 2P | MA0092A | 2P中継端子台 | | A, G, B |
| 17 | LB:60:39:20 | AC Outlet triplet | MD-86-4 | ACアウトレット3連 | | R, U |
| * | LB:60:43:20 | * | PMD-86-3 | * | | C |
| 18 | MG:00:12:10 | AC Cord | Black 2m 15A 250V | 電源コード | | J |
| * | MG:00:07:80 | * | 6A 250V | * | | R |
| * | MG:00:13:60 | * Flat type | 13A 125V | * | | U, C |
| * | MG:00:09:10 | * | 6A 250V | * | | G |
| * | MG:00:09:20 | * | Gray 2.5m 7.5A 250V | * | | A |
| * | MG:00:10:00 | * | Black 2m 6A 300V 500V | * | | B |
| 19 | Fi:32:41:00 | Ceramic Capacitor | 0.01μF AC 250V(IDE) | セラコン | C-70 | J |
| * | Fi:34:41:00 | * | 0.01μF MY(IDE) | * | | R, U, C |
| * | FR:16:41:00 | * | 0.01μF AC250V | * | | A, G, B |
| 20 | CB:07:21:90 | Cover for Capacitor | SB-0832-B | コンデンサーカバー角型 | | A, G, B |
| * | CB:09:52:60 | * | SB-0833 | * 丸型 | | R, U, C |
| * | CB:60:19:00 | * | HY-0103 | * 半丸型 | | J |
| 21 | CB:09:95:80 | Cover for Fuse Holder | SB-0864U | ヒューズホルダーカバー | | U |
| 22 | AA:61:01:00 | Bottom Cover | | ボトムカバー | C-70 | |
| 23 | AA:61:00:80 | Top Cover | | トップカバー | | |
| 24 | AA:61:02:40 | Rear Panel (J) | | リヤパネル | J | |
| * | AA:61:02:50 | * (R) | * | * | | R |
| * | AA:61:02:60 | * (U) | * | * | | U |
| * | AA:61:02:70 | * (G) | * | * | | G |
| * | AA:61:02:80 | * (B) | * | * | | B |

* : New Parts (新部品)

| Ref. No. | Part No. | Description | (部 品 名) | Remarks | Common model | Markets |
|----------|-------------|-------------------------|---------------|-------------|--------------|---------|
| 25 | BA:08:23:60 | Knob | | ツマミ | | C-70 |
| 26 | AA:09:57:20 | Bonding Nut | | ボンディングナット | | CA810 |
| 27 | CB:60:76:70 | Knob | | ツマミ | | C-70 |
| 28 | CB:60:76:80 | Knob, Switch | | SWツマミ | | * |
| 29 | CB:60:76:90 | Slide Plate | | サイドプレート | | * |
| 30 | CB:60:93:40 | Shield Plate | | シールドプレート | | * |
| 32 | CB:09:93:40 | Saucer | | 皿皿 | | |
| 33 | NB:08:14:80 | Terminal Unit | | ターミナルユニット | | CA-1010 |
| 34 | CB:07:59:00 | Leg | | 脚 | | |
| 35 | CB:06:88:80 | Plastic Rivet | | プラスチックリベット | | R |
| 36 | EN:33:00:10 | Bind Head Tapping Screw | 3×8(FCM3-Bf) | 鉄バンドタッピングネジ | Type-II | |
| 37 | EN:03:00:20 | * | 3×8(ZMC2-Y) | * | | |
| 38 | ED:33:00:60 | Bind Head Screw | M3×6(ZMC2-Bf) | 鉄バンド小ネジ | | |
| 39 | ED:33:01:40 | * | M3×14(*) | * | | |
| 40 | EV:20:30:00 | Plain Washer | M3(ZMC2-Y) | 平座金 | | |
| 41 | Ei:33:01:40 | Bind Head Tapping Screw | 3×14(ZMC2-Bf) | 鉄バンドタッピングネジ | | |
| 42 | Ei:33:00:80 | * | 3×8(FCM3-Bf) | * | | |
| 43 | CB:60:76:30 | Hinge | | ヒンジ | | |
| | | Accessories Assembly | | 付属品Ass'y | | M-50 |
| | Mi:06:99:20 | Pin Cord | 1m | ピンコード | | |

* : New Parts (新部品)

■PARTS LIST(Circuit Board)

C-50 C-50

| Ref No. | Part No. | Description | (部 品 名) | Remarks | Common model | Markets |
|---------|-------------|-----------------------------|----------|---------|--------------|-------------|
| | NA 07 84 40 | Equalizer Circuit Board | イコライザシート | | | R,U,A,G,C,B |
| C101 | UA 25 41 00 | Mylar Capacitor | マイラーコン | | | |
| C102 | UA 25 41 00 | Mylar Capacitor | マイラーコン | | | |
| C103 | UW 95 71 00 | Electrolytic Capacitor | ケミコン | | | |
| C107 | UW 91 82 20 | Electrolytic Capacitor | ケミコン | | | |
| C110 | UA 25 31 00 | Mylar Capacitor | マイラーコン | | | |
| C111 | UA 25 31 00 | Mylar Capacitor | マイラーコン | | | |
| C119 | UW 96 61 00 | Electrolytic Capacitor | ケミコン | | | |
| C123 | FT 51 21 00 | Polypropylene Capacitor NP | ポリプロコン | | | |
| C124 | FT 51 21 00 | Polypropylene Capacitor NP | ポリプロコン | | | |
| C125 | UW 83 72 20 | Electrolytic Capacitor | ケミコン | | | |
| C126 | UW 83 72 20 | Electrolytic Capacitor | ケミコン | | | |
| C127 | UW 96 63 30 | Electrolytic Capacitor | ケミコン | | | |
| C131 | UW 94 81 00 | Electrolytic Capacitor | ケミコン | | | |
| C134 | UW 94 81 00 | Electrolytic Capacitor | ケミコン | | | |
| C136 | UW 94 71 00 | Electrolytic Capacitor | ケミコン | | | |
| C138 | UW 94 71 00 | Electrolytic Capacitor | ケミコン | | | |
| C140 | UW 95 73 30 | Electrolytic Capacitor | ケミコン | | | |
| C142 | UW 95 73 30 | Electrolytic Capacitor | ケミコン | | | |
| C143 | FT 51 21 20 | Polypropylene Capacitor NP | ポリプロコン | | | |
| C144 | FT 51 21 20 | Polypropylene Capacitor NP | ポリプロコン | | | |
| C145 | FT 51 22 20 | Electrolytic Capacitor | ケミコン | | | |
| C147 | UW 95 71 00 | Electrolytic Capacitor | ケミコン | | | |
| C150 | UW 95 71 00 | Electrolytic Capacitor | ケミコン | | | |
| C151 | FT 51 21 00 | Polypropylene Capacitor NP | ポリプロコン | | | |
| C152 | FT 51 25 60 | Electrolytic Capacitor | ケミコン | | | |
| C153 | FT 51 25 60 | Electrolytic Capacitor | ケミコン | | | |
| C154 | FT 51 25 60 | Electrolytic Capacitor | ケミコン | | | |
| C155 | FT 51 25 60 | Electrolytic Capacitor | ケミコン | | | |
| C156 | FU 35 12 20 | Mica Capacitor FE | マイカコン | | | |
| C157 | UW 86 61 00 | Electrolytic Capacitor | ケミコン | | | |
| C158 | UW 86 61 00 | Electrolytic Capacitor | ケミコン | | | |
| C161 | FT 86 45 60 | Polypropylene Capacitor APS | ポリプロコン | | | |
| C162 | UA 25 31 50 | Mylar Capacitor | マイラーコン | | | |
| C163 | UA 25 31 50 | Mylar Capacitor | マイラーコン | | | |
| C165 | FT 66 41 60 | Polypropylene Capacitor APS | ポリプロコン | | | |
| C166 | FT 66 41 60 | Polypropylene Capacitor APS | ポリプロコン | | | |
| C171 | UW 94 74 70 | Electrolytic Capacitor | ケミコン | | | |
| C174 | UW 94 74 70 | Electrolytic Capacitor | ケミコン | | | |
| C175 | UA 25 43 60 | Mylar Capacitor | マイラーコン | | | |
| C176 | UA 25 43 60 | Mylar Capacitor | マイラーコン | | | |
| C177 | UA 25 34 70 | Mylar Capacitor | マイラーコン | | | |
| C178 | UA 25 34 70 | Mylar Capacitor | マイラーコン | | | |
| C181 | FT 51 22 20 | Polypropylene Capacitor NP | ポリプロコン | | | |
| C182 | FT 51 22 20 | Polypropylene Capacitor NP | ポリプロコン | | | |
| C183 | FU 35 11 00 | Mica Capacitor FE | マイカコン | | | |
| C184 | FU 35 11 00 | Mica Capacitor FE | マイカコン | | | |
| C186 | UW 95 71 00 | Electrolytic Capacitor | ケミコン | | | |
| C189 | FT 51 21 50 | Polypropylene Capacitor NP | ポリプロコン | | | |
| C190 | FT 51 21 50 | Polypropylene Capacitor NP | ポリプロコン | | | |
| C191 | FT 51 24 70 | Electrolytic Capacitor | ケミコン | | | |
| C192 | FT 51 24 70 | Electrolytic Capacitor | ケミコン | | | |
| C193 | FT 51 24 70 | Electrolytic Capacitor | ケミコン | | | |
| C194 | FU 35 11 50 | Mica Capacitor FE | マイカコン | | | |
| C195 | UA 25 44 70 | Mylar Capacitor | マイラーコン | | | |
| C196 | UA 25 44 70 | Mylar Capacitor | マイラーコン | | | |
| C201 | FG 44 41 00 | Ceramic Capacitor | セラコン | | | |
| C202 | UW 96 63 30 | Electrolytic Capacitor | ケミコン | | | |
| C207 | UW 96 63 30 | Electrolytic Capacitor | ケミコン | | | |
| C208 | UW 86 61 00 | Electrolytic Capacitor | ケミコン | | | |
| C213 | FG 44 44 70 | Ceramic Capacitor | セラコン | | | |
| C214 | FG 44 44 70 | Ceramic Capacitor | セラコン | | | |
| C216 | FG 41 31 00 | Ceramic Capacitor | セラコン | | | |
| C217 | FG 41 31 00 | Ceramic Capacitor | セラコン | | | |
| C218 | UW 84 71 00 | Electrolytic Capacitor | ケミコン | | | |
| C219 | FG 44 41 00 | Ceramic Capacitor | セラコン | | | |

* : New Parts (新部品)

| Ref No. | Part No. | Description | (部 品 名) | Remarks | Common model | Markets |
|---------|-------------|--------------------------------|---------------------|---------|--------------|---------|
| C220 | UW 95 91 00 | Electrolytic Capacitor | ケミコン | | | |
| C221 | UW 83 72 20 | Electrolytic Capacitor | ケミコン | | | |
| C222 | UW 83 72 20 | Electrolytic Capacitor | ケミコン | | | |
| C223 | UW 94 83 30 | Electrolytic Capacitor | ケミコン | | | |
| C224 | UW 83 74 70 | Electrolytic Capacitor | ケミコン | | | |
| C225 | FG 44 44 70 | Ceramic Capacitor | セラコン | | | |
| C226 | UW 86 61 00 | Electrolytic Capacitor | ケミコン | | | |
| C227 | UW 91 74 70 | Electrolytic Capacitor | ケミコン | | | |
| C228 | UW 95 71 00 | Electrolytic Capacitor | ケミコン | | | |
| C229 | FG 44 41 00 | Ceramic Capacitor | セラコン | | | |
| C232 | FG 44 41 00 | Ceramic Capacitor | セラコン | | | |
| L101 | GE 90 03 30 | Ferrite Shield Type Choke Coil | フェライトシールドタイプチョークコイル | | | |
| L102 | GE 90 03 30 | Ferrite Shield Type Choke Coil | フェライトシールドタイプチョークコイル | | | |
| R101 | HJ 35 51 50 | Carbon Resistor | カーボン抵抗 | | | |
| R102 | HJ 35 51 50 | Carbon Resistor | カーボン抵抗 | | | |
| R103 | HJ 35 73 30 | Carbon Resistor | カーボン抵抗 | | | |
| R104 | HJ 35 73 30 | Carbon Resistor | カーボン抵抗 | | | |
| R105 | HJ 35 71 80 | Carbon Resistor | カーボン抵抗 | | | |
| R106 | HJ 35 71 80 | Carbon Resistor | カーボン抵抗 | | | |
| R107 | HJ 35 71 80 | Carbon Resistor | カーボン抵抗 | | | |
| R108 | HJ 35 71 80 | Carbon Resistor | カーボン抵抗 | | | |
| R109 | HJ 35 71 80 | Carbon Resistor | カーボン抵抗 | | | |
| R110 | HL 71 81 20 | Metal Oxide Film Resistor | 酸化抵抗フォーミング | | | |
| R111 | HJ 35 51 00 | Carbon Resistor | カーボン抵抗 | | | |
| R112 | HJ 35 51 00 | Carbon Resistor | カーボン抵抗 | | | |
| R113 | HJ 35 55 60 | Carbon Resistor | カーボン抵抗 | | | |
| R114 | HJ 35 55 60 | Carbon Resistor | カーボン抵抗 | | | |
| R115 | HJ 35 55 60 | Carbon Resistor | カーボン抵抗 | | | |
| R116 | HJ 35 55 60 | Carbon Resistor | カーボン抵抗 | | | |
| R117 | HJ 35 55 60 | Carbon Resistor | カーボン抵抗 | | | |
| R118 | HJ 35 55 60 | Carbon Resistor | カーボン抵抗 | | | |
| R119 | HJ 35 55 60 | Carbon Resistor | カーボン抵抗 | | | |
| R120 | HJ 35 55 60 | Carbon Resistor | カーボン抵抗 | | | |
| R121 | HJ 35 55 60 | Carbon Resistor | カーボン抵抗 | | | |
| R122 | HJ 35 55 60 | Carbon Resistor | カーボン抵抗 | | | |
| R123 | HJ 35 55 60 | Carbon Resistor | カーボン抵抗 | | | |
| R124 | HJ 35 55 60 | Carbon Resistor | カーボン抵抗 | | | |
| R125 | HJ 35 55 60 | Carbon Resistor | カーボン抵抗 | | | |
| R126 | HJ 35 55 60 | Carbon Resistor | カーボン抵抗 | | | |
| R127 | HJ 35 55 60 | Carbon Resistor | カーボン抵抗 | | | |
| R128 | HJ 35 55 60 | Carbon Resistor | カーボン抵抗 | | | |
| R129 | HJ 35 55 60 | Carbon Resistor | カーボン抵抗 | | | |
| R130 | HJ 35 55 60 | Carbon Resistor | カーボン抵抗 | | | |
| R131 | HJ 35 64 70 | Carbon Resistor | カーボン抵抗 | | | |
| R132 | HJ 35 64 70 | Carbon Resistor | カーボン抵抗 | | | |
| R133 | HJ 35 61 80 | Carbon Resistor | カーボン抵抗 | | | |
| R134 | HJ 35 61 80 | Carbon Resistor | カーボン抵抗 | | | |
| R135 | HJ 35 72 20 | Carbon Resistor | カーボン抵抗 | | | |
| R136 | HJ 35 72 20 | Carbon Resistor | カーボン抵抗 | | | |
| R137 | HJ 35 64 70 | Carbon Resistor | カーボン抵抗 | | | |
| R138 | HJ 35 64 70 | Carbon Resistor | カーボン抵抗 | | | |
| R139 | HJ 35 61 00 | Carbon Resistor | カーボン抵抗 | | | |
| R140 | HJ 35 61 00 | Carbon Resistor | カーボン抵抗 | | | |
| R141 | HJ 35 43 90 | Carbon Resistor | カーボン抵抗 | | | |
| R142 | HJ 35 43 90 | Carbon Resistor | カーボン抵抗 | | | |
| R143 | HJ 35 45 60 | Carbon Resistor | カーボン抵抗 | | | |
| R144 | HJ 35 45 60 | Carbon Resistor | カーボン抵抗 | | | |
| R145 | HJ 35 45 60 | Carbon Resistor | カーボン抵抗 | | | |
| R146 | HJ 35 45 60 | Carbon Resistor | カーボン抵抗 | | | |
| R147 | HJ 35 45 60 | Carbon Resistor | カーボン抵抗 | | | |
| R148 | HJ 35 45 60 | Carbon Resistor | カーボン抵抗 | | | |
| R149 | HJ 35 45 60 | Carbon Resistor | カーボン抵抗 | | | |
| R150 | HJ 35 45 60 | Carbon Resistor | カーボン抵抗 | | | |
| R151 | HJ 35 45 60 | Carbon Resistor | カーボン抵抗 | | | |
| R152 | HJ 35 45 60 | Carbon Resistor | カーボン抵抗 | | | |
| R153 | HJ 35 45 60 | Carbon Resistor | カーボン抵抗 | | | |
| R154 | HJ 35 45 60 | Carbon Resistor | カーボン抵抗 | | | |
| R155 | HJ 35 45 60 | Carbon Resistor | カーボン抵抗 | | | |
| R156 | HJ 35 45 60 | Carbon Resistor | カーボン抵抗 | | | |
| R157 | HJ 35 45 60 | Carbon Resistor | カーボン抵抗 | | | |
| R158 | HJ 35 45 60 | Carbon Resistor | カーボン抵抗 | | | |
| R159 | HJ 35 45 60 | Carbon Resistor | カーボン抵抗 | | | |
| R160 | HJ 35 45 60 | Carbon Resistor | カーボン抵抗 | | | |
| R161 | HJ 35 72 70 | Carbon Resistor | カーボン抵抗 | | | |
| R162 | HJ 35 72 70 | Carbon Resistor | カーボン抵抗 | | | |
| R163 | HJ 35 81 00 | Carbon Resistor | カーボン抵抗 | | | |
| R164 | HJ 35 81 00 | Carbon Resistor | カーボン抵抗 | | | |
| R165 | HJ 35 81 00 | Carbon Resistor | カーボン抵抗 | | | |
| R166 | HJ 35 81 00 | Carbon Resistor | カーボン抵抗 | | | |
| R167 | HJ 35 92 20 | Carbon Resistor | カーボン抵抗 | | | |
| R168 | HJ 35 92 20 | Carbon Resistor | カーボン抵抗 | | | |
| R169 | HJ 35 92 20 | Carbon Resistor | カーボン抵抗 | | | |
| R170 | HJ 35 92 20 | Carbon Resistor | カーボン抵抗 | | | |
| R171 | HJ 35 51 00 | Carbon Resistor | カーボン抵抗 | | | |
| R172 | HJ 35 51 00 | Carbon Resistor | カーボン抵抗 | | | |
| R173 | HJ 35 51 00 | Carbon Resistor | カーボン抵抗 | | | |
| R174 | HJ 35 51 00 | Carbon Resistor | カーボン抵抗 | | | |
| R175 | HJ 35 55 60 | Carbon Resistor | カーボン抵抗 | | | |
| R176 | HJ 35 55 60 | Carbon Resistor | カーボン抵抗 | | | |
| R177 | HJ 35 55 60 | Carbon Resistor | カーボン抵抗 | | | |
| R178 | HJ 35 55 60 | Carbon Resistor | カーボン抵抗 | | | |
| R179 | HJ 35 52 20 | Carbon Resistor | カーボン抵抗 | | | |
| R180 | HJ 35 52 20 | Carbon Resistor | カーボン抵抗 | | | |
| R181 | HJ 35 74 70 | Carbon Resistor | カーボン抵抗 | | | |
| R182 | HJ 35 74 70 | Carbon Resistor | カーボン抵抗 | | | |
| R183 | HJ 35 51 80 | Carbon Resistor | カーボン抵抗 | | | |
| R184 | HJ 35 51 80 | Carbon Resistor | カーボン抵抗 | | | |
| R185 | HJ 35 62 20 | Carbon Resistor | カーボン抵抗 | | | |
| R186 | HJ 35 62 20 | Carbon Resistor | カーボン抵抗 | | | |
| R187 | HJ 35 62 20 | Carbon Resistor | カーボン抵抗 | | | |
| R188 | HJ 35 62 20 | Carbon Resistor | カーボン抵抗 | | | |
| R189 | HJ 35 43 30 | Carbon Resistor | カーボン抵抗 | | | |
| R190 | HJ 35 43 30 | Carbon Resistor | カーボン抵抗 | | | |
| R191 | HJ 35 51 50 | Carbon Resistor | カーボン抵抗 | | | |
| R192 | HJ 35 51 50 | Carbon Resistor | カーボン抵抗 | | | |
| R193 | HJ 35 51 50 | Carbon Resistor | カーボン抵抗 | | | |
| R194 | HJ 35 51 50 | Carbon Resistor | カーボン抵抗 | | | |
| R195 | HJ 35 51 80 | Carbon Resistor | カーボン抵抗 | | | |
| R196 | HJ 35 51 80 | Carbon Resistor | カーボン抵抗 | | | |
| R197 | HJ 35 51 80 | Carbon Resistor | カーボン抵抗 | | | |
| R198 | HJ 35 51 80 | Carbon Resistor | カーボン抵抗 | | | |
| R199 | HJ 35 51 80 | Carbon Resistor | カーボン抵抗 | | | |
| R200 | HJ 35 81 50 | Carbon Resistor | カーボン抵抗 | | | |
| R201 | HJ 35 81 50 | Carbon Resistor | カーボン抵抗 | | | |
| R202 | HJ 35 81 50 | Carbon Resistor | カーボン抵抗 | | | |
| R203 | HJ 35 81 50 | Carbon Res | | | | |

| Ref. No. | Part No. | Description | (部 品 名) | Remarks | Common model | Markets |
|----------------|-------------|---------------------------|------------------|------------|--------------|---------|
| R223 R224 | HJ 35 51 00 | Carbon Resistor | 100Ω RD25 | カーボン抵抗 | | |
| R225 R226 | HU 57 64 30 | Metal Film Resistor | 4.3KΩ SN14K2E(F) | 金属被膜抵抗 | | |
| R227 R228 | HU 57 75 10 | " | 51KΩ " | " | | |
| R229 R230 | HU 57 64 70 | " | 4.7KΩ " | " | | |
| | | | | | | |
| R239 R240 | HJ 35 53 30 | Carbon Resistor | 330Ω RD25 | カーボン抵抗 | | |
| R241 R242 | HJ 35 81 00 | " | 100KΩ " | " | | |
| R243 R246 | HJ 35 71 00 | " | 10KΩ " | " | | |
| R247 R250 | HJ 35 91 00 | " | 1MΩ " | " | | |
| R251 R252 | HJ 35 52 20 | " | 220Ω " | " | | |
| R253 R254 | HZ 00 25 20 | Metal Film Resistor | 1.5KΩ SN14K2E(F) | デュアル金属被膜抵抗 | | |
| R257 R258 | HJ 35 44 70 | Carbon Resistor | 47Ω RD25 | カーボン抵抗 | | |
| * R259 R262 | HU 57 42 70 | Metal Film Resistor | 27Ω SN14K2E(F) | 金属被膜抵抗 | | |
| R263 R266 | HJ 35 73 30 | Carbon Resistor | 33KΩ RD25 | カーボン抵抗 | | |
| R267 R268 | HJ 35 71 80 | " | 18KΩ " | " | | |
| R269 R270 | HJ 35 54 70 | " | 470Ω " | " | | |
| R271 R272 | HJ 35 73 90 | " | 39KΩ " | " | | |
| R273 R274 | HJ 35 61 00 | " | 1KΩ " | " | | |
| R275 R276 | HJ 35 66 80 | " | 6.8KΩ " | " | | |
| R277 R278 | HU 57 52 70 | Metal Film Resistor | 270Ω SN14K2E(F) | 金属被膜抵抗 | | |
| R279 R280 | HJ 35 52 20 | Carbon Resistor | 220Ω RD25 | カーボン抵抗 | | |
| R281 R282 | HJ 35 65 60 | " | 5.6KΩ " | " | | |
| R283 R284 | HJ 35 64 70 | " | 4.7KΩ " | " | | |
| R285 R288 | HJ 35 51 20 | " | 120Ω " | " | | |
| R289 R290 | HJ 35 56 80 | " | 680Ω " | " | | |
| R291 R292 | HJ 35 62 70 | " | 2.7KΩ " | " | | |
| R293 R296 | HJ 35 52 20 | " | 220Ω " | " | | |
| R297 R298 | HJ 35 51 50 | " | 150Ω " | " | | |
| | | | | | | |
| R300 | HJ 35 51 00 | Carbon Resistor | 100Ω RD25 | カーボン抵抗 | | |
| R301 R302 | HJ 35 61 20 | " | 1.2KΩ " | " | | |
| R303 R304 | HJ 35 71 00 | " | 10KΩ " | " | | |
| | | | | | | |
| R313 R318 | HJ 35 71 00 | Carbon Resistor | 10KΩ RD25 | カーボン抵抗 | | |
| R319 R324 | HJ 35 81 00 | " | 100KΩ " | " | | |
| R325 R330 | HJ 35 74 70 | " | 47KΩ " | " | | |
| R331 R336 | HJ 35 81 00 | " | 100KΩ " | " | | |
| R337 R344 | HJ 35 71 00 | " | 10KΩ " | " | | |
| R345 R346 | HJ 35 74 70 | " | 47KΩ " | " | | |
| R347 R348 | HJ 35 63 30 | " | 3.3KΩ " | " | | |
| R349 R350 | HJ 35 72 20 | " | 22KΩ " | " | | |
| R351 R352 | HJ 35 61 20 | " | 1.2KΩ " | " | | |
| R353 R356 | HJ 35 61 00 | " | 1KΩ " | " | | |
| R357 R358 | HJ 35 58 20 | " | 820Ω " | " | | |
| * R359 R361 | HL 73 52 70 | Metal Oxide Film Resistor | 270Ω 3P | 酸金抵抗フォーミング | | |
| * R362 | HL 71 61 80 | " | 1.8KΩ 1P | " | | |
| R363 | HJ 35 54 70 | Carbon Resistor | 470Ω RD25 | カーボン抵抗 | | |
| R364 | HJ 35 61 00 | " | 1KΩ " | " | | |
| | | | | | | |
| R366 | HL 72 51 50 | Metal Oxide Film Resistor | 150Ω 2P | 酸金抵抗フォーミング | | |

* : New Parts (新部品)

| Ref. No. | Part No. | Description | (部 品 名) | Remarks | Common model | Markets |
|------------------|-------------|-----------------------------|---|-----------|--------------------------------|---------|
| R367 | HJ:35:75:60 | Carbon Resistor | 56K Ω RD25 | カーボン抵抗 | | |
| R368 | HJ:35:71:50 | " | 15K Ω " | " | | |
| R369 | HJ:35:63:30 | " | 3.3K Ω " | " | | |
| R370 | HJ:35:82:20 | " | 220K Ω " | " | | |
| R371 R372 | HJ:35:64:70 | " | 4.7K Ω " | " | | |
| R373 | HJ:35:72:20 | " | 22K Ω " | " | | |
| R374 | HJ:35:74:70 | " | 47K Ω " | " | | |
| R375 | HJ:35:71:20 | " | 12K Ω " | " | | |
| R377 R378 | HJ:35:91:00 | " | 1M Ω " | " | | |
| * R379 ~382 | HU:57:31:00 | Metal Film Resistor | 1 Ω SN14K2E(F) | 金属被膜抵抗 | | |
| R387 R388 | HJ:35:91:00 | Carbon Resistor | 1M Ω RD25 | カーボン抵抗 | | |
| R393 ~396 | HV:35:42:20 | Flame Proof Carbon Resistor | 22 Ω RDF25SF | 不燃化カーボン抵抗 | | |
| VR101 VR102 | HY:00:09:60 | Semi Variable Resistor | B100 Ω | 半固定ボリューム | | |
| * VR103 VR104 | HT:18:02:40 | " | B500 Ω TM8KHI-IS | メタルグレースVR | | |
| * VR105 | HS:41:15:40 | Variable Resistor | 20K Ω MN \times 2 | ボリューム1軸2連 | (BALANCE) | |
| * VR106 | HY:00:14:10 | " | 50K Ω 特 \times 2 +10K Ω 特 \times 2 | " ミニディテント | (VOLUME) | |
| TR101 TR102 | iD:07:86:00 | Transistor | 2SD786(Q,R,S) | トランジスタ | | |
| TR103 TR104 | iB:07:37:00 | " | 2SB737(Q,R,S) | " | | |
| TR105 TR106 | iC:12:13:10 | " | 2SC1213A(C,D) | " | } Inter- changeable (併用) | |
| " | iC:18:15:80 | " | 2SC1815(Y,GR) | " | | |
| TR107 TR108 | iA:06:73:10 | " | 2SA673A(C,D) | " | } Inter- changeable (併用) | |
| " | iA:10:15:30 | " | 2SA1015(Y,GR) | " | | |
| TR109 TR110 | iC:17:40:00 | " | 2SC1740(R,S) | " | } Inter- changeable (併用) | |
| " | iC:23:20:10 | " | 2SC2320(E,F) | " | | |
| * " | iC:26:34:00 | " | 2SC2634(R,S,T) | " | | |
| TR111 TR112 | iA:09:33:00 | " | 2SA933(Q,R) | " | } Inter- changeable (併用) | |
| " | iA:09:99:10 | " | 2SA999(E,F) | " | | |
| * " | iA:11:27:00 | " | 2SA1127(R,S,T) | " | | |
| TR114 | iC:12:13:10 | " | 2SC1213A(C,D) | " | } Inter- changeable (併用) | |
| " | iC:18:15:80 | " | 2SC1815(Y,GR) | " | | |
| TR116 | iA:06:73:10 | " | 2SA673A(C,D) | " | } Inter- changeable (併用) | |
| " | iA:10:15:30 | " | 2SA1015(Y,GR) | " | | |
| * TR117 TR118 | iE:20:05:10 | Dual FET | 2SJ75(GR,BL) | デュアルFET | | |
| TR119 TR120 | iC:17:40:00 | Transistor | 2SC1740(R,S) | トランジスタ | } Inter- changeable (併用) | |
| " | iC:23:20:10 | " | 2SC2320(E,F) | " | | |
| * " | iC:26:34:00 | " | 2SC2634(R,S,T) | " | | |
| TR121 TR122 | iC:12:13:10 | " | 2SC1213A(C,D) | " | } Inter- changeable (併用) | |
| " | iC:18:15:80 | " | 2SC1815(Y,GR) | " | | |
| TR123 TR124 | iA:06:73:10 | " | 2SA673A(C,D) | " | } Inter- changeable (併用) | |
| " | iA:10:15:30 | " | 2SA1015(Y,GR) | " | | |
| TR125 TR126 | iC:12:13:10 | " | 2SC1213A(C,D) | " | } Inter- changeable (併用) | |
| " | iC:18:15:80 | " | 2SC1815(Y,GR) | " | | |
| TR127 TR128 | iC:17:40:00 | " | 2SC1740(R,S) | " | } Inter- changeable (併用) | |
| " | iC:23:20:10 | " | 2SC2320(E,F) | " | | |
| * " | iC:26:34:00 | " | 2SC2634(R,S,T) | " | | |

* : New Parts (新部品)

| Ref. No. | Part No. | Description | (部 品 名) | Remarks | Common model | Markets |
|----------------|-------------|-----------------|------------------|------------|--------------------------|---------|
| TR129 TR130 | iA 09:33:00 | Transistor | 2SA933(Q,R) | トランジスタ | Inter-changeable (併用) | |
| " | iA 09:99:10 | " | 2SA999(E,F) | " | | |
| " | iA 11:27:00 | " | 2SA1127(R,R,T) | " | | |
| TR131 TR132 | iD 04:38:10 | " | 2SD438(E,F) | " | Inter-changeable (併用) | |
| TR133 TR134 | iB 05:60:10 | " | 2SB560(E,F) | " | | |
| TR139 -142 | iC 17:40:00 | " | 2SC1740(R,S) | " | | |
| " | iC 23:20:10 | " | 2SC2320(E,F) | " | Inter-changeable (併用) | |
| " | iC 26:34:00 | " | 2SC2634(R,S,T) | " | | |
| TR143 TR144 | iE 10:19:10 | Dual FET | μ PA68H(L,M) | デュアルFET | | |
| TR145 TR146 | iZ 00:02:00 | Twin Transistor | 2SC1815(O,Y) | ツイントランジスタ | | |
| TR149 TR150 | iZ 00:01:20 | Dual Transistor | μ PA74V | デュアルトランジスタ | | |
| TR151 -154 | iA 06:73:10 | Transistor | 2SA673A(C,D) | トランジスタ | | |
| " | iA 10:15:30 | " | 2SA1015(Y,GR) | " | | |
| TR155 TR156 | iC 27:05:00 | " | 2SC2705(O,Y) | " | | |
| TR161 -166 | iC 23:24:00 | Transistor | 2SC2324K | トランジスタ | Inter-changeable (併用) | |
| " | iD 05:49:00 | " | 2SD549YH(35V) | " | | |
| TR167 TR168 | iC 23:20:10 | " | 2SC2320(E,F) | " | | |
| TR169 TR170 | iA 09:99:10 | " | 2SA999(E,F) | " | | |
| TR171 | iC 09:82:00 | " | 2SC982 | " | | |
| TR172 | iC 19:83:00 | " | 2SC1983 | " | Inter-changeable (併用) | |
| " | iD 10:52:10 | " | 2SD1052A | " | | |
| TR173 | iA 09:33:00 | " | 2SA933(Q,R) | " | Inter-changeable (併用) | |
| " | iA 09:99:10 | " | 2SA999(E,F) | " | | |
| " | iA 11:27:00 | " | 2SA1127(R,S,T) | " | | |
| TR174 | iC 17:40:00 | " | 2SC1740(R,S) | " | Inter-changeable (併用) | |
| " | iC 23:20:10 | " | 2SC2320(E,F) | " | | |
| " | iC 26:34:00 | " | 2SC2634(R,S,T) | " | | |
| TR175 TR176 | iZ 00:01:30 | Dual Transistor | μ PA75V | デュアルトランジスタ | | |
| D101 -104 | iF 00:00:40 | Diode | IS1555 | ダイオード | Inter-changeable (併用) | |
| " | iF 00:06:70 | " | IS2473 | " | | |
| D105 D106 | iF 00:14:10 | Zener Diode | HZ-9B | ツェナーダイオード | | |
| D107 -110 | iF 00:00:40 | Diode | IS1555 | ダイオード | Inter-changeable (併用) | |
| " | iF 00:06:70 | " | IS2473 | " | | |
| D111 | iH 00:07:10 | " | W06C | " | | |
| D113 -116 | iF 00:00:40 | Diode | IS1555 | ダイオード | Inter-changeable (併用) | |
| " | iF 00:06:70 | " | IS2473 | " | | |
| D121 D122 | iF 00:15:10 | Zener Diode | HZ-6CIL | ツェナーダイオード | | |
| D123 D124 | iF 00:10:70 | " | HZ6B | " | | |
| D125 D126 | iF 00:00:40 | Diode | IC1555 | ダイオード | Inter-changeable (併用) | |
| " | iF 00:06:70 | " | IS2473 | " | | |
| D131 | iF 00:00:40 | Diode | IS1555 | ダイオード | Inter-changeable (併用) | |
| " | iF 00:06:70 | " | IS2473 | " | | |

* : New Parts (新部品)

| Ret. No. | Part No. | Description | (部 品 名) | Remarks | Common model | Markets |
|------------------|--------------------------|-------------------------|----------------------|---------------|------------------------------|---------|
| D132 ~137 | iF 00 16 20 | Diode | IS2076A | ダイオード | | |
| D138 D139 | iF 00 05 50 | Zener Diode | HZ12C | ツェナーダイオード | | |
| D140 D141 | iF 00 16 20 | Diode | IS2076A | ダイオード | | |
| D142 ~144 | iF 00 00 40 | " | IS1555 | " | Inter- changeable (併用) | |
| " | iF 00 06 70 | " | IS2473 | " | | |
| D145 | iF 00 16 20 | " | IS2076A | " | | |
| * D146 | iF 00 37 30 | Zener Diode | HZ-33-1 | ツェナーダイオード | | |
| D147 | iH 00 07 10 | Diode | W06C | ダイオード | | |
| D148 | iF 00 00 40 | " | IS1555 | " | } | |
| " | iF 00 06 70 | " | IS2473 | " | | |
| * D149 | iF 00 34 80 | Zener Diode | HZ3C1 | ツェナーダイオード | | |
| D150 | iF 00 16 20 | Diode | IS2076A | ダイオード | | |
| * D151 D152 | iF 00 18 40 | Zener Diode | RD3.0EB2 | ツェナーダイオード | | |
| * IC101 | iG 05 82 00 | IC | M5218L | IC | | |
| IC102 IC103 | iG 00 11 70 | " | TC4001P | " | | |
| IC104 | iG 00 11 80 | " | TC4013P | " | | |
| * SW101 | KA 90 28 40 | Remote Push Switch S | 2-2 | リモートプッシュスイッチ | | |
| * SW103 | KA 90 28 70 | Remote Rotary Switch NS | 4-6 | リモートルォタリースイッチ | | |
| * SW104 | KA 90 27 90 | Solenoid Switch NS | 4-2 | ソレノイドスイッチ6連動 | | |
| SW102 | KA 90 32 20 | Remote Rotary Switch NS | 4-6 | リモートルォタリースイッチ | | |
| * RY101 ~104 | KC 00 12 90 | Relay | HB2E 24V | リレー | | |
| PJ101 | LB 20 19 50 | Pin Jack | 2P | ピンジャック | | |
| * " | LB 20 19 80 | " | 2P | " | | |
| * PJ102 | LB 40 09 70 | " | 4P | " | | |
| " | LB 40 09 30 | " | 4P | " | | |
| PJ103 | LB 60 42 20 | " | 6P | " | | |
| * PJ104 PJ105 | LB 40 09 80 | " | 4P | " | | |
| LA 00 21 10 | Wrapping Terminal i-Type | P=5 2P | i型ラッピング端子板 | | | |
| LA 00 23 20 | " | P=7.5 3P | " | | | |
| LA 00 25 40 | " | P=5(0) 2P | " | | | |
| LA 00 41 20 | Test Point Pin | | テストポイントピン | | | |
| LB 00 30 30 | Socket | 3P | ジャンパーソケット | | | |
| LB 00 30 40 | " | 4P | " | | | |
| * LB 00 30 60 | " | 6P | " | | | |
| * LB 00 30 70 | " | 7P | " | | | |
| * MI 07 05 20 | Cable | ℓ=140 5P | パラレルケーブル | | | |
| LB 90 40 50 | Connector Plug L Type | M34-05-03-134P 5P | コネクタプラグ | | | |
| LB 90 40 60 | " | M34-06-03-134P 6P | " | | | |
| BB 06 97 30 | Shield Plate | | シールド板 | | C-70 | |
| CB 60 78 40 | VCP Cap | VCP-8(Black) | VCPキャップ | | C-70 | |
| BA 07 72 90 | Heat Sink | | 放熱板 | | | |
| EN 33 00 10 | Bind Head Tapping Screw | 3×8 FCM3-Bℓ | 鉄バインドタッピングネジ 2種ミソ | | | |
| BB 06 83 70 | Metal Fitting | | アース金具 | | A-550 | |

* : New Parts (新部品)

| Ref. No. | Part No. | Description | (部 品 名) | Remarks | Common model | Markets |
|-------------------|-------------|----------------------------|-----------------------|---------|--------------|---------|
| ※ | NA 07 84 60 | Tone Control Circuit Board | トーンコントロールシート | | | R |
| ※ | NA 07 84 70 | " | " | | | U, C |
| ※ | NA 07 84 80 | " | " | | | A, G, B |
| C401 C402 | UW 96 64 70 | Electrolytic Capacitor | 4.7 μ F 50V | ケミコン | | |
| C403 C404 | FU 35 11 00 | Mica Capacitor FE | 10pF 500V(J) | マイカコン | | |
| C405 C406 | FG 41 12 20 | Ceramic Capacitor | 22pF 50V(K) | セラコン | | |
| C407 C408 | FT 51 22 20 | Polypropylene Capaeitor NP | 220pF 50V(K) | ポリプロコン | | |
| C409 C410 | FG 41 12 20 | Ceramic Capacitor | 22pF 50V(K) | セラコン | | |
| C411 ~414 | UW 91 74 70 | Electrolytic Capacitor | 47 μ F 6.3V | ケミコン | | |
| C415 C416 | UW 96 71 00 | " | 10 μ F 50V | " | | |
| C417 ~420 | UW 91 74 70 | " | 47 μ F 6.3V | " | | |
| ※ C421 C422 | UA 25 51 50 | Mylar Capacitor | 0.15 μ F 50V(J) | マイラーコン | | |
| C423 C424 | UA 25 31 50 | " | 0.0025 μ F " | " | | |
| C425 C426 | UW 91 74 70 | Electrolytic Capacitor | 47 μ F 6.3V | ケミコン | | |
| ※ C427 C428 | UW 95 73 30 | " | 33 μ F 35V | " | | |
| C429 ~432 | UA 25 51 00 | Mylar Capacitor | 0.1 μ F 50V(J) | マイラーコン | | |
| C433 C434 | FT 51 21 00 | Polypropylene Capacitor NP | 100pF 50V(K) | ポリプロコン | | |
| C439 C440 | FA 15 31 00 | Mylar Capacitor | 0.001 μ F 50V(J) | マイラーコン | | |
| C441 C442 | UA 25 31 00 | " | " | " | | |
| C443 C444 | FU 35 12 70 | Mica Capacitor FE | 27pF 500V(J) | マイカコン | | |
| C445 C446 | FU 35 13 30 | " FE | 33pF " | " | | |
| C447 C448 | UA 25 31 00 | Mylar Capacitor | 0.001 μ F 50V(K) | マイラーコン | | |
| C451 C452 | UW 96 61 00 | Electrolytic Capacitor | 1 μ F 50V | ケミコン | | |
| C453 C454 | FU 35 12 20 | Mica Capacitor FE | 22pF 500V(J) | マイカコン | | |
| ※ C459 C460 | UA 25 31 00 | Mylar Capacitor | 0.001 μ F 50V(J) | マイラーコン | | |
| C461 C462 | UW 86 71 00 | Electrolytic Capacitor | 10 μ F 50V | ケミコン | | |
| ※ C463 | UA 25 31 50 | Mylar Capacitor | 0.0015 μ F 50V(J) | マイラーコン | | |
| C464 | FG 44 41 00 | Ceramic Capacitor | 0.01 μ F 50V(Z) | セラコン | | |
| C465 C466 | UW 91 74 70 | Electrolytic Capacitor | 47 μ F 6.3V | ケミコン | | |
| C467 C468 | FG 41 21 00 | Ceramic Capacitor | 100pF 50V(K) | セラコン | | |
| C469 C470 | FU 35 13 30 | Mica Capacitor FE | 33pF 500V(J) | マイカコン | | |
| C471 C472 | UW 95 82 20 | Electrolytic Capacitor | 220 μ F 35V | ケミコン | | |
| C473 | UW 95 74 70 | " | 47 μ F 35V | " | | |
| C475 | FC 28 41 00 | Polypropylene Capacitor QP | 0.01 μ F 250V(J) | ポリプロコン | | |
| C476 | FG 41 15 60 | Ceramic Capacitor | 56pF 50V(K) | セラコン | | |
| C477 C478 | UW 86 71 00 | Electrolytic Capacitor | 10 μ F 50V | ケミコン | | |
| C479 C480 | UW 96 91 00 | " | 100 μ F 50V | " | | |
| C481 C482 | UA 55 51 00 | Mylar Capacitor | 0.1 μ F 50V(J) | マイラーコン | | |
| C483 ~488 | UW 86 71 00 | Electrolytic Capacitor | 10 μ F 50V | ケミコン | | |
| C489 | UW 95 74 70 | " | 47 μ F 35V | " | | |
| C490 | UW 86 71 00 | " | 10 μ F 50V | " | | |
| C491 | UW 96 71 00 | " | 10 μ F 50V | " | | |
| C492 | FG 44 44 70 | Ceramic Capacitor | 0.047 μ F 50V(Z) | セラコン | | |
| C493 | FG 44 41 00 | " | 0.01 μ F 50V(Z) | " | | |
| ※ C494 | UA 55 54 70 | Mylar Capacitor | 0.47 μ F 50V(J) | マイラーコン | | |
| C497 C498 | FG 44 41 00 | Ceramic Capacitor | 0.01 μ F 50V(Z) | セラコン | | |

※ : New Parts (新部品)

| Ref. No. | Part No. | Description | (部 品 名) | Remarks | Common model | Markets |
|----------------|-------------|---------------------------|-----------------------|------------|--------------|---------|
| R401 R402 | HJ 35 81 00 | Carbon Resistor | 100K Ω RD25 | カーボン抵抗 | | |
| R403 R404 | HJ 35 85 60 | " | 560K Ω " | " | | |
| R405 -408 | HJ 35 71 50 | " | 15K Ω " | " | | |
| R409 R410 | HJ 35 61 00 | " | 1K Ω " | " | | |
| R411 -414 | HJ 35 71 50 | " | 15K Ω " | " | | |
| R415 R416 | HJ 35 52 20 | " | 220 Ω " | " | | |
| R417 R418 | HJ 35 81 00 | " | 100K Ω " | " | | |
| R419 -426 | HJ 35 66 80 | " | 6.8K Ω " | " | | |
| R427 R428 | HJ 35 91 00 | " | 1M Ω " | " | | |
| R429 R430 | HJ 35 73 30 | " | 33K Ω " | " | | |
| R431 R432 | HJ 35 76 80 | " | 68K Ω " | " | | |
| R433 R434 | HJ 35 51 00 | " | 100 Ω " | " | | |
| R435 R436 | HJ 35 81 50 | " | 150K Ω " | " | | |
| R439 R440 | HZ 00 25 10 | Metal Film Resistor | 1.5K Ω SN14K2E | 金属被膜抵抗 | | |
| R443 -446 | HU 57 52 20 | " | 220 Ω " | " | | |
| R447 R448 | HJ 35 54 70 | Carbon Resistor | 470 Ω RD25 | カーボン抵抗 | | |
| * R449 R450 | HL 71 58 20 | Metal Oxide Film Resistor | 820 Ω 1P | 酸化抵抗フォーミング | | |
| R453 R454 | HJ 35 71 80 | " | 18K Ω " | " | | |
| R455 R456 | HJ 35 73 90 | " | 39K Ω " | " | | |
| R457 R458 | HJ 35 63 30 | " | 3.3K Ω " | " | | |
| R459 R460 | HJ 35 71 00 | " | 10K Ω " | " | | |
| R461 R462 | HJ 35 63 30 | Carbon Resistor | 3.3K Ω RD25 | カーボン抵抗 | | |
| * R463 R464 | HL 71 63 90 | Metal Oxide Film Resistor | 3.9K Ω 1P | 酸化抵抗フォーミング | | |
| R465 R466 | HJ 35 52 20 | Carbon Resistor | 220 Ω RD25 | カーボン抵抗 | | |
| R467 -470 | HU 57 54 70 | Metal Film Resistor | 470 Ω SN14K2E | 金属被膜抵抗 | | |
| R471 -474 | HJ 35 51 80 | Carbon Resistor | 180 Ω RD25 | カーボン抵抗 | | |
| R475 -478 | HJ 35 45 60 | " | 56 Ω " | " | | |
| R479 -482 | HJ 35 52 20 | " | 220 Ω " | " | | |
| R487 R488 | HJ 35 44 70 | Carbon Resistor | 47 Ω RD25 | カーボン抵抗 | | |
| R493 R494 | HJ 35 71 00 | " | 10K Ω " | " | | |
| R495 R496 | HJ 35 72 20 | " | 22K Ω " | " | | |
| R497 R498 | HJ 35 51 00 | " | 100 Ω " | " | | |
| R499 R500 | HJ 35 71 00 | " | 10K Ω " | " | | |
| * R501 | HL 83 56 80 | Metal Oxide Film Resistor | 680 Ω 3P | 酸化抵抗ストレート | | |
| R502 -504 | HJ 35 81 00 | Carbon Resistor | 100K Ω RD25 | カーボン抵抗 | | |
| R505 R506 | HJ 35 61 00 | " | 1K Ω " | " | | |
| R507 R508 | HJ 35 64 70 | " | 4.7K Ω " | " | | |
| R509 R510 | HJ 35 54 70 | " | 470 Ω " | " | | |
| R511 R512 | HJ 35 66 80 | " | 6.8K Ω " | " | | |
| R513 -516 | HJ 35 42 20 | " | 22 Ω " | " | | |
| * R517 R518 | HL 72 46 80 | Metal Oxide Film Resistor | 68 Ω 2P | 酸化抵抗フォーミング | | |
| R519 R529 | HL 72 53 30 | " | 330 Ω 2P | " | | |
| R521 R522 | HJ 35 61 80 | Carbon Resistor | 1.8K Ω RD25 | カーボン抵抗 | | |
| R523 R524 | HJ 35 61 00 | " | 1K Ω " | " | | |
| * R525 | HL 72 62 20 | Metal Oxide Film Resistor | 2.2K Ω 2P | 酸化抵抗フォーミング | | |
| R528 R529 | HJ 35 52 20 | Carbon Resistor | 220 Ω RD25 | カーボン抵抗 | | |
| R530 | HJ 35 64 70 | " | 4.7K Ω " | " | | |

* : New Parts (新部品)

| Ref. No. | Part No. | Description | (部 品 名) | Remarks | Common model | Markets |
|------------------|-------------|-----------------------------|----------------------------|------------|--------------------------------|---------|
| R531 | HJ 35 72 70 | Carbon Resistor | 27K Ω RD25 | カーボン抵抗 | | |
| R532 | HJ 35 63 90 | " | 3.9K Ω " | " | | |
| R533 | HJ 35 61 50 | " | 1.5K Ω " | " | | |
| R534 | HJ 35 62 70 | " | 2.7K Ω " | " | | |
| R535 | HJ 35 72 20 | " | 22K Ω " | " | | |
| R536 | HJ 35 66 80 | " | 6.8K Ω " | " | | |
| R537 | HJ 35 72 70 | " | 27K Ω " | " | | |
| R538 R539 | HJ 35 64 70 | " | 4.7K Ω " | " | | |
| R540 | HV 35 44 70 | Flame Proof Carbon Resistor | 47 Ω RDF25SF | 不燃化カーボン抵抗 | | |
| R541 | HJ 35 84 70 | Carbon Resistor | 470K Ω RD25 | カーボン抵抗 | | |
| R542 R543 | HJ 35 51 00 | " | 100 Ω " | " | | |
| R545 | HJ 35 82 70 | " | 270K Ω " | " | | |
| R546 | HJ 35 63 30 | " | 3.3K Ω " | " | | |
| ※ R547 | HL 83 55 60 | Metal Oxide Film Resistor | 560 Ω 3P | 酸化抵抗ストレート | | |
| | | | | | | |
| | | | | | | |
| | | | | | | |
| R553 R554 | HJ 35 53 30 | Carbon Resistor | 330 Ω RD25 | カーボン抵抗 | | |
| R555 R556 | HJ 35 68 20 | " | 8.2K Ω " | " | | |
| R557 R558 | HJ 35 51 00 | " | 100 Ω " | " | | |
| R559 R560 | HJ 35 74 70 | " | 47K Ω " | " | | |
| R561 R562 | HJ 35 68 20 | " | 8.2K Ω " | " | | |
| R563 R564 | HJ 35 73 30 | Carbon Resistor | 33K Ω RD25 | カーボン抵抗 | | |
| ※ FR401 FR402 | HW 59 48 20 | Fuse Resistor | 82 Ω 1/4W | ヒューズ抵抗 | | |
| ※ VR401 VR402 | HS 41 15 80 | Variable Resistor CT,CC | 200K Ω 特 \times 2 | 可変抵抗 | | |
| ※ VR403 VR404 | HS 41 15 90 | " | 30K Ω 特 \times 2 | " | | |
| VR405 VR406 | HY 00 10 30 | Semi Variable Resistor | TM8KV2-15 B5K Ω | 半固定抵抗 | | |
| TR401 TR402 | iC 22 91 10 | Dual Transistor | 2SC2291(F,G) | デュアルトランジスタ | | |
| TR405 TR406 | iE 10 19 10 | Dual FET | μ PA68H(L,M) | デュアルFET | | |
| TR407 TR408 | iZ 00 02 00 | Twin Transistor | 2SC1815(O,Y) | ツイントランジスタ | | |
| TR409 TR410 | iZ 00 01 30 | Dual Transistor | μ PA75V | デュアルトランジスタ | | |
| TR411 TR412 | iZ 00 02 00 | Twin Transistor | 2SC1815(O,Y) | ツイントランジスタ | | |
| TR413 ~ 416 | iA 06 73 10 | Transistor | 2SA673A(C,D) | トランジスタ | } Inter- changeable (併用) | |
| " | iA 10 15 30 | " | 2SA1015(Y,GR) | " | | |
| TR417 TR418 | iC 17 40 00 | " | 2SC1740(R,S) | " | } Inter- changeable (併用) | |
| " | iC 23 20 10 | " | 2SC2320(E,F) | " | | |
| ※ " | iC 26 34 00 | " | 2SC2634(R,S,T) | " | | |
| TR419 TR420 | iA 09 99 10 | " | 2SA999(E,F) | " | } Inter- changeable (併用) | |
| " | iA 09 33 00 | " | 2SA933(Q,R) | " | | |
| ※ " | iA 11 27 00 | " | 2SA1127(R,S,T) | " | | |
| TR423 TR424 | iC 27 05 00 | " | 2SC2075(O,Y) | " | | |
| TR425 TR426 | iA 11 45 00 | " | 2SA1145(O,Y) | " | | |

※ : New Parts (新部品)

| Ref. No. | Part No. | Description | (部 品 名) | Remarks | Common model | Markets |
|------------------|-------------|--------------------|----------------|------------|----------------------------|---------|
| TR431 TR432 | iC 04:60:80 | Transistor | 2SC460(B,C) | トランジスタ | | |
| TR433 TR434 | iD 04:38:10 | " | 2SD438(E,F) | " | | |
| TR435 TR436 | iB 05:60:10 | " | 2SB560(E,F) | " | | |
| ※ TR437 | iC 09:82:00 | " | 2SC982 | " | | |
| | | | | | | |
| | | | | | | |
| ※ TR438 TR439 | iE 10:26:10 | FET | 2SK246(Y) | FET | | |
| ※ TR440 | iD 08:80:10 | Transistor | 2SD880(Y,GR) | トランジスタ | } Inter-changeable (併用) | |
| ※ " | iD 03:13:00 | " | 2SD313(E,F) | " | | |
| TR441 | iC 12:13:30 | " | 2SC1213A(C,D) | " | } Inter-changeable (併用) | |
| " | iC 18:15:80 | " | 2SC1815(Y,GR) | " | | |
| TR442 | iA 06:73:10 | " | 2SA673A(C,D) | " | } Inter-changeable (併用) | |
| " | iA 10:15:30 | " | 2SA1015(Y,GR) | " | | |
| ※ TR443 | iD 08:80:10 | " | 2SD880(Y,GR) | " | } Inter-changeable (併用) | |
| ※ " | iD 03:13:00 | " | 2SD313(E,F) | " | | |
| TR444 TR445 | iC 17:40:00 | " | 2SC1740(R,S) | " | } Inter-changeable (併用) | |
| " | iC 18:15:80 | " | 2SC1815(Y,GR) | " | | |
| TR446 | iA 09:99:10 | " | 2SA999(E,F) | " | } Inter-changeable (併用) | |
| " | iA 09:33:00 | " | 2SA933(Q,R) | " | | |
| ※ " | iA 11:27:00 | " | 2SA1127(R,S,T) | " | | |
| ※ TR447 | iD 06:00:00 | " | 2SD600(E,F) | " | | |
| TR448 | iB 06:31:00 | " | 2SB631(E,F) | " | | |
| | | | | | | |
| D401 D402 | iF 00:00:40 | Diode | IS1555 | ダイオード | } Inter-changeable (併用) | |
| " | iF 00:06:70 | " | IS2473 | " | | |
| D403 D404 | iF 00:15:10 | Zener Diode | HZ-6CIL | ツェナーダイオード | | |
| D407 D408 | iF 00:00:40 | Diode | IS1555 | ダイオード | } Inter-changeable (併用) | |
| " | iF 00:06:70 | " | IS2473 | " | | |
| D409 D410 | iF 00:07:90 | Varistor Diode | MV12 | バリスタ | | |
| D411 ~412 | iF 00:15:10 | Zener Diode | HZ-6CIL | ツェナーダイオード | | |
| D417 D418 | iF 00:07:90 | Variator Diode | MV12 | バリスタ | | |
| D419 | iH 00:07:70 | Diode, Bridge | SIRBA | ダイオード、ブリッジ | | |
| D420 D421 | iF 00:16:20 | Diode | IS2076A | ダイオード | } Inter-changeable (併用) | |
| " | iH 00:07:10 | " | WO6C | " | | |
| D422 ~424 | iF 00:00:40 | " | IS1555 | " | } Inter-changeable (併用) | |
| " | iF 00:06:70 | " | IS2473 | " | | |
| D425 | iF 00:15:10 | Zener Diode | HZ-6CIL | ツェナーダイオード | | |
| D426 D427 | iF 00:20:80 | " | HZ16L-3 | " | | |
| D428 | iF 00:25:00 | " | HZ-16-2 | " | | |
| D429 | iF 00:00:40 | Diode | IS1555 | ダイオード | } Inter-changeable (併用) | |
| " | iF 00:06:70 | " | IS2473 | " | | |
| | | | | | | |
| ※ IC401 IC402 | iG 04:00:00 | IC | NJM4560 | IC | | |
| ※ IC403 IC404 | iG 05:82:00 | " | M5218L | " | | |
| IC405 | iG 04:00:00 | " | NJM4560 | " | | |
| | | | | | | |
| ※ SW401 | KA 80:28:20 | Push Switch SUN NS | 2-2 | プッシュスイッチ | | |
| ※ SW402 SW403 | KA 80:28:30 | " | 4-2 | " | | |
| F401 | KB 00:02:10 | Fuse | T1.0A 125V | ヒューズタイラッシュ | | J |
| " | KB 00:03:10 | " | T0.5A 250V | " | | A |
| " | KB 00:03:30 | " | T1.0A 250V | " | | R |

※ : New Parts (新部品)

| Ref. No. | Part No. | Description | (部 品 名) | Remarks | Common model | Markets |
|---------------|-------------|-------------------------|---------------|---------------------|--------------|--------------|
| F401 | KB:00:12:20 | Fuse UL ST-4 | 750mA 250V | ヒューズ | | U, C |
| " | KB:00:06:40 | Fuse (S) | T250mA 250V | ヒューズ(S)タイムラグ | | G, B |
| F402 | KB:00:03:10 | Fuse | T0.5A 250V | ヒューズタイラッシュ | | R |
| * RY401 | KC:00:12:90 | Relay | HB2E 24V | リレー | | |
| * PJ401 | LB:20:19:80 | Pin Jack | 2P | ピンジャック | | J |
| " | LB:20:19:50 | " | 2P | " | | R,U,C,G,A,B, |
| JK401 | LB:30:15:20 | Headphone Jack | | ヘッドホンジャック(黒) | | |
| | LA:00:20:00 | Wrapping Terminal | P=7.5 2P | i型ラッピング端子板 | | |
| | LA:00:21:40 | " | P=10 2P | " | | |
| | LA:00:23:20 | " | P=7.5 3P | " | | |
| | LA:00:25:40 | " | P=5(0) 2P | " | | |
| | LA:00:25:60 | " | P=7.5(0) 2P | " | | |
| | LB:00:30:30 | | 3P | ジャンパーソケット | | |
| * LB:20:19:70 | | Fuse Holder Pin | 23165081 | ヒューズホルダーピン | | |
| | LB:20:10:60 | " | YSH403T | " | | |
| * Mi:07:00:00 | | Cable | ℓ=120 2P | バラレルケーブル | | |
| CB:06:92:50 | | Binding Tie | BK-1 | インシュロックタイ | | |
| * Mi:07:01:70 | | Cable | ℓ=120 3P | バラレルケーブル | | |
| BA:08:24:20 | | Heat Sink | | 放熱板 | C-70 | |
| BB:06:62:90 | | Washer | | アースワッシャー | | |
| BB:06:83:70 | | Metal Fitting | | アース金具 | | |
| EN:33:00:10 | | Bind Head Tapping Screw | 3×8(FCM3-Bℓ) | 鉄バインドタッピンネジ 2種ミソ | | |
| ED:82:61:00 | | Bind Head Screw | M2.6×10 | 銅バインド小ネジ | A1060 | |
| * EV:30:32:60 | | Spring Washer | M2.6(FCM3-Bℓ) | スプリングワッシャー | | |
| EV:20:32:60 | | Flat Washer | M2.6(FCM3-Bℓ) | 平ワッシャーミガキ 外径φ6.5 | | |

* : New Parts (新部品)