

# MINI COMPONENT SYSTEM CRX-E500

# CDC-E500

## SERVICE MANUAL

The CRX-E500 is composed of the RX-E400 and the CDC-E500.

This service manual is for the CDC-E500.

For the RX-E400 service manual, please refer to the following publication number:

RX-E400      100809

For the system operation, please refer to the service manual for the RX-E400.

### IMPORTANT NOTICE

This manual has been provided for the use of authorized YAMAHA Retailers and their service personnel.

It has been assumed that basic service procedures inherent to the industry, and more specifically YAMAHA Products, are already known and understood by the users, and have therefore not been restated.

**WARNING:** Failure to follow appropriate service and safety procedures when servicing this product may result in personal injury, destruction of expensive components, and failure of the product to perform as specified. For these reasons, we advise all YAMAHA product owners that any service required should be performed by an authorized YAMAHA Retailer or the appointed service representative.

**IMPORTANT:** The presentation or sale of this manual to any individual or firm does not constitute authorization, certification or recognition of any applicable technical capabilities, or establish a principle-agent relationship of any form.

The data provided is believed to be accurate and applicable to the unit(s) indicated on the cover. The research, engineering, and service departments of YAMAHA are continually striving to improve YAMAHA products. Modifications are, therefore, inevitable and specifications are subject to change without notice or obligation to retrofit. Should any discrepancy appear to exist, please contact the distributor's Service Division.

**WARNING:** Static discharges can destroy expensive components. Discharge any static electricity your body may have accumulated by grounding yourself to the ground buss in the unit (heavy gauge black wires connect to this buss).

**IMPORTANT:** Turn the unit OFF during disassembly and part replacement. Recheck all work before you apply power to the unit.

## ■ CONTENTS

TO SERVICE PERSONNEL .....	2~3	TEST MODE .....	24~25
PREVENTION OF ELECTRO STATIC DISCHARGE ...	3	TROUBLESHOOTING .....	26
FRONT PANEL .....	4	IC DATA .....	27~32
REMOTE CONTROL PANEL .....	4	DISPLAY DATA .....	33
REAR PANELS .....	5	REMOTE CONTROL .....	33
SPECIFICATIONS .....	6	BLOCK DIAGRAM .....	34
INTERNAL VIEW .....	6	PRINTED CIRCUIT BOARD .....	35~37
DISASSEMBLY PROCEDURES .....	7	IC BLOCK .....	38
MAIN P.C.B. OPERATION CHECK .....	8	PIN CONNECTION DIAGRAM .....	38
CDC-MECHANISM REPAIRING PROCEDURES ...	9~19	SCHEMATIC DIAGRAM .....	39
STANDARD OPERATION CHART .....	20~23	PARTS LIST .....	41~48



このサービスマニュアルは、エコマーク認定の再生紙を使用しています。  
This Service Manual uses recycled paper.

100810

Copyright 2002 YAMAHA CORPORATION □  
This manual is copyrighted by YAMAHA and may not be copied or □  
redistributed either in print or electronically without permission. □



**YAMAHA**  
YAMAHA CORPORATION  
P.O.Box 1, Hamamatsu, Japan

CDC-E500

## ■ TO SERVICE PERSONNEL

### 1. Critical Components Information

Components having special characteristics are marked  and must be replaced with parts having specifications equal to those originally installed.

### 2. Leakage Current Measurement (For 120V Models Only)

When service has been completed, it is imperative to verify that all exposed conductive surfaces are properly insulated from supply circuits.

- Meter impedance should be equivalent to 1500 ohm shunted by 0.15 $\mu$ F.
- Leakage current must not exceed 0.5mA.
- Be sure to test for leakage with the AC plug in both polarities.

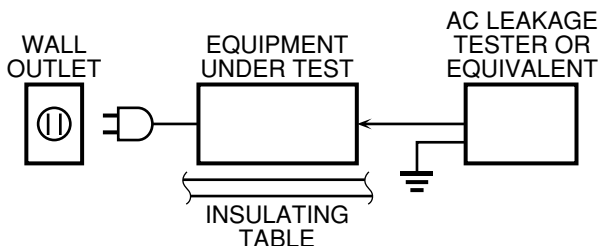

THE COMPACT DISC PLAYER SHOULD NOT BE ADJUSTED OR REPAIRED BY ANYONE EXCEPT PROPERLY QUALIFIED SERVICE PERSONNEL.

## WARNING: CHEMICAL CONTENT NOTICE!

The solder used in the production of this product contains LEAD. In addition, other electrical/electronic and/or plastic (where applicable) components may also contain traces of chemicals found by the California Health and Welfare Agency (and possibly other entities) to cause cancer and/or birth defects or other reproductive harm.

DO NOT PLACE SOLDER, ELECTRICAL/ELECTRONIC OR PLASTIC COMPONENTS IN YOUR MOUTH FOR ANY REASON WHATSOEVER!

Avoid prolonged, unprotected contact between solder and your skin! When soldering, do not inhale solder fumes or expose eyes to solder/flux vapor!

If you come in contact with solder or components located inside the enclosure of this product, wash your hands before handling food.

## WARNING: Laser Safety

This product contains a laser beam component. This component may emit invisible, as well as visible radiation, which may cause eye damage. To protect your eyes and skin from laser radiation, the following precautions must be used during servicing of the unit.

- 1) When testing and/or repairing any component within the product, keep your eyes and skin more than 30 cm away from the laser pick-up unit at all times. Do not stare at the laser beam at any time.
- 2) Do not attempt to readjust, disassemble or repair the laser pick-up, unless noted elsewhere in this manual.
- 3) CAUTION: Use of controls, adjustments or performance of procedures other than those specified herein may result in hazardous radiation exposure.

## Laser Emitting conditions:

- 1) When the Top Cover is removed, and the STANDBY/ON key is turned to the "ON" position, the laser component will emit a beam for several seconds to detect if a disc is present. During this time (5 - 10 sec.) the laser may radiate through the lens of the laser pick-up unit. Do not attempt any servicing during this period!  
If no disc is detected, the laser will stop emitting the beam. When a disc is loaded, you will not be exposed to any laser emissions.
- 2) The laser power level can be adjusted with the VR on pick-up PWB. However, this level has been set by the factory prior to shipping from the factory. Do not adjust this laser level control unless instruction is provided elsewhere in this manual. Adjustment of this control can increase the laser emission level from the device.

## PROTECTION OF EYES FROM LASER BEAM DURING SERVICING

This set employs a laser. Therefore, be sure to carefully follow the instructions below when servicing.

### 1. Laser Diode Properties

- Material : GaAlAs
- Wavelength : 780 nm
- Emission Duration : Continuous
- Laser Output : max. 44.6  $\mu$ W\*

\* This output is the value measured at a distance of about 200 mm from the objective lens surface on the Optical Pick-up Block.

### 2. When checking the laser diode emission, keep your eyes more than 30 cm away from the objective lens.

VARO!: AVATTAESSA JA SUOJALUKITUS OHITETTAESSA OLET ALTTIINA NÄKYMÄTTÖMÄLLE LASER-SÄTEILYLLE. ÄLÄ KATSO SÄTEESEEN.

WARNING!: OSYNLIG LASERSTRÅLNING NÄR DENNA DEL ÄR ÖPPNAD OCH SPÄRREN ÄR URKOPPLAD. BETRAKTA EJ STRÅLEN.

## ■ PREVENTION OF ELECTRO STATIC DISCHARGE

Some semiconductor (solid state) devices can be damaged easily by static electricity. Such components commonly are called Electrostatically Sensitive (ES) Devices. Examples of typical ES devices are integrated circuits and some field-effect transistors and semiconductor "chip" components. The following techniques should be used to help reduce the incidence of component damage caused by electro static discharge (ESD).

1. Immediately before handling any semiconductor component or semiconductor-equipped assembly, drain off any ESD on your body by touching a known earth ground. Alternatively, obtain and wear a commercially available discharging ESD wrist strap, which should be removed for potential shock reasons prior to applying power to the unit under test.
2. After removing an electrical assembly equipped with ES devices, place the assembly on a conductive surface such as aluminum foil, to prevent electrostatic charge buildup or exposure of the assembly.
3. Use only a grounded-tip soldering iron to solder or unsolder ES devices.
4. Use only an anti-static solder removal device. Some solder removal devices not classified as "anti-static (ESD protected)" can generate electrical charge sufficient to damage ES devices.
5. Do not use freon-propelled chemicals. These can generate electrical charges sufficient to damage ES devices.
6. Do not remove a replacement ES device from its protective package until immediately before you are ready to install it. (Most replacement ES devices are packaged with leads electrically shorted together by conductive foam, aluminum foil or comparable conductive material).
7. Immediately before removing the protective material from the leads of a replacement ES device, touch the protective material to the chassis or circuit assembly into which the device will be installed.

CAUTION: Be sure no power is applied to the chassis or circuit, and observe all other safety precautions.

8. Minimize bodily motions when handling unpackaged replacement ES devices. (Otherwise harmless motion such as the brushing together of your clothes fabric or the lifting of your foot from a carpeted floor can generate static electricity (ESD) sufficient to damage an ES device).

### Grounding for electrostatic breakdown prevention

#### 1. Human body grounding.

Use the anti static wrist strap to discharge the static electricity from your body.

#### 2. Work table grounding.

Put a conductive material (sheet) or steel sheet on the area where the optical pickup is placed and ground the sheet.

#### Caution:

The static electricity of your clothes will not be grounded through the wrist strap. So take care not to let your clothes touch the optical pickup.

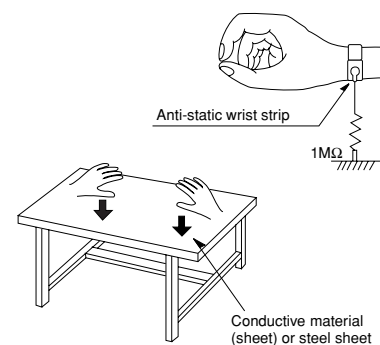

## FRONT PANEL

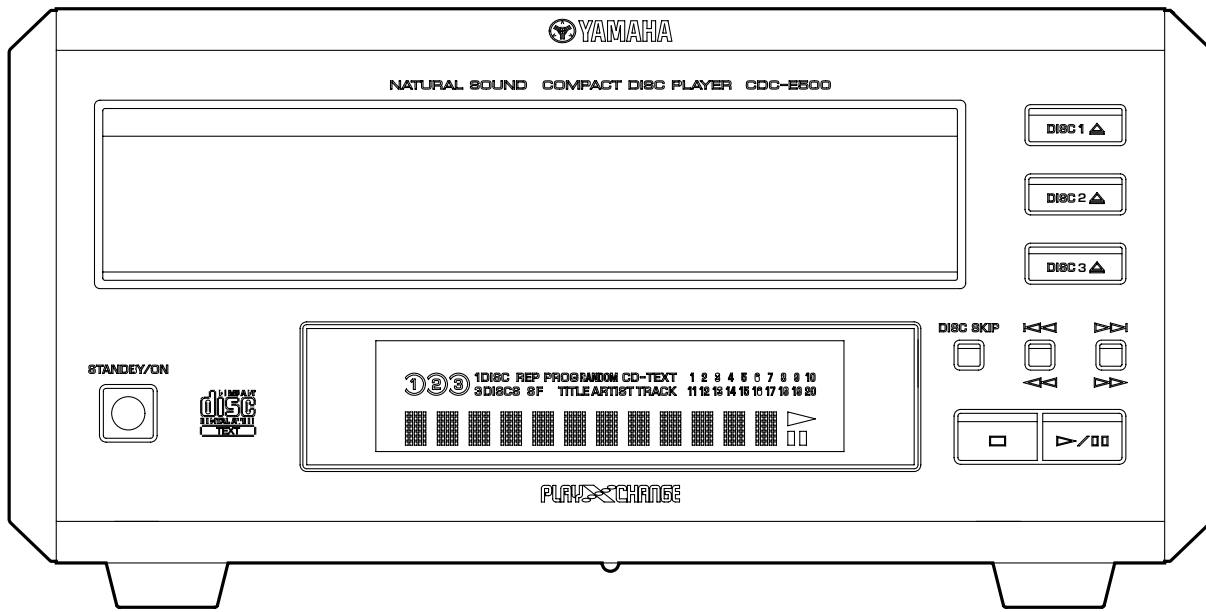

## REMOTE CONTROL PANEL

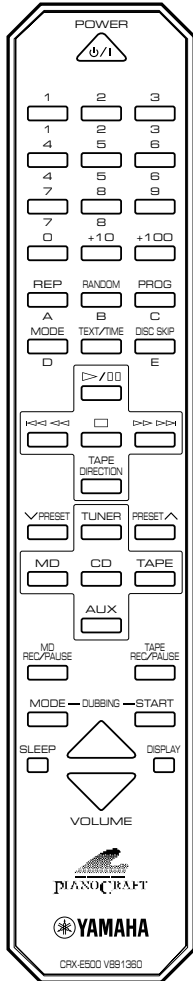

Note: When confirming remote control operation, connect the unit to the RX-E400 by using the system cable.

## REAR PANELS

### U, C models

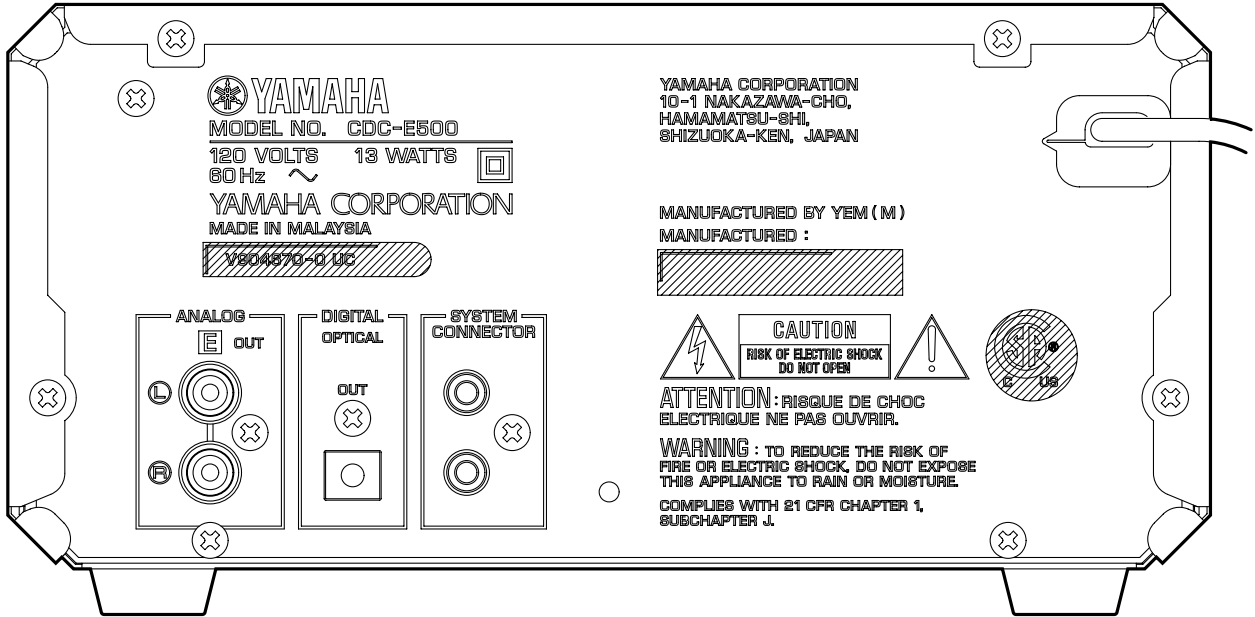

### A model

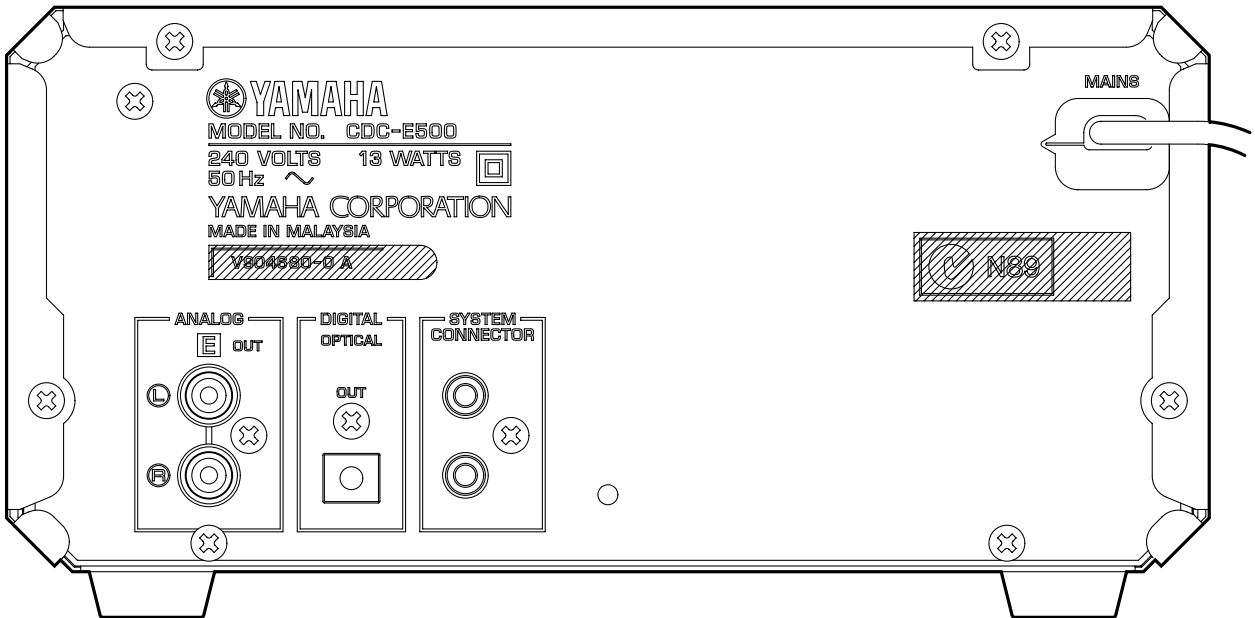

## ■ SPECIFICATIONS

<b>Output Level</b> 1 kHz, 0dB	2 ± 0.5 Vrms
<b>Signal to Noise Ratio (EIAJ)</b>	102 dB or more
<b>Dynamic Range</b>	95 dB or more
<b>Harmonic Distortion + Noise</b> 1 kHz	0.004 % or less
<b>Frequency Response</b> 2 Hz to 20 kHz	0 ± 0.5 dB
<b>Power Supply</b> [U, C models]	AC 120 V, 60 Hz
[A model]	AC 240 V, 50 Hz
<b>Power Consumption</b> [All models]	13 W
<b>Dimensions (W x H x D)</b>	217 x 108 x 346.5 mm (8-9/16" x 4-1/4" x 13-5/8")
<b>Weight</b>	3.5 kg (7lbs. 11oz.)
<b>Finish</b> Gold Color	U, C, A models
Silver Color	U model

### Accessories of CRX-E500

Remote Control x 1, Indoor FM antenna x 1, AM loop antenna x 1, Audio Pin Cable (2P, 1.0m) x 1, System Control Cable (1P, 1.0m) x 1, Battery (size "UM-3", "R6") x 2

\* Specifications are subject to change without notice due to product improvements.

U ..... U.S.A. model      C ..... Canadian model  
A ..... Australian model

## • DIMENSIONS

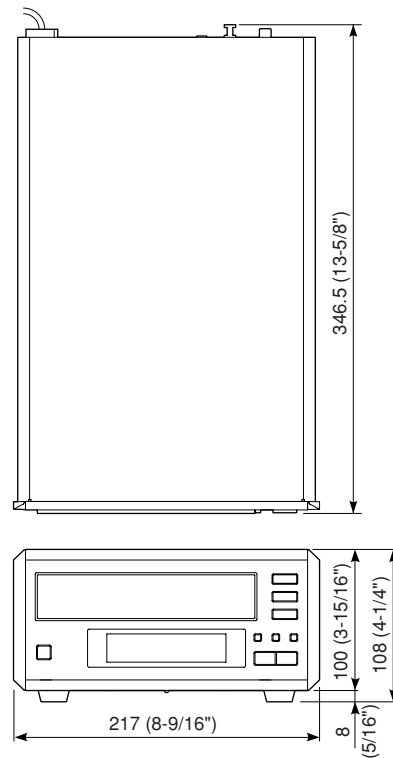

Unit : mm (inch)

## ■ INTERNAL VIEW

- ① MAIN (3) P.C.B.
- ② MAIN (2) P.C.B.
- ③ MAIN (1) P.C.B.
- ④ CDC-MECHANISM UNIT
- ⑤ MAIN (5) P.C.B.

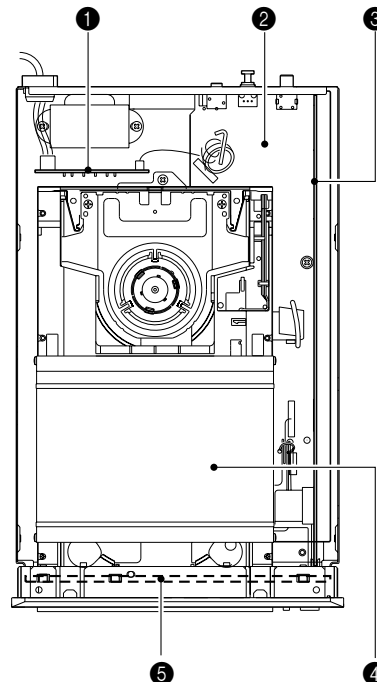

## ■ DISASSEMBLY PROCEDURES

(Remove parts in the order as numbered.)  
 Disconnect the power plug from the AC outlet.

### 1. Removal of Top Cover

- a. Remove 4 screws (①) and 4 screws (②) in Fig. 1.
- b. Lift the Top Cover at the rear and move it rear-ward slantingly.

### 2. Removal of Front Panel Unit

- a. Disconnect cable from Connector (CB200) in Fig. 2.
- b. Remove 2 screws (③) and 2 screws (④) in Fig. 1.
- c. Remove the Front Panel Unit forward in Fig. 1.

### 3. Removal of CDC Mechanism Unit

- a. Remove 1 screw (⑤) and 5 screws (⑥) in Fig. 3 and then remove the CDC Mechanism Unit in Fig. 3.
- b. Disconnect cables from Connectors (CB1, CB2, CB3 and CB4) in Fig. 2.

\* When installing the CDC Mechanism Unit, make sure that its tip end has fitted into the cut in the main chassis securely (confirmed by a clicking sound) before tightening the screw. This is to prevent it from getting loose.

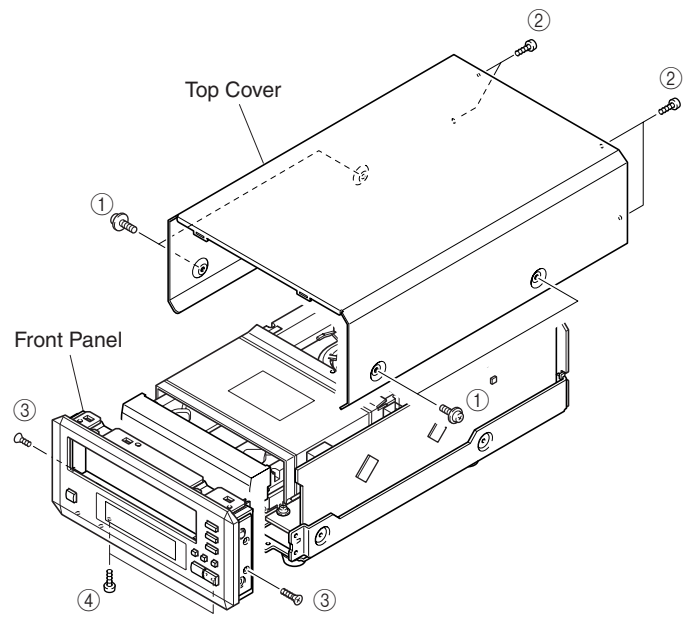

Fig. 1

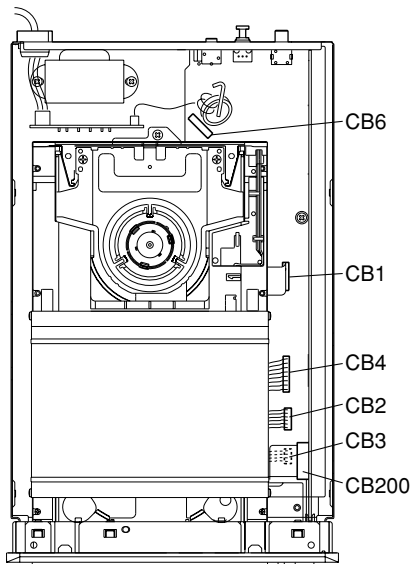

Fig. 2

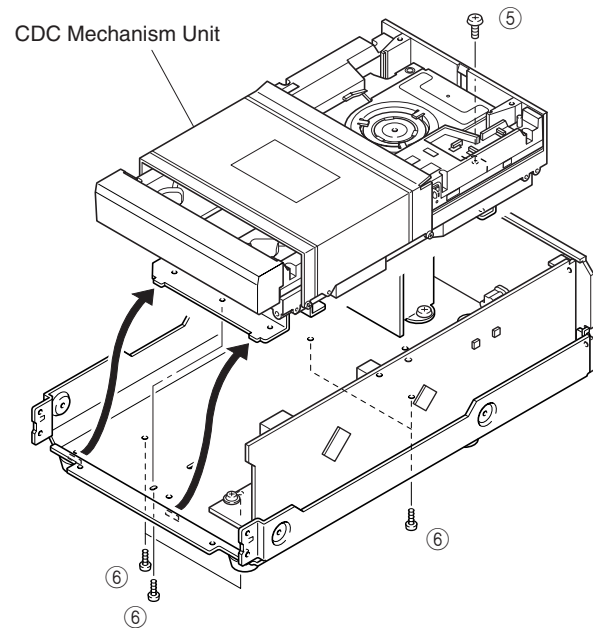

Fig. 3

### The way to open the drawer

- a. Move the lever under the left side face of the mechanism toward the front side first and then toward the rear side. The drawer is unlocked and opens by about 5 to 10cm. (Fig. 4)

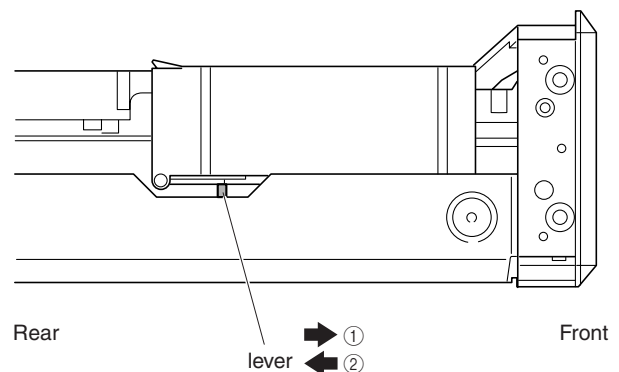
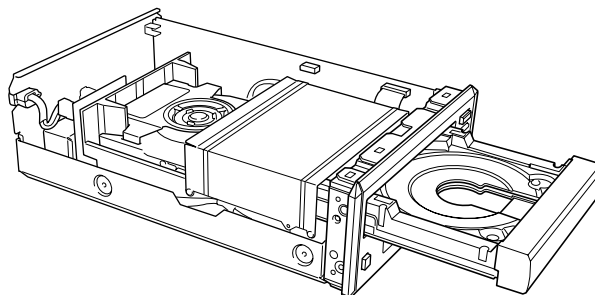

Fig. 4

b. Pull out the drawer to open it fully. (Fig. 5)



**Fig. 5**  
**(Drawer opened fully)**

## ■ MAIN P.C.B. OPERATION CHECK

1. Remove the CDC Mechanism Unit.
2. Disconnect cable from Connector (CB6) in Fig. 2.  
At this time, unwind this cable wound around the ferrite core.
3. Remove 4 screws fixing the MAIN (2) P.C.B. to the chassis.  
Remove 4 screws fixing the MAIN (1) P.C.B. to the rear panel.
4. Remove the MAIN (1) P.C.B. and the MAIN (2) P.C.B. together.
5. Place the MAIN (1) P.C.B. and the MAIN (2) P.C.B. on the blocks.
6. Reinstall the CDC Mechanism Unit.
7. Using extension cables, make connections.
  - ① Bancard : 16P 420mm (V6565800)
  - ② C & C assembly set : 4P 450mm and 8P 450mm (AAX28730)
8. Using a lead wire, connect the grounding of the pin jack (PJ1) and the system connector (JK1) to the rear panel.  
(If it is left unconnected, the grounding floats and the unit may fail to function properly.)

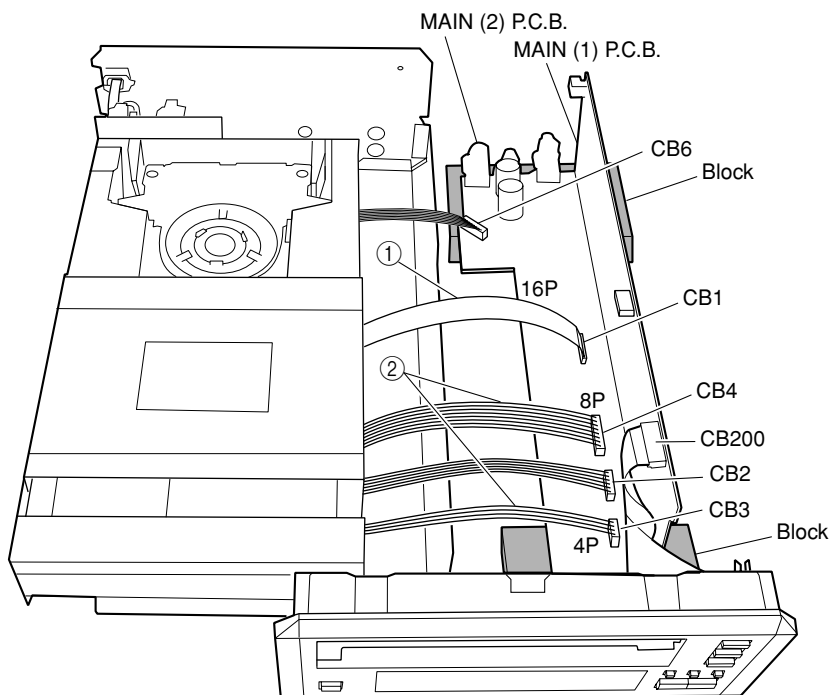



## ■ CDC-MECHANISM REPAIRING PROCEDURES

### 1. Explanation of part names and terms.

Front/rear: With the mechanism installed normally, the drawer opening direction is to the front.

Top/bottom: With the mechanism installed normally, the drawer is visible from the top.

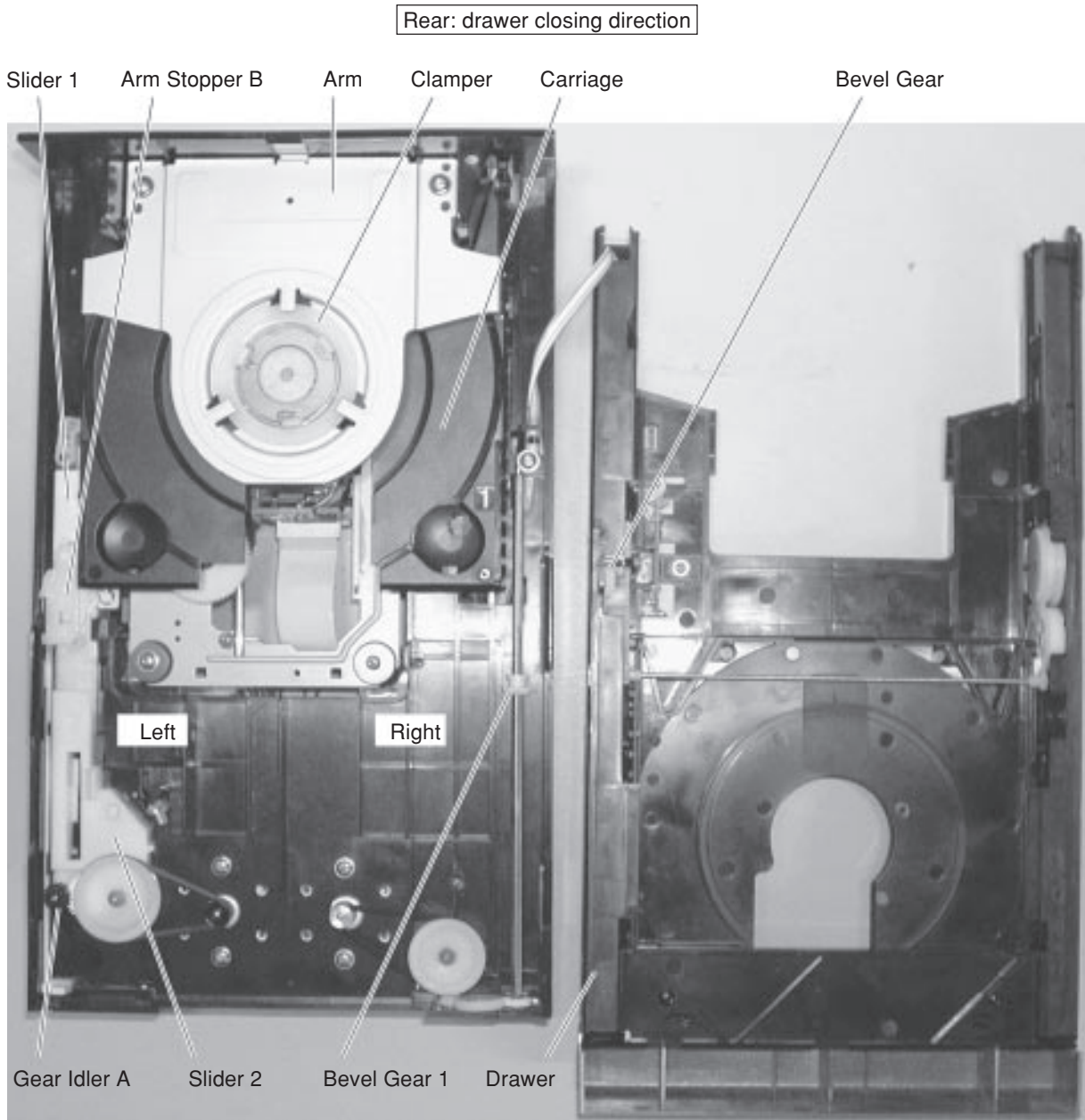

Photo 1

## 2. Opening of Drawer

- a. Move the lever under the left side face of the mechanism toward the front side first and then toward the rear side.  
The drawer is unlocked and opens by about 5 to 10cm. (Photo 2)

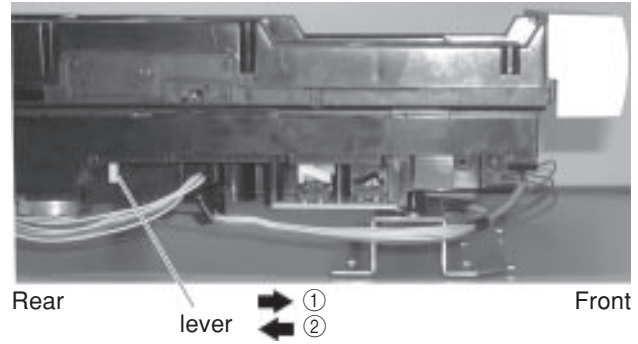

Photo 2

- b. Pull out the drawer to open it fully. (Photo 3)

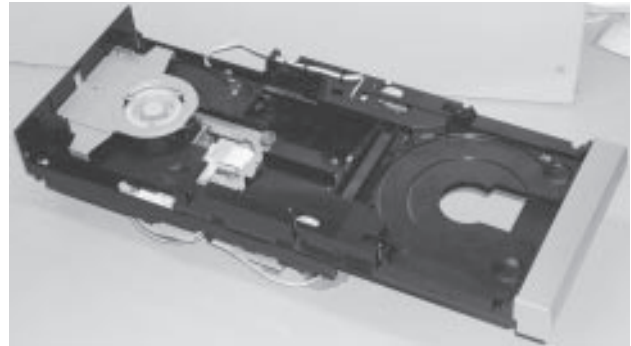
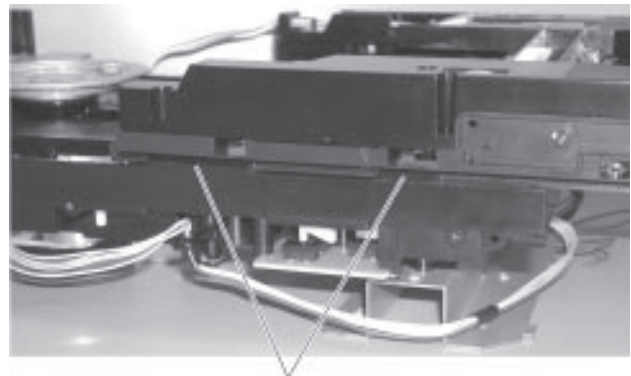

Photo 3  
(Drawer opened fully)

## 3. Removal of Drawer

- a. Open the drawer as described in Procedure 2 above.  
The drawer can be removed without being opened but its removal would be easier if it is open because there would be one less claw locking the drawer.
- b. While holding the rear of the drawer by one hand, push each claw section outward and remove the drawer.  
Also, the drawer can be removed by lifting it up while pushing it inward of the mechanism.  
As there are two claws each on the right and left, repeat the above procedure on both sides. (Photos 4 and 5)
- c. Turn over the removed drawer and place it on the right side of the chassis. (As the drawer is connected to the chassis with a lead wire, it cannot be separated completely.)



Claws on the left side

Photo 4

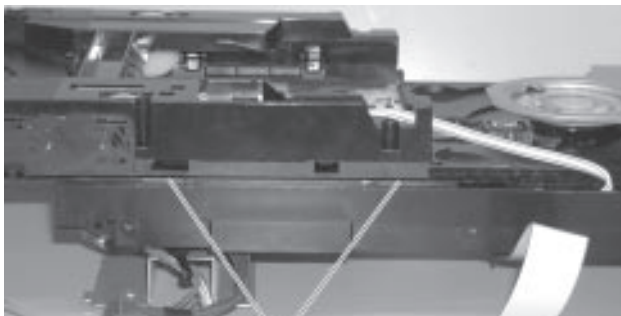

Claws on the right side

Photo 5

#### 4. Removal of Carriage

- a. Turn over the drawer removed as described in Procedures 2 and 3 on page 10 and place it with its front facing toward you. (Photo 6)
- b. Check that the bevel gear located on the left side of the drawer is attached to the drawer. If not, attach it properly. (Photo 6)

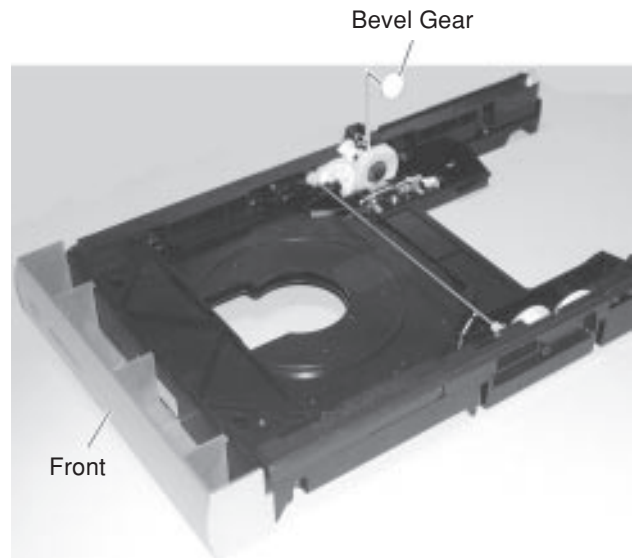

Photo 6

- c. Apply your left thumb to the bevel gear and hold the right side of the drawer with your right hand.
- d. Turn the bevel gear toward you (counterclockwise). Turning the gear causes the upper pinion to start turning and the upper carriage to start moving in the arrow direction. Then keep turning the bevel gear. (Photo 7)

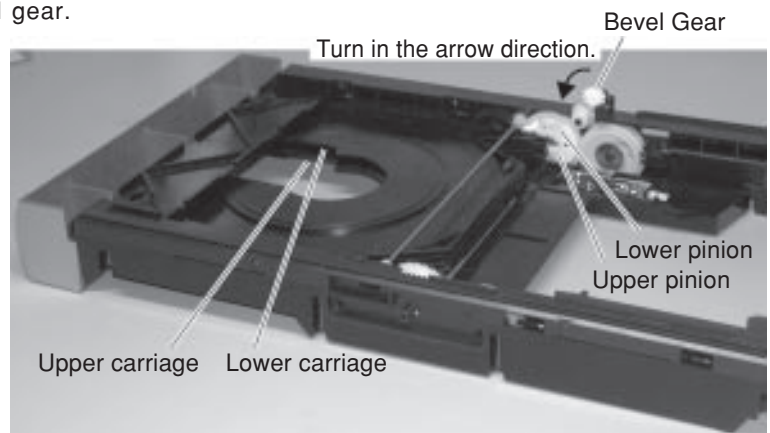

Photo 7

- e. When the upper carriage has reached the rear, pull it up to remove it. (The upper pinion makes 5 full turns before reaching the rear end. The lower carriage drops at the rear end. Leave it as it is in this stage.)  
When removing the upper carriage, its left side should be lifted. However, as the star gear which moves the carriage up and down is in its way, pull the upper carriage diagonally to the upper left while pulling the drawer outward. (Photo 8)
- f. To remove the remaining lower carriage, turn the bevel gear toward you (counterclockwise) again. Then, the lower pinion starts to turn first. Keep turning the bevel gear and the lower pinion stops when it has made 5 full turns. Continue turning the bevel gear and the upper pinion starts to turn. The lower carriage remaining in the drawer then starts to move rearward.
- g. Keep turning the bevel gear until the lower carriage moves to the rear end just like with the upper carriage. Then remove the lower carriage in the same way as before.

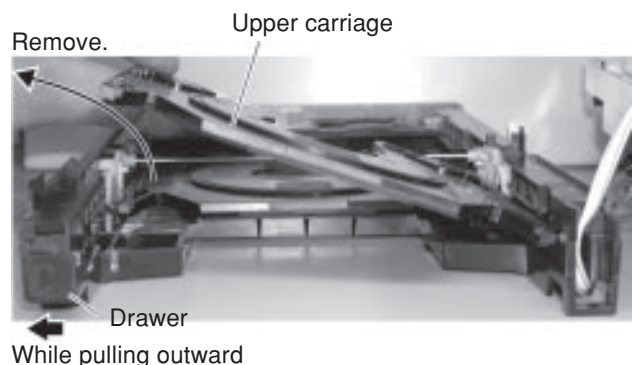
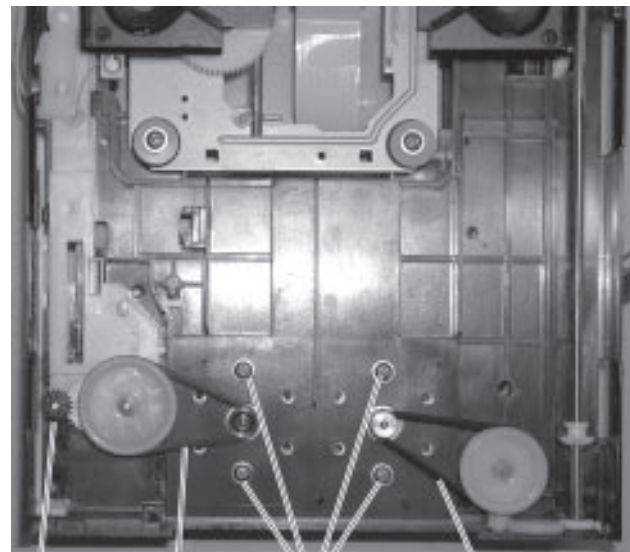

Photo 8  
(Viewed from the rear of the mechanism)

## 5. Replacement of Parts

### 5-1. Replacement of Motor and Belt

- a. Remove the drawer according to Procedures 2 and 3 on page 10.
- b. Using tweezers without non-slip section (to avoid scratching) or a fine stick, remove 2 belts. (Photo 9)
- c. Remove 4 motor mounting screws. (Photo 9)
- d. Turn over the mechanism.  
At this time, be careful not to allow the black gear idler A (Photo 9) and the bevel gear (Photo 6) to come off. They can be removed before turning over the mechanism but if you do so, don't forget to reinstall them before reassembling the mechanism. Without them, the mechanism will not work.



Gear Idler A    Belt with white surface    4 motor mounting screws    Black belt

**Photo 9**

- e. Remove 4 PC board A mounting screws. (Photo 10)
- f. Unsolder the motor terminals and remove the motor. (Photo 10)
- g. Install the replacement motor using 4 screws (Photo 9). (At this time, make sure that the holes in the chassis and installation holes in the motor are at the same positions as before removing the motor. Be careful for the “+” and “-” direction of each terminal. As “+” and “-” are printed on the PC board A, align terminals with them when mounting the motor to the chassis.)
- h. Reinstall the PC board A with screws. (Photo 10)
- i. Solder the motor terminals. (Photo 10)
- j. Reinstall the belts. (Install the belt with white surface to the black pulley and the one with black surface to the metal pulley.) (Photo 9)
- k. Reinstall the drawer as described in Procedure 7 in the later section.

4 PC board A mounting screws

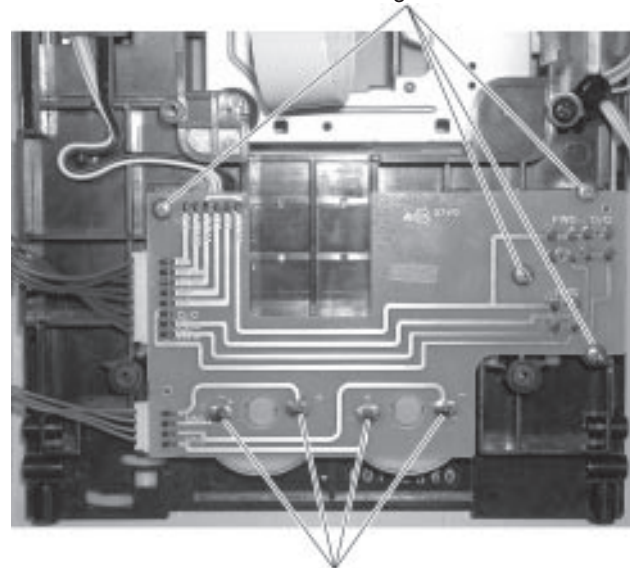

Motor terminals

**Photo 10**

## 5-2. Replacement of Switches

### • Switches 6, 7 and 8

- a. Remove the drawer according to Procedures 2 and 3 on page 10.
- b. Turn over the mechanism.
- c. Remove 4 PC board A mounting screws. (Photo 11)
- d. Unsolder the motor terminals and remove the motor. (Photo 11)
- e. Unsolder the switches. (Photo 11)
- f. Remove the PC board A.
- As a lead wire is connected to the PC board A, it cannot be separated completely.
- g. Replace the switches.
- h. Install the PC board A to the chassis. (Photo 11)
- i. Solder the motor terminals. (Photo 11)
- j. Install the drawer as described later in Procedure 7.

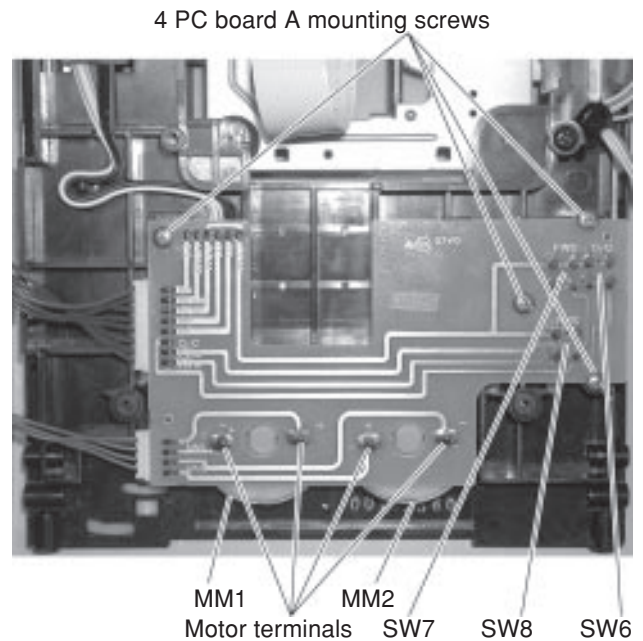

Photo 11

### • Switches 2 and 3

- a. Remove the drawer according to Procedures 2 and 3 on page 10.
- b. Turn over the mechanism.
- c. Remove the screw from the drawer and then the spacer as well.
- d. Push the claw section outward slightly and remove the PC board C from the drawer. (Photo 12)
- e. Unsolder the switch terminals and replace the switches.
- f. Install the PC board to the drawer by reversing the above steps starting with Step d.
- g. Install the drawer as described later in Procedure 7.

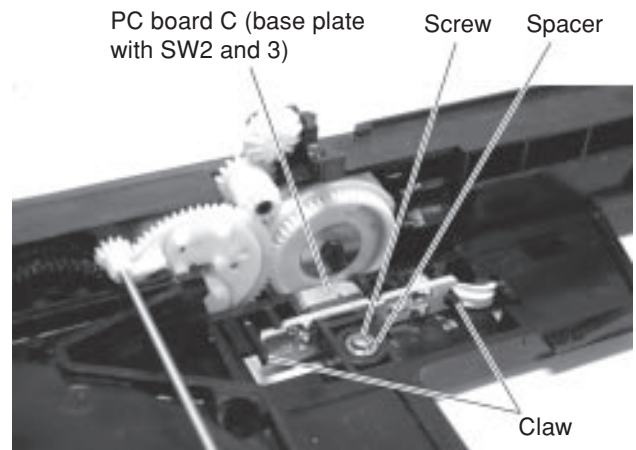
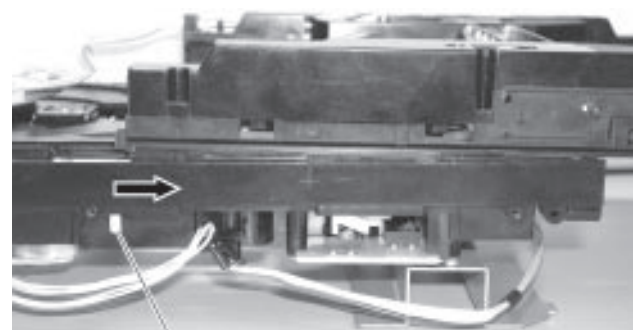

Photo 12

### • Switches 4 and 5

- a. Open the drawer according to Procedure 2 on page 10.
- b. Remove the cover.
- c. Hold the lever projecting from the back of the chassis by the left hand. (Photo 13)



Lever to move sliders 1 and 2.

Photo 13

- d. While moving the arm stopper B in the arrow direction (Photo 14), pull the lever toward you (Photo 13) and lift the arm. (Photo 15)
- e. Remove 2 screws fixing the arm and while pulling the chassis by the part marked with an arrow, remove the arm. (Photo 15)
- f. Remove the carriage located under it as well. (Photo 15)

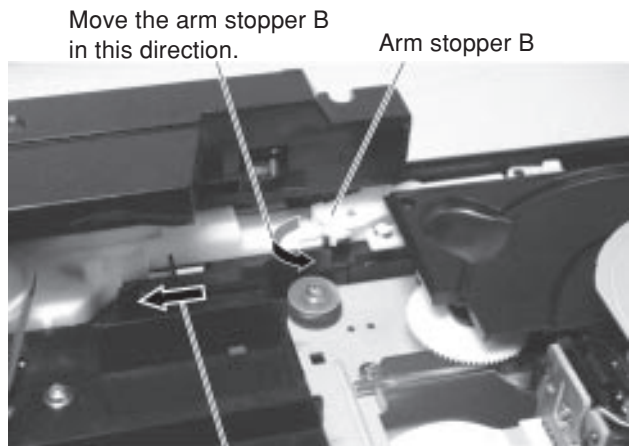

Slider 1 and 2 move in this direction.

**Photo 14**

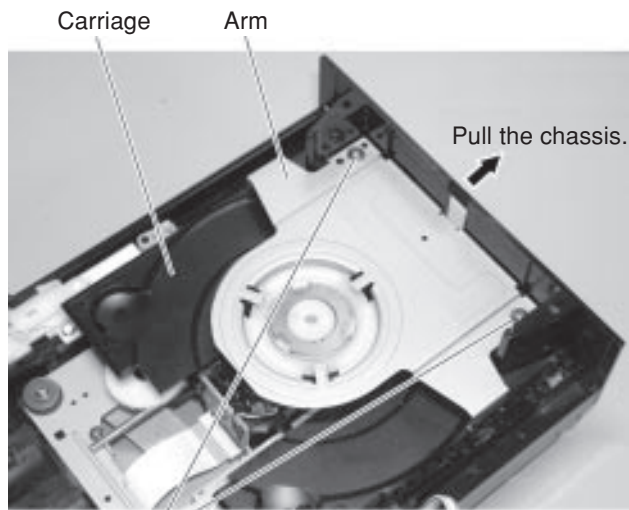

2 arm mounting screws.

**Photo 15**

- g. Remove the lifter and spring located on the right side. Since the front is spring shaped, push this section inward to release it from the claw of the chassis. (Photo 16)

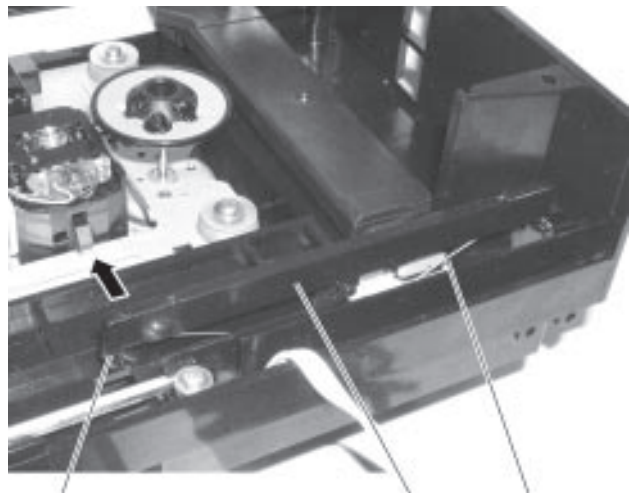

While pushing this part inward, lift the lifter to remove it.

**Photo 16**

- h. While pushing down the point shown in photo 17 with a small tool, like tweezers, move the PC board B to the right to remove it. (Photo 17)
- i. Unsolder the PC board B and replace the switches.
- j. Reversing the above procedure starting from Step “i”, install the PC board B to the chassis and restore the mechanism in the original state.
- k. After installing the lifter, check to ensure that the lifter moves up and down without resistance when it is pushed down.

PC board B (with switches 4 and 5 installed)

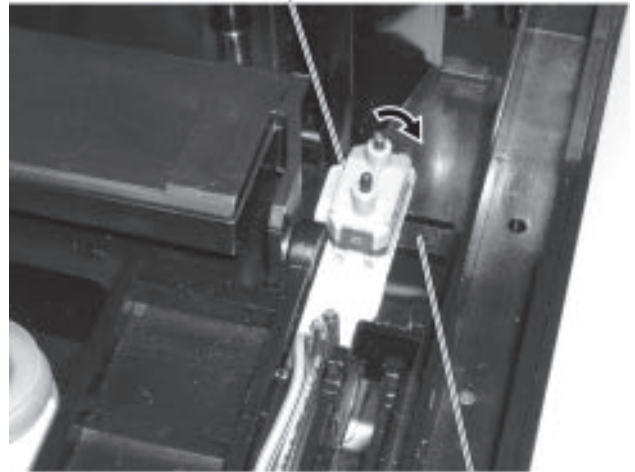

While pushing this part, turn the PC board in the arrow direction to remove it.

**Photo 17**

Member fixing the PC board B

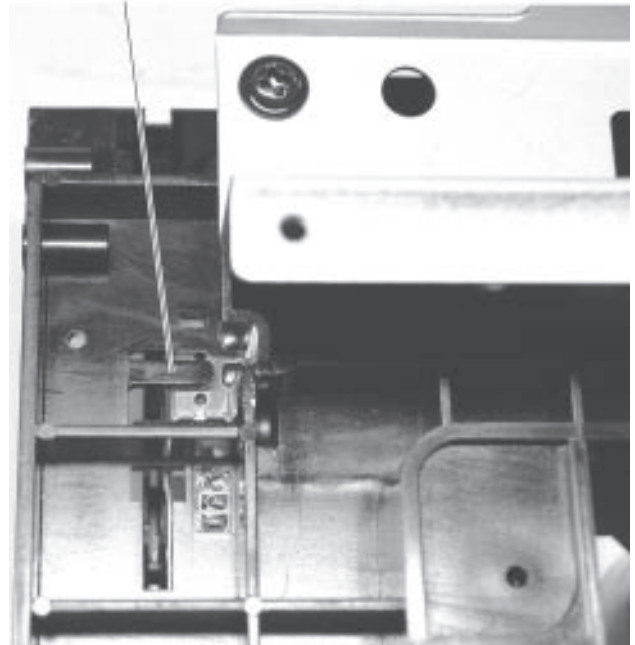

**Photo 18**

**(Chassis viewed from the back)**

**Precaution required when installing the spring to the lifter:**

Fit the end of the spring into a pocket in the lifter at the front and install it to the chassis. (Photo 19)

Pocket to fit in the end of spring    No pocket on this side



**Photo 19**

## 6. Installation of Carriages

- a. Check that the bevel gear is installed to the drawer. If it is not, install it according to Step b of Procedure 4.
- b. Turn the bevel gear toward the rear (clockwise) until the upper pinion starts to turn. (Photo 20)

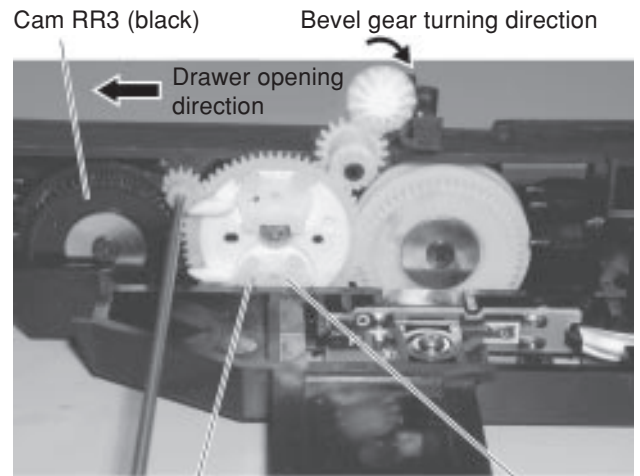

Both marks on upper and lower pinions Upper pinion should be on the cam RR3 side.

Photo 20

- c. Install the carriage (starting with the largest No. one first) so that the first tooth fits between the pins of the upper pinion. (Photos 21 and 22)

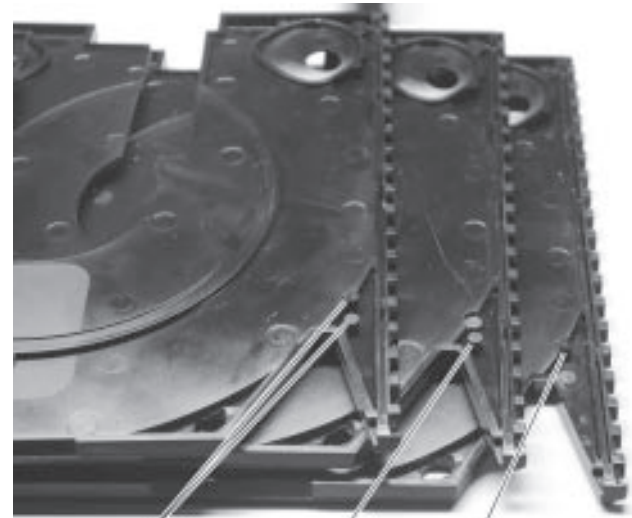

Photo 21

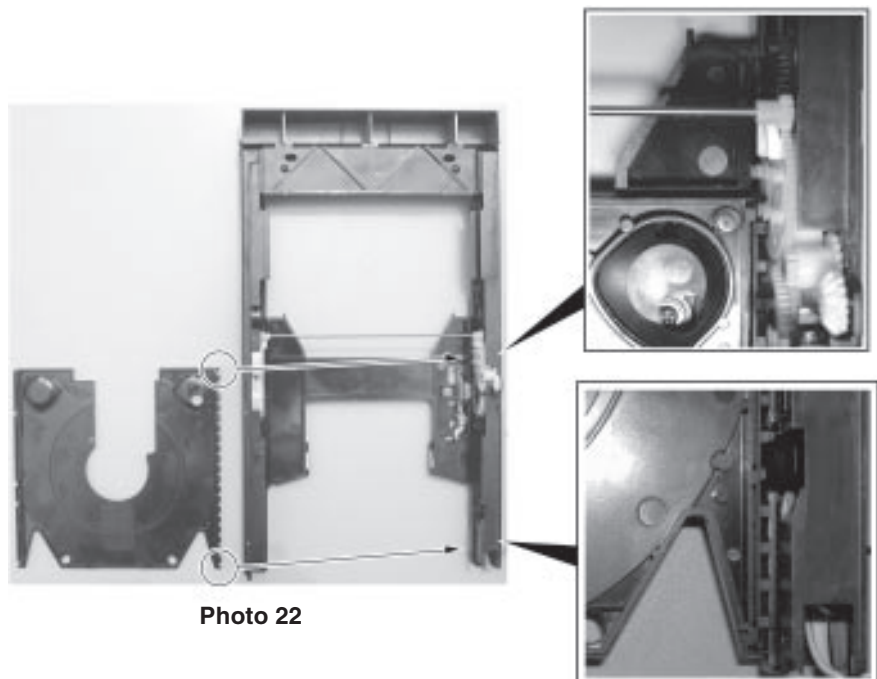
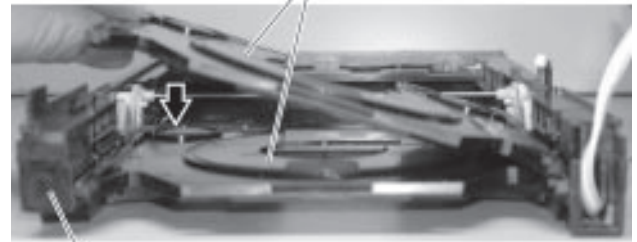

Photo 22



- d. Install the left side of the carriage under the collar of the star gear, and then the right side by pushing it with your fingers. (Photo 23)
- e. Turn the bevel gear toward the rear (clockwise) so that the carriage moves completely forward. (The pinion makes about 5 full turns during this process.)
- f. Keep turning the bevel gear in the same direction, and the lower pinion starts to turn. When the lower pinion stops turning, stop turning the bevel gear. (Photo 25)
- g. Install another carriage in the same manner.
- h. Before turning the bevel gear, push up the carriage that has already moved slightly with hand. (Photo 24)
- i. Turn the bevel gear toward the rear again. The carriage that has moved forward is raised by the start gear first.
- j. Continue turning the bevel gear, and the carriage remaining at the rear moves forward.
- k. In this state, set the drawer back in the original state.

Push in the carriage with fingers.



Drawer

**Photo 23**

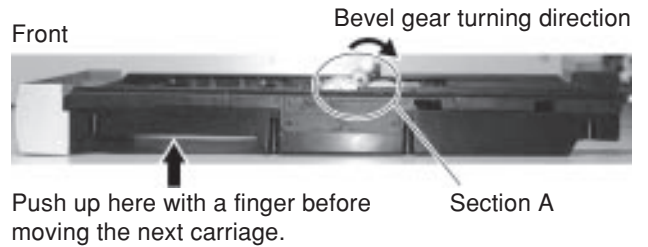

Push up here with a finger before moving the next carriage.

**Photo 24**

Turn the bevel gear continuously after moving the carriage that has been installed first, and the lower pinion starts to turn.

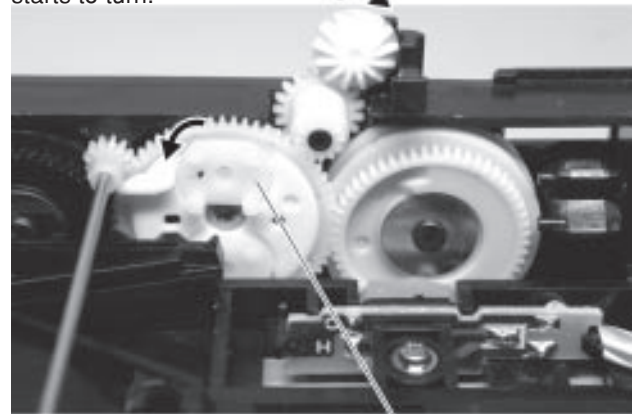

Lower pinion

**Photo 25**

**(Enlarged view of section A)**

- l. Move the cam gear so that the cut line in it is positioned as Photo 26 shows.

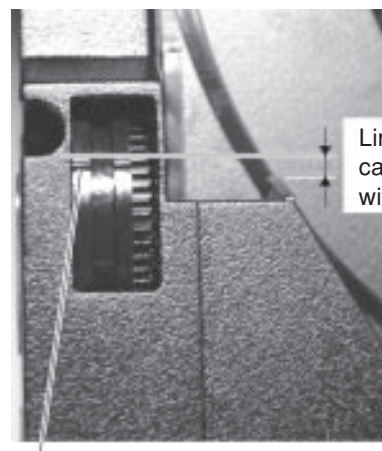

Line on Cam RR3 or RF2

**Photo 26**

## 7. Installation of Drawer

- a. While holding the drawer in the normal operating, align the lug located on the left side of the drawer to the position where the collar of the arm stopper B is and push it into the chassis. (Photo 27)
- b. With the right side of the drawer loose, fit the claw on the left side of the chassis (at the rear) into the groove in the drawer. A light push on the drawer will facilitate fitting. (Photo 28)
- c. Lift the right side of the drawer, and the claw at the front fits in the groove as well.
- d. When the drawer is installed properly, the rack of the drawer should mesh with the gear idler A on the slider 2.
- e. In this state, lower the right side of the drawer to the horizontal level and move forward and rearward by about 5mm to check that there is some resistance. If it moves lightly, move back to Step “a” above to ensure the gear meshed securely. The same is applicable when the arm has lifted. Check that the arm stopper B and slider 2 are meshed and then reinstall the drawer.
- f. Check to make sure that the bevel gear is positioned properly on the chassis and latch the claw on the right side.
- g. Adjust the bevel gear position so that the grooves in the right side of the drawer and in the bevel gear match and make the groove in the right side of the drawer mesh with the chassis claw. (Photos 29 and 30)

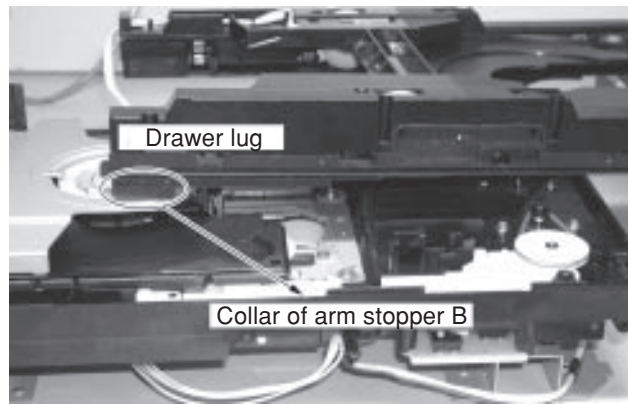
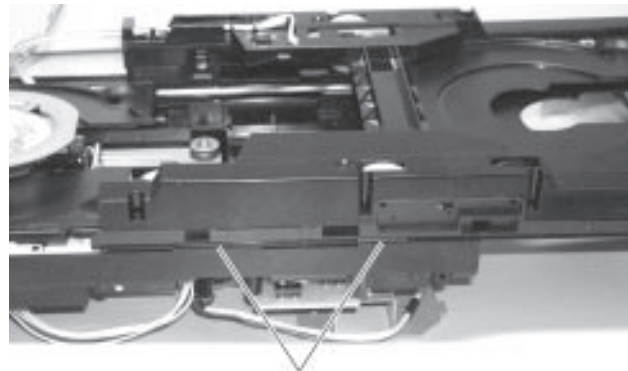

Photo 27



Chassis claws

Photo 28

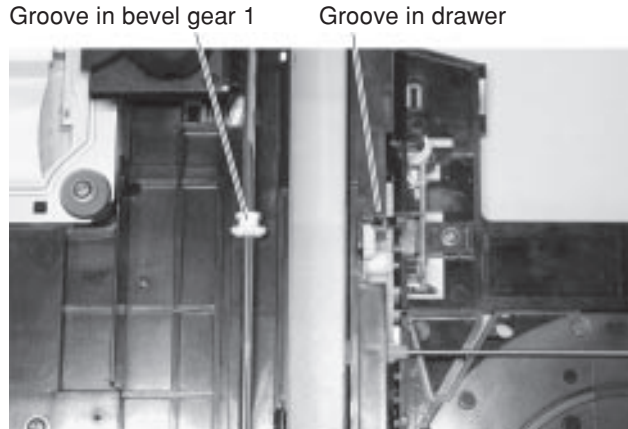
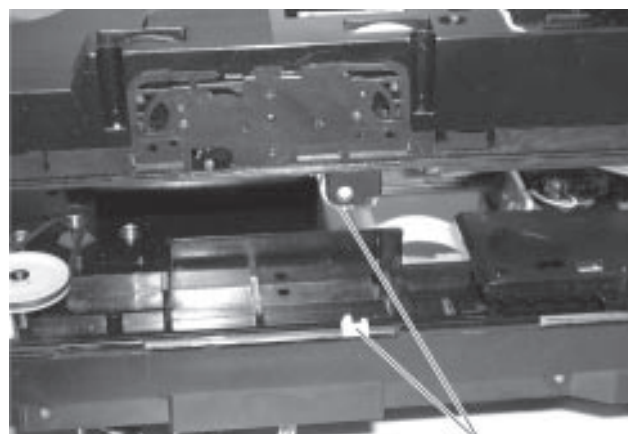

Photo 29



Make chassis claws mesh with the groove in the drawer.

Photo 30

- h. After making sure that the drawer and chassis claws are meshed properly, push in the drawer gradually until it reaches the wall of the chassis. (Photo 31)
- i. Pull the drawer in its opening direction lightly to check that it is locked.

Wall of chassis

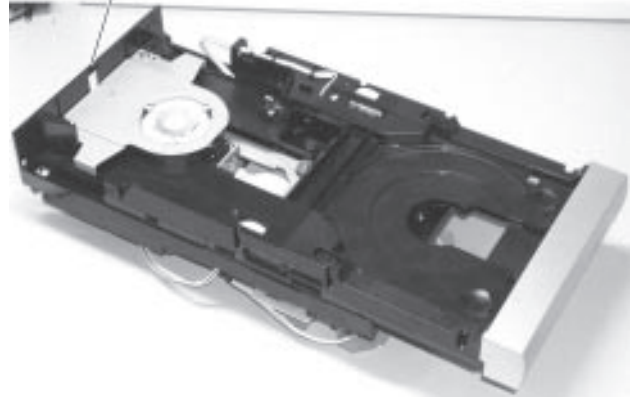
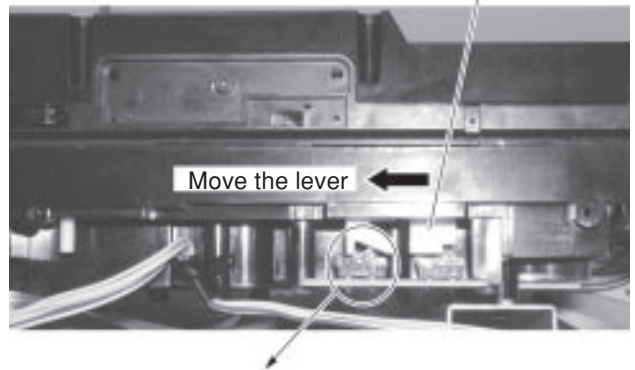

Photo 31

- j. If the drawer has opened, close it again. Then, push in the lever extending from the slider 2 located on the left side toward the rear until the knob of SW7 is pushed. The drawer should be locked in this way. (Photo 32)

Lever extending from slider 2



**Limit for the lever to be pushed**  
 Stop at the position as shown here with respect to SW7.  
 Pushing it excessively will cause the drawer lock to be released.

Photo 32

## ■ STANDARD OPERATION CHART

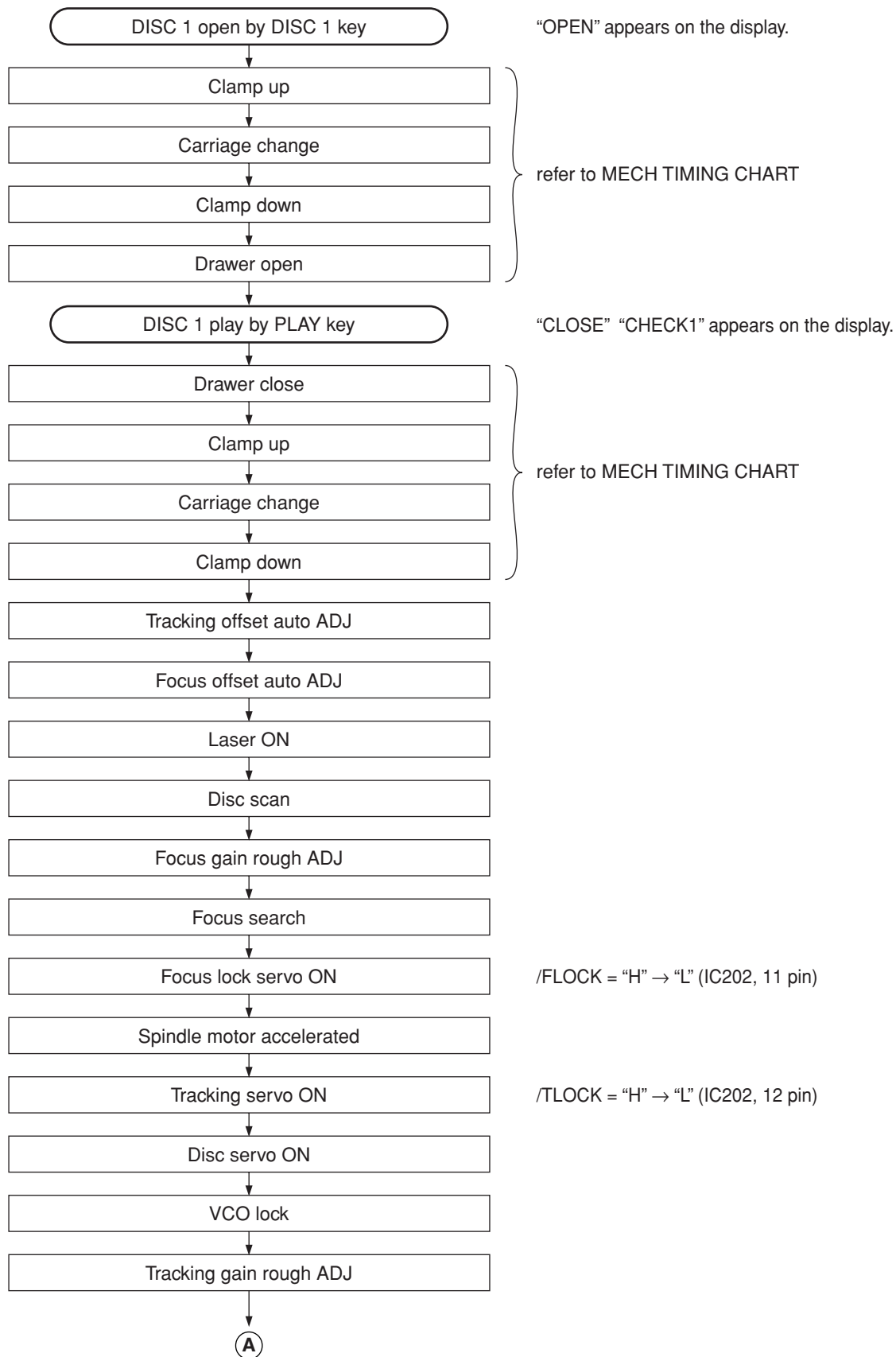

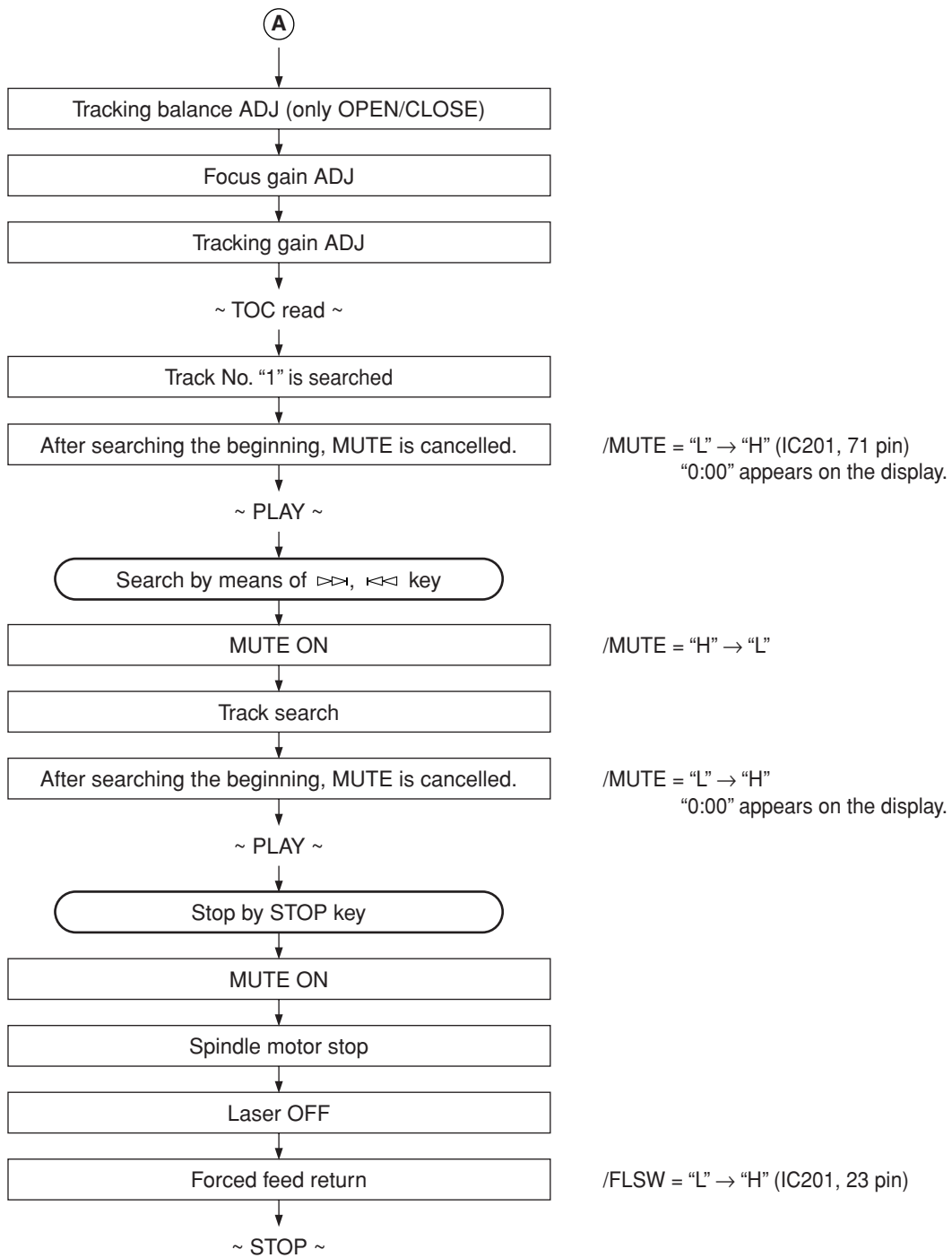

• **CIRCUIT DIAGRAM**

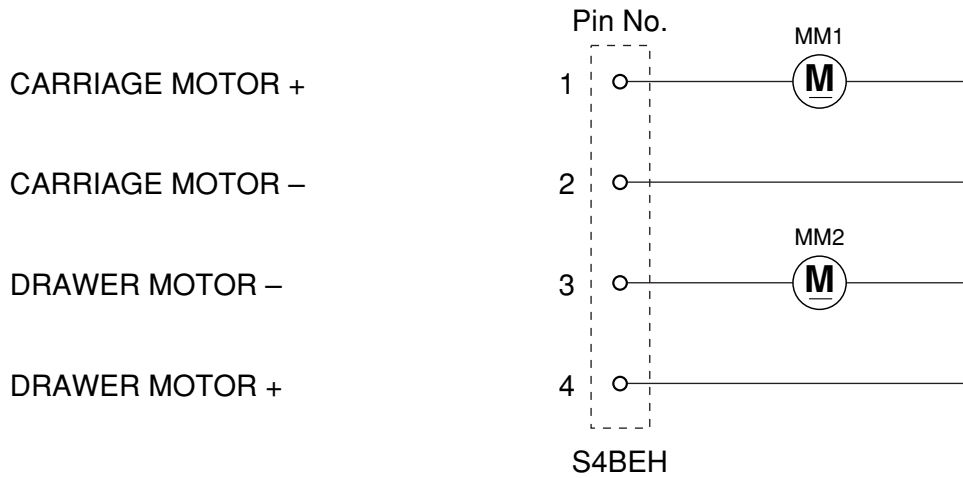
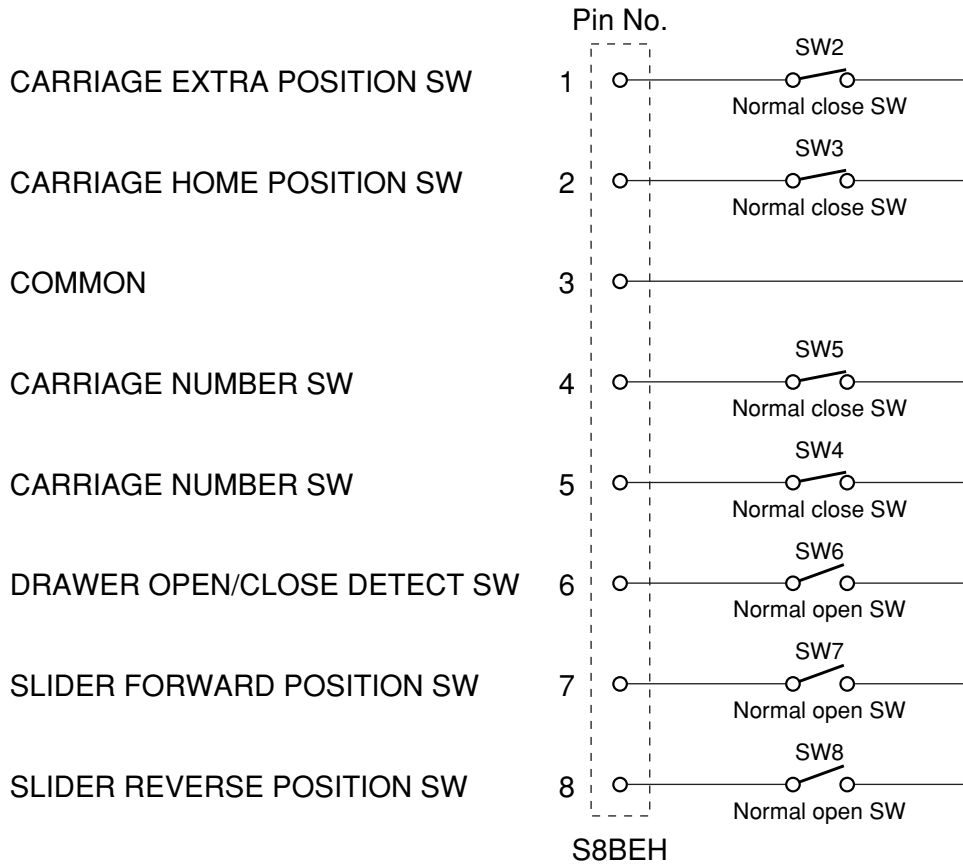

SW4 → OFF, SW5 → ON : CARRIAGE No. 1  
 SW4 → ON, SW5 → OFF : CARRIAGE No. 2  
 SW4 → ON, SW5 → ON : CARRIAGE No. 3

\* See page 13 for specific positions of SW and motor.

• TIMING CHART

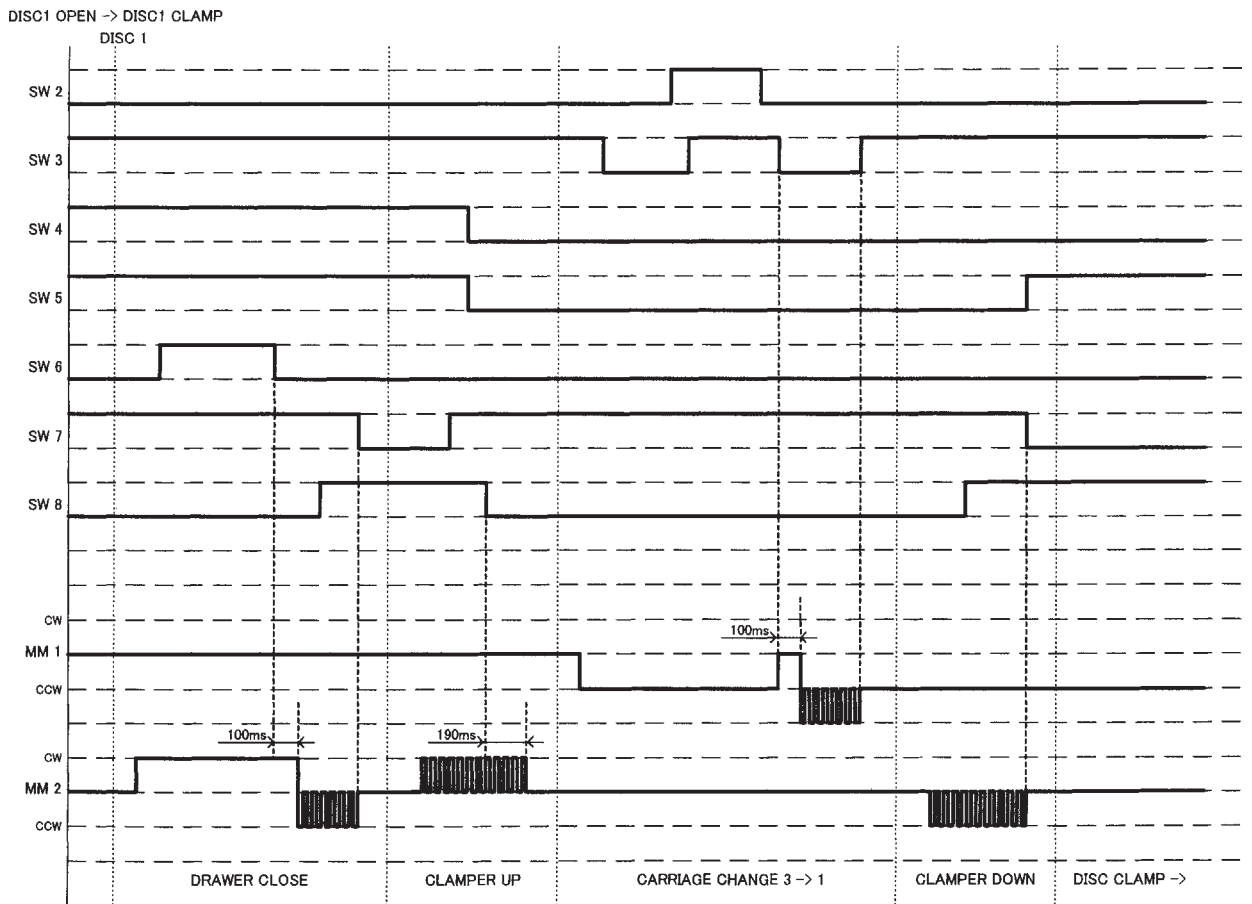
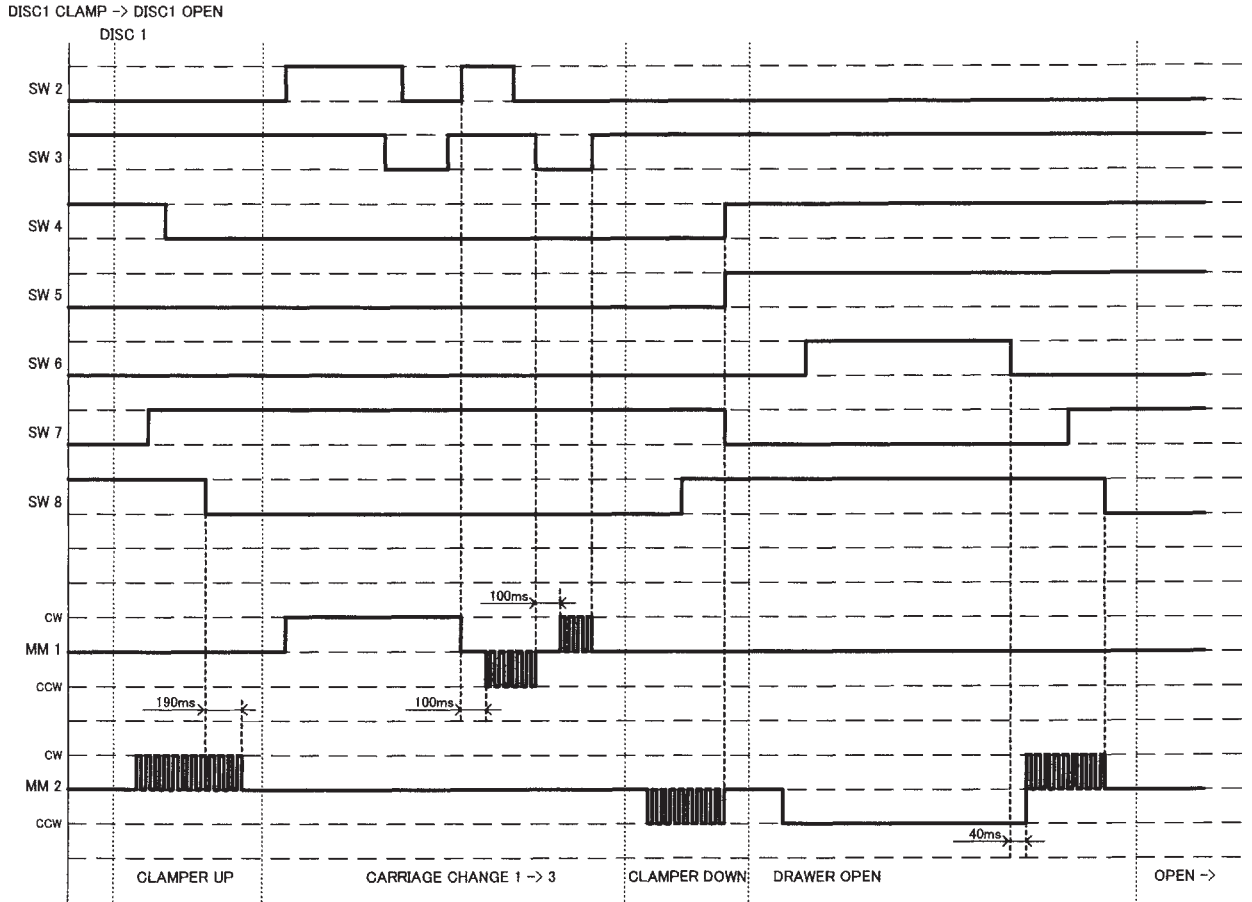

## ■ TEST MODE

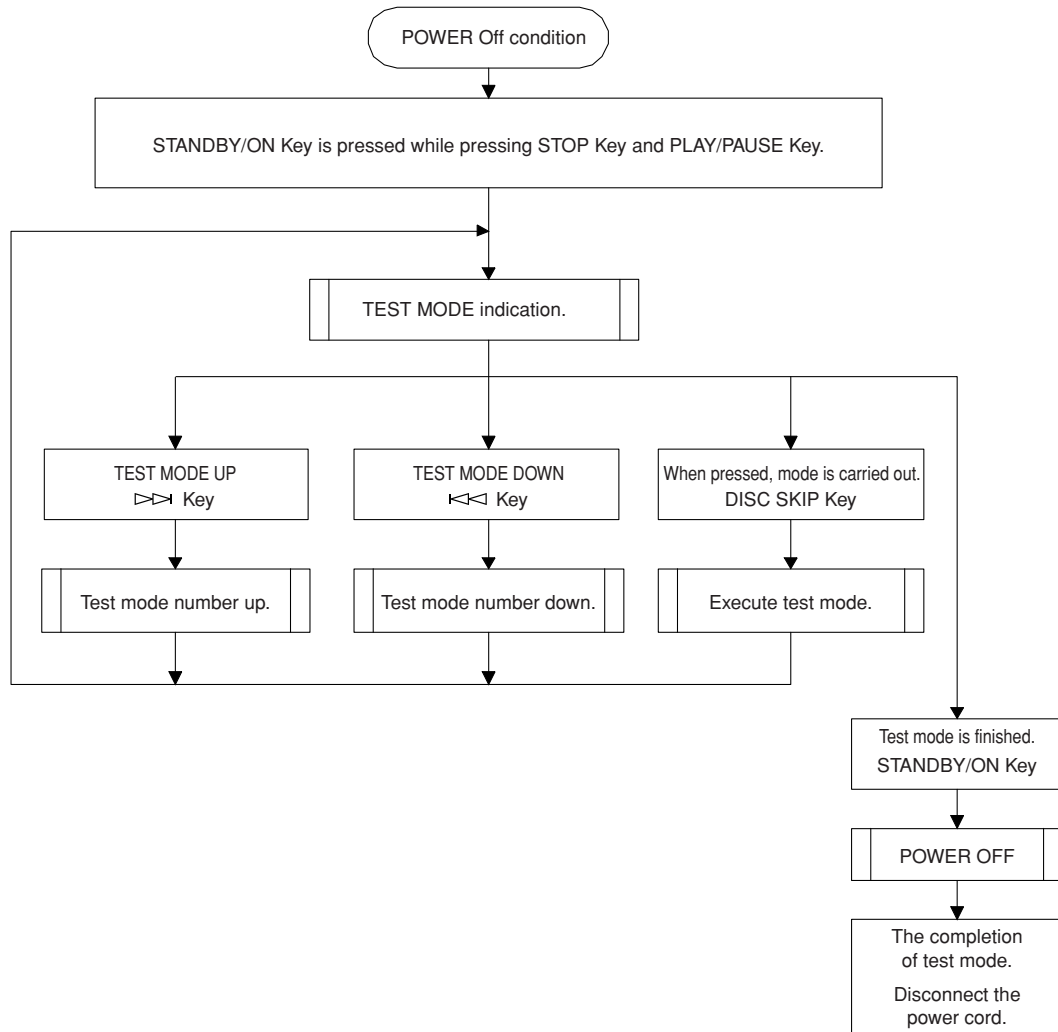

### TEST PROGRAM MODE FUNCTION DESCRIPTION

Command	Function
00:Op/Ci	The tray closes if it is open, and the tray opens if it is closed. Don't carry it out during opening or closing.
01:AT Adj-1	Automatic adjustment 1 (Tracking offset adjustment / Focus offset adjustment / Standby)
02:AT Adj-2	Automatic adjustment 2 (Focus On, Tracking Off / Focus gain approximate adjustment / Standby / Focus search / Disc spin / Focus On, Tracking On / Servo On / EF balance adjustment / Tracking gain approximate adjustment)
03:AT Adj-3	Automatic adjustment 3 (Focus gain precise adjustment / Tracking gain precise adjustment / Focus balance adjustment)
04:TRV Rev	Traverse unit moves toward the inside.
05:TRV Fwd	Traverse unit moves toward the outside.
06:TRV Stop	Traverse unit stops.
07:SP Accel	Spindle motor acceleration.
08:SP Brake	Spindle motor brake.
09:SP S On	Spindle servo On.
10:SP S Off	Spindle servo Off.
11:SP Stop	Spindle motor stop (include 8 sec. waiting).
12:FCS SRH	Focus On, Tracking Off.
13:Tr&Tv Off	Focus On, Tracking Off, Feed Off.
14:1 Kick R	1 Kick in the inside direction is repeated every 30msec.
15:1 Kick F	1 Kick in the outside direction is repeated every 30msec.



Command	Function
16:10 Kick R	10 Kick in the inside direction is repeated every 30msec.
17:10 Kick F	10 Kick in the outside direction is repeated every 30msec.
18:30 Kick R	30 Kick in the inside direction is repeated every 40msec.
19:30 Kick F	30 Kick in the outside direction is repeated every 40msec.
20:150Kick R	150 Kick in the inside direction is repeated every 50msec.
21:150Kick F	150 Kick in the outside direction is repeated every 50msec.
22:Product M	It exits the test mode, and changes to the nominal mode.
23:Error Msg	The error message is displayed.
24:Test Rep	Test repeat is started. (not for service)
25:Test Coef	The following servo establishment value is indicated. It is changed by >>  and  <<. FG / FEXP / FBAL / FOFS / TG / TEXP / TBAL / TOFS / FC / FR / TC / TR / FC2 / TC2 / TR2 / GSET / VSET / SET0 / SET1 / SET2 / TOS2 / FES / TES / CRM2 / SD / KS / SET3
26:Mute Chg	Mute switching (digital, analog or both).
27:FcsG Chg	Focus gain is changed to normal or high.
28:MechaTest	The mechanism endurance test is done. It starts when DISC SKIP is pushed again after selection. It is reset with STOP. (To cancel Mecha Test mode, disconnect the power plug from the outlet.)
29:Mecha	The bridge test of Mecha SW and Mecha Motor is done.
30:FL Check	FL indication check is done. It changes with the DISC SKIP key. It is returned with the STOP key.
31:Shipment	Factory reset. The tray opens. When it is pushed, it closes, and any memory is erased.
32:Soft Ver.	The software version is indicated for three seconds.

#### • Error Messages List

Error No.	Status	Contents
E-10	PLAY	CD fails in the disc data reading after the state shift.
E-20	SCAN	
E-30	PAUSE	
E-70	SEARCH	
E-11	PLAY	CD fails in the disc data reading.
E-21	SCAN	
E-31	PAUSE	
E-73	LOAD	CD fails in the TOC data reading.
E-04	LOAD, SEARCH	Tracking servo is not effective at the DISC MOTOR SERVO PLL.
E-14	LOAD, SEARCH	Disc motor servo PLL is not effective.
E-35		CD fails in FOCUS SEARCH.
E-06	SEARCH, PLAY, PAUSE	CD fails in escaping from the LEAD-IN area.
E-47	SEARCH	The inner limit switch does not operate at the FEED INNER CONTROL.
E-57	STOP	
E-77	LOAD, EJECT	
E-18	PLAY	CD fails in recovery from the FOCUS OUT.
E-28	SCAN	
E-38	PAUSE	
E-48	SEARCH	
E-68	LOAD	

## ■ TROUBLESHOOTING

### <Data cannot be read>

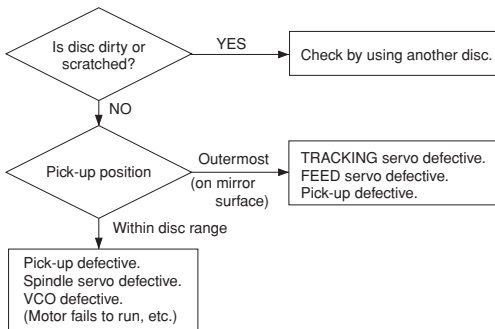

### <Focus drops>

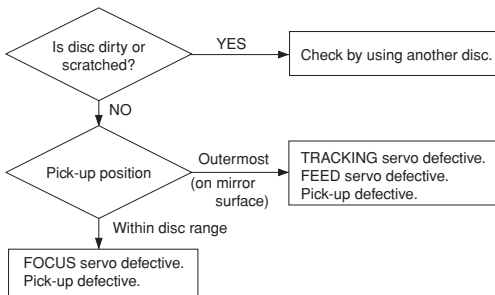

### <Sound skips. (Time display fails to advance properly)>

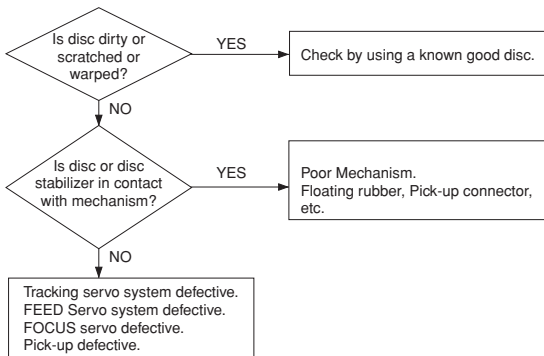

### <No search provided. (Sound skipped after search)>

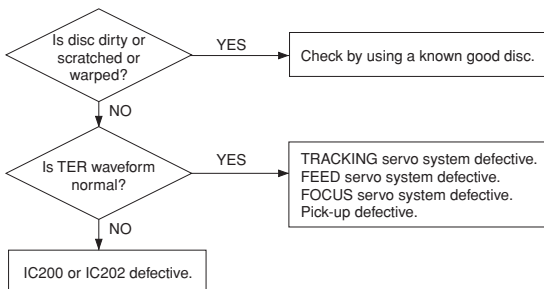

### <No sound generated, Sound cut during play.> (but time display advances properly)

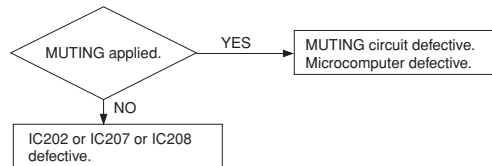

### <Operates as if no disc loaded. (although loaded)>

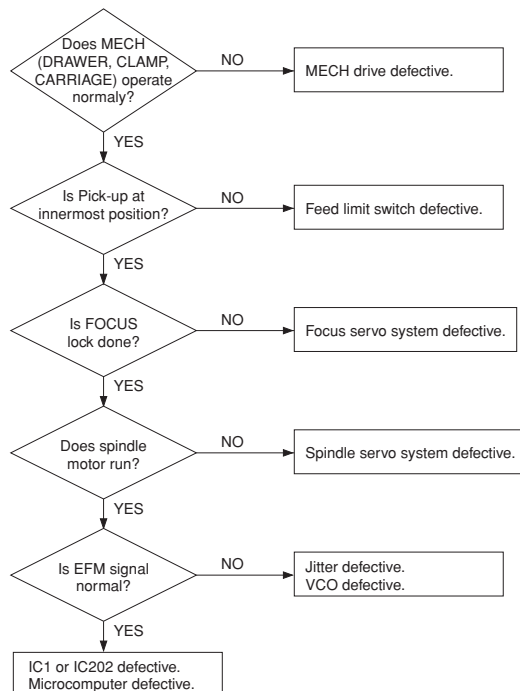

### <MECH abnormal operation>

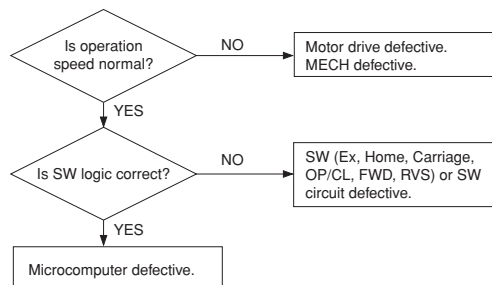

# IC DATA

IC201 : M30622M8A-XXXFP  
16 bit  $\mu$ -COM

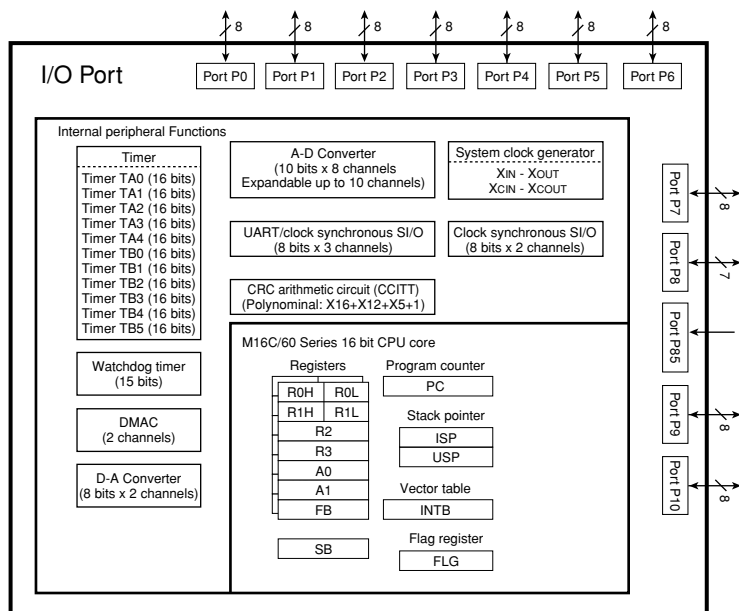
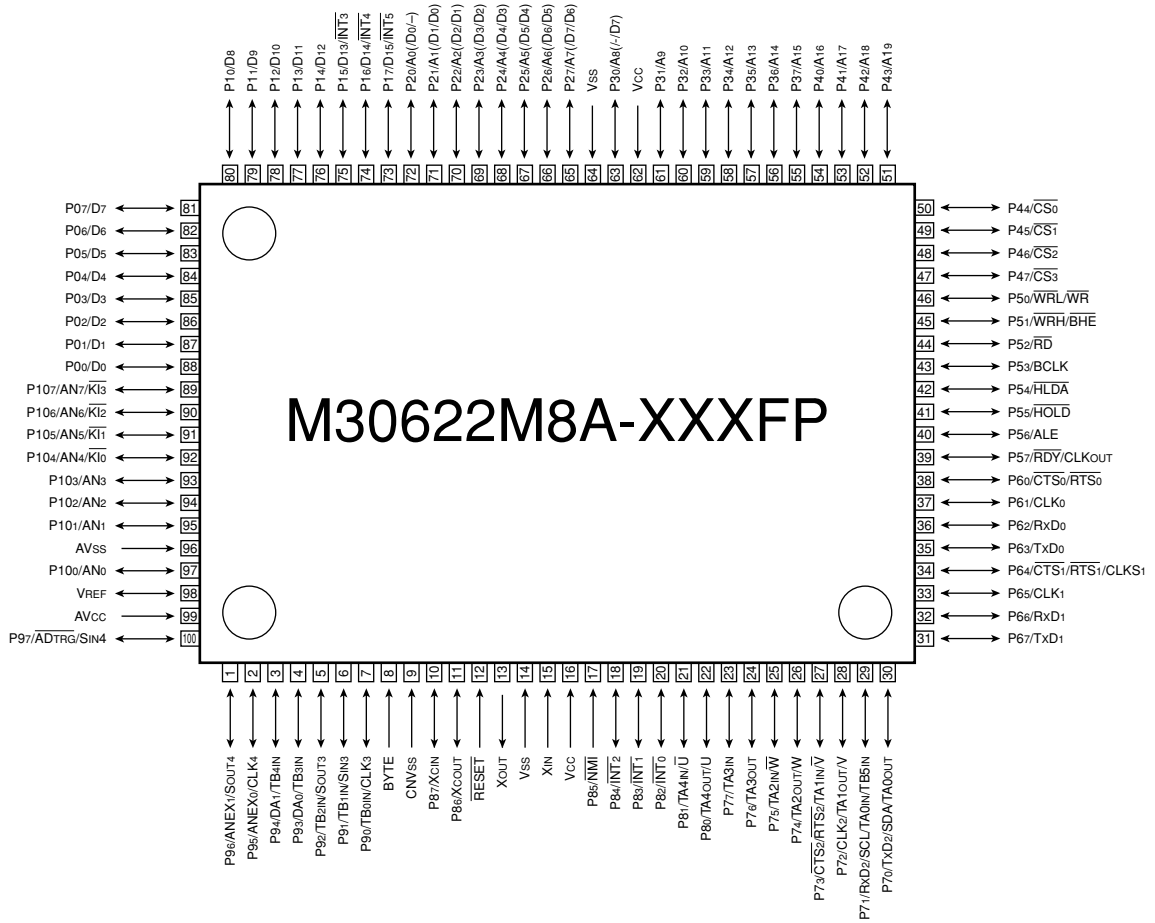

## IC201 : M30622M8A-XXXFP

## Pin Description

No.	Device Name	Source Program Name	Circuit Diagram Name	I/O	Contents	Logic	Other
1	P96/ANEX1/SOUT4			–	Open		
2	P95/ANEX0/CLK4		SQCK	O	MN35511 serial I/F clock (SQCK)		
3	P94/DA1/TB4IN		LDRCTL	O	RF amp gain control	2.5V: Normal L: RW	D/A
4	P93/DA0/TB3IN		GCTL	O	RF amp gain control	H: RW 2.5V: Normal L: Off	D/A
5	P92/TB2IN/SOUT3			–	Open		
6	P91/TB1IN/SIN3	pSUBC	SUBC	I	MN35511 serial I/F input (CDTX)		
7	P90/TB0IN/CLK3		SUBCK2	O	MN35511 C (TXCK)		
8	BYTE		BYTE	–	Gnd	Always low	
9	CNVSS		CNVSS	–	Gnd	Always low	
10	P87/XCIN						
11	P86/XCOUT						
12	RESET		/RESET	–	Reset		
13	XOUT		XOUT	–	Oscillator (10.0 MHz)		
14	VSS		VSS	–	Gnd	Always low	
15	XIN		XIN		Oscillator (10.0 MHz)		
16	VCC		VCC	–	+5V	Always high	
17	P85/NMI		/NMI	–I	+5V (with R)	Always high (with R)	
18	P84/INT2		/CLDCK	I	MN35511 SUBC pack synchronize		
19	P83/INT1		BLKCK	I	MN35511 sub-code block clock		
20	P82/INT0						
21	P81/TA4IN/U	pDMUTE	DMUTE	O	MN35511 digital mute		
22	P80/TA4OUT/U	pSTAT	STAT	I	MN35511 states		
23	P77/TA3IN	pFLSW	/FLSW	I	Feed limit SW		
24	P76/TA3OUT	pTLOCK	/TLOCK	I	MN35511 tracking lock		
25	P75/T2IN/W	pFLOCK	/FLOCK	I	MN35511 focus lock		
26	P74/TA2OUT/W	pRF_OnOff	RF	O	RF amp standby control	H: standby L: ON	
27	P73/CTS2/RTS2/TA1IN/V	pMLD	MLD	O	MN35511 chip select	H → L: Data latch	
28	P72/CLK2/TA1OUT/V						
29	P71/RxD2/SCL/TA0IN/TB5IN						N-OD
30	P70/TxD2/SDA/TA0OUT						N-OD
31	P67/TxD1		DO	O	FL driver serial I/F output (E2P DI)		TxD
32	P66/RxD1	pE2_DI	DI		(E2P DO)		RxD
33	P65/CLK1		CL	O	FL driver serial I/F clock (CL)		SCLK
34	P64/CTS1/RTS1/CTS0/CLKS1	pFL_CE	CE	O	FL driver chip enable	H → L: Data latch	BUSY
35	P63/TxD0	pMDATA	MDATA	O	MN35511 serial I/F output (MDATA)		
36	P62/RxD0	pSENSE	SENSE	I	MN35511 serial I/F input (SENSE)		
37	P61/CLK0		MCLK	O	MN35511 serial I/F clock (MCLK)		
38	P60/CTS0/RTS0	pMNRST	/MNRST	O	MN35511 system reset	H: ON L: Reset	
39	P57/RDY/CLKOUT	pFLRST	/FLRST	O	FL driver reset	H: ON L: Reset	
40	P56/ALE	pE2_CE	E2_CE	O	(E2P CS)		
41	P55/HOLD		FALSH_EPM	–	Flash ROM	Pull down	
42	P54/HLDA						
43	P53/BCLK						
44	P52/RD						
45	P51/WRH/BHE						
46	P50/WRL/WR		FLASH_CE	–	Flash ROM	Pull up	
47	P47/CS3	pTest3		O	Test port		
48	P46/CS2	pTest2		O	Test port		
49	P45/CS1	pTest1		O	Test port		

No.	Device Name	Source Program Name	Circuit Diagram Name	I/O	Contents	Logic	Other
50	P44/CS0	pTest0		O	Test port		
51	P43/A19	pSysIn	SYSCONI	I	System control (In)		
52	P42/A18	pSysOut	SYSCONO	O	System control (Out)		Di
53	P41/A17						
54	P40/A16	pFEOF	FEOF	O	Feed Off	H: OFF L: ON	
55	P37/A15		K0	I	Key input	H: OFF L: ON	
56	P36/A14		K1	I	Key input	H: OFF L: ON	
57	P35/A13		K2	I	Key input	H: OFF L: ON	
58	P34/A12						
59	P33/A11						
60	P32/A10	pK2	KD2	O	Key scan	H: Not scan L: Scan	
61	P31/A9	pK1	KD1	O	Key scan	H: Not scan L: Scan	
62	Vcc		VCC	-	+5V		
63	P30/A8(/-/D7)	pK0	KD0	O	Key scan	H: Not scan L: Scan	
64	Vss		VSS	-	GND	Always low	
65	P27/A7(/D7/D6)						
66	P26/A6(/D6/D5)						
67	P25/A5(/D5/D4)						
68	P24/A4(/D4/D3)						
69	P23/A3(/D3/D2)						
70	P22/A2(/D2/D1)						
71	P21/A1(/D1/D0)	pMute	/MUTE	O	Analog Mute	H: Mute OFF L: Mute ON	
72	P20/A0(/D0/-)	pPUDRV_OnOff	/DRV	O	Driver standby control	H: ON L: Standby	
73	P17/D15/INT5						
74	P16/D14/INT4						
75	P15/D13/INT3						
76	P14/D12						
77	P13/D11	pMM1_CW	MM1+	O	Carriage motor drive	H: Drive L: OFF	
78	P12/D10	pMM1_CCW	MM1-	O	Carriage motor drive	H: Drive L: OFF	
79	P11/D9	pMM2_CCW	MM2-	O	Drawer motor drive	H: Drive L: OFF	
80	P10/D8	pMM2_CW	MM2+	O	Drawer motor drive	H: Drive L: OFF	
81	P07/D7	pMechaSW8	RVS	I	Slider reverse position SW	H: OFF L: ON	
82	P06/D6	pMechaSW7	FWD	I	Slider forward position SW	H: OFF L: ON	
83	P05/D5	pMechaSW6	O/C	I	Drawer open/close detect SW	H: OFF L: ON	
84	P04/D4	pMechaSW4	D1	I	Carriage number SW	H: ON L: OFF	
85	P03/D3	pMechaSW5	D2	I	Carriage number SW	H: ON L: OFF	
86	P02/D2	pMechaSW3	HOME	I	Carriage home position SW	H: ON L: OFF	
87	P01/D1	pMechaSW2	EX	I	Carriage Extra position SW	H: ON L: OFF	
88	P00/D0						
89	P107/AN7/KI3						
90	P106/AN6/KI2						
91	P105/AN5/KI1						
92	P104/AN4/KI0						
93	P103/AN3						
94	P102/AN2						
95	P101/AN1						
96	AVss		AVSS		GND	Always low	
97	P100/AN0						
98	VREF		VREF		+5V	Always High	
99	AVcc		AVCC		+5V	Always High	
100	P97/ADTRG/SIN4	pSUBQ	SUBQ	I	MN35511 serial I/F input (SUBQ)		

KEY INPUT

	KD0	KD1	KD2
K0	POWER	DISC CHANGE	DISC 3
K1	◀▶	PLAY/PAUSE	DISC 2
K2	▶▶	STOP	DISC 1

IC202 : MN35511AL  
Signal Processor & Controller

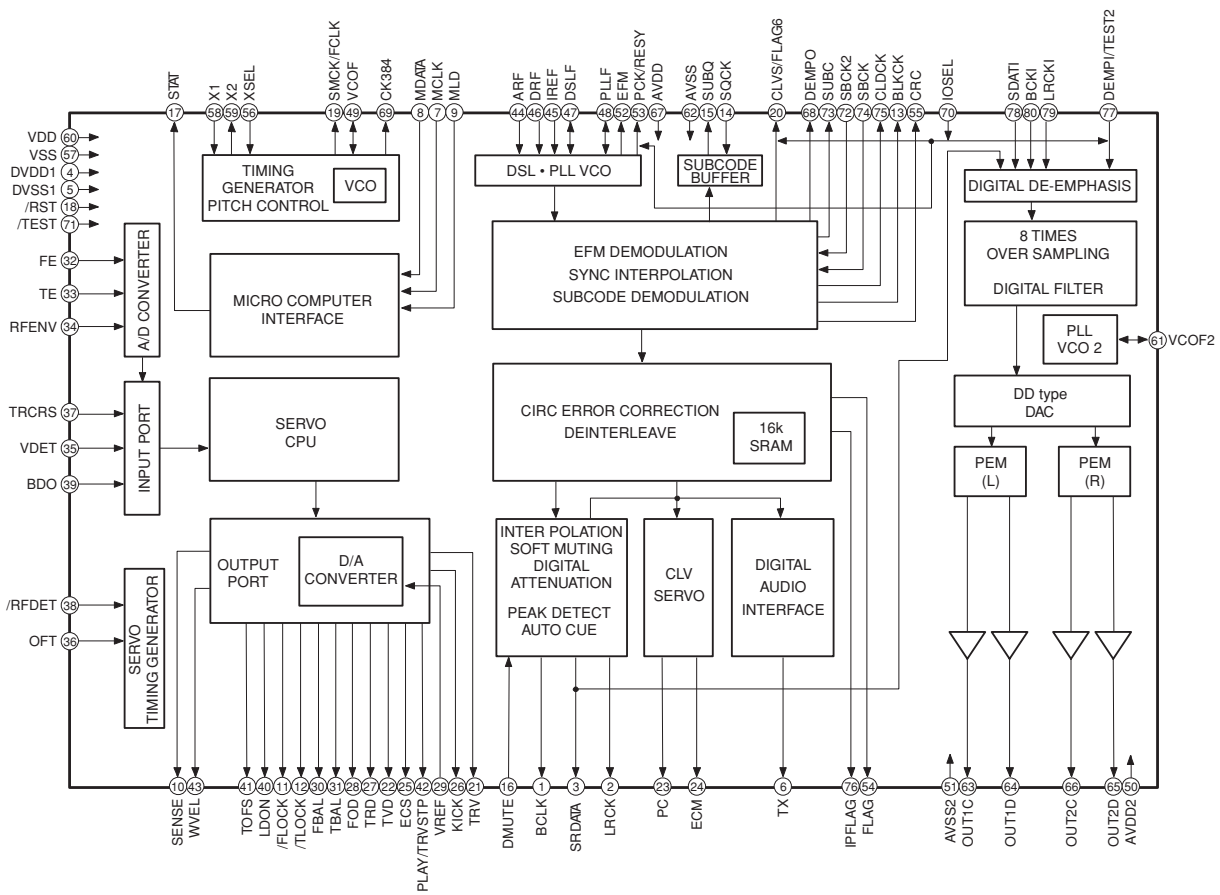

## IC202 : MN35511AL

## Pin Description

Pin No.	Name	I/O	Function
1	BCLK	O	Bit clock output for SR DATA (NC)
2	LRCK	O	L/R identification signal output (NC)
3	SRDATA	O	Serial data output (NC)
4	DVDD1	I	Power supply for digital circuit (+5)
5	DVSS1	I	GND for digital circuit
6	TX	O	Digital, audio, interface output signal
7	MCLK	I	Microprocessor command clock signal input (data latched at leading edge)
8	MDATA	I	Microprocessor command data input
9	MLD	I	Microprocessor command load signal input (L : LOAD)
10	SENSE	O	Sense signal output (OFT, FESL, NACEND, NAJEND, SFG, NWTEND)
11	FLOCK	O	Focus servo drawing signal (L : when drawn)
12	TLOCK	O	Tracking servo drawing signal (L : when drawn)
13	BLKCK	O	Sub code block clock signal (BLKCK=75Hz)
14	SQCK	I	Clock input for sub-code Q register
15	SUBQ	O	Sub-code Q code output
16	DMUTE	I	Muting input (H : MUTE)
17	STAT	O	Status signal (CRC, STCNT, CLVS, TTSTOP, SQOK, RESY, FCLV, FLAG6, SENSE, /FLOCK, /RFDET, /TLOCK)
18	RST	I	Reset input (L : RESET)
19	SMCK/ FCLK	O	4.2336MHz clock signal output SMCK when command is defaulted. (Note 1) (NC) SMCK (8.4672MHz), FCLK (7.35kHz) or "L" fixed is selected when command is switched.
20	CLVS/ FLAG6	O	With command defaulted : CLVS when IOSEL=H, FLAG6 when IOSEL=L (NC) These settings can be reversed by command (FLAG6 when IOSEL=H).
21	TRV	O	Traverse (Feed) forced feed output 3-State
22	TVD	O	Traverse (Feed) drive output
23	PC	O	Spindle motor ON signal L : ON (default) (NC)
24	ECM	O	Spindle motor drive signal (forced mode output) 3-State
25	ECS	O	Spindle motor drive signal (servo error signal output)
26	KICK	O	Kick pulse output 3-State
27	TRD	O	Tracking drive output
28	FOD	O	Focus drive output
29	VREF	I	Reference voltage for DA output block (TVD, ECS, TRD, FOD, FBAL, TBAL)
30	FBAL	O	Focus balance adjustment output
31	TBAL	O	Tracking balance adjustment output
32	FE	I	Focus error signal input (analog input)
33	TE	I	Tracking error signal input (analog input)
34	RFENV	I	RF envelope signal input (analog input)
35	VDET	I	Oscillation detect signal input (H : DETECT) (GND)
36	OFT	I	Off track signal input (H : OFF TRACK)
37	TRCRS	I	Track cross signal input (analog input)
38	RFDET	I	RF detect signal input (L : DETECT)
39	BDO	I	Drop out signal input (H : DROP OUT)
40	LDON	O	Laser ON signal output (H : ON) (NC)
41	TOFS	O	Tracking offset adjustment output (NC)
42	PLAY/TRVSTOP	O	Switched by command. PLAY (Play signal output) when command is defaulted. (NC)
43	WVEL	O	Double speed status signal output (H : double speed) (NC)
44	ARF	I	RF signal input
45	IREF	I	Reference current input terminal
46	DRF	I	Bias terminal for DSL

Note: At the SMCK/FCLK pin, output does not stop while /RST=L.

Pin No.	Name	I/O	Function
47	DSLFB	I/O	Loop filter terminal for DSL
48	PLLF	I/O	Loop filter terminal for PLL
49	VCOF	I/O	Loop filter terminal for VCO (+5)
50	AVDD2	I	Power supply for analog circuit (for AD of DSL, PLL, DA output blocks) (+5)
51	AVSS2	I	GND for analog circuit (for AD of DSL, PLL, DA output blocks) (GND)
52	EFM	O	EFM signal output (NC)
53	PCK/ RESY	O	With command defaulted : PLL extract clock output PCK when IOSEL=H, frame re-synchronous signal RESY when IOSEL=L These settings can be reversed by command (RESY when IOSEL=H). (NC)
54	FLAG	O	Flag signal output (NC)
55	CRC	O	Sub-code CRC check result output (H : OK, L : NG) (NC)
56	XSEL	I	L : Normal mode (GND) H : • For internal master clock, VCO2 output clock for jitter adsorbing PLL is used instead of Xtal oscillation output (X2). • VCO2 is always fixed to oscillation mode regardless of VCO2 oscillation stop command or resetting (/RST=L) and Xtal oscillation is stopped.
57	VSS	I	GND for oscillation circuit
58	X1	I	Crystal oscillation circuit input terminal
59	X2	O	Crystal oscillation circuit output terminal
60	VDD	I	Power supply for oscillation circuit (+5)
61	VCOF2	O	PLL loop filter terminal for jitter adsorption (GND)
62	AVSS1	O	GND for audio DAC
63	OUT1C	O	PEM output terminal 1C
64	OUT1D	O	PEM output terminal 1D
65	OUT2D	O	PEM output terminal 2D
66	OUT2C	O	PEM output terminal 2C
67	AVDD1	I	Power supply terminal for audio DAC
68	DEMPO	O	Deemphasis detect signal output (NC)
69	CK384	O	384fs clock output (At the CK384 pin, output does not stop while /RST=L.) (NC) Xtal system when command is defaulted. Signal processing system when command is switched
70	IOSEL	I	Mode selecting terminal (+5)
71	TEST	I	Test mode setting terminal (Normal : H) (+5)
72	SBCK2	I	Sub-code data read clock input
73	SUBC	O	Sub-code serial output (SBCK effective) when command is defaulted. PACK data usable (SBCK2 effective) when command is switched
74	SBCK	I	Clock input for sub-code serial output (with pull-up resistor) (NC)
75	CLDCK	O	Sub-code frame clock signal output when command is defaulted (fCLDCK=7.35kHz) PACK synchronous signal when command is switched
76	IPFLAG	O	Interpolation flag signal output (H : INTERPOLATION) (NC)
77	DEMPI /TEST2	I	When IOSEL=H, L : NORMAL H : TEST2 (GND) Emphasis control in accordance with DEMPO When IOSEL=L, external DEMP1 input terminal For emphasis control, DEMPO, OR of DEMP1, DEMP1, forced OFF or forced ON is selected by command. When command is defaulted, DEMPO and OR of DEMP1
78	SDATI	I	SRDATA input (effective only when IOSEL=L) (NC)
79	LRCKI	I	LRCK input (effective only when IOSEL=L) H : Lch data, L : Rch data (NC)
80	BCKI	I	BCK input (effective only when IOSEL=L) (NC)

\* The PEM is the abbreviation for the Pulse Edge Modulation.



1

### ■ DISPLAY DATA

● V300 : 14-BT-66GN (V6951300)

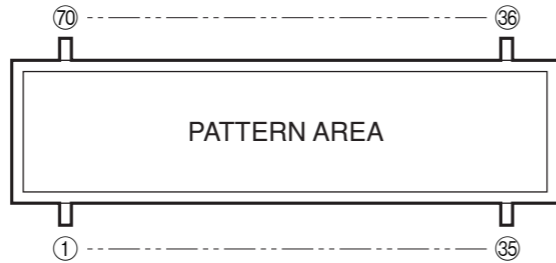

### ● PIN CONNECTION

Pin No.	70	69	68	67	66	65	64	63	62	61	60	59	58	57	56	55	54	53	52	51	50	49	48	47	46	45	44	43	42	41	40	39	38	37	36	
Connection	F1	F1	NP	P1	P2	P3	P4	P5	P6	P7	P8	P9	P10	P11	P12	1C	NX	NX	NX	NX	P13	P14	P15	P16	P17	P18	P19	P20	P21	P22	P23	P24	P25	NP	F2	F2
Pin No.	1	2	3	4	5	6	7	8	9	10	11	12	13	14	15	16	17	18	19	20	21	22	23	24	25	26	27	28	29	30	31	32	33	34	35	
Connection	F1	F1	NP	14G	13G	12G	11G	10G	9G	8G	7G	6G	5G	4G	3G	2G	NX	NX	NX	NX	1G	1C	P35	P34	P33	P32	P31	P30	P29	P28	P27	P26	NP	F2	F2	

Note : 1) F1, F2 ..... Filament 2) NP ..... No pin 3) NX ..... No extend pin 4) DL ..... Datum Line 5) 1G ~ 14G ..... Grid

### ● GRID ASSIGNMENT

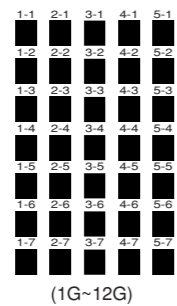
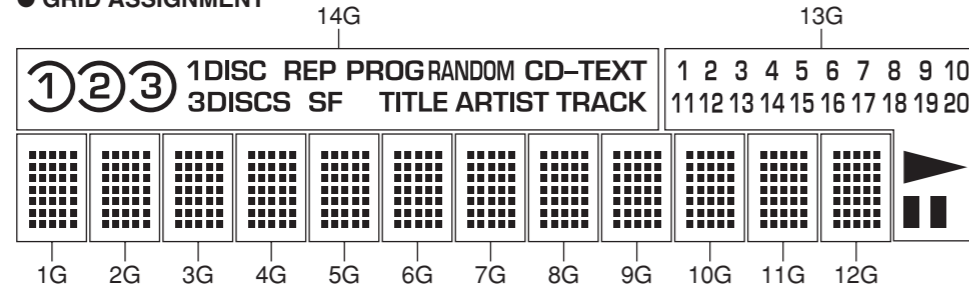

### ● ANODE CONNECTION

	14G	13G	12G~1G
P1	1	1	1-1
P2	⊙ (1)	2	2-1
P3	2	3	3-1
P4	⊙ (2)	4	4-1
P5	3	5	5-1
P6	⊙ (3)	6	1-2
P7	1DISC	7	2-2
P8	3DISCS	8	3-2
P9	REP	9	4-2
P10	S	10	5-2
P11	F	11	1-3
P12	PROG	12	2-3
P13	RANDOM	13	3-3
P14	-	14	4-3
P15	-	15	5-3
P16	-	16	1-4
P17	TITLE	17	2-4
P18	ARTIST	18	3-4

	14G	13G	12G~1G
P19	TRACK	19	4-4
P20	CD-TEXT	20	5-4
P21	-	-	1-5
P22	-	-	2-5
P23	-	-	3-5
P24	-	-	4-5
P25	-	▶	5-5
P26	-	⏸	1-6
P27	-	-	2-6
P28	-	-	3-6
P29	-	-	4-6
P30	-	-	5-6
P31	-	-	1-7
P32	-	-	2-7
P33	-	-	3-7
P34	-	-	4-7
P35	-	-	5-7

2

3

4

5

6

7

### ■ REMOTE CONTROL

#### ● SCHEMATIC DIAGRAM

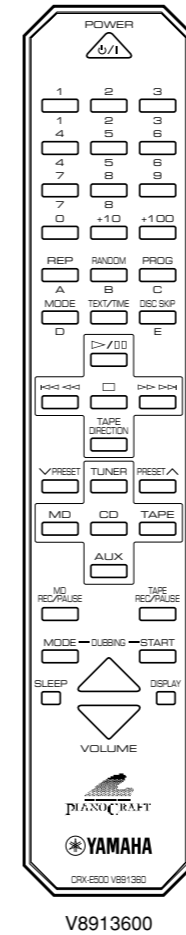
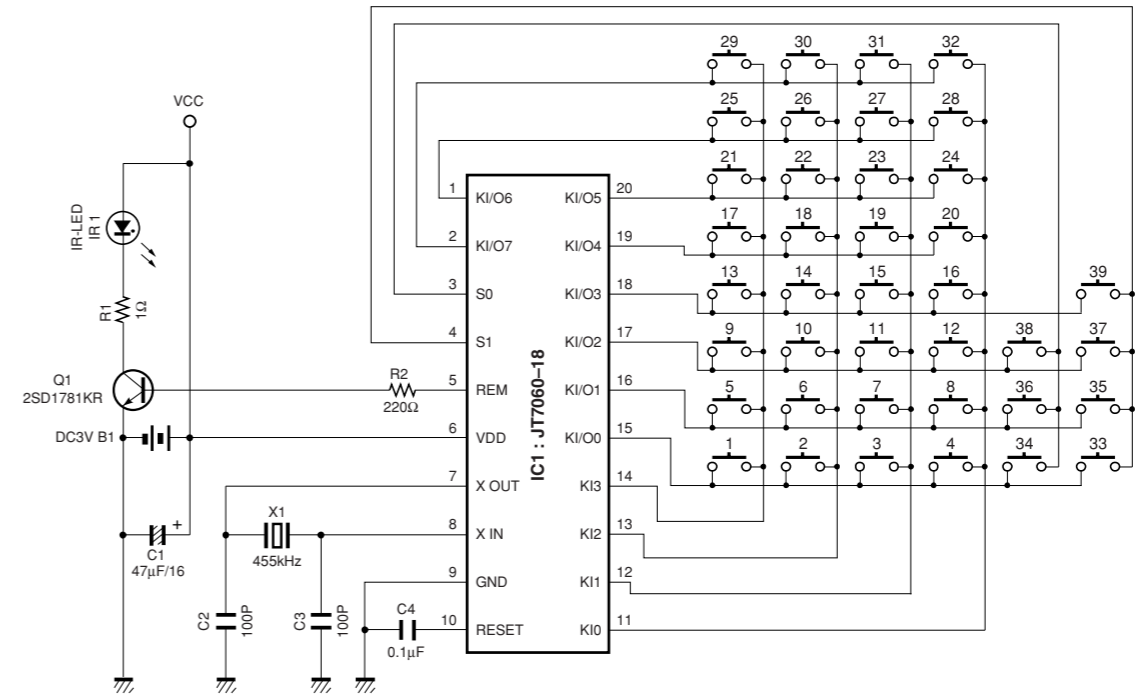

TRANSMISSION FORMAT: NEC-FORMAT  
CUSTOM CODE (HEX): 78

Key No.	Key Name	Data Code (HEX)	Key No.	Key Name	Data Code (HEX)
1	POWER	0F	21	◀◀	04
2	1	11	22	□	01
3	2	12	23	▶▶	03
4	3	13	24	TAPE DIRECTION	43
5	4	14	25	∨ PRESET	1C
6	5	15	26	TUNER	4B
7	6	16	27	PRESET ^	1B
8	7	17	28	MD	57
9	8	18	29	CD	4A
10	9	19	30	TAPE	41
11	0	10	31	AUX	49
12	+10	1A	32	MD REC/PAUSE	58
13	+100	1D	33	TAPE REC/PAUSE	46
14	REP (A)	0C	34	MODE	05
15	RANDOM (B)	07	35	START	06
16	PROG (C)	0B	36	SLEEP	4F
17	MODE (D)	09	37	VOLUME ^	1E
18	TEXT/TIME	0A	38	DISPLAY	4E
19	DISC SKIP (E)	08	39	VOLUME ^	1F
20	>/□	02			

# BLOCK DIAGRAM

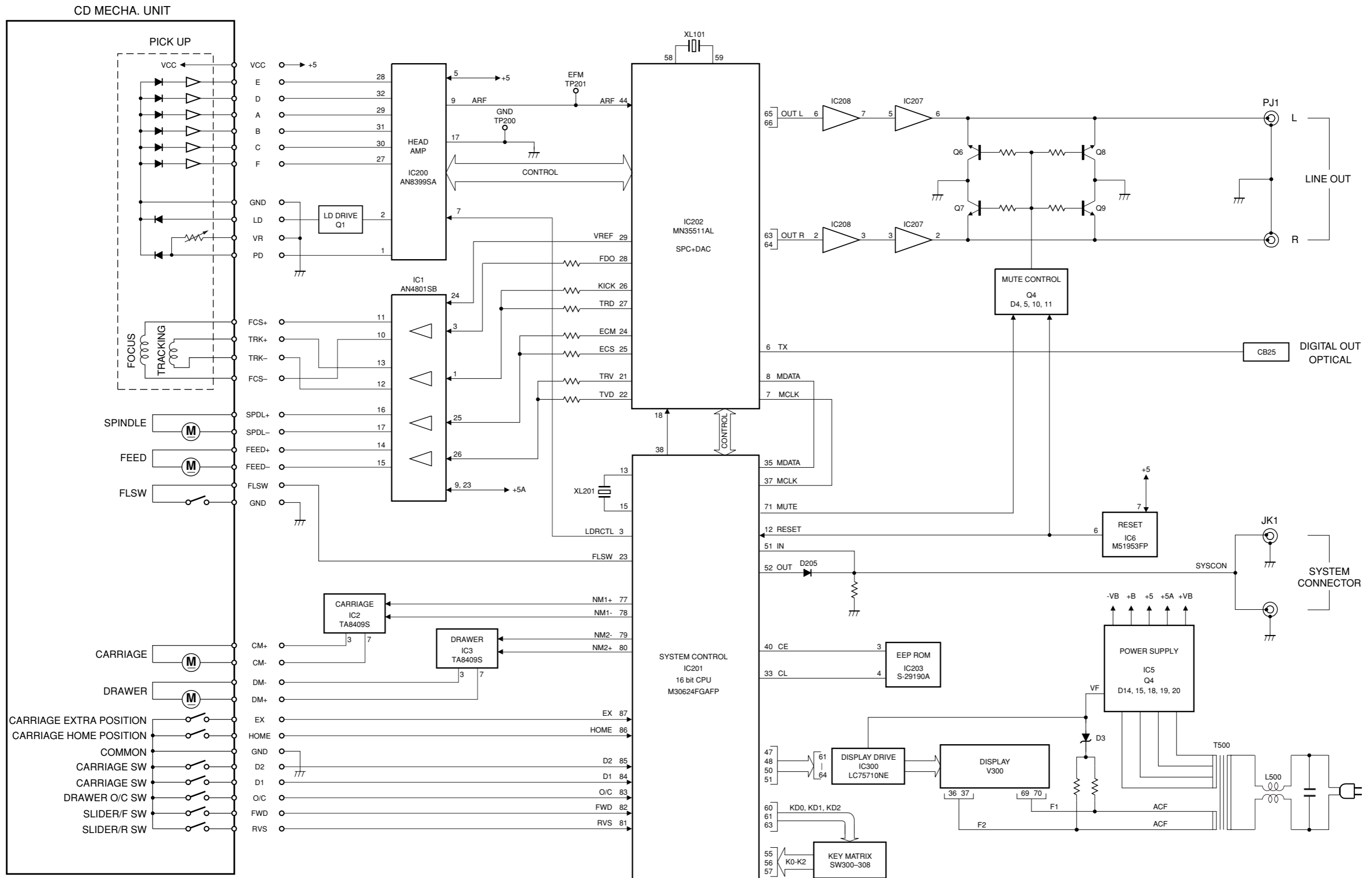

• Semiconductor Location

Ref. No.	Location
D200	H6
D201	H6
D202	H6
D203	H6
D204	H6
D205	G7
D206	H6
IC200	B6
IC201	G6
IC202	E6
IC203	F6
IC207	C7
IC208	D7

■ PRINTED CIRCUIT BOARD (Foil side)

MAIN (1) P. C. B. (Lead Type Device)

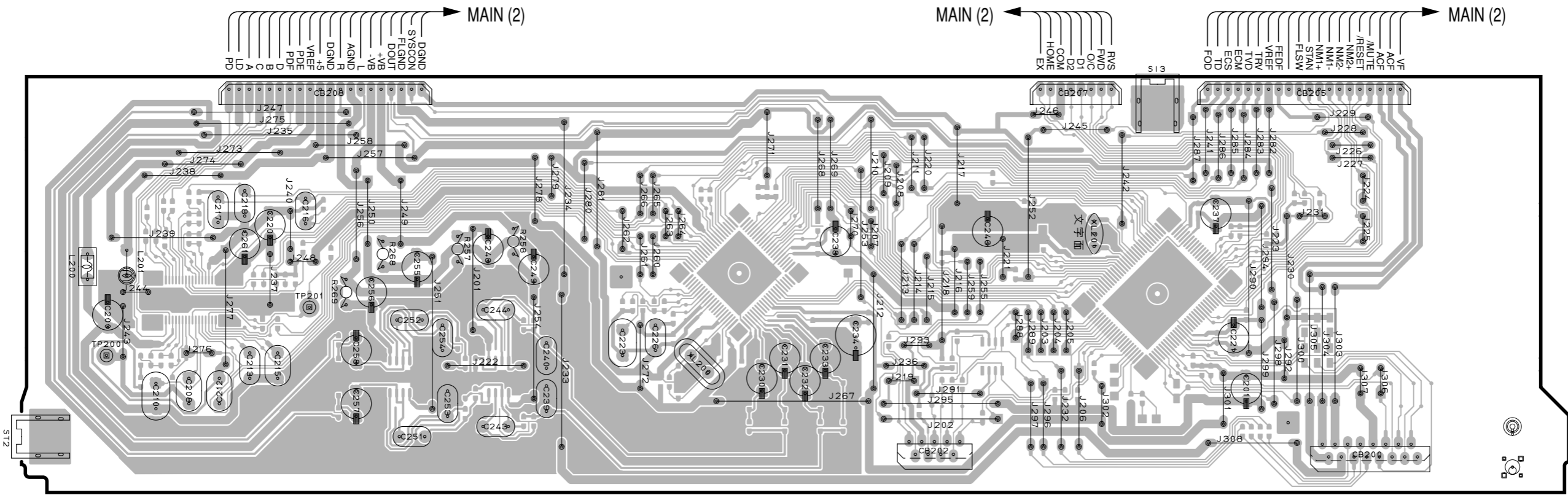

MAIN (1) P. C. B. (Surface Mount Device)

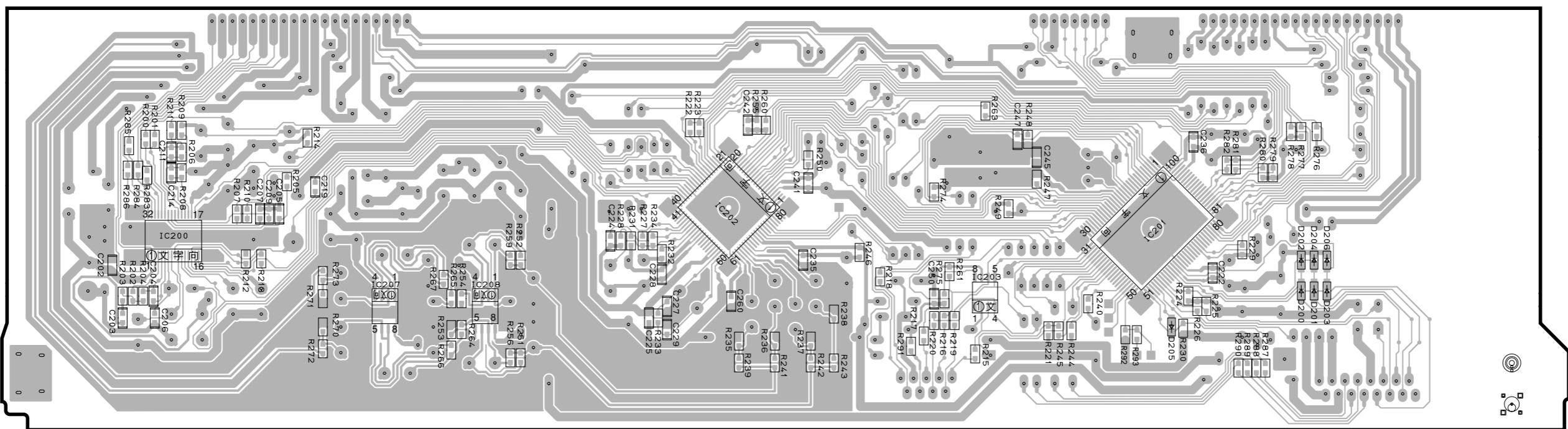



1

■ PRINTED CIRCUIT BOARD (Foil side)

• Semiconductor Location

Ref. No.	Location
IC300	G6

MAIN (3) P. C. B. (Lead Type Device)

MAIN (5) P. C. B. (Lead Type Device)

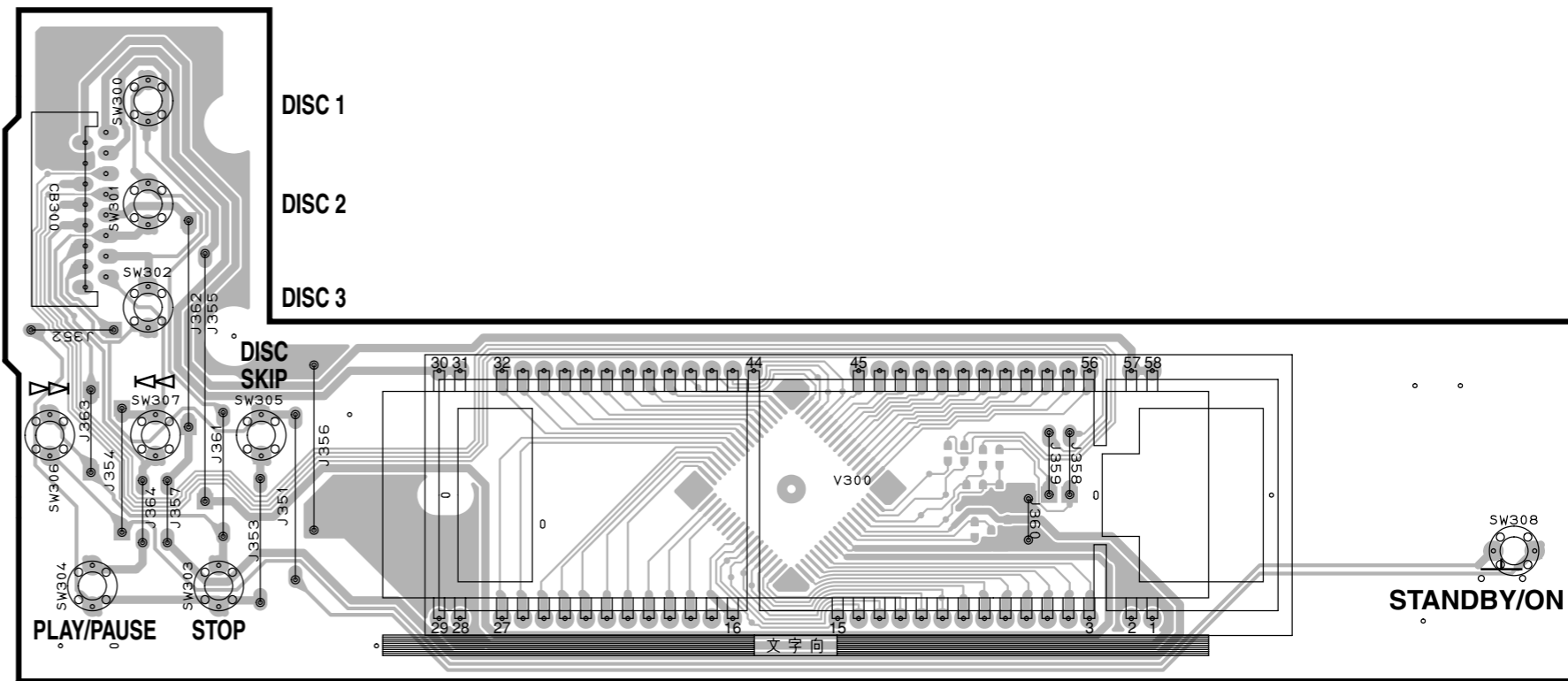
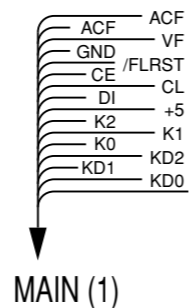
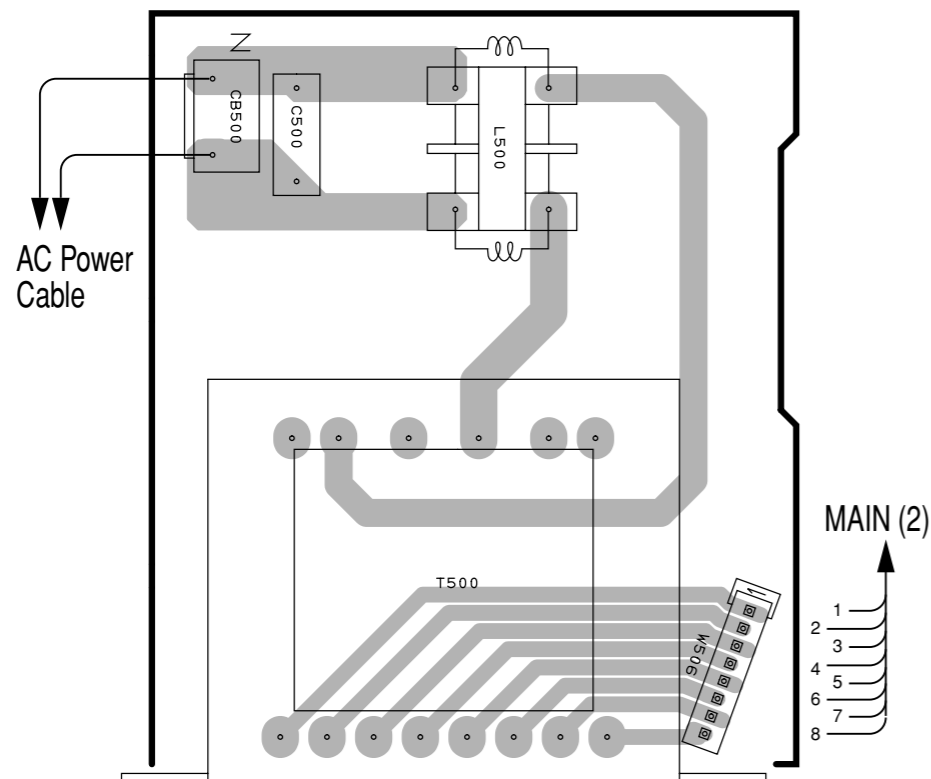

MAIN (5) P. C. B. (Surface Mount Device)

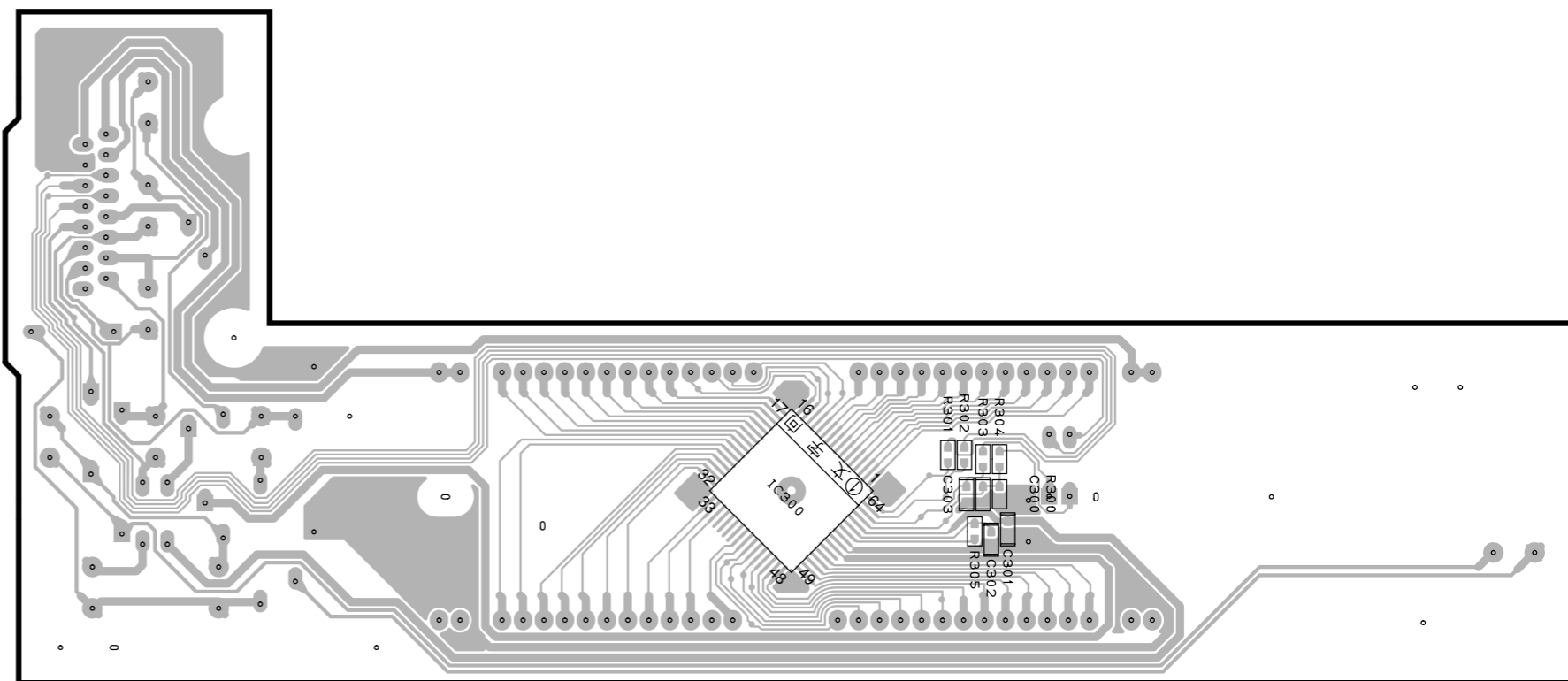

4

5

6

7

# IC BLOCK

IC1: AN4801SB-E1  
4-Channel Power OP-Amp System Driver

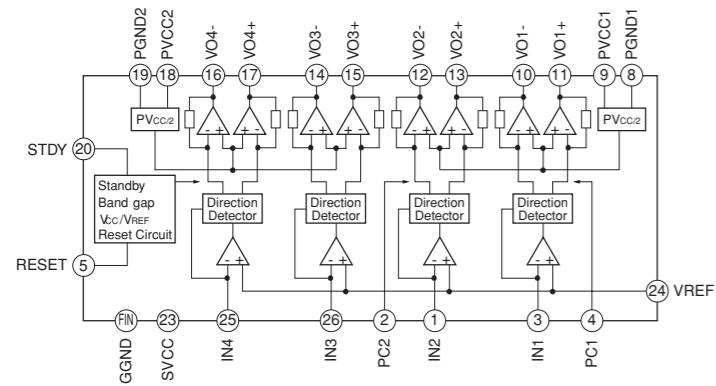

IC2, 3: TA8409SE  
Full Bridge Motor Driver

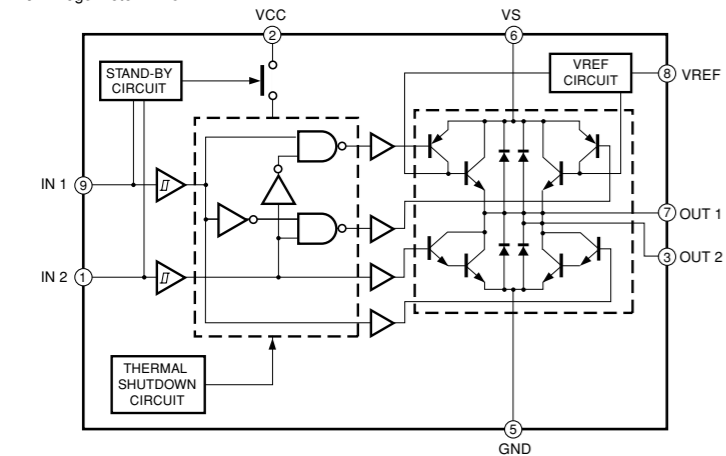

INPUT (Note)		OUTPUT		MODE (MOTOR)
IN 1	IN 2	OUT 1	OUT 2	
0	0	∞	∞	STOP
1	0	H	L	CW/CCW
0	1	L	H	CCW/CW
1	1	L	L	BRAEK

IC5: NJM78M05FA  
Voltage Regulator

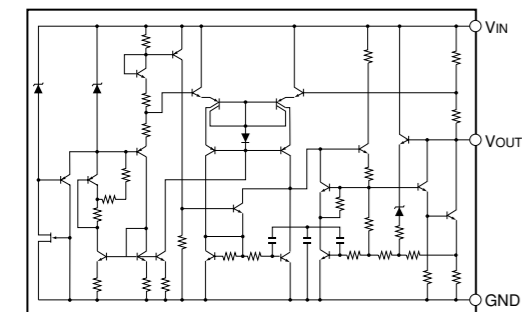

IC6 : M51953BFP  
System Reset

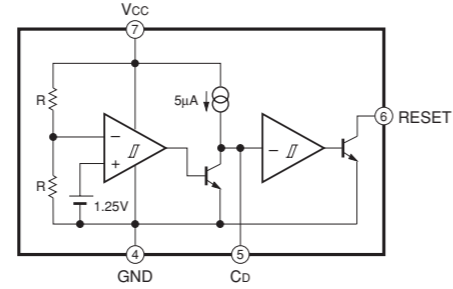

IC200: AN8399SA-E1  
CD Head Amp.

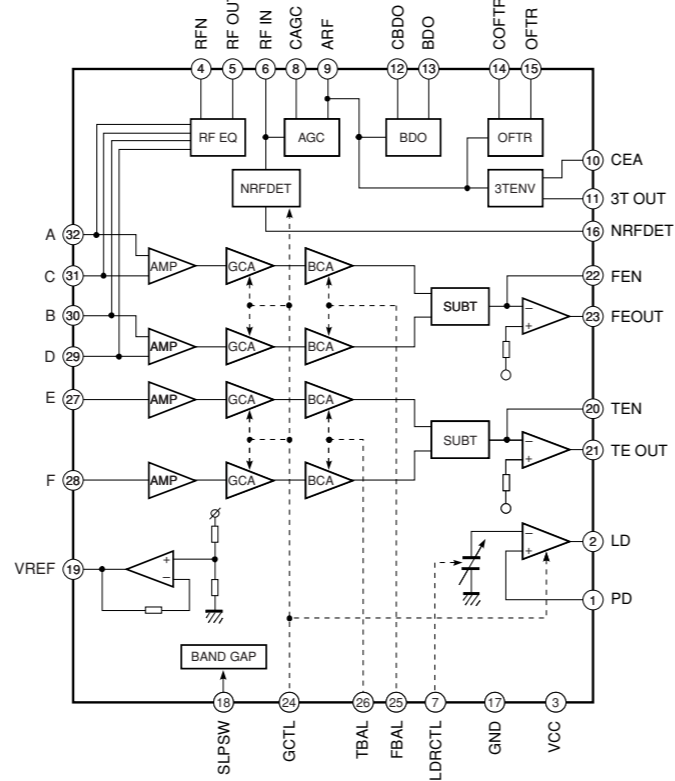

IC203 : S-29190AFJA  
CMOS 1kbit EEPROM

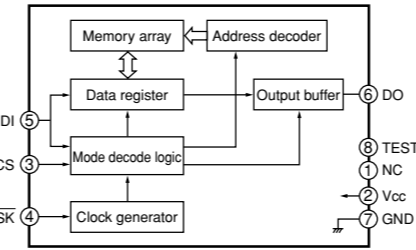

IC207, 208: NJM2068MD  
Dual OP-Amp.

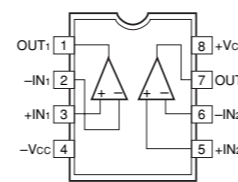

IC300: LC75710NE  
FL Display Driver

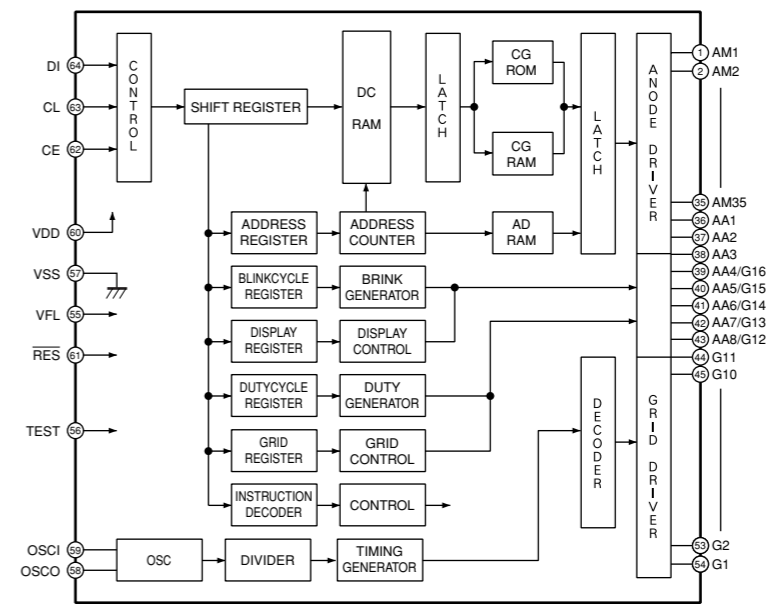

## PIN CONNECTION DIAGRAM

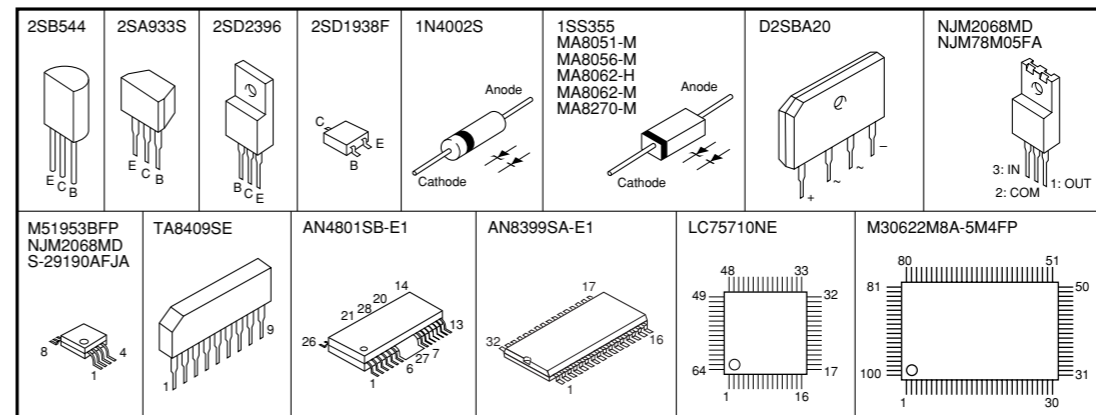

SCHEMATIC DIAGRAM

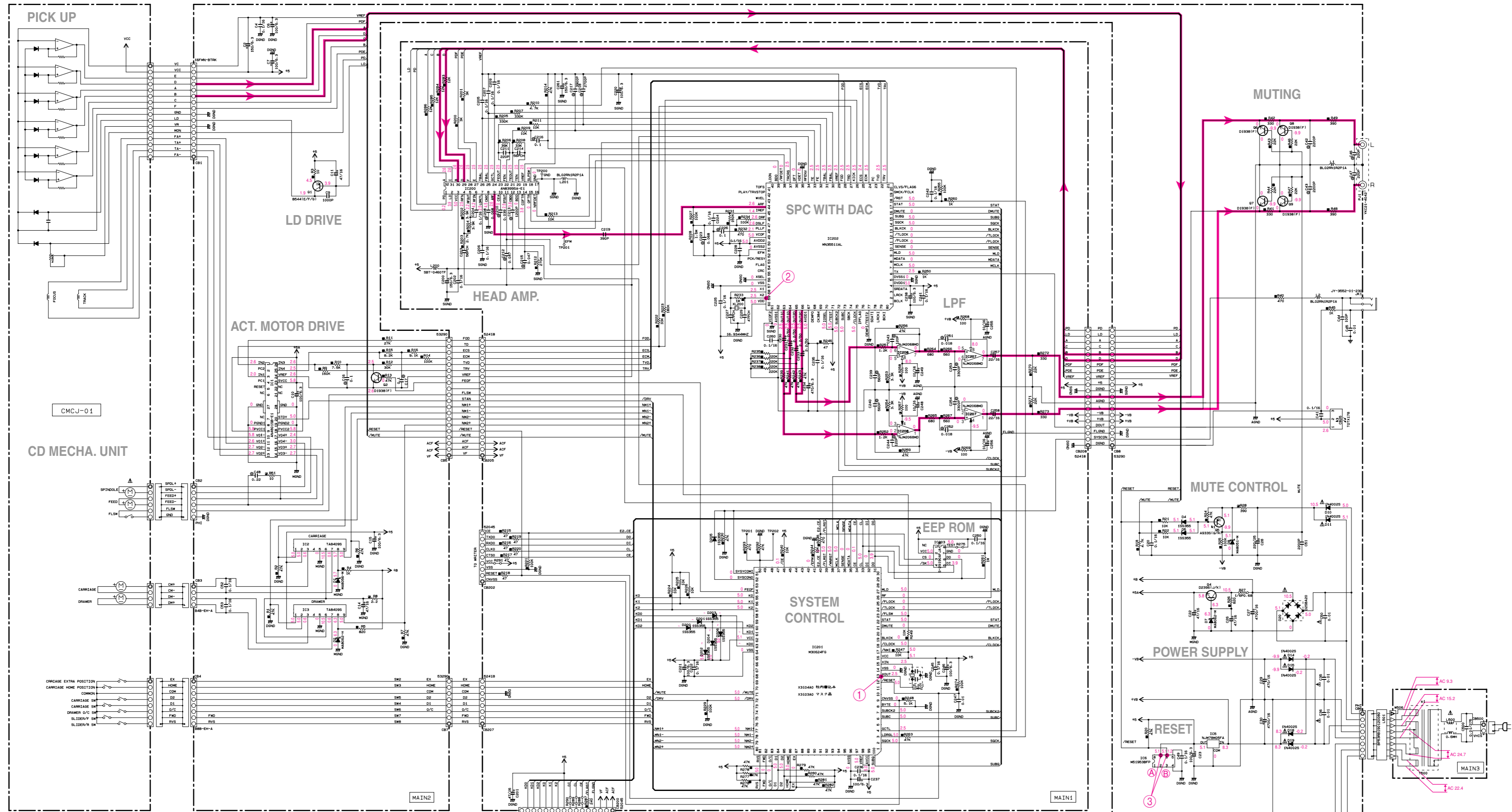

CAPACITOR	REMARKS	PARTS NAME
NO MARK ELECTROLYTIC CAPACITOR		
NO MARK TANTALUM CAPACITOR		
NO MARK CERAMIC CAPACITOR		
CERAMIC TUBULAR CAPACITOR		
POLYESTER FILM CAPACITOR		
POLYETHYLENE FILM CAPACITOR		
MICA CAPACITOR		
POLYPROPYLENE FILM CAPACITOR		
SEMICONDUCTIVE CERAMIC CAPACITOR		

RESISTOR	REMARKS	PARTS NAME
NO MARK CARBON FILM RESISTOR (P=10)		
CARBON FILM RESISTOR (P=10)		
METAL OXIDE FILM RESISTOR		
METAL FILM RESISTOR		
METAL PLATE RESISTOR		
FIRE PROOF CARBON FILM RESISTOR		
CEMENT MOUNTED RESISTOR		
SEMI-VARIABLE RESISTOR		
OHMIC RESISTOR		

NOTICE (code):  
 (J) JAPAN  
 (U) U.S.A.  
 (C) CANADA  
 (G) GENERAL  
 (T) CHINA  
 (K) KOREA  
 (A) AUSTRALIA  
 (B) BRITISH  
 (E) EUROPE  
 (L) SINGAPORE

Interchangeable Parts at Manufacture Stage	Mark	Reference Parts Number	Parts Name
	11	03 08	25483010/P1 25411001/P1 25413001(P/S)
	13	0805	1074176 1074176A

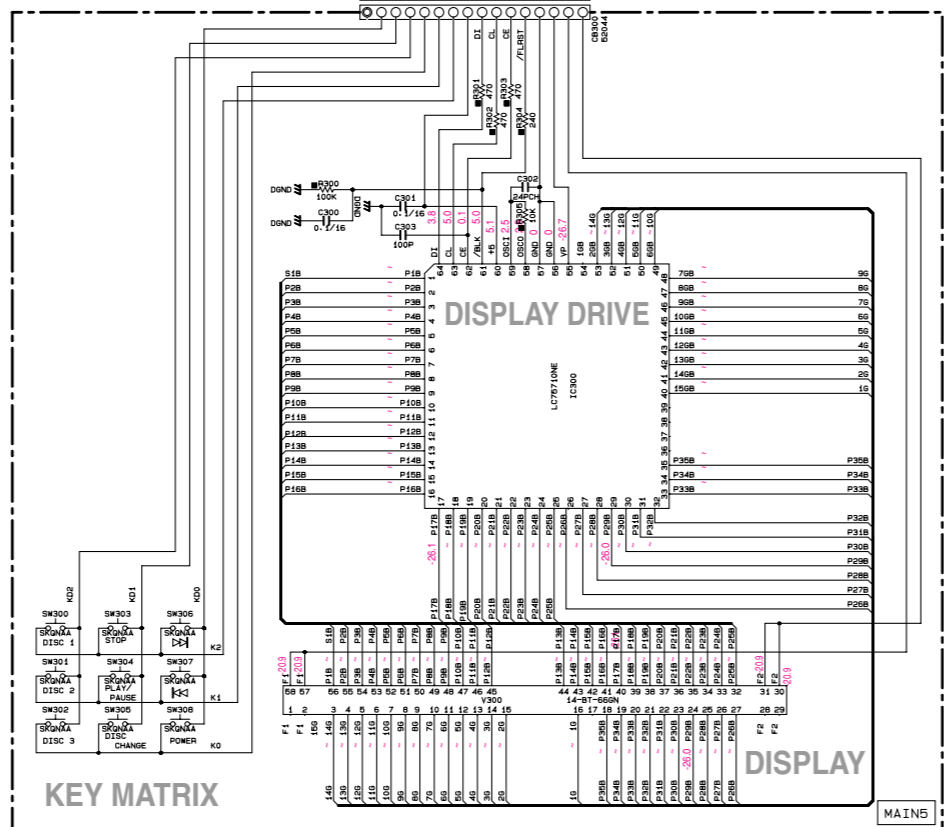

- ★ All voltage are measured with a 10MΩ/V DC electric volt meter.
- ★ Components having special characteristics are marked  $\Delta$  and must be replaced with parts having specifications equal to those originally installed.
- ★ Schematic diagram is subject to change without notice.

Point ① Pin 13 of IC201

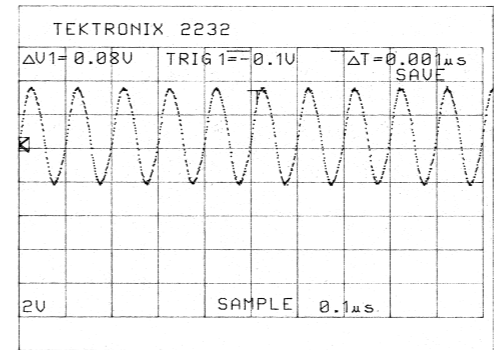

Point ② Pin 59 of IC202

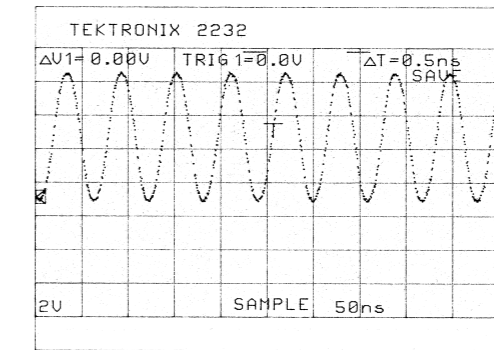

Point ③ Pin 7 of IC6 and Pin 6 of IC6

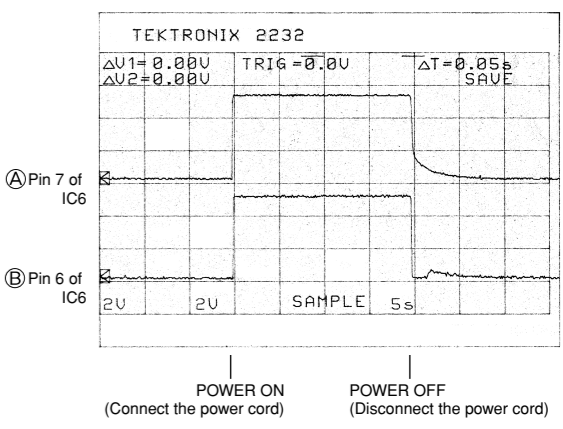

x: NOT USED  
 O: USED / APPLICABLE

# PARTS LIST

## ■ ELECTRICAL PARTS

### ■ WARNING

Components having special characteristics are marked  $\triangle$  and must be replaced with parts having specifications equal to those originally installed.

### ABBREVIATIONS IN THIS LIST ARE AS FOLLOWS:

C.A.EL.CHP	: CHIP ALUMI.ELECTROLYTIC CAP	L.EMIT	: LIGHT EMITTING MODULE
C.CE	: CERAMIC CAP	LED.DSPLY	: LED DISPLAY
C.CE.ARRAY	: CERAMIC CAP ARRAY	LED.INFRD	: LED,INFRARED
C.CE.CHP	: CHIP CERAMIC CAP	MODUL.RF	: MODULATOR,RF
C.CE.ML	: MULTILAYER CERAMIC CAP	PHOT.CPL	: PHOTO COUPLER
C.CE.M.CHP	: CHIP MULTILAYER CERAMIC CAP	PHOT.INTR	: PHOTO INTERRUPTER
C.CE.SAFTY	: RECOGNIZED CERAMIC CAP	PHOT.RFLCT	: PHOTO REFLECTOR
C.CE.TUBLR	: CERAMIC TUBULAR CAP	PIN.TEST	: PIN,TEST POINT
C.CE.SMI	: SEMI CONDUCTIVE CERAMIC CAP	PLST.RIVET	: PLASTIC RIVET
C.EL	: ELECTROLYTIC CAP	R.ARRAY	: RESISTOR ARRAY
C.MICA	: MICA CAP	R.CAR.	: CARBON RESISTOR
C.ML.FLM	: MULTILAYER FILM CAP	R.CAR.CHP	: CHIP RESISTOR
C.MP	: METALLIZED PAPER CAP	R.CAR.FP	: FLAME PROOF CARBON RESISTOR
C.MYLAR	: MYLAR FILM CAP	R.FUS	: FUSABLE RESISTOR
C.MYLAR.ML	: MULTILAYER MYLAR FILM CAP	R.MTL.CHP	: CHIP METAL FILM RESISTOR
C.PAPER	: PAPER CAPACITOR	R.MTL.FLM	: METAL FILM RESISTOR
C.PLS	: POLYSTYRENE FILM CAP	R.MTL.OXD	: METAL OXIDE FILM RESISTOR
C.POL	: POLYESTER FILM CAP	R.MTL.PLAT	: METAL PLATE RESISTOR
C.POLY	: POLYETHYLENE FILM CAP	RSNR.CE	: CERAMIC RESONATOR
C.PP	: POLYPROPYLENE FILM CAP	RSNR.CRYS	: CRYSTAL RESONATOR
C.TNTL	: TANTALUM CAP	R.TW.CEM	: TWIN CEMENT FIXED RESISTOR
C.TNTL.CHP	: CHIP TANTALUM CAP	R.WW	: WIRE WOUND RESISTOR
C.TRIM	: TRIMMER CAP	SCR.BND.HD	: BIND HEAD B-TITE SCREW
CN	: CONNECTOR	SCR.BW.HD	: BW HEAD TAPPING SCREW
CN.BS.PIN	: CONNECTOR,BASE PIN	SCR.CUP	: CUP TITE SCREW
CN.CANNON	: CONNECTOR,CANNON	SCR.TERM	: SCREW TERMINAL
CN.DIN	: CONNECTOR,DIN	SCR.TR	: SCREW,TRANSISTOR
CN.FLAT	: CONNECTOR,FLAT CABLE	SUPRT.PCB	: SUPPORT,P.C.B.
CN.POST	: CONNECTOR,BASE POST	SURG.PRTCT	: SURGE PROTECTOR
COIL.MX.AM	: COIL,AM MIX	SW.TACT	: TACT SWITCH
COIL.AT.FM	: COIL,FM ANTENNA	SW.LEAF	: LEAF SWITCH
COIL.DT.FM	: COIL,FM DETECT	SW.LEVER	: LEVER SWITCH
COIL.MX.FM	: COIL,FM MIX	SW.MICRO	: MICRO SWITCH
COIL.OUTPT	: OUTPUT COIL	SW.PUSH	: PUSH SWITCH
DIOD.ARRAY	: DIODE ARRAY	SW.RT.ENC	: ROTARY ENCODER
DIODE.BRG	: DIODE BRIDGE	SW.RT.MTR	: ROTARY SWITCH WITH MOTOR
DIODE.CHP	: CHIP DIODE	SW.RT	: ROTARY SWITCH
DIODE.SHOT	: SCHOTTKY BARRIER DIODE	SW.SLIDE	: SLIDE SWITCH
DIODE.VAR	: VARACTOR DIODE	TERM.SP	: SPEAKER TERMINAL
DIOD.Z.CHP	: CHIP ZENER DIODE	TERM.WRAP	: WRAPPING TERMINAL
DIODE.ZENR	: ZENER DIODE	THRMST.CHP	: CHIP THERMISTOR
DSCR.CE	: CERAMIC DISCRIMINATOR	TR.CHP	: CHIP TRANSISTOR
FER.BEAD	: FERRITE BEADS	TR.DGT	: DIGITAL TRANSISTOR
FER.CORE	: FERRITE CORE	TR.DGT.CHP	: CHIP DIGITAL TRANSISTOR
FET.CHP	: CHIP FET	TRANS	: TRANSFORMER
FL.DSPLY	: FLUORESCENT DISPLAY	TRANS.PULS	: PULSE TRANSFORMER
FLTR.CE	: CERAMIC FILTER	TRANS.PWR	: POWER TRANSFORMER ASS'Y
FLTR.COMB	: COMB FILTER MODULE	TUNER.AM	: TUNER PACK,AM
FLTR.LC.RF	: LC FILTER,EMI	TUNER.FM	: TUNER PACK,FM
GND.MTL	: GROUND PLATE	TUNER.PK	: FRONT-END TUNER PACK
GND.TERM	: GROUND TERMINAL	VR	: ROTARY POTENTIOMETER
HOLDER.FUS	: FUSE HOLDER	VR.MTR	: POTENTIOMETER WITH MOTOR
IC.PRTCT	: IC PROTECTOR	VR.SW	: POTENTIOMETER WITH ROTARY SW
JUMPER.CN	: JUMPER CONNECTOR	VR.SLIDE	: SLIDE POTENTIOMETER
JUMPER.TST	: JUMPER,TEST POINT	VR.TRIM	: TRIMMER POTENTIOMETER
L.DTCT	: LIGHT DETECTING MODULE		

**Note)** Those parts marked with “#” are not included in the P.C.B. ass'y.



**! : Note on the Main P.C.B.**

Of the main P.C.B. part Nos., only the gold (GD) type part Nos. are included in the table.

The only different part between the silver (SI) and gold (GD) type parts is the sheet/FL that is attached to the fluorescent character display tube. When a SI type main P.C.B. becomes necessary, order a GD type main P.C.B. and a SI type sheet/FL (V3688400) and replace the sheet/FL of the GD type main P.C.B. with the SI type sheet/FL.

**P.C.B. MAIN**

Schm Ref.	PART NO.	Description		Markets
	V9646000	P. C. B.	GD:MAIN	UC
	V9646100	P. C. B.	GD:MAIN	A
CB1	V2731000	CN. FMN	16P	
CB2	VB390200	CN. BS. PIN	6P	
CB3	V7534600	CN. BS. PIN	4P TE	
CB4	V7534700	CN. BS. PIN	8P TE	
CB5	VQ964100	CN. BS. PIN	20P	
CB6	VB390400	CN. BS. PIN	8P	
CB7	VQ962900	CN. BS. PIN	8P	
CB8	VQ964100	CN. BS. PIN	20P	
CB25	VT707200	L. EMIT	TOTX178	
CB200	VM859700	CN. BS. PIN	16P	
CB202	VQ047200	CN. BS. PIN	9P	
CB205	VQ962300	CN. BS. PIN	20P	
CB207	VQ961100	CN. BS. PIN	8P	
CB208	VQ962300	CN. BS. PIN	20P	
CB300	VQ044700	CN. BS. PIN	16P	
CB500	VG879900	CN. BS. PIN	2P	
C2	V4749000	C. EL	150uF 6.3V	
C4	US135100	C. CE. CHP	0.1uF 16V	
C6	UR818100	C. EL	100uF 6.3V	
C7	UR818100	C. EL	100uF 6.3V	
C9	US063100	C. CE. M. CHP	1000pF 50V	
C10	UR818100	C. EL	100uF 6.3V	
C11	UR837470	C. EL	47uF 16V	
C14	UR837470	C. EL	47uF 16V	
C15	UR818100	C. EL	100uF 6.3V	
C16	VE326000	C. MYLAR. ML	0.1uF 50V	
C17	VE326000	C. MYLAR. ML	0.1uF 50V	
C18	UR866470	C. EL	4.7uF 50V	
C19	UR866470	C. EL	4.7uF 50V	
C20	US135100	C. CE. CHP	0.1uF 16V	
C21	UR866470	C. EL	4.7uF 50V	
C22	UR837470	C. EL	47uF 16V	
C23	UR818100	C. EL	100uF 6.3V	
C24	UR866470	C. EL	4.7uF 50V	
C25	UR868100	C. EL	100uF 50V	
C26	UR837470	C. EL	47uF 16V	
C27	UR739470	C. EL	4700uF 16V	
C28	UR848220	C. EL	220uF 25V	
C29	UR838470	C. EL	470uF 16V	
C30	UR739470	C. EL	4700uF 16V	
C35	FG644100	C. CE	0.01uF 50V	
C36	FG644100	C. CE	0.01uF 50V	
C41	US135100	C. CE. CHP	0.1uF 16V	
C42	UA653220	C. MYLAR	2200pF 50V	
C43	UA653220	C. MYLAR	2200pF 50V	
C44	US062100	C. CE. M. CHP	100pF 50V	
C45	US064100	C. CE. M. CHP	0.01uF 50V	
C46	UA652220	C. MYLAR	220pF 50V	
C47	UA652220	C. MYLAR	220pF 50V	
C48	VE326400	C. MYLAR. ML	0.22uF 50V	
C49	US135100	C. CE. CHP	0.1uF 16V	
C50	FG644100	C. CE	0.01uF 50V	
C51	US063220	C. CE. M. CHP	2200pF 50V	
C52	US135100	C. CE. CHP	0.1uF 16V	
C53	US135100	C. CE. CHP	0.1uF 16V	
C200	V4749000	C. EL	150uF 6.3V	
C201	UR837470	C. EL	47uF 16V	

Schm Ref.	PART NO.	Description		Markets
C202	US135100	C. CE. CHP	0.1uF 16V	
C203	US061560	C. CE. CHP	56pF 50V	
C204	US135100	C. CE. CHP	0.1uF 16V	
C205	US135100	C. CE. CHP	0.1uF 16V	
C206	US135100	C. CE. CHP	0.1uF 16V	
C207	US135100	C. CE. CHP	0.1uF 16V	
C208	UA654680	C. MYLAR	0.068uF 50V	
C209	US135100	C. CE. CHP	0.1uF 16V	
C210	UA654390	C. MYLAR	0.039uF 50V	
C211	US062220	C. CE. CHP	220pF 50V	
C212	UA654470	C. MYLAR	0.047uF 50V	
C213	UA653120	C. MYLAR	1200pF 50V	
C214	US061560	C. CE. CHP	56pF 50V	
C215	UA654470	C. MYLAR	0.047uF 50V	
C216	VE326000	C. MYLAR. ML	0.1uF 50V	
C217	UA653390	C. MYLAR	3900pF 50V	
C218	UA653270	C. MYLAR	2700pF 50V	
C219	US062390	C. CE. CHP	390P 50V	
C220	UR818100	C. EL	100uF 6.3V	
C221	UR818100	C. EL	100uF 6.3V	
C222	US135100	C. CE. CHP	0.1uF 16V	
C223	UA654680	C. MYLAR	0.068uF 50V	
C224	US135100	C. CE. CHP	0.1uF 16V	
C225	US135100	C. CE. CHP	0.1uF 16V	
C226	VE326000	C. MYLAR. ML	0.1uF 50V	
C227	US061470	C. CE. M. CHP	47pF 50V	
C228	US135100	C. CE. CHP	0.1uF 16V	
C229	US061470	C. CE. M. CHP	47pF 50V	
C230	VG290600	C. EL	2.2uF 50V	
C231	VG290600	C. EL	2.2uF 50V	
C232	VG290600	C. EL	2.2uF 50V	
C233	VG290600	C. EL	2.2uF 50V	
C234	VG286500	C. EL	470uF 10V	
C235	US135100	C. CE. CHP	0.1uF 16V	
C236	US135100	C. CE. CHP	0.1uF 16V	
C237	UR818100	C. EL	100uF 6.3V	
C238	UR818100	C. EL	100uF 6.3V	
C239	UA652560	C. MYLAR	560pF 50V	
C240	UA652560	C. MYLAR	560pF 50V	
C241	US135100	C. CE. CHP	0.1uF 16V	
C242	US135100	C. CE. CHP	0.1uF 16V	
C243	UA652120	C. MYLAR	120pF 50V	
C244	UA652120	C. MYLAR	120pF 50V	
C245	US135100	C. CE. CHP	0.1uF 16V	
C246	UR818100	C. EL	100uF 6.3V	
C247	US064100	C. CE. M. CHP	0.01uF 50V	
C248	UR837100	C. EL	10uF 16V	
C249	UR837100	C. EL	10uF 16V	
C250	US135100	C. CE. CHP	0.1uF 16V	
C251	UA654180	C. MYLAR	0.018uF 50V	
C252	UA654180	C. MYLAR	0.018uF 50V	
C253	UA653330	C. MYLAR	3300pF 50V	
C254	UA653330	C. MYLAR	3300pF 50V	
C255	UR837100	C. EL	10uF 16V	
C256	UR837100	C. EL	10uF 16V	
C257	VG287300	C. EL	22uF 50V	
C258	VG287300	C. EL	22uF 50V	
C260	US135100	C. CE. CHP	0.1uF 16V	
C261	V4749000	C. EL	150uF 6.3V	

\* New Parts

\* New Parts

**P.C.B. MAIN**

**Chip Resistors**

Schm Ref.	PART NO.	Description	Markets	Schm Ref.	PART NO.	Description	Markets
C300	US135100	C. CE. CHP	0. 1uF 16V	R23	HV756220	R. CAR. FP	2. 2KΩ 1/4W
C301	US135100	C. CE. CHP	0. 1uF 16V	R27	V1868300	R. FUS	0. 68Ω 1/6W
C302	US061240	C. CE. CHP	24pF 50V	R28	HV755390	R. CAR. FP	390Ω 1/4W
C303	US062100	C. CE. M. CHP	100pF 50V	R50	HV753330	R. CAR. FP	3. 3Ω 1/4W
C500	V6185300	C. CE. SAFTY	0. 01uF 275V	R51	HV754100	R. CAR. FP	10Ω 1/4W
D1	VU993000	DIODE. ZENR	MA8056-M 5. 6V	R257	HV755100	R. CAR. FP	100Ω 1/4W
D2	VU993500	DIODE. ZENR	MA8062-H 6. 4V	R258	HV755100	R. CAR. FP	100Ω 1/4W
D3	VU993000	DIODE. ZENR	MA8056-M 5. 6V	R268	HV755100	R. CAR. FP	100Ω 1/4W
D4	VT332900	DIODE	1SS355	R269	HV755100	R. CAR. FP	100Ω 1/4W
D5	VT332900	DIODE	1SS355	ST2	V4040500	SCR. TERM	M3
D6	VU999500	DIODE. ZENR	MA8270-M 27V	ST3	V4040500	SCR. TERM	M3
D7	VU993400	DIODE. ZENR	MA8062-M 6. 2V	SW300	VV020300	SW. TACT	SKQNAA
D8	VU992600	DIODE. ZENR	MA8051-M 5. 1V	SW301	VV020300	SW. TACT	SKQNAA
D9	VV307700	DIODE	1N4002S	SW302	VV020300	SW. TACT	SKQNAA
D10	VV307700	DIODE	1N4002S	SW303	VV020300	SW. TACT	SKQNAA
D11	VV307700	DIODE	1N4002S	SW304	VV020300	SW. TACT	SKQNAA
D14	VV307700	DIODE	1N4002S	SW305	VV020300	SW. TACT	SKQNAA
D15	VV307700	DIODE	1N4002S	SW306	VV020300	SW. TACT	SKQNAA
D18	VV307700	DIODE	1N4002S	SW307	VV020300	SW. TACT	SKQNAA
D19	VV307700	DIODE	1N4002S	SW308	VV020300	SW. TACT	SKQNAA
D20	V4269600	DIODE. BRG	D2SBA20 1.5A 200V	T500	X0138A00	TRANS. PWR	UC
D200	VT332900	DIODE	1SS355	T500	X0140A00	TRANS. PWR	A
D201	VT332900	DIODE	1SS355	TP200	VT969000	PIN. TEST	IRS-2049
D202	VT332900	DIODE	1SS355	TP201	VT969000	PIN. TEST	IRS-2049
D203	VT332900	DIODE	1SS355	V300	V6951300	FL. DSPLY	14-BT-66GN
D204	VT332900	DIODE	1SS355	XL200	VJ719800	RSNR. CRYST	16. 9344MHz
D205	VT332900	DIODE	1SS355	XL201	V8222200	RSNR. CE	CSTLS10MOG53-A0
D206	VT332900	DIODE	1SS355		V3747500	SUPRT	
IC1	X0070A00	IC	AN4801SB-E1		V3747400	SPACER. FL	T4x6x18
IC2	XR274A00	IC	TA8409SE		VQ948800	SHEET. FL	GD
IC3	XR274A00	IC	TA8409SE	!	V3688400	SHEET. FL	SI
IC5	XJ604A00	IC	NJM78M05FA				
IC6	XP157A00	IC	M51953BFP				
IC200	X0071A00	IC	AN8399SA-E1				
IC201	X3103A00	IC	M30622M8A-5M4FP				
IC202	XW915A00	IC	MN35511AL				
IC203	XV953A00	IC	S-29190AFJA EEPROM				
IC207	X3505A00	IC	NJM2068MD-TE2				
IC208	X3505A00	IC	NJM2068MD-TE2				
IC300	XR188A00	IC	LC75710NE FLD				
JK1	V3576300	JACK	2P				
L1	VP133800	FER. BEAD	BL02RN1-R62T4				
L2	VP133800	FER. BEAD	BL02RN1-R62T4				
L200	VD473700	COIL	60uH				
L201	VP133800	FER. BEAD	BL02RN1-R62T4				
L500	VU984000	FLTR	1E-UU10. 5-009				
L501	Vi491100	FER. CORE	BP53RB19012080M				
PJ1	V4925100	JACK. PIN	2P				
PN1	V8637500	PIN	L=50 #18				
PN2	V8637500	PIN	L=50 #18				
PN3	V8637500	PIN	L=50 #18				
Q1	iB054430	TR	2SB544 D, E, F, G				
Q2	VZ725900	TR	2SD1938F S, T				
Q3	iA093320	TR	2SA933S Q, R				
Q4	VR510800	TR	2SD2396 J, K				
Q5	iA093320	TR	2SA933S Q, R				
Q6	VZ725900	TR	2SD1938F S, T				
Q7	VZ725900	TR	2SD1938F S, T				
Q8	VZ725900	TR	2SD1938F S, T				
Q9	VZ725900	TR	2SD1938F S, T				
R8	HV753220	R. CAR. FP	2. 2Ω 1/4W				
R17	HV755100	R. CAR. FP	100Ω 1/4W				
R19	HV755100	R. CAR. FP	100Ω 1/4W				

\* New Parts

\* New Parts

Schm Ref.	PART NO.	Description	Markets	Schm Ref.	PART NO.	Description	Markets
	RD350000	R. CAR. CHP	0Ω 1/10W				
	RD354100	R. CAR. CHP	10Ω 1/10W				
	RD354470	R. CAR. CHP	47Ω 1/10W				
	RD355240	R. CAR. CHP	240Ω 1/10W				
	RD355330	R. CAR. CHP	330Ω 1/10W				
	RD355390	R. CAR. CHP	390Ω 1/10W				
	RD355470	R. CAR. CHP	470Ω 1/10W				
	RD355560	R. CAR. CHP	560Ω 1/10W				
	RD355680	R. CAR. CHP	680Ω 1/10W				
	RD355820	R. CAR. CHP	820Ω 1/10W				
	RD356100	R. CAR. CHP	1KΩ 1/10W				
	RD356120	R. CAR. CHP	1. 2KΩ 1/10W				
	RD356270	R. CAR. CHP	2. 7KΩ 1/10W				
	RD356300	R. CAR. CHP	3KΩ 1/10W				
	RD356330	R. CAR. CHP	3. 3KΩ 1/10W				
	RD356390	R. CAR. CHP	3. 9KΩ 1/10W				
	RD356470	R. CAR. CHP	4. 7KΩ 1/10W				
	RD356510	R. CAR. CHP	5. 1KΩ 1/10W				
	RD356750	R. CAR. CHP	7. 5KΩ 1/10W				
	RD356820	R. CAR. CHP	8. 2KΩ 1/10W				
	RD356910	R. CAR. CHP	9. 1KΩ 1/10W				
	RD357100	R. CAR. CHP	10KΩ 1/10W				
	RD357120	R. CAR. CHP	12KΩ 1/10W				
	RD357220	R. CAR. CHP	22KΩ 1/10W				
	RD357270	R. CAR. CHP	27KΩ 1/10W				
	RD357300	R. CAR. CHP	30KΩ 1/10W				
	RD357330	R. CAR. CHP	33KΩ 1/10W				
	RD357390	R. CAR. CHP	39KΩ 1/10W				
	RD357470	R. CAR. CHP	47KΩ 1/10W				
	RD358100	R. CAR. CHP	100KΩ 1/10W				
	RD358150	R. CAR. CHP	150KΩ 1/10W				
	RD358160	R. CAR. CHP	160KΩ 1/10W				
	RD358180	R. CAR. CHP	180KΩ 1/10W				
	RD358220	R. CAR. CHP	220KΩ 1/10W				
	RD358270	R. CAR. CHP	270KΩ 1/16W				
	RD358330	R. CAR. CHP	330KΩ 1/10W				
	RD359100	R. CAR. CHP	1MΩ 1/10W				
	RD359150	R. CAR. CHP	1. 5MΩ 1/10W				
	RF457470	R. CAR. CHP	47KΩ 1/10W				

\* New Parts

\* New Parts

EXPLODED VIEW

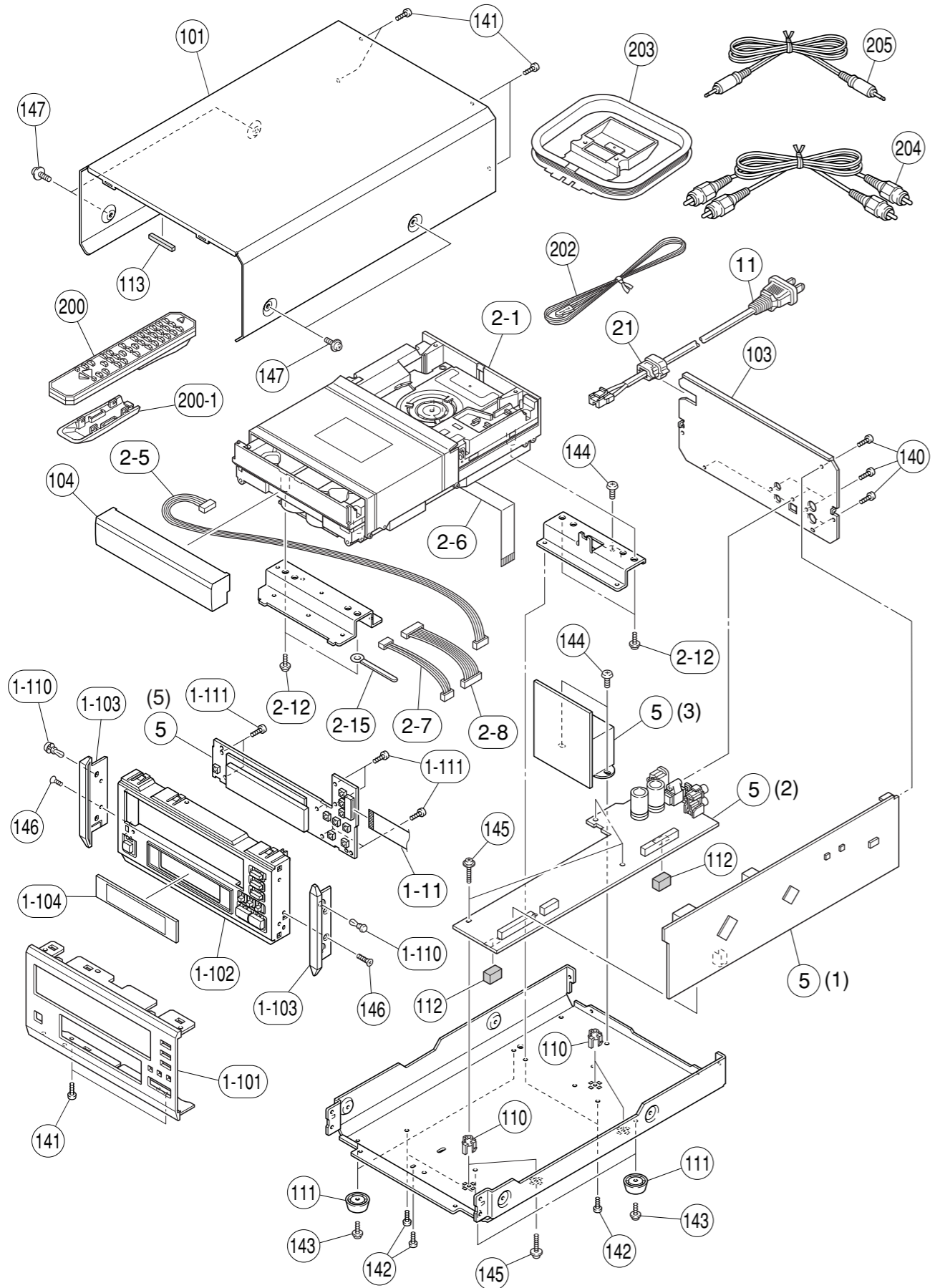

MECHANICAL PARTS

Ref. No.	PART NO.	Description	Remarks	Markets
1-11	MF116160	FLEXIBLE FLAT CABLE	16P 160mm P=1.25	
* 1-101	V9046900	FRONT PANEL		GD
* 1-101	V9047000	FRONT PANEL		SI
* 1-102	V9047300	SUB PANEL-CDC		GD
* 1-102	V9047400	SUB PANEL-CDC		SI
* 1-103	V8785200	PANEL/SIDE	H100	
* 1-104	V8782600	SHEET		
1-110	VQ368600	PUSH RIVET	P3555-B	
1-111	VF617600	PAN HEAD P-TITE SCREW	2.6x8 MFC2BL	
2-1	V7527900	CDC MECHANISM UNIT	CMCJ0125	
2-5	MF506400	CRIMPING ASS'Y	6P 400mm C&C	
2-6	V2017700	CONNECTOR, FLAT CABLE	16P 280mm	
2-7	V7716600	CONNECTOR ASS'Y	4P 200mm C&C	
2-8	V7636300	CONNECTOR ASS'Y	8P 120mm C&C	
2-12	EL300650	PW HEAD B-TITE SCREW	3x8-8 MFC2BL	
2-15	CB836200	BINDING TIE	S-70B	
* 5	V9646000	P. C. B. ASS'Y	GD:MAIN	GD
* 5	V9646100	P. C. B. ASS'Y	GD:MAIN	GD
* 11	V2296800	POWER CABLE	2m	UC
* 11	V9293500	POWER CABLE	2m	UC
21	V2438700	CORD STOPPER	10P1	
101	V7127400	TOP COVER		GD
101	V7127300	TOP COVER		SI
* 103	V9046700	REAR PANEL		UC
* 103	V9046800	REAR PANEL		A
* 104	V9047100	LID/CDC		GD
* 104	V9047200	LID/CDC		SI
110	VR264400	SPACER	H8	
111	V3688500	LEG	M0080-M0	
112	VQ390100	DAMPER	8x8x15	
113	VP857700	DAMPER	4x6x5	
140	VN413300	BIND HEAD BONDING B-T. SCREW	3x8 MFZN2BL	
141	EP600830	BIND HEAD B-TITE SCREW	3x8 MFC2BL	
142	EP600250	BIND HEAD B-TITE SCREW	3x8 MFZN2Y	
143	EL300650	PW HEAD B-TITE SCREW	3x8-8 MFC2BL	
144	V2728500	BIND HEAD S-TITE SCREW	4x7 MFZN2BL	
145	VT669400	PW HEAD B-TITE SCREW	3x15-8 MFC2	
146	EP600790	FLAT HEAD B-TITE SCREW	3x8 MFZN2BL	
147	VY712800	PW HEAD B-TITE SCREW	3x8-8 MFNI33	
ACCESSORIES OF CRX-E500				
* 200	V8913600	REMOTE CONTROL	RC-7060-01-0029	RC-7060-01-0029
200-1	AAX13340	BATTERY COVER	BLJYE 60050001	60050001
202	V6267000	INDOOR FM ANTENNA	1.4m 1pc	UC
202	VQ147100	INDOOR FM ANTENNA	1.4m 1pc	A
203	VR248500	AM LOOP ANTENNA	1.0m 1pc	
204	VY952200	AUDIO PIN CABLE	2P 1m 1pc	
205	V4135300	SYSTEM CONTROL CABLE	1P 1m 1pc	
		BATTERY, MANGANESE	UM-3, AA, R06	

\* New Parts

# 1 ■ EXPLODED VIEW (CDC Mechanism Unit)

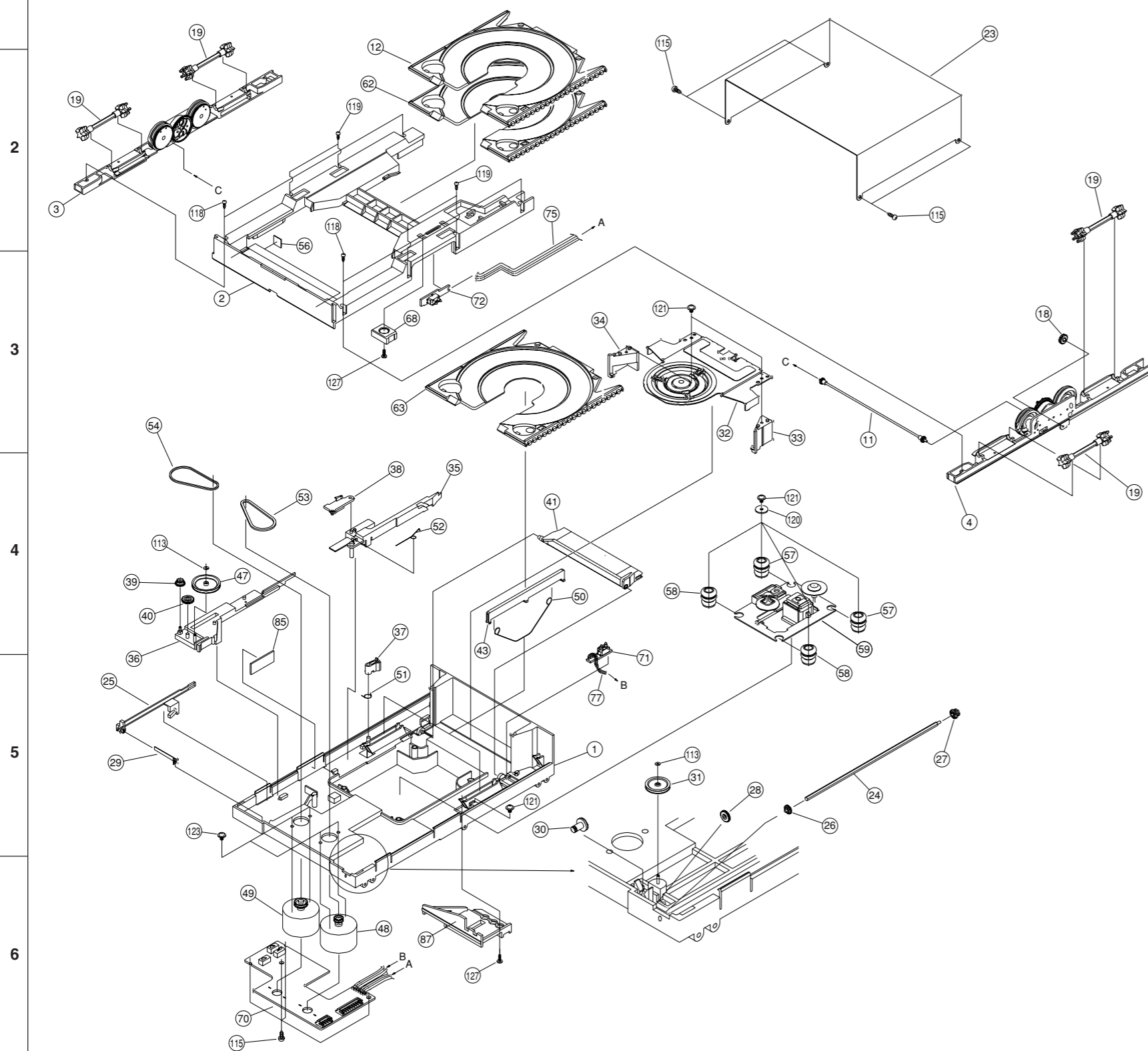

# ■ MECHANICAL PARTS (CDC Mechanism Unit)

Ref. No.	PART NO.	Description	Remarks	Markets
	V7527900	CDC MECHANISM UNIT	CMCJ0125	
1	AAx25400	ASS'Y CHASSIS	45 093 4256	
2	AAx25490	DRAWER 2	45 264 3278	
3	AAx25640	ASS'Y HOLDER L	45 093 3141	
4	AAx25650	ASS'Y HOLDER R3B	45 093 3296	
11	AAx25360	ASS'Y GEAR DRIVE	45 093 4232	
12	AAx25160	ASS'Y CRG 101	45 093 4347	
18	AAx25600	BEVEL GEAR 4	45 222 4214	
19	AAx25340	ASS'Y GEAR STAR	45 093 4244	
23	AAx25300	COVER 2	45 112 3154	
24	AAx25410	SHAFT	45 300 4173	
25	AAx25480	SLIDER 4	45 259 3175	
26	AAx25350	GEAR SPLINE	45 222 4021	
27	AAx25580	BEVEL GEAR 1	45 222 4059	
28	AAx25310	GEAR IDLER 1	45 222 4176	
29	AAx25570	PLATE SPRING	45 160 4174	
30	AAx25590	BEVEL GEAR 3	45 222 4177	
31	AAx25560	PULLEY C	45 222 4058	
32	AAx25380	ASS'Y CLAMPER SA	45 093 4346	
33	AAx25270	ARM SLIDER R	45 219 3187	
34	AAx25260	ARM SLIDER L	45 219 3188	
35	AAx25460	SLIDER 1	45 259 2185	
36	AAx25470	ASS'Y SLIDER 2	45 093 3240	
37	AAx25240	ARM STOPPER A2	45 239 4279	
38	AAx25250	ARM STOPPER B	45 239 4065	
39	AAx25320	GEAR IDLER A2	45 222 4128	
40	AAx25330	GEAR IDLER C	45 222 4051	
41	AAx25690	LEVER 2	45 259 3289	
43	AAx25680	LIFTER	45 259 3025	
47	AAx25550	PULLEY A	45 229 4052	
48	AAx25190	ASS'Y MOTOR CRG S	45 093 4238	
49	AAx25200	ASS'Y MOTOR DRW S	45 093 4239	
50	AAx25420	SPRING	01 080 4541	
51	AAx25430	SPRING	01 082 4643	
52	AAx25440	SPRING	01 082 4647	
53	AAx25610	BELT	02 083 4214	
54	AAx25620	BELT	02 083 4215	
56	AAx25370	CUSHION	45 063 4136	
57	AAx25280	INSULATOR	45 063 3201	
58	AAx25290	INSULATOR	45 063 3202	
59	V3175200	PU MECHA. UNIT	DA11T3	
62	AAx25170	ASS'Y CRG 201	45 093 4348	
63	AAx25180	ASS'Y CRG 301	45 093 4349	
68	AAx25450	SPACER SW	45 219 4127	
70	AAx25210	ASS'Y PC BOARD A	45 093 4263	
71	AAx25220	ASS'Y PC BOARD B	45 093 4265	
72	AAx25230	ASS'Y PC BOARD C	45 093 4264	
75	AAx25660	LEAD WIRE	45 072 4171	
77	AAx25670	LEAD WIRE	45 072 4172	
85	AAx25390	RUBBER CUSHION	45 063 4115	
87	AAx25630	HOLDER WIRE	45 212 3152	
113	AAx25710	WASHER	GWP15X045025S	
115	AAx25510	SCREW	GSL20A2606	
118	AAx25520	SCREW	GSL20B2006	
119	AAx25500	SCREW	GSL10B2006	
120	AAx25700	WASHER	GWN31X120050	
121	AX622290	SCREW	GSL15A2608	
123	AAx25530	SCREW	GSP15A2604	
127	AAx25540	SCREW	GST15A2005	

\* New Parts

GREASE APPLICATION DIAGRAM (CDC Mechanism Unit)

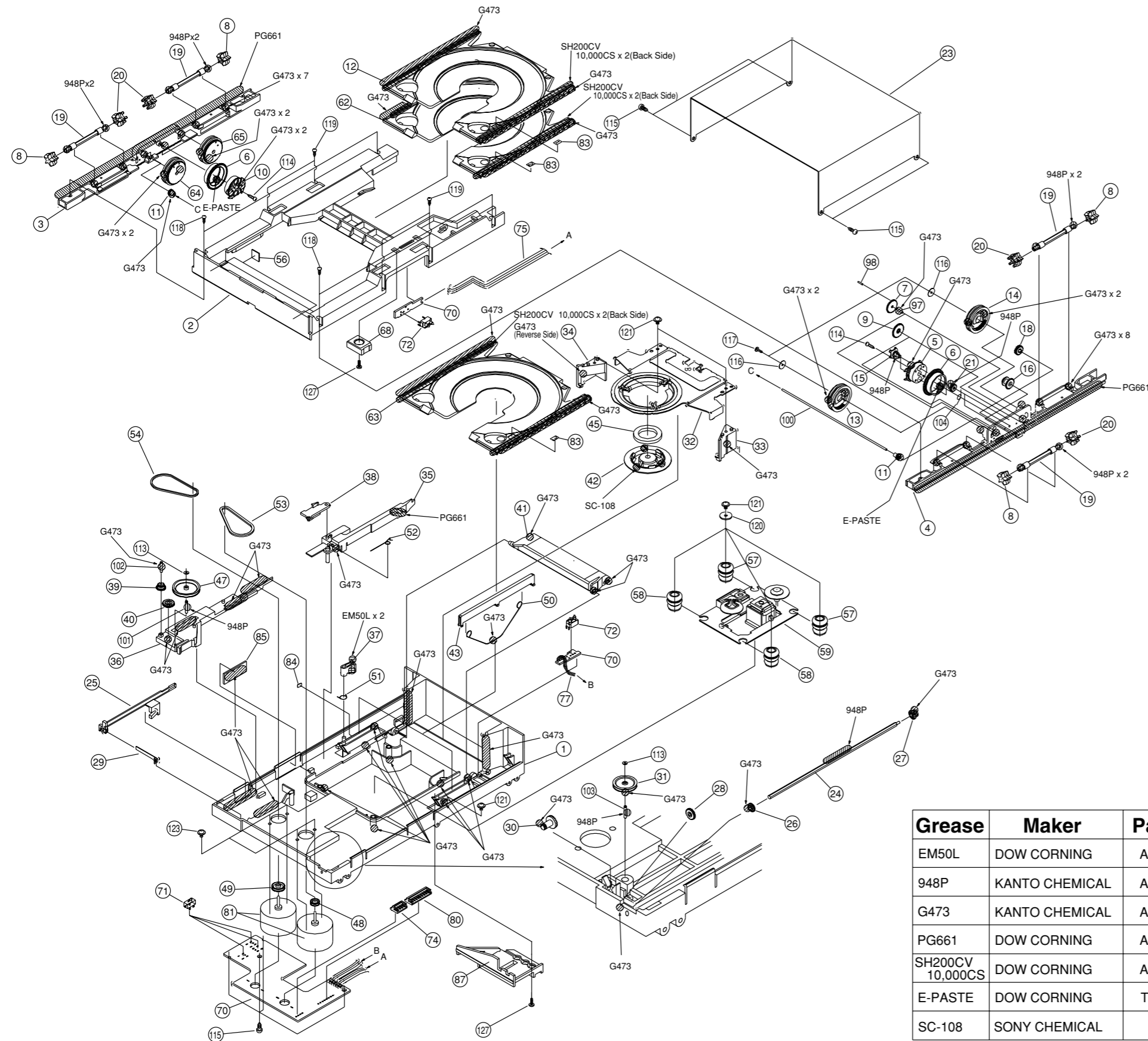

Grease	Maker	Part No.
EM50L	DOW CORNING	AAX27910
948P	KANTO CHEMICAL	AAX27940
G473	KANTO CHEMICAL	AAX27950
PG661	DOW CORNING	AAX27920
SH200CV 10,000CS	DOW CORNING	AAX27930
E-PASTE	DOW CORNING	TX913420
SC-108	SONY CHEMICAL	

1

## EXPLODED VIEW (PU Mecha. Unit)

### Note :

Neither the pick-up head nor the spindle motor is available independently because they are factory-adjusted for the optimum level after assembly. If the pick-up head or the spindle motor must be replaced, be sure to replace them together as a unit.

2

3

4

5

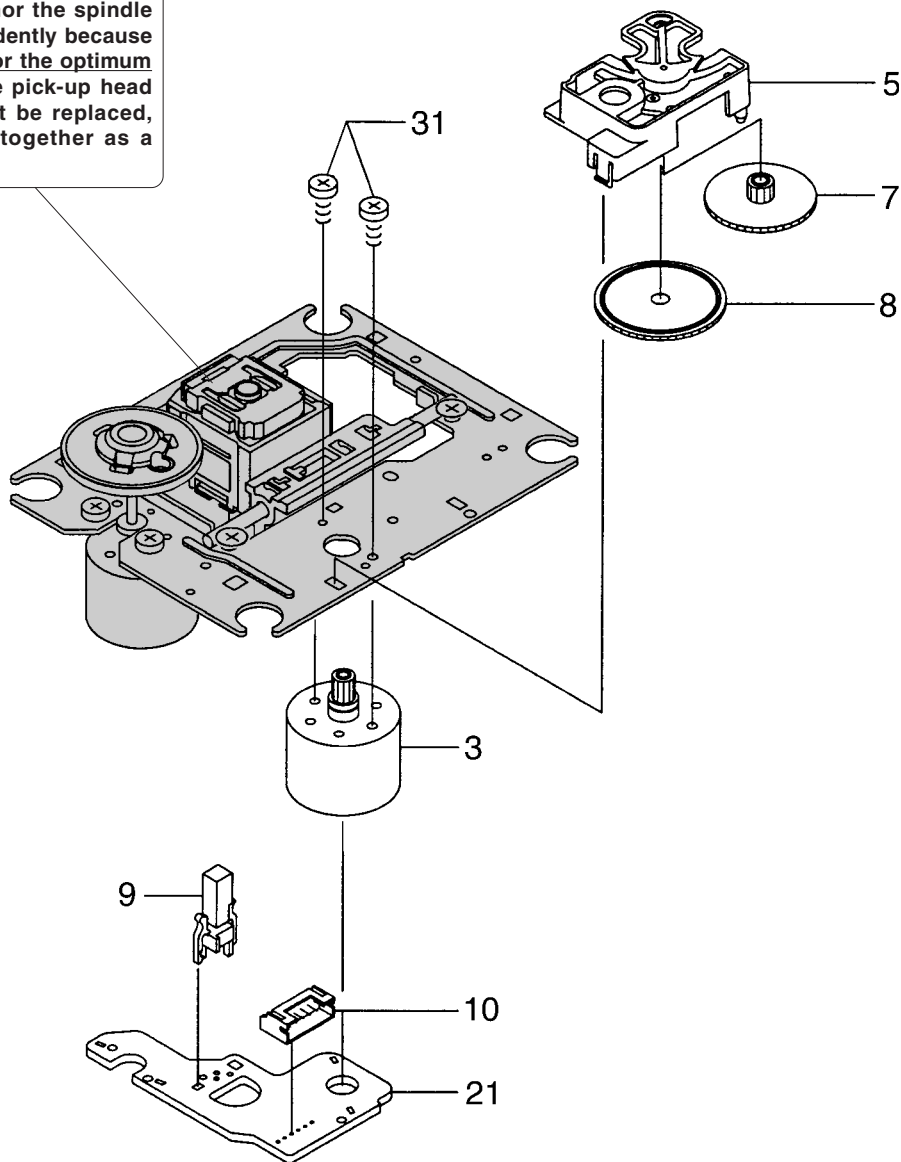

6

Ref. No.	PART NO.	Description	Remarks	Markets
	V3175200	PU MECHA. UNIT	DA11T3	
3	XX702580	SLED MOTOR ASS'Y	6.0V	1EA0M10A09700
5	XX702590	COVER, GEAR		1EA2121A20000
7	XX702610	GEAR, MIDDLE		1EA2511A21000
8	XX702600	GEAR, DRIVE		1EA2511A21100
9	XX702660	SWITCH, LEAF	PWB MOTOR	1EA4S13A01600
10	XX702620	CONNECTOR, S	6P	1EA4J13A54700
21	XX702570	PWB, MOTOR		1EA4B10B06100
31	XX702640	SCREW, PAN PCS	2x3	SE1PN203ROSE

7

\* New Parts

# GREASE APPLICATION DIAGRAM (PU Mechanism)

<b>Apply the grease</b>
Molykote PG-663 (P/No. AAX01170)

