

DVD PLAYER

DVD-S661

SERVICE MANUAL

For G model

This service manual is for the DVD-S661 (G model).

For the DVD-S661/DV-S6160 (U, K, A, L, P models) service manual, please refer to the following publication number:

DVD-S661/DV-S6160 (U, K, A, L, P models): 101050

IMPORTANT NOTICE

This manual has been provided for the use of authorized YAMAHA Retailers and their service personnel. It has been assumed that basic service procedures inherent to the industry, and more specifically YAMAHA Products, are already known and understood by the users, and have therefore not been restated.

WARNING: Failure to follow appropriate service and safety procedures when servicing this product may result in personal injury, destruction of expensive components, and failure of the product to perform as specified. For these reasons, we advise all YAMAHA product owners that any service required should be performed by an authorized YAMAHA Retailer or the appointed service representative.

IMPORTANT: The presentation or sale of this manual to any individual or firm does not constitute authorization, certification or recognition of any applicable technical capabilities, or establish a principle-agent relationship of any form.

The data provided is believed to be accurate and applicable to the unit(s) indicated on the cover. The research, engineering, and service departments of YAMAHA are continually striving to improve YAMAHA products. Modifications are, therefore, inevitable and specifications are subject to change without notice or obligation to retrofit. Should any discrepancy appear to exist, please contact the distributor's Service Division.

WARNING: Static discharges can destroy expensive components. Discharge any static electricity your body may have accumulated by grounding yourself to the ground buss in the unit (heavy gauge black wires connect to this buss).

IMPORTANT: Turn the unit OFF during disassembly and part replacement. Recheck all work before you apply power to the unit.

■ CONTENTS

TO SERVICE PERSONNEL	2-3	DISASSEMBLY PROCEDURES	8
PREVENTION OF ELECTROSTATIC DISCHARGE	4	TEST MODE	9
LOCALE MANAGEMENT INFORMATION	4	BLOCK DIAGRAM	10
FRONT PANEL	5	WIRING DIAGRAM	11
REAR PANEL	5	PRINTED CIRCUIT BOARDS	12-17
REMOTE CONTROL PANEL	5	SCHEMATIC DIAGRAMS	18-24
SPECIFICATIONS	6-7	REPLACEMENT PARTS LIST	26-27
INTERNAL VIEW	7	REMOTE CONTROL	27
REPAIR NOTES	7	SCENE CONTROL	28
TRADE MODE	7		



このサービスマニュアルは、エコマーク認定の再生紙を使用しています。
This Service Manual uses recycled paper.

101047

© 2007 YAMAHA CORPORATION All rights reserved.
This manual is copyrighted by YAMAHA and may not be copied or
redistributed either in print or electronically without permission.



YAMAHA

YAMAHA CORPORATION
P.O.Box 1, Hamamatsu, Japan

'07.03

■ TO SERVICE PERSONNEL

1. Critical Components Information
Components having special characteristics are marked \triangle and must be replaced with parts having specifications equal to those originally installed.
 2. Leakage Current Measurement (For 120V Models Only)
When service has been completed, it is imperative to verify that all exposed conductive surfaces are properly insulated from supply circuits.
- Meter impedance should be equivalent to 1500 ohms shunted by 0.15 μ F.

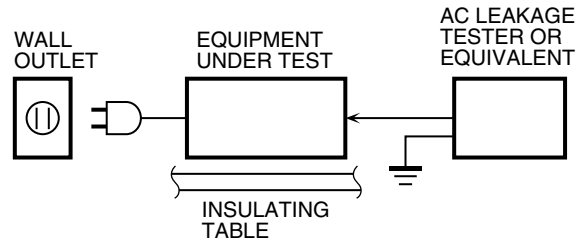

- Leakage current must not exceed 0.5mA.
- Be sure to test for leakage with the AC plug in both polarities.

WARNING: CHEMICAL CONTENT NOTICE!

The solder used in the production of this product contains LEAD. In addition, other electrical/electronic and/or plastic (where applicable) components may also contain traces of chemicals found by the California Health and Welfare Agency (and possibly other entities) to cause cancer and/or birth defects or other reproductive harm.

DO NOT PLACE SOLDER, ELECTRICAL/ELECTRONIC OR PLASTIC COMPONENTS IN YOUR MOUTH FOR ANY REASON WHATSOEVER!

Avoid prolonged, unprotected contact between solder and your skin! When soldering, do not inhale solder fumes or expose eyes to solder/flux vapor!

If you come in contact with solder or components located inside the enclosure of this product, wash your hands before handling food.

WARNING: Laser Safety

This product contains a laser beam component. This component may emit invisible, as well as visible radiation, which may cause eye damage. To protect your eyes and skin from laser radiation, the following precautions must be used during servicing of the unit.

- 1) When testing and/or repairing any component within the product, keep your eyes and skin more than 30 cm away from the laser pick-up unit at all times. Do not stare at the laser beam at any time.
- 2) Do not attempt to readjust, disassemble or repair the laser pick-up, unless noted elsewhere in this manual.
- 3) CAUTION : Use of controls, adjustments or performance of procedures other than those specified herein may result in hazardous radiation exposure.

Laser Emitting conditions:

- 1) When the Top Cover is removed, and the STANDBY/ON SW is turned to the "ON" position, the laser component will emit a beam for several seconds to detect if a disc is present. During this time (5-10 sec.) the laser may radiate through the lens of the laser pick-up unit. Do not attempt any servicing during this period!
If no disc is detected, the laser will stop emitting the beam. When a disc is loaded, you will not be exposed to any laser emissions.
- 2) The laser power level can be adjusted with the VR on the pick-up PWB, however, this level has been set by the factory prior to shipping from the factory. Do not adjust this laser level control unless instruction is provided elsewhere in this manual. Adjustment of this control can increase the laser emission level from the device.

Laser Diode Properties

Type:	Semiconductor laser GaAlAs
Wave length:	650 nm (DVD) 780 nm (VCD/CD)
Output Power:	7 mW (DVD) 10 mW (VCD/CD)
Beam divergence:	60 degree

WARNING

The use of optical instruments with this product will increase eye hazard.

Repair handling should take place as much as possible with a disc loaded inside the player.

CAUTION

VISIBLE AND INVISIBLE LASER RADIATION WHEN OPEN. AVOID EXPOSURE TO BEAM.

ADVARSEL

SYNLIG OG USYNLIG LASERSTRÅLING VED ÅBNING. UNDGÅ UDSÆTTELSE FOR STRÅLING.

ADVARSEL

SYNLIG OG USYNLIG LASERSTRÅLING NÅR DEKSEL ÅPNES. UNNGÅ EKSPONERING FOR STRÅLEN.

VARNING

SYNLIG OCH OSYNLIG LASERSTRÅLNING NÅR DENNA DEL ÄR ÖPPNAD. BETRakta EJ STRÅLEN.

VARO!

AVATTAESSA OLET ALTTIINA NÄKYVÄLLE JA NÄKYMÄTTÖMÄLLE LASER SÄ TEILYLLE. ÄLÄ KATSO SÄTEESEEN.

VORSICHT

SICHTBARE UND UNSICHTBARE LASERSTRAHLUNG WENN ABDECKUNG GEÖFFNET. NICHT DEM STRAHL AUSSETZEN.

DANGER

VISIBLE AND INVISIBLE LASER RADIATION WHEN OPEN. AVOID DIRECT EXPOSURE TO BEAM.

ATTENTION

RAYONNEMENT LASER VISIBLE ET INVISIBLE EN CAS D'OUVERTURE. EXPOSITION DANGEREUSE AU FAISCEAU.

ПРЕДУПРЕЖДЕНИЕ

ПРИ ОТКРЫТИИ УСТРОЙСТВА ВЫ МОЖЕТЕ ПОДВЕРГНУТЬСЯ ВОЗДЕЙСТВИЮ ВИДИМОГО И НЕВИДИМОГО ЛАЗЕРНОГО ИЗЛУЧЕНИЯ. ИЗБЕГАЙТЕ ВОЗДЕЙСТВИЯ ЛУЧА.

OSTRZEŻENIE

WIDZIALNE I NIEWIDZIALNE PROMIENIOWANIE LASEROWE PO OTWARCIU. UNIKAĆ NARAŻENIA NA WIĄZKĘ LASEROWĄ.

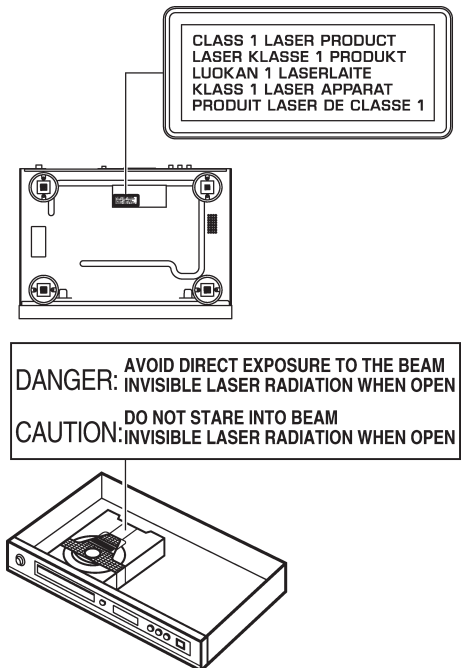

Warning for power supply

The primary side of the power supply carries live mains voltage when the player is connected to the mains even when the player is switched off !

This primary area is not shielded so it is possible to touch copper tracks and/or components when servicing the player. Service personnel have to take precautions to prevent touching this area or components in this area.

Note:

The screws on the DVD mechanism may never be touched, removed or re-adjusted.

Handle the DVD mechanism with care when the unit has to be exchanged!

The DVD mechanism is very sensitive for dropping or giving shocks.

■ PREVENTION OF ELECTROSTATIC DISCHARGE

The laser diode in the DVD mechanism may be damaged due to static electricity from clothes or the human body. Use caution to prevent electrostatic damage when servicing or handling the DVD-mechanism.

1. Grounding for electrostatic damage prevention

Some devices, such as the DVD player, use an optical pickup (laser diode) that will be damaged by static electricity in the working environment. Only attempt service after ensuring that all grounding procedures have been completed.

1. Worktable grounding

Put a grounded conductive material (sheet) or iron sheet on the area where the optical pickup is placed.

2. Human body grounding

Use an anti-static wrist strap to discharge the static electricity from your body.

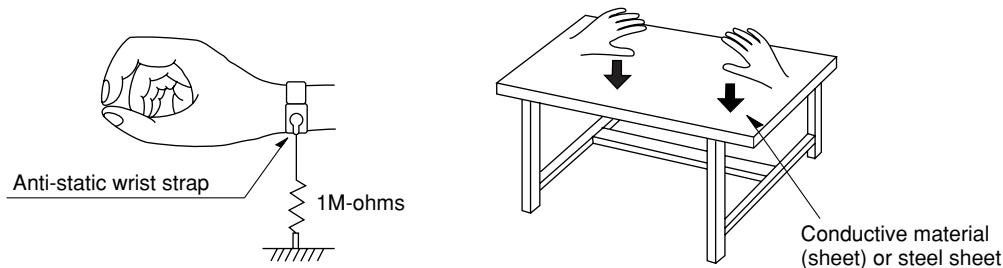

2. Handling Precautions for DVD mechanism

1. Handle the DVD mechanism gently, as it is an extremely high-precision assembly.
2. The flexible cable lines may break if an excessive force is applied to it. Use caution when handling the cable.
3. The semi-fixed resistor for laser power adjustment should not be adjusted. Do not turn the resistor.

■ LOCALE MANAGEMENT INFORMATION

Locale Management Information : This DVD player is designed and manufactured to respond to the Locale Management Information that is recorded on a DVD disc. If the Locale number described on the DVD disc does not correspond to the Locale number of this DVD player, this DVD player cannot play this disc.

This product incorporates copyright protection technology that is protected by method claims of certain U.S. patents and other intellectual property rights owned by Macrovision Corporation and other rights owners. Use of this copyright protection technology must be authorized by Macrovision Corporation, and is intended for home and other limited viewing uses only unless otherwise authorized by Macrovision Corporation. Reverse engineering or disassembly is prohibited.

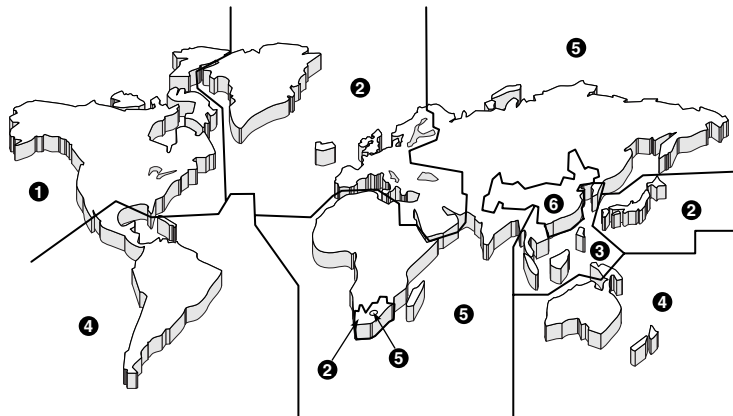

FRONT PANEL

G model

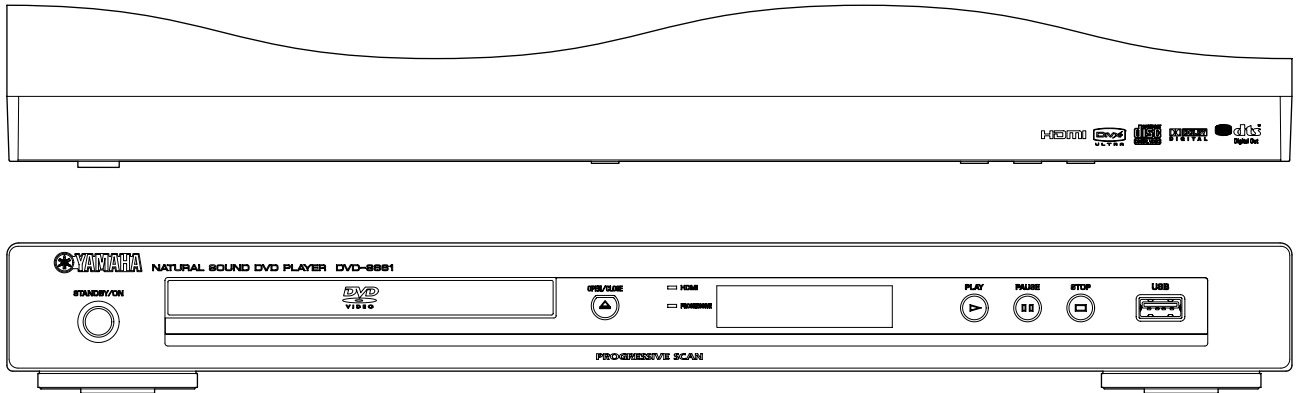

REAR PANEL

G model

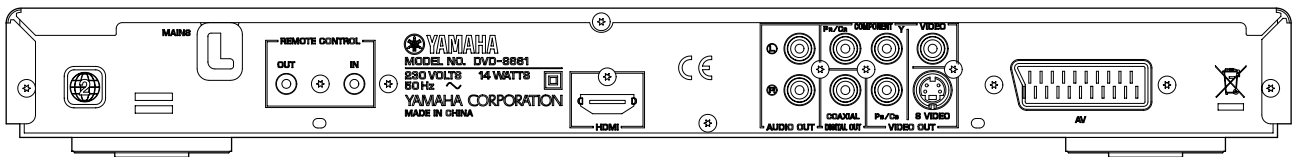

REMOTE CONTROL PANEL

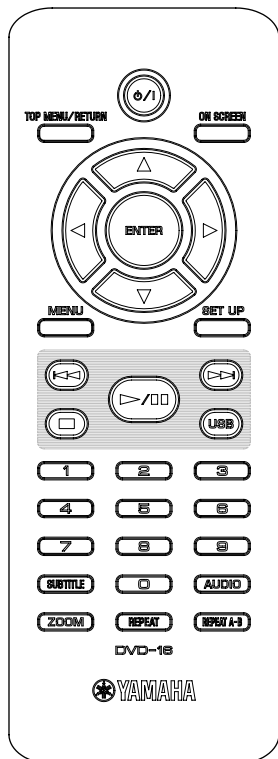

■ SPECIFICATIONS

PLAYBACK SYSTEM

DVD Video, VR (Video Recording) format (DVD-RW)	
DVD-R, DVD-RW, DVD-R DL	
DVD+R, DVD+RW, DVD+R DL	
Video CD, SVCD	
CD	
PICTURE CD	
CD-R, CD-RW	
MP3 (ISO 9660)	fs 32, 44.1, 48 kHz / 96, 128, 256, 320 kbps (Constant bit rate)
WMA	fs 44.1 kHz, 62 to 192 kbps / fs 48 kHz, 128 to 192 kbps (Constant bit rate)
DivX	
JPEG	3072 x 2048 dpi or less

VIDEO PERFORMANCE

Video (CVBS) output	1 Vpp into 75 ohms
S-Video output	Y: 1 Vpp into 75 ohms C: 0.3 Vpp into 75 ohms
Component video output	Y: 1 Vpp into 75 ohms PB/CB PR/CR: 0.7 Vpp into 75 ohms
RGB (SCART) output	Y: 0.7 Vpp into 75 ohms
HDMI upscaling	576 p, 720 p, 1080 i

AUDIO FORMAT

Digital	
Dolby Digital, DTS, MPEG	Compressed digital
PCM	fs 44.1, 48, 96 kHz / 16, 20, 24 bits
Analog sound	Stereo

AUDIO PERFORMANCE

DA converter	24 bits
Signal to noise (1 kHz)	105 dB
Dynamic range (1 kHz)	97 dB
DVD	fs 96 kHz 2 Hz to 44 kHz fs 48 kHz 2 Hz to 22 kHz
SVCD	fs 48 kHz 2 Hz to 22 kHz fs 44.1 kHz 2 Hz to 20 kHz
CD/VCD	fs 44.1 kHz 2 Hz to 20 kHz
Distortion and noise (1 kHz)	0.0035 %

MULTIMEDIA (USB) APPLICATIONS

Connections	USB mass storage class device
Playback formats (USB device)	
MP3	fs 32, 44.1, 48 kHz / 96, 128, 256, 320 kbps
WMA	fs 44.1 kHz / 62 to 192 kbps fs 48 kHz / 128 to 192 kbps
DivX	3 Mbps or less
JPEG	3072 x 2048 dpi or less

Supported USB devices (FAT16 or FAT32 format)	FLASH memory Card reader (up to 6 slots) Portable audio player External hard disk drive (80 GB or less)
---	--

TV STANDARD

	(PAL/50 Hz)	(NTSC/60 Hz)
Number of lines	625	525
Playback	Multistandard (PAL/NTSC)	

CONNECTIONS

Video output	RCA/Phono x 1 (yellow)
S-video output	Mini DIN, 4 pins x 1
Component video output	
Y output	RCA/Phono x 1 (green)
PB/CB output	RCA/Phono x 1 (blue)
PR/CR output	RCA/Phono x 1 (red)
SCART	Euroconnector x 1
Audio output (L+R)	RCA/Phono x 1 pair (white/red)
Digital output	
Coaxial	RCA/Phono x 1 IEC60958 for CDDA/LPCM / IEC61937 for MPEG 1/2, Dolby Digital and DTS
HDMI (HDMI 1.0)	Type A x 1
USB	Type A x 1
Remote control	
Input	3.5 mm mini jack x 1
Output	3.5 mm mini jack x 1

GENERAL

Dimensions (W x H x D)	435 x 51 x 318 mm (17-1/8" x 2" x 12-1/2")
Weight	Approx. 2.6 Kg (5 lbs. 12 oz)
Finish	Black color Titanium color Silver color
Power supply	AC 230 V, 50 Hz
Power consumption	Approx. 14 W
Standby power consumption	Less than 1 W

ACCESSORIES

Remote control x 1
Battery (AAA, R03, UM-4) x 2
Audio pin cable (1.5 m) x 1
Video pin cable (1.5 m) x 1

* **Specifications are subject to change without prior notice.**

G European model

DOLBY DIGITAL Manufactured under license from Dolby Laboratories. "Dolby", "Pro Logic" and the double-D symbol are trademarks of Dolby Laboratories.

dts Digital Out "DTS" and "DTS Digital Out" are registered trademarks of DTS, Inc.

DIVX ULTRA HOME THEATER DIVX CERTIFIED VIDEO DivX, DivX Ultra Certified, and associated logos are trademarks of DivX, Inc. and are used under license.

HDMI HIGH DEFINITION MULTIMEDIA INTERFACE HDMI, the HDMI logo and High Definition Multimedia Interface are trademarks or registered trademarks of HDMI Licensing LLC.

This product incorporates copyright protection technology that is protected by method claims of certain U.S. patents and other intellectual property rights owned by Macrovision Corporation and other rights owners. Use of this copyright protection technology must be authorized by Macrovision Corporation, and is intended for home and other limited viewing uses only unless otherwise authorized by Macrovision Corporation. Reverse engineering or disassembly is prohibited.

• **DIMENSIONS**

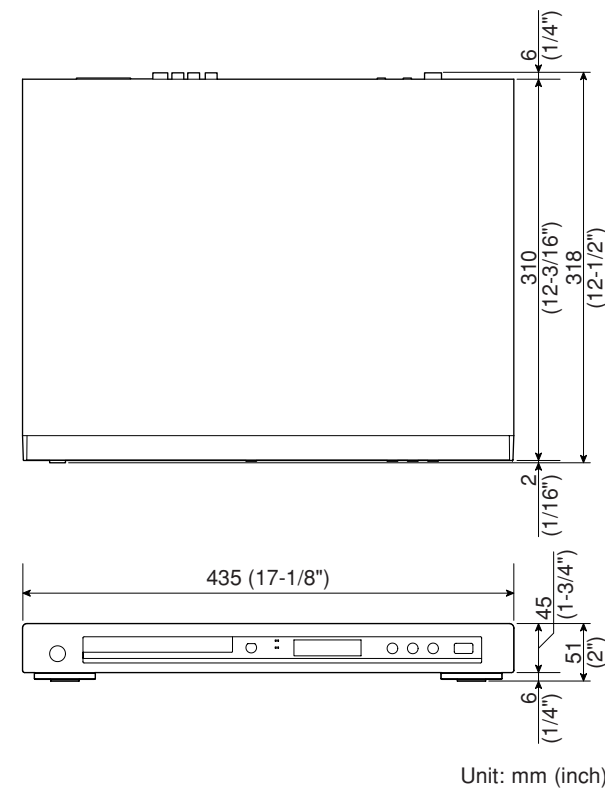

■ **REPAIR NOTES**

None of the components of the following unit can be supplied separately. Each unit must be replaced as a whole in case of a failure.

- DVD Mechanism
- MONO P.C.B.
- FRONT P.C.B.
- AV P.C.B.
- Power Supply Unit

■ **TRADE MODE**

This unit provides TRADE mode which prevents the tray from opening even when the "OPEN/CLOSE" key is pressed.

• **Activating TRADE mode**

The power to the main unit should be turned on before activating the TRADE mode.

1. Press the "OPEN/CLOSE" key to open the tray. (Fig. 1)
2. Press the "2", "5" and "9" keys on the remote control in that order. (Fig. 2)
3. "TRA ON" is displayed and TRADE mode is activated. About 2 seconds later, the tray is closed automatically. (Fig. 3)

Notes)

- After activating TRADE mode, it is not possible to operate keys of the main unit as usual except the following key.
"STANDBY/ON" key (Turn on the power only)
But operation with the remote control is available as usual.
- After TRADE mode is activated, initial settings for repeat reproduction of this unit are as follows.
DVD : RPT TT (repeat title)
VCD/SVCD/CD : RPT ALL (repeat all)

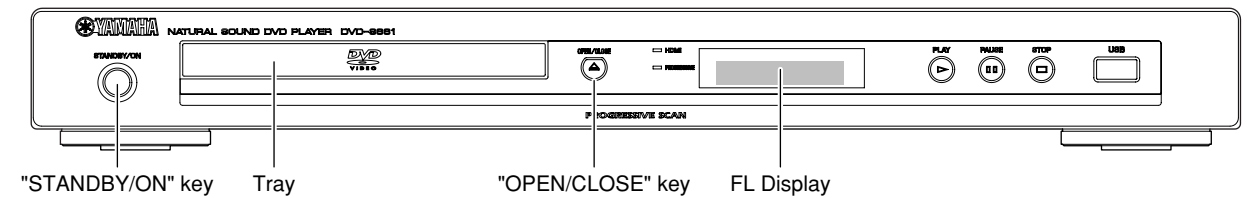
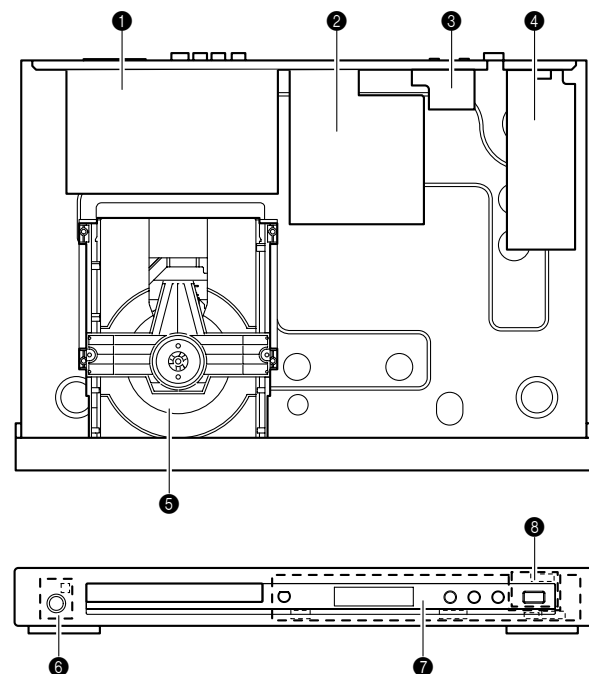

Fig. 1

■ **INTERNAL VIEW**



- ① AV P.C.B.
- ② MONO P.C.B.
- ③ FRONT (4) P.C.B.
- ④ Power Supply Unit
- ⑤ DVD Mechanism

- ⑥ FRONT (2) P.C.B.
- ⑦ FRONT (1) P.C.B.
- ⑧ FRONT (3) P.C.B.

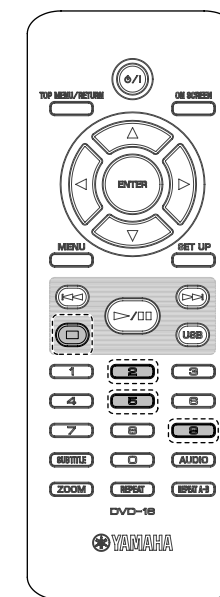

Fig. 2

TRADE mode display

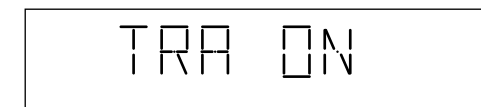

Fig. 3

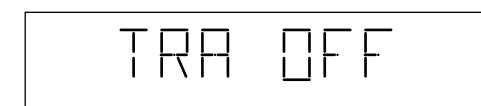

Fig. 4

• **Canceling TRADE mode**

The power to the main unit should be turned on before canceling TRADE mode.

1. Press and hold the "STOP" key on the remote control. (Fig. 2)
The tray opens after about 2 second.
2. Press the "2", "5" and "9" keys on the remote control in that order. (Fig. 2)
3. "TRA OFF" is displayed and TRADE mode is cancelled. About 2 seconds later, the tray is closed automatically. (Fig. 4)

DISASSEMBLY PROCEDURES

See REPLACEMENT PARTS LIST for item numbers.

When disassembling, use the special screw driver with tip shape in figure.

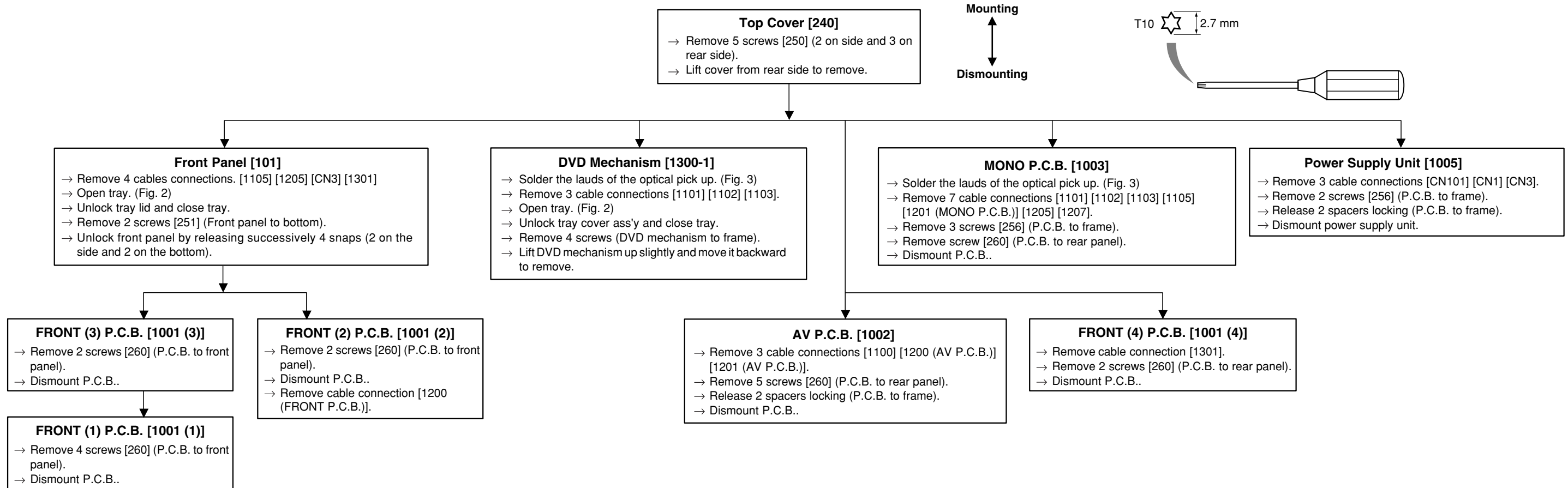

● Cable connections

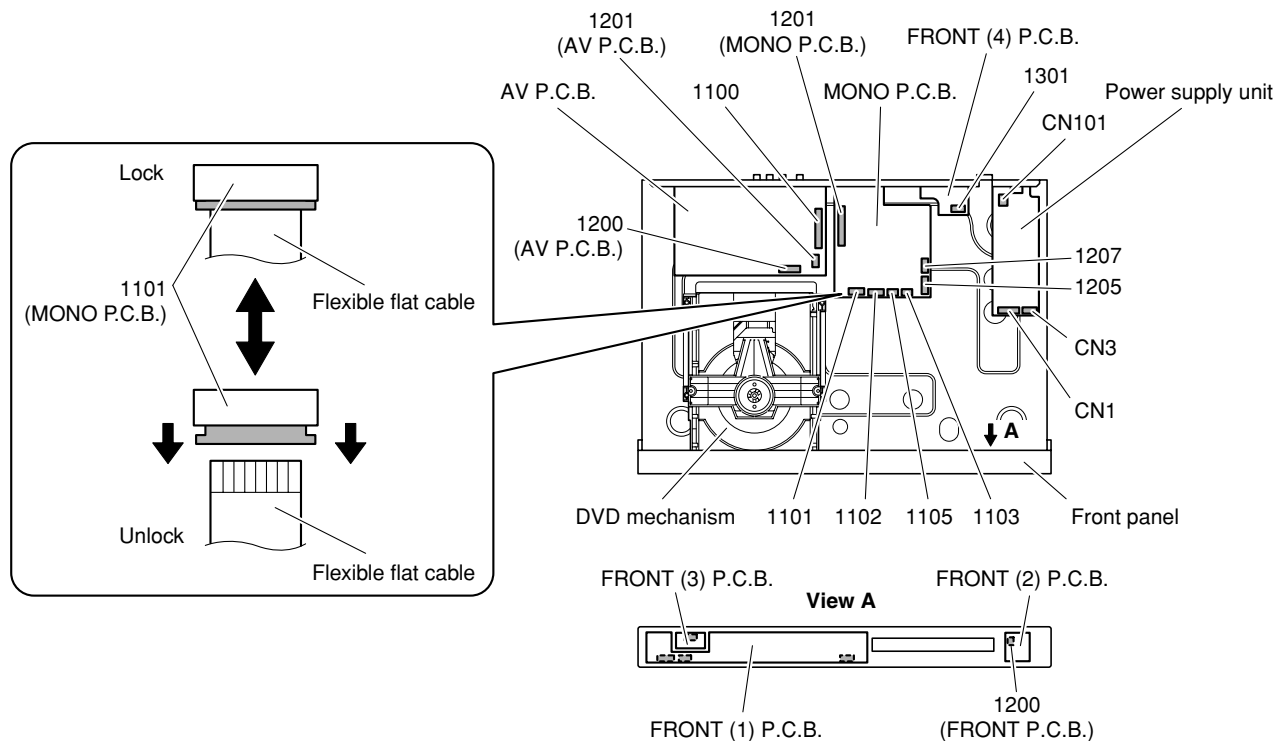

Fig. 1

● How to manually eject the tray

- Move the slider in the direction indicated with a screw driver until the tray is ejected.
- Gently pull the tray out.

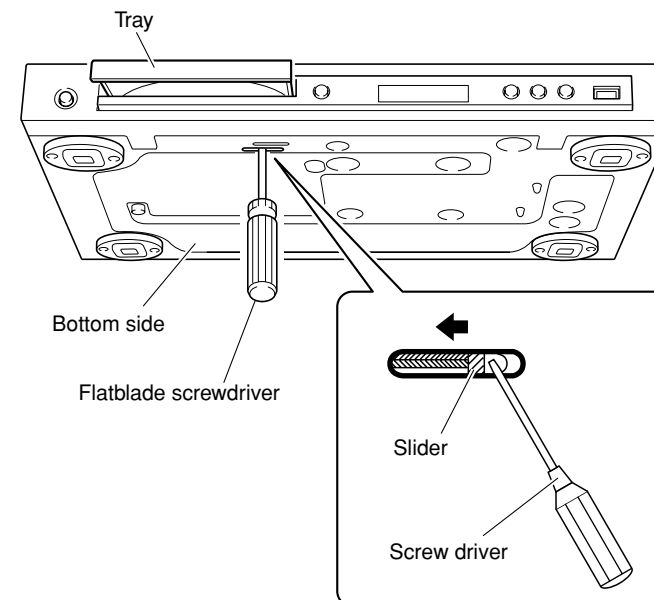

Fig. 2

● Preventive measure for laser diode from electrostatic breakdown

When replacing the MONO P.C.B. or DVD mechanism, solder between lands of the optical pick up P.C.B. to protect the laser diode against electrostatic breakdown.

Notes

- Use an anti-static soldering iron to short-circuit and unshort-circuit laser diode.
- After you have finished repairing, remove the solder from the short-circuit location.

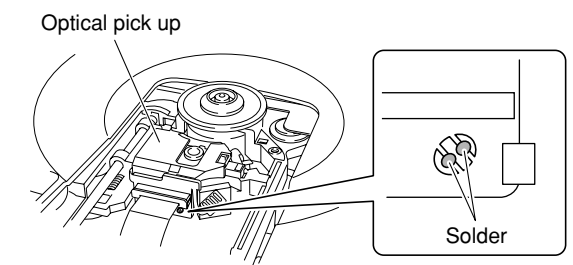

Fig. 3

■ TEST MODE

• Starting Test Mode

- Connect the power cable to the AC power outlet.
- Press the "STANDBY/ON" key while simultaneously pressing "PAUSE" and "STOP" keys of the main unit.
At this time, keep pressing "PAUSE" and "STOP" keys for 8 seconds or longer.
- The "FV xx" (firmware version) is displayed.

• Display Test

The display condition varies as shown below according to the "PLAY" key of the main unit.

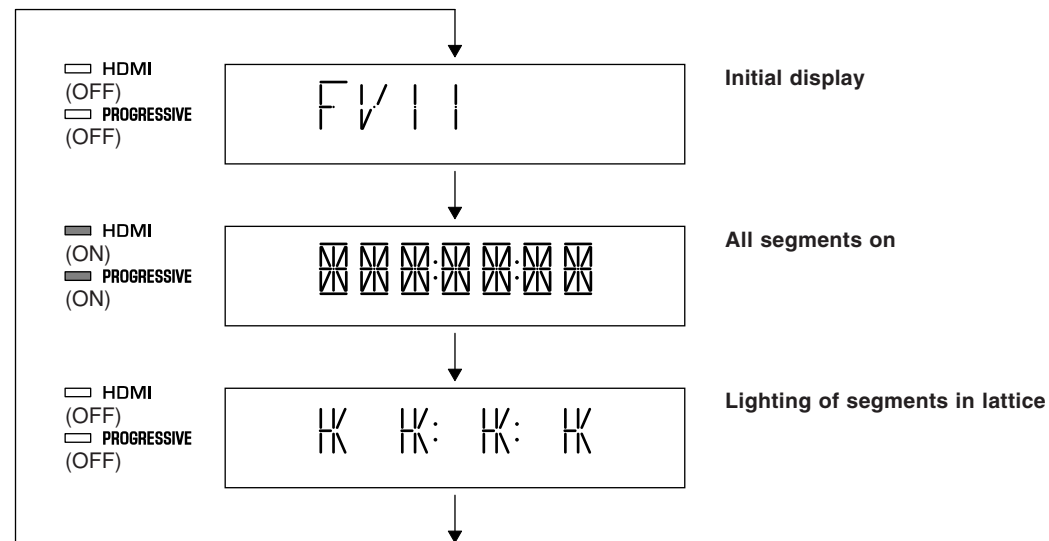

• Panel Key Test

The display changes as shown below as the specified key is pressed.

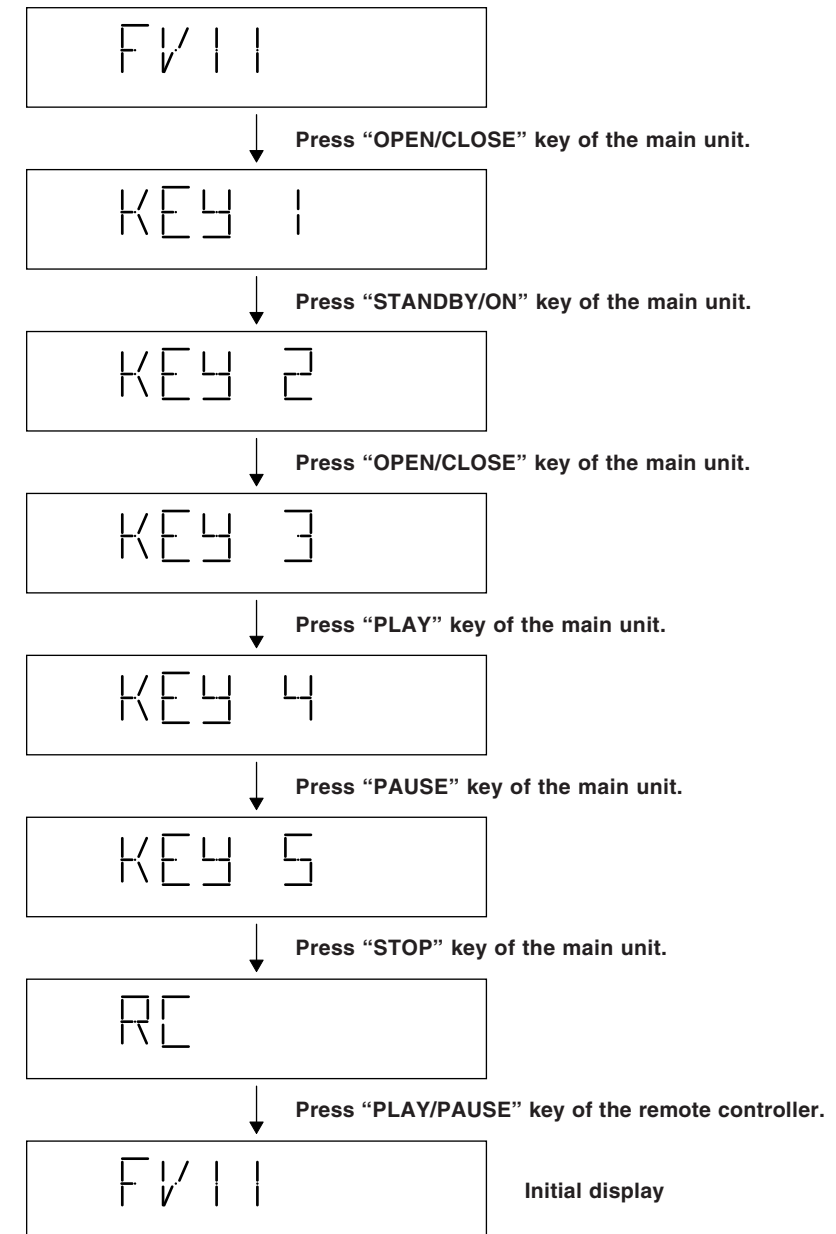

• Canceling Test Mode

Disconnect the power cable from the AC power outlet.

BLOCK DIAGRAM

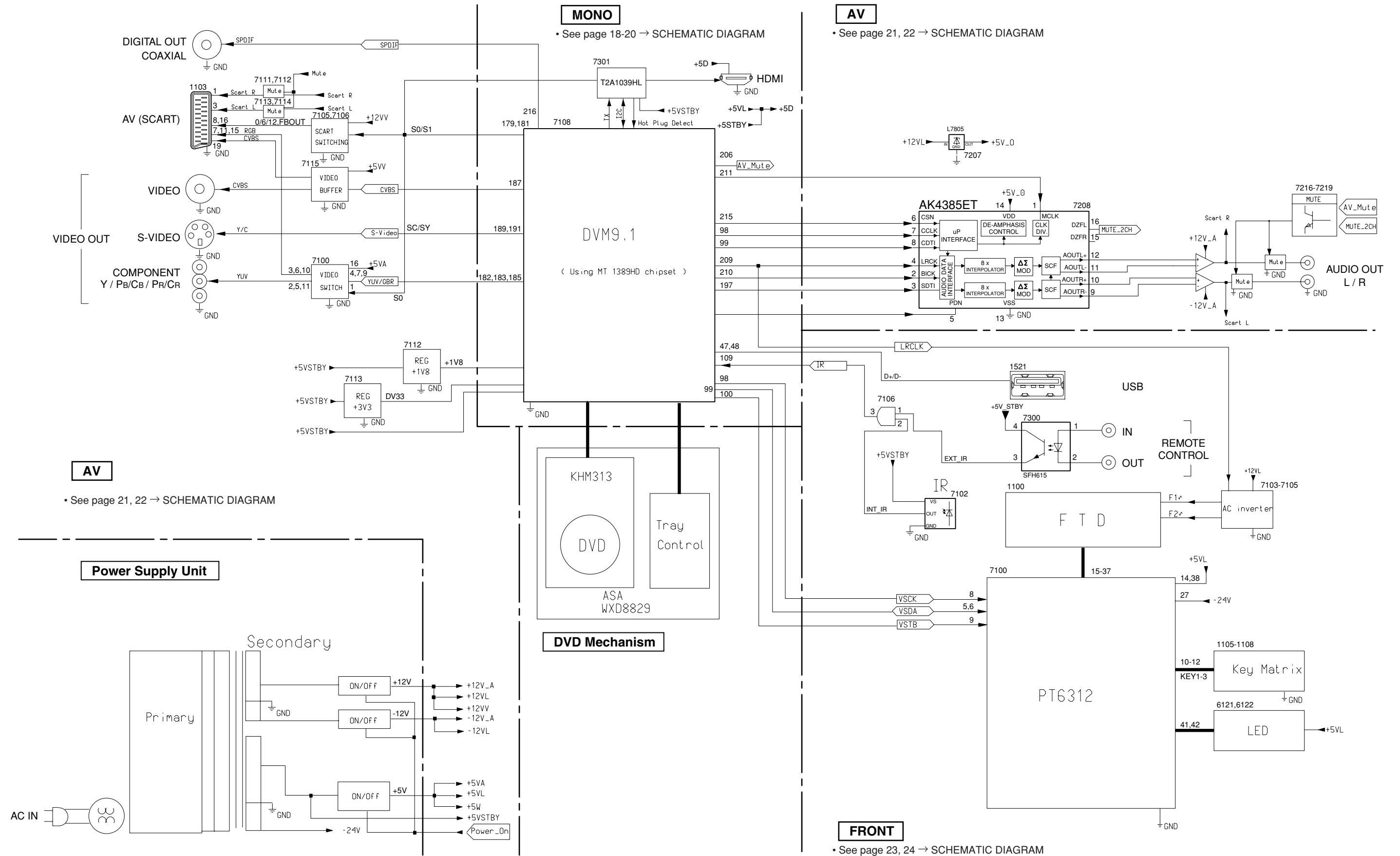

MONO

• See page 18-20 → SCHEMATIC DIAGRAM

AV

• See page 21, 22 → SCHEMATIC DIAGRAM

AV

• See page 21, 22 → SCHEMATIC DIAGRAM

Power Supply Unit

DVD Mechanism

FRONT

• See page 23, 24 → SCHEMATIC DIAGRAM

WIRING DIAGRAM

1
2
3
4
5
6
7

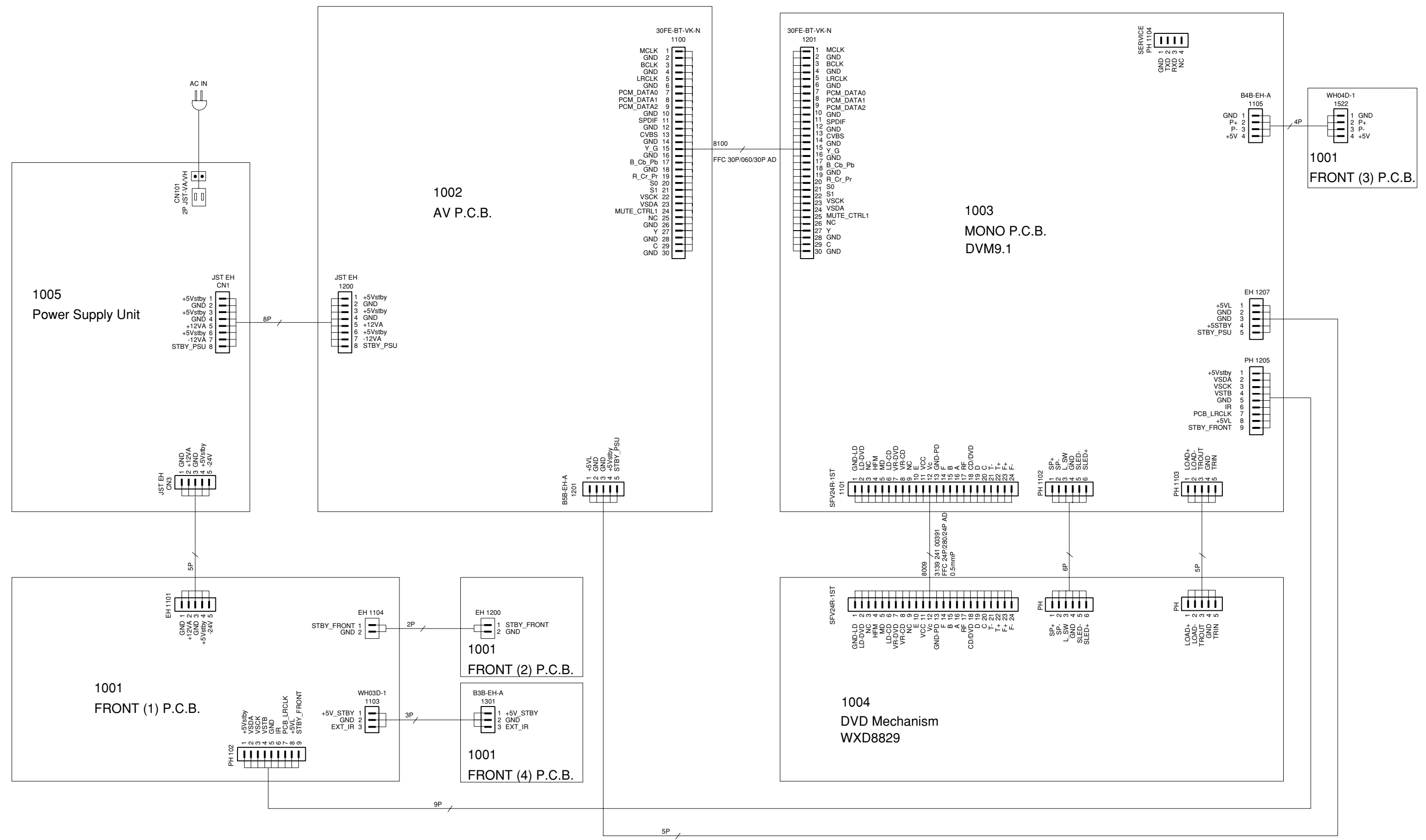

PRINTED CIRCUIT BOARDS

FOR INFORMATION ONLY (NO SERVICE PARTS WILL BE AVAILABLE)

MONO (Top view)

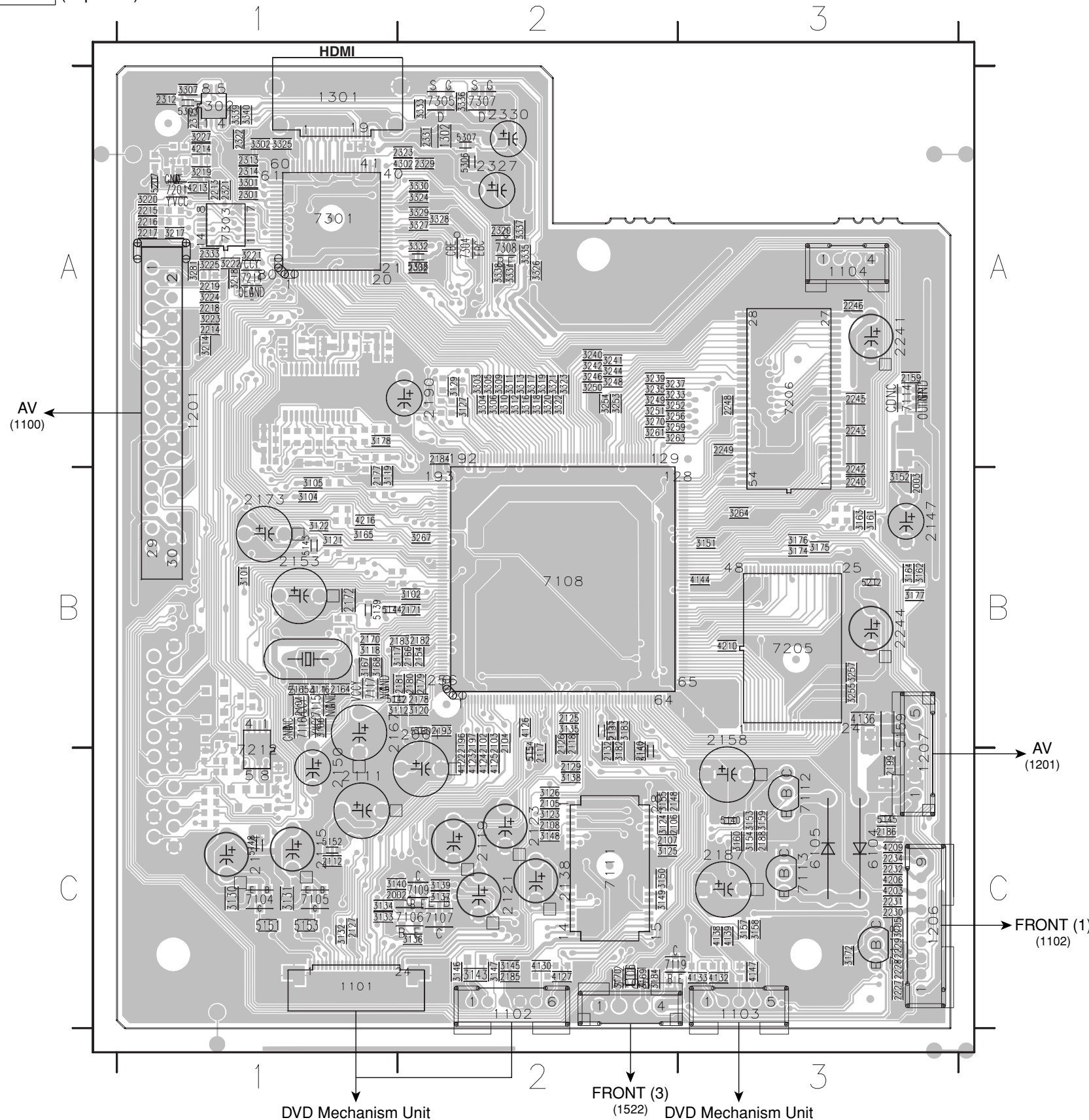

The first digit of a component indicates the component type.

1xxx : Connector 3xxx : Resistor 5xxx : Coil 7xxx : IC, Transistor, FET
2xxx : Capacitor 4xxx : SMD jumper 6xxx : Diode 9xxx : Wire jumper

1101	C1	2183	B2	3124	C2	3227	A1	3340	A1	7201	A1
1102	C2	2184	A2	3125	C2	3233	A2	4122	C2	7205	B3
1103	C3	2185	C2	3126	C2	3235	A2	4123	C2	7206	A3
1104	A3	2186	C3	3127	A2	3237	A2	4124	C2	7212	C1
1105	C2	2187	C3	3129	A2	3239	A2	4125	C2	7214	A1
1106	C2	2188	C3	3130	C1	3240	A2	4126	B2	7301	A1
1201	A1	2190	A2	3131	C1	3241	A2	4127	C2	7302	A1
1202	A1	2193	B2	3132	C1	3242	A2	4130	C2	7304	A2
1205	C3	2196	B2	3133	C1	3244	A2	4132	C3	7305	A2
1206	C3	2197	B2	3134	C1	3246	A2	4133	C3	7307	A2
1207	C3	2199	C3	3135	B2	3248	A2	4136	B3	7308	A2
1301	A1	2213	A1	3136	C2	3249	A2	4138	C3		
1302	A2	2214	A1	3137	C2	3250	A2	4139	C3		
2001	B2	2215	A1	3138	C2	3251	A2	4144	B3		
2002	C1	2216	A1	3139	C2	3252	A2	4147	C3		
2003	B3	2217	A1	3140	C1	3253	A2	4203	C3		
2101	B1	2218	A1	3143	C2	3254	A2	4206	C3		
2102	B2	2219	A1	3145	C2	3255	B3	4209	C3		
2103	B2	2227	C3	3146	C2	3256	A2	4210	B3		
2104	B2	2228	C3	3147	C2	3257	B3	4213	A1		
2105	C2	2229	C3	3148	C2	3259	A2	4214	A1		
2106	C2	2230	C3	3149	C2	3261	A2	4216	B1		
2107	C2	2231	C3	3150	C2	3263	A2	4302	A2		
2108	C2	2232	C3	3151	B3	3264	B3	5139	B1		
2111	C1	2234	C3	3152	B3	3267	B2	5140	C3		
2112	C1	2240	B3	3153	C3	3270	A2	5141	B1		
2114	C1	2241	A3	3154	C3	3281	A1	5142	B1		
2115	C1	2242	B3	3155	C2	3301	A1	5143	B1		
2117	C2	2243	A3	3157	C3	3302	A1	5144	B1		
2118	B2	2244	B3	3158	C3	3303	A2	5145	C3		
2119	C2	2245	A3	3159	C3	3304	A2	5148	C1		
2121	C2	2246	A3	3160	C3	3305	A2	5151	C1		
2123	C2	2248	A3	3161	B3	3306	A2	5152	C1		
2125	B2	2249	A3	3162	B3	3307	A1	5153	C1		
2126	B2	2301	A1	3163	B3	3309	A2	5154	C2		
2127	C1	2312	A1	3164	B3	3310	A2	5155	B2		
2129	C2	2313	A1	3165	B1	3311	A2	5157	C2		
2131	B2	2314	A1	3166	B1	3312	A2	5159	B3		
2132	C2	2315	A1	3167	B1	3313	A2	5160	B2		
2138	C2	2320	A2	3168	B1	3316	A2	5207	A1		
2140	C2	2321	A1	3169	C2	3317	A2	5212	B3		
2147	B3	2322	A1	3170	C2	3318	A2	5303	A1		
2148	C2	2323	A2	3172	C3	3319	A2	5306	A2		
2150	C1	2327	A2	3174	B3	3320	A2	5307	A2		
2153	B1	2329	A2	3175	B3	3321	A2	5308	A2		
2154	B2	2330	A2	3176	B3	3322	A2	6104	C3		
2158	B3	2331	A2	3177	B3	3323	A2	6105	C3		
2159	A3	2332	A2	3178	A1	3324	A2	7104	C1		
2164	B1	2333	A1	3182	C2	3325	A1	7105	C1		
2165	B1	3101	B1	3183	B2	3326	A2	7106	C2		
2166	B2	3102	B2	3184	C2	3327	A2	7107	C2		
2167	B1	3104	B1	3205	C3	3328	A2	7108	B2		
2170	B1	3105	B1	3214	A1	3329	A2	7109	C2		
2171	B2	3112	B2	3217	A1	3330	A2	7111	C2		
2172	B1	3116	B1	3218	A1	3331	A2	7112	C3		
2173	B1	3117	B1	3219	A1	3332	A2	7113	C3		
2177	B1	3118	B1	3220	A1	3333	A2	7114	A3		
2178	B2	3119	B1	3221	A1	3335	A2	7115	B1		
2179	B2	3120	B2	3222	A1	3336	A2	7116	B1		
2180	B2	3121	B1	3223	A1	3337	A2	7117	B1		
2181	B2	3122	B1	3224	A1	3338	A2	7118	C3		
2182	B2	3123	C2	3225	A1	3339	A1	7119	C2		

The first digit of a component indicates the component type.

1xxx : Connector 3xxx : Resistor 5xxx : Coil 7xxx : IC, Transistor, FET
 2xxx : Capacitor 4xxx : SMD jumper 6xxx : Diode 9xxx : Wire jumper

MONO (Bottom view)

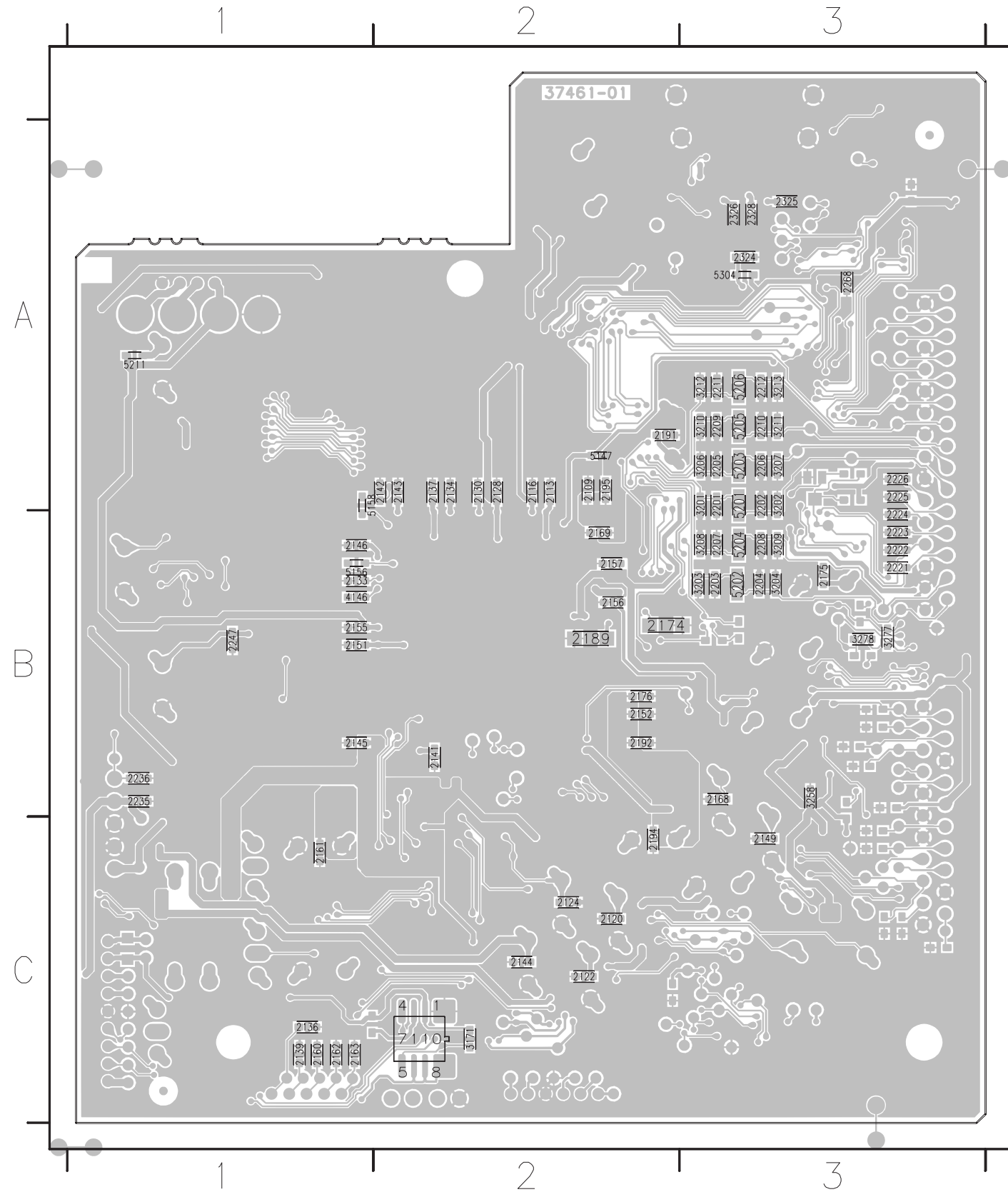

2109	A2	2325	A3
2113	A2	2326	A3
2116	A2	2328	A3
2120	C2	3171	C2
2122	C2	3201	A3
2124	C2	3202	A3
2128	A2	3203	B3
2130	A2	3204	B3
2133	B1	3206	A3
2134	A2	3207	A3
2136	C1	3208	B3
2137	A2	3209	B3
2139	C1	3210	A3
2141	B2	3211	A3
2142	A2	3212	A3
2143	A2	3213	A3
2144	C2	3258	B3
2145	B1	3277	B3
2146	B1	3278	B3
2149	C3	4146	B1
2151	B1	5147	A2
2152	B2	5156	B1
2155	B1	5158	A1
2156	B2	5201	A3
2157	B2	5202	B3
2160	C1	5203	A3
2161	C1	5204	B3
2162	C1	5205	A3
2163	C1	5206	A3
2168	B3	5211	A1
2169	B2	5304	A3
2174	B2	7110	C2
2175	B3		
2176	B2		
2176	B2		
2189	B2		
2191	A2		
2192	B2		
2194	C2		
2195	A2		
2201	A3		
2202	A3		
2203	B3		
2204	B3		
2205	A3		
2206	A3		
2207	B3		
2208	B3		
2209	A3		
2210	A3		
2211	A3		
2212	A3		
2221	B3		
2222	B3		
2223	B3		
2224	B3		
2225	A3		
2226	A3		
2235	B1		
2236	B1		
2247	B1		
2268	A3		
2324	A3		

The first digit of a component indicates the component type.

1xxx : Connector 3xxx : Resistor 5xxx : Coil 7xxx : IC, Transistor, FET
 2xxx : Capacitor 4xxx : SMD jumper 6xxx : Diode 9xxx : Wire jumper

AV (Top view)

1100 D11	1103 B3	1202 A9	2105 E5	2127 C4	2134 D5	2137 B8	2202 F10	2209 D2	2221 B10
1101 A8	1200 G9	2101 D8	2112 C5	2129 C4	2135 D8	2138 B6	2204 D10	2210 D3	7207 D9
1102 A6	1201 F11	2103 D4	2124 C3	2131 C4	2136 C7	2200 F9	2207 D10	2215 B9	

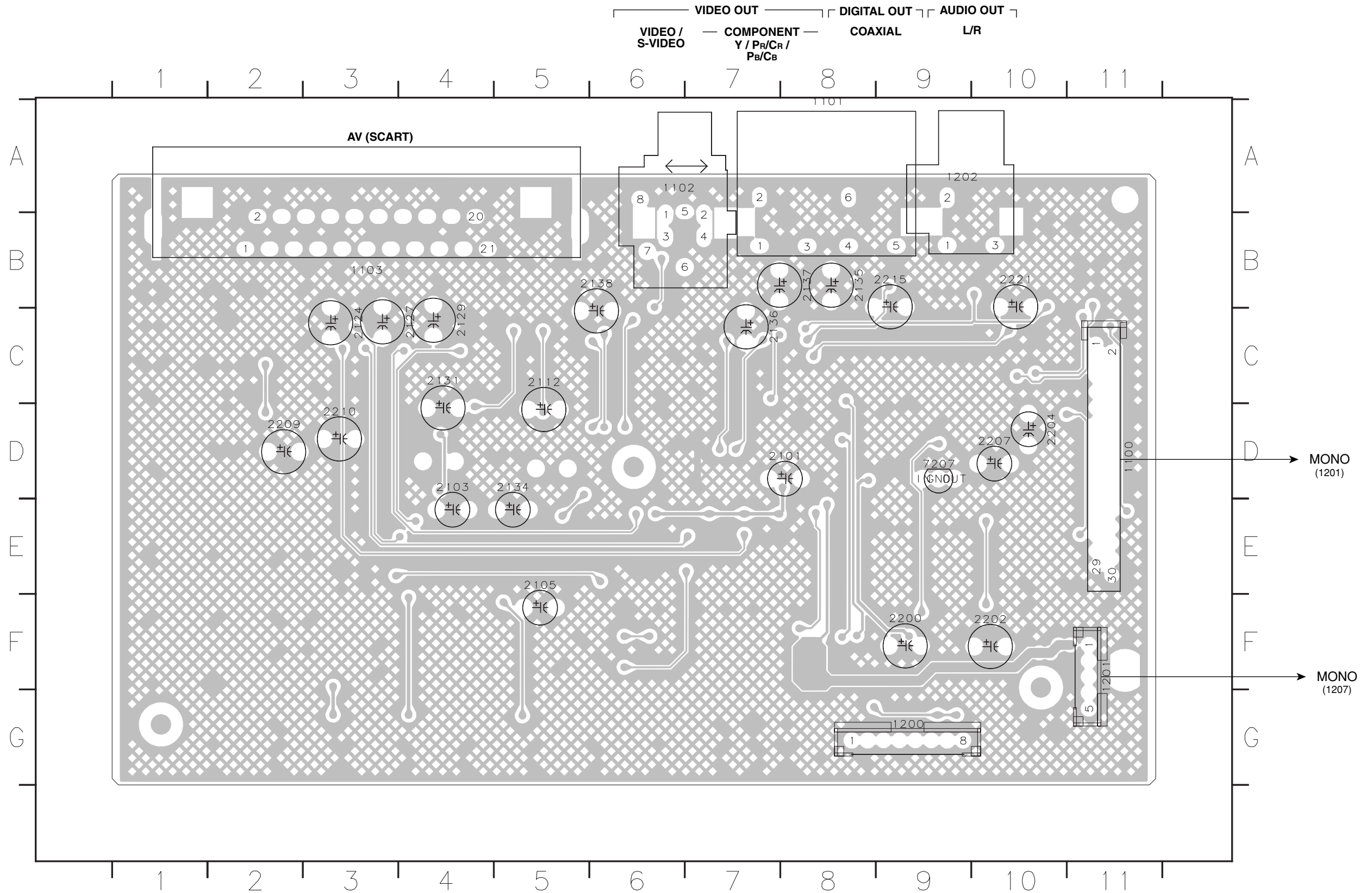

The first digit of a component indicates the component type.

- 1xxx : Connector
- 2xxx : Capacitor
- 3xxx : Resistor
- 4xxx : SMD jumper
- 5xxx : Coil
- 6xxx : Diode
- 7xxx : IC, Transistor, FET
- 8xxx : Wire jumper
- 9xxx : Wire jumper

AV (Bottom view)

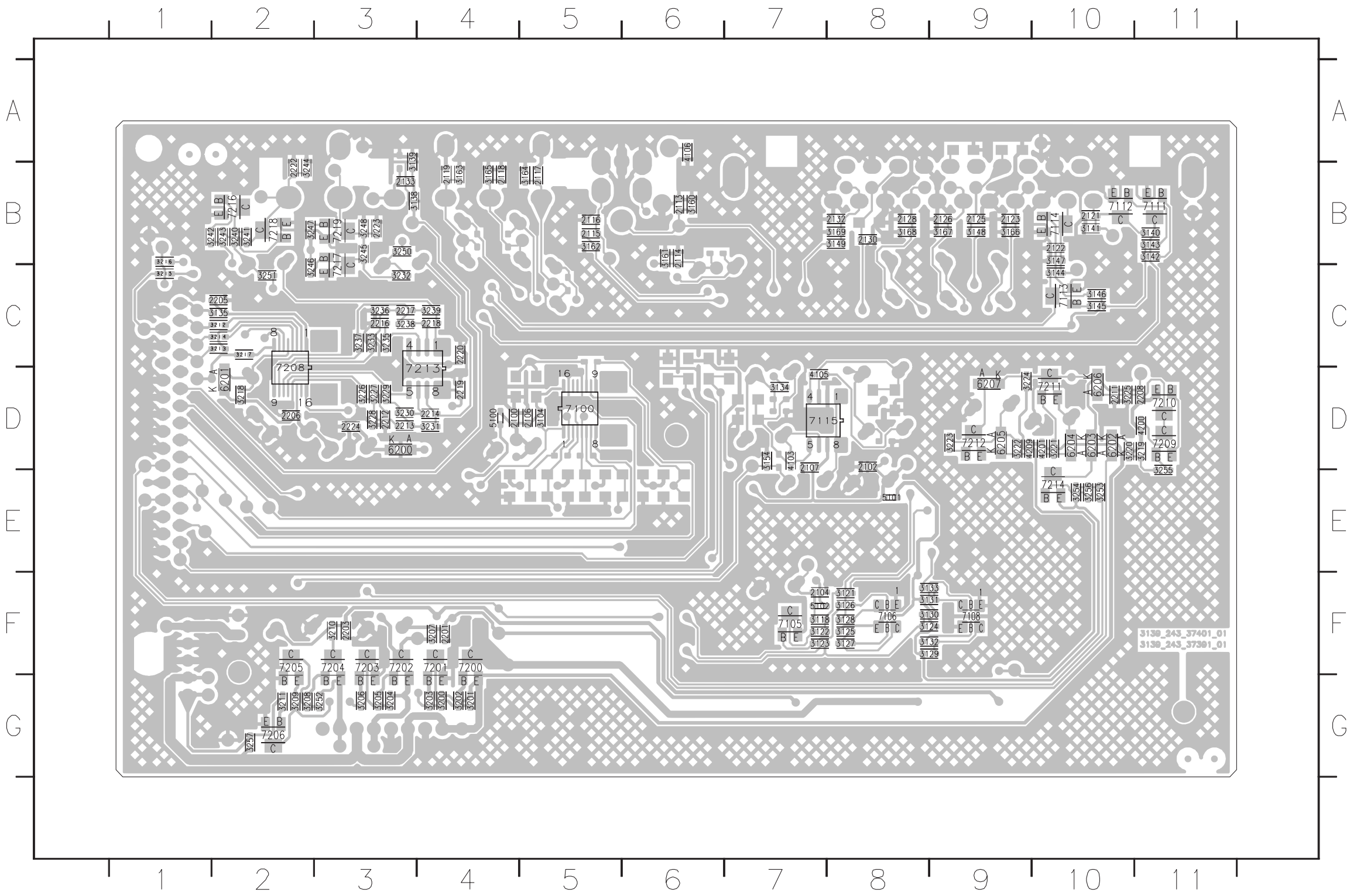

1	2	3	4	5	6	7	8	9	10	11
1	2	3	4	5	6	7	8	9	10	11
1	2	3	4	5	6	7	8	9	10	11
1	2	3	4	5	6	7	8	9	10	11
1	2	3	4	5	6	7	8	9	10	11
1	2	3	4	5	6	7	8	9	10	11
1	2	3	4	5	6	7	8	9	10	11
1	2	3	4	5	6	7	8	9	10	11
1	2	3	4	5	6	7	8	9	10	11
1	2	3	4	5	6	7	8	9	10	11
1	2	3	4	5	6	7	8	9	10	11
1	2	3	4	5	6	7	8	9	10	11
1	2	3	4	5	6	7	8	9	10	11
1	2	3	4	5	6	7	8	9	10	11
1	2	3	4	5	6	7	8	9	10	11
1	2	3	4	5	6	7	8	9	10	11
1	2	3	4	5	6	7	8	9	10	11
1	2	3	4	5	6	7	8	9	10	11
1	2	3	4	5	6	7	8	9	10	11
1	2	3	4	5	6	7	8	9	10	11
1	2	3	4	5	6	7	8	9	10	11

The first digit of a component indicates the component type.

- 1xxx : Connector 3xxx : Resistor 5xxx : Coil 7xxx : IC, Transistor, FET
- 2xxx : Capacitor 4xxx : SMD jumper 6xxx : Diode 9xxx : Wire jumper

FRONT (1) (Top view)

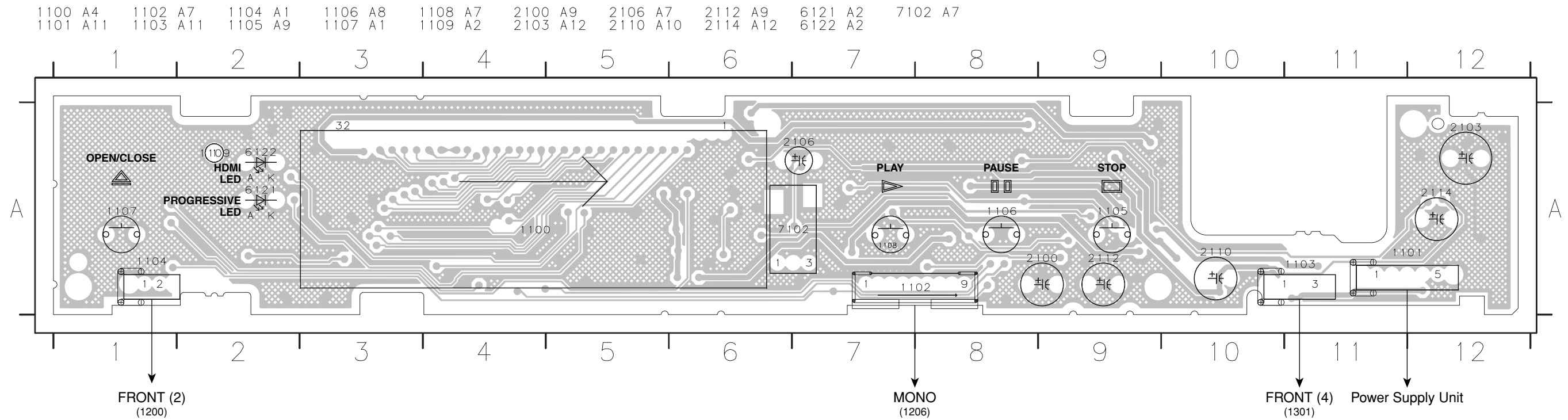

FRONT (1) (Bottom view)

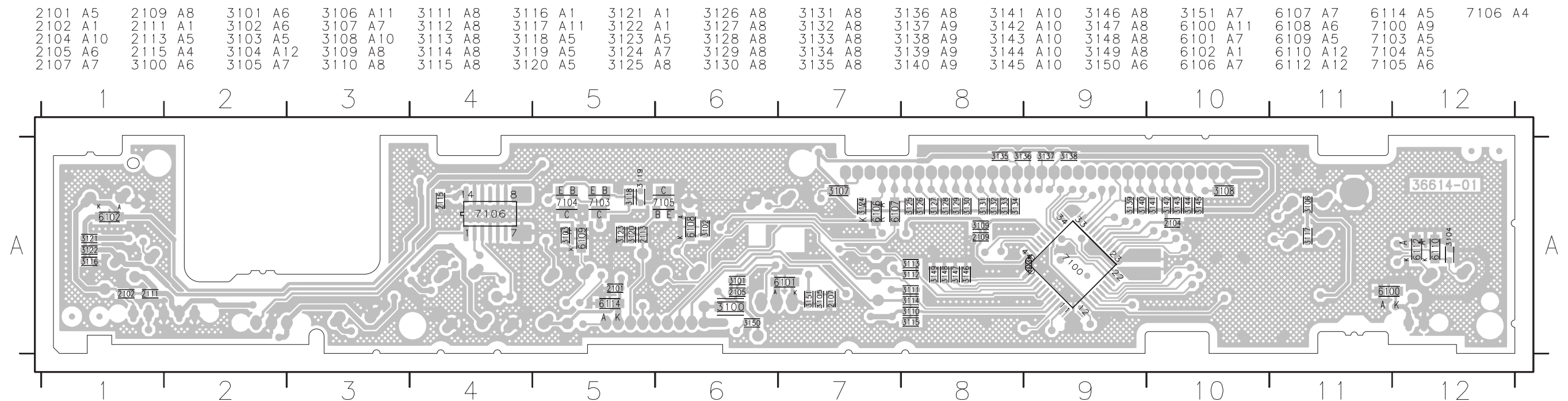

The first digit of a component indicates the component type.

1xxx : Connector 3xxx : Resistor 5xxx : Coil 7xxx : IC, Transistor, FET
 2xxx : Capacitor 4xxx : SMD jumper 6xxx : Diode 9xxx : Wire jumper

FRONT (2) (Top view)

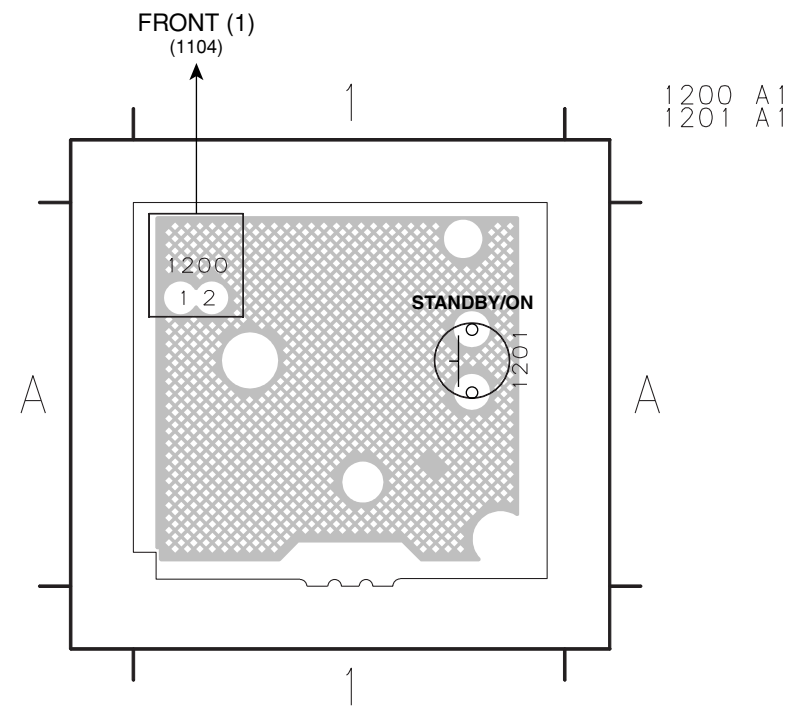

FRONT (3) (Top view)

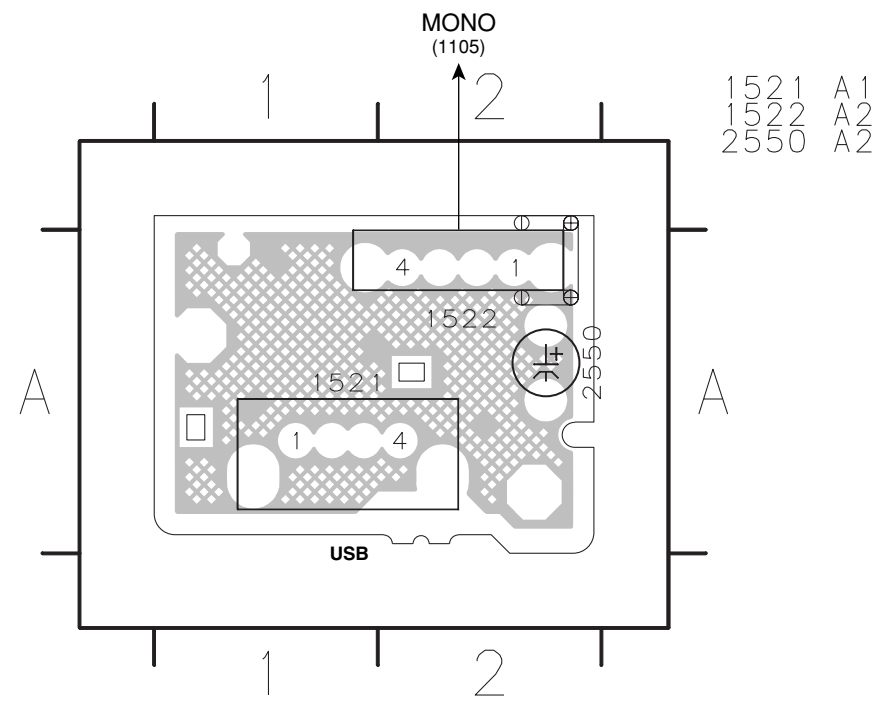

FRONT (4) (Top view)

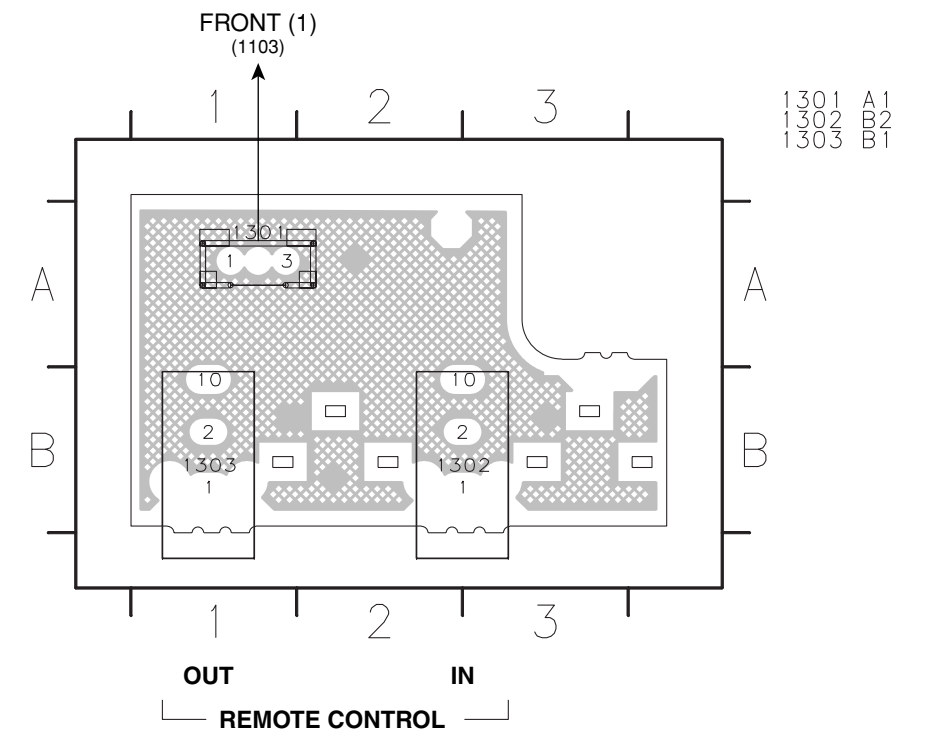

FRONT (2) (Bottom view)

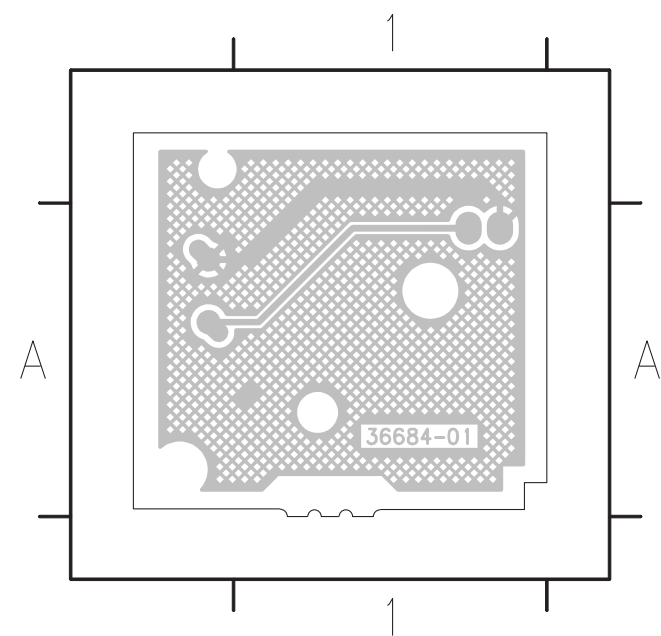

FRONT (3) (Bottom view)

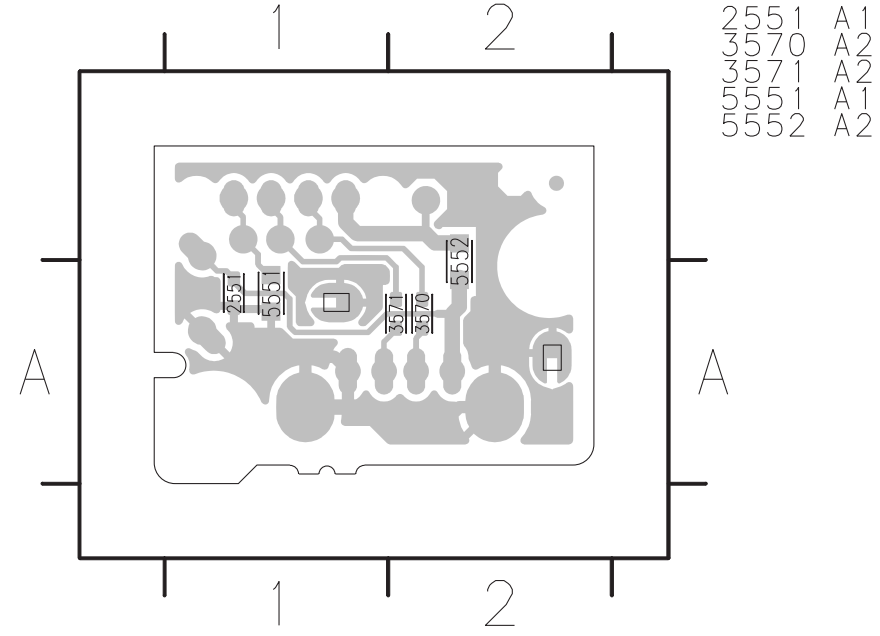

FRONT (4) (Bottom view)

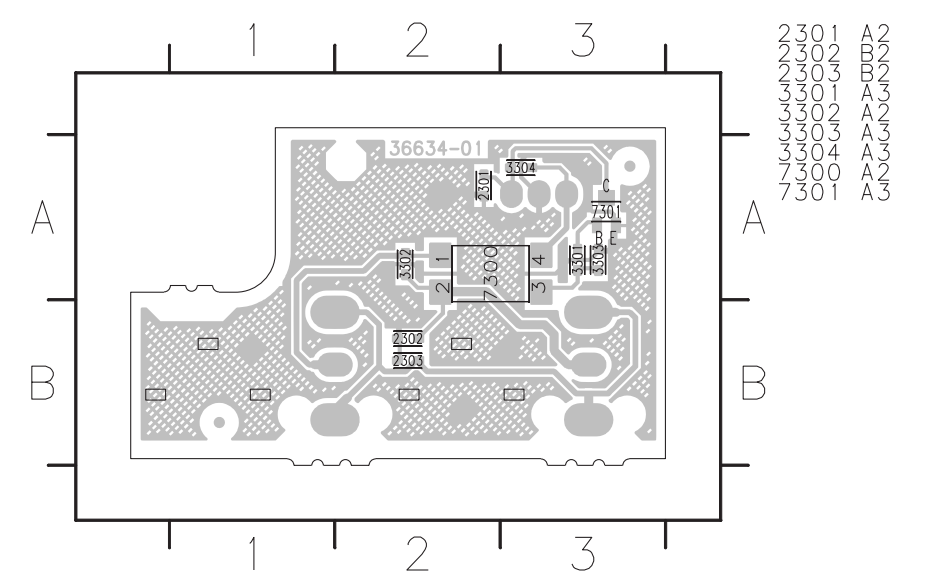

SCHEMATIC DIAGRAMS

FOR INFORMATION ONLY (NO SERVICE PARTS WILL BE AVAILABLE)

MONO 1/3

The first digit of a component indicates the component type.

- 1xxx : Connector
- 2xxx : Capacitor
- 3xxx : Resistor
- 4xxx : SMD jumper
- 5xxx : Coil
- 6xxx : Diode
- 7xxx : IC, Transistor, FET
- 8xxx : Diode
- 9xxx : Wire jumper

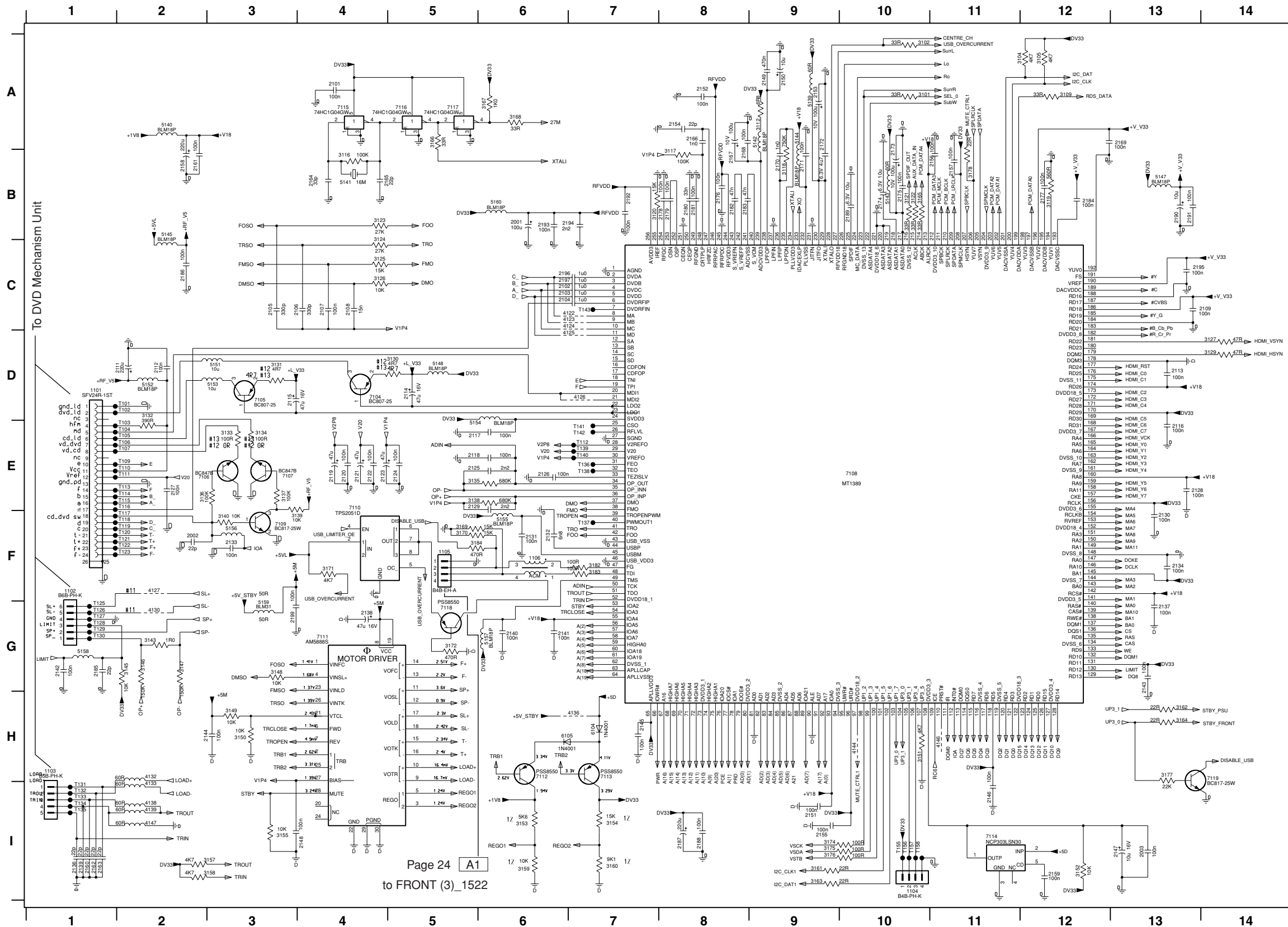

1101 D1	3121 B10	T111 E2
1102 F1	3122 B10	T112 E7
1103 H1	3123 B4	T113 E2
1104 I10	3124 C4	T114 E2
1105 F5	3125 C4	T115 E2
1106 F6	3126 C4	T116 E2
2001 B6	3127 D14	T117 F2
2002 F2	3128 D14	T118 F2
2003 I13	3130 D5	T119 F2
2101 A4	3131 D3	T120 F2
2102 C6	3132 D2	T121 F2
2103 C6	3133 E3	T122 F2
2104 C6	3134 E3	T123 F2
2105 C3	3135 E5	T125 G1
2106 C4	3136 E2	T126 G1
2107 C4	3137 E3	T127 G1
2108 C4	3138 E5	T128 G1
2109 C14	3139 F3	T129 G1
2111 D2	3140 F3	T130 G1
2112 D2	3143 G2	T131 I1
2113 D13	3145 G2	T132 I1
2114 D5	3146 G2	T133 I1
2115 D3	3147 G2	T134 I1
2116 E13	3148 G3	T135 I1
2117 E5	3149 H3	T136 E7
2118 E5	3150 H3	T137 F7
2119 E4	3151 H10	T138 E7
2120 E4	3152 I12	T139 E7
2121 E4	3153 I6	T140 E7
2122 E4	3154 I7	T141 E7
2123 E4	3155 I3	T142 E7
2124 E5	3157 I3	T143 C7
2125 E5	3158 I3	T155 I10
2126 E6	3159 I6	T156 I10
2127 E2	3160 I7	T157 I10
2128 E13	3161 I9	T158 I10
2129 E5	3162 H3	
2130 F13	3163 I9	
2131 F6	3164 H13	
2132 F6	3165 B10	
2133 F3	3166 A5	
2134 F13	3167 A6	
2136 I1	3168 A5	
2137 G13	3169 F5	
2138 G4	3170 F5	
2139 I1	3171 F4	
2140 G6	3172 G5	
2141 G6	3174 I9	
2142 G1	3175 I9	
2143 G13	3176 I9	
2144 H3	3177 H13	
2145 H7	3178 B11	
2146 I11	3182 F7	
2147 I13	3183 F7	
2148 I4	3184 F5	
2149 A9	4122 C7	
2150 A9	4123 C7	
2151 I9	4124 C7	
2152 A8	4125 D7	
2153 A9	4126 D7	
2154 A8	4127 F2	
2155 I9	4130 G2	
2156 B10	4132 H2	
2157 B11	4133 I2	
2158 B2	4136 H7	
2159 I12	4139 I2	
2160 I1	4139 I2	
2161 B2	4144 H10	
2162 I1	4146 H11	
2163 I1	4147 I2	
2164 B4	5139 A9	
2165 B5	5140 A2	
2166 A8	5141 B4	
2167 B8	5142 A9	
2168 B8	5143 B10	
2169 A13	5144 A9	
2170 B9	5145 A9	
2171 B9	5147 B13	
2172 A9	5148 D5	
2173 B10	5151 D3	
2174 B10	5152 D2	
2175 B10	5153 D3	
2176 B8	5154 D5	
2177 B12	5155 F6	
2178 B8	5156 F3	
2179 B8	5157 G6	
2180 B8	5158 G1	
2181 B8	5159 G3	
2182 B8	5160 B6	
2183 B8	6104 H7	
2184 B12	6105 H6	
2185 G1	7104 D4	
2186 C2	7105 D3	
2187 I8	7106 E2	
2188 I8	7107 E2	
2189 B10	7108 E10	
2190 B13	7109 F3	
2191 B13	7110 E4	
2192 B7	7111 G4	
2193 B6	7112 H6	
2194 B6	7113 H7	
2195 C13	7114 H11	
2196 C6	7115 A4	
2197 C6	7116 A5	
2199 G3	7117 A5	
3101 A10	7118 G5	
3102 A10	7119 H14	
3104 A12	T101 D2	
3105 A12	T102 D2	
3109 A12	T103 E2	
3112 A9	T104 E2	
3116 B4	T105 E2	
3117 B8	T106 E2	
3118 B9	T107 E2	
3119 B12	T109 E2	
3120 B7	T110 E2	

Page 24 A1 to FRONT (3)_1522

★ Components having special characteristics are marked Δ and must be replaced with parts having specifications equal to those originally installed.
 ★ Schematic diagram is subject to change without notice.

The first digit of a component indicates the component type.

1xxx : Connector 3xxx : Resistor 5xxx : Coil 7xxx : IC, Transistor, FET
 2xxx : Capacitor 4xxx : SMD jumper 6xxx : Diode 9xxx : Wire jumper

MONO 2/3

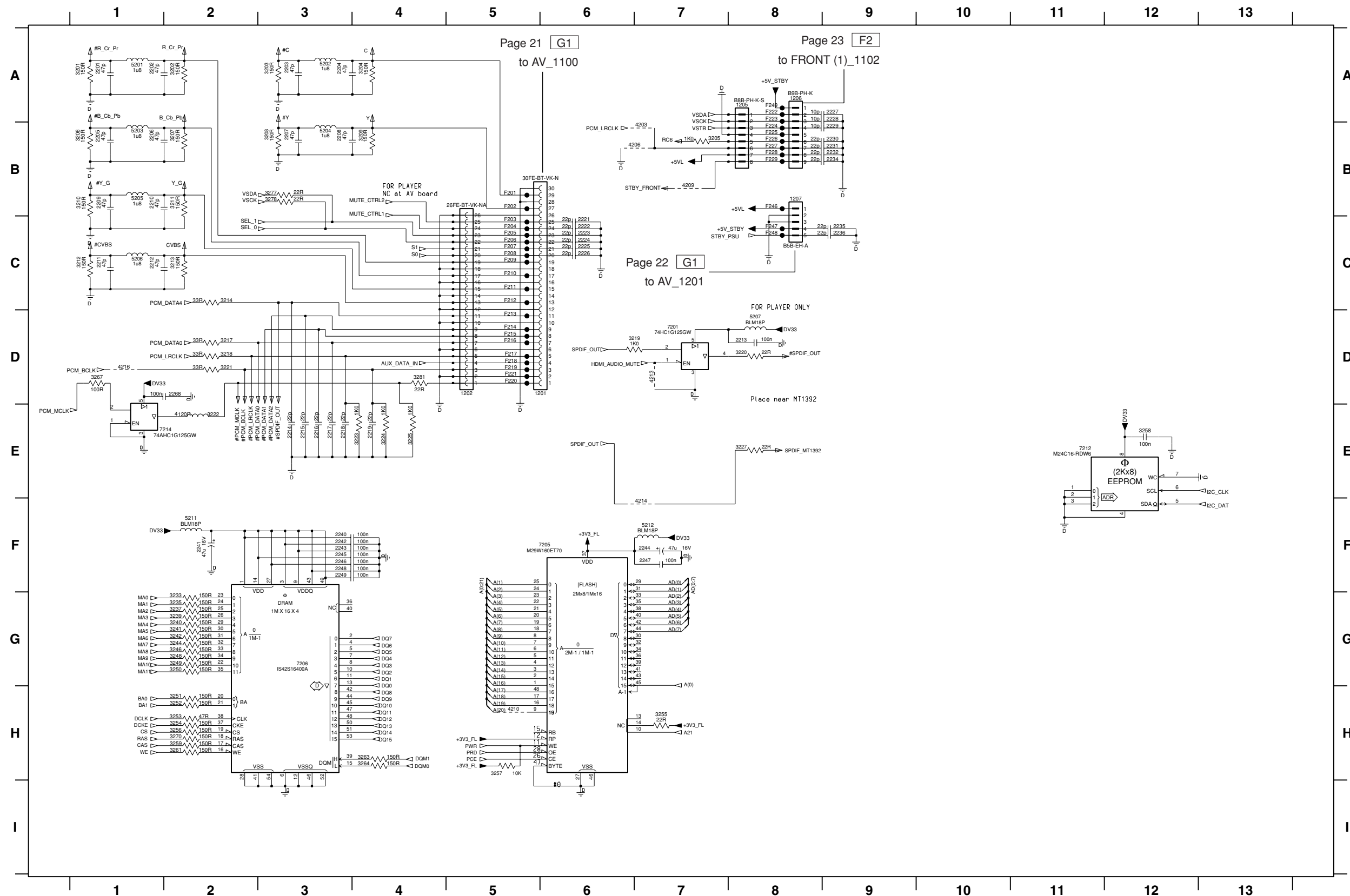

1201 D6	4203 B7
1202 D6	4206 B7
1204 A11	4209 B7
1205 A8	4210 H5
1206 A8	4213 D7
1207 B8	4214 F7
1208 A12	4216 D1
2201 A1	5201 A1
2202 A1	5202 A3
2203 A3	5203 B1
2204 A3	5204 B3
2205 B1	5205 B1
2206 B1	5206 C1
2207 B3	5207 D8
2208 B3	5211 F2
2209 B1	5212 F7
2210 B1	7201 D7
2211 C1	7205 F5
2212 C1	7206 G3
2213 D8	7212 E11
2214 E3	7214 E2
2215 E3	F201 B5
2216 E3	F202 B5
2217 E3	F203 C5
2218 E3	F204 C5
2219 E4	F205 C5
2221 C6	F206 C5
2222 C6	F207 C5
2223 C6	F208 C5
2224 C6	F209 C5
2225 C6	F210 C5
2226 C6	F211 C5
2227 A9	F212 C5
2228 A9	F213 D5
2229 B9	F214 D5
2230 B9	F215 D5
2231 B9	F216 D5
2232 B9	F217 D5
2234 B9	F218 D5
2235 C9	F219 D5
2236 C9	F220 D5
2240 F3	F221 D5
2241 F2	F222 A8
2242 F3	F223 A8
2243 F3	F224 B8
2244 F7	F225 B8
2245 F3	F226 B8
2246 F3	F227 B8
2247 F7	F228 B8
2248 F3	F229 B8
2249 F3	F230 A12
2266 B13	F231 A12
2267 B13	F232 A12
2268 D2	F233 B12
2269 A13	F234 B12
3201 A1	F235 B12
3202 A2	F236 B12
3203 A3	F237 B12
3204 A4	F238 C12
3205 B7	F239 B12
3206 B1	F240 B12
3207 B2	F241 B12
3208 B3	F242 B12
3209 B4	F243 B12
3210 B1	F244 C11
3211 B2	F245 B12
3212 C1	F246 B8
3213 C2	F247 C8
3214 C2	F248 C8
3217 D2	F249 A8
3218 D2	
3219 D7	
3220 D8	
3221 D2	
3222 E2	
3223 E4	
3224 E4	
3225 E4	
3227 E8	
3233 G2	
3235 G2	
3237 G2	
3239 G2	
3240 G2	
3241 G2	
3242 G2	
3244 G2	
3246 G2	
3248 G2	
3249 G2	
3250 G2	
3251 H2	
3252 H2	
3253 H2	
3254 H2	
3255 H7	
3256 H2	
3257 H5	
3258 E12	
3259 H2	
3261 H2	
3263 H4	
3264 H4	
3267 D1	
3270 H2	
3277 B3	
3278 B3	
3281 D4	

* Components having special characteristics are marked Δ and must be replaced with parts having specifications equal to those originally installed.
 * Schematic diagram is subject to change without notice.

MONO 3/3

The first digit of a component indicates the component type.

1xxx : Connector 3xxx : Resistor 5xxx : Coil 7xxx : IC, Transistor, FET
 2xxx : Capacitor 4xxx : SMD jumper 6xxx : Diode 9xxx : Wire jumper

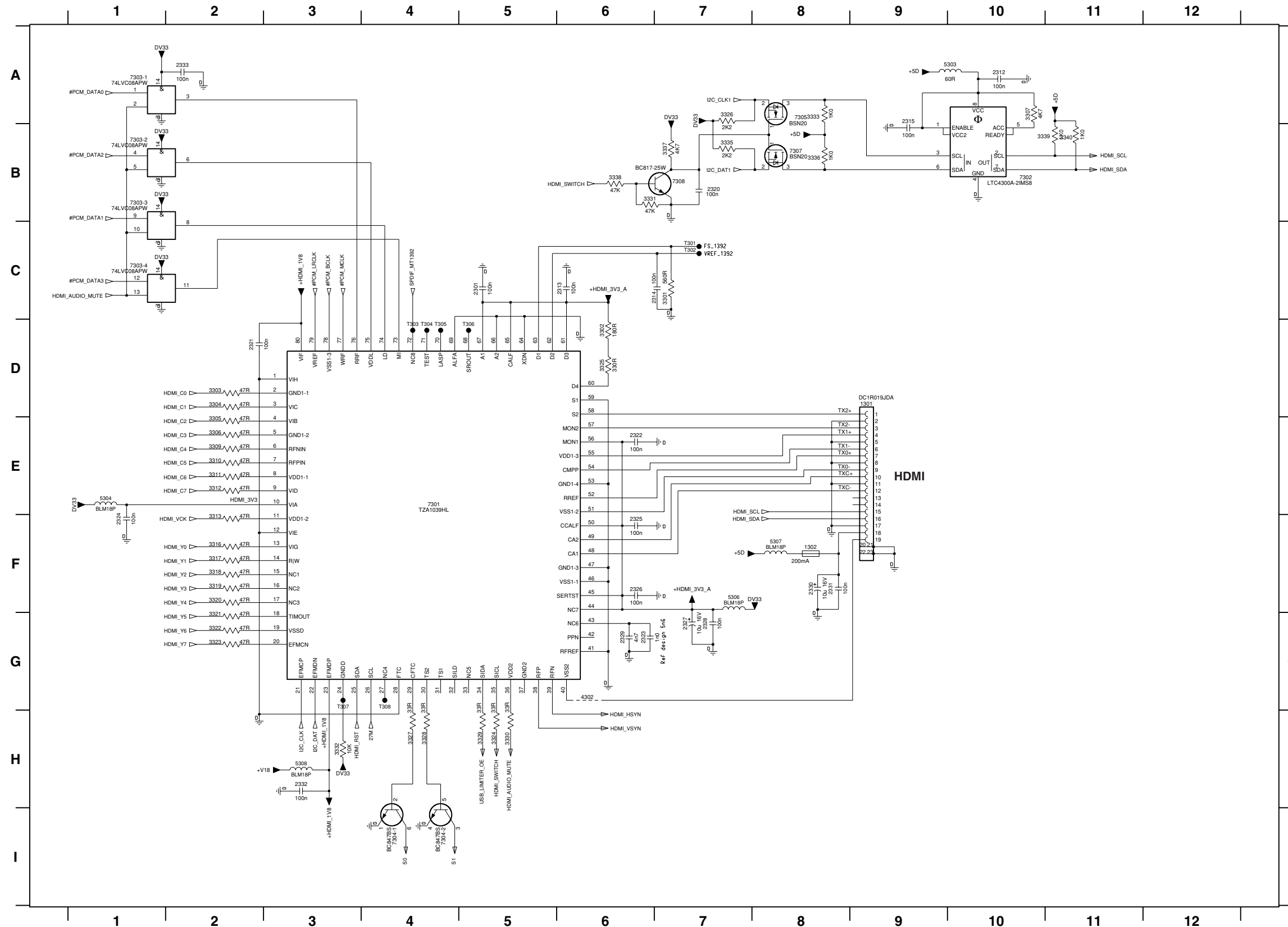

- 1301 D9
- 1302 F8
- 2301 C5
- 2312 A10
- 2313 C6
- 2314 C7
- 2315 A9
- 2320 B7
- 2321 D2
- 2322 E6
- 2323 G6
- 2324 F1
- 2325 F6
- 2326 F6
- 2327 G7
- 2328 G7
- 2329 G6
- 2330 F8
- 2331 F8
- 2332 H3
- 2333 A2
- 3301 C7
- 3302 D6
- 3303 D2
- 3304 D2
- 3305 E2
- 3306 E2
- 3307 A10
- 3309 E2
- 3310 E2
- 3311 E2
- 3312 E2
- 3313 F2
- 3316 F2
- 3317 F2
- 3318 F2
- 3319 F2
- 3320 F2
- 3321 G2
- 3322 G2
- 3323 G2
- 3324 H5
- 3325 D6
- 3326 A7
- 3327 H4
- 3328 H4
- 3329 H5
- 3330 H5
- 3331 B6
- 3332 H3
- 3333 A8
- 3335 B7
- 3336 B8
- 3337 B7
- 3338 B6
- 3339 B10
- 3340 B11
- 4302 G6
- 5303 A10
- 5304 E1
- 5306 F7
- 5307 F8
- 5308 H3
- 7301 E4
- 7302 B10
- 7303-1 A1
- 7303-2 B1
- 7303-3 B1
- 7303-4 C1
- 7304-1 I4
- 7304-2 I4
- 7305 A8
- 7307 B8
- 7308 B7
- T301 C7
- T302 C7
- T303 D4
- T304 D4
- T305 D4
- T306 D5
- T307 G3
- T308 G4

★ Components having special characteristics are marked Δ and must be replaced with parts having specifications equal to those originally installed.
 ★ Schematic diagram is subject to change without notice.

The first digit of a component indicates the component type.

1xxx : Connector 3xxx : Resistor 5xxx : Coil 7xxx : IC, Transistor, FET
 2xxx : Capacitor 4xxx : SMD jumper 6xxx : Diode 9xxx : Wire jumper

AV 1/2

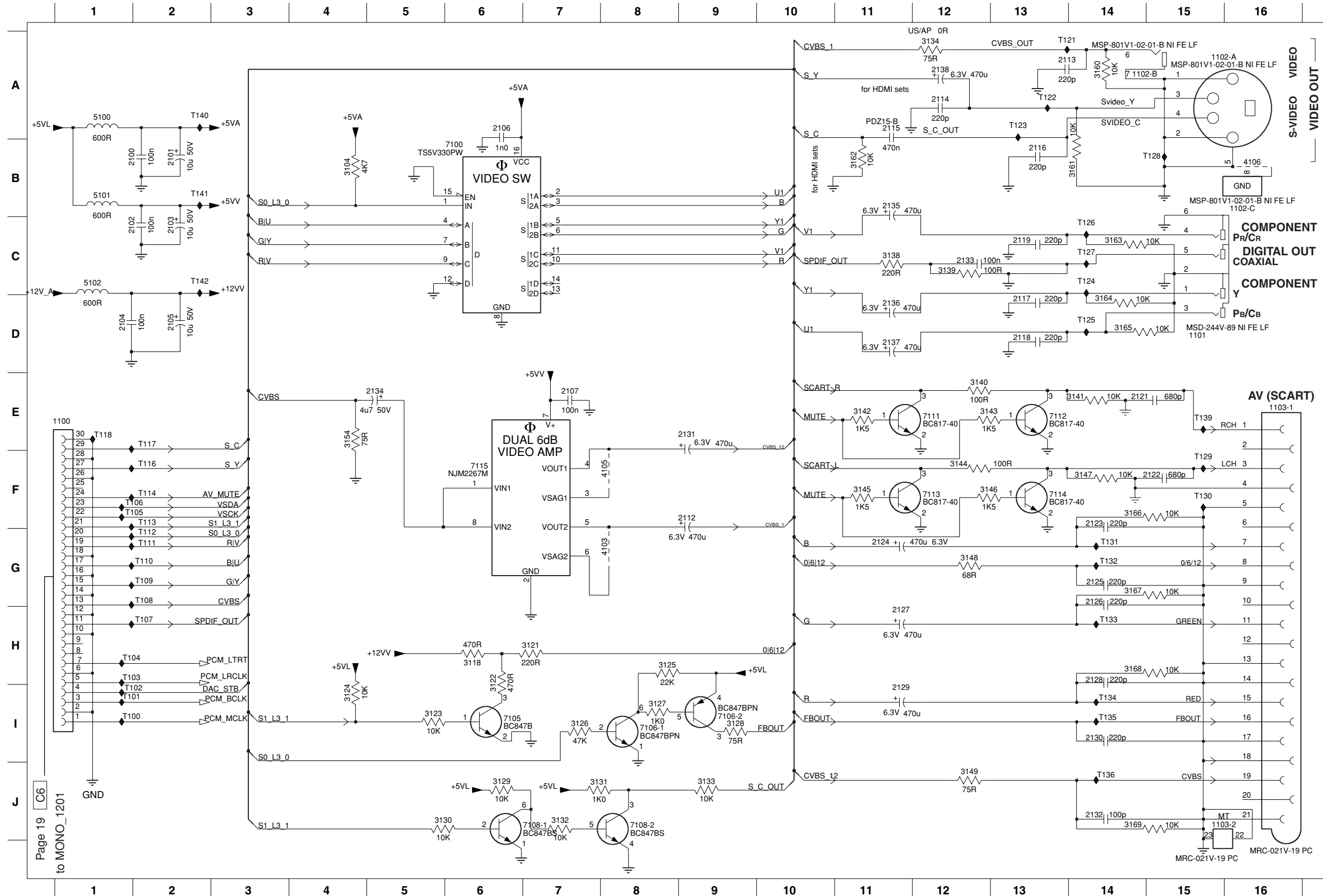

1100 E1	5102 C1
1101 D16	7100 B6
1102-A A16	7105 I6
1102-B A14	7106-1 I8
1102-C B16	7106-2 I9
1103-1 E16	7108-1 J7
1103-2 J15	7108-2 J8
2100 B2	7111 E12
2101 B2	7112 E13
2102 C2	7113 F12
2103 C2	7114 F13
2104 D1	7115 F6
2105 D2	7100 I1
2106 A6	7101 I1
2107 E7	7102 I2
2112 F9	7103 H1
2113 A13	7104 H1
2114 A12	7105 F2
2115 A11	7106 F2
2116 B13	7107 H2
2117 D13	7108 G2
2118 D13	7109 G2
2119 C13	7110 G2
2121 E14	7111 G2
2122 F15	7112 G2
2123 F14	7113 F2
2124 G11	7114 F2
2125 G14	7116 F2
2126 G14	7117 E2
2127 H11	7118 E1
2128 H14	7121 A13
2129 I11	7122 A13
2130 I14	7123 A13
2131 E9	7124 C14
2132 J14	7125 D14
2133 C12	7126 C14
2134 E5	7127 C14
2135 B11	7128 B15
2136 D11	7129 F15
2137 D11	7130 F15
2138 A12	7131 G14
3104 B4	7132 G14
3118 H6	7133 H14
3121 H7	7134 I14
3122 H6	7135 I14
3123 I5	7136 J14
3124 I4	7139 E15
3125 H8	7140 A2
3126 I7	7141 B2
3127 I8	7142 C2
3128 I9	
3129 J6	
3130 J5	
3131 J7	
3132 J7	
3133 J9	
3134 A12	
3138 C11	
3139 C12	
3140 E12	
3141 E14	
3142 E11	
3143 E12	
3144 F12	
3145 F11	
3146 F12	
3147 F14	
3148 G12	
3149 J12	
3154 E4	
3160 A14	
3161 B14	
3162 B11	
3163 C14	
3164 D14	
3165 D14	
3166 F14	
3167 G14	
3168 H14	
3169 J14	
4103 G8	
4105 F8	
4106 B16	
5100 A1	
5101 B1	

* Components having special characteristics are marked with a triangle and must be replaced with parts having specifications equal to those originally installed.
 * Schematic diagram is subject to change without notice.

The first digit of a component indicates the component type.

1xxx : Connector 3xxx : Resistor 5xxx : Coil 7xxx : IC, Transistor, FET
 2xxx : Capacitor 4xxx : SMD jumper 6xxx : Diode 9xxx : Wire jumper

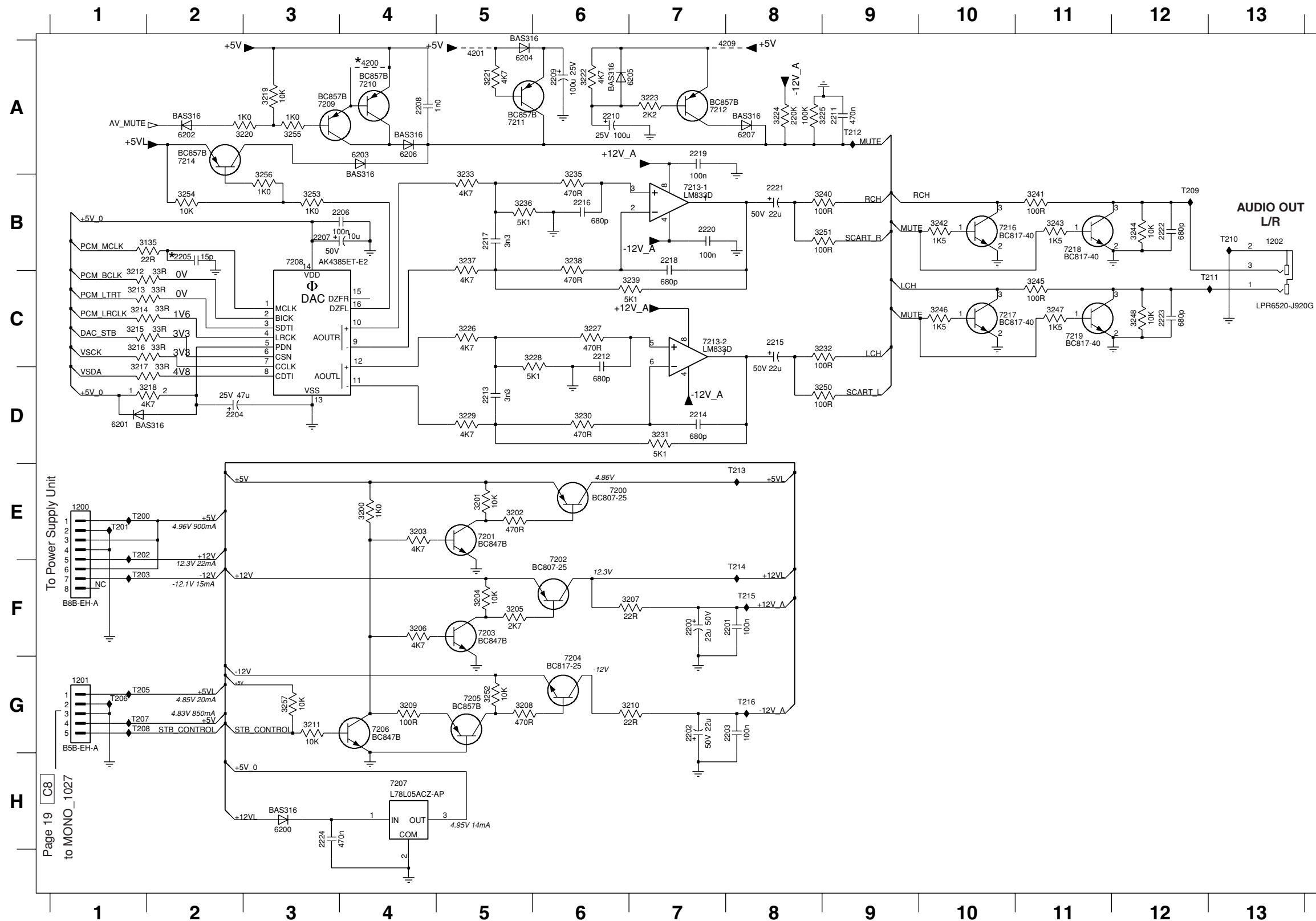

- 1200 E1
- 1201 G1
- 1202 B13
- 2200 F7
- 2201 F8
- 2202 G7
- 2203 G8
- 2204 D2
- 2205 B2
- 2206 B4
- 2207 B3
- 2208 A4
- 2209 A6
- 2210 A6
- 2211 A9
- 2212 C6
- 2213 D5
- 2214 D7
- 2215 C8
- 2216 B6
- 2217 B5
- 2218 B7
- 2219 A7
- 2220 B7
- 2221 B8
- 2222 B12
- 2223 C12
- 2224 H3
- 3135 B2
- 3200 E4
- 3201 E5
- 3202 E5
- 3203 E4
- 3204 F5
- 3205 F5
- 3206 F4
- 3207 F7
- 3208 G5
- 3209 G4
- 3210 G7
- 3211 G3
- 3212 C1
- 3213 C1
- 3214 C1
- 3215 C1
- 3216 C1
- 3217 D1
- 3218 D2
- 3219 A3
- 3220 A3
- 3221 A5
- 3222 A6
- 3223 A7
- 3224 A8
- 3225 A8
- 3226 C5
- 3227 C6
- 3228 C6
- 3229 D5
- 3230 D6
- 3231 D7
- 3232 C9
- 3233 B5
- 3235 B6
- 3236 B5
- 3237 B5
- 3238 B6
- 3239 C7
- 3240 B9
- 3241 B11
- 3242 B10
- 3243 B11
- 3244 B12
- 3245 C11
- 3246 C10
- 3247 C11
- 3248 C12
- 3250 D9
- 3251 B9
- 3252 G5
- 3253 B3
- 3254 B2
- 3255 A3
- 3256 B3
- 3257 G3
- 4200 A4
- 4201 A5
- 4209 A8
- 6200 H3
- 6201 D1
- 6202 A2
- 6203 A4
- 6204 A5
- 6205 A6
- 6206 A4
- 6207 A8
- 7200 E6
- 7201 E5
- 7202 F6
- 7203 F5
- 7204 G6
- 7205 G5
- 7206 G4
- 7207 H4
- 7208 B3
- 7209 A3
- 7210 A4
- 7211 A5
- 7212 A7
- 7213-1 B7
- 7213-2 C7
- 7214 A2
- 7216 B10
- 7217 C10
- 7218 B11
- 7219 C11
- T200 E1
- T201 E1
- T202 E1
- T203 F1
- T205 G1
- T206 G1
- T207 G1
- T208 G1
- T209 B12
- T210 B13
- T211 C13
- T212 A9
- T213 E8
- T214 F8
- T215 F8
- T216 G8

* OPTION

★ Components having special characteristics are marked Δ and must be replaced with parts having specifications equal to those originally installed.
 ★ Schematic diagram is subject to change without notice.

The first digit of a component indicates the component type.

1xxx : Connector 3xxx : Resistor 5xxx : Coil 7xxx : IC, Transistor, FET
 2xxx : Capacitor 4xxx : SMD jumper 6xxx : Diode 9xxx : Wire jumper

FRONT 1/2

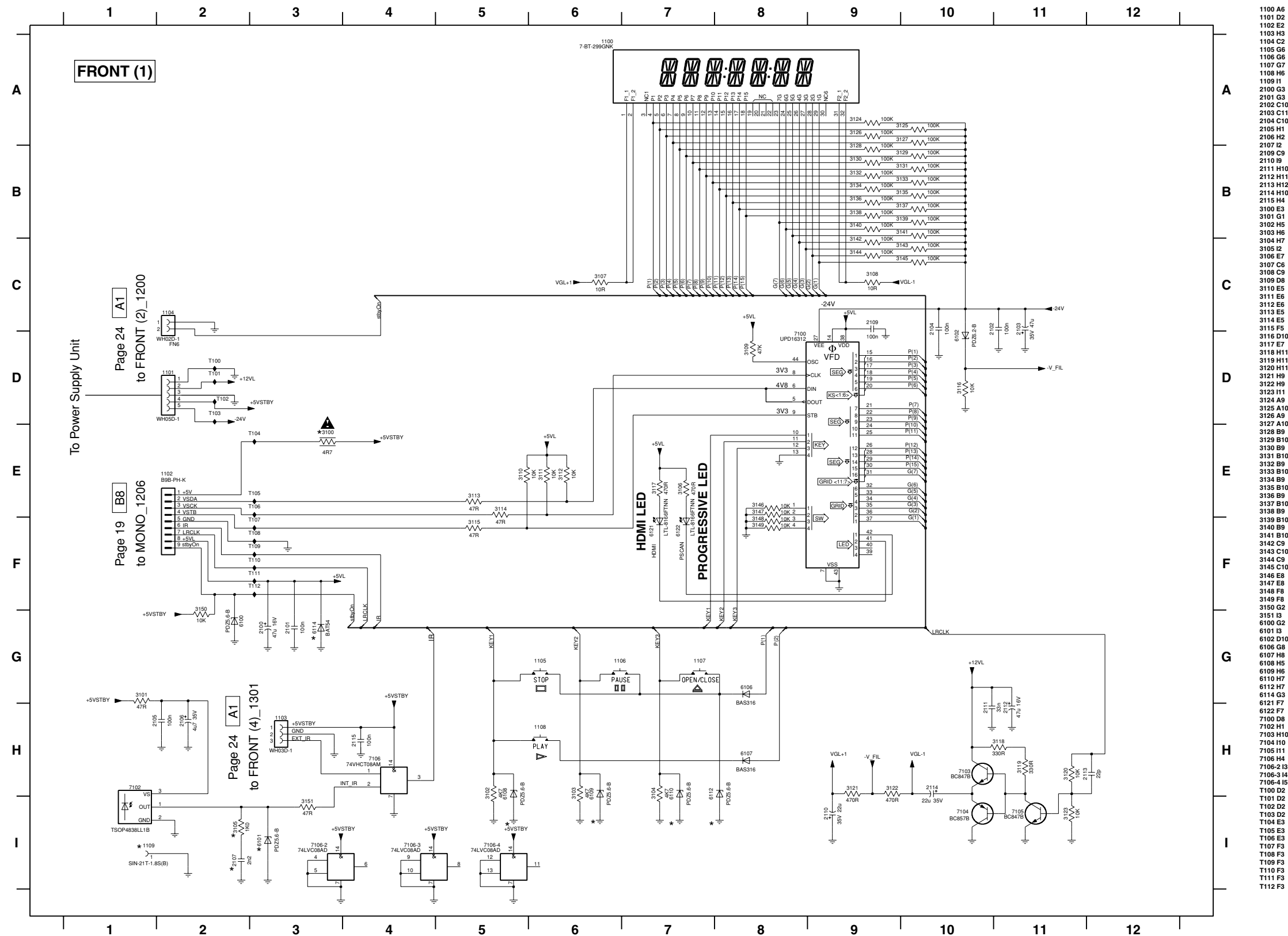

- 1100 A6
- 1101 D2
- 1102 E2
- 1103 H3
- 1104 C2
- 1105 G6
- 1106 G6
- 1107 G7
- 1108 H6
- 1109 H1
- 2100 G3
- 2101 G3
- 2102 C10
- 2103 C11
- 2104 C10
- 2105 H1
- 2106 H2
- 2107 I2
- 2109 C9
- 2110 I9
- 2111 H10
- 2112 H11
- 2113 H12
- 2114 H10
- 2115 H4
- 3100 E3
- 3101 G1
- 3102 H5
- 3103 H6
- 3104 H7
- 3105 I2
- 3106 E7
- 3107 C5
- 3108 C9
- 3109 D8
- 3110 E5
- 3111 E6
- 3112 E6
- 3113 E5
- 3114 E5
- 3115 F5
- 3116 D10
- 3117 E7
- 3118 H11
- 3119 H11
- 3120 H11
- 3121 H9
- 3122 H9
- 3123 H1
- 3124 A8
- 3125 A10
- 3126 A9
- 3127 A10
- 3128 B9
- 3129 B10
- 3130 B9
- 3131 B10
- 3132 B9
- 3133 B10
- 3134 B9
- 3135 B10
- 3136 B9
- 3137 B10
- 3138 B9
- 3139 B10
- 3140 B9
- 3141 B10
- 3142 C9
- 3143 C10
- 3144 C9
- 3145 C10
- 3146 E8
- 3147 E8
- 3148 F8
- 3149 F8
- 3150 G2
- 3151 I3
- 6100 G2
- 6101 I3
- 6102 D10
- 6106 G8
- 6107 H8
- 6108 H5
- 6109 H6
- 6110 H7
- 6112 H7
- 6114 G3
- 6121 F7
- 6122 F7
- 7100 D8
- 7102 H1
- 7103 H10
- 7104 H10
- 7105 H11
- 7106 H4
- 7106-2 I3
- 7106-3 I4
- 7106-4 I5
- T100 D2
- T101 D2
- T102 D2
- T103 D2
- T104 E3
- T105 E3
- T106 E3
- T107 F3
- T108 F3
- T109 F3
- T110 F3
- T111 F3
- T112 F3

★ Components having special characteristics are marked Δ and must be replaced with parts having specifications equal to those originally installed.
 ★ Schematic diagram is subject to change without notice.

FRONT 2/2

The first digit of a component indicates the component type.

- 1xxx : Connector 3xxx : Resistor 5xxx : Coil 7xxx : IC, Transistor, FET
- 2xxx : Capacitor 4xxx : SMD jumper 6xxx : Diode 9xxx : Wire jumper

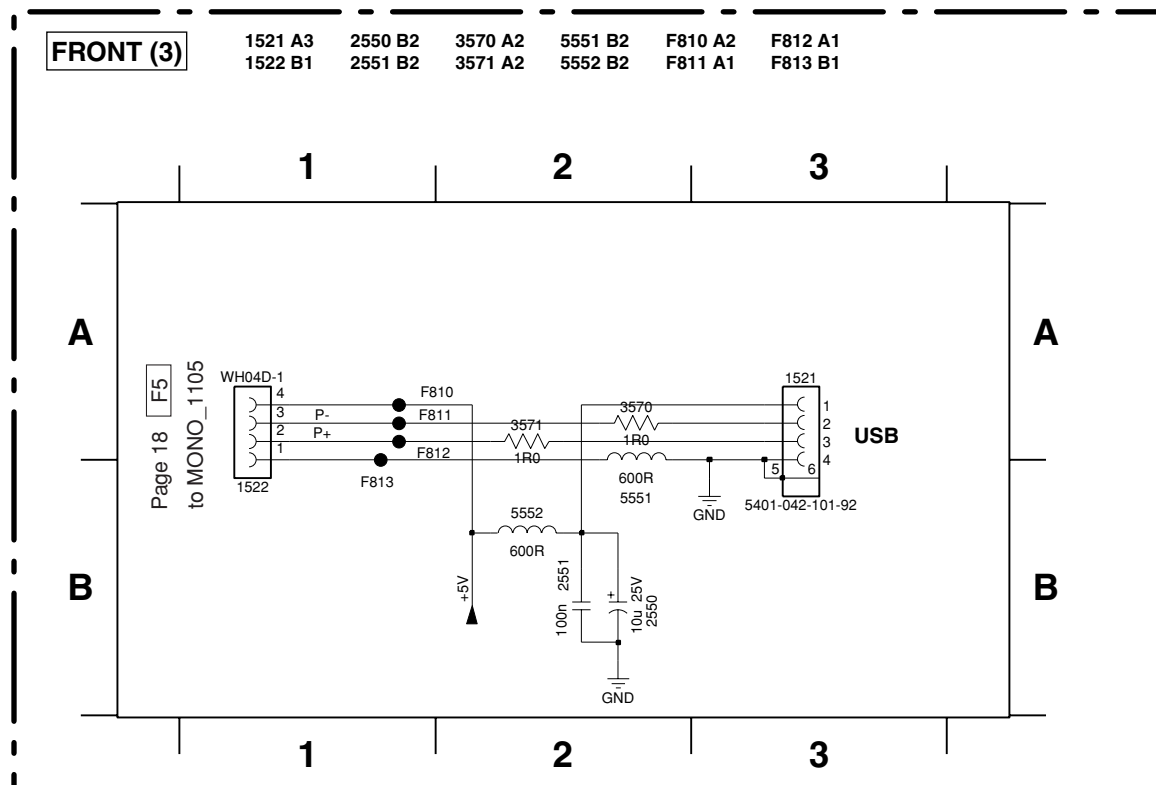
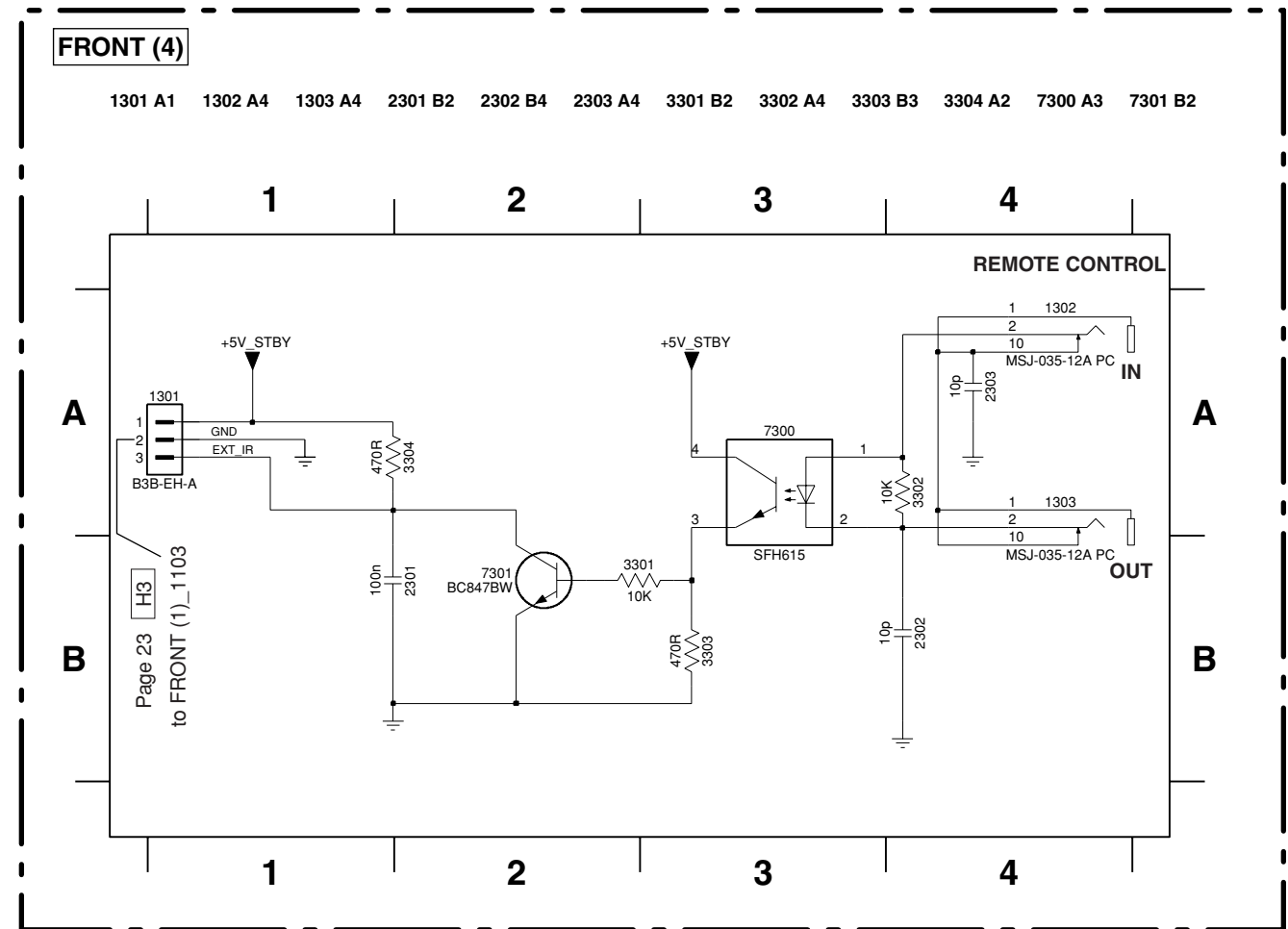
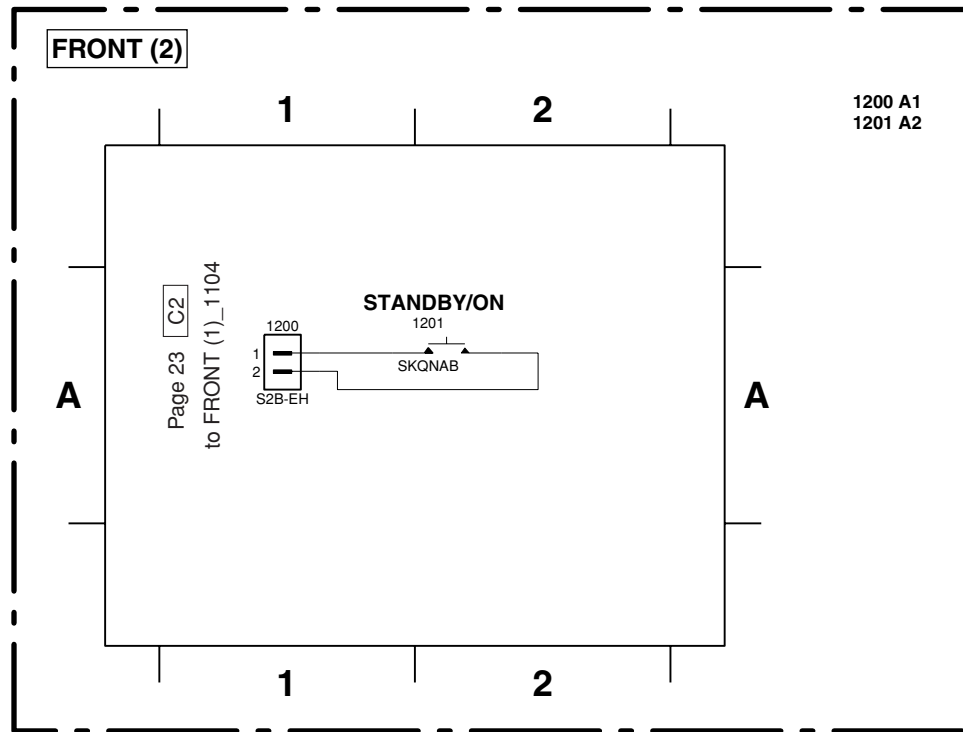

★ Components having special characteristics are marked Δ and must be replaced with parts having specifications equal to those originally installed.
 ★ Schematic diagram is subject to change without notice.

MEMO

MEMO





REPLACEMENT PARTS LIST

When disassembling, use the special screw driver with such tip shape as shown in figure.

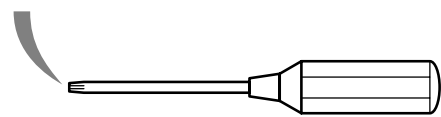
T10  2.7 mm



250 251  3 x 6 S-Tight with the brim

256  3 x 6 S-Tight Black

260  3 x 8 P-Tight Black

 3 x 15 S-Tight Black
(No replacement part available.)

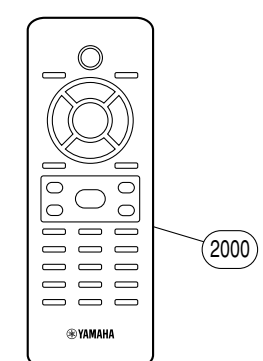
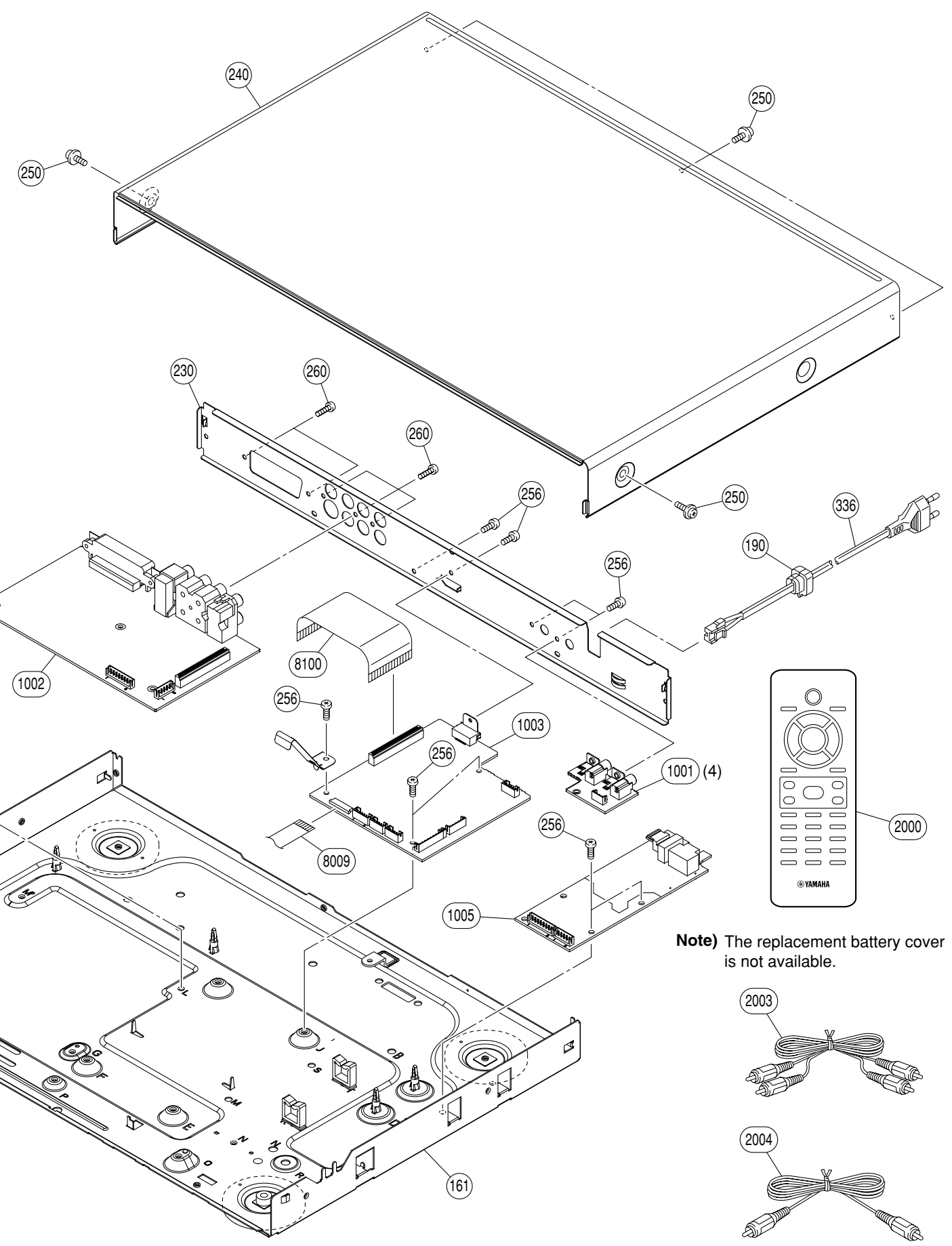

Note) The replacement battery cover is not available.

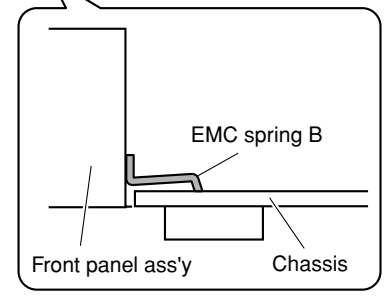
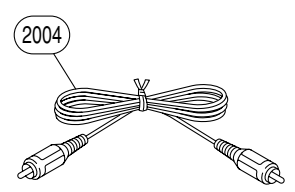
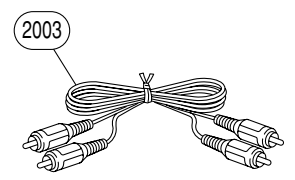

EMC spring B
Front panel ass'y Chassis

1
2
3
4
5
6
7

■ **WARNING**

- Components having special characteristics are marked Δ and must be replaced with parts having specifications equal to those originally installed.

Ref. No.	Part No.	Description	Remarks	Markets
*	101	AAX82190	FRONT PANEL ASS'Y	BL 3141 079 41521
*	101	AAX82200	FRONT PANEL ASS'Y	TI 3141 079 41531
*	101	AAX82210	FRONT PANEL ASS'Y	SI 3141 079 41541
	110	AAX77810	TRAY COVER ASS'Y	3141 079 37091
	161	AAX77820	FRAME ASS'Y	3141 079 37101
	169	AAX77860	BRACKET	3139 244 10241
	190	AAX53540	BUSH	450H259010 3139 114 26671
*	230	AAX82290	REAR PANEL	S661 3139 241 26441
	240	AAX58270	TOP COVER	BL 3139 247 59051
	240	AAX58290	TOP COVER	TI, SI 3139 241 22191
	250	AAX55450	PW HEAD TORX S-TIGHT SCREW	BL 3x6-8 MFZN2B 3139 110 40611
	250	AAX53440	PW HEAD TORX S-TIGHT SCREW	TI, SI 3x6-8 MFN133 3104 120 40081
	251	AAX55450	PW HEAD TORX S-TIGHT SCREW	3x6-8 MFZN2B 3139 110 40611
	256	AAX23640	PAN HEAD TORX S-TIGHT SCREW	3x6 MFZN2B 2511 077 00039
	260	AAX53520	PAN HEAD TORX P-TIGHT SCREW	3x8 MFZN2B 2511 076 50012
	271	AAX69600	EMC SPRING B	3139 241 00042
Δ	336	AAX53630	POWER CABLE	1.8m 2422 070 98231
*	1001	AAX82180	P.C.B. ASS'Y	FRONT 3139 248 51812
*	1002	AAX82360	P.C.B. ASS'Y	AV 3139 248 52351
*	1003	AAX82170	P.C.B. ASS'Y	MONO DVM91USB 3139 248 51821
	1004	AAX79060	DVD MECHANISM UNIT	WXD8829 3139 247 13341
Δ	1005	AAX79050	POWER SUPPLY UNIT	O6P15 3139 247 13351
	8009	AAX53460	FLEXIBLE FLAT CABLE	24P 280mm P=0.5mm 3139 241 00391
	8100	AAX77800	FLEXIBLE FLAT CABLE	30P 60mm P=1.25mm 3139 241 02491
			ACCESSORIES	
*	2000	AAX82300	REMOTE CONTROL	DVD-16 2422 549 01442
	2003	AAX21980	AUDIO PIN CABLE	RD/WH 1.5m 1pc 3103 308 92611
	2004	AAX22970	VIDEO PIN CABLE	YE 1.5m 1pc 3104 108 45432
			BATTERY	AAA, R03, UM-4 2pcs

* New Parts

■ **REMOTE CONTROL DVD-16**

• **PANEL**

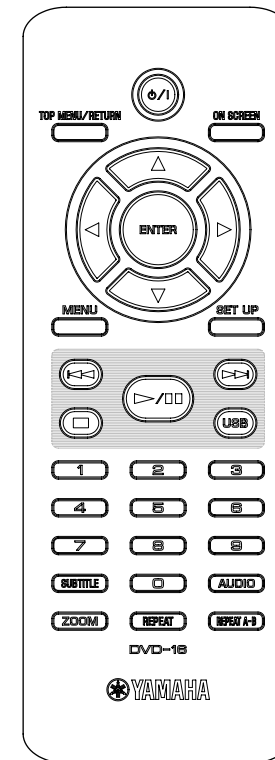

• **KEY NO. LAYOUT**

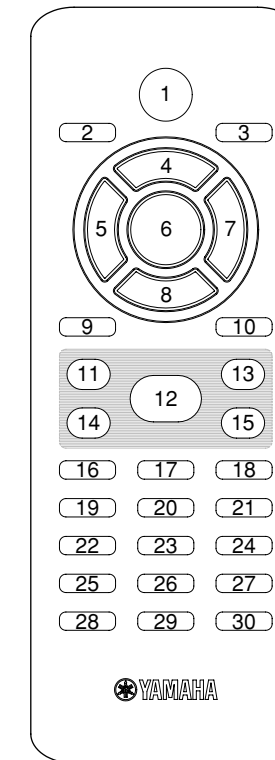

• **KEY CODE**

No.	Key label	Code
1	STANDBY (POWER)	7C-80
2	TOP MENU/RETURN	7C-B1
3	ON SCREEN	7C-A6
4	▲ (UP)	7C-B4
5	◀ (LEFT)	7C-B5
6	ENTER	7C-B8
7	▶ (RIGHT)	7C-B6
8	▼ (DOWN)	7C-B3
9	MENU	7C-B2
10	SET UP	7C-AC
11	◀◀ (SKIP) / SEARCH-	7C-B9
12	▶▶ (PLAY/PAUSE) *	7C-92
13	▶▶ (SKIP) / SEARCH+	7C-BA
14	■ (STOP)	7C-85
15	USB	7C-E6
16	1	7C-94
17	2	7C-95
18	3	7C-96
19	4	7C-97
20	5	7C-98
21	6	7C-99
22	7	7C-9A
23	8	7C-9B
24	9	7C-9C
25	SUBTITLE	7C-AA
26	0	7C-93
27	AUDIO	7C-AD
28	ZOOM	7C-D7
29	REPEAT	7C-A3
30	REPEAT A-B	7C-A4

* Possible receiving
PLAY : 7C-82
PAUSE : 7C-83

■ SCENE CONTROL

• Example of connection

RECEIVER/AMPLIFIER
(Model with SCENE function)

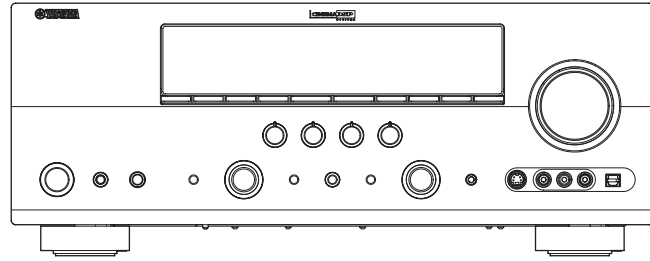

DVD/CD PLAYER
(Model with SCENE control signal reception function)

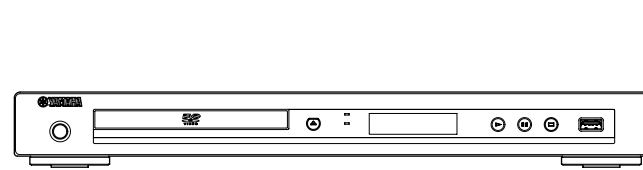

REMOTE CONTROL OUT → REMOTE CONTROL IN
Monaural analog mini cable

• SCENE control

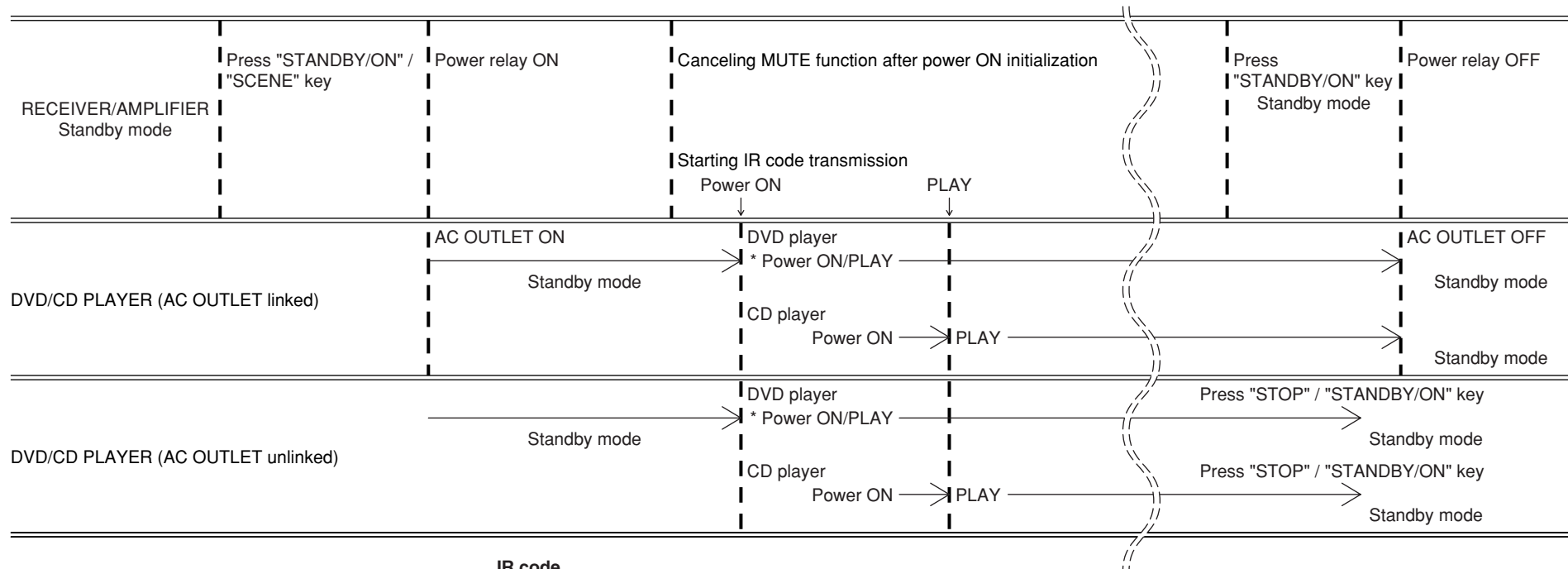

IR code

	Power ON	PLAY
DVD	* 7C-82 [PLAY code]	-
CD	79-7E	79-02

* When the DVD player receives the IR code [PLAY], the power is turned on and the disc is played at the same time.