

DVD AUDIO/VIDEO SA-CD PLAYER

DVD-S657/DV-S5860

SERVICE MANUAL

IMPORTANT NOTICE

This manual has been provided for the use of authorized YAMAHA Retailers and their service personnel.

It has been assumed that basic service procedures inherent to the industry, and more specifically YAMAHA Products, are already known and understood by the users, and have therefore not been restated.

WARNING: Failure to follow appropriate service and safety procedures when servicing this product may result in personal injury, destruction of expensive components, and failure of the product to perform as specified. For these reasons, we advise all YAMAHA product owners that any service required should be performed by an authorized YAMAHA Retailer or the appointed service representative.

IMPORTANT: The presentation or sale of this manual to any individual or firm does not constitute authorization, certification or recognition of any applicable technical capabilities, or establish a principle-agent relationship of any form.

The data provided is believed to be accurate and applicable to the unit(s) indicated on the cover. The research, engineering, and service departments of YAMAHA are continually striving to improve YAMAHA products. Modifications are, therefore, inevitable and specifications are subject to change without notice or obligation to retrofit. Should any discrepancy appear to exist, please contact the distributor's Service Division.

WARNING: Static discharges can destroy expensive components. Discharge any static electricity your body may have accumulated by grounding yourself to the ground buss in the unit (heavy gauge black wires connect to this buss).

IMPORTANT: Turn the unit OFF during disassembly and part replacement. Recheck all work before you apply power to the unit.

CONTENTS

TO SERVICE PERSONNEL	2~3	DISASSEMBLY PROCEDURES / 分解手順	11~12
PREVENTION OF ELECTROSTATIC DISCHARGE	4	MAINTENANCE FLOW CHART /	
LOCALE MANAGEMENT INFORMATION	4	メンテナンスフローチャート	13~22
FRONT PANELS	5	BLOCK DIAGRAM	23
REAR PANELS	5~6	WIRING DIAGRAM	24
REMOTE CONTROL	6	PRINTED CIRCUIT BOARD	25~30
SPECIFICATIONS / 参考仕様	7~8	SCHEMATIC DIAGRAM	31~37
INTERNAL VIEW	9	EXPLODED VIEW	38
REPAIR NOTES / 修理上の留意点	10	MECHANICAL PARTS	39



このサービスマニュアルは、エコマーク認定の再生紙を使用しています。
This Service Manual uses recycled paper.

© 2005 YAMAHA CORPORATION All rights reserved.

100950



YAMAHA CORPORATION
P.O.Box 1, Hamamatsu, Japan
'05.05

DVD-S657/DV-S5860

■ TO SERVICE PERSONNEL

1. Critical Components Information
Components having special characteristics are marked \triangle and must be replaced with parts having specifications equal to those originally installed.
 2. Leakage Current Measurement (For 120V Models Only)
When service has been completed, it is imperative to verify that all exposed conductive surfaces are properly insulated from supply circuits.
- Meter impedance should be equivalent to 1500 ohms shunted by 0.15 μ F.

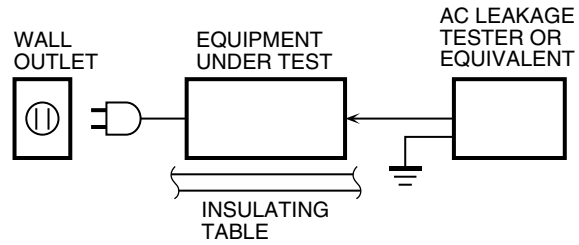

- Leakage current must not exceed 0.5mA.
- Be sure to test for leakage with the AC plug in both polarities.

WARNING: CHEMICAL CONTENT NOTICE!

The solder used in the production of this product contains LEAD. In addition, other electrical/electronic and/or plastic (where applicable) components may also contain traces of chemicals found by the California Health and Welfare Agency (and possibly other entities) to cause cancer and/or birth defects or other reproductive harm.

DO NOT PLACE SOLDER, ELECTRICAL/ELECTRONIC OR PLASTIC COMPONENTS IN YOUR MOUTH FOR ANY REASON WHATSOEVER!

Avoid prolonged, unprotected contact between solder and your skin! When soldering, do not inhale solder fumes or expose eyes to solder/flux vapor!

If you come in contact with solder or components located inside the enclosure of this product, wash your hands before handling food.

WARNING: Laser Safety

This product contains a laser beam component. This component may emit invisible, as well as visible radiation, which may cause eye damage. To protect your eyes and skin from laser radiation, the following precautions must be used during servicing of the unit.

- 1) When testing and/or repairing any component within the product, keep your eyes and skin more than 30 cm away from the laser pick-up unit at all times. Do not stare at the laser beam at any time.
- 2) Do not attempt to readjust, disassemble or repair the laser pick-up, unless noted elsewhere in this manual.
- 3) CAUTION : Use of controls, adjustments or performance of procedures other than those specified herein may result in hazardous radiation exposure.

Laser Emitting conditions:

- 1) When the Top Cover is removed, and the STANDBY/ON SW is turned to the "ON" position, the laser component will emit a beam for several seconds to detect if a disc is present. During this time (5-10 sec.) the laser may radiate through the lens of the laser pick-up unit. Do not attempt any servicing during this period!
If no disc is detected, the laser will stop emitting the beam. When a disc is loaded, you will not be exposed to any laser emissions.
- 2) The laser power level can be adjusted with the VR on the pick-up PWB, however, this level has been set by the factory prior to shipping from the factory. Do not adjust this laser level control unless instruction is provided elsewhere in this manual. Adjustment of this control can increase the laser emission level from the device.

警告：レーザーの安全対策

本機はレーザー光線を放射する部品を搭載しています。この部品が放射するレーザー光線は目に損傷を起こします。このレーザー光線から目及び肌を保護するために、本機の修理作業中は下記の注意を厳守してください。

- 1) テスト時または修理時、目及び肌を光ピックアップから30cm以上離してください。いかなる場合もレーザー光線を見つめないでください。
- 2) 光ピックアップの再調整及び分解はしないでください。
- 3) このマニュアル上で指定されている以外の制御、調整、手順はレーザー光線を照射される結果を招く恐れがあります。

レーザー放射条件

- 1) トップカバーを取り外しSTANDBY/ONスイッチをONにすると、ディスク検知のため5～10秒間、光ピックアップからレーザー光線が放射されます。この間、修理はしないでください。
ディスクが検知されなければ、レーザー光線の放射は停止します。ディスクがセットされている場合、ディスクで遮られるのでレーザー光線は修理担当者には届きません。
- 2) レーザーパワーレベルは光ピックアップ基板上のVRにより調整可能ですが、工場出荷前に調整セット済みなので、このVRは廻さないでください。このVRを廻すと装置からのレーザー光線の放射レベルが上がる恐れがあります。

Laser Diode Properties

Type: Semiconductor laser GaAlAs
 Wave length: 650 nm (DVD)
 780 nm (VCD/CD)
 Output Power: 7 mW (DVD), 10 mW (VCD/CD)
 Beam divergence 60 degree

レーザー

タイプ 半導体レーザー-GaAlAs
 波長 650 nm (DVD)
 780 nm (VCD/CD)
 出力 7 mW (DVD), 10 mW (VCD/CD)
 ビーム広がり 60度

VARO! : AVATTAESSA JA SUOJALUKITUS OHITETTAESSA OLET ALTTIINA NÄKYMÄTTÖMÄLLE LASER-SÄTEILYLLE. ÄLÄ KATSO SÄTEESEEN.

WARNING! : OSYNLIG LASERSTRÅLNING NÄR DENNA DEL ÄR ÖPPNAD OCH SPÄRREN ÄR URKOPPLAD. BETRAKTA EJ STRÅLEN.

WARNING

The use of optical instruments with this product will increase eye hazard.

Repair handling should take place as much as possible with a disc loaded inside the player.

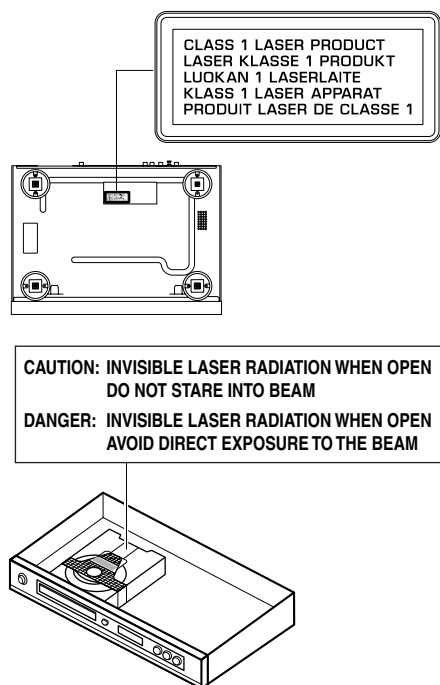

CAUTION VISIBLE AND INVISIBLE LASER RADIATION WHEN OPEN. AVOID EXPOSURE TO BEAM.

ADVARSEL SYNLIG OG USYNLIG LASERSTRÅLING VED ÅBNING. UNDGÅ UDSÆTTELSE FOR STRÅLING.

ADVARSEL SYNLIG OG USYNLIG LASERSTRÅLING NÄR DEKSEL ÅPNES. UNNGÅ EKSPONERING FOR STRÅLEN.

VARNING SYNLIG OCH OSYNLIG LASERSTRÅLNING NÄR DENNA DEL ÄR ÖPPNAD. BETRAKTA EJ STRÅLEN.

VARO! AVATTAESSA OLET ALTTIINA NÄKYVÄLLE JA NÄKYMÄTTÖMÄLLE LASER SÄ TEILYLLE. ÄLÄ KATSO SÄTEESEEN.

VORSICHT SICHTBARE UND UNSICHTBARE LASERSTRAHLUNG WENN ABDECKUNG GEÖFFNET. NICHT DEM STRAHL AUSSETZEN.

DANGER VISIBLE AND INVISIBLE LASER RADIATION WHEN OPEN. AVOID DIRECT EXPOSURE TO BEAM.

ATTENTION RAYONNEMENT LASER VISIBLE ET INVISIBLE EN CAS D'OUVERTURE. EXPOSITION DANGEREUSE AU FAISCEAU

Warning for power supply

The primary side of the power supply carries live mains voltage when the player is connected to the mains even when the player is switched off !

This primary area is not shielded so it is possible to touch copper tracks and/or components when servicing the player. Service personnel have to take precautions to prevent touching this area or components in this area.

Note:

The screws on the DVD mechanism may never be touched, removed or re-adjusted.

Handle the DVD mechanism with care when the unit has to be exchanged!

The DVD mechanism is very sensitive for dropping or giving shocks.

■ PREVENTION OF ELECTROSTATIC DISCHARGE

The laser diode in the DVD mechanism may be damaged due to static electricity from clothes or the human body. Use caution to prevent electrostatic damage when servicing or handling the DVD-mechanism.

1. Grounding for electrostatic damage prevention

Some devices, such as the DVD player, use an optical pickup (laser diode) that will be damaged by static electricity in the working environment. Only attempt service after ensuring that all grounding procedures have been completed.

1. Worktable grounding

Put a grounded conductive material (sheet) or iron sheet on the area where the optical pickup is placed.

2. Human body grounding

Use an anti-static wrist strap to discharge the static electricity from your body.

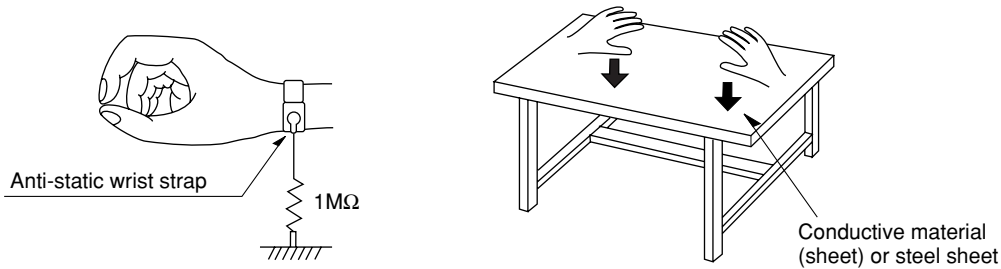

2. Handling Precautions for DVD mechanism

1. Handle the DVD mechanism gently, as it is an extremely high-precision assembly.
2. The flexible cable lines may break if an excessive force is applied to it. Use caution when handling the cable.
3. The semi-fixed resistor for laser power adjustment should not be adjusted. Do not turn the resistor.

■ LOCALE MANAGEMENT INFORMATION

Locale Management Information : This DVD player is designed and manufactured to respond to the Locale Management Information that is recorded on a DVD disc. If the Locale number described on the DVD disc does not correspond to the Locale number of this DVD player, this DVD player cannot play this disc.

This product incorporates copyright protection technology that is protected by method claims of certain U.S. patents and other intellectual property rights owned by Macrovision Corporation and other rights owners. Use of this copyright protection technology must be authorized by Macrovision Corporation, and is intended for home and other limited viewing uses only unless otherwise authorized by Macrovision Corporation. Reverse engineering or disassembly is prohibited.

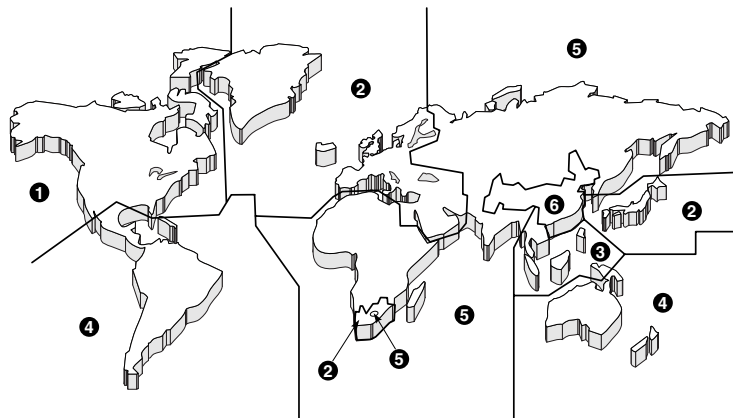

FRONT PANELS

DVD-S657 (U, R, K, A, B, G, P, J models)

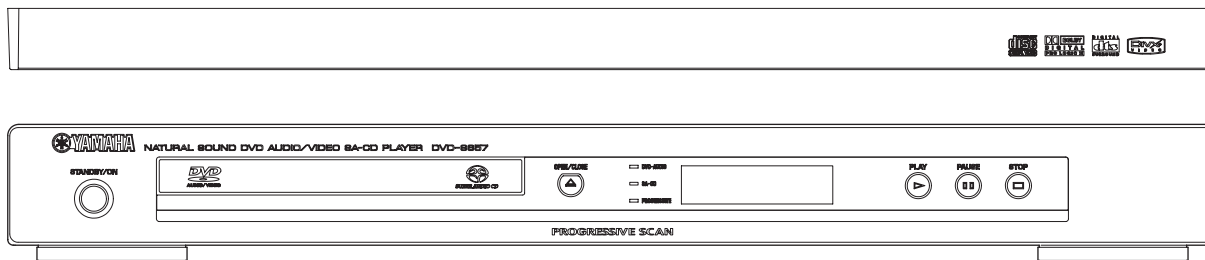

DV-S5860 (U, A models)

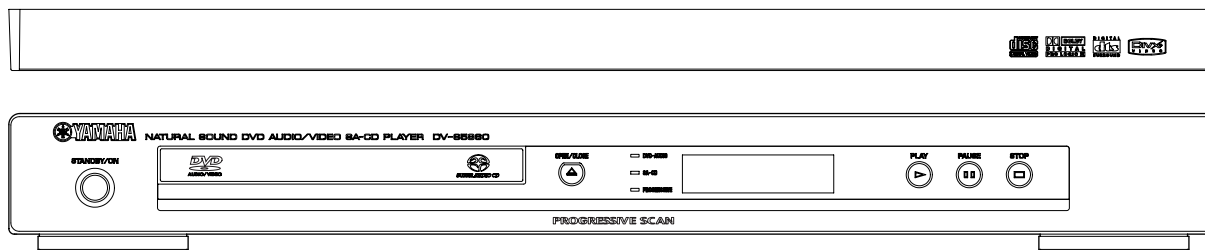

REAR PANELS

DVD-S657 (U model)

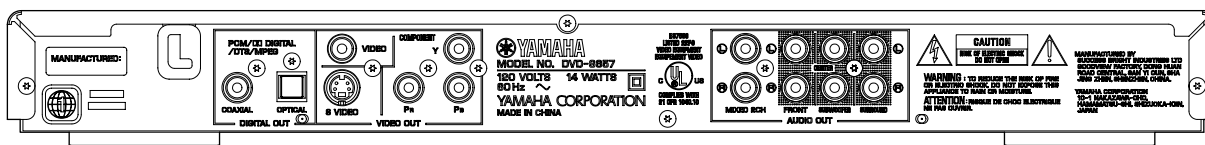

DVD-S657 (R model)

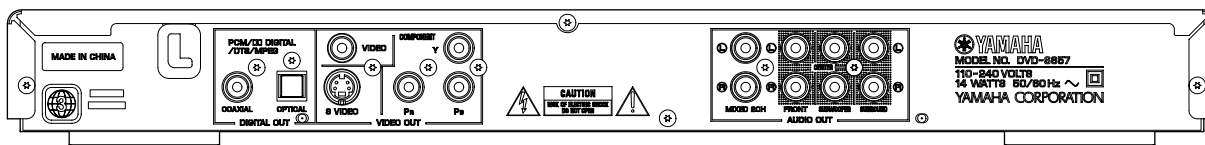

DVD-S657 (K model)

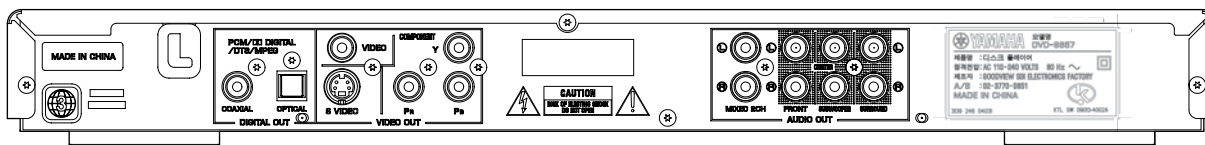

DVD-S657 (A model)

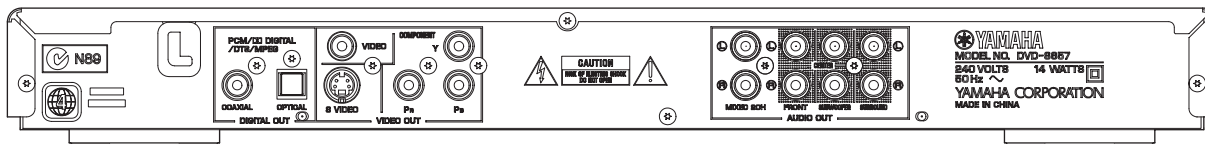

DVD-S657 (B, G models)

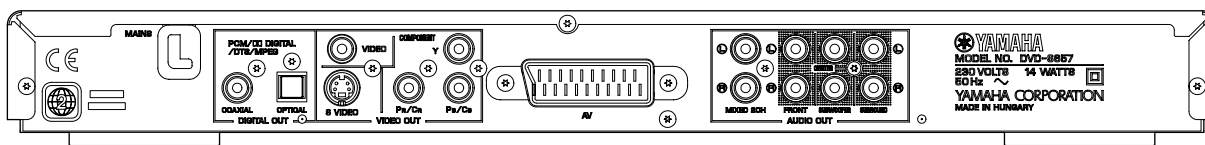

DVD-S657 (P model)

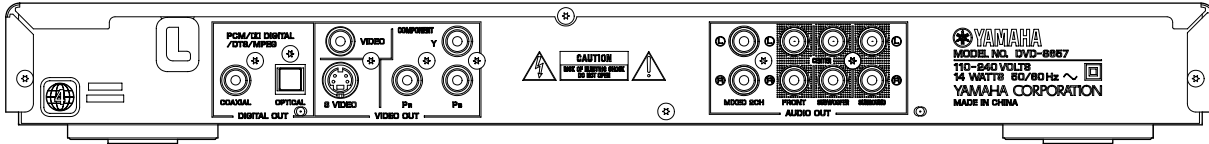

DVD-S657 (J model)

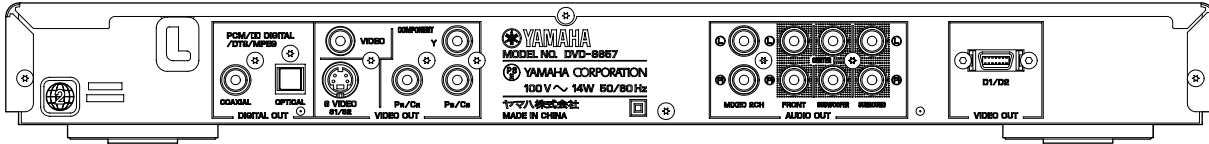

DV-S5860 (U model)

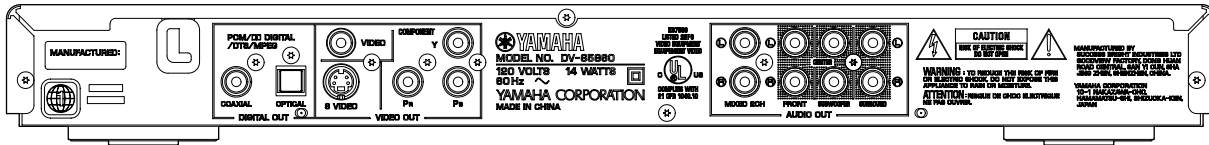

DV-S5860 (A model)

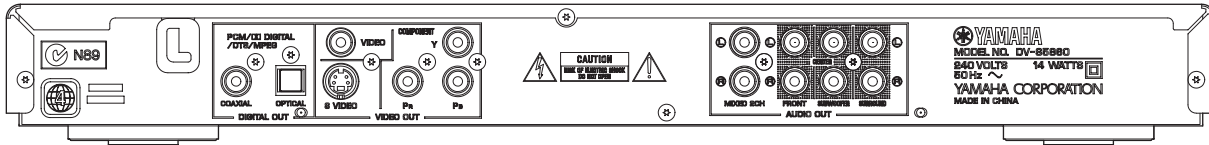

■ REMOTE CONTROL

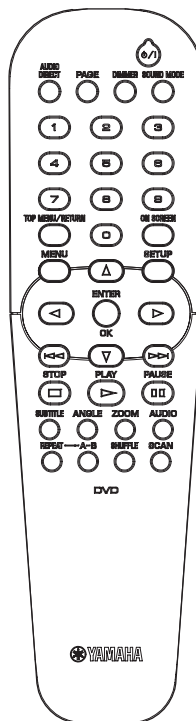

■ SPECIFICATIONS / 参考仕様

PLAYBACK SYSTEM / 対応ディスク

DVD Video
 DVD-Audio
 SA-CD multi-channel and SA-CD stereo
 Video CD & SVCD
 CD
 PICTURE CD
 CD-R, CD-RW
 DVD+R, DVD+RW
 DVD-R, DVD-RW

VIDEO PERFORMANCE / ビデオ部

Video (CVBS) Output 1 Vpp into 75 ohms
 S-Video Output Y: 1Vpp into 75 ohms
 C: 0.3Vpp into 75 ohms
 Component Video Output Y: 1Vpp into 75 ohms
 Pb/Cb Pr/Cr: 0.7Vpp into 75 ohms
 RGB (SCART) Output 0.7 Vpp into 75 ohms (B, G models)
 D1/D2 Y:1 Vpp into 75 ohms (J model)
 Pb/Cb Pr/Cr: 0.7Vpp into 75 ohms
 (J model)

AUDIO FORMAT / オーディオフォーマット

Digital Mpeg/Dolby Digital/Compressed Digital
 DTS
 PCM 16, 20, 24 bits
 fs, 44.1, 48, 96 kHz
 MP3(ISO 9660) 24, 32, 56, 64, 96, 128, 256 kbps
 fs 16, 22.05, 24, 32, 44.1, 48 kHz
 WMA 32 kbps~192 kbps, mono, stereo
 Full decoding of Dolby Digital, DTS and MPEG multi-channel
 sound/analog stereo sound
 Dolby Surround Compatible Downmix from Dolby Digital
 multi-channel sound
 3D sound for virtual 5.1 channel sound on two speakers
 Dolby Pro Logic II 5.1 ch decoding from the stereo source

AUDIO PERFORMANCE / オーディオ特性

DA Converter 24 bits
 Signal-Noise (1kHz) 110 dB
 Dynamic Range (1kHz) 100 dB
 DVD fs 96 kHz 2 Hz to 44 kHz
 fs 48 kHz 2 Hz to 22 kHz
 SVCD fs 48 kHz 2 Hz to 22 kHz
 fs 44.1 kHz 2 Hz to 20 kHz
 CD/VCD fs 44.1 kHz 2 Hz to 20 kHz
 Distortion and Noise (1kHz) 0.003%

TV STANDARD (PAL/50Hz) (NTSC/60Hz)

Number of lines 625 525
 Playback Multistandard (PAL/NTSC)

CONNECTIONS / 接続端子

SCART Euroconnector (B, G models)
 D Terminal (J model)
 Y Output Cinch (green)
 Pb/Cb Output Cinch (blue)
 Pr/Cr Output Cinch (red)
 S-Video Output Mini DIN, 4 pins
 Video Output Cinch (yellow)
 Audio Output (L+R) Cinch (white / red)
 Digital Output 1 coaxial, 1 optical
 IEC60958 for CDDA / LPCM / MPEG1
 IEC61937 for MPEG 2, Dolby Digital
 and DTS

6 channel analog output

Audio Front L/R Cinch (white / red)
 Audio Surround L/R Cinch (white / red)
 Audio Center Cinch (blue)
 Audio Subwoofer Cinch (black)

GENERAL / 一般

Dimensions (W x H x D) / 435 x 51 x 318 mm
 寸法 (幅 x 高さ x 奥行き) (17-1/8" x 2" x 12-1/2")
 Weight / 質量 Approx. 2.6 Kg (5 lbs. 12 oz)
 Finish / 仕上げ [DVD-S657] Gold Color (R, K, J models)
 Black Color (U, A, G, P models)
 Titanium Color (U, B, G models)
 Silver Color (R, G, J models)
 [DV-S5860] Black Color (U model)
 Silver Color (U, A models)
 Power Supply / 電源電圧 AC120V, 60 Hz (U model)
 AC240V, 50 Hz (A model)
 AC110~240V, 50/60 Hz (R, K, P models)
 AC230V, 50 Hz (B, G models)
 AC100V, 50/60 Hz (J model)
 Power Consumption / 消費電力 Approx. 14W
 Standby Power Consumption / < 1W
 待機時消費電力

ACCESSORIES

Remote Control x 1, Battery x 2
 Audio/Video Cable (U, R, K, A, P, J models)
 Audio Pin Cable (B, G models)
 Video Pin Cable (B, G models)

**Specifications subject to change without prior notice.*

U U.S.A and Canada models R General model
 K Korean model A Australian model
 B British model G European model
 P South American model J Japanese model

DOLBY DIGITAL PRO LOGIC II

Manufactured under license from Dolby Laboratories.
 "Dolby", "Pro Logic" and the double-D symbol are trademarks of Dolby Laboratories.
 ドルビーラボラトリーズからの実施権により製造されています。「ドルビー」、「PRO LOGIC」及びダブルD記号は、ドルビーラボラトリーズの商標です。

DIGITAL dts SURROUND

"DTS" and "DTS Digital Surround" are registered trademarks of Digital Theater Systems, Inc.
 DTS および DTS Digital Surround はデジタルシアターシステムズの登録商標です。

DIVX VIDEO
HOME THEATER DIVX CERTIFIED VIDEO

DivX, DivX Certified, and associated logos are trademarks of DivXNetworks, Inc and are used under license.
 DivX はDivXネットワークスおよびその実施権の登録商標です。

This product incorporates copyright protection technology that is protected by method claims of certain U.S. patents and other intellectual property rights owned by Macrovision Corporation and other rights owners. Use of this copyright protection technology must be authorized by Macrovision Corporation, and is intended for home and other limited viewing uses only unless otherwise authorized by Macrovision Corporation. Reverse engineering or disassembly is prohibited.

• DIMENSIONS / 寸法図

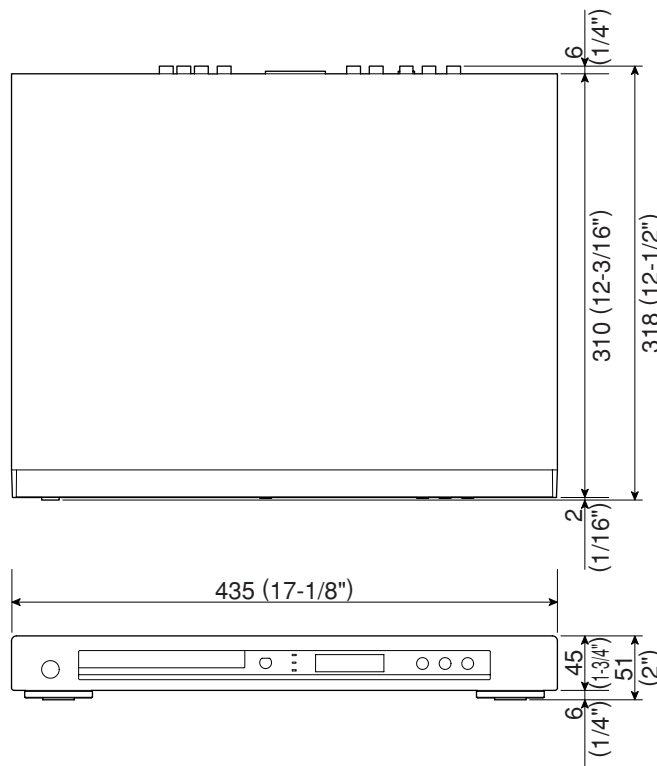

INTERNAL VIEW

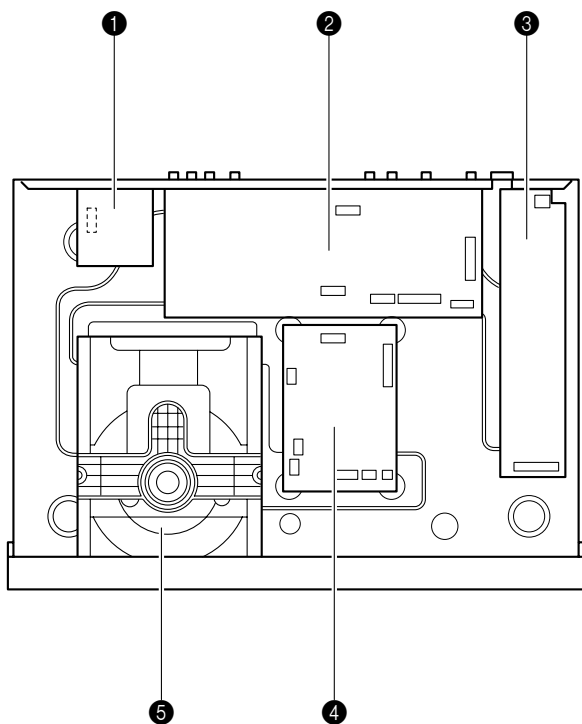

- ① HDMI D2 Board (J model)
- ② AV Board
- ③ Power Supply Unit
- ④ MONO Board
- ⑤ DVD Mechanism

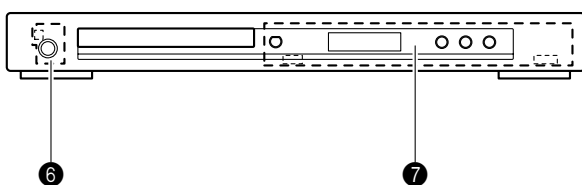

- ⑥ Front (2) Standby Board
- ⑦ Front (1) Display Board

REPAIR NOTES / 修理上の留意点

● Repair Tips

None of the components of the following units can be supplied separately.

Each unit must be replaced as a whole in case of a failure.

- DVD Mechanism
- MONO Board
- FRONT Board
- AV Board
- Power Supply Unit

● Power Supply Unit

Never touch the potentiometer (VR301) installed to the Power Supply Unit.

● 修理について

下記のユニットは、小部品の部品供給はできません。故障の場合は、各ユニットを交換してください。

- DVDメカ
- MONO Board
- FRONT Board
- AV Board
- HDMI D2 Board
- 電源ユニット

● 電源ユニットについて

電源ユニットに搭載されている可変抵抗 (VR301) は、絶対に触らないでください。

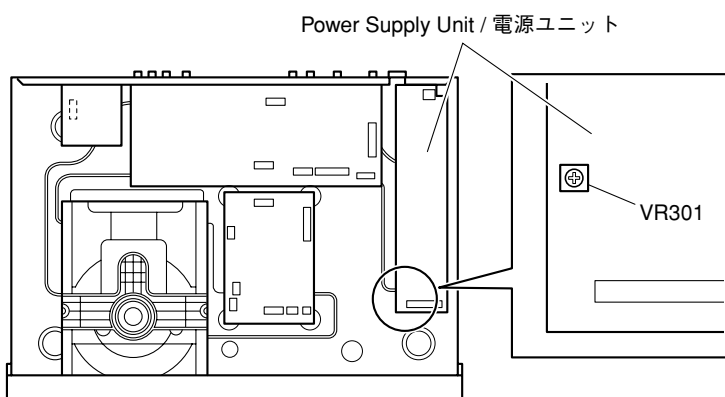

DISASSEMBLY PROCEDURES

See EXPLODED VIEW for item numbers.

When disassembling, use the special screw driver with tip shape in figure.

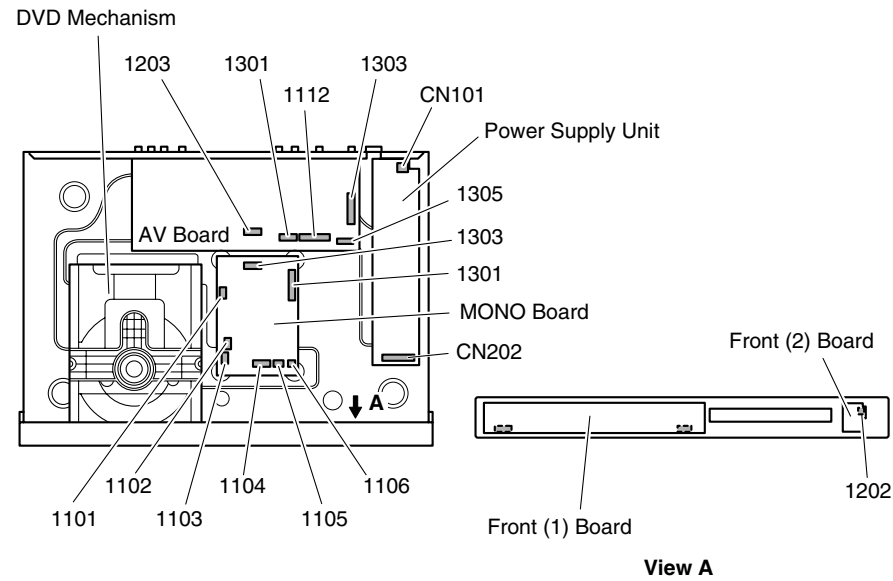
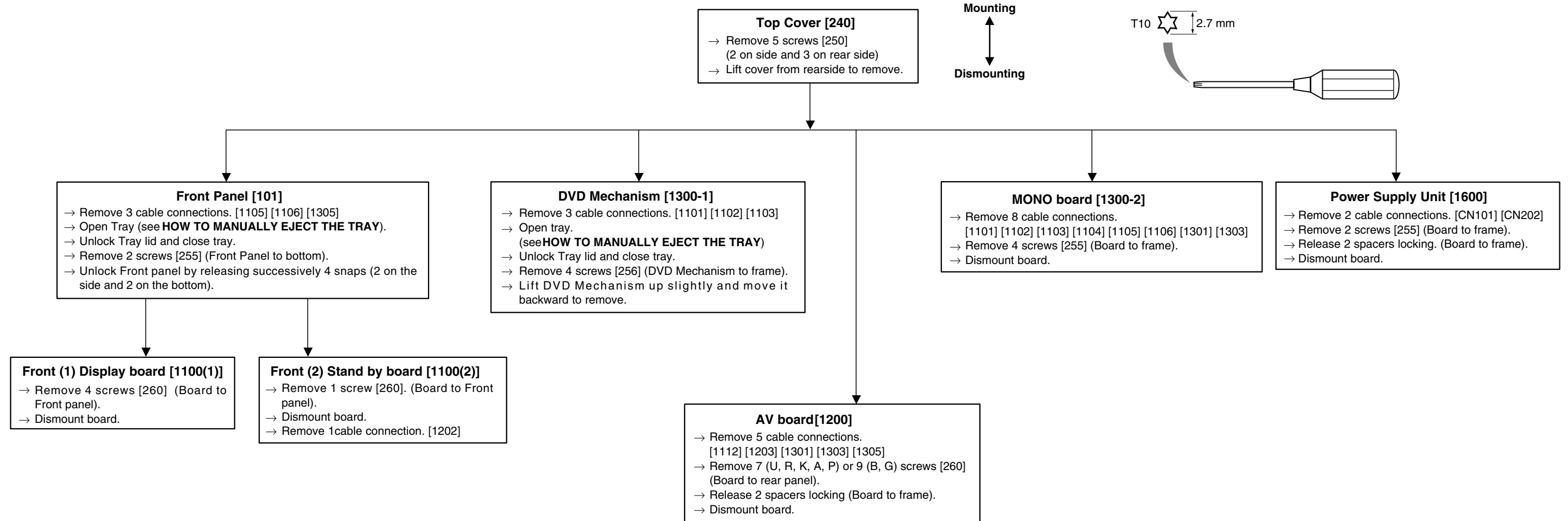

HOW TO MANUALLY EJECT THE TRAY

- Turn the player bottom up.
- Move the slider in the direction indicated with a screw driver until the tray is ejected.
- Gently pull the tray out.

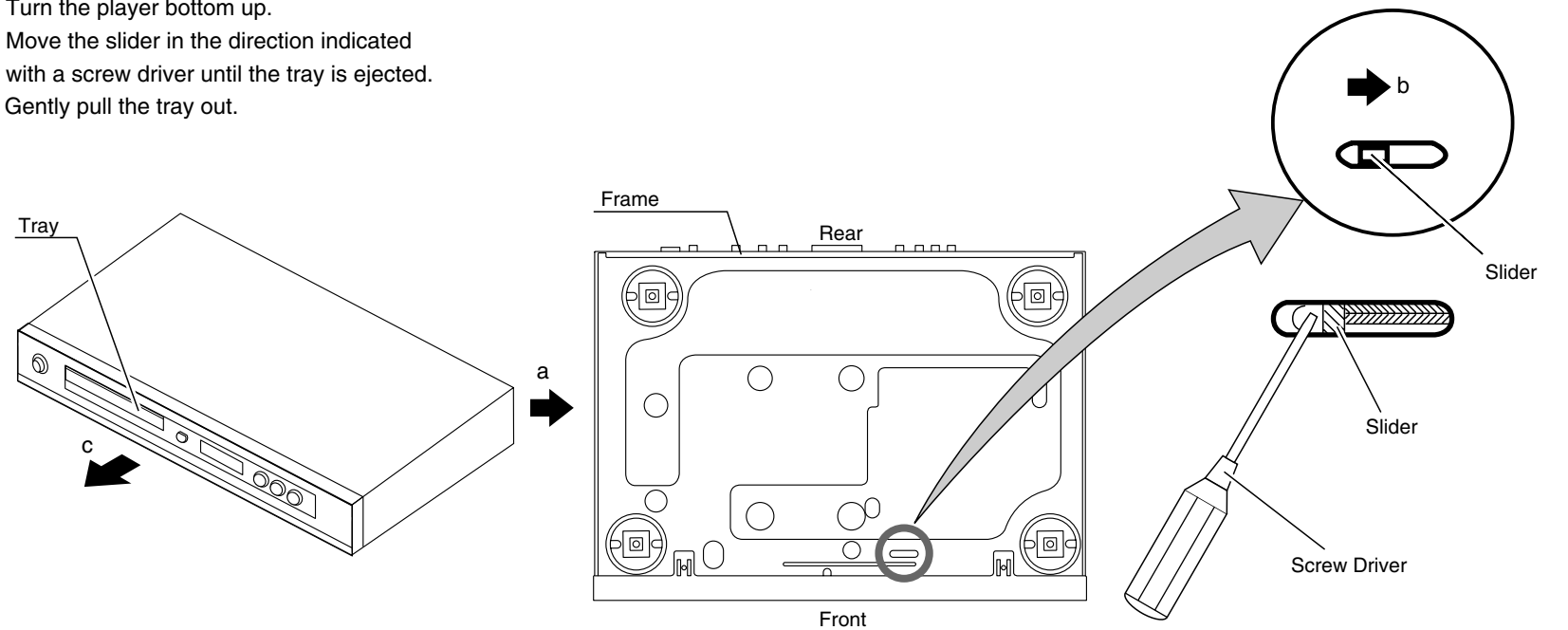

■ 分解手順

項目番号については分解図を参照してください。

分解には図のような特殊ドライバーを使用します。

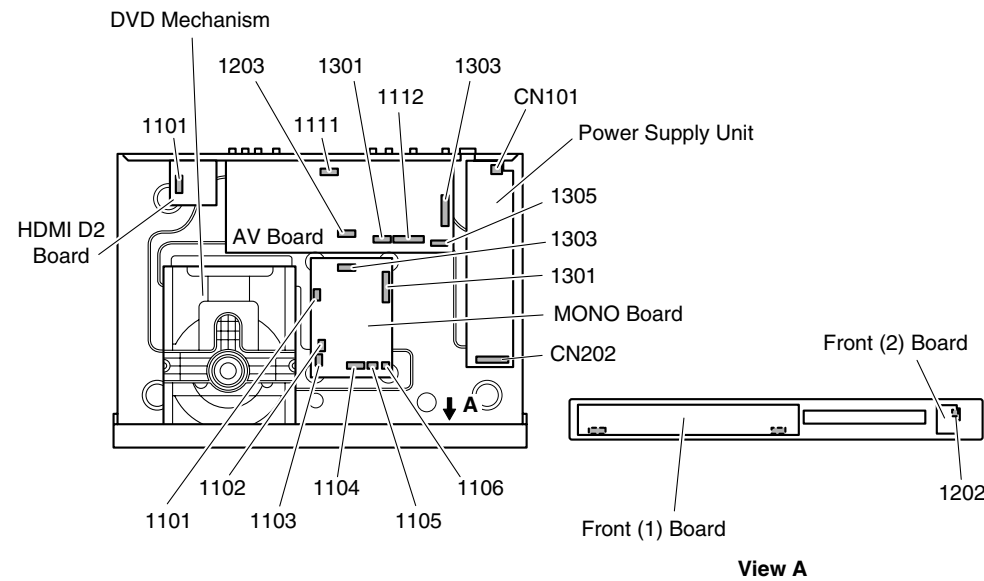
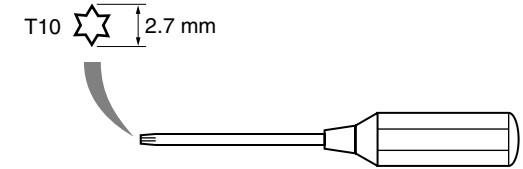
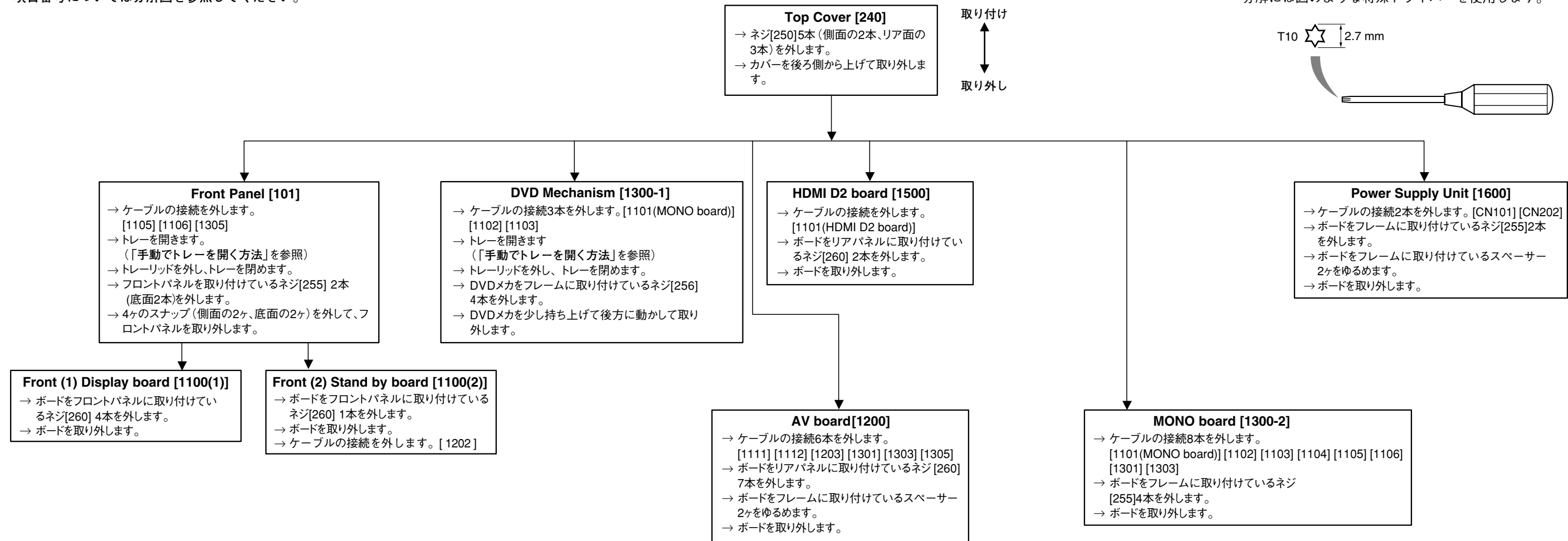

● 手動でトレイを開く方法

- 本体を上下反転します。
- トレイが出てくるまで、ドライバーでスライダーを図に示す矢印の方向に動かします。
- トレイをそっと引き出します。

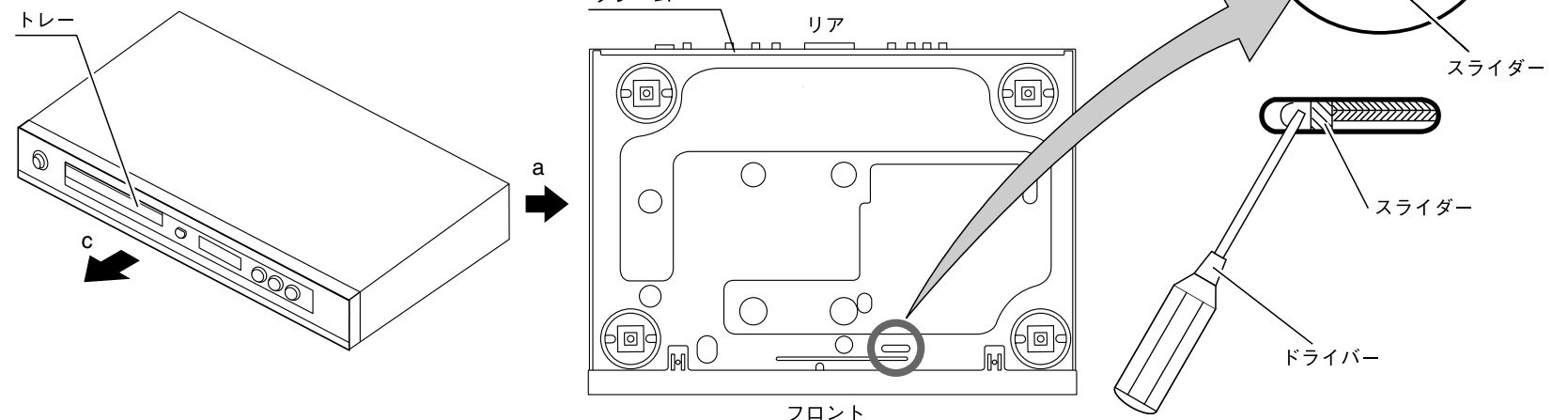

MAINTENANCE FLOW CHART

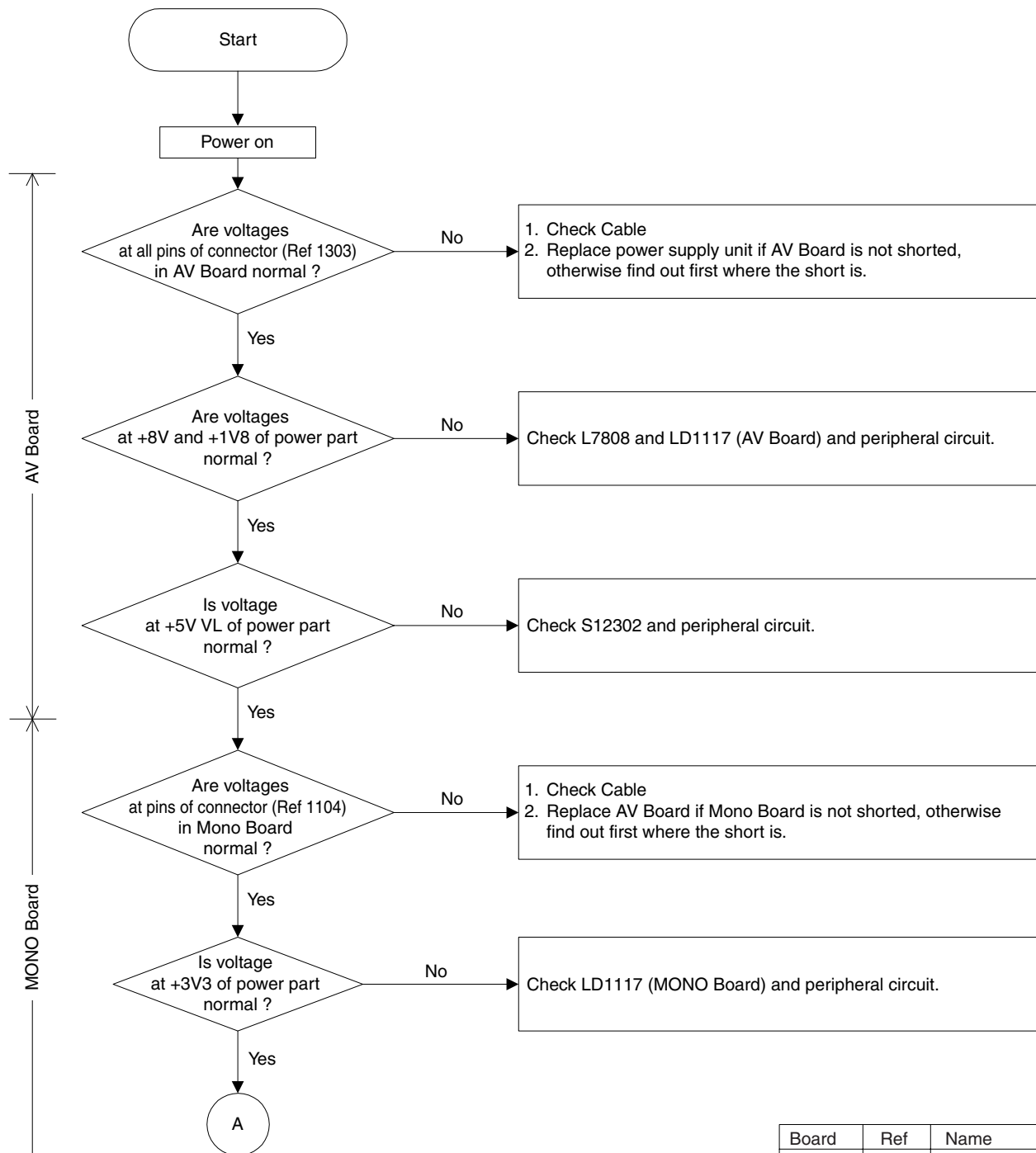

Board	Ref	Name
MONO	7101	LD1117
AV	7301	L7808
AV	7303	LD1117
AV	7306	S12302

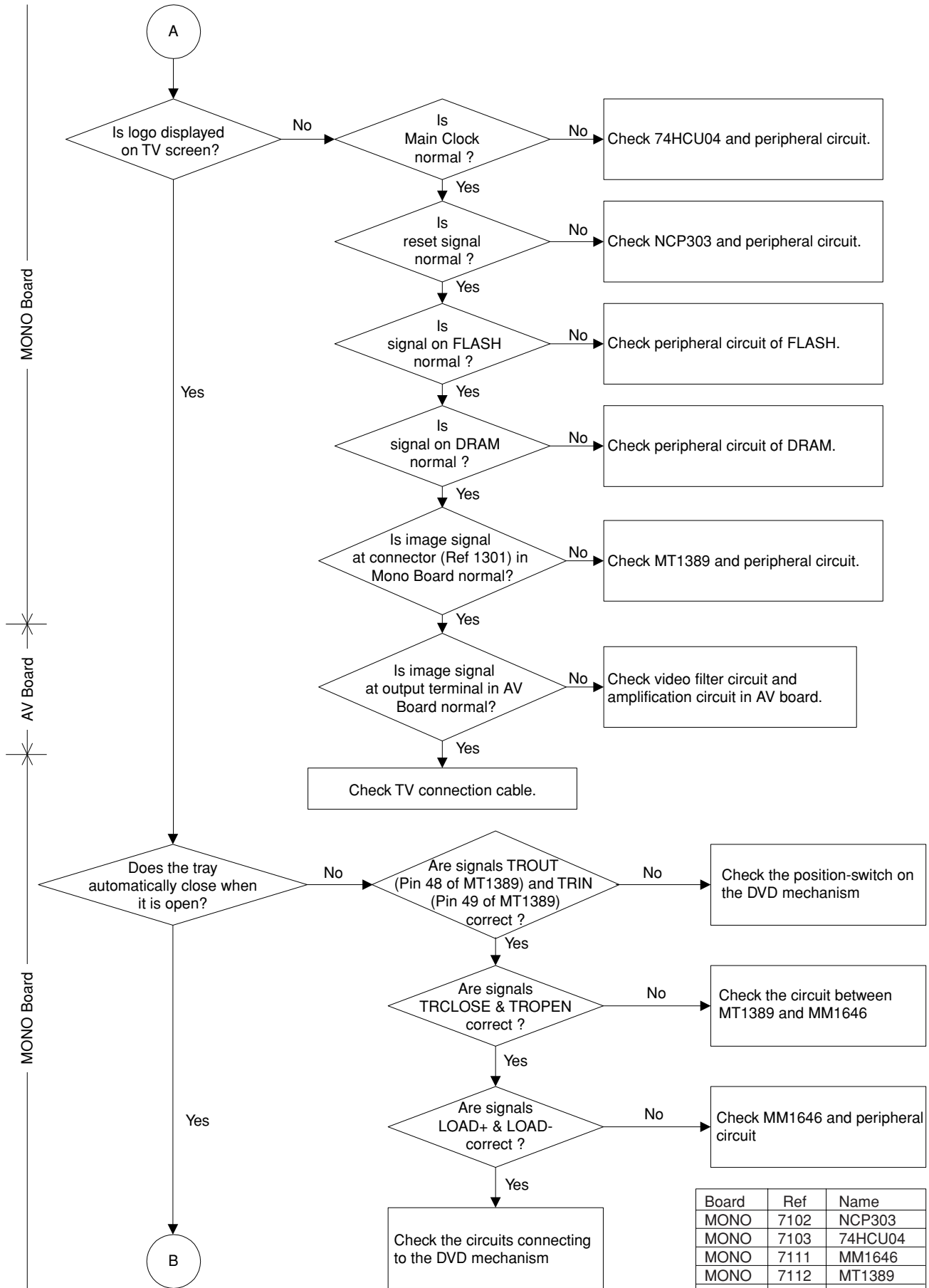

Board	Ref	Name
MONO	7102	NCP303
MONO	7103	74HCU04
MONO	7111	MM1646
MONO	7112	MT1389
MONO	7302	DRAM 64M
MONO	7303	FLASH 16M

MONO Board

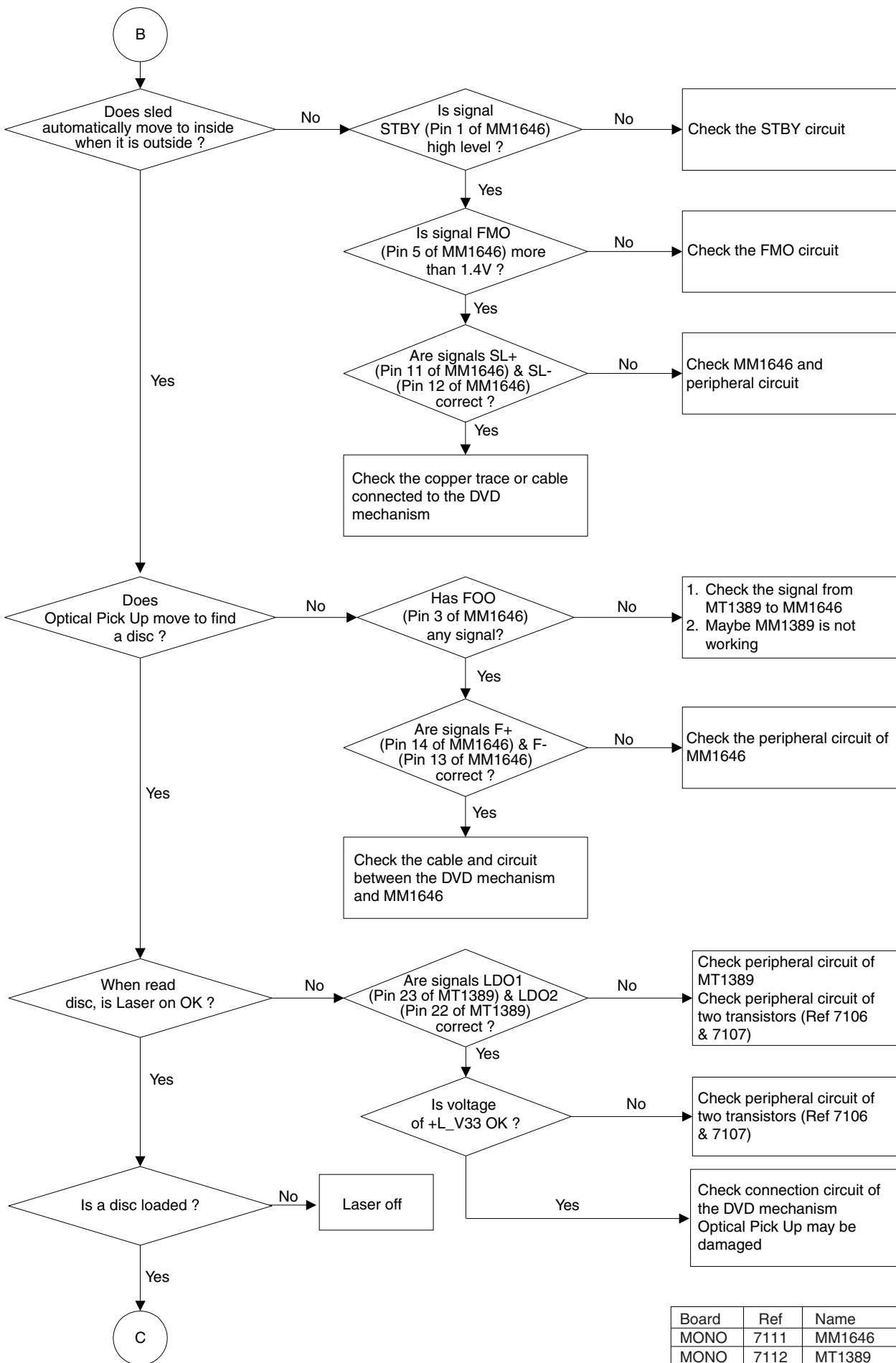

Board	Ref	Name
MONO	7111	MM1646
MONO	7112	MT1389

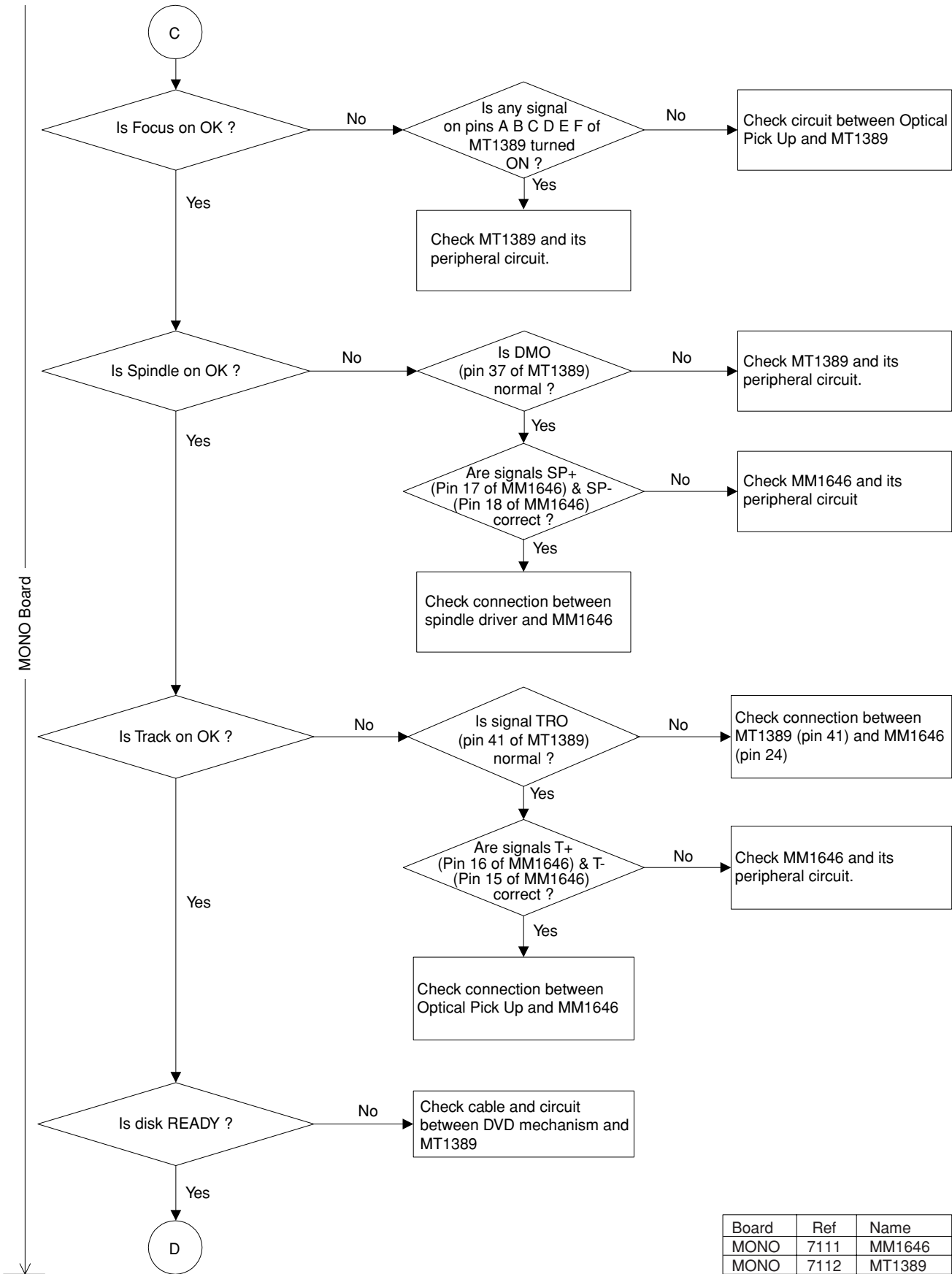

Board	Ref	Name
MONO	7111	MM1646
MONO	7112	MT1389

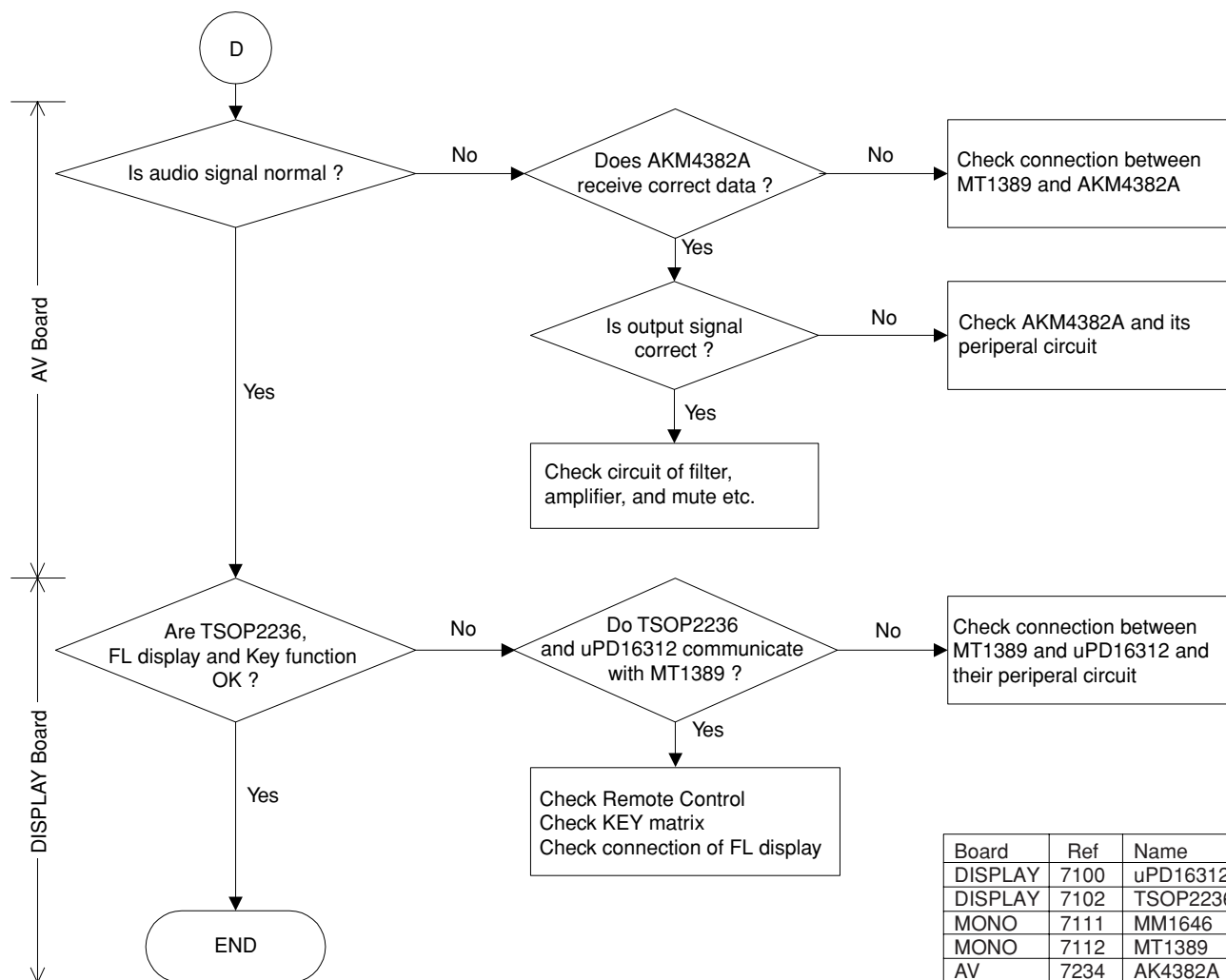

Board	Ref	Name
DISPLAY	7100	uPD16312
DISPLAY	7102	TSOP2236
MONO	7111	MM1646
MONO	7112	MT1389
AV	7234	AK4382A

■ メンテナンスフローチャート

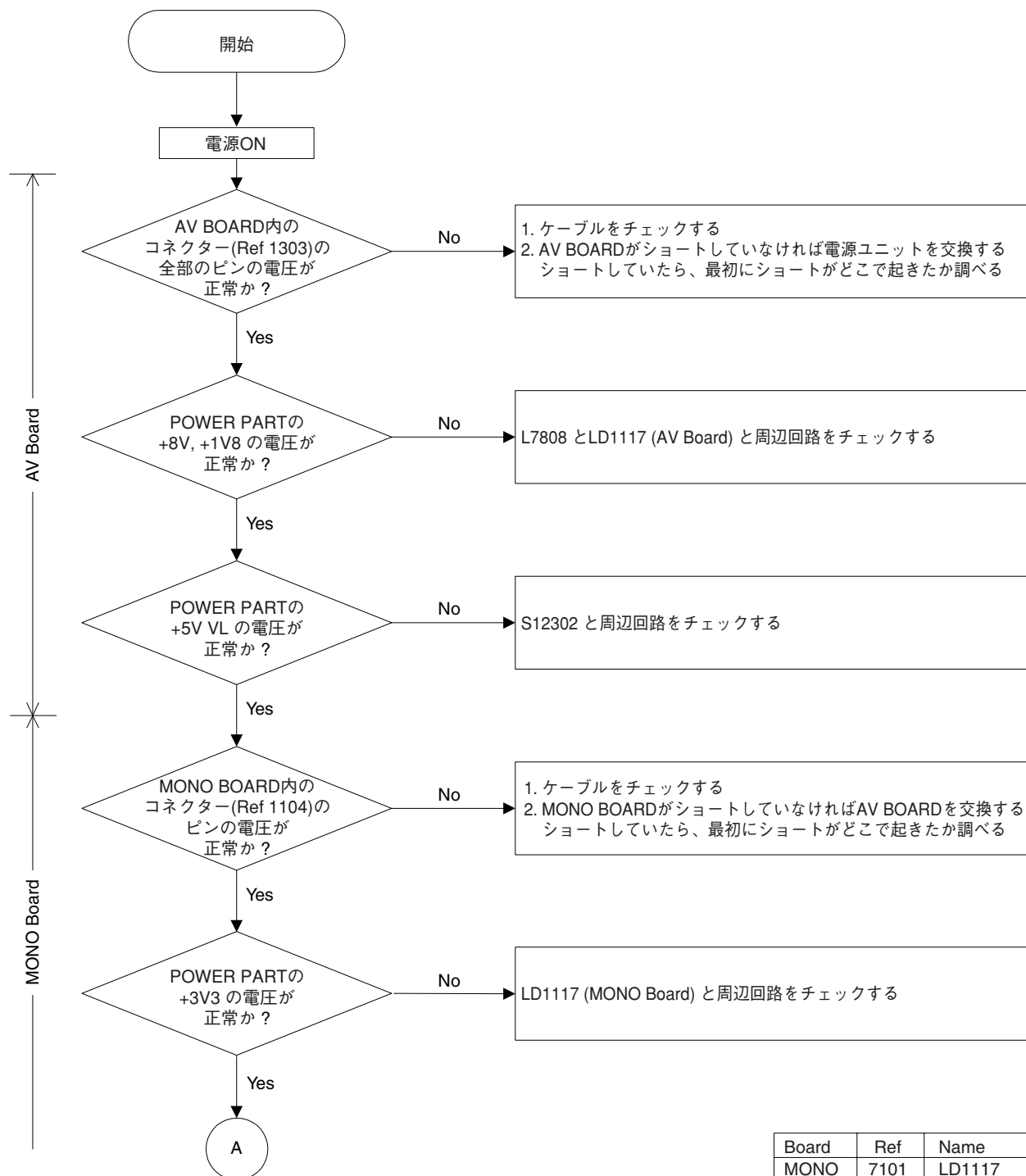

Board	Ref	Name
MONO	7101	LD1117
AV	7301	L7808
AV	7303	LD1117
AV	7306	S12302

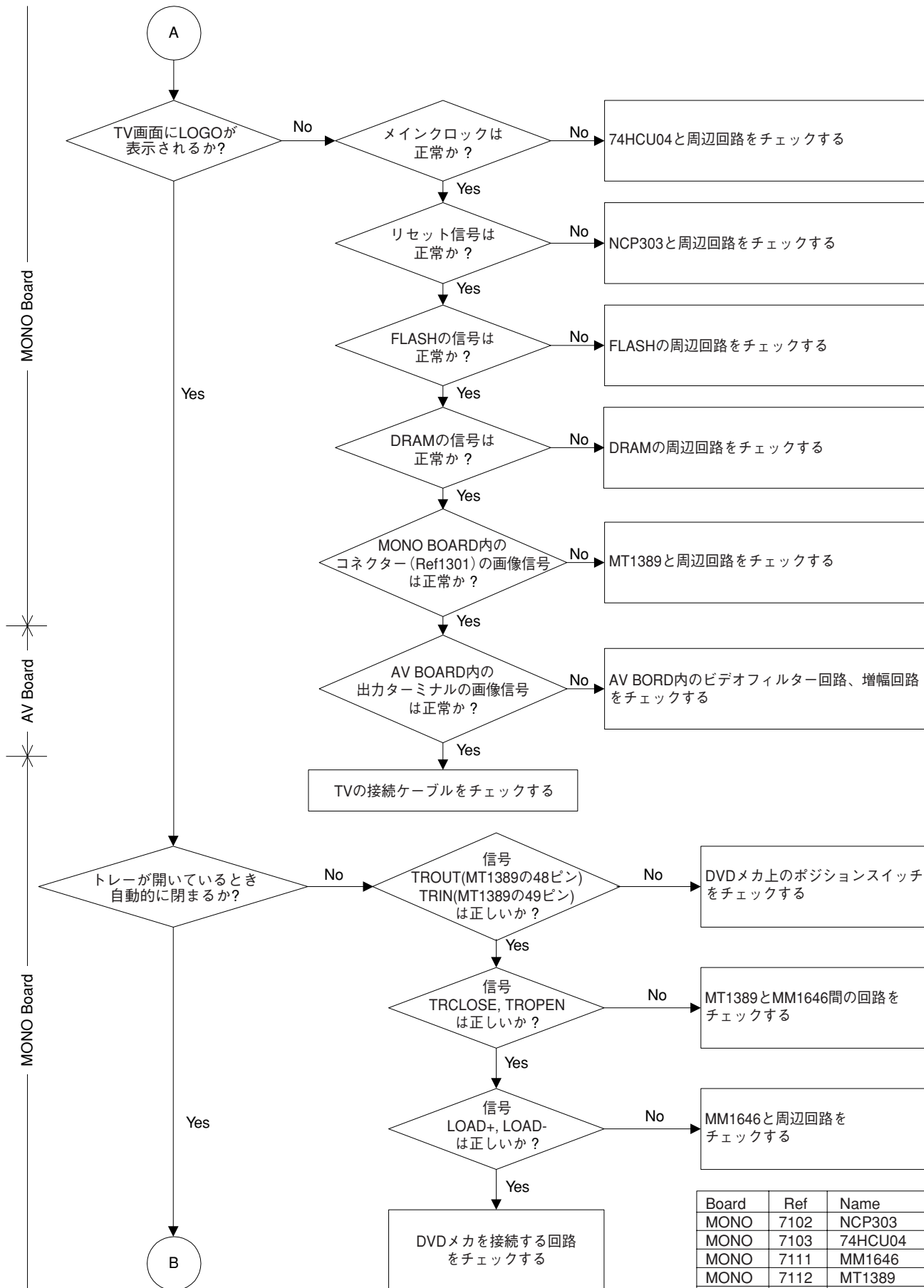

Board	Ref	Name
MONO	7102	NCP303
MONO	7103	74HCU04
MONO	7111	MM1646
MONO	7112	MT1389
MONO	7302	DRAM 64M
MONO	7303	FLASH 16M

MONO Board

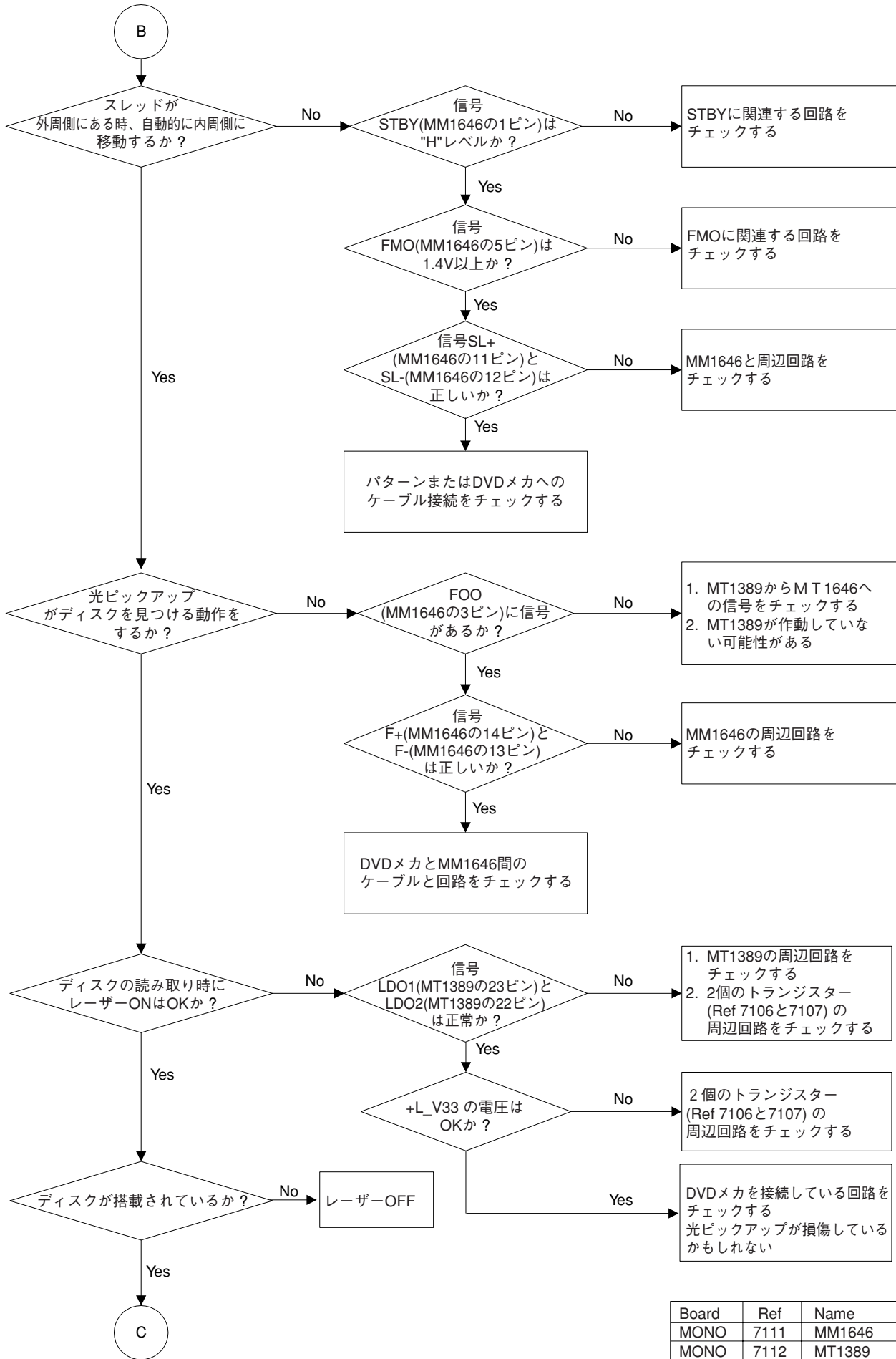

Board	Ref	Name
MONO	7111	MM1646
MONO	7112	MT1389

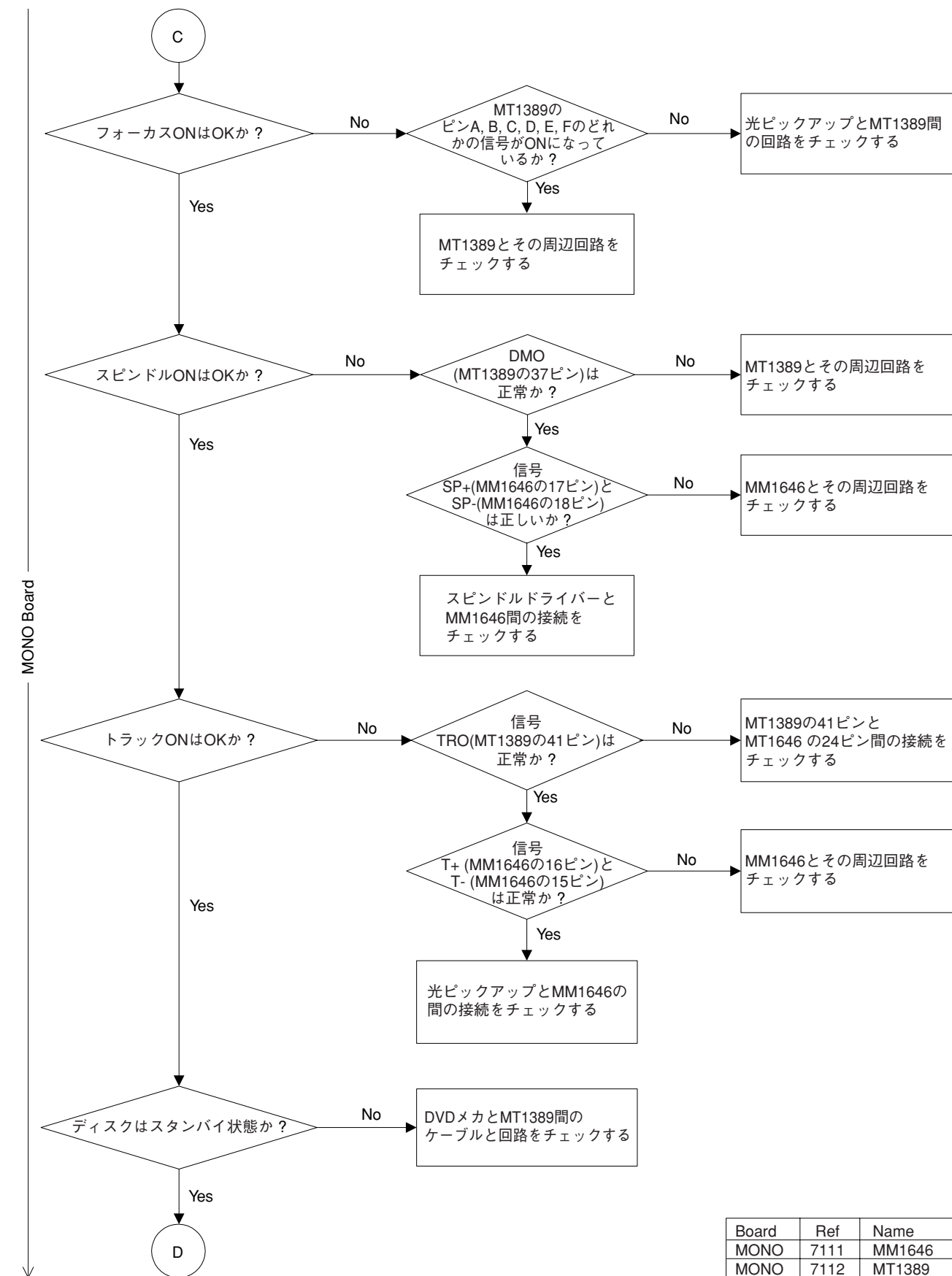

Board	Ref	Name
MONO	7111	MM1646
MONO	7112	MT1389

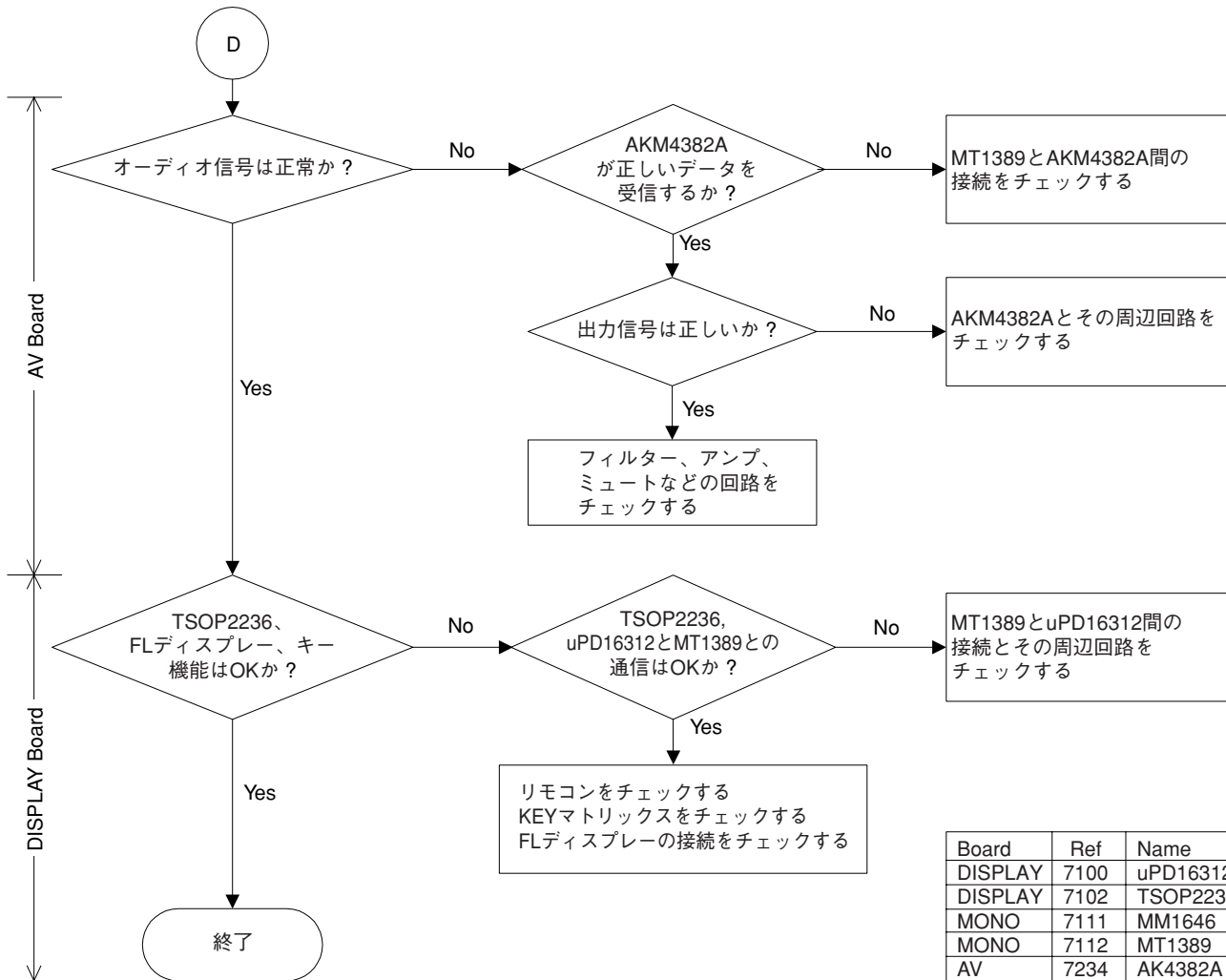

Board	Ref	Name
DISPLAY	7100	uPD16312
DISPLAY	7102	TSOP2236
MONO	7111	MM1646
MONO	7112	MT1389
AV	7234	AK4382A

BLOCK DIAGRAM

1
2
3
4
5
6

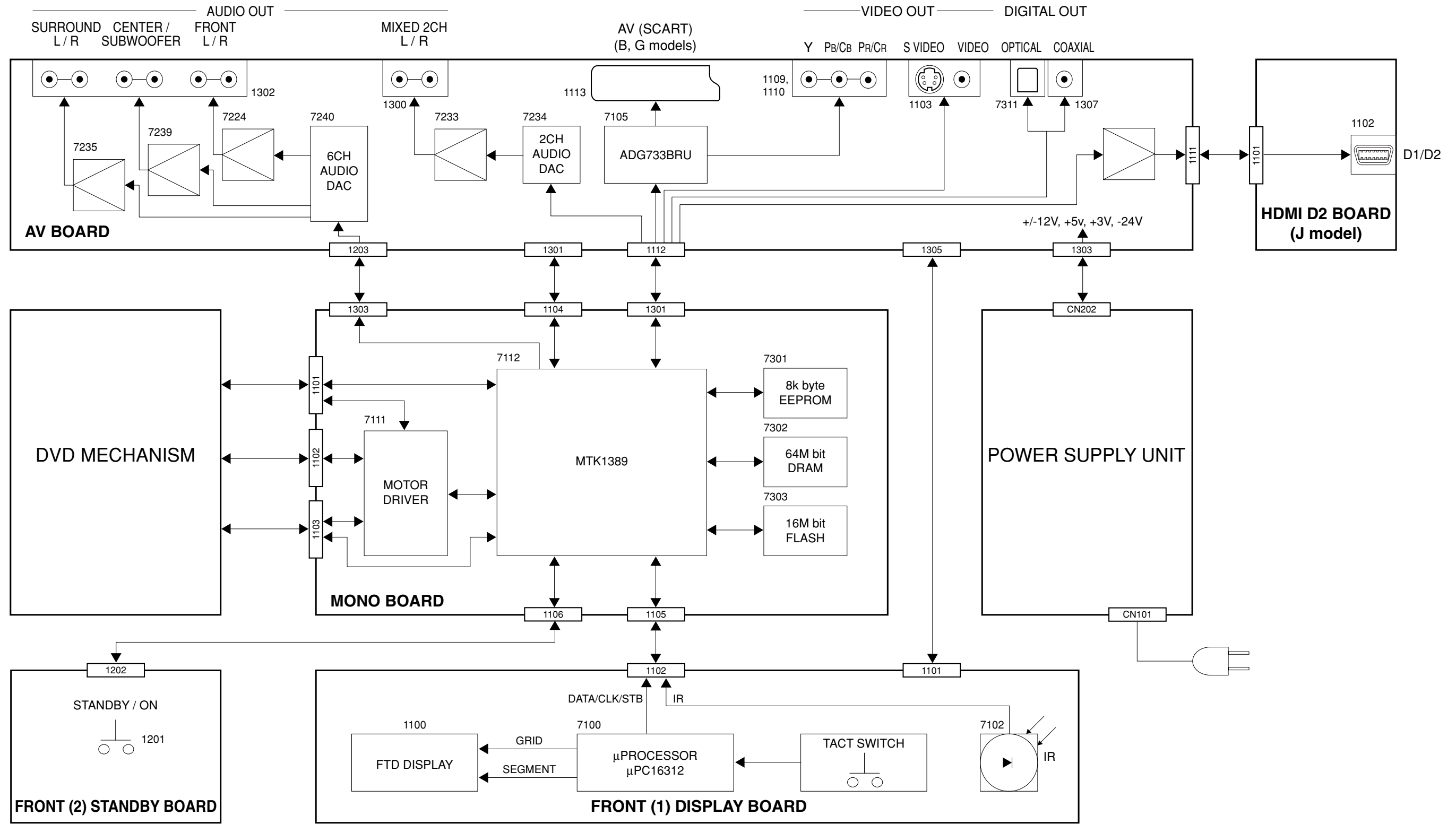

WIRING DIAGRAM

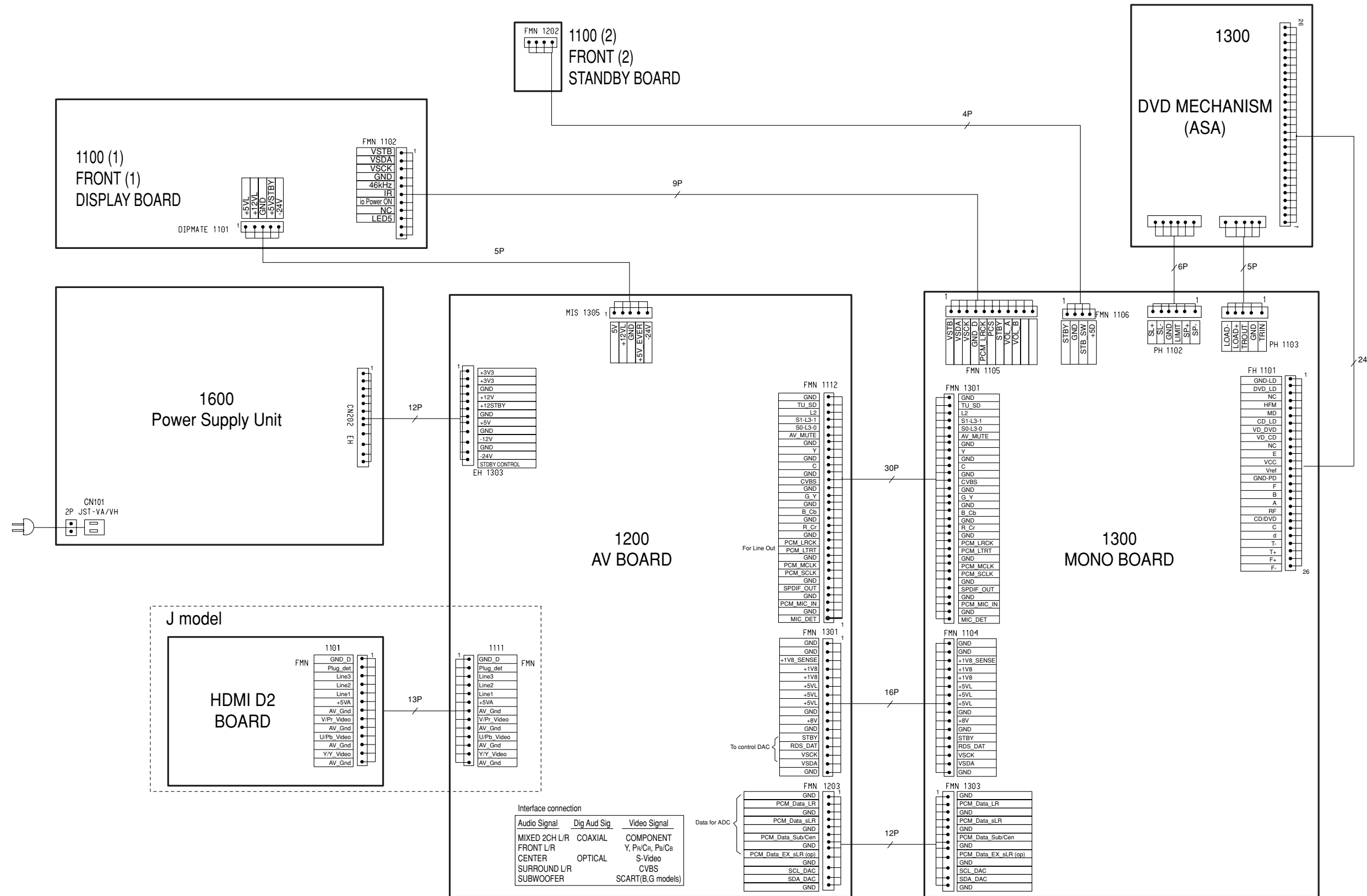

PRINTED CIRCUIT BOARD
FOR INFORMATION ONLY (NO SERVICE PARTS WILL BE AVAILABLE)

The first digit of a component indicates the component type.
 1xxx : Connector 3xxx : Resistor 5xxx : Coil 7xxx : IC, Transistor, FET
 2xxx : Capacitor 4xxx : SMD jumper 6xxx : Diode 9xxx : Wire jumper

MONO Board-Top View

MONO Board-Bottom View

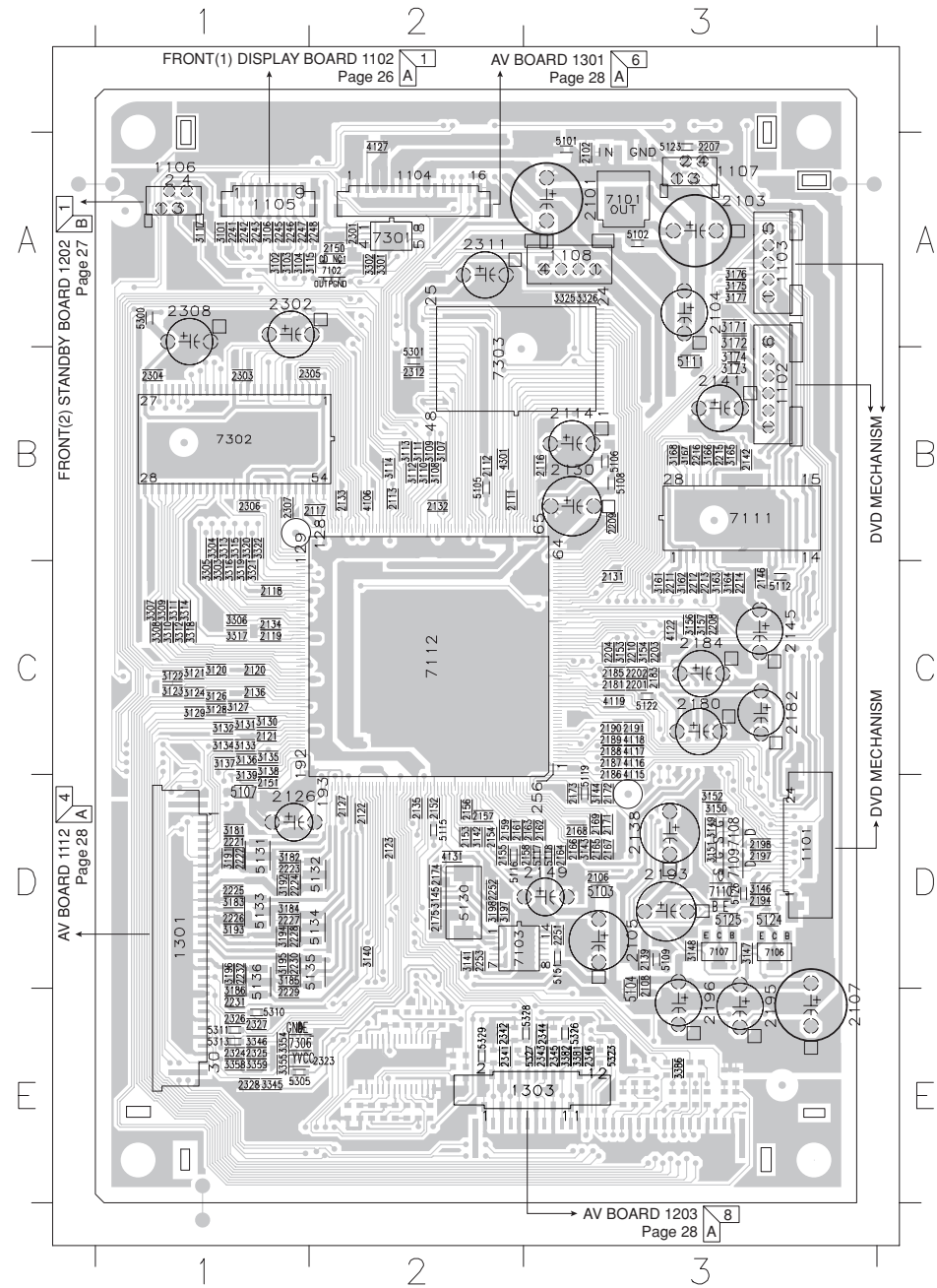

1101	D3	2172	D3	2311	A2	3162	C3	4119	C3
1102	B3	2173	D3	2312	B2	3163	C3	4122	C3
1103	A3	2174	D2	2323	E1	3164	C3	4127	A2
1104	A2	2175	D2	2324	E1	3165	B3	4131	D2
1105	A1	2180	C3	2325	E1	3166	B3	4301	B2
1106	A1	2181	C3	2326	E1	3167	B3	5101	A3
1107	A3	2182	C3	2327	E1	3168	B3	5102	A3
1108	A3	2183	C3	2328	E1	3171	A3	5103	D3
1301	D1	2184	C3	2341	E3	3172	A3	5104	E3
1303	E3	2185	C3	2342	E2	3173	B3	5105	B2
2101	A3	2186	C3	2343	E3	3174	B3	5106	B3
2102	A3	2187	C3	2344	E3	3175	A3	5107	D1
2103	A3	2188	C3	2345	E3	3176	A3	5108	B3
2104	A3	2189	C3	2346	E3	3177	A3	5109	D3
2105	D3	2190	C3	3101	A1	3181	D1	5111	B3
2106	D3	2191	C3	3102	A1	3182	D1	5112	C3
2107	E3	2193	D3	3103	A1	3183	D1	5115	D2
2108	D3	2194	D3	3104	A1	3184	D1	5116	D2
2111	B2	2195	E3	3106	A1	3185	D1	5117	D3
2112	B2	2196	E3	3107	B2	3186	E1	5118	D3
2113	B2	2197	D3	3108	B2	3191	D1	5119	D3
2114	B3	2198	D3	3109	B2	3192	D1	5122	C3
2116	B3	2201	C3	3110	B2	3193	D1	5123	A3
2117	B2	2202	C3	3111	B2	3194	D1	5124	D3
2118	C1	2203	C3	3112	B2	3195	D1	5125	D3
2119	C1	2204	C3	3113	B2	3196	D1	5126	D3
2120	C1	2207	A3	3114	B2	3197	D2	5130	D2
2121	C1	2208	C3	3115	A2	3198	D2	5131	D1
2122	D2	2209	B3	3117	A1	3301	A2	5132	D2
2123	D2	2210	C3	3120	C1	3302	A2	5133	D1
2126	D1	2211	C3	3121	C1	3303	C1	5134	D2
2127	D2	2212	C3	3122	C1	3304	B1	5135	D2
2130	B3	2213	C3	3123	C1	3305	C1	5136	D1
2131	C3	2214	C3	3124	C1	3306	C1	5151	D3
2132	B2	2215	B3	3126	C1	3307	C1	5300	A1
2133	B2	2216	B3	3127	C1	3308	C1	5301	B2
2134	C1	2221	D1	3128	C1	3309	C1	5305	E1
2135	D2	2222	D1	3129	C1	3310	C1	5310	E1
2136	C1	2223	D1	3130	C1	3311	C1	5311	E1
2138	D3	2224	D1	3131	C1	3312	C1	5313	E1
2139	D3	2225	D1	3132	C1	3313	B1	5323	E3
2141	B3	2226	D1	3133	C1	3314	C1	5326	E3
2142	B3	2227	D1	3134	C1	3315	B1	5327	E3
2145	C3	2228	D1	3135	C1	3316	C1	5328	E3
2146	C3	2229	E1	3136	C1	3317	C1	5329	E3
2149	D3	2230	D1	3137	C1	3318	C1	7101	A3
2150	A2	2231	E1	3138	C1	3319	C1	7102	A2
2151	D1	2232	D1	3139	D1	3320	B1	7103	D2
2152	D2	2241	A1	3140	D2	3321	C1	7106	D3
2153	D2	2242	A1	3141	D2	3322	B1	7107	D3
2154	D2	2243	A1	3142	D2	3325	A3	7108	D3
2155	D2	2245	A1	3143	D3	3326	A3	7109	D3
2156	D2	2246	A1	3144	D3	3345	E1	7110	D3
2157	D2	2247	A1	3145	D2	3346	E1	7111	B3
2158	D3	2248	A2	3146	D3	3354	E1	7112	C2
2159	D2	2251	D3	3147	D3	3355	E1	7301	A2
2161	D2	2252	D2	3148	D3	3358	E1	7302	B1
2162	D3	2253	D2	3149	D3	3359	E1	7303	B2
2163	D3	2301	A2	3150	D3	3381	E3	7306	E1
2164	D3	2302	A1	3151	D3	3382	E3		
2165	D3	2303	B1	3152	D3	3386	E3		
2166	D3	2304	B1	3153	C3	4106	B2		
2167	D3	2305	B2	3154	C3	4115	C3		
2168	D3	2306	B1	3156	C3	4116	C3		
2169	D3	2307	B1	3157	C3	4117	C3		
2171	D3	2308	A1	3161	C3	4118	C3		

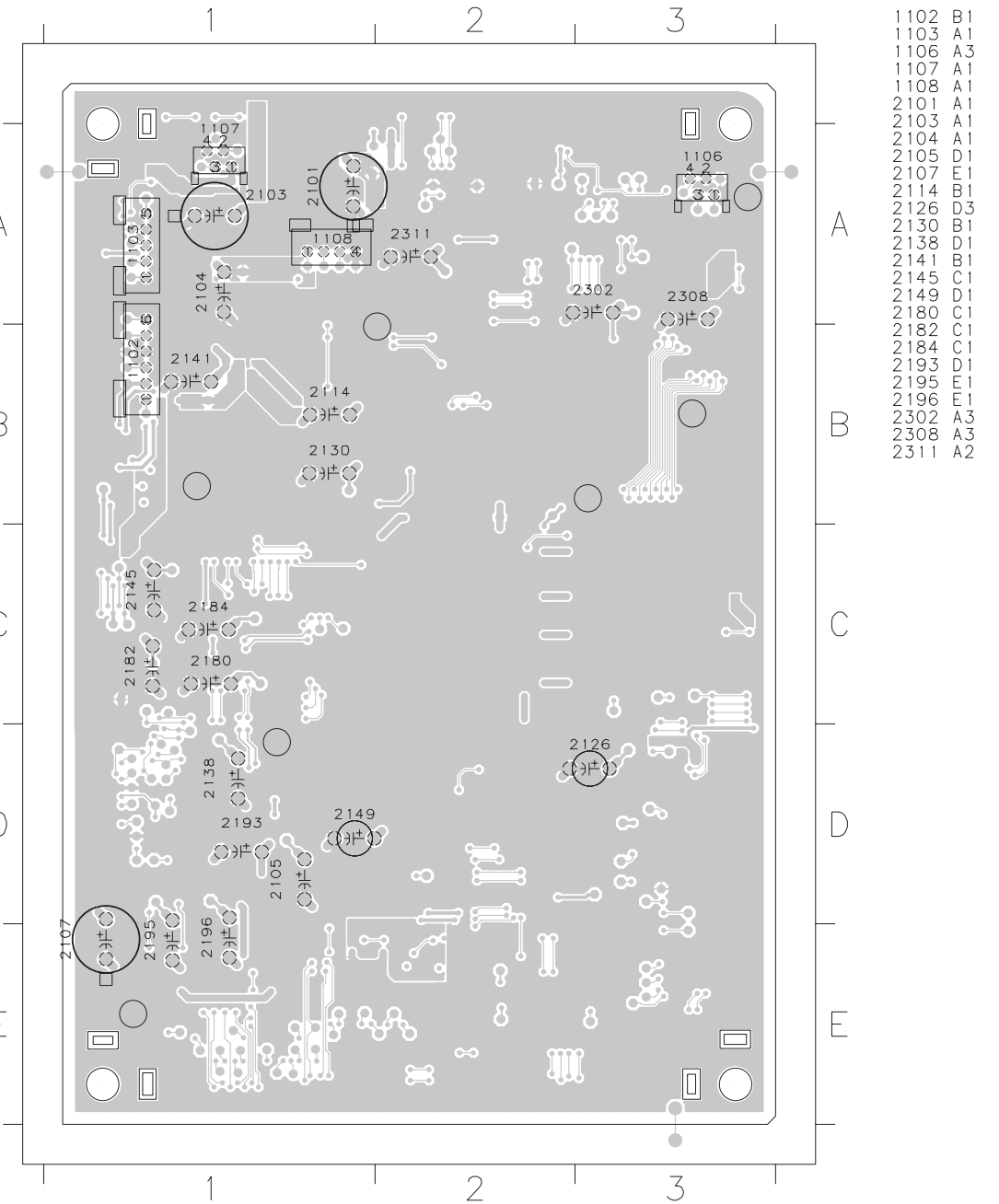

PRINTED CIRCUIT BOARD

FOR INFORMATION ONLY (NO SERVICE PARTS WILL BE AVAILABLE)

The first digit of a component indicates the component type.

1xxx : Connector 3xxx : Resistor 5xxx : Coil 7xxx : IC, Transistor, FET
 2xxx : Capacitor 4xxx : SMD jumper 6xxx : Diode 9xxx : Wire jumper

FRONT (1) Display Board-Top View

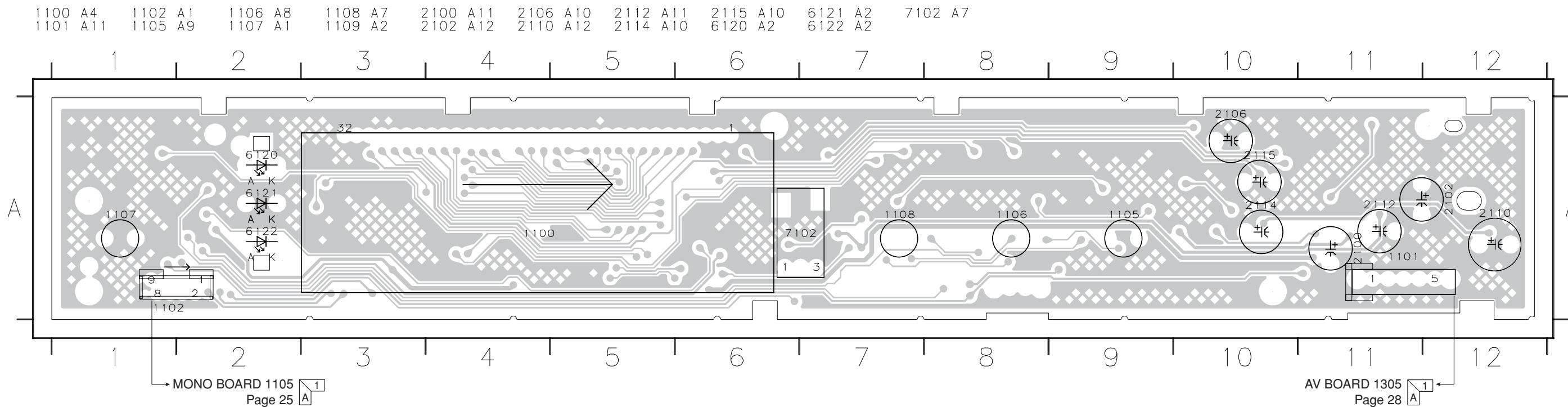

FRONT (1) Display Board-Bottom View

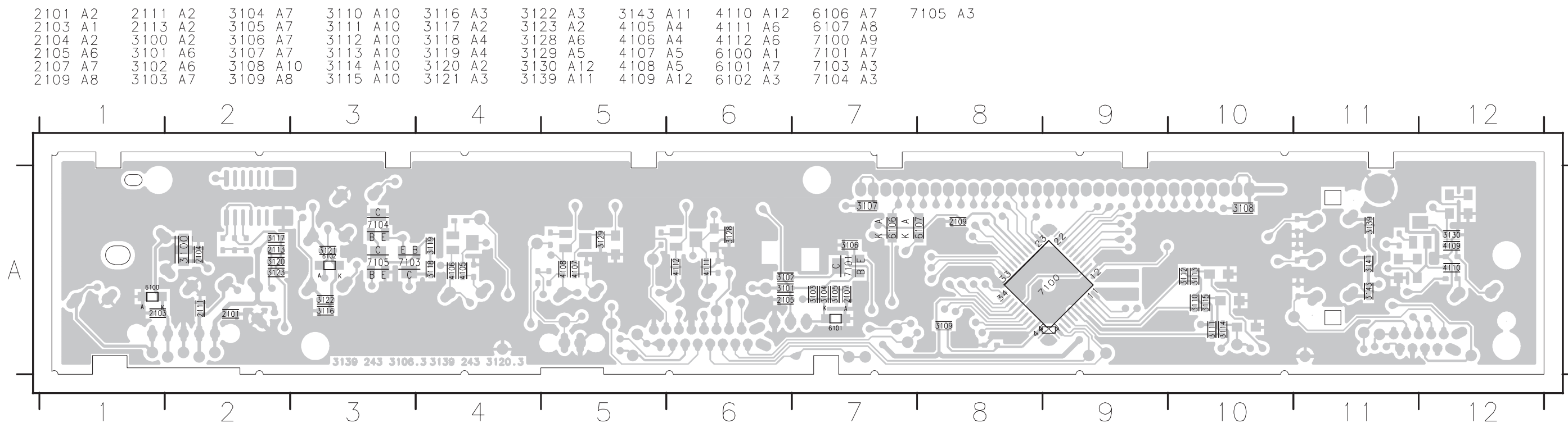

■ PRINTED CIRCUIT BOARD

FOR INFORMATION ONLY (NO SERVICE PARTS WILL BE AVAILABLE)

The first digit of a component indicates the component type.

1xxx : Connector 3xxx : Resistor 5xxx : Coil 7xxx : IC, Transistor, FET

2xxx : Capacitor 4xxx : SMD jumper 6xxx : Diode 9xxx : Wire jumper

FRONT (2) Standby Board-Top View

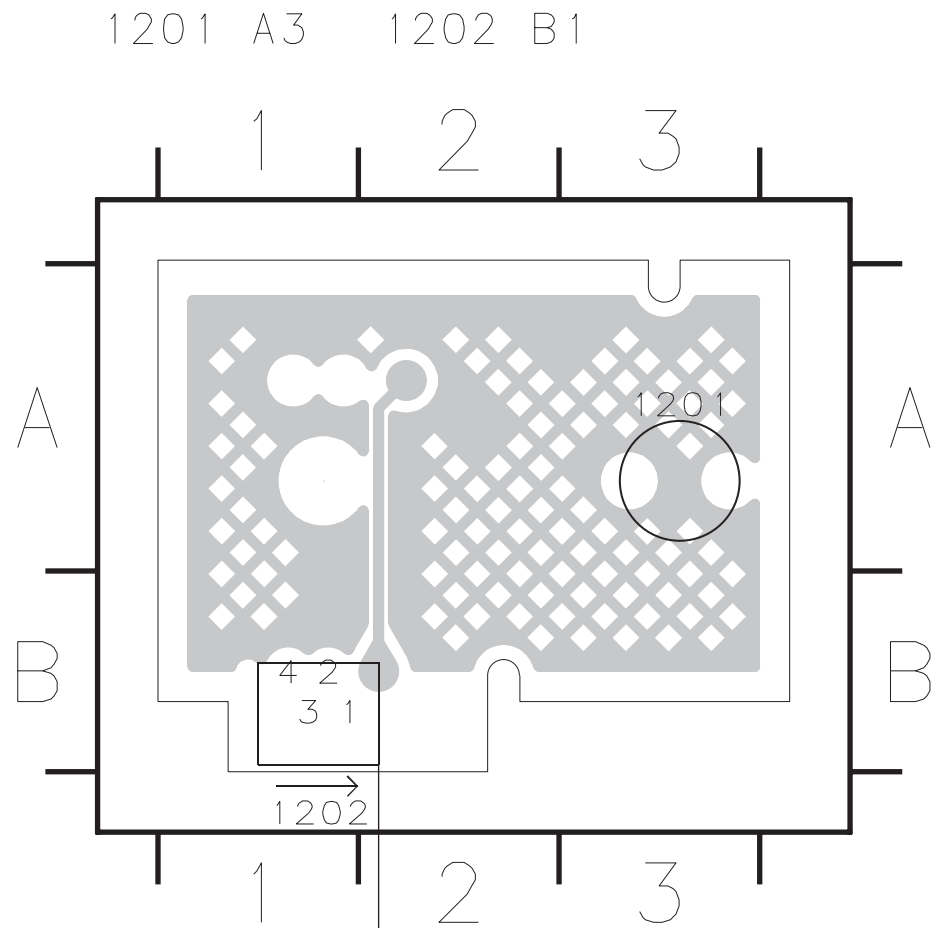

MONO BOARD 1106 1
Page 25 A

FRONT (2) Standby Board-Bottom View

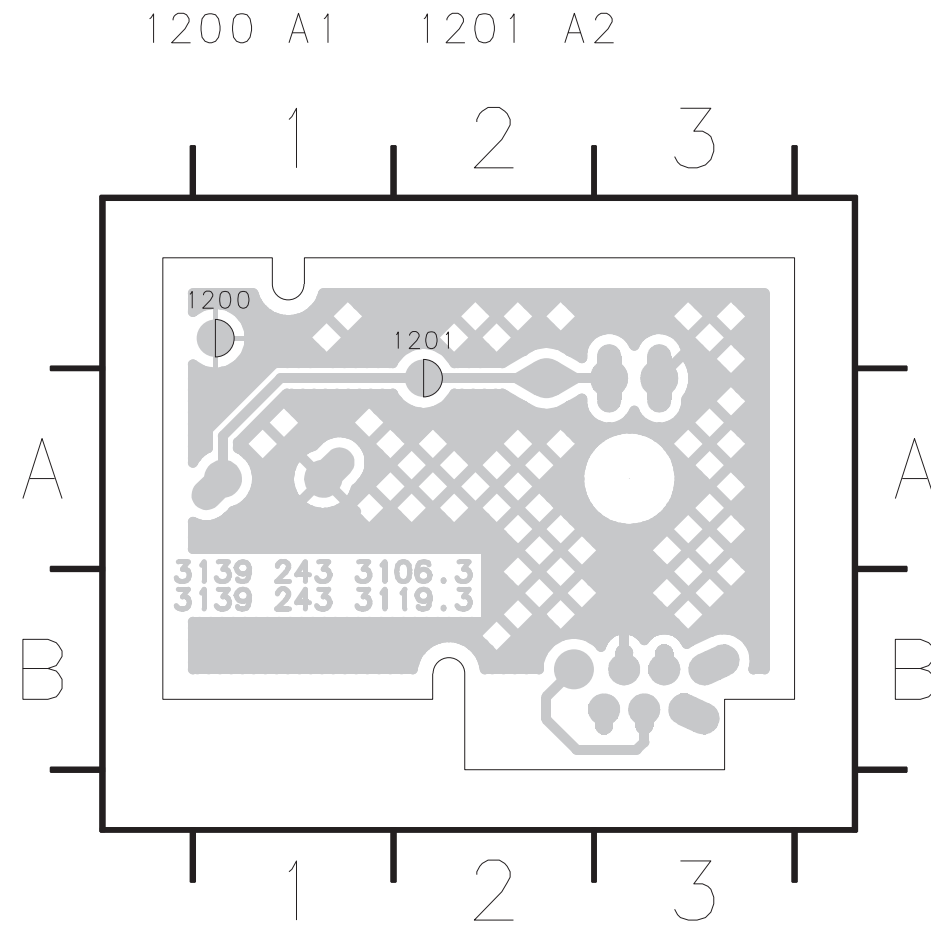

PRINTED CIRCUIT BOARD

FOR INFORMATION ONLY (NO SERVICE PARTS WILL BE AVAILABLE)

AV Board-Top View

The first digit of a component indicates the component type.

- 1xxx : Connector 3xxx : Resistor 5xxx : Coil 7xxx : IC, Transistor, FET
- 2xxx : Capacitor 4xxx : SMD jumper 6xxx : Diode 9xxx : Wire jumper

AV BOARD

Ref. No.	J	U	R	K	A	P	B	G
2101	X		O				X	
2115	O		X				X	
2118	O		X				X	
2124	O		X				X	
2172	X		O				X	
3111	O		O				O	
3117	O		O				O	
3123	O		O				O	
3179	O		O				O	
4100	X		O				O	
4101	X		O				O	
4103	X		O				O	
4104	X		O				O	
4105	X		O				O	
4106	X		O				O	
4107	O		O				X	
4107	O		O				X	
4108	X		O				O	
4110	O		O				X	
4111	X		O				O	
4112	X		O				O	
4113	X		O				X	
4114	X		O				O	
4115	X		O				X	
6100	X		O				X	
6101	X		O				X	
6104	X		O				X	

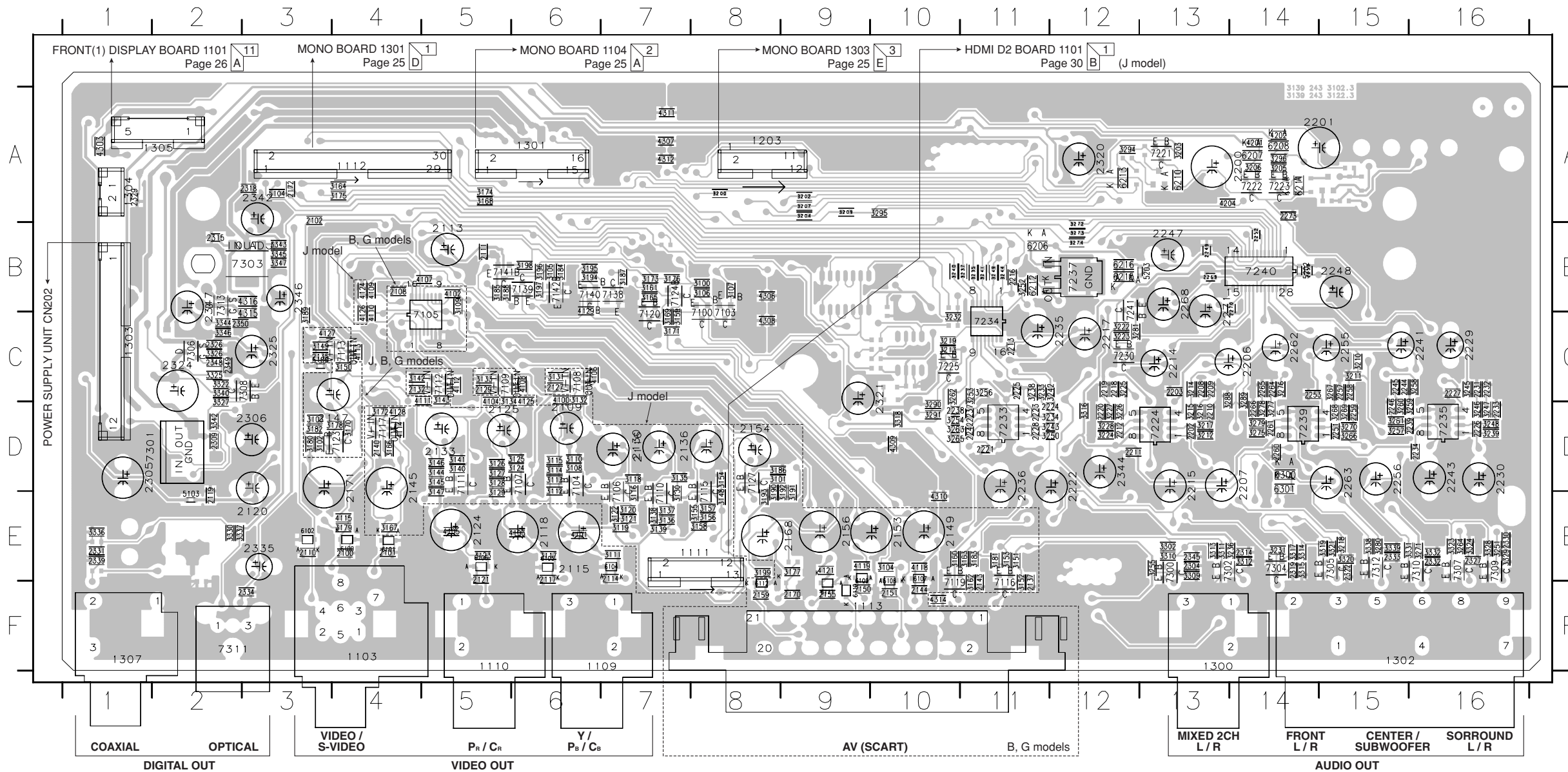

■ PRINTED CIRCUIT BOARD

FOR INFORMATION ONLY (NO SERVICE PARTS WILL BE AVAILABLE)

AV Board-Bottom View

The first digit of a component indicates the component type.

- 1xxx : Connector 3xxx : Resistor 5xxx : Coil 7xxx : IC, Transistor, FET
- 2xxx : Capacitor 4xxx : SMD jumper 6xxx : Diode 9xxx : Wire jumper

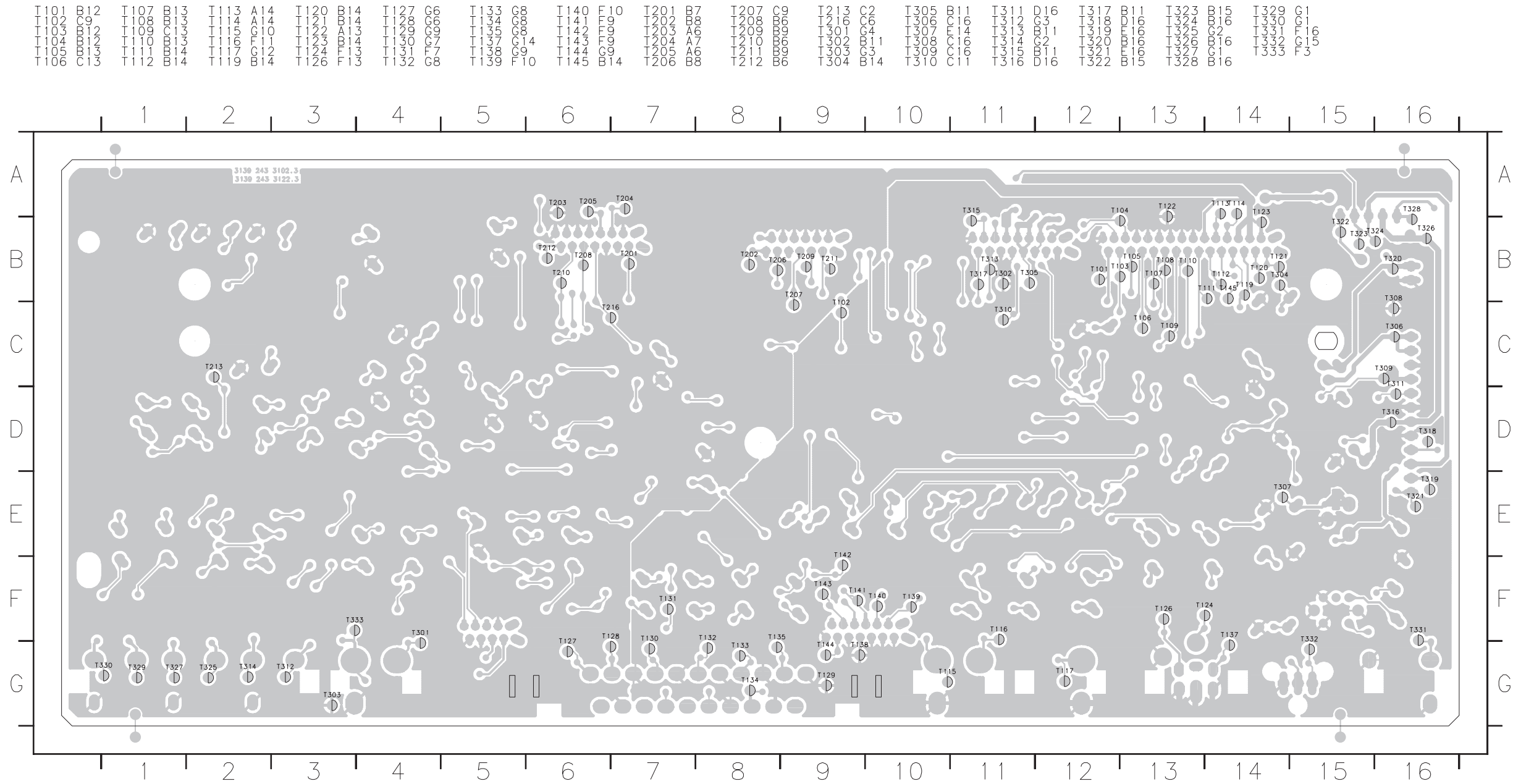

■ PRINTED CIRCUIT BOARD

FOR INFORMATION ONLY (NO SERVICE PARTS WILL BE AVAILABLE)

The first digit of a component indicates the component type.

1xxx : Connector 3xxx : Resistor 5xxx : Coil 7xxx : IC, Transistor, FET
 2xxx : Capacitor 4xxx : SMD jumper 6xxx : Diode 9xxx : Wire jumper

HDMI D2 Board-Top View J model

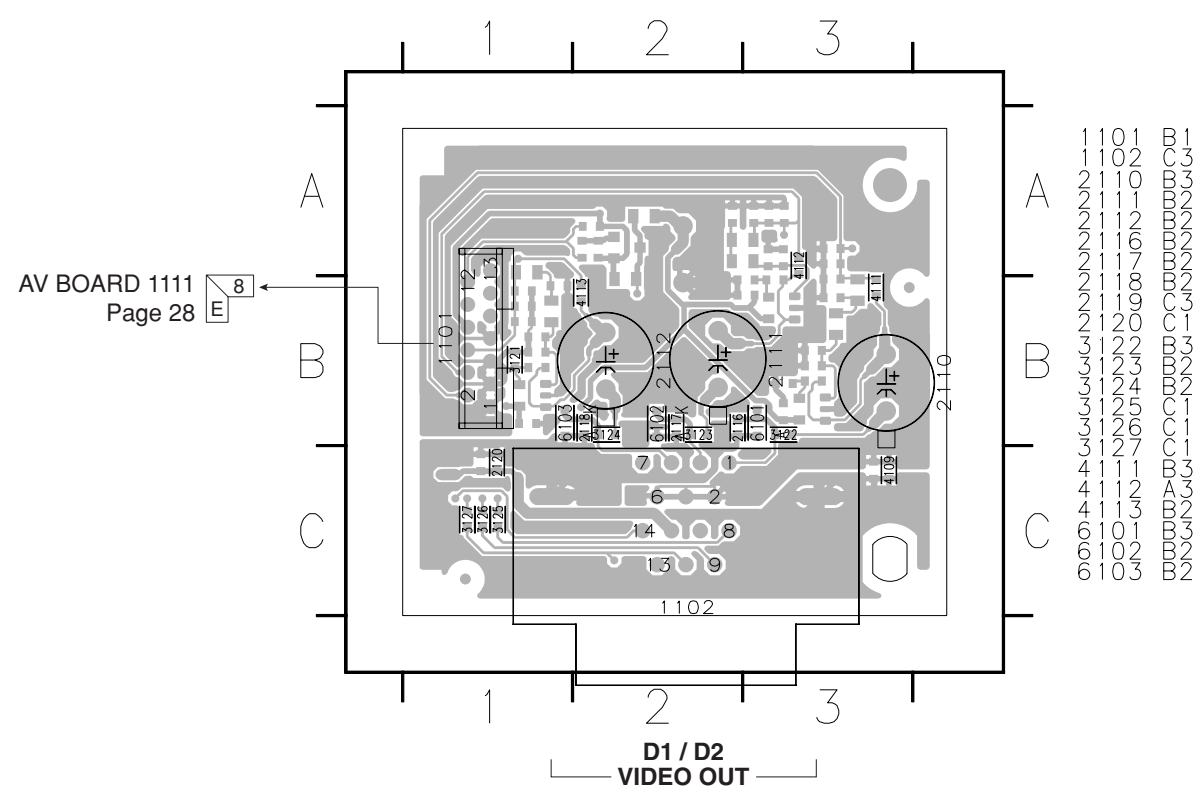

HDMI D2 Board-Bottom View J model

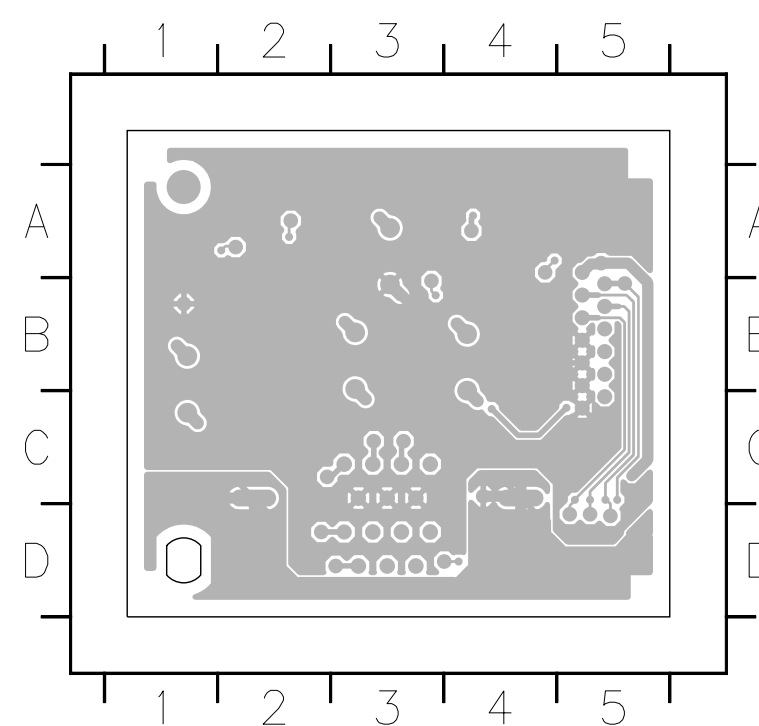

1	101	B1
1	102	C3
2	110	B3
2	111	B2
2	112	B2
2	116	B2
2	117	B2
2	118	B2
2	119	C3
2	120	C1
3	122	B3
3	123	B2
3	124	B2
3	125	C1
3	126	C1
3	127	C1
4	111	B3
4	112	A3
4	113	B2
6	101	B3
6	102	B3
6	103	B2

SCHEMATIC DIAGRAM

FOR INFORMATION ONLY (NO SERVICE PARTS WILL BE AVAILABLE)

The first digit of a component indicates the component type.

- 1xxx : Connector
- 2xxx : Capacitor
- 3xxx : Resistor
- 4xxx : SMD jumper
- 5xxx : Coil
- 6xxx : Diode
- 7xxx : IC, Transistor, FET
- 8xxx : Diode
- 9xxx : Wire jumper

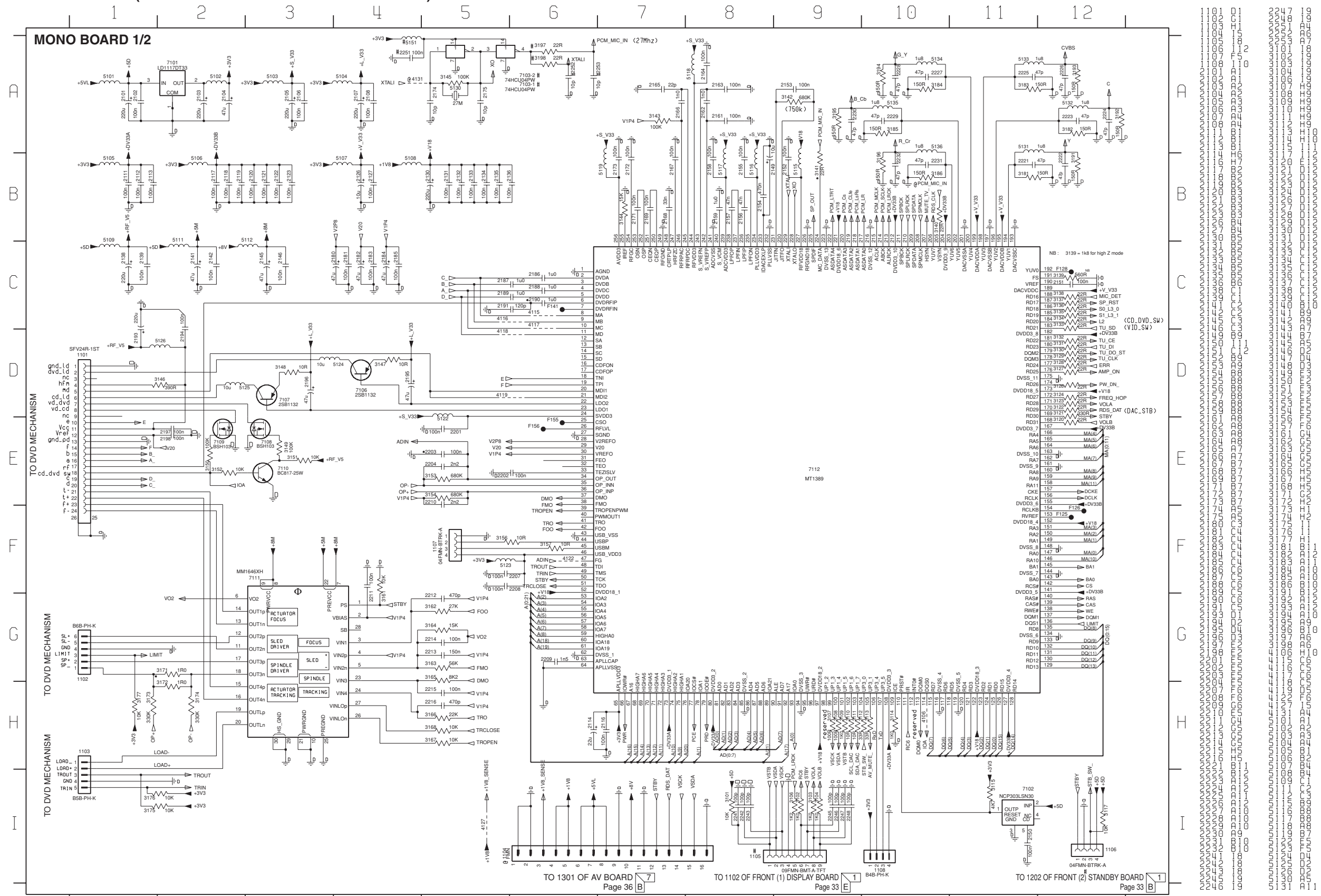

★ Components having special characteristics are marked Δ and must be replaced with parts having specifications equal to those originally installed.
 ★ Schematic diagram is subject to change without notice.

● Δ 印のある部品は、安全性確保部品を示しています。部品の交換が必要な場合、パーツリストに記載されている部品を使用してください。
 ● 本回路図は標準回路図です。改良のため予告なく変更することがございます。

■ SCHEMATIC DIAGRAM

FOR INFORMATION ONLY (NO SERVICE PARTS WILL BE AVAILABLE)

The first digit of a component indicates the component type.

- 1xxx : Connector 3xxx : Resistor 5xxx : Coil 7xxx : IC, Transistor, FET
- 2xxx : Capacitor 4xxx : SMD jumper 6xxx : Diode 9xxx : Wire jumper

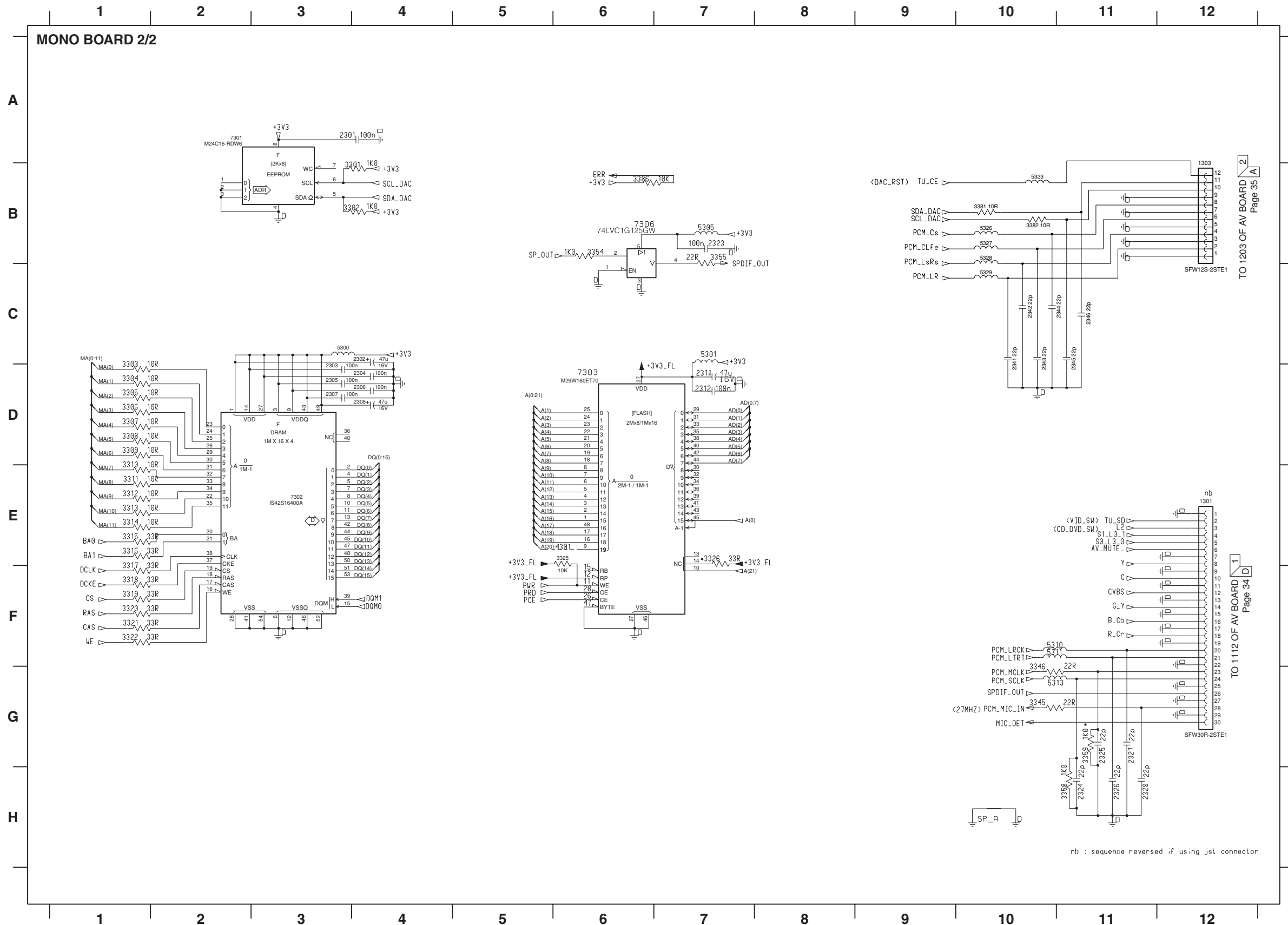

- 1301 E12
- 1303 B12
- 2301 A3
- 2302 D4
- 2303 D3
- 2304 D4
- 2305 D3
- 2306 D4
- 2307 D3
- 2308 D4
- 2311 D7
- 2312 D7
- 2323 D11
- 2324 H11
- 2326 H11
- 2327 H11
- 2328 H11
- 2341 C10
- 2342 C10
- 2343 C10
- 2344 C10
- 2345 C11
- 2346 C11
- 3301 B4
- 3302 B4
- 3303 D1
- 3304 D1
- 3305 D1
- 3306 D1
- 3307 D1
- 3308 D1
- 3309 D1
- 3310 E1
- 3311 E1
- 3312 E1
- 3313 E1
- 3314 E1
- 3315 E1
- 3316 E1
- 3317 F1
- 3318 F1
- 3319 F1
- 3320 F1
- 3321 F1
- 3322 F1
- 3325 E6
- 3326 E7
- 3345 G10
- 3346 G10
- 3354 D9
- 3355 D11
- 3358 H11
- 3359 G11
- 3381 B10
- 3382 B10
- 3386 C10
- 4301 E6
- 5300 C3
- 5301 C7
- 5305 D10
- 5310 F10
- 5313 G10
- 5323 B10
- 5326 B10
- 5327 B10
- 5328 B10
- 5329 C10
- 7301 A2
- 7302 D2
- 7303 D6
- 7306 D10

★ Components having special characteristics are marked Δ and must be replaced with parts having specifications equal to those originally installed.
★ Schematic diagram is subject to change without notice.

● Δ 印のある部品は、安全性確保部品を示しています。部品の交換が必要な場合、パーツリストに記載されている部品を使用してください。
● 本回路図は標準回路図です。改良のため予告なく変更することがございます。

SCHEMATIC DIAGRAM

FOR INFORMATION ONLY (NO SERVICE PARTS WILL BE AVAILABLE)

The first digit of a component indicates the component type.

- 1xxx : Connector 3xxx : Resistor 5xxx : Coil 7xxx : IC, Transistor, FET
- 2xxx : Capacitor 4xxx : SMD jumper 6xxx : Diode 9xxx : Wire jumper

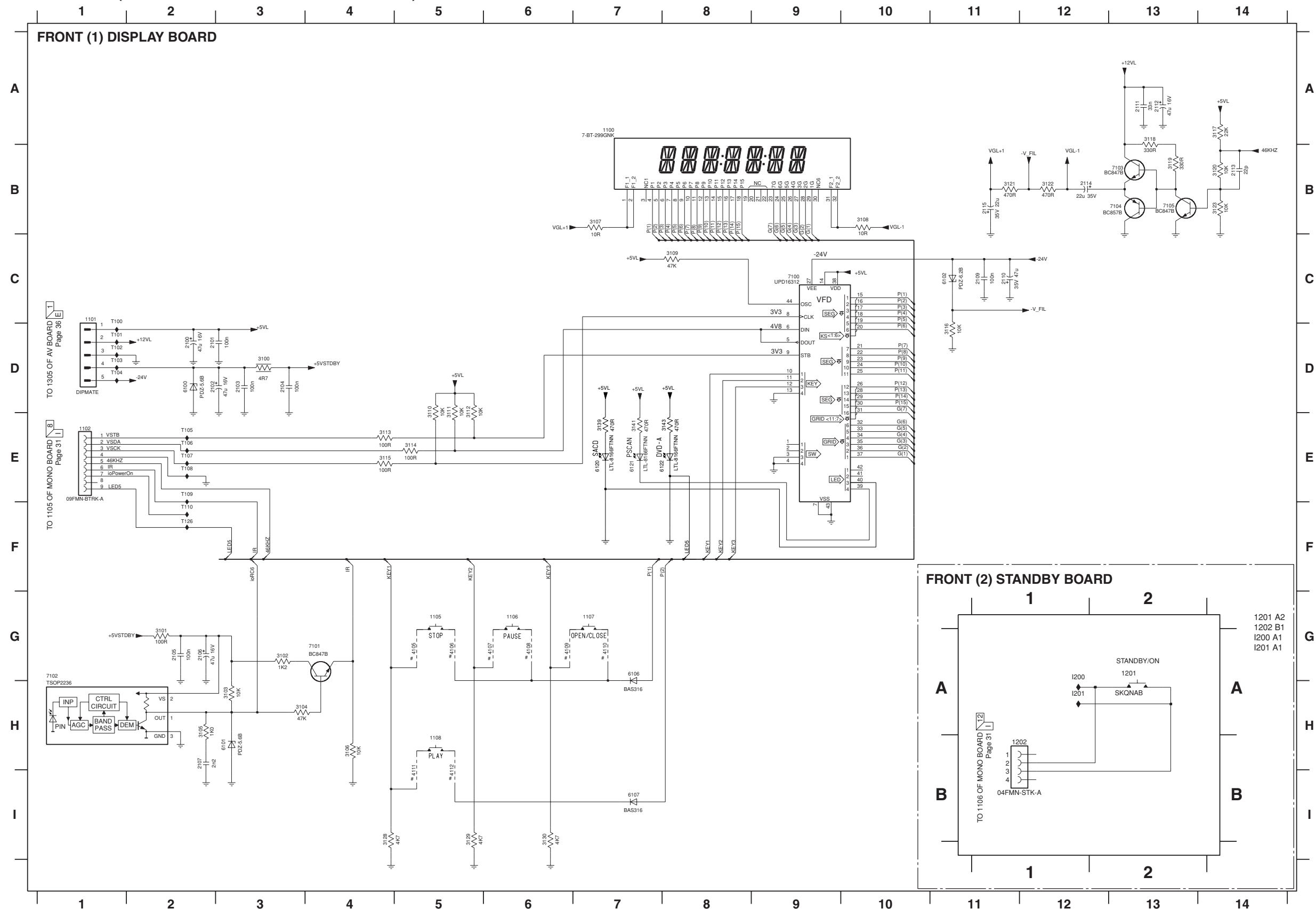

- 1100 A7
- 1101 C1
- 1102 E1
- 1103 A1
- 1104 C1
- 1105 G5
- 1106 G6
- 1107 G7
- 1108 H5
- 2100 D2
- 2101 D2
- 2102 D2
- 2103 D3
- 2104 D3
- 2105 G2
- 2106 G2
- 2107 H2
- 2109 C11
- 2110 C11
- 2111 A13
- 2112 A13
- 2113 B4
- 2114 B12
- 2115 B11
- 3100 D3
- 3101 G2
- 3102 G3
- 3103 H3
- 3104 H3
- 3105 D5
- 3106 H4
- 3107 B7
- 3108 B10
- 3109 C8
- 3110 D5
- 3111 D5
- 3112 D5
- 3113 E4
- 3114 E5
- 3115 E4
- 3116 D11
- 3117 A14
- 3118 A13
- 3119 B13
- 3120 B14
- 3121 B11
- 3122 B12
- 3123 B14
- 3128 I4
- 3129 I5
- 3130 I6
- 3132 G10
- 3139 E7
- 3141 E7
- 3143 E8
- 4103 H5
- 4105 G5
- 4106 G5
- 4107 B3
- 4108 G6
- 4109 G6
- 4110 G7
- 4111 H5
- 4112 H5
- 6100 D2
- 6101 H3
- 6102 C11
- 6106 G7
- 6107 I7
- 6120 E7
- 6121 E7
- 6122 E8
- 7100 C9
- 7101 G4
- 7102 G1
- 7103 B13
- 7104 B13
- 7105 B13
- 7106 G11
- T100 C1
- T101 D1
- T102 D1
- T103 D1
- T104 D1
- T105 E2
- T106 E2
- T107 E2
- T108 E2
- T109 E2
- T110 F2
- T111 A2
- T112 A2
- T113 A2
- T114 A2
- T115 A2
- T116 A2
- T117 A2
- T118 A2
- T119 B2
- T120 B2
- T121 B2
- T122 B2
- T123 B2
- T124 B2
- T125 B2
- T126 F2

★ Components having special characteristics are marked and must be replaced with parts having specifications equal to those originally installed.
 ★ Schematic diagram is subject to change without notice.

● 印のある部品は、安全性確保部品を示しています。部品の交換が必要な場合、パーツリストに記載されている部品を使用してください。
 ● 本回路図は標準回路図です。改良のため予告なく変更することがございます。

SCHEMATIC DIAGRAM

FOR INFORMATION ONLY (NO SERVICE PARTS WILL BE AVAILABLE)

The first digit of a component indicates the component type.

- 1xxx : Connector 3xxx : Resistor 5xxx : Coil 7xxx : IC, Transistor, FET
- 2xxx : Capacitor 4xxx : SMD jumper 6xxx : Diode 9xxx : Wire jumper

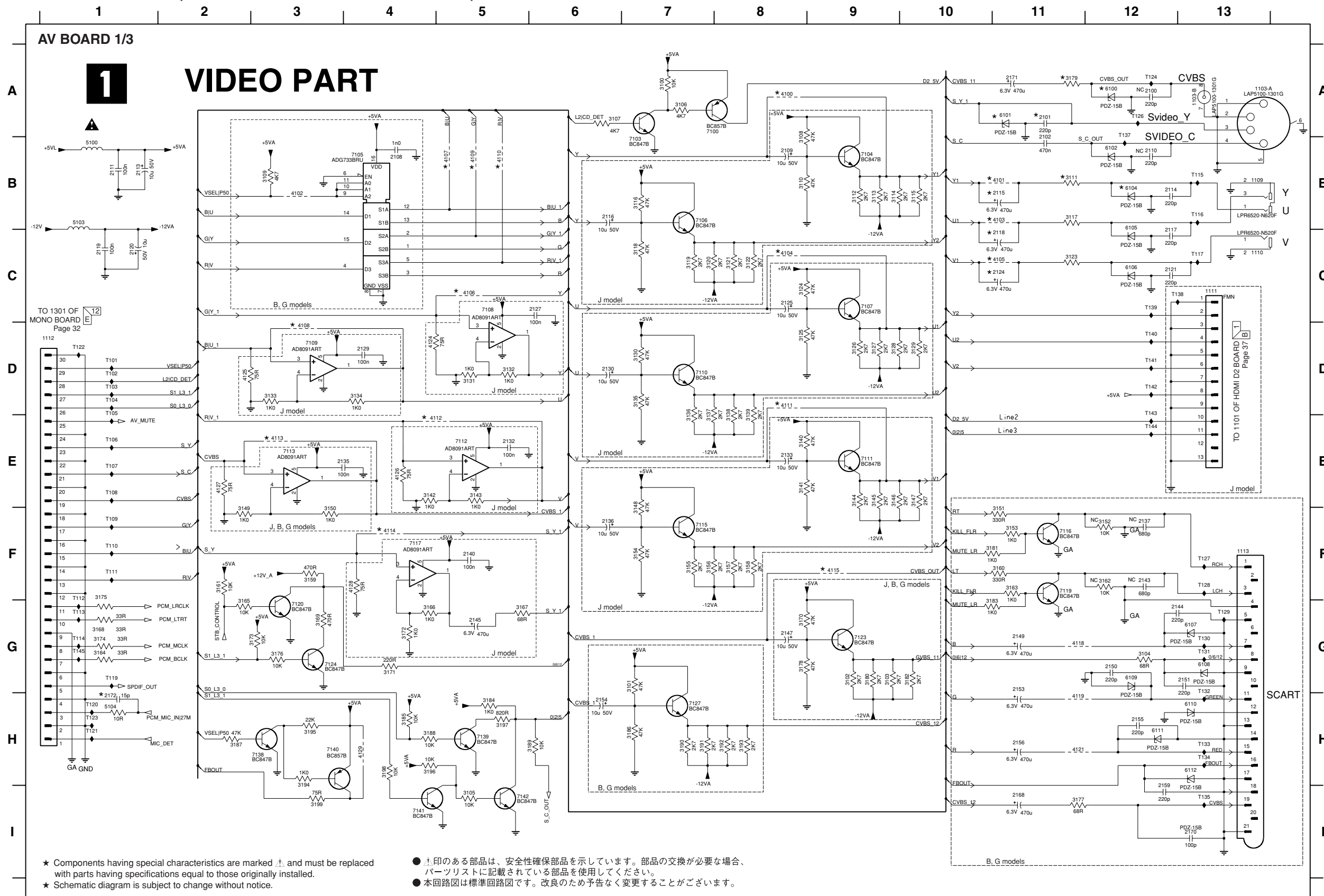

* Components having special characteristics are marked with a triangle and must be replaced with parts having specifications equal to those originally installed.
 * Schematic diagram is subject to change without notice.

● 印のある部品は、安全性確保部品を示しています。部品の交換が必要な場合、パーツリストに記載されている部品を使用してください。
 ● 本回路図は標準回路図です。改良のため予告なく変更することがございます。

1103-A A13	3162 F12	T107 E1
1103-B A13	3163 F11	T108 E1
1109 B13	3164 G1	T109 F1
1110 C13	3165 G2	T110 F1
1111 C13	3166 G4	T111 F1
1112 D1	3167 G5	T112 F1
1113 F13	3168 G1	T113 G1
2100 A12	3169 G3	T114 G1
2101 A11	3170 G8	T115 B13
2102 B11	3171 G4	T116 B13
2108 B4	3172 G4	T117 G4
2109 B8	3173 G3	T119 G1
2110 B12	3174 G1	T120 H1
2111 B1	3175 F1	T121 H1
2113 B1	3176 G3	T122 D1
2114 B12	3177 H1	T123 H1
2115 B11	3178 G8	T124 A12
2116 B6	3179 A11	T126 A12
2117 C12	3180 G9	T127 F13
2118 C11	3181 F10	T128 F13
2119 C1	3182 G10	T129 G13
2120 C1	3183 G10	T130 G13
2121 C12	3184 H5	T131 G13
2124 C11	3185 H4	T132 G13
2125 C8	3186 H7	T133 H13
2127 C6	3187 H2	T134 H13
2129 D4	3188 H4	T135 H13
2130 D6	3189 H6	T137 A12
2132 E5	3190 H7	T138 C12
2133 E8	3191 H7	T139 C12
2135 E3	3192 H8	T140 D12
2136 F6	3193 H8	T141 D12
2137 F12	3194 H3	T142 D12
2140 F5	3195 H3	T143 D12
2143 F12	3196 H4	T144 E12
2144 G12	3197 H5	T145 G1
2145 G5	3198 H4	
2147 G8	3199 J3	
2148 G11	4100 A8	
2150 G12	4101 B11	
2151 G13	4102 B3	
2153 G11	4103 B11	
2154 H6	4104 C8	
2155 H12	4105 C11	
2156 H11	4106 C5	
2159 I12	4107 B5	
2168 H1	4108 D3	
2170 H3	4109 B5	
2171 A11	4110 B5	
2172 H1	4111 D8	
3100 A7	4112 E4	
3101 G7	4113 E3	
3102 G9	4114 F4	
3103 G9	4115 F9	
3104 G12	4118 G11	
3105 I5	4119 H11	
3106 A7	4121 H11	
3107 A6	4124 D4	
3108 A8	4125 D2	
3109 B3	4126 E4	
3110 B8	4127 E2	
3111 B11	4128 F4	
3112 B9	4129 H4	
3113 B9	5100 B1	
3114 B9	5103 B1	
3115 B10	5104 H1	
3116 B7	6100 A12	
3117 B11	6101 A11	
3118 C7	6102 B12	
3119 C7	6104 B12	
3120 C7	6105 B12	
3121 C8	6106 C12	
3122 C8	6107 G13	
3123 C11	6108 G13	
3124 C8	6109 G12	
3125 D8	6110 H13	
3126 D9	6111 H12	
3127 D9	6112 H13	
3128 D9	7100 A8	
3129 D10	7103 B7	
3130 D7	7104 B9	
3131 D5	7105 B4	
3132 D5	7106 B7	
3133 D3	7107 C9	
3134 D4	7108 C5	
3135 D7	7109 D3	
3136 D7	7110 D7	
3137 D7	7111 E9	
3138 D8	7112 E5	
3139 D8	7113 E3	
3140 E8	7115 F7	
3141 E8	7116 F11	
3142 E4	7117 F4	
3143 E5	7119 F11	
3144 E9	7120 G3	
3145 E9	7123 G9	
3146 E9	7124 G3	
3147 E10	7127 H7	
3148 E7	7128 H3	
3149 F2	7139 H5	
3150 F3	7140 H3	
3151 F11	7141 I4	
3152 F12	7142 I5	
3153 F11	T101 D1	
3154 F7	T102 D1	
3155 F7	T103 D1	
3156 F7	T104 D1	
3157 F8	T105 D1	
3158 F8	T106 E1	
3159 F3		
3160 F11		
3161 F2		

*	4107	4107	4110	3179	3111	3117	3123	4106	4108	4112	4113	4114	2172	4100	4104	4111	4115	6100	6101	6104	2101	4101	4103	4105	2115	2118	2124
J	OR	OR	OR	68R	68R	68R	68R	OR	OR	OR	OR	OR	15pF	OR	OR	OR	OR	PDZ-15P	PDZ-15P	PDZ-15P	220pF	OR	OR	OR	470uF	470uF	470uF
U, R, K, A, P	OR	OR	OR	OR	OR	OR	OR	OR	OR	OR	OR	OR	OR	OR	OR	OR	OR	OR	OR	OR	OR	OR	OR	OR	OR	OR	OR
B, G	-	-	-	68R	OR	OR	OR	OR	OR	OR	OR	OR	OR	OR	OR	OR	OR	OR	OR	OR	OR	OR	OR	OR	OR	OR	OR

SCHEMATIC DIAGRAM

FOR INFORMATION ONLY (NO SERVICE PARTS WILL BE AVAILABLE)

The first digit of a component indicates the component type.

- 1xxx : Connector 3xxx : Resistor 5xxx : Coil 7xxx : IC, Transistor, FET
- 2xxx : Capacitor 4xxx : SMD jumper 6xxx : Diode 9xxx : Wire jumper

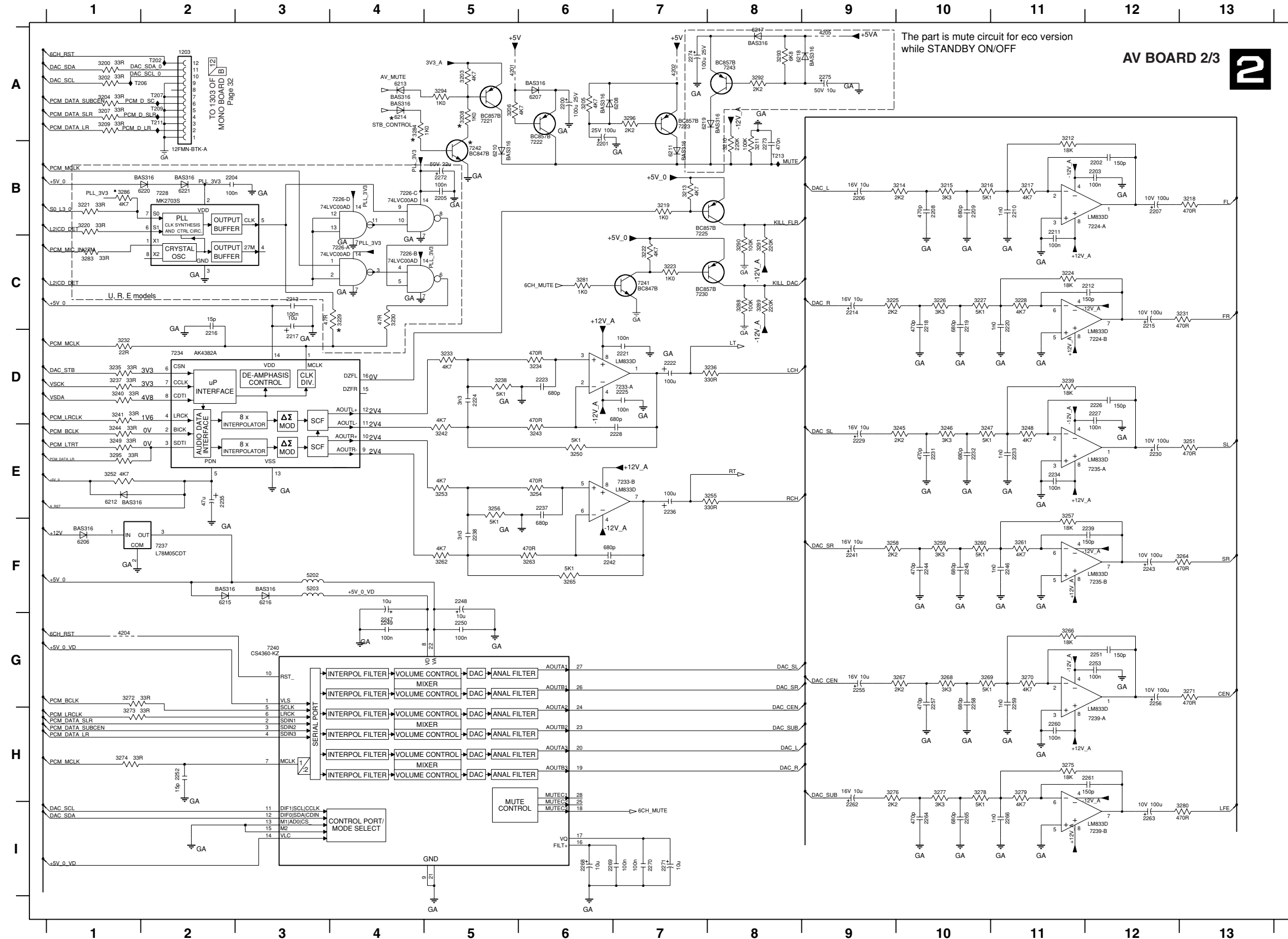

1203 A2	3239 D11
2200 A6	3240 D1
2201 B6	3241 D1
2202 B12	3242 E5
2203 B12	3243 E6
2204 B2	3244 E1
2205 B5	3245 E10
2206 B9	3246 E10
2207 B12	3247 E10
2208 B10	3248 E11
2209 B10	3249 E1
2210 B11	3250 E6
2211 B11	3251 E13
2212 C12	3252 E1
2213 C3	3253 E5
2214 C9	3254 E6
2215 C12	3255 E8
2216 D2	3256 E5
2217 D3	3257 E11
2218 C10	3258 F9
2219 C10	3259 F10
2220 F10	3260 F10
2221 D7	3261 F11
2222 D7	3262 F5
2223 D6	3263 F6
2224 D5	3264 F13
2225 D7	3265 F6
2226 D12	3266 G11
2227 D12	3267 G10
2228 E7	3268 G10
2229 E9	3269 G10
2230 E12	3270 G11
2231 E10	3271 G13
2232 E10	3272 G1
2233 E11	3273 H1
2234 H1	3274 H1
2235 E2	3275 H11
2236 E7	3276 H9
2237 E6	3277 H10
2238 F5	3278 H10
2239 F12	3279 H11
2241 F9	3280 H13
2242 F6	3281 C6
2243 F12	3283 C1
2244 F10	3284 A4
2245 F10	3286 B1
2246 F11	3288 C8
2247 G4	3289 C8
2248 F5	3290 C8
2249 G4	3291 C8
2250 G5	3292 A8
2251 G12	3293 A8
2252 H2	3294 A5
2253 G12	3295 E1
2255 G9	3296 A7
2256 G12	4201 A5
2257 G10	4202 A7
2258 G10	4204 G1
2259 G11	4205 A9
2260 H11	5202 F3
2261 H12	5203 F3
2262 I9	6206 F1
2263 I12	6207 A6
2264 I10	6208 A7
2265 I10	6210 B5
2266 I11	6211 B7
2268 I6	6212 E1
2269 I6	6213 A4
2270 I7	6214 A4
2271 I7	6215 F2
2272 B5	6216 F3
2273 B8	6217 A8
2274 A7	6218 A8
2275 A9	6219 A7
3200 A1	6220 B2
3202 A1	6221 B2
3203 A5	7221 A5
3204 A1	7222 A6
3205 A6	7223 A7
3206 A5	7224-A B12
3207 A1	7224-B D12
3208 A5	7225 B7
3209 A1	7226-A C4
3210 B8	7226-B C4
3211 B8	7226-C B4
3212 A11	7226-D B4
3213 B7	7228 B7
3214 B10	7230 C7
3215 B10	7233-A D7
3216 B10	7233-B E7
3217 B11	7234 D2
3218 B13	7235-A E12
3219 B7	7235-B F12
3220 B1	7237 F2
3221 B1	7238-A H12
3222 C7	7238-B H12
3223 C7	7240 G3
3224 C11	7241 C7
3225 C9	7242 B5
3226 C10	7243 A8
3227 C10	T202 A2
3228 C11	T206 A1
3229 C4	T207 A2
3230 C4	T209 A2
3231 C13	T211 A2
3232 D1	T213 B8
3233 D5	
3234 D6	
3235 D1	
3236 D8	
3237 D1	
3238 D5	

★ Components having special characteristics are marked Δ and must be replaced with parts having specifications equal to those originally installed.
 ★ Schematic diagram is subject to change without notice.

● Δ 印のある部品は、安全性確保部品を示しています。部品の交換が必要な場合、パーツリストに記載されている部品を使用してください。
 ● 本回路図は標準回路図です。改良のため予告なく変更することがございます。

SCHEMATIC DIAGRAM

FOR INFORMATION ONLY (NO SERVICE PARTS WILL BE AVAILABLE)

The first digit of a component indicates the component type.

- 1xxx : Connector 3xxx : Resistor 5xxx : Coil 7xxx : IC, Transistor, FET
- 2xxx : Capacitor 4xxx : SMD jumper 6xxx : Diode 9xxx : Wire jumper

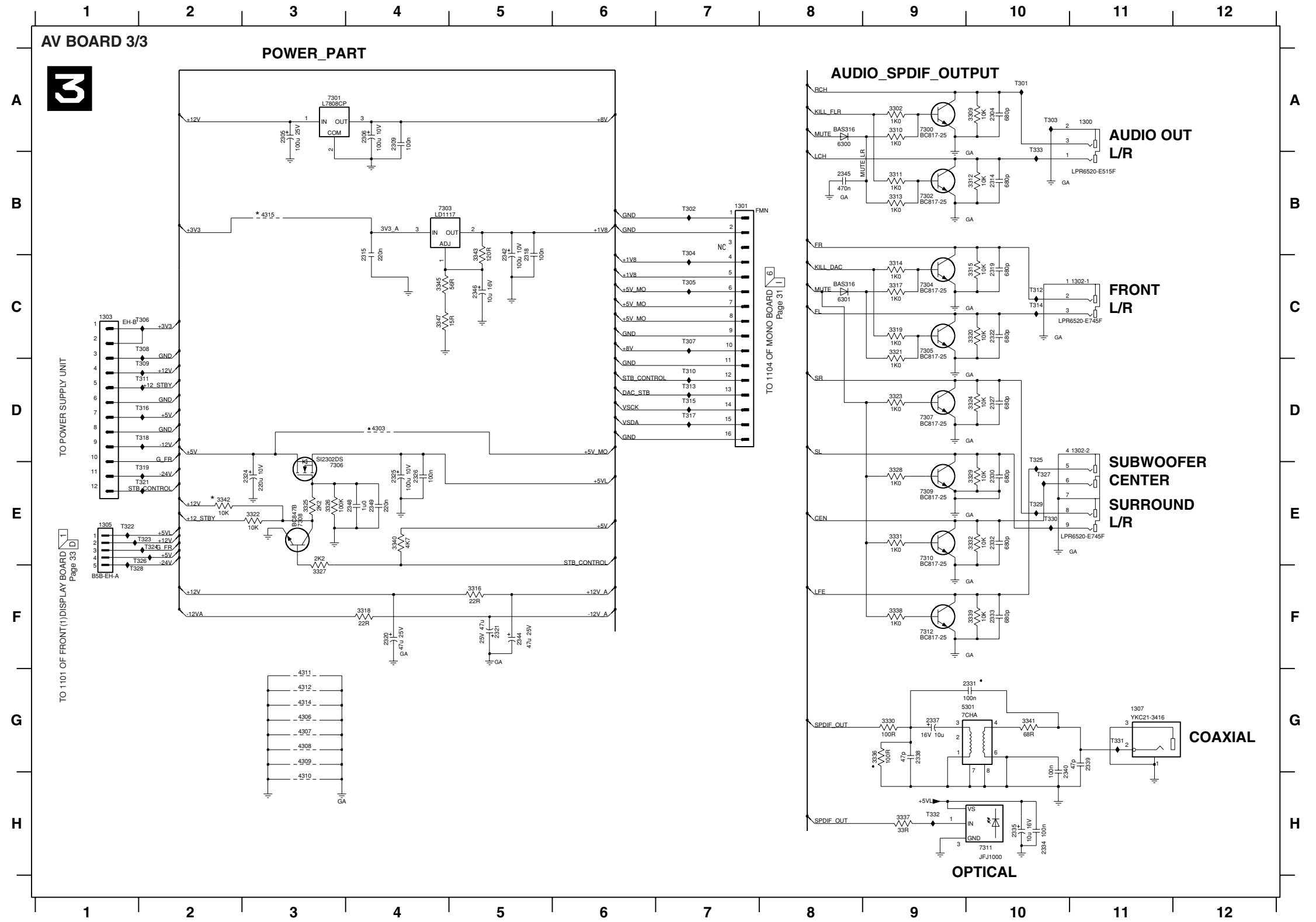

- 1300 A11
- 1301 B7
- 1302-1 C11
- 1302-2 D11
- 1303 C1
- 1305 E1
- 1307 G11
- 2304 A10
- 2305 A3
- 2306 A4
- 2309 A4
- 2314 B10
- 2315 B4
- 2318 B5
- 2319 C10
- 2320 F4
- 2321 F5
- 2322 C10
- 2324 E3
- 2325 E4
- 2326 E4
- 2327 D10
- 2330 E10
- 2331 G10
- 2332 E10
- 2333 F10
- 2334 H10
- 2335 H10
- 2337 G9
- 2338 G9
- 2339 G11
- 2340 G10
- 2342 B5
- 2344 F5
- 2345 B8
- 2346 C5
- 2348 E4
- 2349 E4
- 3002 A9
- 3009 A10
- 310 A9
- 311 B9
- 312 B10
- 313 B9
- 314 C9
- 315 C10
- 316 F5
- 317 C9
- 318 F4
- 319 C9
- 320 C10
- 321 C9
- 322 E3
- 323 D9
- 324 D10
- 325 E3
- 326 E3
- 327 F3
- 328 E9
- 329 E10
- 330 G9
- 331 E9
- 332 E10
- 336 G9
- 337 H9
- 338 F9
- 339 F10
- 340 E4
- 341 G10
- 342 E2
- 343 B5
- 344 C4
- 347 C4
- 4303 D4
- 4304 D5
- 4306 G3
- 4307 G3
- 4308 G3
- 4309 G3
- 4310 H3
- 4311 G3
- 4312 G3
- 4314 G3
- 4315 B3
- 5301 G9
- 6300 A8
- 6301 C8
- 7300 A9
- 7301 A3
- 7302 B9
- 7303 B4
- 7304 C9
- 7305 C9
- 7306 E3
- 7307 D9
- 7308 E3
- 7309 E9
- 7310 E9
- 7311 H10
- 7312 F9
- 7313 A10
- 7314 B7
- 7315 A10
- 7316 B7
- 7317 C7
- 7318 C2
- 7319 D7
- 7320 D7
- 7321 F5
- 7322 D7
- 7323 D2
- 7324 C10
- 7325 D7
- 7326 D7
- 7327 D10
- 7328 D7
- 7329 D2
- 7330 D2
- 7331 D7
- 7332 D2
- 7333 D2
- 7334 H10
- 7335 H10
- 7336 H10
- 7337 G9
- 7338 G9
- 7339 G11
- 7340 G10
- 7342 B5
- 7344 F5
- 7345 B8
- 7346 C5
- 7348 E4
- 7349 E4
- 7350 A9
- 7351 G11
- 7352 H9
- 7353 A10

★ Components having special characteristics are marked Δ and must be replaced with parts having specifications equal to those originally installed.
 ★ Schematic diagram is subject to change without notice.

● Δ 印のある部品は、安全性確保部品を示しています。部品の交換が必要な場合、パーツリストに記載されている部品を使用してください。
 ● 本回路図は標準回路図です。改良のため予告なく変更することがございます。

■ SCHEMATIC DIAGRAM

FOR INFORMATION ONLY (NO SERVICE PARTS WILL BE AVAILABLE)

The first digit of a component indicates the component type.

1xxx : Connector 3xxx : Resistor 5xxx : Coil 7xxx : IC, Transistor, FET
 2xxx : Capacitor 4xxx : SMD jumper 6xxx : Diode 9xxx : Wire jumper

1101 B1	2120 A9	4112 B5	F105 C1	F114 B8
1102 B9	3122 A7	4113 C5	F106 C1	F115 C8
2110 A6	3123 C7	6101 B7	F107 C1	F116 C8
2111 C6	3124 D7	6102 C7	F108 C1	F117 C8
2112 D6	3125 E4	6103 D7	F109 D1	F118 C9
2116 B7	3126 E5	F101 B1	F110 C2	
2117 C7	3127 E5	F102 B1	F111 A7	
2118 D7	4109 A8	F103 B1	F112 C7	
2119 A8	4111 A5	F104 B1	F113 D7	

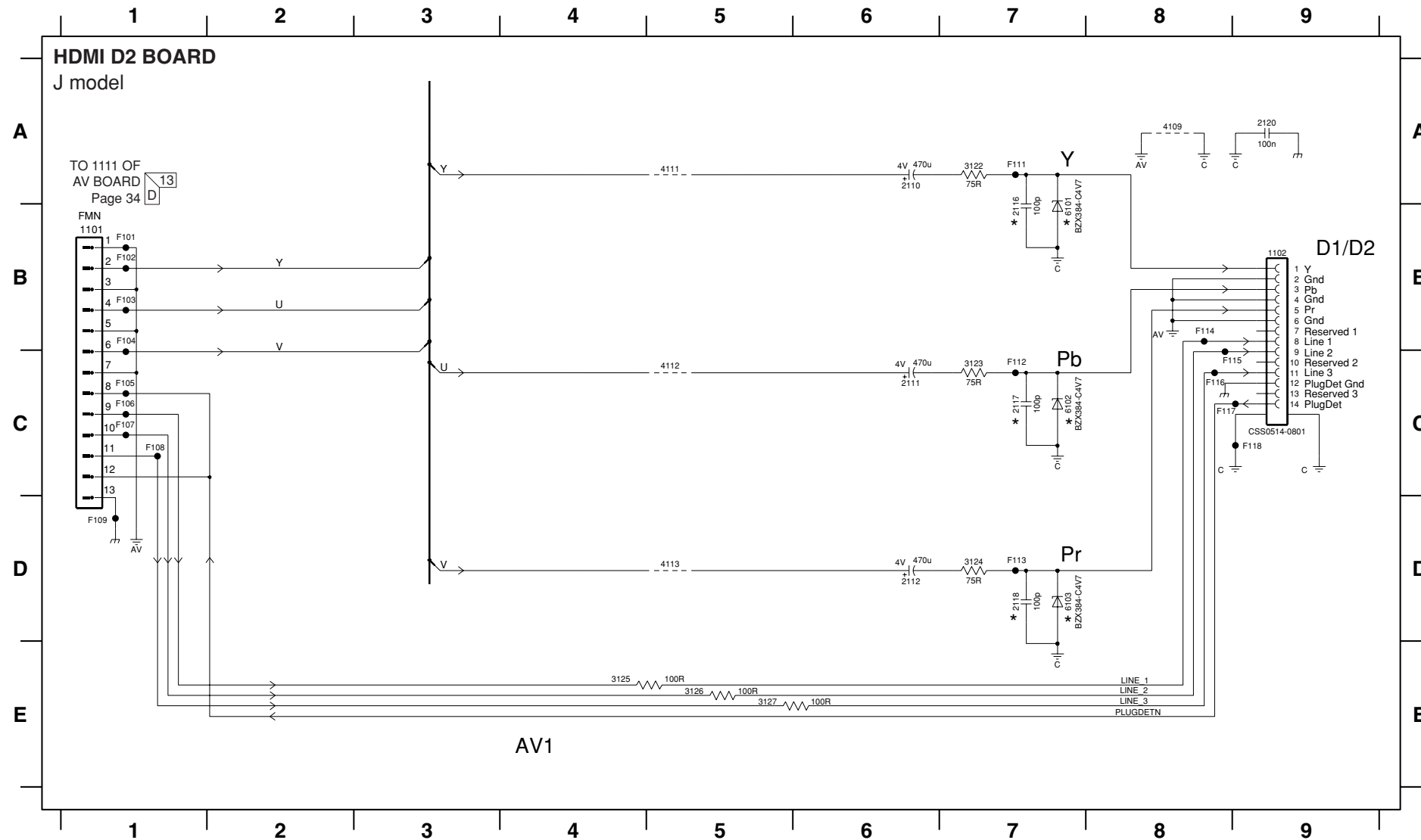

★ Components having special characteristics are marked with a star and must be replaced with parts having specifications equal to those originally installed.
 ★ Schematic diagram is subject to change without notice.

● 星印のある部品は、安全性確保部品を示しています。部品の交換が必要な場合、パーツリストに記載されている部品を使用してください。
 ● 本回路図は標準回路図です。改良のため予告なく変更することがございます。

EXPLODED VIEW

When disassembling, use the special screw driver with such tip shape as shown in figure.

T10 2.7 mm

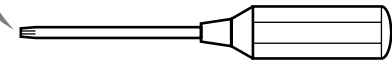

- 250 3 x 6 S-Tight with the brim
- 255 3 x 4 S-Tight Black
- 256 3 x 6 S-Tight Black
- 260 3 x 8 P-Tight Black

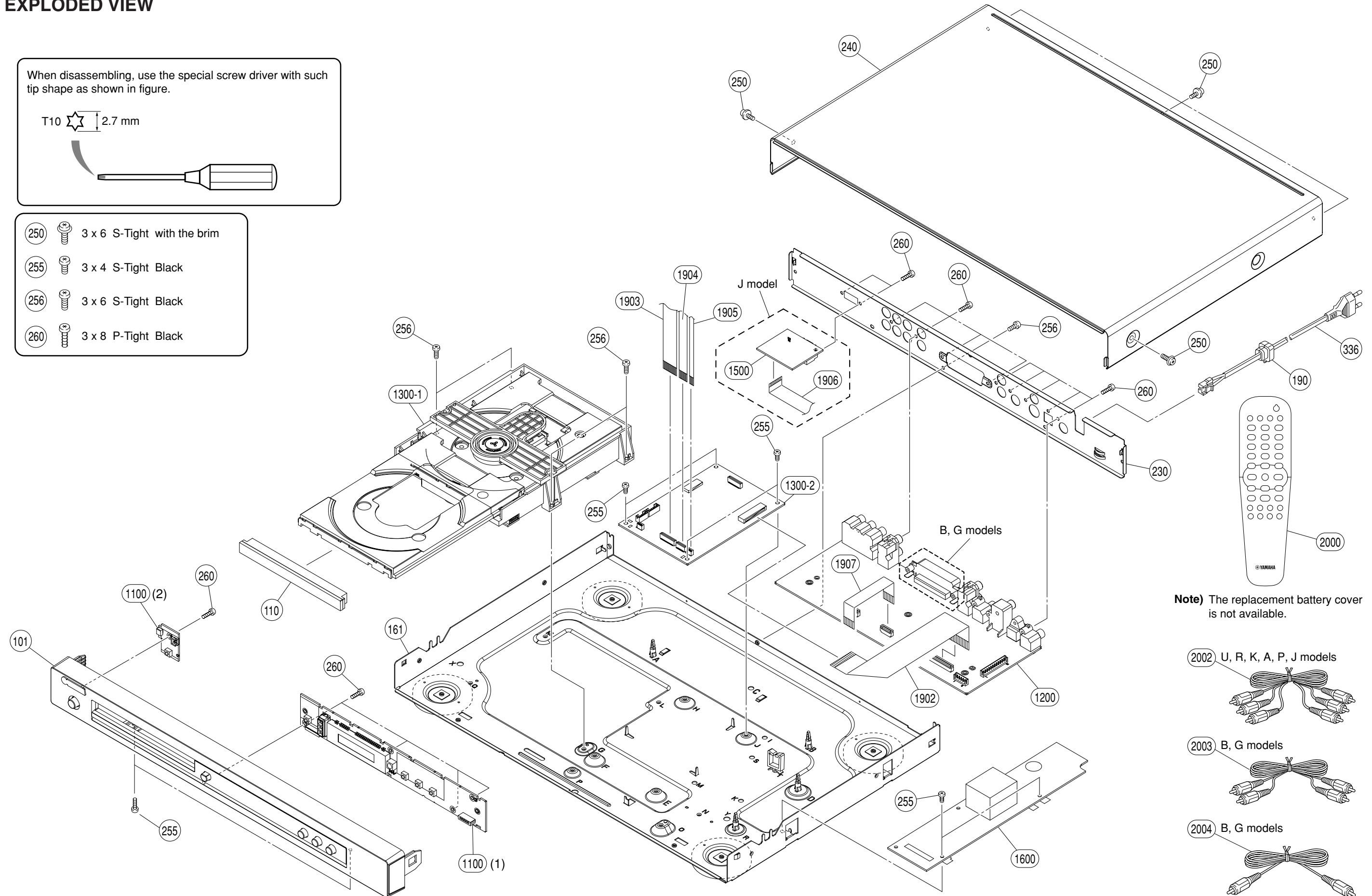

Note) The replacement battery cover is not available.

- 2002 U, R, K, A, P, J models
- 2003 B, G models
- 2004 B, G models

■ WARNING

- Components having special characteristics are marked △ and must be replaced with parts having specifications equal to those originally installed.
- △印のある部分は、安全確保部品を示しています。部品の交換が必要な場合、パーツリストに記載されている部品を使用してください。

■ MECHANICAL PARTS

Ref. No.	Part No.	Description	Remarks	Markets	部 品 名	Rank		
*	101	AAX69710	FRONT PANEL ASS'Y	S657GD	3141 079 32751	JRK	フロントパネルASSY	
*	101	AAX69700	FRONT PANEL ASS'Y	S657BL	3141 079 32741	UAP	フロントパネルASSY	
*	101	AAX69770	FRONT PANEL ASS'Y	S657BL	3143 027 62081	G	フロントパネルASSY	
*	101	AAX69760	FRONT PANEL ASS'Y	S657T1	3141 079 32941	U	フロントパネルASSY	
*	101	AAX69790	FRONT PANEL ASS'Y	S657T1	3143 027 62141	BG	フロントパネルASSY	
*	101	AAX69750	FRONT PANEL ASS'Y	S657S1	3141 079 32931	J	フロントパネルASSY	
*	101	AAX69740	FRONT PANEL ASS'Y	S657S1	3141 079 32921	R	フロントパネルASSY	
*	101	AAX69780	FRONT PANEL ASS'Y	S657S1	3143 027 62101	G	フロントパネルASSY	
*	101	AAX69720	FRONT PANEL ASS'Y	S5860BL	3141 079 32761	U	フロントパネルASSY	
*	101	AAX69730	FRONT PANEL ASS'Y	S5860S1	3141 079 32771	UA	フロントパネルASSY	
*	110	AAX69670	TRAY COVER ASS'Y	S657, S5860S1	3141 079 32781	JURKAP	トレイカバーASSY	
*	110	AAX69690	TRAY COVER ASS'Y	S657	3143 027 62091	BG	トレイカバーASSY	
*	110	AAX69680	TRAY COVER ASS'Y	S5860BL	3141 079 32811	U	トレイカバーASSY	
	161	AAX67050	FRAME ASS'Y	GD	3141 079 03091	JRK	フレームASSY	
	161	AAX67030	FRAME ASS'Y	BL, T1, S1	3141 079 02961	JURKAP	フレームASSY	
	161	AAX67060	FRAME ASS'Y	BL, T1, S1	3143 027 60891	BG	フレームASSY	
	190	AAX53540	BUSH	450H259010	3139 114 26671		ブッシュ	
*	230	AAX69830	REAR PANEL	S657	3139 241 22591	J	リアパネル	
*	230	AAX69860	REAR PANEL	S657	3139 241 22621	U	リアパネル	
*	230	AAX69820	REAR PANEL	S657	3139 241 22571	RK	リアパネル	
*	230	AAX69840	REAR PANEL	S657	3139 241 22601	A	リアパネル	
*	230	AAX69870	REAR PANEL	S657	3139 241 22631	BG	リアパネル	
*	230	AAX69850	REAR PANEL	S657	3139 241 22611	P	リアパネル	
*	230	AAX69810	REAR PANEL	S5860	3139 241 22561	U	リアパネル	
*	230	AAX69800	REAR PANEL	S5860	3139 241 22551	A	リアパネル	
	240	AAX59020	TOP COVER	GD	3139 241 22391		トップカバー	09
	240	AAX58270	TOP COVER	BL	3139 247 59051		トップカバー	
	240	AAX58290	TOP COVER	T1, S1	3139 241 22191		トップカバー	09
	250	AAX57730	PW HEAD TORX S-TIGHT SCREW	GD 3x6 MFN133	3103 301 45951		PWヘッドSタイトネジ	
	250	AAX55450	PW HEAD TORX S-TIGHT SCREW	BL 3x6 MFZN2BL	3139 110 40611		PWヘッドSタイトネジ	
	250	AAX53440	PW HEAD TORX S-TIGHT SCREW	T1, S1 3x6 MFN133	3104 120 40081		PWヘッドSタイトネジ	
	255	AAX55930	PAN HEAD TORX S-TIGHT SCREW	3x4 MFZN2BL	3141 010 40591		ナベトルクスSタイトネジ	
	256	AAX23640	PAN HEAD TORX S-TIGHT SCREW	3x6 MFZN2BL	2511 077 00039		ナベトルクスSタイトネジ	
	260	AAX53520	PAN HEAD TORX P-TIGHT SCREW	3x8 MFZN2BL	2511 076 50012		ナベトルクスPタイトネジ	
△	336	AAX53650	POWER CABLE	1.8m	2422 070 98255	J	電源コード	05
△	336	AAX47750	POWER CABLE	1.8m	2422 070 98235	U	電源コード	
△	336	AAX53630	POWER CABLE	1.8m	2422 070 98231	RGP	電源コード	
△	336	AAX59130	POWER CABLE	1.8m	2422 070 98222	K	電源コード	
△	336	AAX47740	POWER CABLE	1.8m	2422 070 98233	A	電源コード	
△	336	AAX58470	POWER CABLE	1.8m	3103 140 25882	B	電源コード	
*	1100	AAX69640	P.C.B. ASS'Y	FRONT	3139 248 85041		P C B フロント	
*	1200	AAX69610	P.C.B. ASS'Y	A/V	3139 248 84991	J	P C B A V	
*	1200	AAX69620	P.C.B. ASS'Y	A/V	3139 248 85001	URKAP	P C B A V	
*	1200	AAX69630	P.C.B. ASS'Y	A/V	3139 248 85011	BG	P C B A V	
*	1300-1	AAX70750	DVD MECHANISM	WXD8136 (012B)	3139 248 72251		D V D メカニズム	
*	1300-2	AAX70760	P.C.B. ASS'Y	MONO SD6.1 PL 6CH	3139 118 58082		D V D M O N O	
	1500	AAX57680	P.C.B. ASS'Y	HDMI D2 CONNECTOR	3139 248 82751	J	P C B H D M I	06
△	1600	AAX58480	POWER SUPPLY UNIT	HE 2004 MIT	3139 248 72062		電源ユニット	14
	1902	AAX58250	FLEXIBLE FLAT CABLE	30P 120mm P=1mm	3139 241 00541		カード電線 C & C	02
	1903	AAX58220	FLEXIBLE FLAT CABLE	16P 220mm P=1mm	3139 111 02421		カード電線 C & C	03
	1904	AAX58230	FLEXIBLE FLAT CABLE	9P 140mm P=1mm	3139 241 00521		カード電線 C & C	01
	1905	AAX58240	FLEXIBLE FLAT CABLE	4P 400mm P=1mm	3139 241 00531		カード電線 C & C	02
	1906	AAX64670	FLEXIBLE FLAT CABLE	13P 220mm P=1mm	3139 111 02411	J	カード電線 C & C	
*	1907	AAX69650	FLEXIBLE FLAT CABLE	12P 80mm P=1mm	3139 241 00511		カード電線 C & C	
			ACCESSORIES				付属品	
*	2000	AAX69880	REMOTE CONTROL	RC19237011/00H	3139 238 10511		リモコン	
	2002	AAX23450	AUDIO/VIDEO CABLE	YE/RD/WH 1.5m 1pc	2422 076 00304	JURKAP	音声/映像ピンケーブル	10
	2003	AAX21980	AUDIO PIN CABLE	RD/WH 1.5m 1pc	3103 308 92611	BG	ステレオピンケーブル	05
	2004	AAX22970	VIDEO PIN CABLE	YE 1.5m 1pc	3104 108 45432	BG	ビデオ用ピンケーブル	08
			BATTERY	UM-3 (2pcs)			乾電池 2 P C S	

* New Parts * 新規部品

DVD-S657/DV-S5860

