

DVD PLAYER

DVD-S663/DV-S6165

SERVICE MANUAL

IMPORTANT NOTICE

This manual has been provided for the use of authorized YAMAHA Retailers and their service personnel. It has been assumed that basic service procedures inherent to the industry, and more specifically YAMAHA Products, are already known and understood by the users, and have therefore not been restated.

WARNING: Failure to follow appropriate service and safety procedures when servicing this product may result in personal injury, destruction of expensive components, and failure of the product to perform as specified. For these reasons, we advise all YAMAHA product owners that any service required should be performed by an authorized YAMAHA Retailer or the appointed service representative.

IMPORTANT: The presentation or sale of this manual to any individual or firm does not constitute authorization, certification or recognition of any applicable technical capabilities, or establish a principle-agent relationship of any form.

The data provided is believed to be accurate and applicable to the unit(s) indicated on the cover. The research, engineering, and service departments of YAMAHA are continually striving to improve YAMAHA products. Modifications are, therefore, inevitable and specifications are subject to change without notice or obligation to retrofit. Should any discrepancy appear to exist, please contact the distributor's Service Division.

WARNING: Static discharges can destroy expensive components. Discharge any static electricity your body may have accumulated by grounding yourself to the ground buss in the unit (heavy gauge black wires connect to this buss).

IMPORTANT: Turn the unit OFF during disassembly and part replacement. Recheck all work before you apply power to the unit.

■ CONTENTS

TO SERVICE PERSONNEL	2-3	DISASSEMBLY PROCEDURES	13
PREVENTION OF ELECTROSTATIC DISCHARGE	4	分解手順	14
REGION MANAGEMENT INFORMATION	4	TEST MODE / テストモード	15
FRONT PANELS	5	BLOCK DIAGRAM	16
REAR PANELS	5-7	WIRING DIAGRAM	17
REMOTE CONTROL PANEL	7	PRINTED CIRCUIT BOARDS	18-25
SPECIFICATIONS / 参考仕様	8-9	SCHEMATIC DIAGRAMS	26-33
INTERNAL VIEW	10	REPLACEMENT PARTS LIST	34-35
REPAIR NOTES / 修理上の留意点	10	REMOTE CONTROL	36
TRADE MODE / トレードモード	11-12		



■ TO SERVICE PERSONNEL

1. Critical Components Information
Components having special characteristics are marked \triangle and must be replaced with parts having specifications equal to those originally installed.
2. Leakage Current Measurement (For 120V Models Only)
When service has been completed, it is imperative to verify that all exposed conductive surfaces are properly insulated from supply circuits.
 - Meter impedance should be equivalent to 1500 ohms shunted by 0.15 μ F.

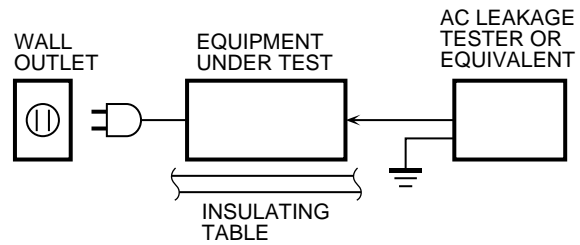

- Leakage current must not exceed 0.5mA.
- Be sure to test for leakage with the AC plug in both polarities.

WARNING: CHEMICAL CONTENT NOTICE!

This product contains chemicals known to the State of California to cause cancer, or birth defects or other reproductive harm. DO NOT PLACE SOLDER, ELECTRICAL/ELECTRONIC OR PLASTIC COMPONENTS IN YOUR MOUTH FOR ANY REASON WHAT SO EVER!

Avoid prolonged, unprotected contact between solder and your skin! When soldering, do not inhale solder fumes or expose eyes to solder/flux vapor!

If you come in contact with solder or components located inside the enclosure of this product, wash your hands before handling food.

WARNING: Laser Safety

This product contains a laser beam component. This component may emit invisible, as well as visible radiation, which may cause eye damage. To protect your eyes and skin from laser radiation, the following precautions must be used during servicing of the unit.

- 1) When testing and/or repairing any component within the product, keep your eyes and skin more than 30 cm/1 feet away from the laser pick-up unit at all times. Do not stare at the laser beam at any time.
- 2) Do not attempt to readjust, disassemble or repair the laser pick-up, unless noted elsewhere in this manual.
- 3) CAUTION: Use of controls, adjustments or performance of procedures other than those specified herein may result in hazardous radiation exposure.

Laser Emitting conditions:

- 1) When the Top Cover is removed, and the STANDBY/ON SW is turned to the "ON" position, the laser component will emit a beam for several seconds to detect if a disc is present. During this time (5-10 sec.) the laser may radiate through the lens of the laser pick-up unit. Do not attempt any servicing during this period!
If no disc is detected, the laser will stop emitting the beam. When a disc is loaded, you will not be exposed to any laser emissions.
- 2) The laser power level can be adjusted with the VR on the pick-up PWB, however, this level has been set by the factory prior to shipping from the factory. Do not adjust this laser level control unless instruction is provided elsewhere in this manual. Adjustment of this control can increase the laser emission level from the device.

警告：レーザーの安全対策

本機はレーザー光線を放射する部品を搭載しています。この部品が放射するレーザー光線は目に損傷を起こします。このレーザー光線から目及び肌を保護するために、本機の修理作業中は下記の注意を厳守してください。

- 1) テスト時または修理時、目及び肌を光ピックアップから30cm以上離してください。いかなる場合もレーザー光線を見つめないでください。
- 2) 光ピックアップの再調整及び分解はしないでください。
- 3) このマニュアル上で指定されている以外の制御、調整、手順はレーザー光線を照射される結果を招く恐れがあります。

レーザー放射条件

- 1) トップカバーを取り外しSTANDBY/ONスイッチをONにすると、ディスク検知のため5～10秒間、光ピックアップからレーザー光線が放射されます。この間、修理はしないでください。
ディスクが検知されなければ、レーザー光線の放射は停止します。ディスクがセットされている場合、ディスクで遮られるのでレーザー光線は修理担当者には届きません。
- 2) レーザーパワーレベルは光ピックアップ基板上のVRにより調整可能ですが、工場出荷前に調整セット済みなので、このVRは廻さないでください。このVRを廻すと装置からのレーザー光線の放射レベルが上がる恐れがあります。

Laser Diode Properties

Type:	Semiconductor laser GaAs/GaAlAs
Wave length:	650 nm (DVD) 780 nm (VCD/CD)
Output Power:	7 mW (DVD) 10 mW (VCD/CD)
Beam divergence:	60 degree

レーザー

タイプ:	半導体レーザーGaAs/GaAlAs
波長:	650 nm (DVD) 780 nm (VCD/CD)
出力:	7 mW (DVD) 10 mW (VCD/CD)
ビーム広がり:	60度

WARNING

The use of optical instruments with this product will increase eye hazard.
Repair handling should take place with a disc loaded inside the player as much as possible.

CAUTION

VISIBLE AND INVISIBLE LASER RADIATION WHEN OPEN. AVOID EXPOSURE TO BEAM.

ADVARSEL

SYNLIG OG USYNLIG LASERSTRÅLING VED ÅBNING. UNDGÅ UDSÆTTELSE FOR STRÅLING.

ADVARSEL

SYNLIG OG USYNLIG LASERSTRÅLING NÅR DEKSEL ÅPNES. UNNGÅ EKSPONERING FOR STRÅLEN.

VARNING

SYNLIG OCH OSYNLIG LASERSTRÅLNING NÄR DENNA DEL ÄR ÖPPNAD. BETRAKTA EJ STRÅLEN.

VARO!

AVATTAESSA OLET ALTTIINA NÄKYVÄLLE JA NÄKYMÄTTÖMÄLLE LASER SÄ TEILYLLE. ÄLÄ KATSO SÄTEESEEN.

VORSICHT

SICHTBARE UND UNSICHTBARE LASERSTRAHLUNG WENN ABDECKUNG GEÖFFNET. NICHT DEM STRAHL AUSSETZEN.

DANGER

VISIBLE AND INVISIBLE LASER RADIATION WHEN OPEN. AVOID DIRECT EXPOSURE TO BEAM.

ATTENTION

RAYONNEMENT LASER VISIBLE ET INVISIBLE EN CAS D'OUVERTURE. EXPOSITION DANGEREUSE AU FAISCEAU.

OSTRZEŻENIE

WIDZIALNE I NIEWIDZIALNE PROMIENIOWANIE LASEROWE PO OTWARCIU. UNIKAĆ NARAŻENIA NA WIĄZKĘ LASEROWĄ.

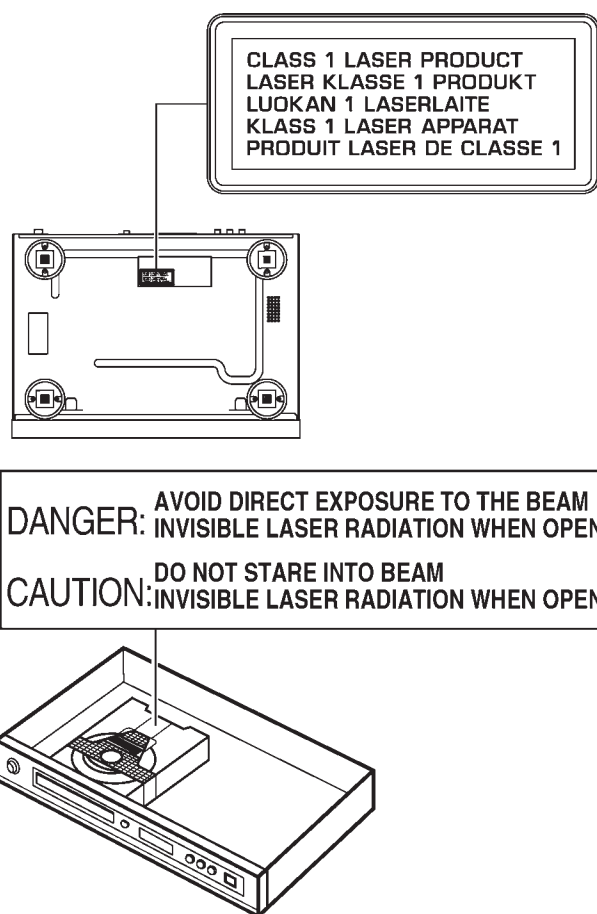

Warning for power supply

The primary side of the power supply carries live mains voltage when the player is connected to the mains even when the player is switched off !

This primary area is not shielded so it is possible to accidentally touch copper tracks and/or components when servicing the player.

Service personnel have to take precautions to prevent touching this area or components in this area.

Note:

The screws on the DVD mechanism may never be touched, removed or re-adjusted.

Handle the DVD mechanism with care when the unit has to be exchanged!

The DVD mechanism is very sensitive against dropping or shocks.

■ PREVENTION OF ELECTROSTATIC DISCHARGE

The laser diode in the DVD mechanism may be damaged due to static electricity from clothes or the human body. Use caution to prevent electrostatic damage when servicing or handling the DVD-mechanism.

1. Grounding for electrostatic damage prevention

Some devices, such as the DVD player, use an optical pickup (laser diode) that will be damaged by static electricity in the working environment. Only attempt service after ensuring that all grounding procedures have been completed.

1. Worktable grounding

Put a grounded conductive material (sheet) or iron sheet on the area where the optical pickup is placed.

2. Human body grounding

Use an anti-static wrist strap to discharge the static electricity from your body.

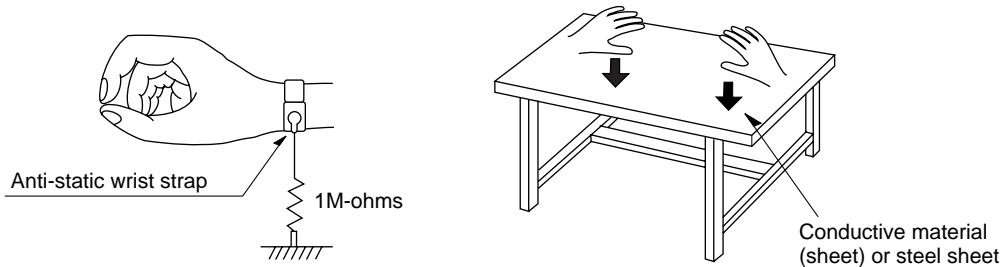

2. Handling Precautions for DVD mechanism

1. Handle the DVD mechanism gently, as it is an extremely high-precision assembly.
2. The flexible cable lines may break if an excessive force is applied to it. Use caution when handling the cable.
3. The semi-fixed resistor for laser power adjustment should not be adjusted. Do not turn the resistor.

■ REGION MANAGEMENT INFORMATION

Region Management Information: This DVD player is designed and manufactured to respond to the Region Management Information that is recorded on a DVD disc. If the Region number described on the DVD disc does not correspond to the Region number of this DVD player, this DVD player cannot play this disc.

This product incorporates copyright protection technology that is protected by method claims of certain U.S. patents and other intellectual property rights owned by Macrovision Corporation and other rights owners. Use of this copyright protection technology must be authorized by Macrovision Corporation, and is intended for home and other limited viewing uses only unless otherwise authorized by Macrovision Corporation. Reverse engineering or disassembly is prohibited.

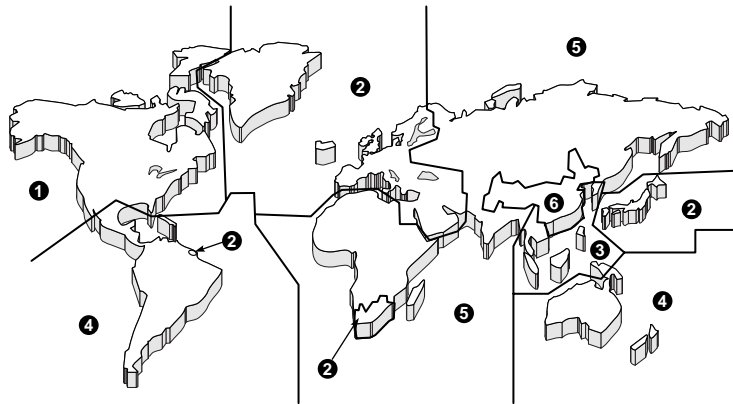

FRONT PANELS

DVD-S663 (U, K, A, G, F, L, P, J models)

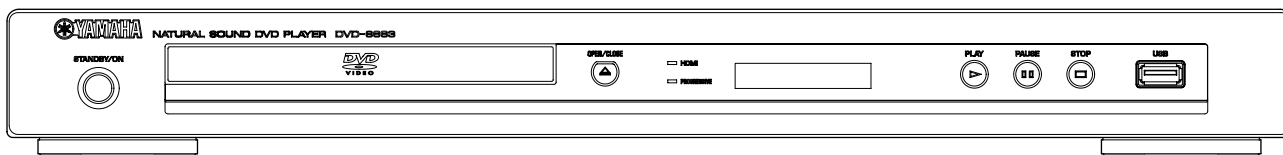
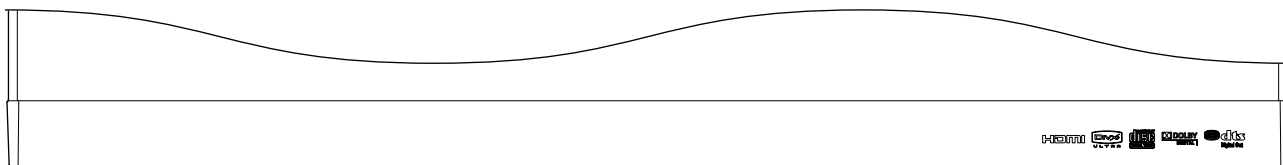

DV-S6165 (U model)

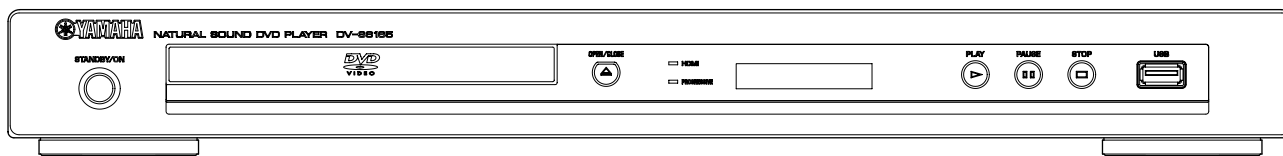
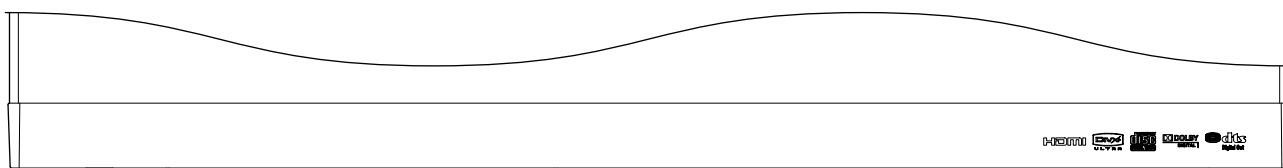

REAR PANELS

DVD-S663 (U model)

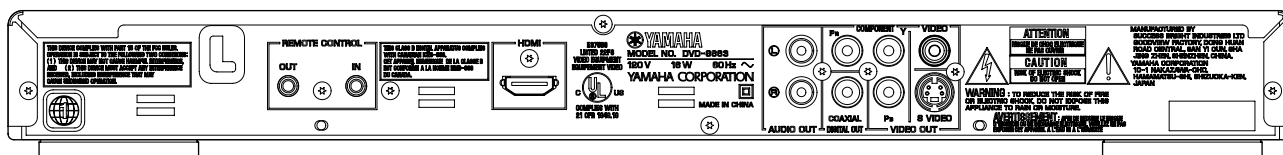

DVD-S663 (K model)

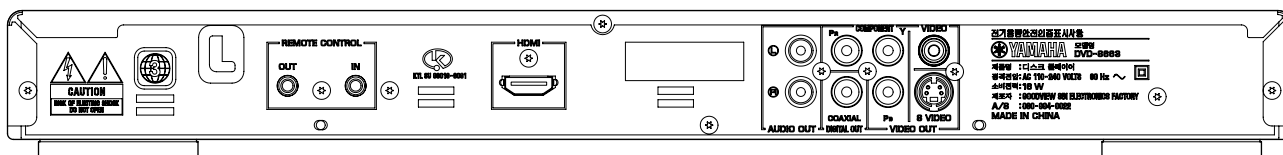

DVD-S663 (A model)

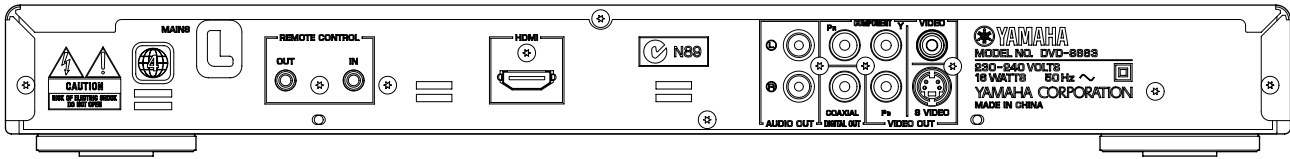

DVD-S663 (G model)

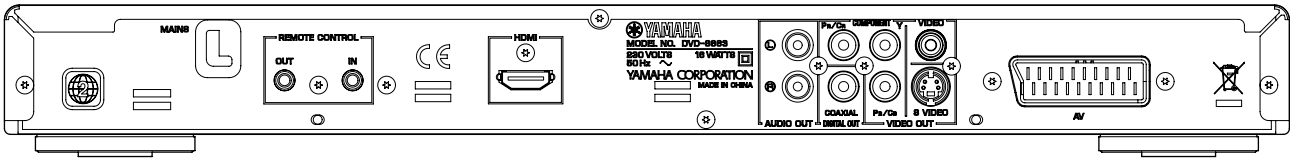

DVD-S663 (F model)

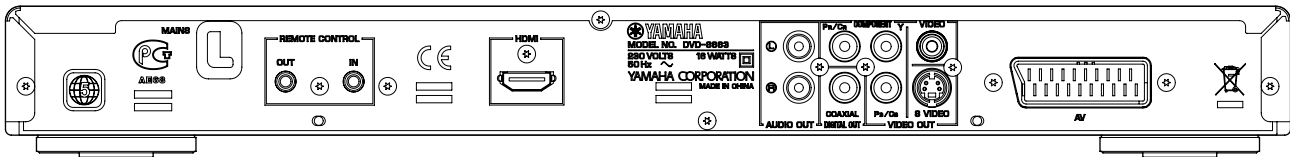

DVD-S663 (L model)

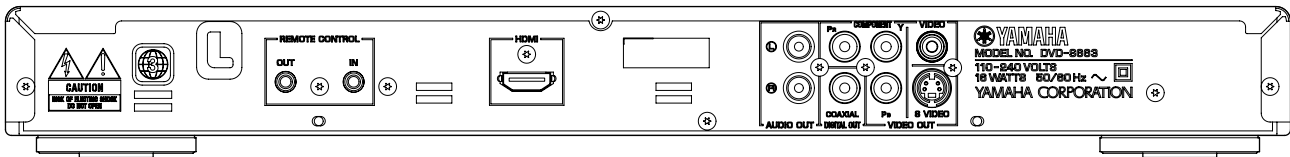

DVD-S663 (P model)

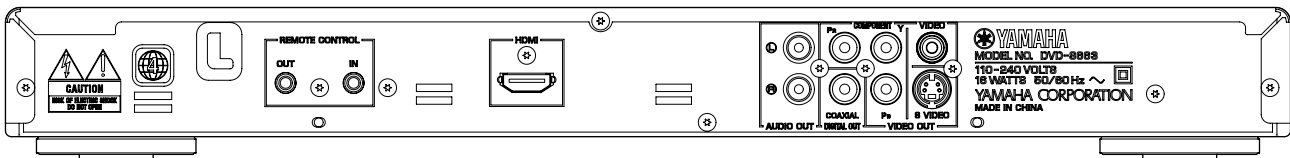

DVD-S663 (J model)

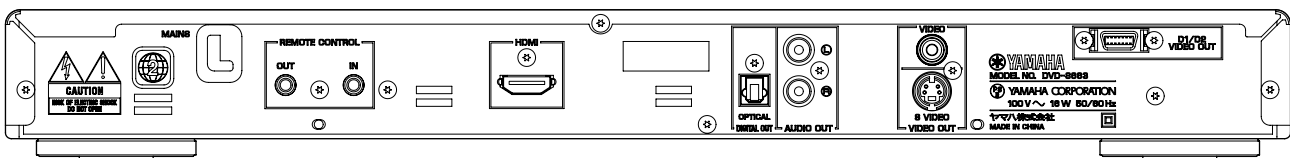

DV-S6165 (U model)

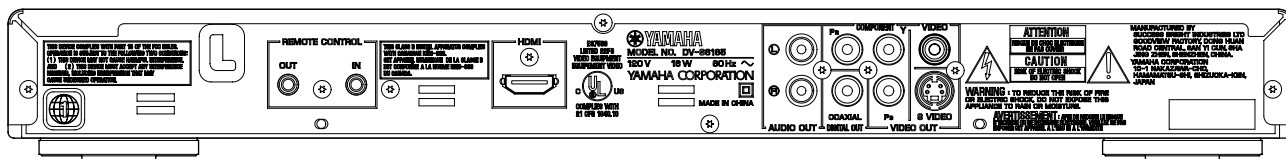

DVD-S663/DV-S6165

■ REMOTE CONTROL PANEL

DVD-16

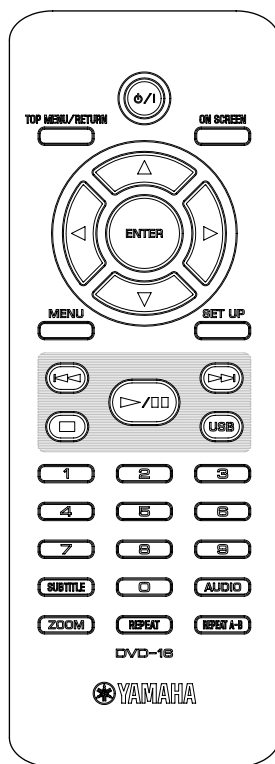

■ SPECIFICATIONS / 参考仕様

PLAYBACK SYSTEM / 対応ディスク

DVD Video	
DVD-R, DVD-RW, DVD-R DL	
DVD+R, DVD+RW, DVD+R DL	
Video CD, SVCD	
CD	
PICTURE CD	
CD-R, CD-RW	
MP3 (ISO 9660)	fs 32, 44.1, 48 kHz / 96 to 320 kbps
WMA	fs 44.1 kHz / 64 to 192 kbps fs 48 kHz / 128 to 192 kbps
WMV	720 x 480 / 720 x 576 dpi or less
DivX®	
JPEG	3072 x 2048 pixels or less

VIDEO PERFORMANCE / ビデオ部

Video (CVBS) output	1 Vpp into 75 ohms
S-Video output	Y: 1 Vpp into 75 ohms C: 0.3 Vpp into 75 ohms
Component video output (U, K, A, G, F, L, P models)	
Y	1 Vpp into 75 ohms
PB/CB (PB), PR/CR (PR)	0.7 Vpp into 75 ohms
RGB (SCART) output (G, F models)	Y: 0.7 Vpp into 75 ohms
D1/D2 (J model)	Y: 1 Vpp into 75 ohms PB, PR: 0.7 Vpp into 75 ohms

AUDIO FORMAT / オーディオフォーマット

Digital	
Dolby Digital, DTS	Compressed digital
PCM	fs 44.1, 48, 96 kHz / 16, 20, 24 bits
Analog sound	Stereo

AUDIO PERFORMANCE / オーディオ特性

DA converter	24 bits
Signal to noise (1 kHz)	105 dB
Dynamic range (1 kHz)	97 dB
DVD	fs 96 kHz 2 Hz to 44 kHz fs 48 kHz 2 Hz to 22 kHz
SVCD	fs 48 kHz 2 Hz to 22 kHz fs 44.1 kHz 2 Hz to 20 kHz
CD/VCD	fs 44.1 kHz 2 Hz to 20 kHz
Distortion and noise (1 kHz)	0.0035 %

MULTIMEDIA (USB) APPLICATIONS /

マルチメディアアプリケーション

Connections	USB mass storage class device
Playback formats (USB device)	
MP3	fs 32, 44.1, 48 kHz / 96 to 320 kbps
WMA	fs 44.1 kHz / 64 to 192 kbps fs 48 kHz / 128 to 192 kbps
WMV	720 x 480 / 720 x 576 dpi or less
DivX®	
JPEG	3072 x 2048 pixels or less

TV STANDARD (PAL/50 Hz) (NTSC/60 Hz)

Number of lines	625	525
Playback	Multistandard	(PAL/NTSC)

CONNECTIONS / 接続端子

Video output	RCA/Phono x 1 (yellow)
S-video output	Mini DIN, 4 pins x 1
Component video output (U, K, A, G, F, L, P models)	
Y output	RCA/Phono x 1 (green)
PB/CB (PB) output	RCA/Phono x 1 (blue)
PR/CR (PR) output	RCA/Phono x 1 (red)
SCART (G, F models)	Euroconnector x 1
Audio output (L+R)	RCA/Phono x 1 pair (white/red)
Digital output	
Coaxial (U, K, A, G, F, L, P models)	RCA/Phono x 1 IEC60958 for CDDA/LPCM / IEC61937 for Dolby Digital and DTS x 1
Optical (J model)	IEC60958 for CDDA/LPCM / IEC61937 for Dolby Digital and DTS x 1
HDMI	Type A x 1
USB	Type A x 1
Remote control	
Input	ø3.5 mm mini jack x 1
Output	ø3.5 mm mini jack x 1

GENERAL / 一般

Dimensions (W x H x D)	435 x 51 x 318 mm
寸法(幅×高さ×奥行き)	(17-1/8" x 2" x 12-1/2")
Weight / 質量	Approx. 2.6 Kg (5 lbs. 12 oz)
Finish / 仕上げ	
[DVD-S663]	Gold color (J model) Black color (U, A, G, F, P models) Titanium color (G, F, K, L models) Silver color (G, F models)
[DV-S6165]	Black color (U model)
Power Supply / 電源電圧	AC120V, 60 Hz (U model) AC110-240V, 60 Hz (K model) AC230-240V, 50 Hz (A model) AC230V, 50 Hz (G, F models) AC110-240V, 50/60 Hz (L, P models) AC100V, 50/60 Hz (J model)
Power consumption / 消費電力	Approx. 16 W
Standby power consumption / 待機時消費電力	Less than 1 W

ACCESSORIES / 付属品

Remote control x 1
Battery (R03, AAA, UM-4) x 2
Audio/Video cable (1.5 m) x 1 (U, K, A, L, P, J models)
Audio pin cable (1.5 m) x 1 (G, F models)
Video pin cable (1.5 m) x 1 (G, F models)

* **Specifications are subject to change without prior notice.**
※ 参考仕様および外観は予告なく変更されることがあります。

U U.S.A and Canada models	F Russian model
K Korean model	L Singapore model
A Australian model	P South American model
G European model	J Japanese model



Manufactured under license from Dolby Laboratories. Dolby and the double-D symbol are trademarks of Dolby Laboratories.

ドルビーラボラトリーズからの実施権に基づき製造されています。Dolby、ドルビー及びダブルD記号はドルビーラボラトリーズの商標です。



DTS and DTS Digital Out are registered trademarks and the DTS logos and Symbol are trademarks of DTS, Inc.

DTS、およびDTS Digital OutはDTS社の登録商標です。また、DTSロゴ、および記号はDTS社の商標です。



DivX, DivX Ultra Certified, and associated logos are trademarks of DivX, Inc. and are used under license.



DivX, DivX Ultra Certified、および関連するロゴは、DivX, Inc.の商標です。これらの商標は、DivX, Inc.の使用許諾を得て使用しています。



HDMI, the HDMI logo and High-Definition Multimedia Interface are trademarks or registered trademarks of HDMI Licensing LLC.

HDMI、HDMIロゴ、およびHigh-Definition Multimedia Interfaceは、HDMI Licensing, LLCの商標または登録商標です。

This product incorporates copyright protection technology that is protected by U.S. patents and other intellectual property rights. Use of this copyright protection technology must be authorized by Macrovision, and is intended for home and other limited viewing uses only unless otherwise authorized by Macrovision. Reverse engineering or disassembly is prohibited.

本製品は、著作権保護技術を採用しており、米国特許及びその他の知的財産権によって保護されています。この著作権保護技術の使用は、マクロビジョンの許可が必要で、またマクロビジョンの特別な許可がない限り家庭用及びその他の一部の視聴用の使用に制限されています。分解したり、改造することも禁じられています。

• DIMENSIONS / 寸法図

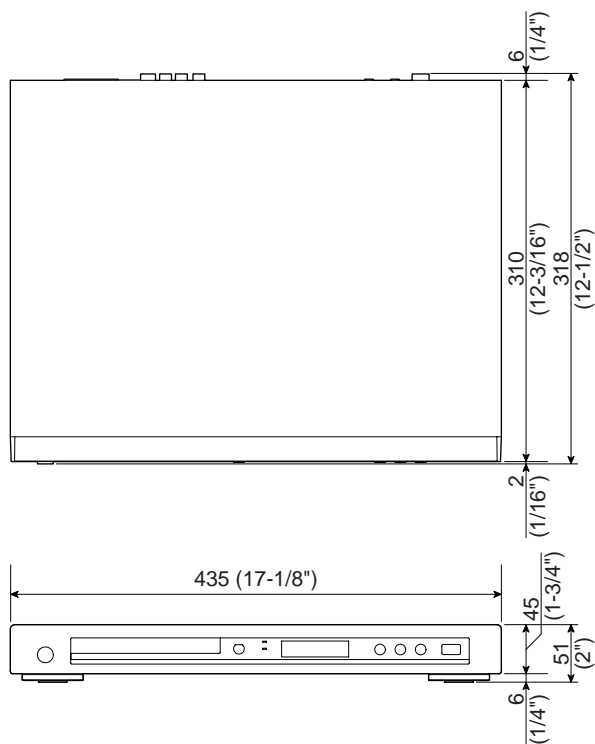

Unit: mm (inch)
単位: mm(インチ)

INTERNAL VIEW

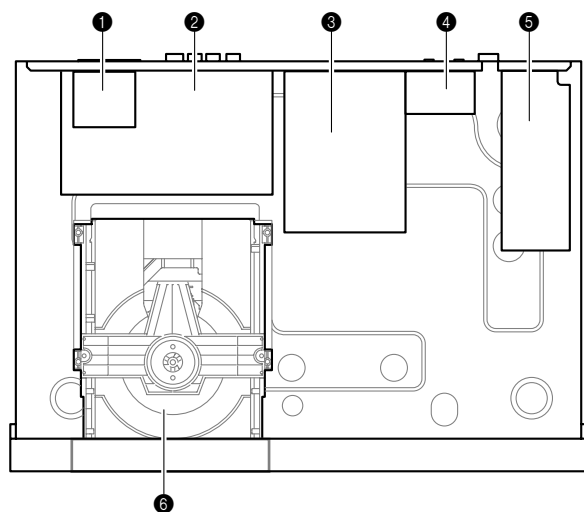

- ① D2 P.C.B. (J model)
- ② AV P.C.B.
- ③ MPEG P.C.B.
- ④ FRONT (3) P.C.B.
- ⑤ Power Supply Unit
- ⑥ Loader Ass'y

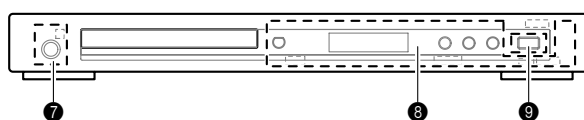

- ⑦ FRONT (2) P.C.B.
- ⑧ FRONT (1) P.C.B.
- ⑨ USB Connector

REPAIR NOTES / 修理上の留意点

None of the components of the following units can be supplied separately.

Each unit must be replaced as a whole in case of a failure.

- Loader Ass'y
- MPEG P.C.B.
- FRONT P.C.B.
- AV P.C.B.
- Power Supply Unit

下記のユニットは、小部品の部品供給はできません。
故障の場合は、各ユニットを交換してください。

- ローダーASSY
- MPEG P.C.B.
- FRONT P.C.B.
- AV P.C.B.
- D2 P.C.B. (J model)
- 電源ユニット

■ TRADE MODE / トレードモード

This unit provides TRADE mode which prevents the disc tray from opening even when the "OPEN/CLOSE" key is pressed.

• Activating TRADE mode

The power to this unit should be turned on before activating the TRADE mode.

1. Press the "OPEN/CLOSE" key to open the disc tray. (Fig. 1)
2. Press the "2", "5" and "9" keys on the remote control in that order. (Fig. 2)
3. "TRA ON" is displayed and TRADE mode is activated. About 2 seconds later, the disc tray is closed automatically. (Fig. 3)

Notes)

- After activating TRADE mode, it is not possible to operate keys of this unit as usual except the following key.
"STANDBY/ON" key (Turn on the power only)
But operation with the remote control is available as usual.
- After TRADE mode is activated, initial settings for repeat reproduction of this unit are as follows.
DVD : RPT TT (repeat title)
VCD/SVCD/CD : RPT ALL (repeat all)

本機には、“OPEN/CLOSE”キーを押した時ディスクトレイが開くのを防ぐトレードモードがあります。

• トレードモードの起動

トレードモードを起動する前に、本機の電源を入れます。

1. 本機の“OPEN/CLOSE”キーを押し、ディスクトレイを開けます。(Fig. 1)
2. リモコンの“2”、“5”、“9”のキーを押します。(Fig. 2)
3. “TRA ON”が表示され、トレードモードが起動します。約2秒後、ディスクトレイが自動的に閉じます。(Fig. 3)

注意)

- トレードモードを起動した後、以下のキー以外は操作できません。
“STANDBY/ON”キー(電源を入れるのみ)
リモコンによる操作は可能です。
- トレードモードを起動した後、再生の初期設定は以下の通りです。
DVD : RPT TT(タイトルリピート)
VCD/SVCD/CD : RPT ALL(オールリピート)

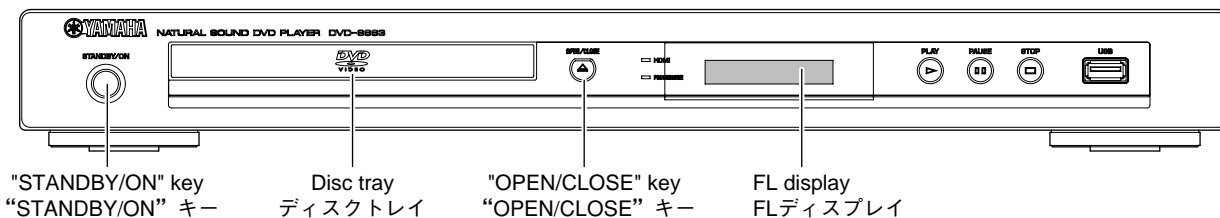

Fig. 1

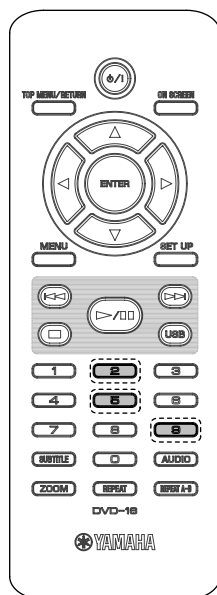
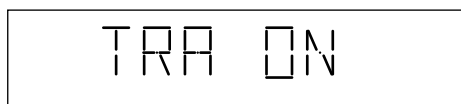

Fig. 2

TRADE mode display / トレードモード表示



Enter / 起動

Fig. 3

• Canceling TRADE mode

The power to this unit should be turned on before canceling TRADE mode.

1. Press and hold the “STOP” key on the remote control. (Fig. 4)
The disc tray opens after about 2 second.
2. Press the “2”, “5” and “9” keys on the remote control in that order. (Fig. 4)
3. “TRA OFF” is displayed and TRADE mode is cancelled. About 2 seconds later, the disc tray is closed automatically. (Fig. 5)

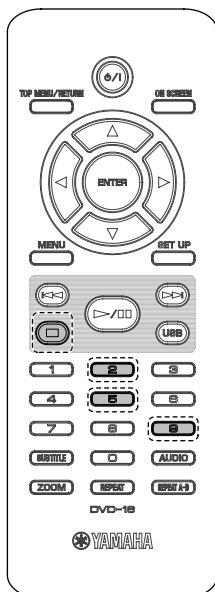
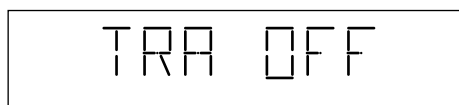

Fig. 4

• トレードモードの解除

トレードモードを解除する前に、本機の電源を入れます。

1. リモコンの“STOP”キーを押し続けます。(Fig. 4)
約2秒後、ディスクトレイが開きます。
2. リモコンの“2”、“5”、“9”のキーを押します。
(Fig. 4)
3. “TRA OFF”が表示され、トレードモードが解除されます。約2秒後、ディスクトレイが自動的に閉じます。(Fig. 5)



Cancel / 解除

Fig. 5

DISASSEMBLY PROCEDURES

See REPLACEMENT PARTS LIST for item numbers.

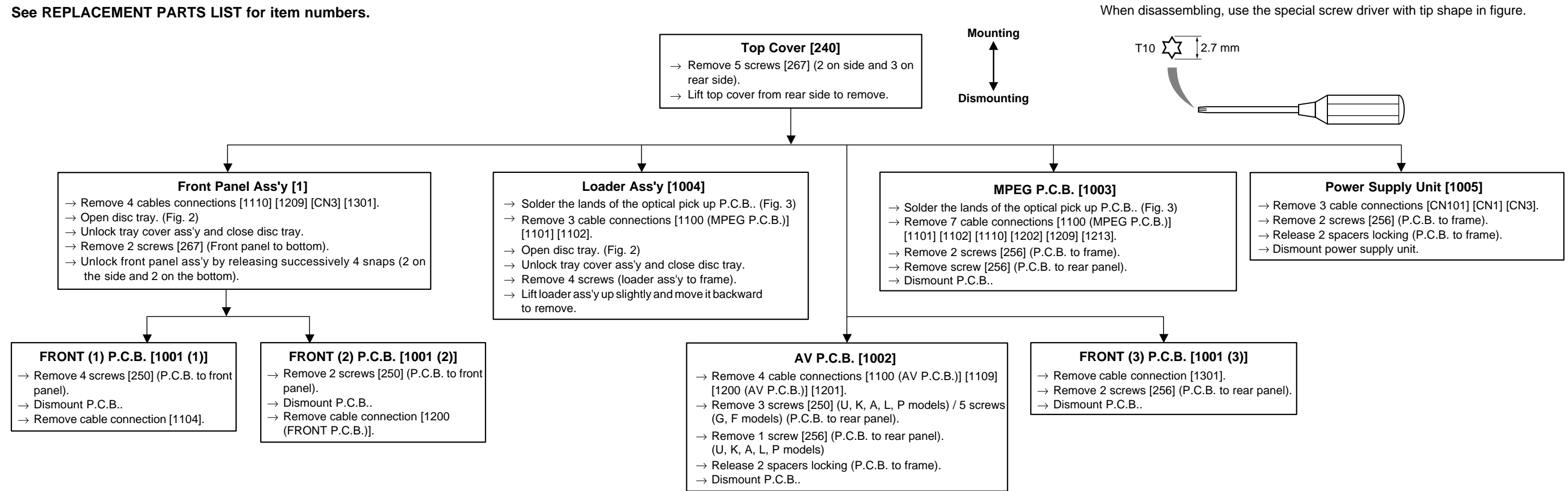

● Cable connections

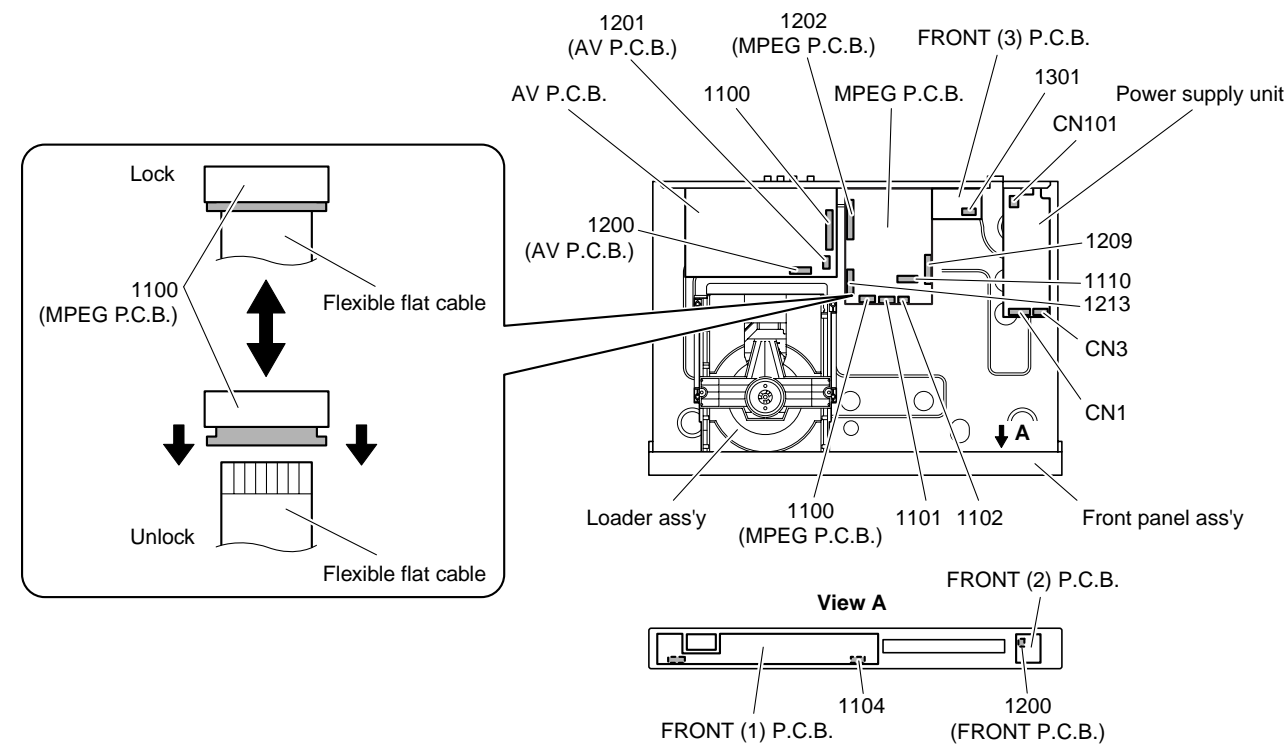

Fig. 1

● How to manually eject the disc tray

- Move the slider in the direction indicated with a screwdriver until the disc tray is ejected.
- Gently pull the disc tray out.

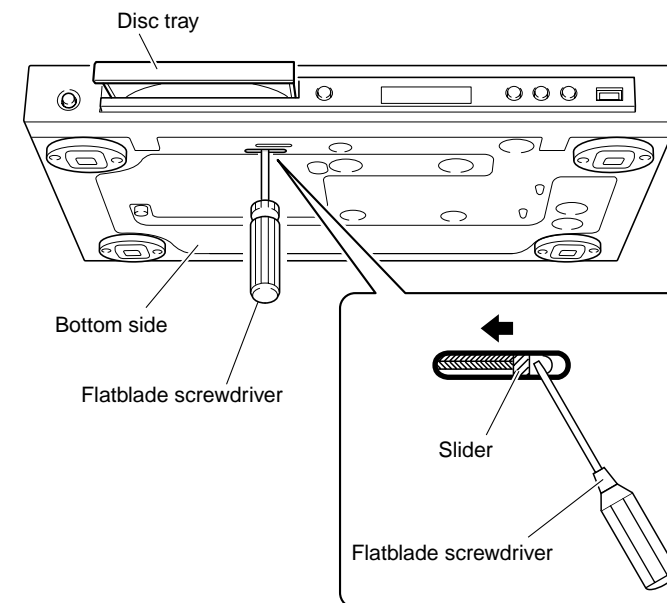

Fig. 2

● Preventive measure for optical pick up from electrostatic breakdown

When replacing the MPEG P.C.B. or loader ass'y, solder between lands of the optical pick up P.C.B. to protect the laser diode against electrostatic breakdown.

Notes

- Use an anti-static soldering iron to short-circuit and unshort-circuit optical pick up P.C.B..
- After you have finished repairing, remove the solder from the short-circuit location.

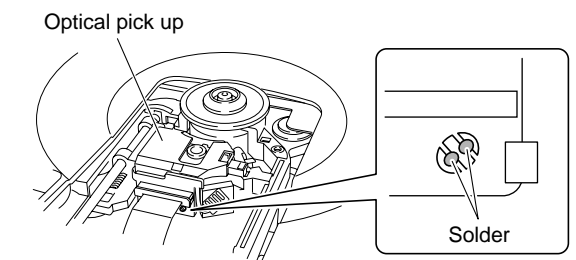
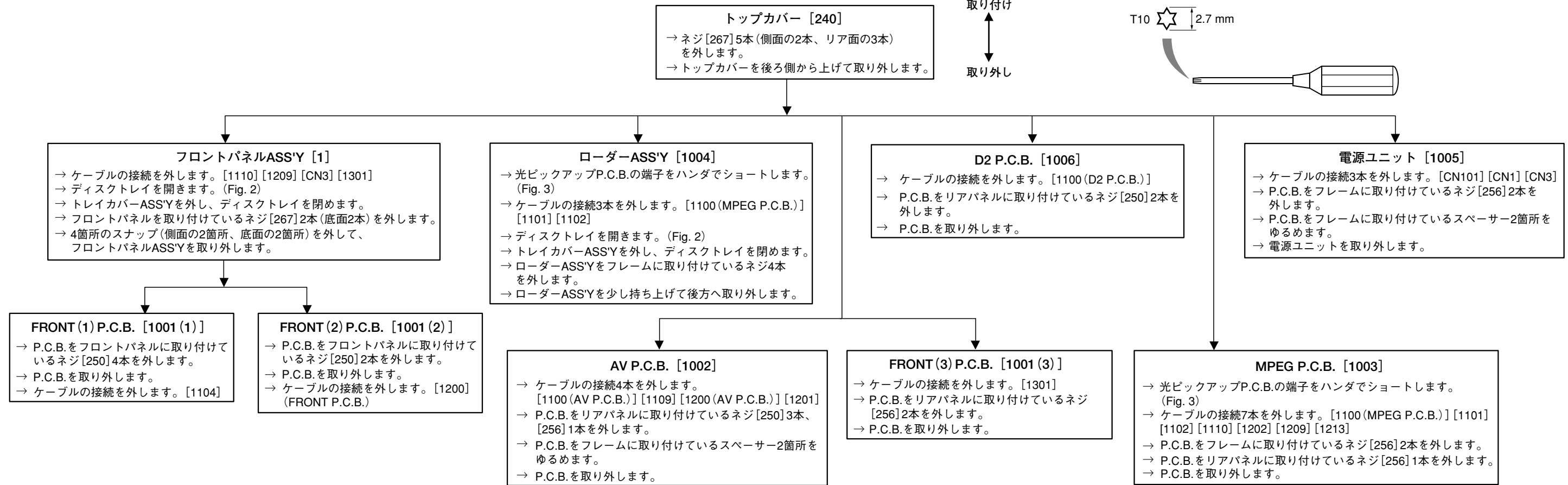

Fig. 3

■ 分解手順

項目番号についてはパーツリストを参照してください。

分解には図のような特殊ドライバーを使用します。



● コネクタ配置図

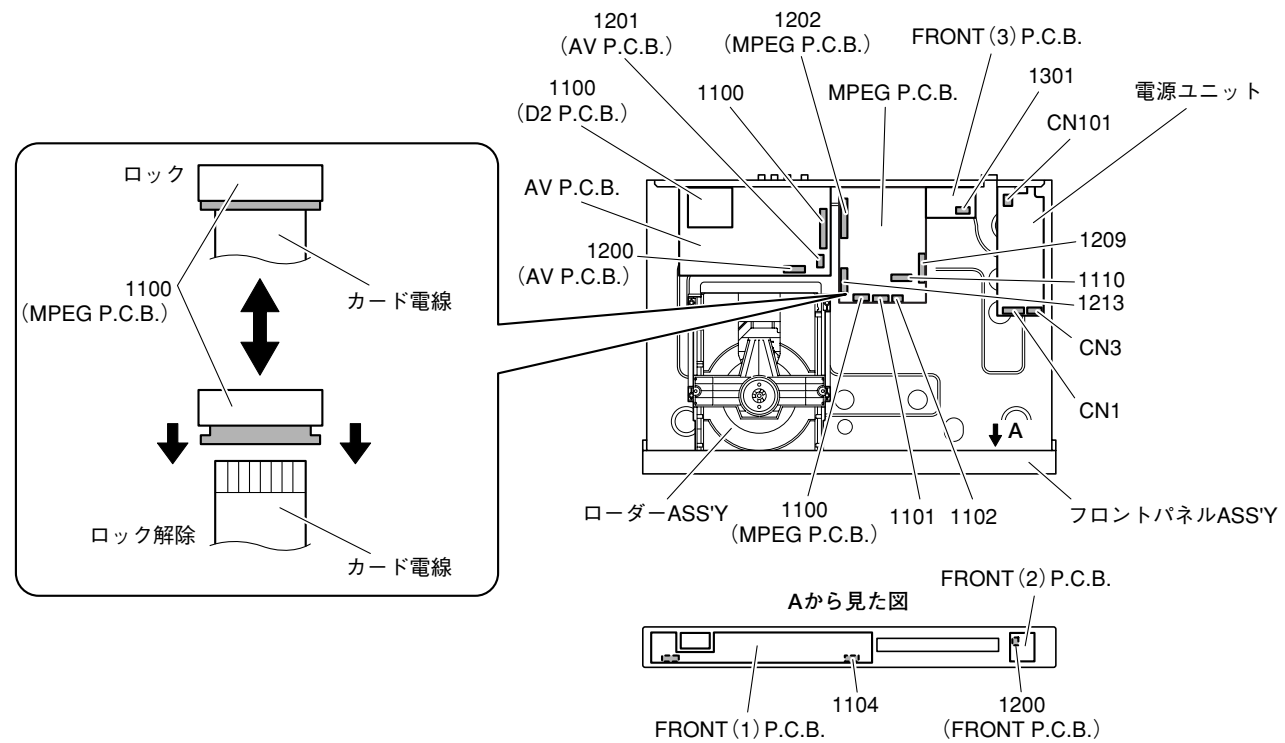

Fig. 1

● 手でディスクトレイを開く方法

- ディスクトレイが出てくるまで、ドライバーでスライダを図に示す矢印の方向に動かします。
- ディスクトレイをそっと引き出します。

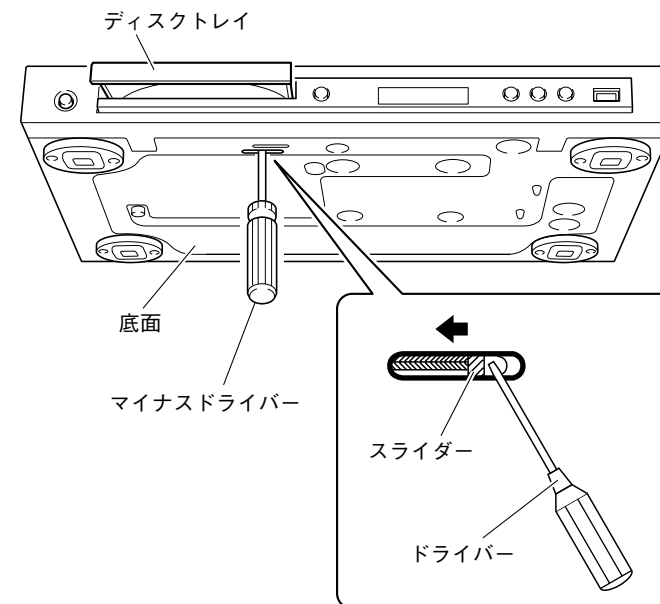

Fig. 2

● 光ピックアップの静電対策

MPEG P.C.B.およびローダーASS'Yを交換した場合、光ピックアップの静電対策のため、光ピックアップP.C.B.の端子をハンダでショートします。

注意)

- 光ピックアップP.C.B.の端子のショート・除去には静電対策されたハンダゴテを使用してください。
- 修理後、ショートしたハンダは取り除いてください。

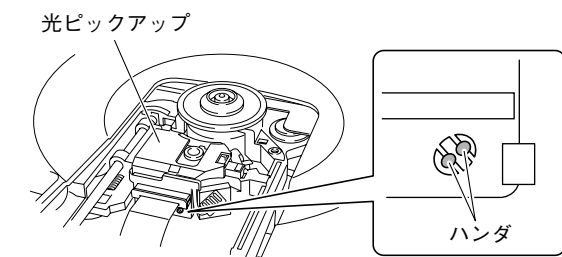

Fig. 3

■ TEST MODE / テストモード

• Starting Test Mode

- Connect the power cable to the AC power outlet.
- Press the "STANDBY/ON" key while simultaneously pressing "PAUSE" and "STOP" keys for 8 seconds or longer.
- The "FV xx" (firmware version) is displayed.

• Display Test

The display changes as shown below by pressing the specified key.

• テストモードの起動

- 電源コードをACコンセントに接続します。
- "PAUSE"キーと"STOP"キーを押しながら、"STANDBY/ON"キーを8秒間以上押し続けます。
- ファームウェアバージョンの"FV xx"が表示されます。

• ディスプレイテスト

指定されたキーを押すと、表示が下記のように変わります。

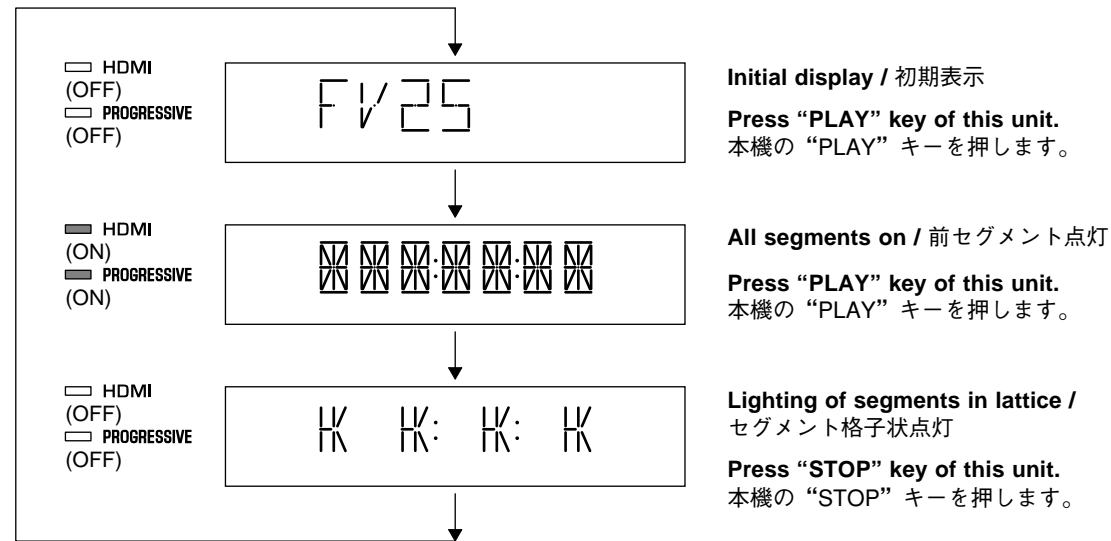

• Panel Key Test

The display changes as shown below by pressing the specified key.

• パネルキーテスト

指定されたキーを押すと、表示が下記のように変わります。

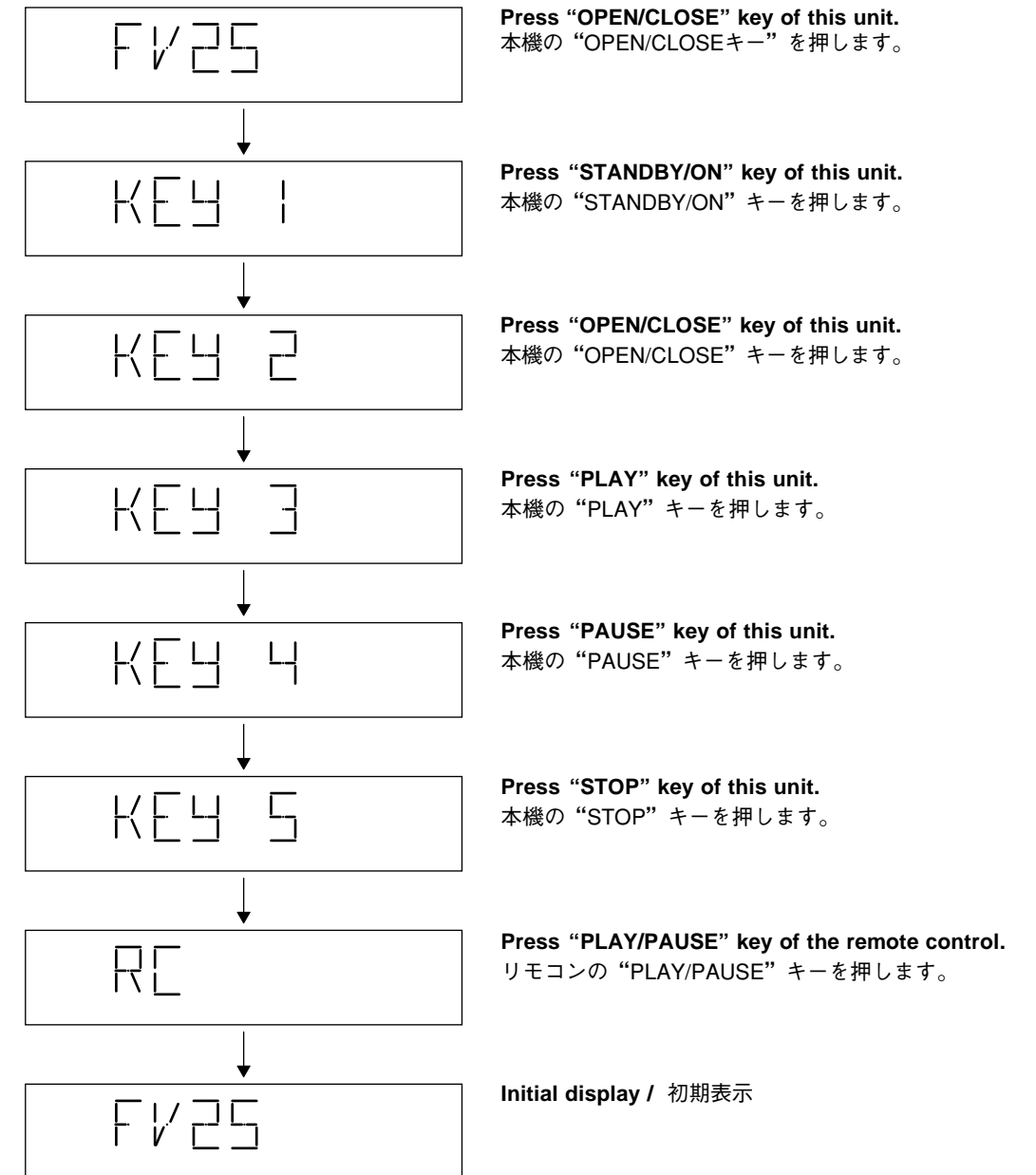

• Canceling Test Mode

Disconnect the power cable from the AC power outlet.

• テストモードの解除

ACコンセントから電源コードを抜きます。

BLOCK DIAGRAM

- Interface between Loader Assy (KMH3133A) and MPEG:
- 1 GND
 - 2 LD_DVD
 - 3 NC
 - 4 HFM
 - 5 MD
 - 6 LD_CD
 - 7 VR_DVD
 - 8 VR_CD
 - 9 NC
 - 10 E
 - 11 VCC
 - 12 VC
 - 13 GND
 - 14 F
 - 15 B
 - 16 A
 - 17 RF
 - 18 CD/DVD
 - 19 D
 - 20 C
 - 21 T-
 - 22 T+
 - 23 F+
 - 24 F-

- Interface between AV and MPEG:
- 1 VSYNC
 - 2 HDMI_INT
 - 3 HSYNC
 - 4 GND
 - 5 SPDIF
 - 6 +5V_STBY
 - 7 DSD_LFE
 - 8 +5VL
 - 9 PCM_LR (DSD_L)
 - 10 +3V3_HDMI
 - 11 PCM_LsRs (DSD_Ls)
 - 12 +3V3_HDMI
 - 13 PCM_ClfE (DSD_C)
 - 14 +3V3_HDMI
 - 15 PCM-Cs (DSD_R)
 - 16 +3V3_HDMI
 - 17 PCM_LtRt (DSD_Rs)
 - 18 GND
 - 19 PCM_LRCK
 - 20 GND
 - 21 PCM_BCLK (DSD_CLK)
 - 22 GND
 - 23 PCM_MLK
 - 24 GND
 - 25 Vsel/P50
 - 26 GND
 - 27 VCLK
 - 28 GND
 - 29 Y0
 - 30 GND
 - 31 Y1
 - 32 GND
 - 33 Y2
 - 34 GND
 - 35 Y3
 - 36 GND
 - 37 Y4
 - 38 GND
 - 39 Y5
 - 40 GND
 - 41 Y6
 - 42 GND
 - 43 Y7
 - 44 GND
 - 45 SCL_1
 - 46 GND
 - 47 SDA_1
 - 48 CEC_WAKEUP
 - 49 CEC
 - 50 CEC_INT

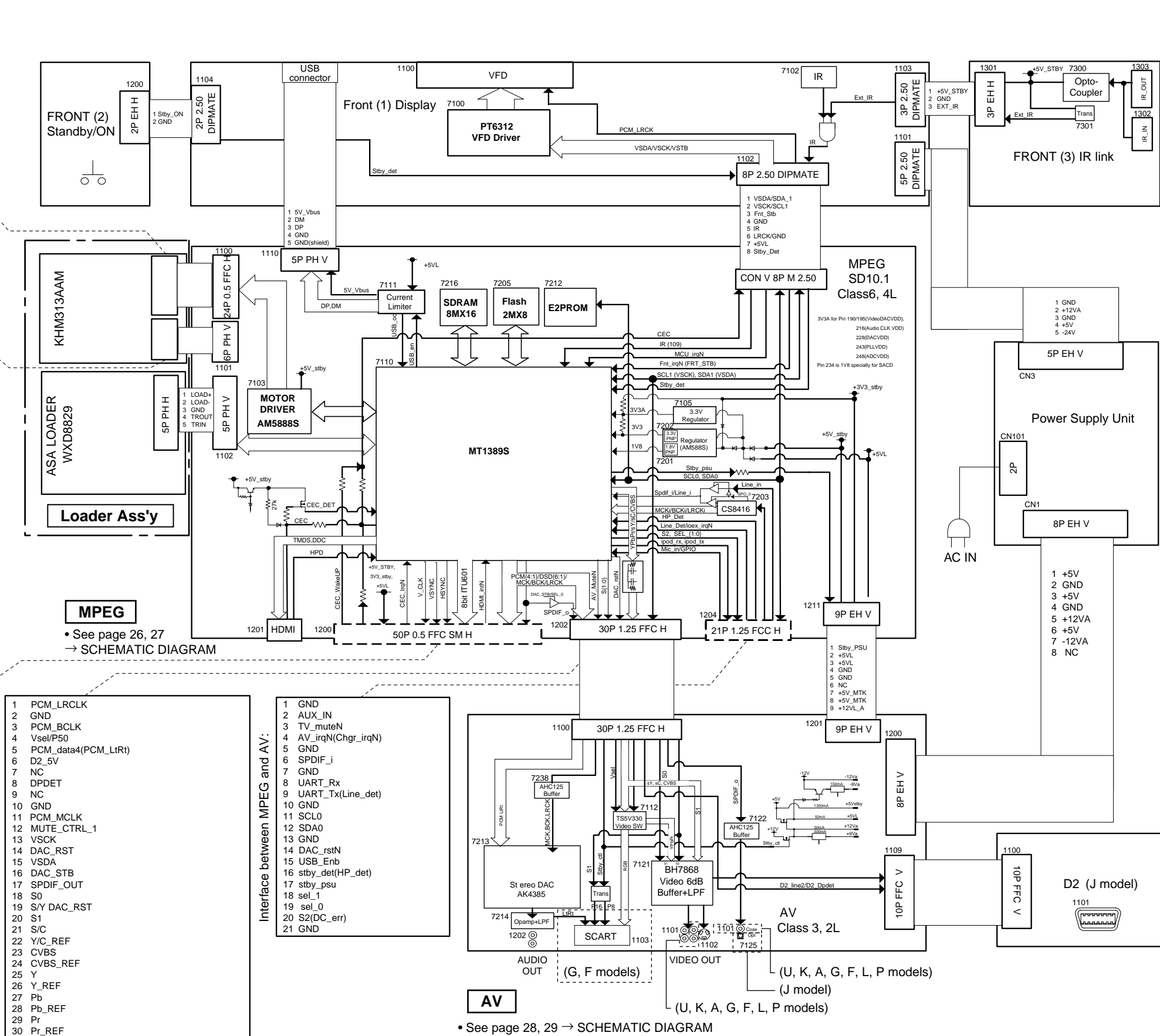

FRONT
• See page 30, 31 → SCHEMATIC DIAGRAM

Power Supply Unit
• See page 33 → SCHEMATIC DIAGRAM

D2
• See page 32 → SCHEMATIC DIAGRAM

AV
• See page 28, 29 → SCHEMATIC DIAGRAM

MPEG
• See page 26, 27 → SCHEMATIC DIAGRAM

- Interface between MPEG and AV:
- 1 GND
 - 2 AUX_IN
 - 3 TV_muteN
 - 4 AV_irqN(Chgr_irqN)
 - 5 GND
 - 6 SPDIF_i
 - 7 GND
 - 8 UART_Rx
 - 9 UART_Tx(Line_det)
 - 10 GND
 - 11 SCL0
 - 12 SDA0
 - 13 GND
 - 14 DAC_rstN
 - 15 USB_Enb
 - 16 stby_det(HP_det)
 - 17 stby_psu
 - 18 sel_1
 - 19 sel_0
 - 20 S2(DC_err)
 - 21 GND

1 ■ WIRING DIAGRAM

1
2
3
4
5
6
7

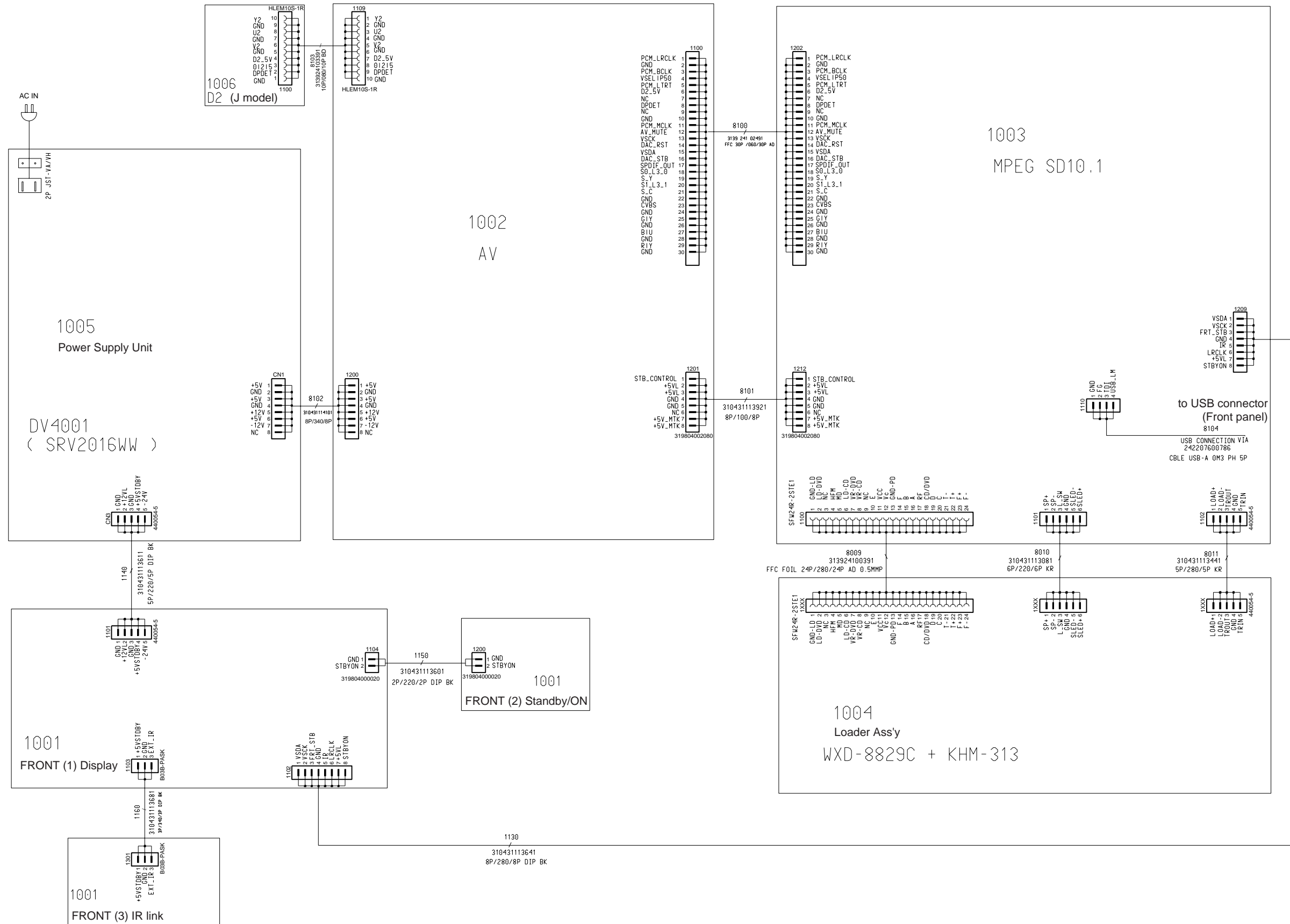

PRINTED CIRCUIT BOARDS

FOR INFORMATION ONLY (COMPONENT PARTS NOT AVAILABLE)

MPEG (Top view)

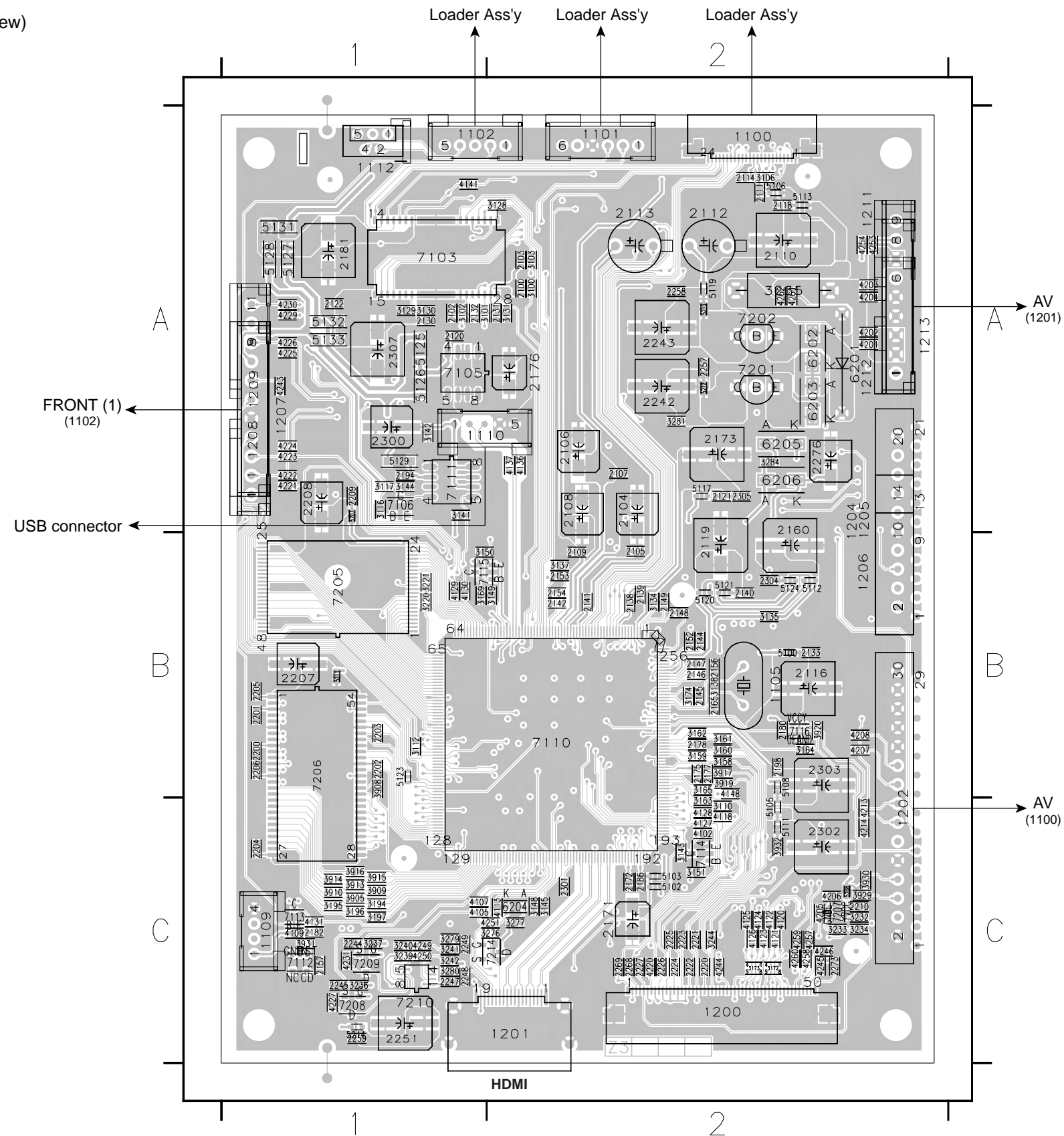

The first digit of a component indicates the component type.

- 1xxx : Connector 3xxx : Resistor 5xxx : Coil 7xxx : IC, Transistor, FET
- 2xxx : Capacitor 4xxx : SMD jumper 6xxx : Diode 9xxx : Wire jumper

1102	A2
1101	A2
1100	A2
2113	A2
2112	A2
2110	A2
7103	A2
2106	A2
2107	A2
2108	A2
2104	A2
2105	A2
2119	A2
2160	A2
2116	A2
2110	A2
2303	A2
2302	A2
2301	A2
7206	A2
7207	A2
7205	A2
7208	A2
7209	A2
7210	A2
7211	A2
1200	A2
1201	A2
1202	A2
1203	A2
1204	A2
1205	A2
1206	A2
1207	A2
1208	A2
1209	A2
1210	A2
1211	A2
1212	A2
1213	A2
1214	A2
1215	A2
1216	A2
1217	A2
1218	A2
1219	A2
1220	A2
1221	A2
1222	A2
1223	A2
1224	A2
1225	A2
1226	A2
1227	A2
1228	A2
1229	A2
1230	A2
1231	A2
1232	A2
1233	A2
1234	A2
1235	A2
1236	A2
1237	A2
1238	A2
1239	A2
1240	A2
1241	A2
1242	A2
1243	A2
1244	A2
1245	A2
1246	A2
1247	A2
1248	A2
1249	A2
1250	A2
1251	A2
1252	A2
1253	A2
1254	A2
1255	A2
1256	A2
1257	A2
1258	A2
1259	A2
1260	A2
1261	A2
1262	A2
1263	A2
1264	A2
1265	A2
1266	A2
1267	A2
1268	A2
1269	A2
1270	A2
1271	A2
1272	A2
1273	A2
1274	A2
1275	A2
1276	A2
1277	A2
1278	A2
1279	A2
1280	A2
1281	A2
1282	A2
1283	A2
1284	A2
1285	A2
1286	A2
1287	A2
1288	A2
1289	A2
1290	A2
1291	A2
1292	A2
1293	A2
1294	A2
1295	A2
1296	A2
1297	A2
1298	A2
1299	A2
1300	A2

MPEG (Bottom view)

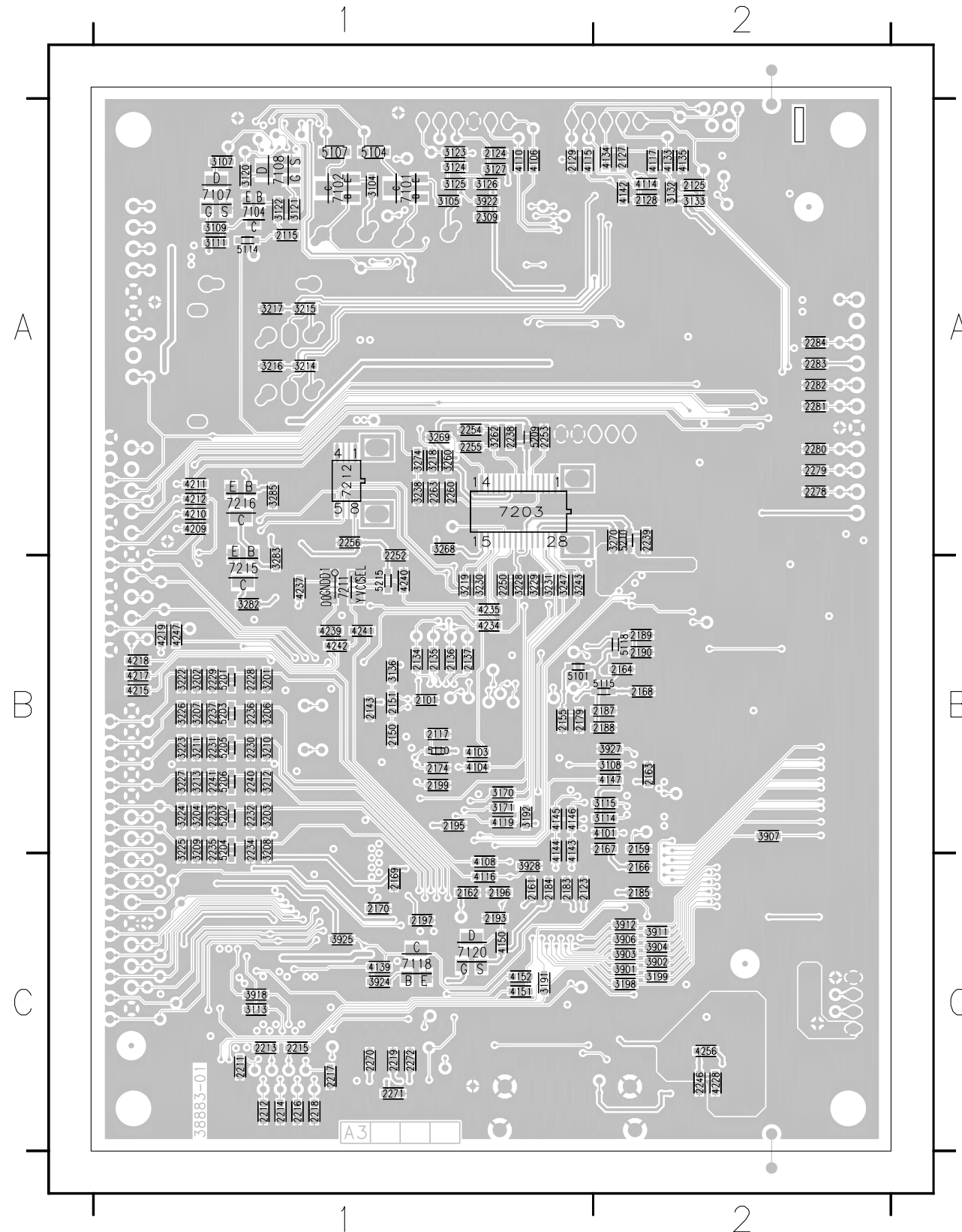

The first digit of a component indicates the component type.

- 1xxx : Connector
- 2xxx : Capacitor
- 3xxx : Resistor
- 4xxx : SMD jumper
- 5xxx : Coil
- 6xxx : Diode
- 7xxx : IC, Transistor, FET
- 8xxx : Diode
- 9xxx : Wire jumper

2278	A2
2277	C1
2276	C1
2275	C1
2274	C1
2273	A1
2272	A1
2271	A1
2270	C1
2269	C1
2268	C1
2267	C1
2266	C1
2265	A1
2264	A1
2263	A1
2262	A1
2261	A1
2260	A1
2259	A1
2258	A1
2257	A1
2256	A1
2255	A1
2254	A1
2253	A1
2252	A1
2251	A1
2250	A1
2249	A1
2248	A1
2247	A1
2246	A1
2245	A1
2244	A1
2243	A1
2242	A1
2241	A1
2240	A1
2239	A1
2238	A1
2237	A1
2236	A1
2235	A1
2234	A1
2233	A1
2232	A1
2231	A1
2230	A1
2229	A1
2228	A1
2227	A1
2226	A1
2225	A1
2224	A1
2223	A1
2222	A1
2221	A1
2220	A1
2219	A1
2218	A1
2217	A1
2216	A1
2215	A1
2214	A1
2213	A1
2212	A1
7211	A1
7210	A1
7209	A1
7208	A1
7207	A1
7206	A1
7205	A1
7204	A1
7203	A1
7202	A1
7201	A1
7200	A1
7199	A1
7198	A1
7197	A1
7196	A1
7195	A1
7194	A1
7193	A1
7192	A1
7191	A1
7190	A1
7189	A1
7188	A1
7187	A1
7186	A1
7185	A1
7184	A1
7183	A1
7182	A1
7181	A1
7180	A1
7179	A1
7178	A1
7177	A1
7176	A1
7175	A1
7174	A1
7173	A1
7172	A1
7171	A1
7170	A1
7169	A1
7168	A1
7167	A1
7166	A1
7165	A1
7164	A1
7163	A1
7162	A1
7161	A1
7160	A1
7159	A1
7158	A1
7157	A1
7156	A1
7155	A1
7154	A1
7153	A1
7152	A1
7151	A1
7150	A1
7149	A1
7148	A1
7147	A1
7146	A1
7145	A1
7144	A1
7143	A1
7142	A1
7141	A1
7140	A1
7139	A1
7138	A1
7137	A1
7136	A1
7135	A1
7134	A1
7133	A1
7132	A1
7131	A1
7130	A1
7129	A1
7128	A1
7127	A1
7126	A1
7125	A1
7124	A1
7123	A1
7122	A1
7121	A1
7120	A1
7119	A1
7118	A1
7117	A1
7116	A1
7115	A1
7114	A1
7113	A1
7112	A1
7111	A1
7110	A1
7109	A1
7108	A1
7107	A1
7106	A1
7105	A1
7104	A1
7103	A1
7102	A1
7101	A1
7100	A1
7099	A1
7098	A1
7097	A1
7096	A1
7095	A1
7094	A1
7093	A1
7092	A1
7091	A1
7090	A1
7089	A1
7088	A1
7087	A1
7086	A1
7085	A1
7084	A1
7083	A1
7082	A1
7081	A1
7080	A1
7079	A1
7078	A1
7077	A1
7076	A1
7075	A1
7074	A1
7073	A1
7072	A1
7071	A1
7070	A1
7069	A1
7068	A1
7067	A1
7066	A1
7065	A1
7064	A1
7063	A1
7062	A1
7061	A1
7060	A1
7059	A1
7058	A1
7057	A1
7056	A1
7055	A1
7054	A1
7053	A1
7052	A1
7051	A1
7050	A1
7049	A1
7048	A1
7047	A1
7046	A1
7045	A1
7044	A1
7043	A1
7042	A1
7041	A1
7040	A1
7039	A1
7038	A1
7037	A1
7036	A1
7035	A1
7034	A1
7033	A1
7032	A1
7031	A1
7030	A1
7029	A1
7028	A1
7027	A1
7026	A1
7025	A1
7024	A1
7023	A1
7022	A1
7021	A1
7020	A1
7019	A1
7018	A1
7017	A1
7016	A1
7015	A1
7014	A1
7013	A1
7012	A1
7011	A1
7010	A1
7009	A1
7008	A1
7007	A1
7006	A1
7005	A1
7004	A1
7003	A1
7002	A1
7001	A1
7000	A1
6999	A1
6998	A1
6997	A1
6996	A1
6995	A1
6994	A1
6993	A1
6992	A1
6991	A1
6990	A1
6989	A1
6988	A1
6987	A1
6986	A1
6985	A1
6984	A1
6983	A1
6982	A1
6981	A1
6980	A1
6979	A1
6978	A1
6977	A1
6976	A1
6975	A1
6974	A1
6973	A1
6972	A1
6971	A1
6970	A1
6969	A1
6968	A1
6967	A1
6966	A1
6965	A1
6964	A1
6963	A1
6962	A1
6961	A1
6960	A1
6959	A1
6958	A1
6957	A1
6956	A1
6955	A1
6954	A1
6953	A1
6952	A1
6951	A1
6950	A1
6949	A1
6948	A1

The first digit of a component indicates the component type.

1xxx : Connector 3xxx : Resistor 5xxx : Coil 7xxx : IC, Transistor, FET
 2xxx : Capacitor 4xxx : SMD jumper 6xxx : Diode 9xxx : Wire jumper

FRONT (1) (Top view)

DISPLAY

1100 B8 1102 C15 1104 C2 1106 B16 1108 B14 2103 A23 2110 B19 2114 B23 6122 A4
 1101 B23 1103 C22 1105 B18 1107 B2 2100 C17 2106 A13 2112 C18 6121 A4 7102 B13

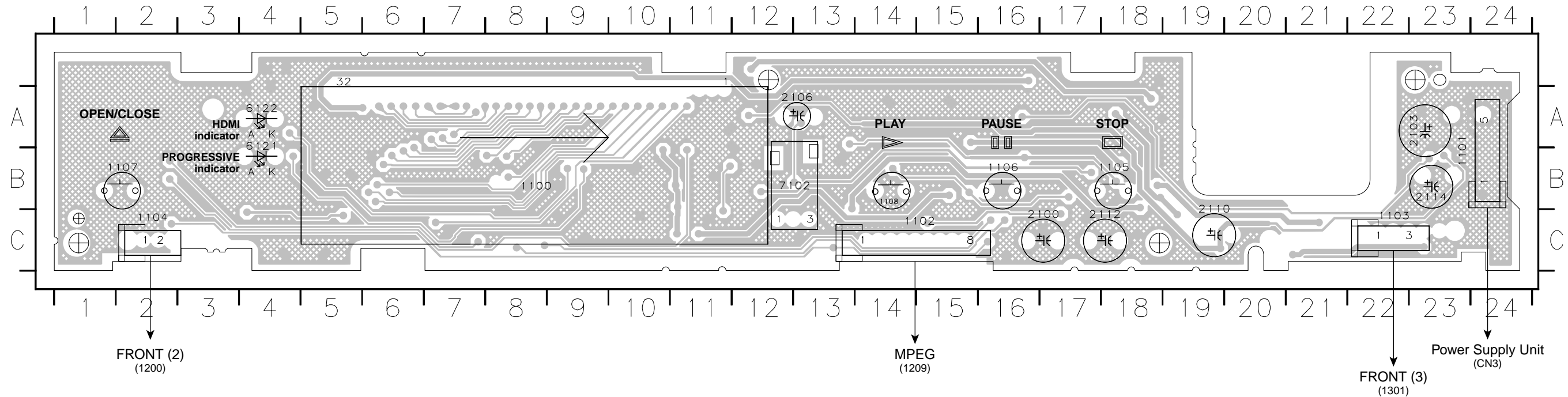

FRONT (1) (Bottom view)

DISPLAY

2101 B10 2111 C7 3101 B12 3107 A14 3113 B15 3119 A10 3125 A14 3131 A15 3137 A16 3143 A19 3149 C15 6100 B22 6109 B9 7104 A9
 2102 A2 2113 B10 3102 A11 3108 A20 3114 C15 3120 B10 3126 A15 3132 A16 3138 A16 3144 A19 3150 B12 6101 B13 6110 B23 7105 A11
 2104 A19 2115 A7 3103 B9 3109 B16 3115 C15 3121 C2 3127 A15 3133 A16 3139 A18 3145 A19 3151 B13 6102 B2 6112 B23 7106 A8
 2105 B12 2116 C23 3104 A24 3110 C15 3116 B2 3122 B2 3128 A15 3134 A16 3140 A18 3146 B16 3152 A14 6106 A14 6114 B10
 2107 B13 2118 C4 3105 B13 3111 B15 3117 B21 3123 A11 3129 A15 3135 A16 3141 A19 3147 B15 3153 A20 6107 A14 7100 B17
 2109 C19 2119 B16 3106 A21 3112 B15 3118 A10 3124 A14 3130 A15 3136 A17 3142 A19 3148 C16 5100 B16 6108 B11 7103 A10

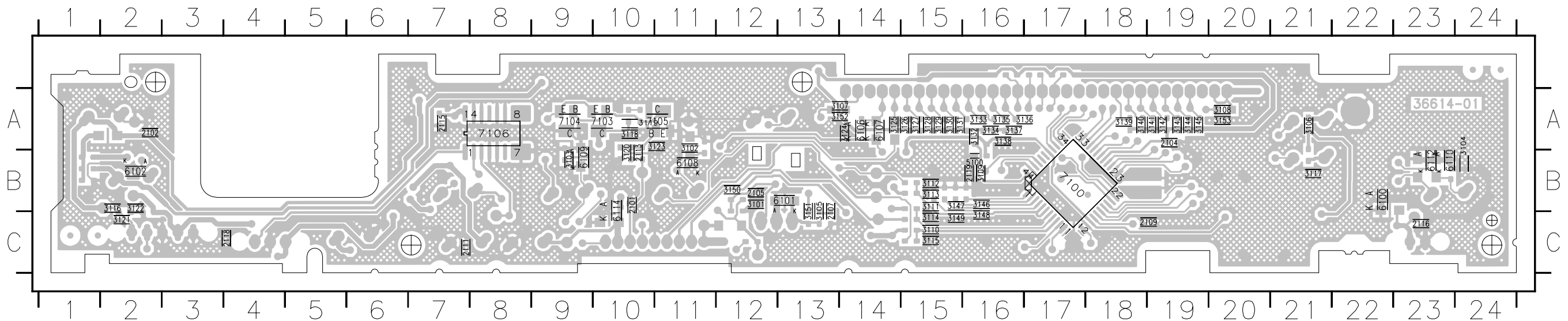

The first digit of a component indicates the component type.

1xxx : Connector 3xxx : Resistor 5xxx : Coil 7xxx : IC, Transistor, FET
 2xxx : Capacitor 4xxx : SMD jumper 6xxx : Diode 9xxx : Wire jumper

FRONT (2) (Top view)

STANDBY/ON

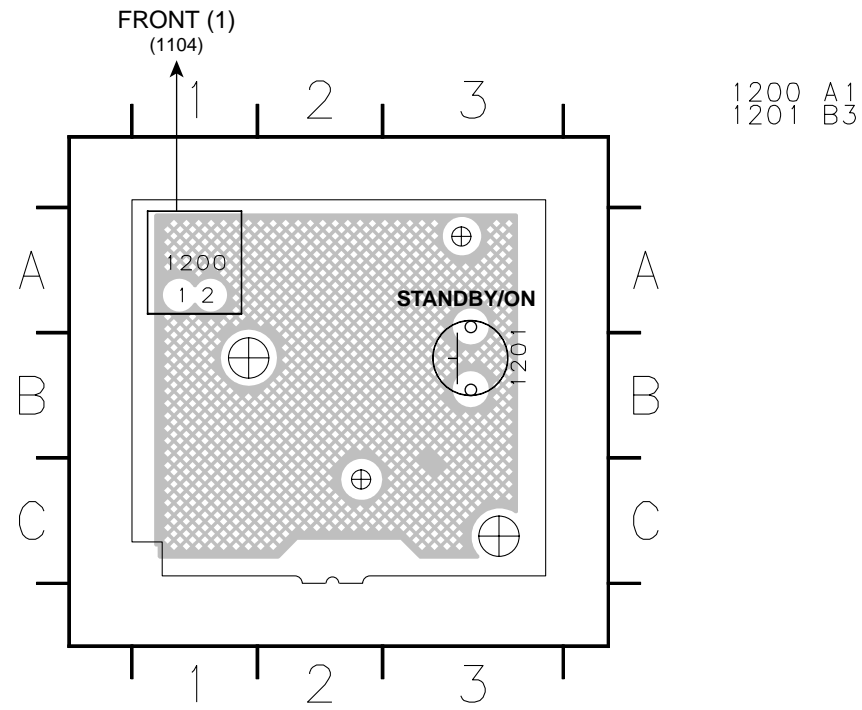

FRONT (3) (Top view)

IR LINK

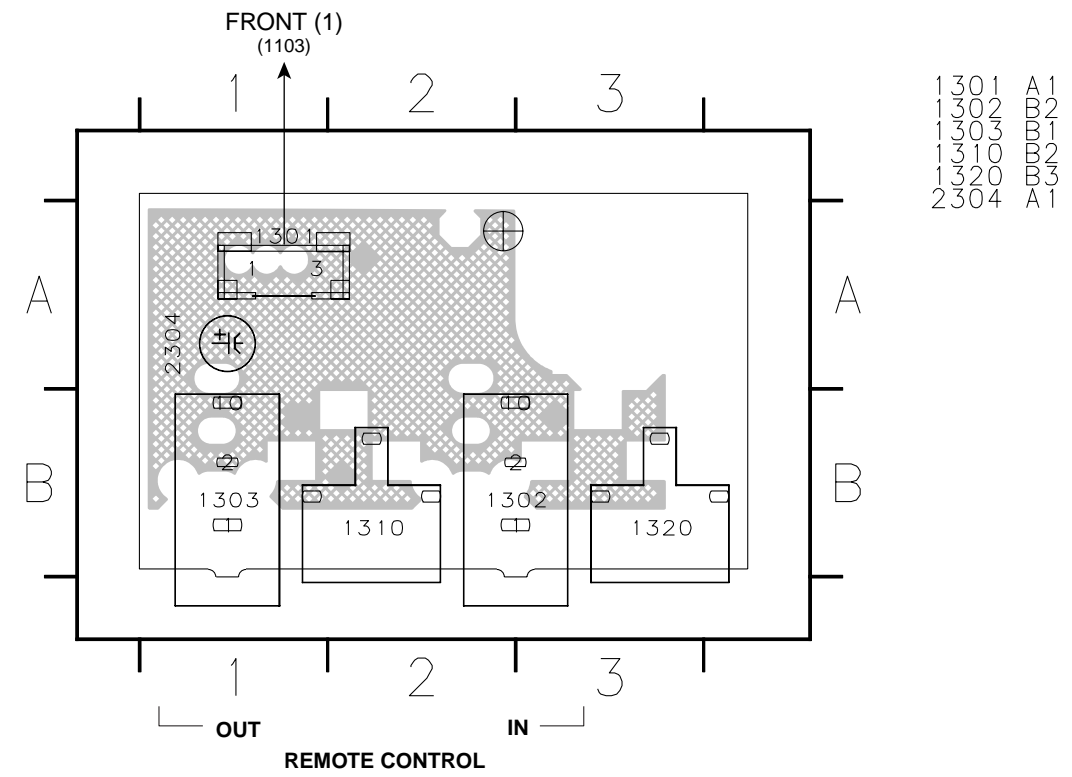

FRONT (2) (Bottom view)

STANDBY/ON

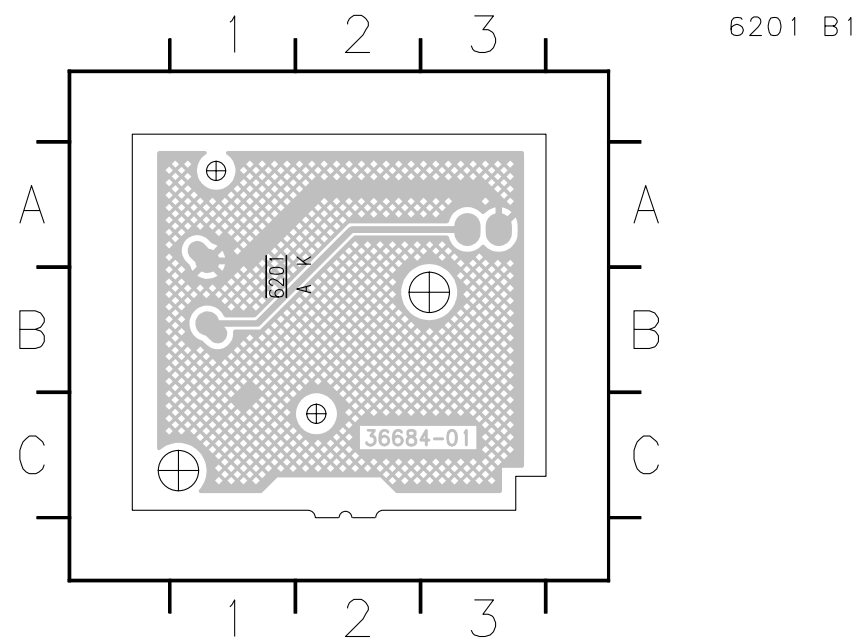

FRONT (3) (Bottom view)

IR LINK

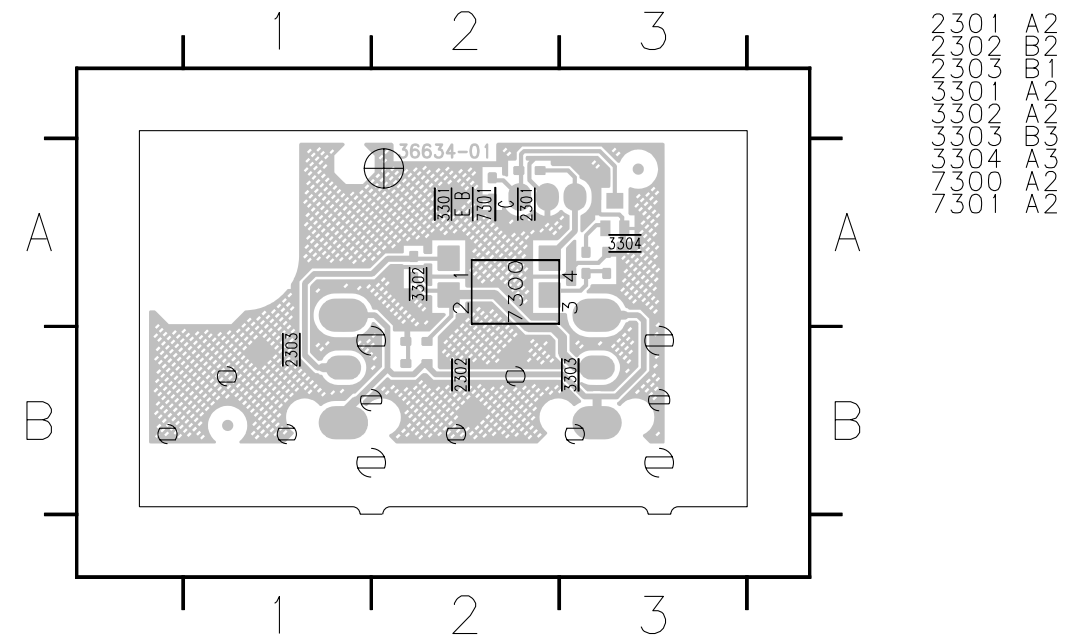

The first digit of a component indicates the component type.

- | | | | |
|------------------|-------------------|--------------|----------------------------|
| 1xxx : Connector | 3xxx : Resistor | 5xxx : Coil | 7xxx : IC, Transistor, FET |
| 2xxx : Capacitor | 4xxx : SMD jumper | 6xxx : Diode | 9xxx : Wire jumper |

D2 (Top view)

J model

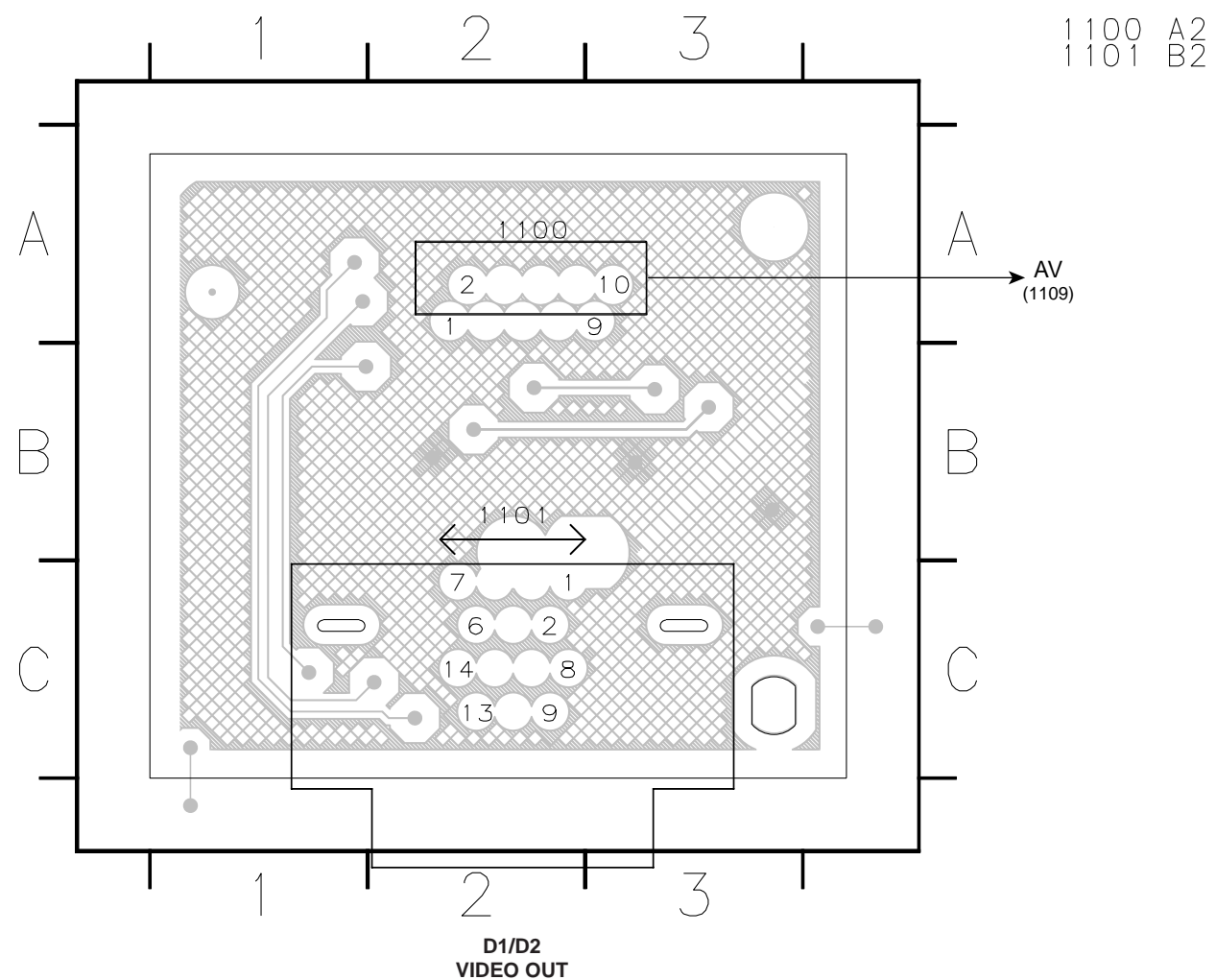

D2 (Bottom view)

J model

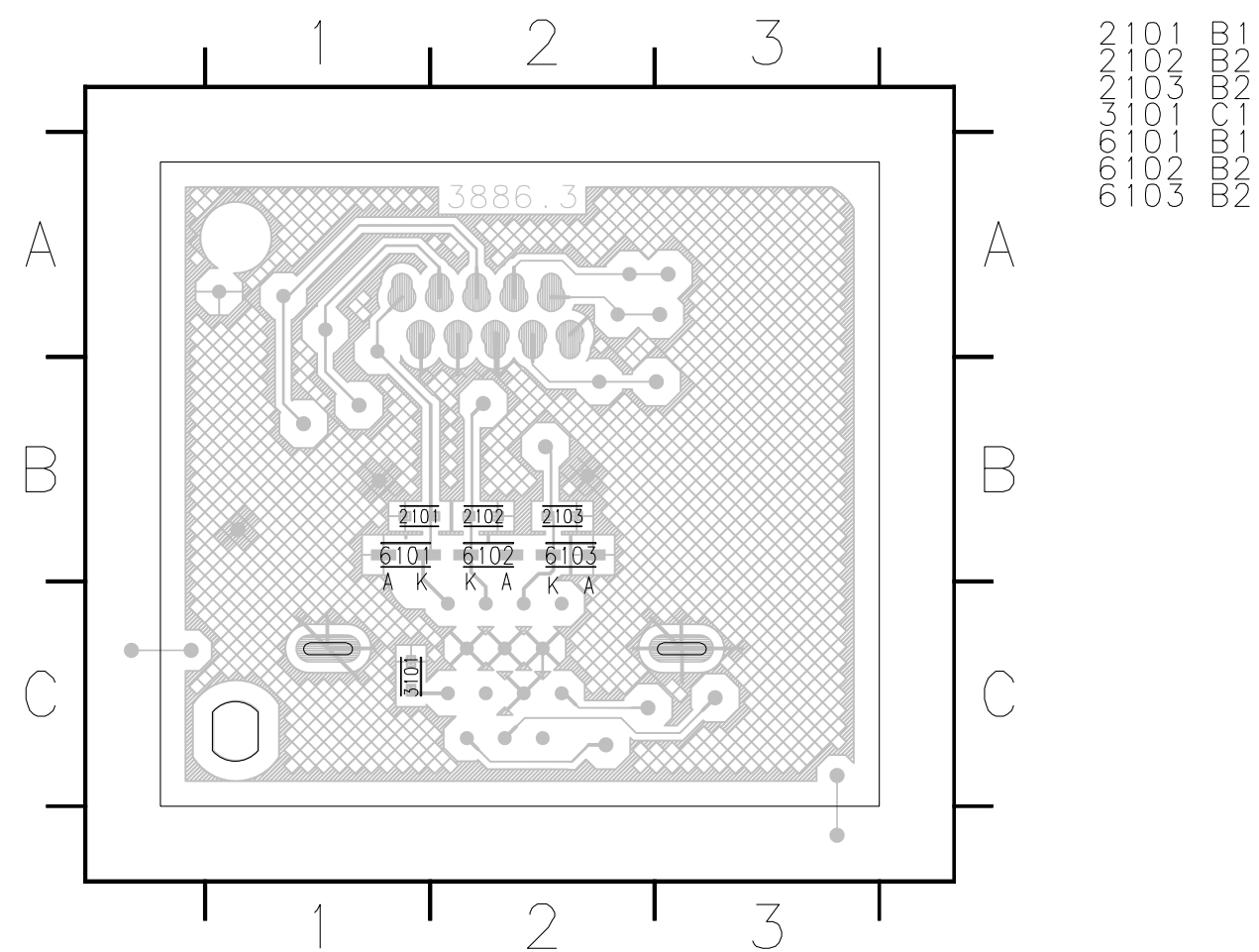

POWER SUPPLY UNIT (Top view)

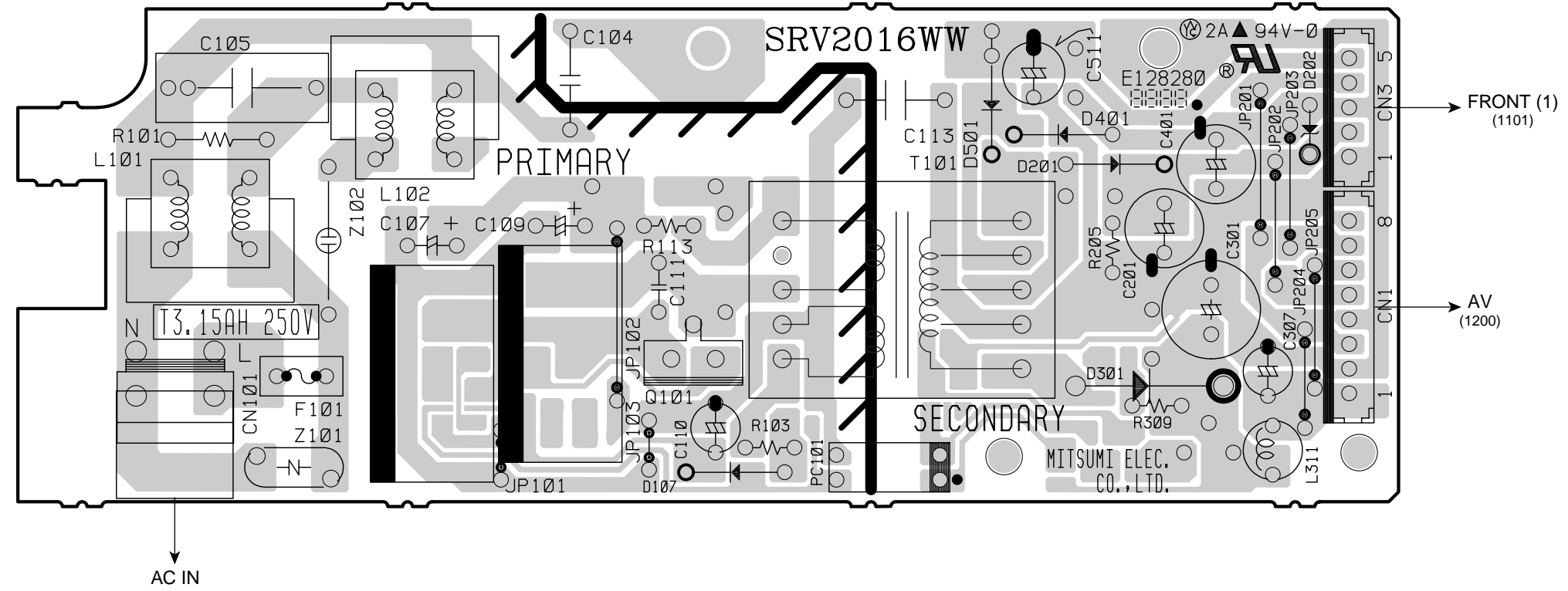

POWER SUPPLY UNIT (Bottom view)

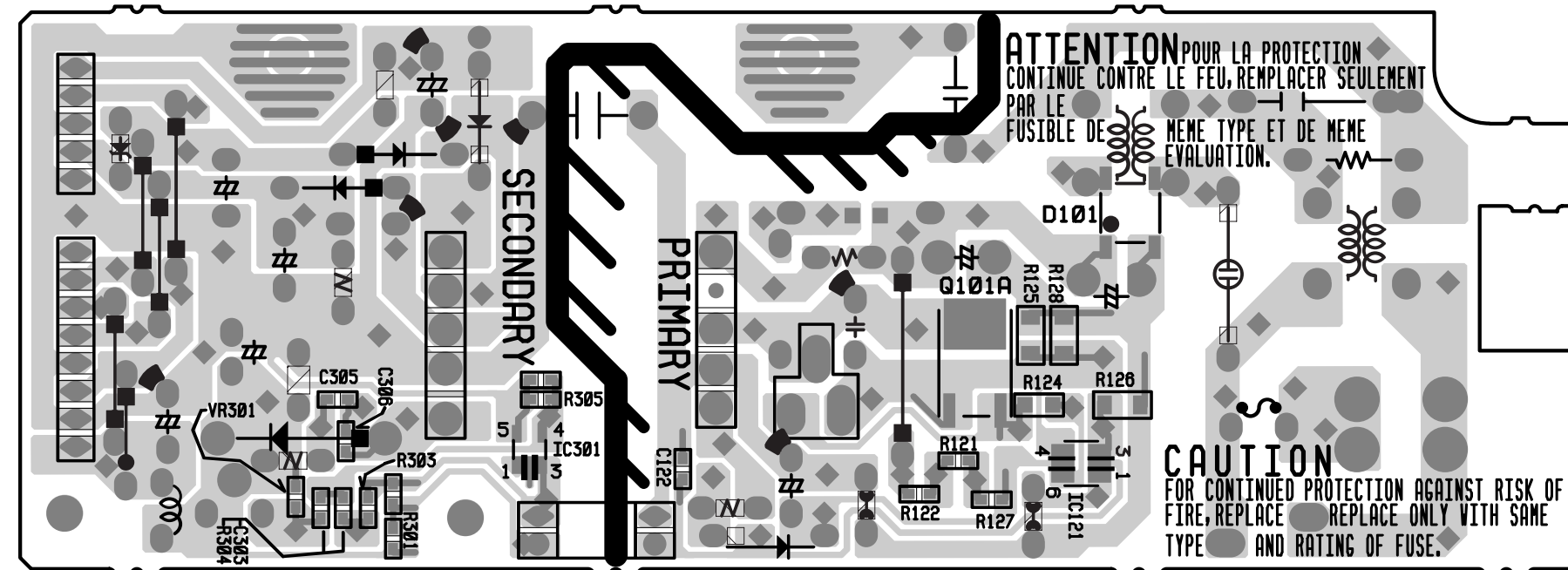

SCHEMATIC DIAGRAMS

FOR INFORMATION ONLY (COMPONENT PARTS NOT AVAILABLE)

MPEG 1/2

The first digit of a component indicates the component type.

- 1xxx : Connector 3xxx : Resistor 5xxx : Coil 7xxx : IC, Transistor, FET
- 2xxx : Capacitor 4xxx : SMD jumper 6xxx : Diode 9xxx : Wire jumper

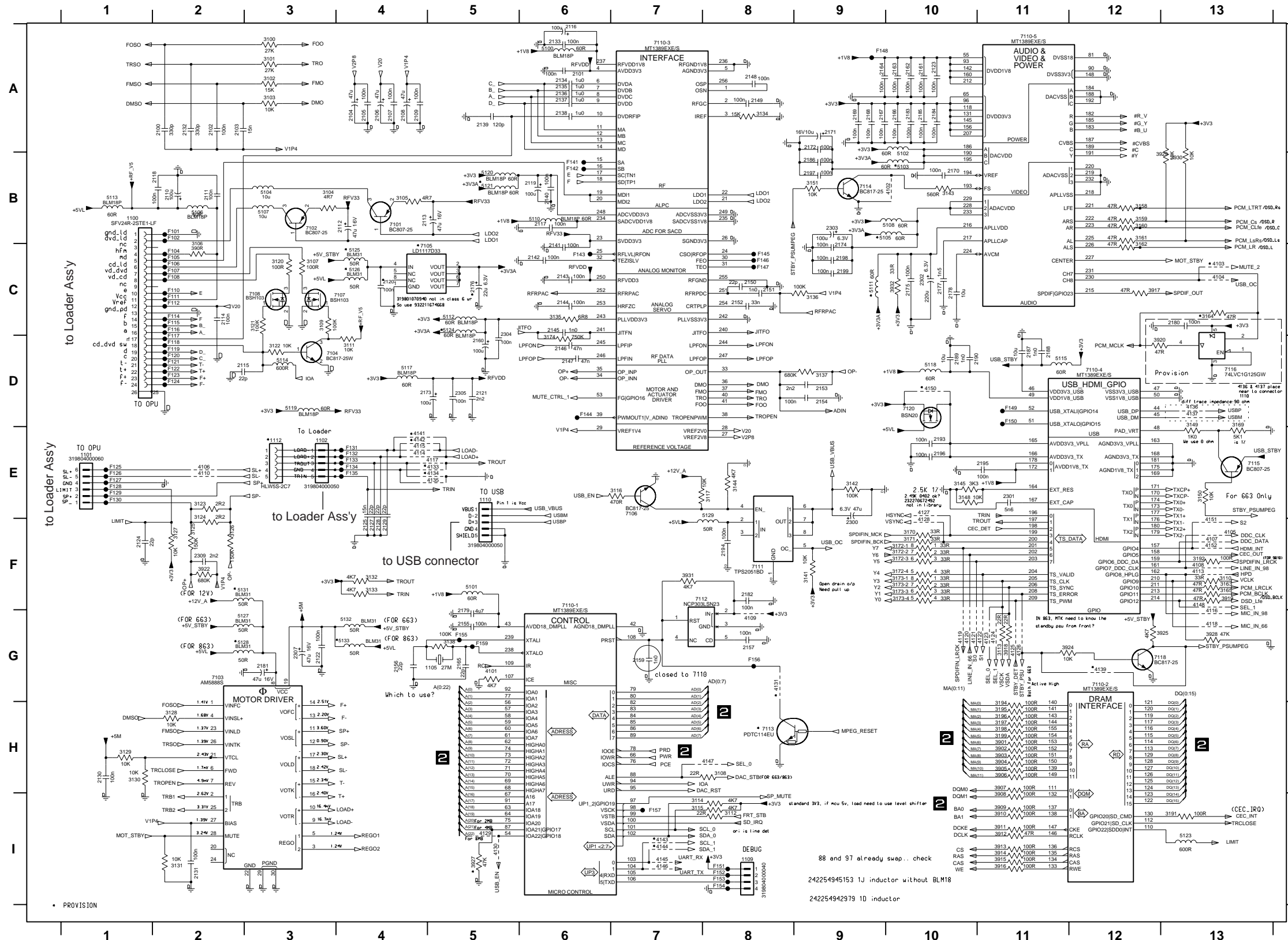

1100 B1	3106 C2	4123 G11	F149 D11
1101 E1	3107 C3	4124 G11	F150 D11
1102 E3	3108 H8	4125 G11	F151 B8
1105 G5	3109 C3	4126 G11	F152 B8
1109 B8	3110 F13	4127 E10	F153 B8
1110 E5	3111 D4	4128 F10	F154 B8
1112 E3	3112 B8	4129 B5	F155 G5
2100 A2	3113 G11	4130 B5	F156 G8
2101 A6	3114 F7	4131 G8	F157 F7
2102 A2	3115 F7	4132 E5	F158 G5
2103 A2	3116 E7	4133 E5	
2104 A4	3117 E8	4134 E5	
2105 A4	3120 C3	4136 D13	
2106 A4	3121 C3	4137 D13	
2107 A4	3122 F2	4138 D13	
2108 A4	3123 E2	4141 E4	
2109 A4	3124 F2	4142 E4	
2110 B2	3125 F2	4143 F7	
2111 B2	3126 F2	4144 F7	
2112 B4	3127 F2	4145 F7	
2113 B4	3128 H2	4146 F7	
2114 C2	3129 H1	4147 H8	
2115 D2	3130 H1	4148 F13	
2116 A6	3131 I2	4150 D10	
2117 B6	3132 F6	4151 F13	
2118 B2	3133 F4	4152 D13	
2119 B6	3134 A8	5100 A6	
2120 C4	3135 C6	5101 F5	
2121 D5	3136 C9	5102 B10	
2122 G3	3137 D9	5103 B10	
2123 A10	3138 G5	5104 B5	
2124 F1	3141 F9	5105 B9	
2125 F4	3142 E9	5106 B2	
2127 F4	3143 B10	5107 B3	
2128 F4	3144 E8	5108 B10	
2129 F4	3145 E10	5110 B6	
2130 H1	3148 E10	5111 C9	
2131 H2	3149 D13	5112 C5	
2132 A2	3150 E13	5113 B1	
2133 A6	3151 B9	5114 D3	
2134 A6	3158 B12	5115 D11	
2135 A6	3159 B12	5117 D4	
2136 A6	3160 B12	5118 D10	
2137 A6	3161 B12	5119 D3	
2138 A6	3162 C12	5120 B5	
2139 A5	3163 F13	5121 B5	
2140 B6	3164 D13	5123 B13	
2141 C6	3165 F13	5124 C5	
2142 C6	3169 D13	5125 C4	
2143 C6	3170 F10	5126 C4	
2144 C6	3171 F10	5127 G2	
2145 C6	3172-2 F10	5128 G2	
2146 D6	3172-2 F10	5129 E8	
2147 D6	3172-3 F10	5131 F2	
2148 A8	3172-4 F10	5132 G4	
2149 A8	3173-1 F10	5133 G4	
2150 C8	3173-2 F10	5134 B4	
2151 C8	3173-3 F10	7102 B3	
2152 C8	3173-4 F10	7103 G2	
2153 D9	3174 D6	7104 D3	
2154 D9	3191 H3	7105 C4	
2155 G5	3192 F13	7106 E7	
2156 G8	3194 H11	7107 C3	
2157 G8	3195 H11	7108 C3	
2159 G7	3196 H11	7110-1 F6	
2160 D5	3197 H11	7110-2 G12	
2161 A10	3198 H11	7110-3 A7	
2162 A10	3199 H11	7110-4 D12	
2163 A10	3901 H11	7110-5 A11	
2164 A9	3902 H11	7111 F8	
2165 G5	3903 H11	7112 F7	
2166 A10	3904 H11	7113 H8	
2167 A9	3905 H11	7114 B9	
2168 A9	3906 H11	7115 E13	
2169 A9	3907 H11	7116 D13	
2170 B10	3908 H11	7118 G12	
2171 A9	3909 H11	7120 D10	
2172 A9	3910 H11	F101 B2	
2173 D4	3911 H11	F102 B2	
2174 C9	3912 H11	F104 C2	
2175 C10	3913 H11	F105 C2	
2176 C5	3914 H11	F106 C2	
2177 C10	3915 H11	F107 C2	
2178 C10	3916 H11	F108 C2	
2179 G5	3917 C12	F110 C2	
2180 C13	3918 G11	F111 C2	
2181 G3	3919 F13	F112 C2	
2182 F8	3920 D12	F114 C2	
2183 A10	3921 D12	F115 C2	
2184 A10	3924 G11	F116 C2	
2185 A10	3925 G13	F117 D2	
2186 B9	3927 I5	F118 D2	
2187 D11	3928 G13	F119 D2	
2188 D11	3929 B13	F120 D2	
2189 D10	3930 B13	F121 D2	
2190 D10	3931 F7	F122 D2	
2193 E10	3932 C10	F123 D2	
2194 F8	4101 G5	F124 D2	
2195 E11	4102 B10	F125 E1	
2196 E10	4103 C13	F126 E1	
2197 B9	4104 C13	F127 E1	
2198 C9	4105 F13	F128 E1	
2199 C9	4106 E2	F129 E1	
2300 F9	4107 F13	F130 E1	
2301 E11	4108 F13	F131 E4	
2302 C10	4109 G6	F132 E4	
2303 B9	4110 E2	F133 E4	
2304 C5	4113 F13	F134 E4	
2305 D5	4114 E4	F135 E4	
2307 G3	4115 E4	F141 B6	
2309 F2	4116 G13	F142 B6	
3100 A3	4117 E5	F143 C6	
3101 A3	4118 G13	F144 D6	
3102 A3	4119 G10	F145 C8	
3103 A3	4120 G10	F146 C8	
3104 B3	4121 G10	F147 C8	
3105 B4	4122 G11	F148 A9	

★ Components having special characteristics are marked with a triangle and must be replaced with parts having specifications equal to those originally installed.
 ● 印のある部品は、安全性確保部品を示しています。部品の交換が必要な場合、パーツリストに記載されている部品を使用してください。
 ● 本回路図は標準回路図です。改良のため予告なく変更することがございます。

The first digit of a component indicates the component type.

- 1xxx : Connector 3xxx : Resistor 5xxx : Coil 7xxx : IC, Transistor, FET
- 2xxx : Capacitor 4xxx : SMD jumper 6xxx : Diode 9xxx : Wire jumper

MPEG 2/2

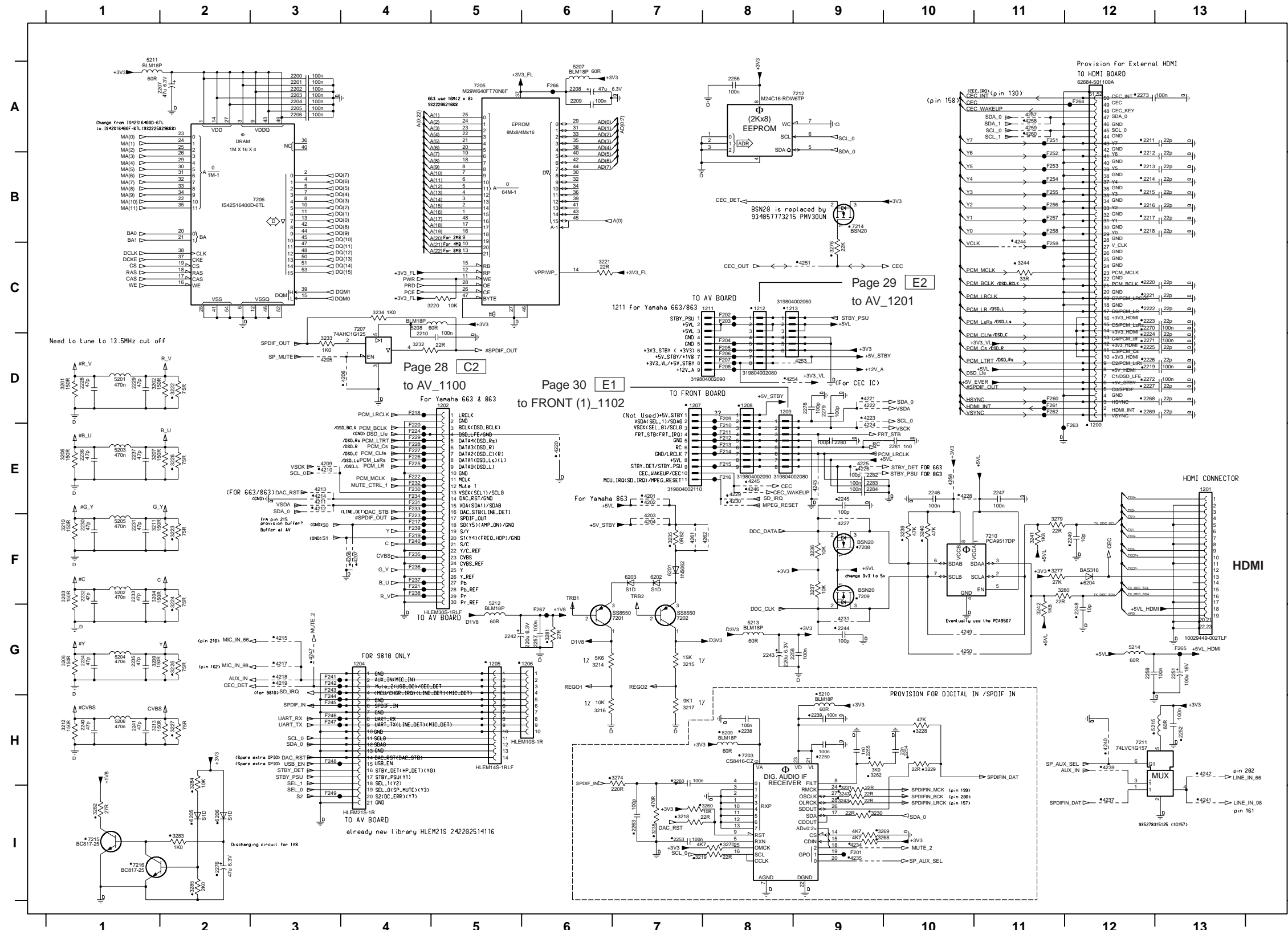

1200 D12	3231 I9	7215 H1
1201 E13	3232 D4	7216 H1
1202 D5	3233 D3	F201 I9
1204 G4	3234 C4	F202 C8
1205 G5	3235 F7	F203 C8
1206 G6	3236 F9	F204 D8
1207 D7	3237 F9	F205 D8
1208 D8	3238 I7	F206 D8
1209 D8	3239 F10	F207 D8
1211 C8	3240 F10	F208 D8
1212 C8	3241 F11	F209 D8
1213 C8	3242 G11	F210 E8
2200 A3	3243 I9	F211 E8
2201 A3	3244 C11	F212 E8
2202 A3	3247 I9	F213 E8
2203 A3	3260 I8	F214 E8
2204 A3	3262 H9	F215 E8
2205 A3	3268 I10	F216 E8
2206 A3	3269 H10	F217 F4
2207 A2	3270 I8	F218 D4
2208 A6	3274 H7	F219 F4
2209 A6	3276 C9	F220 E4
2210 C4	3277 F11	F221 F4
2211 A12	3279 F11	F222 E4
2212 B12	3280 F11	F223 F4
2213 B12	3281 G6	F224 E4
2214 B12	3282 I1	F225 E4
2215 B12	3283 I2	F226 E4
2216 B12	3284 H2	F227 E4
2217 B12	3285 I2	F228 E4
2218 B12	4201 E7	F229 E4
2219 D12	4202 E7	F230 E4
2220 C12	4203 F7	F231 E4
2221 C12	4204 F7	F232 E4
2222 C12	4205 D3	F233 E4
2223 C12	4206 D4	F234 E4
2224 D12	4207 F4	F235 F4
2225 D12	4208 F4	F236 F4
2226 D12	4209 E3	F237 F4
2227 D12	4210 E3	F238 F4
2228 D1	4211 E3	F239 F4
2229 D1	4212 E3	F240 F4
2230 F1	4213 E3	F241 G3
2231 F1	4214 E3	F242 G3
2232 F1	4215 G3	F243 G3
2233 F12	4217 G3	F244 H3
2234 G1	4218 G3	F245 H3
2235 G1	4219 G3	F246 H3
2236 E1	4220 E6	F247 H3
2237 E1	4221 D9	F248 H3
2238 H8	4222 D9	F249 I3
2239 D8	4223 D9	F250 B11
2240 H1	4224 E9	F251 B11
2241 H1	4225 E9	F252 B11
2242 G5	4226 E9	F253 B11
2243 G8	4227 F9	F254 B11
2244 G9	4228 E10	F255 B11
2245 E9	4229 E8	F256 B11
2246 E10	4230 E8	F257 B11
2247 E11	4231 G9	F258 B11
2248 G12	4234 I9	F259 D11
2249 H10	4242 H13	F260 D11
2250 H9	4237 I12	F261 D11
2251 G13	4239 H12	F262 D11
2252 H13	4240 H12	F263 E12
2253 I7	4241 H3	F264 A12
2254 H10	4242 H13	F265 G13
2255 H9	4243 E9	F266 A6
2256 A8	4244 C11	F267 G6
2257 G6	4245 E8	
2258 G9	4246 E8	
2259 G12	4247 G3	
2260 H7	4249 G10	
2263 I7	4250 G10	
2268 D12	4251 C9	
2269 D12	4253 D9	
2270 C12	4254 D8	
2271 D12	4255 E10	
2272 D12	4257 A11	
2273 A12	4258 A11	
2276 I2	4259 A11	
2278 D9	4260 A11	
2279 D9	4261 F7	
2280 E9	4262 F8	
2281 E10	5201 D1	
2282 E9	5202 F1	
2283 E9	5203 E1	
2284 E9	5204 G1	
3201 D1	5205 F1	
3202 D1	5206 H1	
3203 F1	5207 A6	
3204 F1	5208 C4	
3206 E1	5209 H8	
3207 E1	5210 H9	
3208 G1	5211 A1	
3209 G1	5212 G5	
3210 F1	5213 G8	
3211 F1	5214 G12	
3212 H1	5215 H13	
3213 H1	6201 F7	
3214 G6	6202 F7	
3215 G7	6203 F7	
3216 H6	6204 F12	
3217 H7	6205 I2	
3218 I7	6206 I2	
3219 I7	7201 G7	
3220 C5	7202 G7	
3221 C6	7203 H8	
3222 D2	7205 A5	
3223 F2	7206 B3	
3224 F2	7207 C4	
3225 G2	7208 F9	
3226 E2	7209 F9	
3227 H2	7210 F11	
3228 H10	7211 H12	
3229 H10	7212 A9	
3230 I9	7214 B9	

★ Components having special characteristics are marked and must be replaced with parts having specifications equal to those originally installed.
 ● 印のある部品は、安全性確保部品を示しています。部品の交換が必要な場合、パーツリストに記載されている部品を使用してください。
 ★ Schematic diagram is subject to change without notice. ● 本回路図は標準回路図です。改良のため予告なく変更することがございます。

The first digit of a component indicates the component type.

1xxx : Connector 3xxx : Resistor 5xxx : Coil 7xxx : IC, Transistor, FET
2xxx : Capacitor 4xxx : SMD jumper 6xxx : Diode 9xxx : Wire jumper

AV 1/2 1 2 3 4 5 6 7 8 9 10 11 12

A A B B C C D D E E F F G G H H

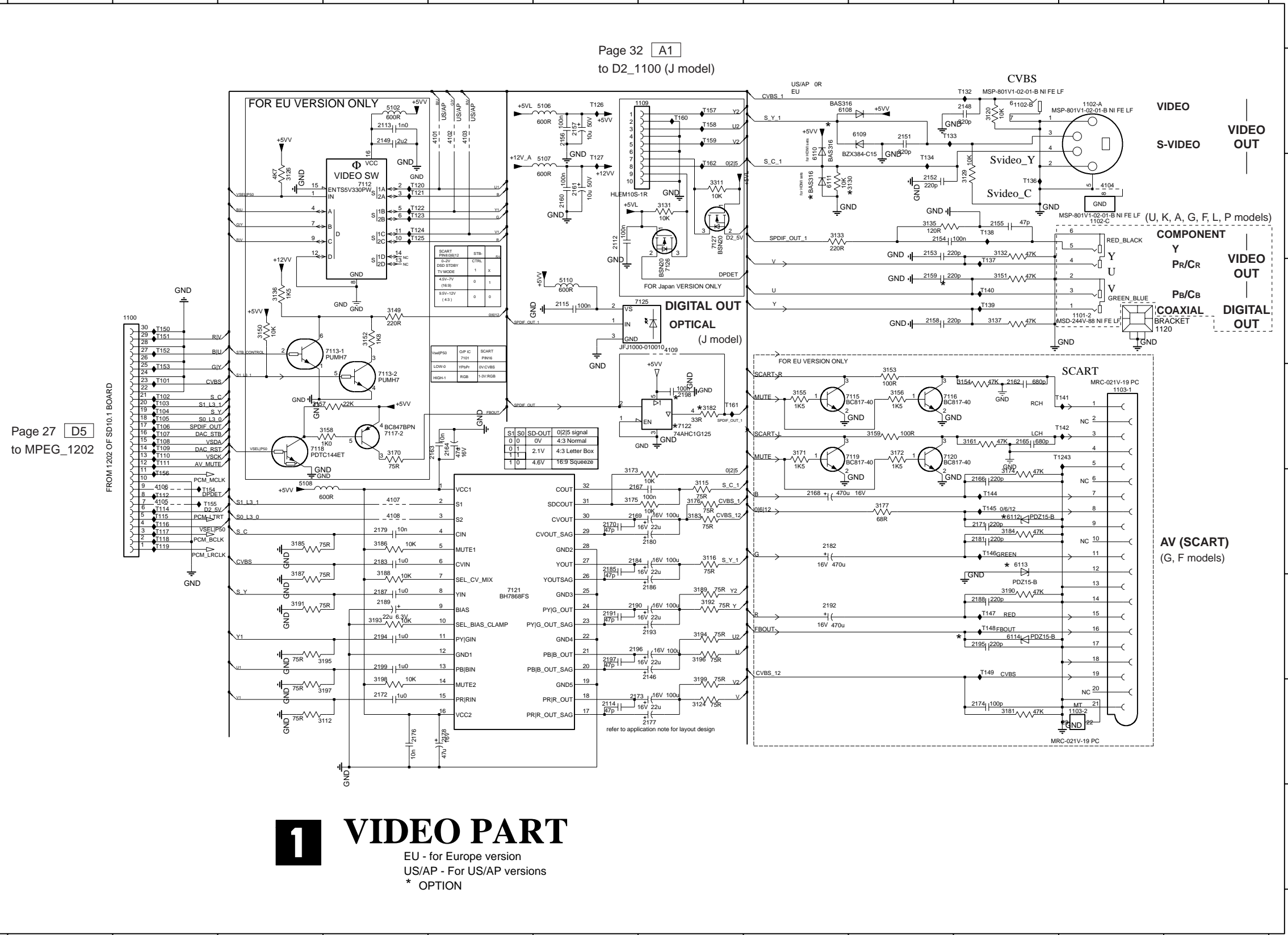

Page 32 A1
to D2_1100 (J model)

Page 27 D5
to MPEG_1202

1 VIDEO PART

EU - for Europe version
US/AP - For US/AP versions
* OPTION

- 1100 C2 3193 F4
- 1101-2 C11 3194 F7
- 1102-A A11 3195 F4
- 1102-B A10 3196 F7
- 1102-C B11 3197 G4
- 1103-1 D11 3198 G4
- 1103-2 G11 3199 G7
- 1109 A7 3311 B7
- 1120 C11 4101 A5
- 2112 B6 4102 A5
- 2113 A4 4103 A5
- 2114 G6 4104 B11
- 2115 C6 4105 E2
- 2146 F7 4106 E2
- 2148 A10 4107 E4
- 2149 A4 4108 E4
- 2151 A9 4109 C7
- 2152 B9 5102 A4
- 2153 B9 5106 A6
- 2154 B9 5107 B6
- 2155 B10 5108 E3
- 2156 A6 5110 C6
- 2157 A6 6108 A8
- 2158 C9 6109 A9
- 2159 C9 6110 B8
- 2160 B6 6111 B8
- 2161 B6 6112 E0
- 2162 D10 6113 E10
- 2163 D5 6114 F10
- 2164 D5 7112 B4
- 2165 D10 7113-1 C4
- 2166 E10 7113-2 D4
- 2167 E6 7115 D8
- 2168 E8 7116 D9
- 2169 E6 7117-2 D4
- 2170 E6 7118 D3
- 2171 E10 7119 D8
- 2172 G4 7120 D9
- 2173 G6 7121 F5
- 2174 G10 7122 D7
- 2176 G4 7125 C7
- 2177 G7 7126 B7
- 2178 G5 7127 B7
- 2179 E4 7101 D2
- 2180 E7 7102 D2
- 2181 D10 7103 D2
- 2182 E8 7104 D2
- 2183 E4 7105 D2
- 2184 E6 7106 D2
- 2185 E6 7107 D2
- 2186 F7 7108 D2
- 2187 F4 7109 D2
- 2188 F10 7110 D2
- 2189 F4 7111 D2
- 2190 F6 7112 E2
- 2191 F6 7114 E2
- 2192 F8 7115 E2
- 2193 F7 7116 E2
- 2194 F4 7117 E2
- 2195 F10 7118 E2
- 2196 F6 7119 E2
- 2197 F6 7120 B4
- 2198 D7 7121 B4
- 2199 F4 7122 B4
- 3112 G4 7123 B4
- 3115 E7 7124 B4
- 3116 E7 71245 D11
- 3120 A10 7125 B4
- 3124 G7 7126 A6
- 3126 B3 7127 B6
- 3129 B10 7132 A10
- 3130 B8 7133 A9
- 3131 B7 7134 B9
- 3132 B10 7136 B10
- 3133 B8 7137 C10
- 3135 B9 7138 B10
- 3136 C3 7139 C10
- 3137 C10 7140 C10
- 3149 C4 7141 D11
- 3150 C3 7142 D11
- 3151 C10 7144 E10
- 3152 C4 7145 E10
- 3153 D9 7146 E10
- 3154 D10 7147 F10
- 3155 D8 7148 F10
- 3156 D9 7149 F10
- 3157 D3 7150 C2
- 3158 D4 7151 C2
- 3159 D9 7152 C2
- 3161 D10 7153 D2
- 3170 D4 7154 E2
- 3171 D8 7155 E2
- 3172 D9 7156 E2
- 3173 E6 7157 A7
- 3174 E10 7158 A7
- 3175 E6 7159 A7
- 3176 E7 7160 A7
- 3177 E9 7161 D7
- 3181 G10 7162 B7
- 3182 D7 7162 B7
- 3183 E7 7162 B7
- 3184 E10 7162 B7
- 3185 E3 7162 B7
- 3186 E4 7162 B7
- 3187 E3 7162 B7
- 3188 F4 7162 B7
- 3189 F7 7162 B7
- 3190 F10 7162 B7
- 3191 F3 7162 B7
- 3192 F7 7162 B7

★ Components having special characteristics are marked with a triangle and must be replaced with parts having specifications equal to those originally installed.
● 印のある部品は、安全性確保部品を示しています。部品の交換が必要な場合、パーツリストに記載されている部品を使用してください。
★ Schematic diagram is subject to change without notice. ● 本回路図は標準回路図です。改良のため予告なく変更することがございます。

The first digit of a component indicates the component type.

1xxx : Connector 3xxx : Resistor 5xxx : Coil 7xxx : IC, Transistor, FET
 2xxx : Capacitor 4xxx : SMD jumper 6xxx : Diode 9xxx : Wire jumper

AV 2/2

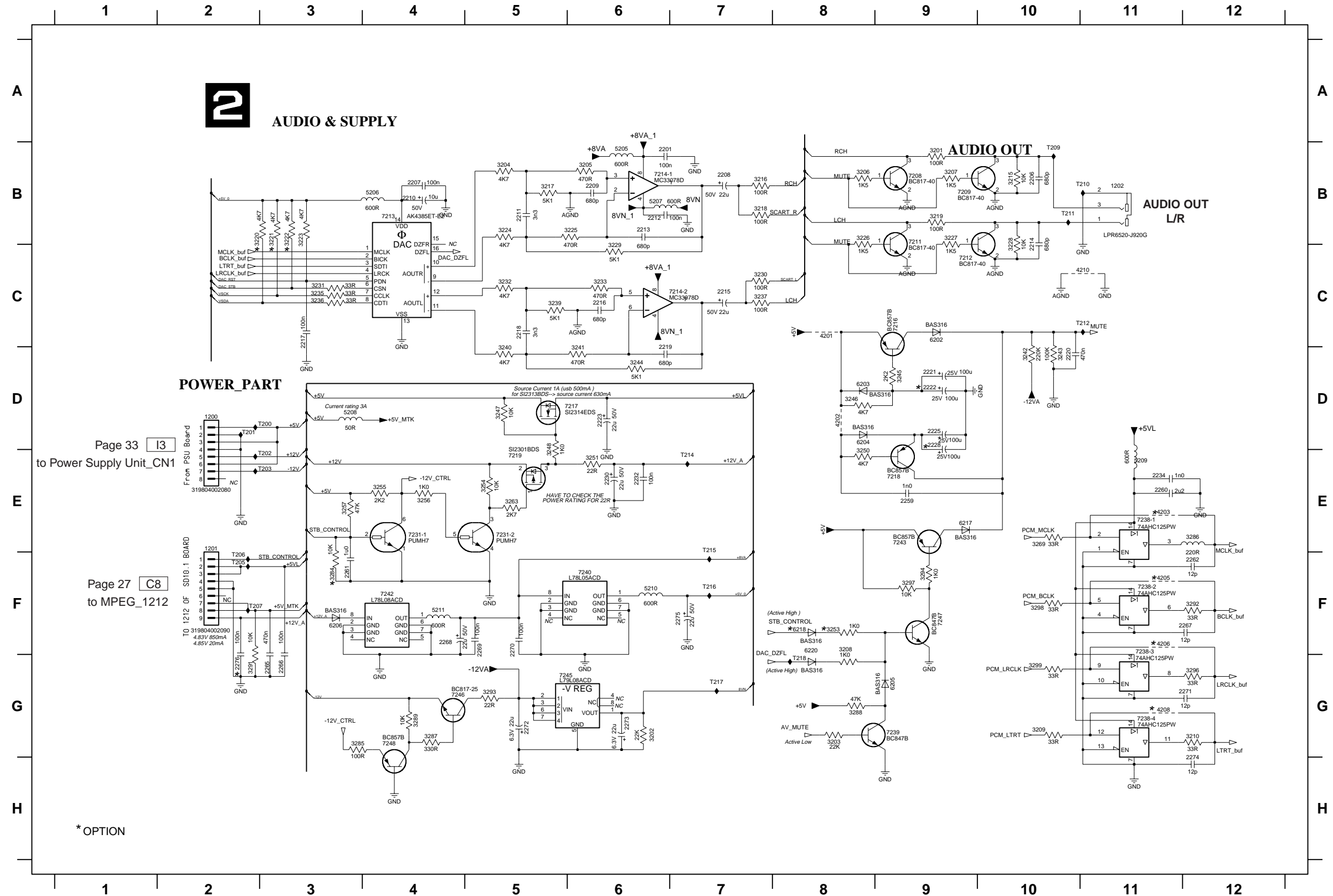

1200 D2	3289 G4
1201 E2	3291 G2
1202 B11	3292 F12
2201 B6	3293 G5
2206 B10	3294 F9
2207 B4	3296 G12
2208 B7	3297 F9
2209 B6	3298 F10
2210 B4	3299 G10
2211 B5	4201 C8
2212 B6	4202 D8
2213 B6	4203 E11
2214 B10	4205 F11
2215 C7	4206 F11
2216 C6	4208 G11
2217 C3	4210 C11
2218 C5	5205 B6
2219 D6	5206 B4
2220 D10	5207 B6
2221 D9	5208 D3
2222 D9	5209 E11
2223 D6	5210 F6
2225 D9	5211 F4
2228 D9	6202 C9
2230 E6	6203 D8
2232 E6	6204 D8
2234 E11	6205 G9
2259 E9	6206 F3
2260 E11	6217 E9
2261 F3	6218 F8
2262 F12	6220 F8
2265 G3	7208 B9
2266 G3	7209 B9
2267 F12	7211 B9
2268 F4	7212 C9
2269 F5	7213 B4
2270 F5	7214-1 B6
2271 G12	7214-2 C6
2272 G5	7216 C9
2273 G6	7217 D5
2274 H12	7218 E9
2275 F7	7219 E5
2276 G2	7231-1 E4
3201 B9	7231-2 E5
3202 G6	7238-1 E11
3203 G8	7238-2 F11
3204 B5	7238-3 F11
3205 B6	7238-4 G11
3206 B8	7239 G9
3207 B9	7240 F6
3208 F8	7242 F4
3209 G10	7243 E9
3210 G12	7245 G6
3215 B10	7246 G4
3216 B7	7247 F9
3217 B5	7248 G4
3218 B7	T200 D3
3219 B9	T201 D2
3220 B2	T202 E3
3221 B3	T203 E3
3222 B3	T205 F2
3223 B3	T206 F2
3224 B5	T207 F2
3225 B6	T209 B10
3226 B8	T210 B11
3227 B9	T211 B10
3228 B10	T212 C11
3229 C6	T214 E7
3230 C7	T215 E7
3231 C3	T216 F7
3232 C5	T217 G7
3233 C6	T218 G8
3235 C3	
3237 C7	
3239 C5	
3240 D5	
3241 D6	
3242 D10	
3243 D10	
3244 D6	
3245 D9	
3246 D8	
3247 D5	
3248 D5	
3250 E8	
3251 E6	
3253 F8	
3254 E5	
3255 E4	
3256 E4	
3257 E3	
3263 E5	
3269 E10	
3284 F3	
3285 G3	
3286 E12	
3287 G4	
3288 G8	

★ Components having special characteristics are marked Δ and must be replaced with parts having specifications equal to those originally installed.
 ★ Schematic diagram is subject to change without notice.

● Δ 印のある部品は、安全性確保部品を示しています。部品の交換が必要な場合、パーツリストに記載されている部品を使用してください。
 ● 本回路図は標準回路図です。改良のため予告なく変更することがございます。

FRONT 1/2

The first digit of a component indicates the component type.

1xxx : Connector 3xxx : Resistor 5xxx : Coil 7xxx : IC, Transistor, FET
 2xxx : Capacitor 4xxx : SMD jumper 6xxx : Diode 9xxx : Wire jumper

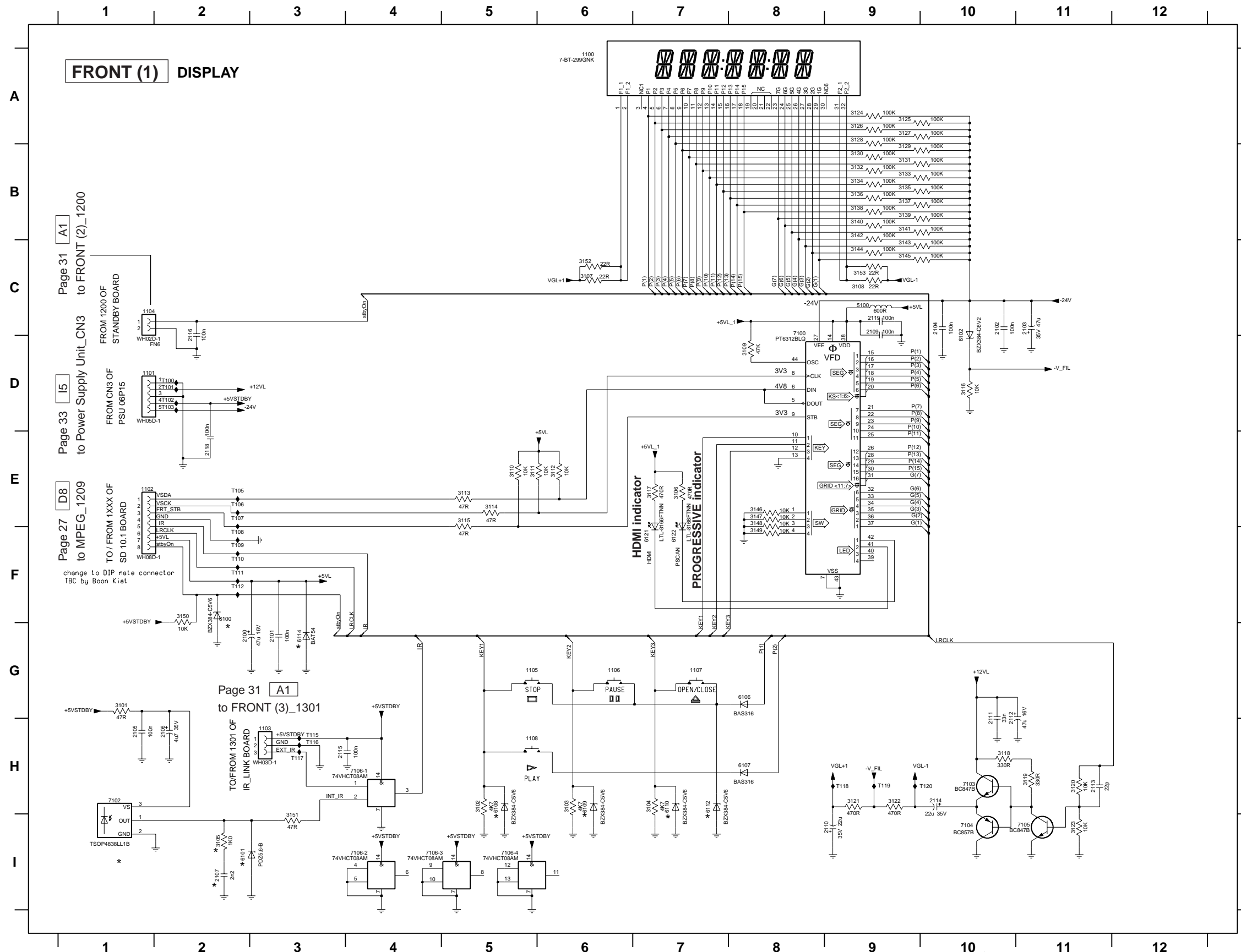

1100 A6	T112 F2
1101 D1	T115 H3
1102 E1	T116 H3
1103 H3	T117 H3
1104 C1	T118 H9
1105 G5	T119 H9
1106 G6	T120 H10
1107 G7	
1108 H5	
2100 G2	
2101 G3	
2102 C10	
2103 C11	
2104 C10	
2105 H1	
2106 H2	
2107 I2	
2109 C9	
2110 I9	
2111 G10	
2112 G10	
2113 H11	
2114 H10	
2115 H3	
2116 C2	
2118 E2	
2119 C9	
3101 G1	
3102 H5	
3103 H6	
3104 H7	
3105 I2	
3106 F7	
3107 C6	
3108 C9	
3109 D8	
3110 E5	
3111 E5	
3112 E5	
3113 E5	
3114 E5	
3115 E5	
3116 D10	
3117 E7	
3118 H10	
3119 H11	
3120 H11	
3121 H9	
3122 H9	
3123 I1	
3124 A9	
3125 A9	
3126 A9	
3127 A9	
3128 A9	
3129 B9	
3130 B9	
3131 B9	
3132 B9	
3133 B9	
3134 B9	
3135 B9	
3136 B9	
3137 B9	
3138 B9	
3139 B9	
3140 B9	
3141 B9	
3142 B9	
3143 C9	
3144 C9	
3145 C9	
3146 E8	
3147 E8	
3148 E8	
3149 F8	
3150 F2	
3151 I3	
3152 C6	
3153 C9	
5100 C9	
6100 F2	
6101 I2	
6102 C10	
6106 G8	
6107 H8	
6108 H5	
6109 H6	
6110 H7	
6112 H7	
6114 G3	
6121 F7	
6122 F7	
7100 C8	
7102 H1	
7103 H10	
7104 H10	
7105 H11	
7106-1 H4	
7106-2 I4	
7106-3 I5	
7106-4 I5	
T100 D2	
T101 D2	
T102 D2	
T103 D2	
T105 E2	
T106 E2	
T107 E2	
T108 F2	
T109 F2	
T110 F2	
T111 F2	

★ Components having special characteristics are marked Δ and must be replaced with parts having specifications equal to those originally installed.
 ★ Schematic diagram is subject to change without notice.

● Δ 印のある部品は、安全性確保部品を示しています。部品の交換が必要な場合、パーツリストに記載されている部品を使用してください。
 ● 本回路図は標準回路図です。改良のため予告なく変更することがございます。

FRONT 2/2

The first digit of a component indicates the component type.

- 1xxx : Connector 3xxx : Resistor 5xxx : Coil 7xxx : IC, Transistor, FET
- 2xxx : Capacitor 4xxx : SMD jumper 6xxx : Diode 9xxx : Wire jumper

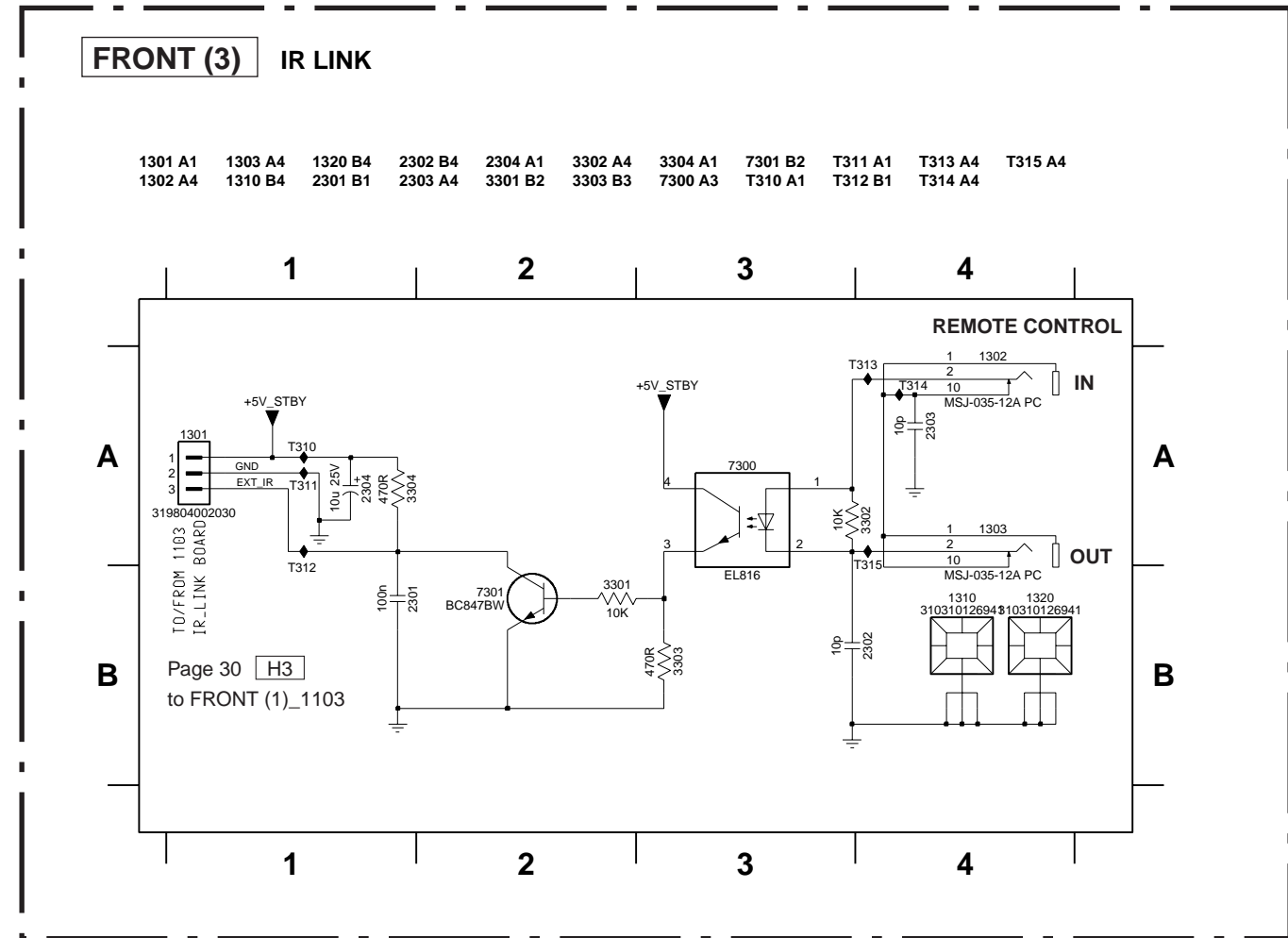
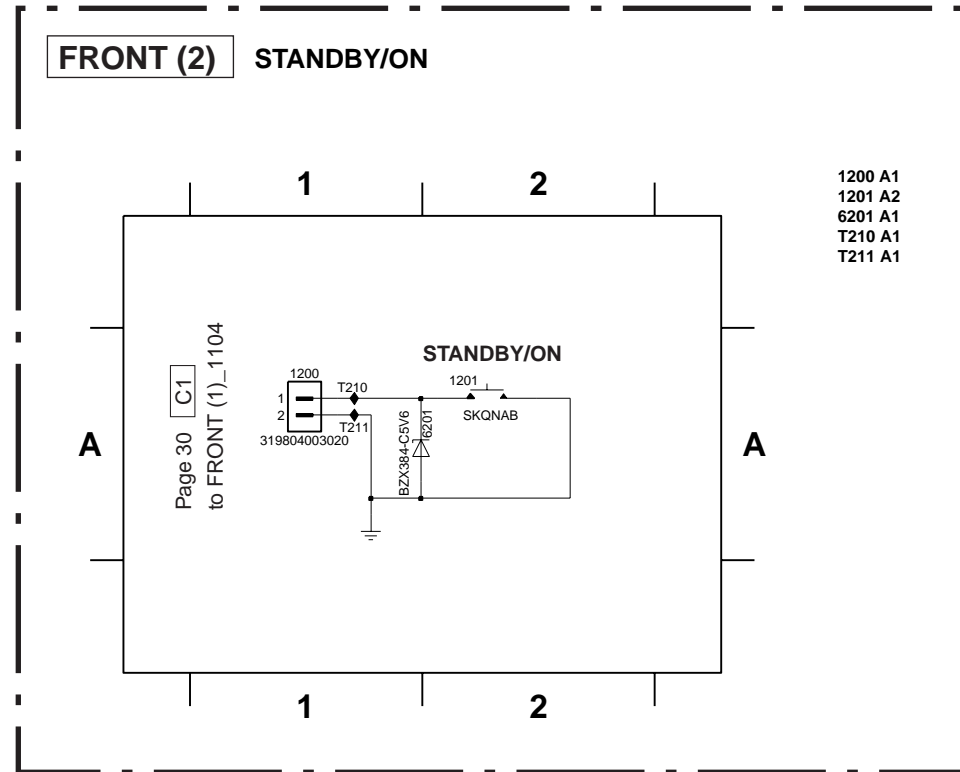

★ Components having special characteristics are marked and must be replaced with parts having specifications equal to those originally installed.
★ Schematic diagram is subject to change without notice.

● 印のある部品は、安全性確保部品を示しています。部品の交換が必要な場合、パーツリストに記載されている部品を使用してください。
● 本回路図は標準回路図です。改良のため予告なく変更することがございます。

D2 (J model)

The first digit of a component indicates the component type.

1xxx : Connector 3xxx : Resistor 5xxx : Coil 7xxx : IC, Transistor, FET
 2xxx : Capacitor 4xxx : SMD jumper 6xxx : Diode 9xxx : Wire jumper

1100 A1 2101 B3 2103 B3 6101 B2 6103 B3 T102 A1 T104 A1 T106 A1
 1101 A4 2102 B3 3101 B3 6102 B3 T101 A1 T103 A1 T105 A1 T107 A1

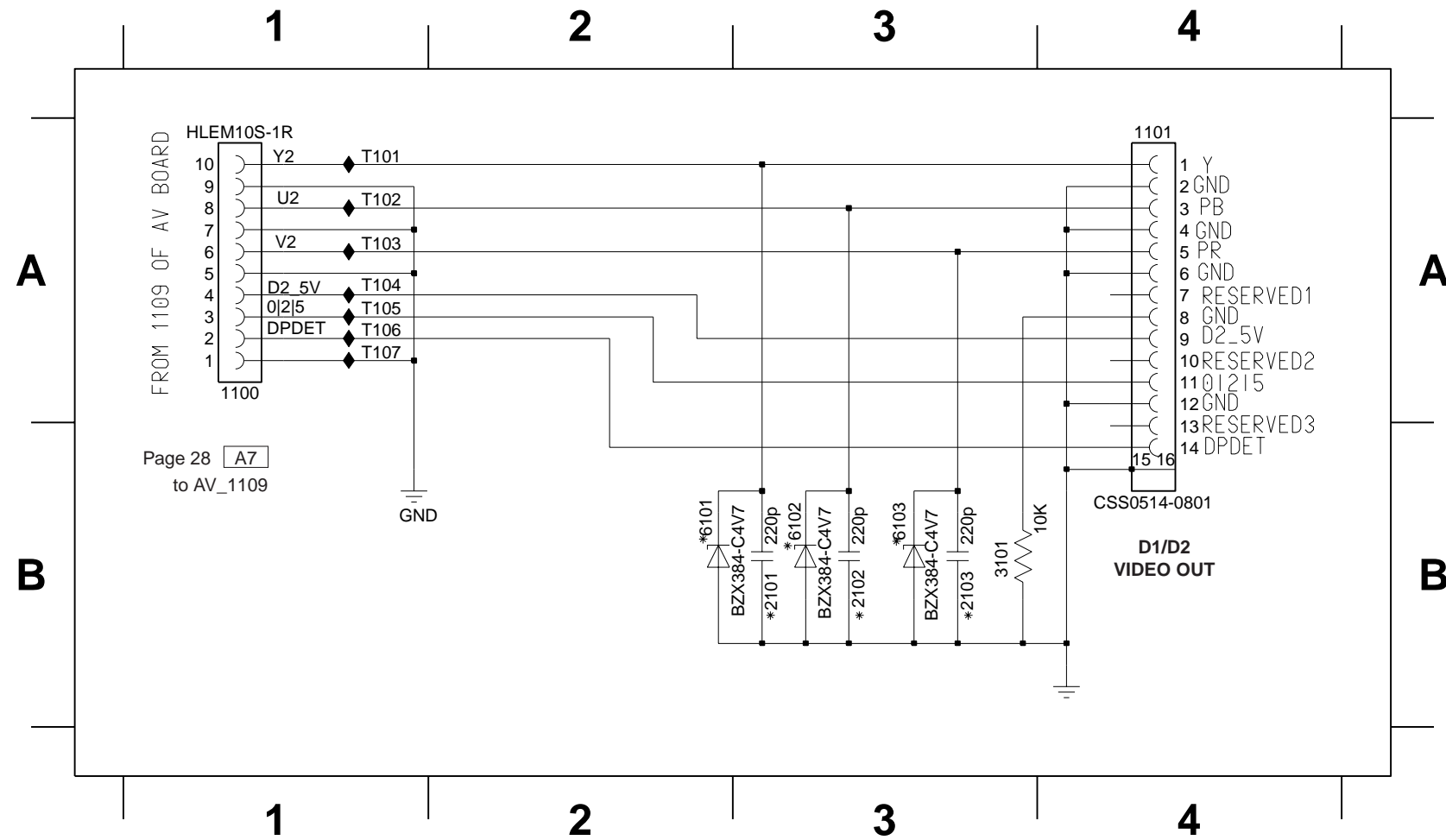

Page 28 A7
 to AV_1109

★ Components having special characteristics are marked ▲ and must be replaced with parts having specifications equal to those originally installed.
 ★ Schematic diagram is subject to change without notice.

● ▲印のある部品は、安全性確保部品を示しています。部品の交換が必要な場合、パーツリストに記載されている部品を使用してください。
 ● 本回路図は標準回路図です。改良のため予告なく変更することがございます。

POWER SUPPLY UNIT

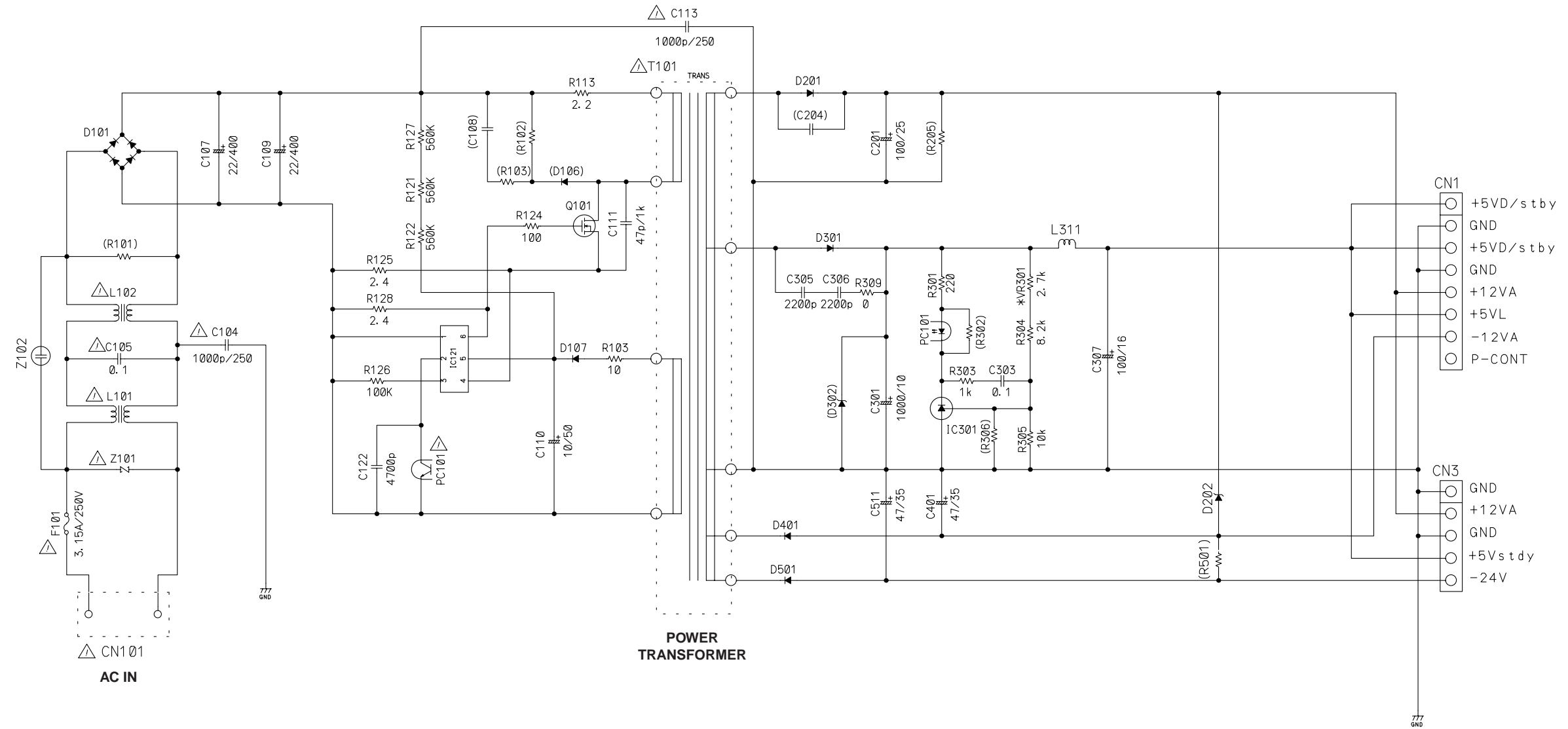

Page 29 **D2**
to AV_1200

Page 30 **D1**
to FRONT (1)_1101

D101	D1UBA80	D201, D401	PR1003, RGP10D
D107	PR1003, RGP10D	D202	MTZ30, MA4300
IC121	SG6848	D301	SB560, RK46
Q101	FQI2N80	D501	PR1005, RGP10J
PC101	LTV-817M, PC123, PS2561	IC301	TL431, MM1431A

★ Components having special characteristics are marked and must be replaced with parts having specifications equal to those originally installed.
★ Schematic diagram is subject to change without notice.

● 印のある部品は、安全性確保部品を示しています。部品の交換が必要な場合、パーツリストに記載されている部品を使用してください。
● 本回路図は標準回路図です。改良のため予告なく変更することがございます。

REPLACEMENT PARTS LIST

OVERALL ASS'Y

When disassembling, use the special screw driver with such tip shape as shown in figure.

分解には図のような特殊ドライバーを使用します。

T10 2.7 mm

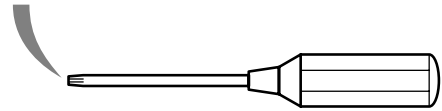

250 3 x 8 P-Tight Black

256 3 x 6 S-Tight Black

267 3 x 6 S-Tight with the brim

3 x 15 S-Tight Black
(No replacement part available. / サービス部品供給なし)

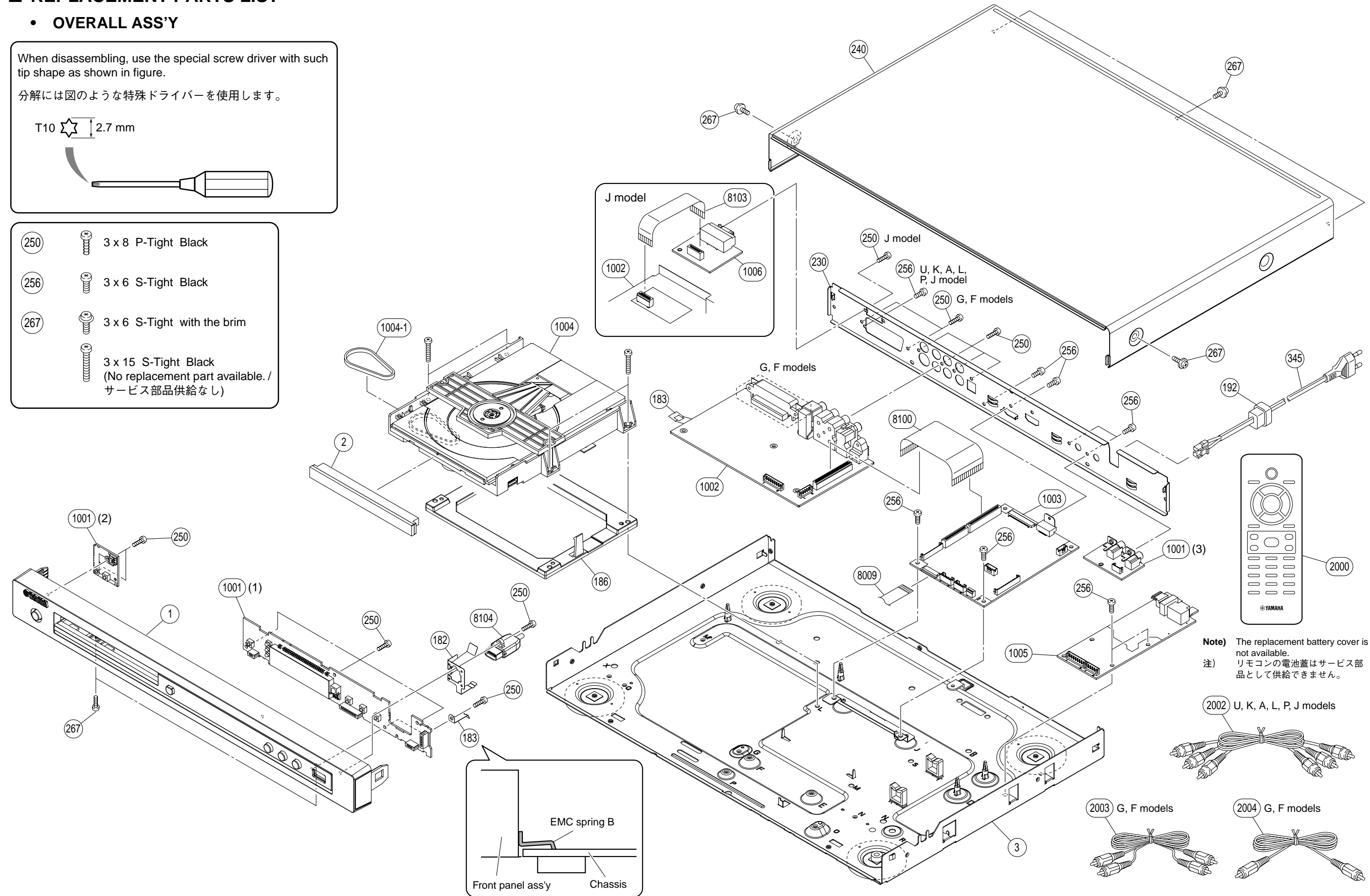

Note) The replacement battery cover is not available.
注) リモコンの電池蓋はサービス部品として供給できません。

2002 U, K, A, L, P, J models

2003 G, F models

2004 G, F models

■ WARNING

- Components having special characteristics are marked △ and must be replaced with parts having specifications equal to those originally installed.
- △印のある部分は、安全確保部品を示しています。部品の交換が必要な場合、パーツリストに記載されている部品を使用してください。

Ref No.	Part No.	Description	Remarks	Markets	部 品 名	ランク		
*	1	AAX90480	FRONT PANEL ASS'Y	GD	3141 079 45891		フロントパネルASSY	
*	1	AAX90450	FRONT PANEL ASS'Y	663BL	3141 079 45861		フロントパネルASSY	
*	1	AAX90490	FRONT PANEL ASS'Y	6165BL	3141 079 45901		フロントパネルASSY	
*	1	AAX90470	FRONT PANEL ASS'Y	TI	3141 079 45881		フロントパネルASSY	
*	1	AAX90460	FRONT PANEL ASS'Y	SI	3141 079 45871		フロントパネルASSY	
*	2	AAX77810	TRAY COVER ASS'Y		3141 079 37091		トレイカバーASSY	
*	3	AAX90430	FRAME ASS'Y		3141 079 45911	J	フレームASSY	
*	3	AAX90440	FRAME ASS'Y		3141 079 45921	UKAGFLP	フレームASSY	
*	182	AAX90410	SPRING EMC USB		3139 241 28121		スプリングEMC USB	
*	183	AAX90400	SPRING EMC B		3139 241 00043		スプリングEMC B	
*	186	AAX77860	BRACKET		3139 244 10241		ブラケット	
*	192	AAX53540	BUSHING		3139 114 26671		ブッシュ	
*	230	AAX90510	REAR PANEL		3139 241 28041	J	リアパネル	
*	230	AAX90570	REAR PANEL	663	3139 241 28101	U	リアパネル	
*	230	AAX90500	REAR PANEL	6165	3139 241 28031	U	リアパネル	
*	230	AAX90530	REAR PANEL		3139 241 28061	K	リアパネル	
*	230	AAX90550	REAR PANEL		3139 241 28081	A	リアパネル	
*	230	AAX90580	REAR PANEL		3139 241 28111	G	リアパネル	
*	230	AAX90560	REAR PANEL		3139 241 28091	F	リアパネル	
*	230	AAX90540	REAR PANEL		3139 241 28071	L	リアパネル	
*	230	AAX90520	REAR PANEL		3139 241 28051	P	リアパネル	
*	240	AAX90420	TOP COVER	GD	3139 241 27971		トップカバー	
*	240	AAX58270	TOP COVER	BL	3139 247 59051		トップカバー	
*	240	AAX58291	TOP COVER	TI	3139 241 22192		トップカバー	
*	240	AAX88000	TOP COVER	SI	3139 241 27262		トップカバー	
*	250	AAX53520	PAN HEAD TORX P-TIGHT SCREW	3x8 MFZN2BL	2511 076 50012		ナバトルクスPタイトネジ	
*	256	AAX23640	PAN HEAD TORX S-TIGHT SCREW	3x6 MFZN2BL	2511 077 00039		ナバトルクスSタイトネジ	
*	267	AAX57730	PW HEAD TORX S-TIGHT SCREW	GD 3x6 MFN133	3103 301 45951		PWヘッドSタイトネジ	01
*	267	AAX55450	PW HEAD TORX S-TIGHT SCREW	BL 3x6 MFZN2BL	3139 110 40611		PWヘッドSタイトネジ	
*	267	AAX53440	PW HEAD TORX S-TIGHT SCREW	TI,SI 3x6 MFN133	3104 120 40081		PWヘッドSタイトネジ	
△	345	AAX53650	POWER CABLE	1.8m	2422 070 98255	J	電源コード	05
△	345	AAX47750	POWER CABLE	1.8m	2422 070 98235	UA	電源コード	
△	345	AAX59130	POWER CABLE	1.8m	2422 070 98222	K	電源コード	
△	345	AAX53630	POWER CABLE	1.8m	2422 070 98231	GFL	電源コード	
△	345	AAX82310	POWER CABLE	1.8m	2422 070 00026	P	電源コード	
*	1001	AAX90350	P.C.B. ASS'Y	FRONT	3139 248 54251		PCB FRONT	
*	1002	AAX90330	P.C.B. ASS'Y	AV	3139 248 54331	J	PCB AV	
*	1002	AAX90310	P.C.B. ASS'Y	AV	3139 248 54201	UKALP	PCB AV	
*	1002	AAX90320	P.C.B. ASS'Y	AV	3139 248 54211	GF	PCB AV	
*	1003	AAX90370	P.C.B. ASS'Y	MPEG SD10.1 AP	3139 248 54501	JKL	PCB MPEG	
*	1003	AAX90360	P.C.B. ASS'Y	MPEG SD10.1	3139 248 54271	UAGFP	PCB MPEG	
*	1004	AAX90590	LOADER ASS'Y	WXD-8829C	3139 247 14231		ローダーASSY	
*	1004-1	AAX90090	BELT LOADING				ローディングベルト	01
△	1005	AAX79050	POWER SUPPLY UNIT	SRV1919WW	3139 247 13351		電源ユニット	
*	1006	AAX90340	P.C.B. ASS'Y	D2	3139 248 54261	J	PCB D2	
*	8009	AAX53460	FLEXIBLE FLAT CABLE	24P 280mm P=0.5	3139 241 00391		カード電線	05
*	8100	AAX77800	FLEXIBLE FLAT CABLE	30P 60mm P=1.25	3139 241 02491		カード電線	
*	8103	AAX90380	FLEXIBLE FLAT CABLE	10P 80mm P=1.25	3139 241 03391	J	カード電線	
*	8104	AAX89290	USB CABLE ASS'Y	USB 5P 300mm	2422 076 00786		USBケーブルASSY	05
*	2000	AAX83650	ACCESSORIES				付属品	
*	2002	AAX90600	REMOTE CONTROL	DVD-16	2422 549 01589		リモコン	
*	2003	AAX21980	AUDIO/VIDEO CABLE	YE/RD/WH 1.5m 1pc	2422 076 00718	JUKALP	音声/映像ピンケーブル	
*	2004	AAX22970	AUDIO PIN CABLE	RE/WH 1.5m 1pc	3103 308 92611	GF	ステレオピンケーブル	
*	2004	AAX22970	VIDEO PIN CABLE	YE 1.5m 1pc	3104 108 45432	GF	ビデオ用ピンケーブル	
*	2004	AAX22970	BATTERY	R03, AAA, UM-4 2pcs			単4乾電池	

* New Parts * 新規部品

■ REMOTE CONTROL

• PANEL

DVD-16

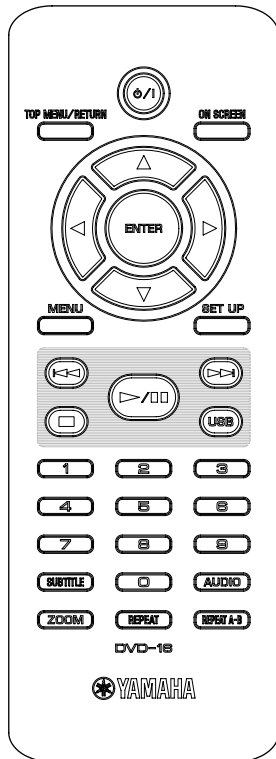

• KEY NO. LAYOUT

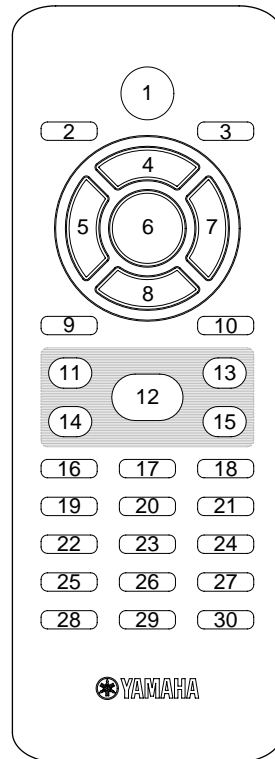

• KEY CODE

No.	Key label	Code
1	STANDBY (POWER)	7C-80
2	TOP MENU/RETURN	7C-B1
3	ON SCREEN	7C-A6
4	▲ (UP)	7C-B4
5	◀ (LEFT)	7C-B5
6	ENTER	7C-B8
7	▶ (RIGHT)	7C-B6
8	▼ (DOWN)	7C-B3
9	MENU	7C-B2
10	SET UP	7C-AC
11	◀◀ (SKIP) / SEARCH-	7C-B9
12	▶/ (PLAY/PAUSE) *	7C-92
13	▶▶ (SKIP) / SEARCH+	7C-BA
14	■ (STOP)	7C-85
15	USB	7C-E6
16	1	7C-94
17	2	7C-95
18	3	7C-96
19	4	7C-97
20	5	7C-98
21	6	7C-99
22	7	7C-9A
23	8	7C-9B
24	9	7C-9C
25	SUBTITLE	7C-AA
26	0	7C-93
27	AUDIO	7C-AD
28	ZOOM	7C-D7
29	REPEAT	7C-A3
30	REPEAT A-B	7C-A4

* Possible receiving
 PLAY : 7C-82
 PAUSE : 7C-83

DVD-S663/DV-S6165

