

AV RECEIVER HTR-5635

SERVICE MANUAL

For U, C models

IMPORTANT NOTICE

This manual has been provided for the use of authorized YAMAHA Retailers and their service personnel. It has been assumed that basic service procedures inherent to the industry, and more specifically YAMAHA Products, are already known and understood by the users, and have therefore not been restated.

WARNING: Failure to follow appropriate service and safety procedures when servicing this product may result in personal injury, destruction of expensive components, and failure of the product to perform as specified. For these reasons, we advise all YAMAHA product owners that any service required should be performed by an authorized YAMAHA Retailer or the appointed service representative.

IMPORTANT: The presentation or sale of this manual to any individual or firm does not constitute authorization, certification or recognition of any applicable technical capabilities, or establish a principle-agent relationship of any form.

The data provided is believed to be accurate and applicable to the unit(s) indicated on the cover. The research, engineering, and service departments of YAMAHA are continually striving to improve YAMAHA products. Modifications are, therefore, inevitable and specifications are subject to change without notice or obligation to retrofit. Should any discrepancy appear to exist, please contact the distributor's Service Division.

WARNING: Static discharges can destroy expensive components. Discharge any static electricity your body may have accumulated by grounding yourself to the ground buss in the unit (heavy gauge black wires connect to this buss).

IMPORTANT: Turn the unit OFF during disassembly and part replacement. Recheck all work before you apply power to the unit.

■ CONTENTS

TO SERVICE PERSONNEL	2	AMP ADJUSTMENT	26
IMPEDANCE SELECTOR	2	DISPLAY DATA	27~28
FRONT PANEL	3	IC DATA	29~34
REAR PANEL	3	BLOCK DIAGRAM	35~36
REMOTE CONTROL	3	PRINTED CIRCUIT BOARD	37~46
SPECIFICATIONS	4~5	PIN CONNECTION DIAGRAM	47~48
INTERNAL VIEW	6	SCHEMATIC DIAGRAM	49~54
DISASSEMBLY PROCEDURES	7~9	PARTS LIST	55~65
SELF DIAGNOSIS FUNCTION (DIAG)	10~26	REMOTE CONTROL	66~67



このサービスマニュアルは、エコマーク認定の再生紙を使用しています。
This Service Manual uses recycled paper.

100849

Copyright 2003 YAMAHA CORPORATION □
This manual is copyrighted by YAMAHA and may not be copied or □
redistributed either in print or electronically without permission. □



YAMAHA
YAMAHA CORPORATION
P.O.Box 1, Hamamatsu, Japan

HTR-5635

■ TO SERVICE PERSONNEL

1. Critical Components Information
Components having special characteristics are marked  and must be replaced with parts having specifications equal to those originally installed.
 2. Leakage Current Measurement (For 120V Models Only)
When service has been completed, it is imperative to verify that all exposed conductive surfaces are properly insulated from supply circuits.
- Meter impedance should be equivalent to 1500 ohm shunted by 0.15μF.

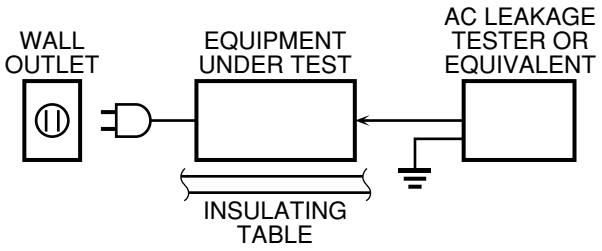

- Leakage current must not exceed 0.5mA.
- Be sure to test for leakage with the AC plug in both polarities.



“CAUTION”

“F922: FOR CONTINUED PROTECTION AGAINST RISK OF FIRE, REPLACE ONLY WITH SAME TYPE 7A, 125V FUSE.”

CAUTION

F922: REPLACE WITH SAME TYPE 7A, 125V FUSE.

ATTENTION

F922: UTILISER UN FUSIBLE DE RECHANGE DE MEME TYPE DE 7A, 125V.

WARNING: CHEMICAL CONTENT NOTICE!

The solder used in the production of this product contains LEAD. In addition, other electrical/electronic and/or plastic (where applicable) components may also contain traces of chemicals found by the California Health and Welfare Agency (and possibly other entities) to cause cancer and/or birth defects or other reproductive harm.

DO NOT PLACE SOLDER, ELECTRICAL/ELECTRONIC OR PLASTIC COMPONENTS IN YOUR MOUTH FOR ANY REASON WHATSOEVER!

Avoid prolonged, unprotected contact between solder and your skin! When soldering, do not inhale solder fumes or expose eyes to solder/flux vapor!

If you come in contact with solder or components located inside the enclosure of this product, wash your hands before handling food.

■ IMPEDANCE SELECTOR

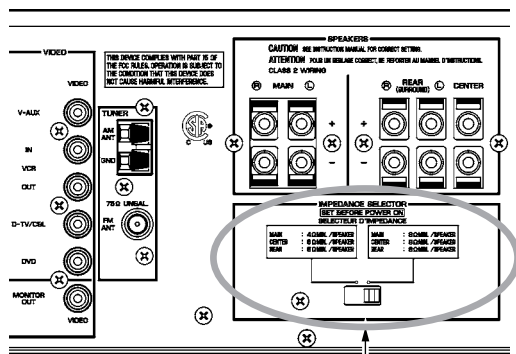

IMPEDANCE SELECTOR

WARNING:

Do not change the IMPEDANCE SELECTOR switch setting while the power to this unit is on, otherwise this unit may be damaged.

• DIMENSIONS

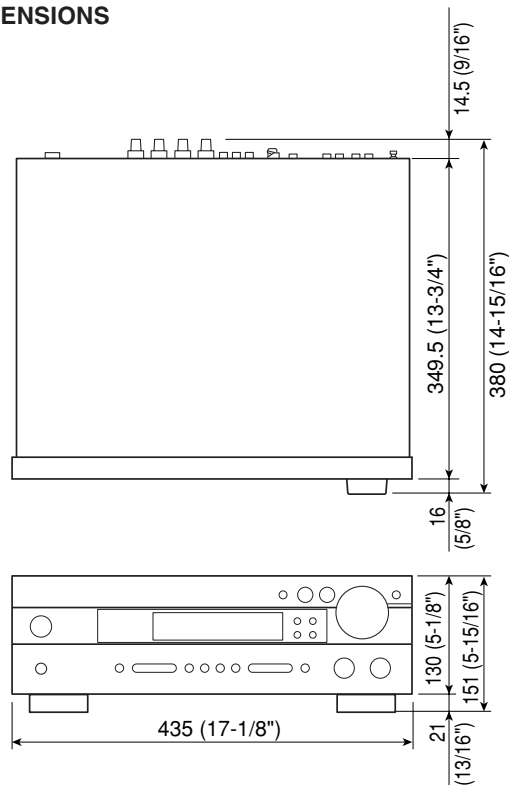

Unit : mm (inch)

HTR-5635

FRONT PANEL

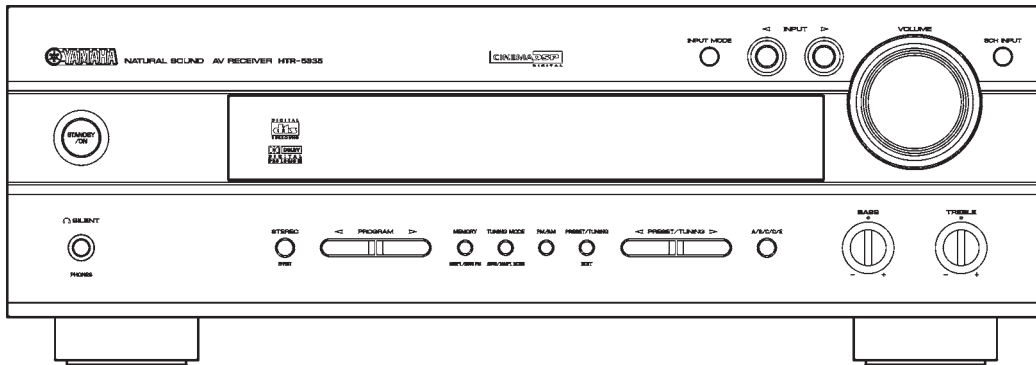

REAR PANEL

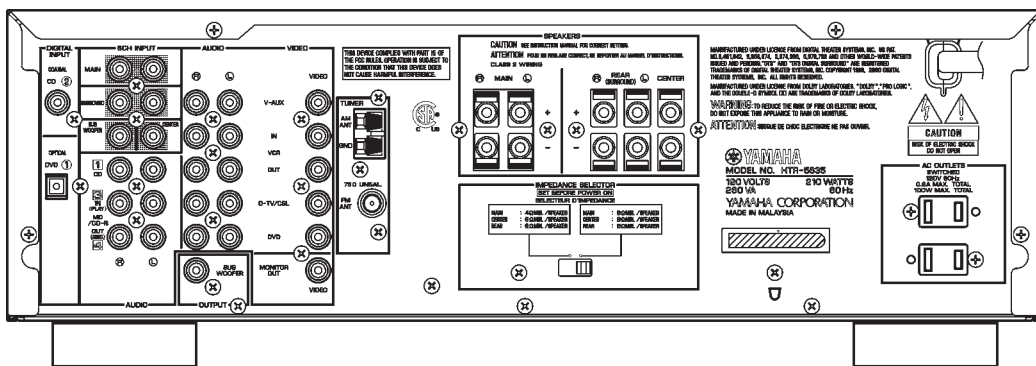

REMOTE CONTROL

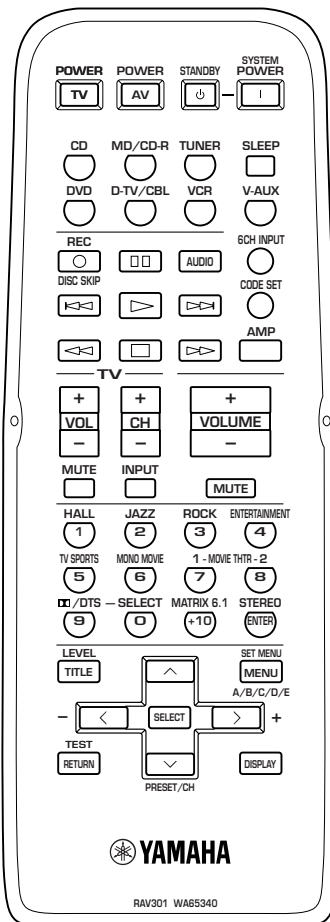

■ SPECIFICATIONS

■ Audio Section

Minimum RMS Output Power (Power Amp. Section)

(20 Hz to 20 kHz, 0.06% THD, 8 ohms)	
MAIN L/R	75W + 75W
CENTER	75W
REAR L/R	75W + 75W
(1 kHz, 0.09% THD, 8 ohms)	
MAIN L/R	85W + 85W
CENTER	85W
REAR L/R	85W + 85W

Dynamic Power Per Channel (IHF)

8/6/4/2 ohms	95/115/140/160W
--------------	-----------------

Damping Factor

20 Hz to 20 kHz, SPEAKER-A, 8 ohms	80 or more
------------------------------------	------------

Dynamic Headroom

8 ohms	1.09dB
--------	--------

Input Sensitivity / Input Impedance

CD, etc.	150 mV / 47 k-ohms
EXT. DECODER	
MAIN L/R, CENTER, SURROUND L/R, SUB WOOFER	150 mV / 47 k-ohms

Maximum Input Signal Level

(1 kHz, 0.5% THD, Effect On)	
CD, etc.	2.0V or more

Output Level / Output Impedance

REC OUT	150 mV / 1.2 k-ohms
SUB WOOFER (MAIN SP: Small)	4 V / 1.2 k-ohms

Headphone Jack Rated Output / Impedance

CD, etc. (1 kHz, 150 mV, 8 ohms)	0.34 V / 560 ohms
----------------------------------	-------------------

Frequency Response

CD, etc. to MAIN L/R (10 Hz to 100 kHz)	0/-3.0dB
---	----------

Total Harmonic Distortion

(20Hz to 20kHz, 40W, 8 ohms)	
CD, etc. (Effect Off) to MAIN L/R SP OUT	0.06% or less

Signal to Noise Ratio

CD, etc. (Input shorted, EFFECT OFF) to MAIN L/R	
250mV	100dB or more

Residual Noise (IHF-A network)

MAIN L/R SP OUT	150µV or less
-----------------	---------------

Channel Separation

(Vol -30 dB, Effect Off)	
CD, etc. (Input 5.1 k-ohms shorted, 1 kHz/10 kHz)	60 dB or more/45 dB or more

Tone Control Characteristics

BASS	
Boost/Cut	±10dB (50Hz)
Turnover Frequency	350Hz
TREBLE	
Boost/Cut	±10dB (20kHz)
Turnover Frequency	3.5kHz

Filter Characteristics

MAIN, REAR L/R SP Small (H.P.F.)	90Hz / 12dB oct.
SUBWOOFER (L.P.F.)	90Hz / 18dB oct.

■ Video Section

Video Signal Type

	NTSC
--	------

Video Signal Level

	1 Vp-p / 75 ohms
--	------------------

Maximum Input Level

	1.5 Vp-p or more
--	------------------

Signal to Noise Ratio

	50 dB or more
--	---------------

Monitor Out Frequency Response

Video Signal Level	5 Hz to 10 MHz, -3 dB
--------------------	-----------------------

■ FM Section

Tuning Range

	87.5 to 107.9 MHz
--	-------------------

50dB Quieting Sensitivity (IHF)

(1kHz, 100% Mod.)	
Mono	2.0 µV (17.3 dBf)
Stereo	25 µV (39.2 dBf)

Usable Sensitivity (IHF)

Mono	1.0 µV (11.2 dBf)
------	-------------------

Selectivity

at 400 kHz	70 dB
------------	-------

Signal to Noise Ratio (IHF)

Mono / Stereo	76 dB / 70 dB
---------------	---------------

Harmonic Distortion

(1 kHz)	
Mono/Stereo	0.2 / 0.3 %

Stereo Separation

1 kHz	45 dB
-------	-------

Frequency Response

20 Hz to 15 kHz	+0.5 / -2 dB
-----------------	--------------

Antenna Input

	75 ohms unbalanced
--	--------------------

■ AM Section

Tuning Range

	530 to 1,710 kHz
--	------------------

Usable Sensitivity

	300 µV/m
--	----------

Antenna

	Loop Antenna
--	--------------

■ General

Power Supply

	AC 120 V, 60 Hz
--	-----------------

Power Consumption

	210 W / 260 VA
--	----------------

Standby Power Consumption (reference data)

	0.6 W
--	-------

AC Outlets

2 switched outlets	100 W max. total
--------------------	------------------

Dimensions (W x H x D)

	435 x 151 x 387 mm (17-1/8" x 5-15/16" x 15-1/4")
--	---

Weight

	10.0 kg (22 lbs. 1 oz.)
--	-------------------------

Finish

	Black color
--	-------------

Accessories

	Remote Control, Batteries (Manganese Dry), Indoor FM Antenna, AM Loop Antenna.
--	--

* Specifications are subject to change without notice due to product improvements.



Manufactured under license from Dolby Laboratories. "Dolby", "Pro Logic" and the double-D symbol are trademarks of Dolby Laboratories.



"DTS" and "DTS Digital Surround" are registered trademarks of Digital Theater Systems, Inc.

• Set Menu Table

No.	MAIN MENU	SUB MENU: PRESET VALUE	SETTING RANGES
1.	SPEAKER SET	1A. CENTER SP: LARGE 1B. MAIN SP: LARGE 1C. REAR L/R SP: LARGE 1D. LFE/BASS OUT: BOTH 1E. MAIN LEVEL: NORMAL	LARGE, SMALL, NONE LARGE, SMALL LARGE, SMALL, NONE SW, MAIN, BOTH NORMAL, -10dB
2.	LFE LEVEL	SP LFE LEVEL: 0dB HP LFE LEVEL: 0dB	-20dB — 0dB (1dB step) -20dB — 0dB (1dB step)
3.	SP DELAY TIME	CENTER DELAY: 0ms	0ms — 5ms (1ms step)
4.	DYNAMIC RANGE	SP DYNAMIC RANGE: MAX HP DYNAMIC RANGE: MAX	MAX, STD, MIN MAX, STD, MIN
5.	L/R BALANCE	CENTER	L, ..., CENTER, ..., R (40 steps)
6.	HP TONE CONTROL	HP BASS: 0dB HP TREBLE: 0dB	-6dB — +3dB (1dB step) -6dB — +3dB (1dB step)
7.	I/O ASSIGNING	7C (1). OPTICAL IN 1: DVD 7C (2). COAXIAL IN 1: CD	DVD CD
8.	INPUT MODE	AUTO	AUTO/LAST
9.	DISPLAY SET	DIMMER: 0	-4 — 0 (1 step)
10.	MEMORY GUARD	OFF	OFF/ON

INTERNAL VIEW

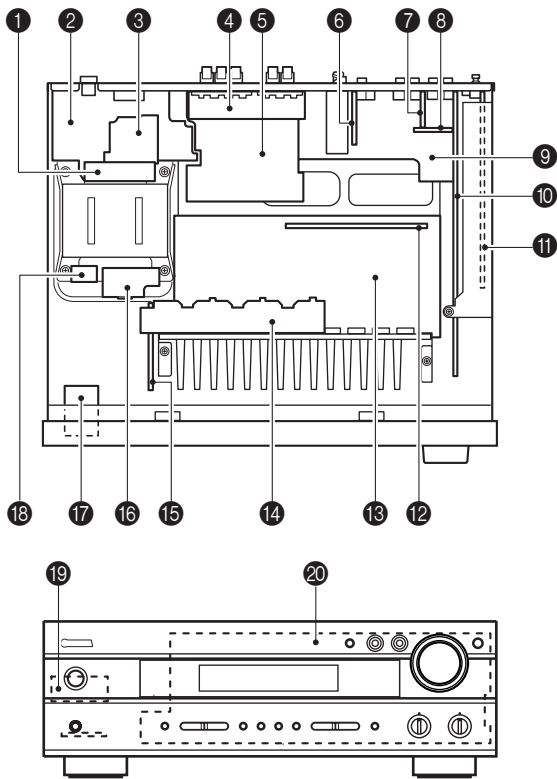

- ① FUNCTION (9) P.C.B.
- ② FUNCTION (7) P.C.B.
- ③ MAIN (6) P.C.B.
- ④ MAIN (10) P.C.B.
- ⑤ MAIN (2) P.C.B.
- ⑥ FUNCTION (3) P.C.B.
- ⑦ FUNCTION (2) P.C.B.
- ⑧ FUNCTION (10) P.C.B.
- ⑨ FUNCTION (4) P.C.B.
- ⑩ FUNCTION (1) P.C.B.
- ⑪ DSP P.C.B.
- ⑫ MAIN (3) P.C.B.
- ⑬ MAIN (1) P.C.B.
- ⑭ MAIN (4) P.C.B.
- ⑮ FUNCTION (5) P.C.B.
- ⑯ FUNCTION (6) P.C.B.
- ⑰ MAIN (5) P.C.B.
- ⑱ OPERATION (3) P.C.B.
- ⑲ OPERATION (2) P.C.B.
- ⑳ OPERATION (1) P.C.B.

DISASSEMBLY PROCEDURES

(Remove parts in the order as numbered.)
 Disconnect the power cable from the AC outlet.

1. Removal of Top Cover

- Remove 4 screws (1) and 4 screws (2). (Fig. 1)
- Slide the Top Cover rearward to remove it. (Fig. 1)

2. Removal of Front Panel Unit

- Remove 5 screws (3) and then remove the Front Panel Unit. (Fig. 1)
- Remove CB309~311. (Fig. 1)
- Loosen the harness fixture fixing the cable.

3. Removal of MAIN (5) P.C.B.

- Remove 1 screw (4) and then remove the Jack Stopper (5) upward. (Fig. 1)
- Remove the MAIN (5) P.C.B.. (Fig. 1)

4. Removal of DSP P.C.B.

- Remove 4 screws (6) and 1 screw (7), and then remove the Shield Case Cover. (Fig. 2)
- Remove 2 screws (8). (Fig. 2)
- Remove 2 screws (9). (Fig. 3)
- Remove CB308. (Fig. 2)
- Remove the Shield Case Cover and the DSP P.C.B.. (Fig. 2)

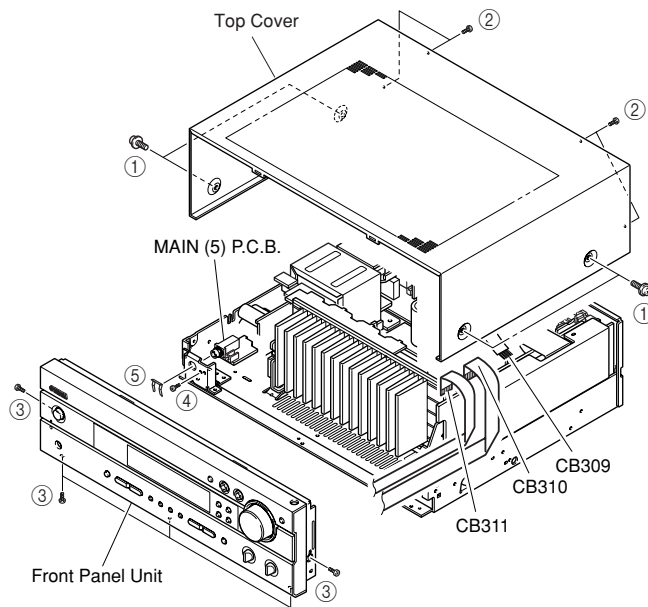

Fig. 1

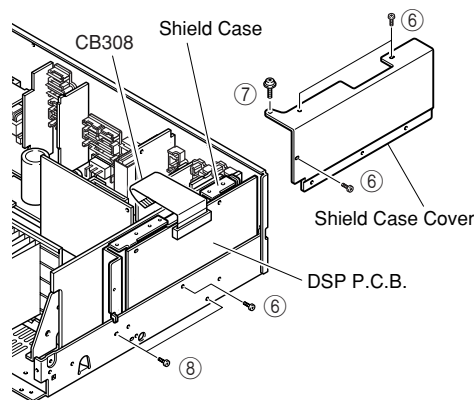

Fig. 2

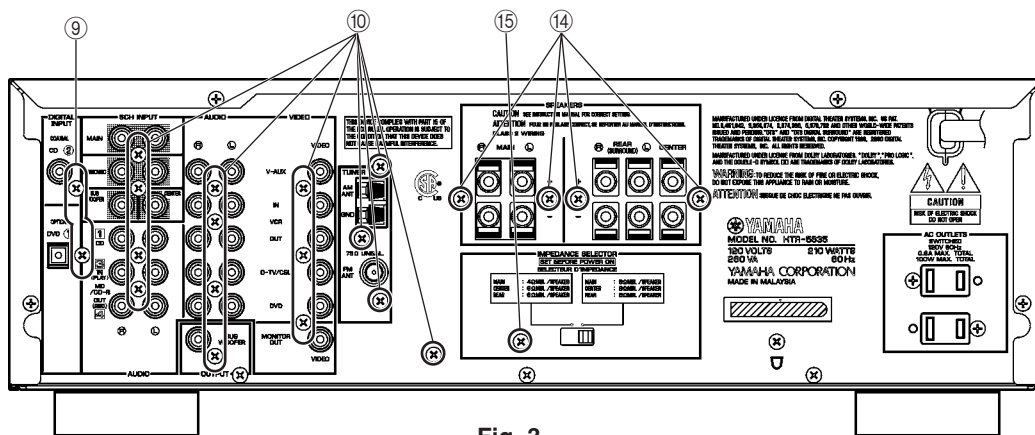

Fig. 3

5. Removal of FUNCTION (1) ~ (4), FUNCTION (10) P.C.B.s and Tuner

- a. Remove CB312. (Fig. 4)
- b. Remove 15 screws (10). (Fig. 3)
- c. Remove 1 screw (11). (Fig. 4)
- d. Remove FUNCTION (1) ~ (4), FUNCTION (10) P.C.B.s and the Tuner. (Fig. 4)

When checking the P.C.B.:

- Put the rubber sheet and a cloth over the equipment. Then place the P.C.B. upside down on the cloth and check it. (Fig. 5)
- Reconnect all cables (connectors) that have been disconnected.
- The P.C.B. removed from the rear panel does not work because its grounding is loose. Be sure to connect the ground of each P.C.B. to the chassis or GND with a jumper wire or the like.

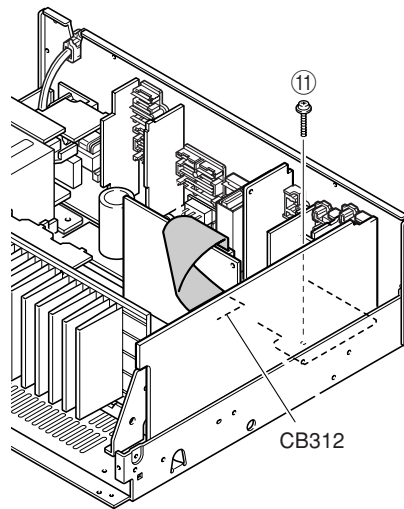
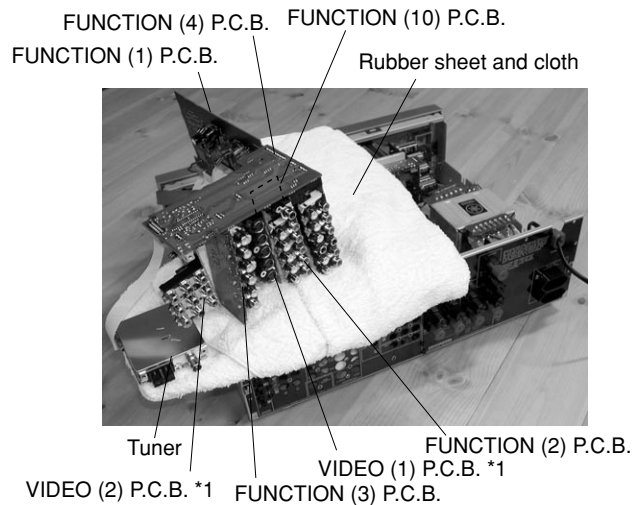

Fig. 4



*1: Not applied to HTR-5635

Fig. 5

6. Removal of MAIN (1), MAIN (3), MAIN (4) and FUNCTION (5) P.C.B.s

- a. Remove CB253. (Fig. 6)
- b. Remove 1 screw (12) and 2 screws (13). (Fig. 6)
- c. Remove MAIN (1), MAIN (3), MAIN (4) and FUNCTION (5) P.C.B.s. (Fig. 6)

7. Removal of MAIN (10) and MAIN (2) P.C.B.s

- a. Remove 4 screws (14). (Fig. 3)
- b. Remove MAIN (10) P.C.B.. (Fig. 6)
- c. Remove 1 screw (15). (Fig. 3)
- d. Remove 1 screw (16). (Fig. 6)
- e. Remove MAIN (2) P.C.B.. (Fig. 6)

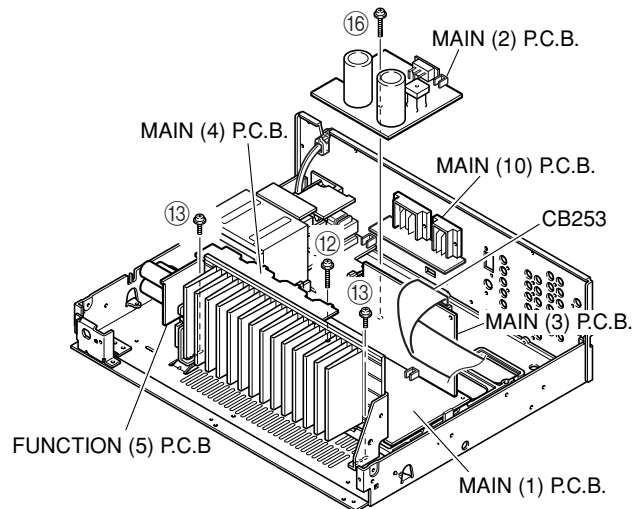

Fig. 6

Replacement of Power Transistor, Speaker Protective Relay

It is easy to replace the power transistor and speaker protective relay of this unit according to the following procedure.

- a. Remove the top cover. (Refer to "1. Removal of Top Cover" on p.7.)
- b. Remove 1 screw (⑫) and 2 screws (⑬). (Fig. 6)
- c. Raise the MAIN (1) P.C.B. (Fig. 7)
- d. In this state, the power transistor and speaker protective relay can be replaced. To check the operation in this state, it is necessary to connect the grounding cable.

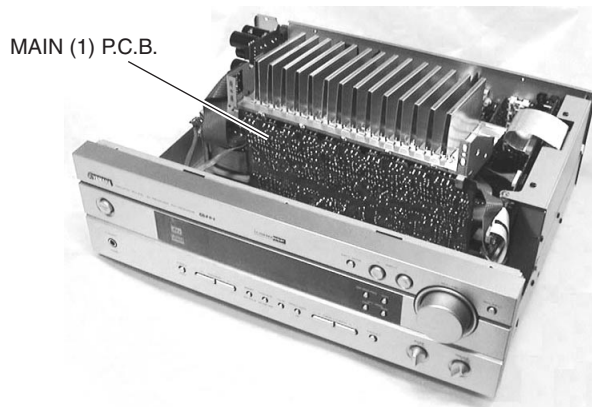

Fig. 7

■ SELF DIAGNOSIS FUNCTION (DIAG)

There are 14 DIAG menu items, each of which has sub-menu items.

Listed in the table below are menu items and sub-menu items.

Note that not all menu items listed will apply to the models covered in this service manual.

No	DIAG menu	sub-menu
1	DSP THROUGH 1. ANALOG BYPASS	1. ANALOG BYPASS 2. YSS 0dB 3. YSS Front 0dB 4. YSS FULL BIT 5. YSS FULL BIT F
2	RAM THROUGH 2. RAM 0dB	RAM 0dB
3	PRO LOGIC 3. PRO LOGIC I	1. PRO LOGIC I 2. PRO LOGIC II
4	SPEAKER SET 4. MAIN: SML 0dB	1. MAIN: SMALL 0dB 2. CENTER: NONE 3. LFE/BASS: MAIN 4. Front Mix: 5ch 5. REAR CENTER (Not applied to HTR-5635)
5	MARGIN CHECK 5. MAIN 12dB	1. MAIN 12 dB MARGIN 2. MAIN 18 dB MARGIN
6	OTHER INPUT 6. EXTERNAL DEC	EXTERNAL DECODER
7	DISPLAY CHECK 7. VFD CHECK	1. VFD CHECK (Initial display) 2. VFD DISP OFF (All segments OFF) 3. VFD DISP ALL (All segments ON 100%) 4. VFD DIMMER (All segments ON 50%) 5. CHECKED PATTERN (ON in lattice)
8	MANUAL TEST 8. TEST ALL	1. TEST ALL 2. TEST MAIN L 3. TEST CENTER 4. TEST MAIN R 5. TEST REAR R 6. TEST REAR CENTER (Not applied to HTR-5635) 7. TEST REAR L 8. TEST LFE
9	FACTORY PRESET 9. PRESET INHI	1. PRESET INHIBITED (memory initialization inhibited) 2. PRESET RESERVED (memory initialized)
10	AD DATA CHECK /FAN TEST PS:038	1. PS (protection) 2. K0/K1 (panel key) 3. K2 (panel key) 4. IMP SW/POWER LIMIT 5. THM/FAN OUT 6. FAN DRIVE TEST: HIGH (Not applied to HTR-5635) 7. FAN DRIVE TEST: MID (Not applied to HTR-5635) 8. FAN DRIVE TEST: LOW (Not applied to HTR-5635)
11	IF STATUS IS1:440308C000	1. INSIDE STATUS 1 (5 Byte) 2. INSIDE STATUS 2 (3 Byte) 3. INSIDE STATUS 3 (4 Byte) 4. CHANNEL STATUS 1 (5 Byte) 5. CHANNEL STATUS 2 (5 Byte) 6. CHANNEL STATUS 3 (5 Byte) 7. CHANNEL STATUS 4 (5 Byte) 8. CHANNEL STATUS 5 (4 Byte) 9. BSI (YSS) 1 (5 Byte) 10. BSI (YSS) 2 (5 Byte)

No	DIAG menu	sub-menu
		11. BSI (YSS) 3 (5 Byte)
		12. BSI (YSS) 4 (4 Byte)
		13. BSI (CS) 1 (5 Byte)
		14. BSI (CS) 2 (5 Byte)
		15. BSI (CS) 3 (5 Byte)
		16. BSI (CS) 4 (5 Byte)
		17. BSI (CS) 5 (1 Byte)
		18. YSS938-1 (5 Byte)
		19. YSS938-2 (5 Byte)
		20. YSS938-3 (4 Byte)
		21. CS49329 (3 Byte)
		22. Mute Trigger (5 Byte)
12	DSP RAM CHECK <input type="text" value="YSS BUS: NoEr"/>	1. YSS938 BUS CHECK 2. PLD/CS BUS CHECK
13	SOFT SWITCH <input type="text" value="13. SW :PCB"/>	1. SW MODE 2. MODEL SETTING 3. TUNER DESTINATION 4. TUNER EXIST 6. RDS EXIST 7. VIDEO FORMAT (Not applied to HTR-5635)
14	ROM VERSION/CHECK SUM/ PORT <input type="text" value="VER. XXXXX"/>	1. VERSION 2. CHECK SUM ALL/PROGRAM 3. PORT 4. AAC PORT

• Starting DIAG

Press the “STANDBY/ON” key while simultaneously pressing those two keys of the main unit as indicated in the figure below.

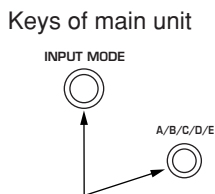

Turn on the power while pressing these keys.

• Starting DIAG in the protection cancel mode

If the protection function works and causes hindrance to trouble diagnosis, cancel the protection function as described below, and it will be possible to enter the DIAG mode. (The protection functions other than the excess current detect function will be disabled.)

Press the “STANDBY/ON” key while simultaneously pressing those two keys indicated in the figure above. At this time, keep pressing those two keys for 3 seconds or longer.

In this mode, the “SLEEP” segment of the FL display of the main unit flashes to indicate that the mode is DIAG mode with the protection functions disabled.

CAUTION!

Using this product with the protection function disabled may cause damage to itself. Use special care for this point when using this mode.

• Canceling DIAG

[1] Before canceling DIAG, execute setting for PRESET of DIAG menu No.9 (Memory initialization inhibited or Memory initialized).

* In order to keep the user memory stored, be sure to select PRESET INHIBITED (Memory initialization inhibited).

[2] Turn off the power by pressing the “STANDBY/ON” key of the main unit.

• Display provided when DIAG started

The FL display of the main unit displays the protection function history data and the version (1 alphabet) and the DIAG menu (sub-menu (ANALOG BYPASS) of DIAG menu No.1 DSP THROUGH) a few seconds later.

When there is no history of protection function:

Opening message

DIAG menu display

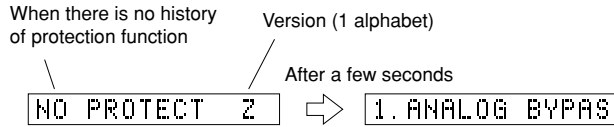

When there is a history of protection function:

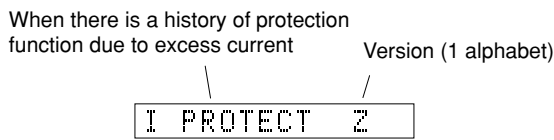

Cause: An excessive current flowed through the power amplifier.

Supplementary information: As current of the power transistor is detected, the abnormal channel can be identified by checking the current detect transistor.

Turning on the power without correcting the abnormality will cause the protection function to work immediately and the power supply will instantly be shut off.

Note)

- Applying the power to a unit without correcting the abnormality can be dangerous and cause additional circuit damage.
- The output transistors in each amplifier channel should be checked for damage before applying any power.
- Amplifier current should be monitored by measuring across the emitter resistors for each channel.

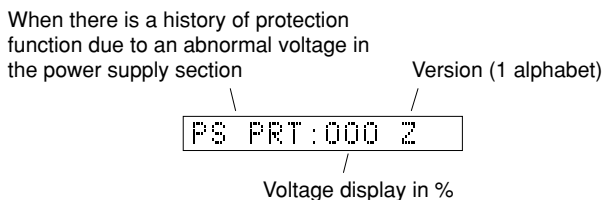

Cause: The voltage in the power supply section is abnormal.

Supplementary information: The abnormal voltage is displayed in % based on 5V as 100%.

Turning on the power without correcting the abnormality will cause the protection function to work 1 second later and the power supply will be shut off.

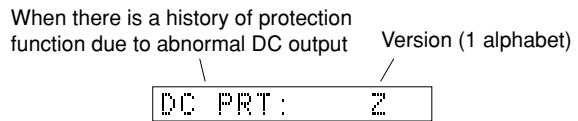

Cause: DC output of the power amplifier is abnormal.

Turning on the power without correcting the abnormality will cause the protection function to work 3 seconds later and the power supply will be shut off.

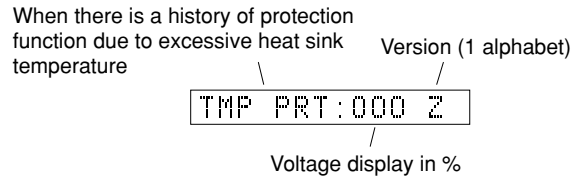

Cause: The temperature of the heat sink is excessive.

Supplementary information: The abnormal voltage is displayed in % based on 5V as 500%.

Turning on the power without correcting the abnormality will cause the protection function to work 1 second later and the power supply will be shut off.

- * Additional causes of protection can be due to loose connections, associated components, CPU, etc.
- * For the protection voltage value, refer to DIAG menu No.10 described later.

• History of protection function

When the protection function has worked, its history is stored in memory with a backup. Even if no abnormality is noted while servicing the unit, an abnormality which has occurred previously can be defined as long as the backup data has been stored.

The history of the protection function is cleared when DIAG is cancelled by selecting PRESET RESERVED (Memory initialized) of DIAG menu No.9 or when the backup data is erased.

• Display during menu operation

During the DIAG operation, the function at work is indicated on the FL indicator. The contents displayed during the function operation are described in the later section on details of functions

• Operation procedure of DIAG menu and SUB-MENU

There are 14 MENU items, each of which has some SUB-MENU items.

DIAG menu selection

Main unit: Select the menu using ▷ (Forward) and ◁ (Reverse) keys of PRESET/TUNING.

Remote control unit: Select the menu using ∨ (Forward) and ∧ (Reverse) keys.

SUB-MENU selection

Main unit: Select the sub-menu using ▷ (Forward) and ◁ (Reverse) keys of PROGRAM.

Remote control unit: Select the sub-menu using > (Forward) and < (Reverse) keys.

Keys of main unit

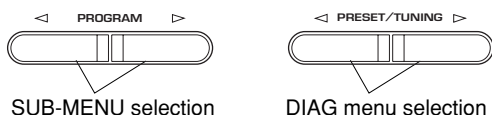

Keys of remote control

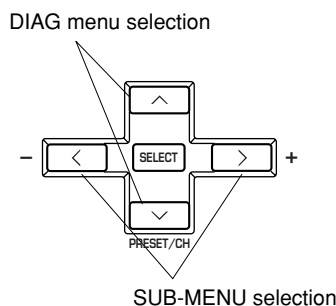

• Functions in DIAG mode

In addition to the DIAG menu items, functions as listed below are available.

- Input selection, 6CH input
- Center/Rear/Sub-woofer level adjustment
- Muting
- Power on/off
- Master volume
- * Functions related to the tuner and the set menu are not available.
- * It is possible to confirm Menu No.11 IF STATUS while keeping the signal process (operation status) of each DIAG menu by using the input mode key of the main unit.

• Initial settings used to start DIAG

The following initial settings are used when starting DIAG. When DIAG is canceled, these settings are restored to those before starting DIAG.

- Master volume: -40dB
- Input: DVD (6CH INPUT OFF)
- Effect level: 0dB
- Audio mute: OFF
- Speaker setting: LARGE / BASS OUT = BOTH
- DIAG menu: DSP THROUGH (1. ANALOG BYPASS)

• Details of DIAG menu

With full-bit output specified in some modes, it is possible to execute 0dBFS output without head margin in each channel.

1. DSP THROUGH

Main DSP of YSS938 is selected for MAIN L/R output.

ANALOG BYPASS

- The signal for L/R is output as it is without passing through the DSP section.

1. ANALOG BYPASS

Reference data

INPUT: DVD ANALOG

SWFR: 50Hz, Others: 1kHz

Input level	Volume	SPEAKER OUTPUT (1kHz)			SUBWOOFER OUTPUT (50Hz)
		MAIN L/R	CENTER	RL/RR	
Both ch, -20 dBm	-10 dB	+14.3 dBm	- ∞	- ∞	- ∞

YSS 0dB

- The signal is output including the head margin.
Head margin:
Main L/R: 0dBFS, Center: 0dBFS,
RL/RR: -12dBFS, SWFR: Add L/R signal at -20dBFS.

1. YSS 0dB

Reference data

INPUT: DVD ANALOG

SWFR: 50Hz, Others: 1kHz

Input level	Volume	SPEAKER OUTPUT (1kHz)			SUBWOOFER OUTPUT (50Hz)
		MAIN L/R	CENTER	RL/RR	
Both ch, -20 dBm	-10 dB	+14.0 dBm	+14.0 dBm	+14.0 dBm	-2.5 dBm

YSS Front 0dB

- The front CH signal including the head margin is output at the main CH.
Head margin:
Main L/R: 0dBFS, Center: -6dBFS,
RL/RR: -12dBFS, SWFR: Add L/R signal at -20dBFS.

1. YSS Front0dB

Reference data

INPUT: DVD ANALOG

SWFR: 50Hz, Others: 1kHz

Input level	Volume	SPEAKER OUTPUT (1kHz)			SUBWOOFER OUTPUT (50Hz)
		MAIN L/R	CENTER	RL/RR	
Both ch, -20 dBm	-10 dB	+25.0 dBm	- ∞	- ∞	- ∞

YSS FULL BIT

- The signal is output in digital full bit without including the head margin.

1. YSS FULL BIT

Reference data

INPUT: DVD ANALOG

SWFR: 50Hz, Others: 1kHz

Input level	Volume	SPEAKER OUTPUT (1kHz)			SUBWOOFER OUTPUT (50Hz)
		MAIN L/R	CENTER	RL/RR	
Both ch, -20 dBm	-10 dB	+14.6 dBm	+14.4 dBm	+14.5 dBm	-2.5 dBm

YSS FULL BIT F

- The front CH signal is output in digital full bit at the main CH.

1. FULL BIT F

Reference data

INPUT: DVD ANALOG

SWFR: 50Hz, Others: 1kHz

Input level	Volume	SPEAKER OUTPUT (1kHz)			SUBWOOFER OUTPUT (50Hz)
		MAIN L/R	CENTER	RL/RR	
Both ch, -20 dBm	-10 dB	+14.0 dBm	- ∞	- ∞	- ∞

DSP THROUGH ~
YSS (Analog/PCM)

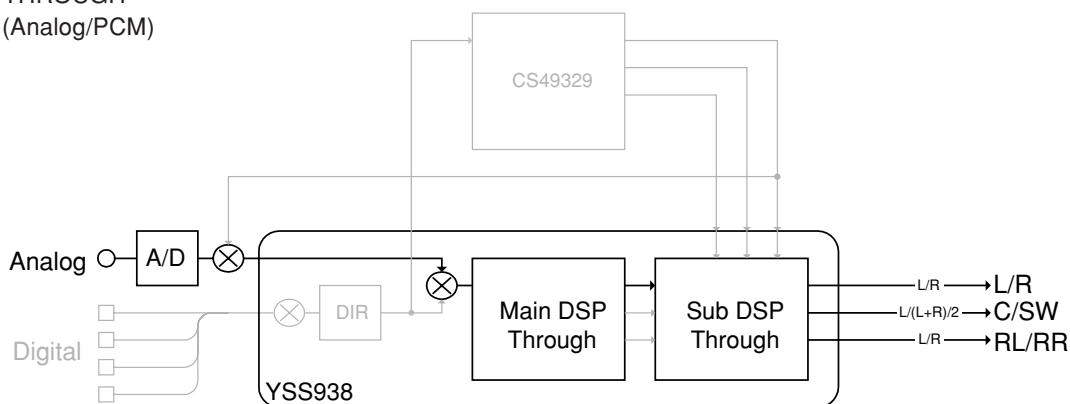

2. RAM THROUGH

This function is for YSS938 only.

Only the CT signal is output through the Sub DSP - DRAM.

RAM 0dB

2. RAM 0dB

Reference data

INPUT: DVD ANALOG

SWFR: 50Hz, Others: 1kHz

Input level	Volume	SPEAKER OUTPUT (1kHz)			SUBWOOFER OUTPUT (50Hz)
		MAIN L/R	CENTER	RL/RR	
Both ch, -20 dBm	-10 dB	- ∞	+14.0 dBm	- ∞	- ∞

RAM THROUGH ~
(Auto)

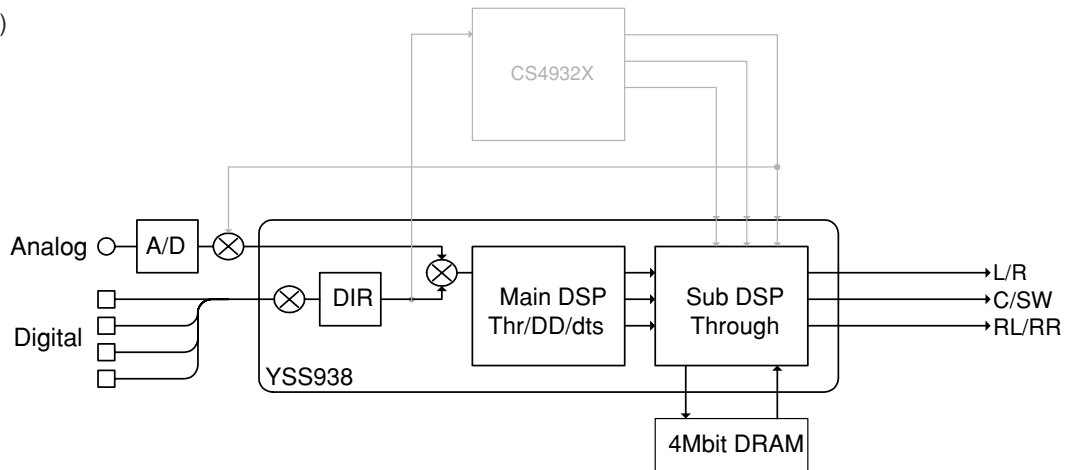

3. PRO LOGIC

The L/C/R/RL/RR signals undergo the Pro-Logic processing and C/RL/RR signals are output through Sub DSP-DRAM. Main DSP is selected for MAIN L/R output. Using the sub-menu, it is possible to select PRO LOGIC I, II (Movie). The Auto Input Balance function is always off. The LFE signal is not output when decoding in the PRO LOGIC I, II mode.

PRO LOGIC I

3. PRO LOGIC I

Reference data

INPUT: DVD ANALOG

SWFR: 50Hz, Others: 1kHz

Input level	Volume	SPEAKER OUTPUT (1kHz)			SUBWOOFER OUTPUT (50Hz)
		MAIN L/R	CENTER	RL/RR	
Each ch, -20 dBm	-10 dB	+14.2 dBm	- ∞	- ∞	- ∞
Both ch, -20 dBm	-10 dB	- ∞	+17.0 dBm	- ∞	- ∞

PRO LOGIC II

3. PRO LOGIC II

Reference data

INPUT: DVD ANALOG

SWFR: 50Hz, Others: 1kHz

Input level	Volume	SPEAKER OUTPUT (1kHz)			SUBWOOFER OUTPUT (50Hz)
		MAIN L/R	CENTER	RL/RR	
Each ch, -20 dBm	-10 dB	+14.2 dBm	- ∞	- ∞	- ∞
Both ch, -20 dBm	-10 dB	- ∞	+17.0 dBm	- ∞	- ∞

Dolby Pro Logic (Auto)

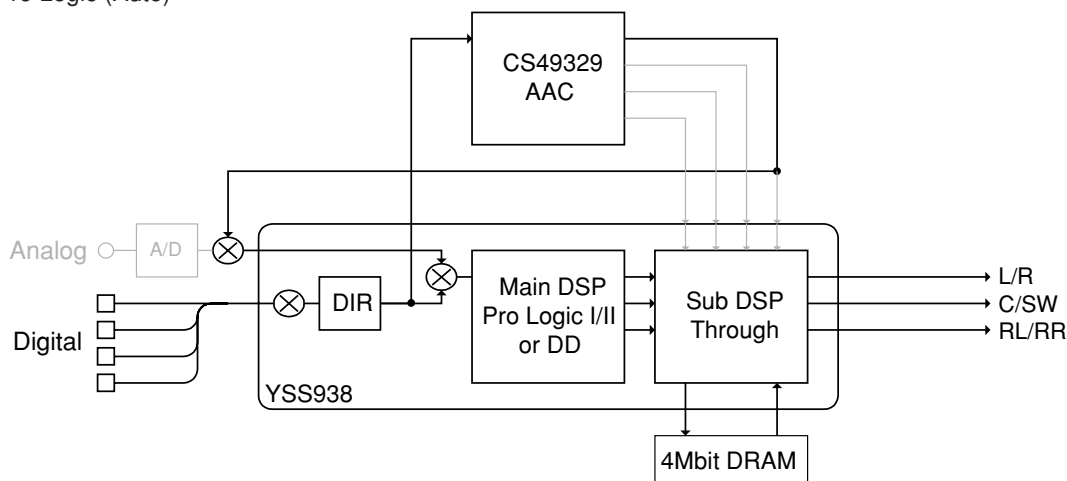

4. SPEAKERS SET

The input signal is automatically identified and switched in the priority order of dts → DOLBY DIGITAL → AAC → PCM AUDIO → Analog (A/D) according to the signal detection.

The signals output from the DSP block are the same as 1.
 DSP THROUGH: YSS 0dB.

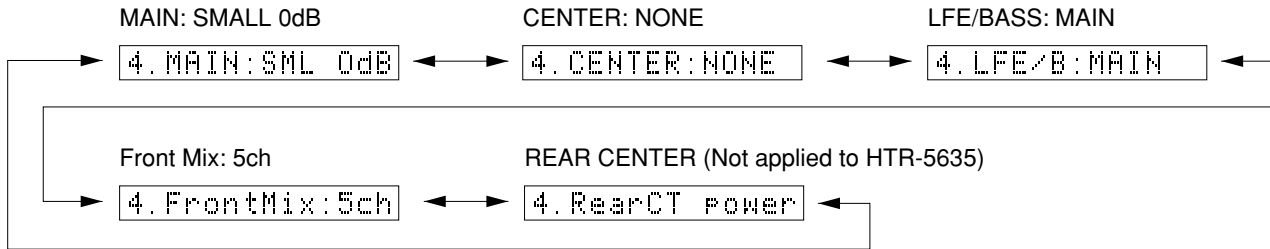

The analog switch settings for each sub-menu are as shown in the table below.

Sub-menu		CENTER SP	REAR SP	MAIN SP	MAIN LEVEL	LFE/BASS
1	MAIN: SMALL 0dB	LARGE	LARGE	SMALL	0dB	SWFR
2	CENTER: NONE	NONE	LARGE	LARGE	0dB	BOTH
3	LFE/BASS: MAIN	SMALL	SMALL	LARGE	0dB	MAIN
4	FRONT MIX: 5CH	LARGE	LARGE	LARGE	0dB	BOTH
5	REAR CENTER: POWER	LARGE	LARGE	LARGE	0dB	BOTH

- LARGE:** This mode is used with a speaker with high bass reproduction performance (a large unit). Full bandwidth signals are output.
- SMALL:** This mode is used with a speaker with low bass reproduction performance (a small unit). The signals of 90Hz or less are mixed into the channel specified by LFE/BASS.
- NONE:** This mode is used with no center speaker. The center content is reduced by 3dB and distributed to MAIN L/R.

Reference data

INPUT: DVD ANALOG (Both ch)

Sub-menu	Input level	Volume	SPEAKER OUTPUT (1kHz)			SUBWOOFER OUTPUT (50Hz)	
			MAIN L/R	CENTER	RL/RR		
1	MAIN: SMALL 0dB	1kHz/90Hz Both ch, -20 dBm	-10 dB	+14.8/+11.5 dBm	- ∞	- ∞	- ∞
2	CENTER: NONE	1kHz Both ch, -20 dBm	-10 dB	+11.9 dBm	+14.1 dBm	- ∞	- ∞
3	LFE/BASS: MAIN	50Hz Both ch, -20 dBm	-10 dB	+13.0 dBm	- ∞	- ∞	- ∞
4	FRONT MIX: 5CH	1kHz Both ch, -20 dBm	-10 dB	+24.0 dBm	- ∞	- ∞	- ∞

5. MARGIN CHECK

The signal is output including the head margin.

MAIN 12dB MARGIN

5. MAIN 12dB

Reference data

INPUT: DVD ANALOG

SWFR: 50Hz, Others: 1kHz

Input level	Volume	SPEAKER OUTPUT (1kHz)			SUBWOOFER OUTPUT (50Hz)
		MAIN L/R	CENTER	RL/RR	
Both ch, -20 dBm	-10 dB	+14.0 dBm	- ∞	- ∞	- ∞

MAIN 18dB MARGIN

5. MAIN 18dB

Reference data

INPUT: DVD ANALOG

SWFR: 50Hz, Others: 1kHz

Input level	Volume	SPEAKER OUTPUT (1kHz)			SUBWOOFER OUTPUT (50Hz)
		MAIN L/R	CENTER	RL/RR	
Both ch, -20 dBm	-10 dB	+14.0 dBm	- ∞	- ∞	- ∞

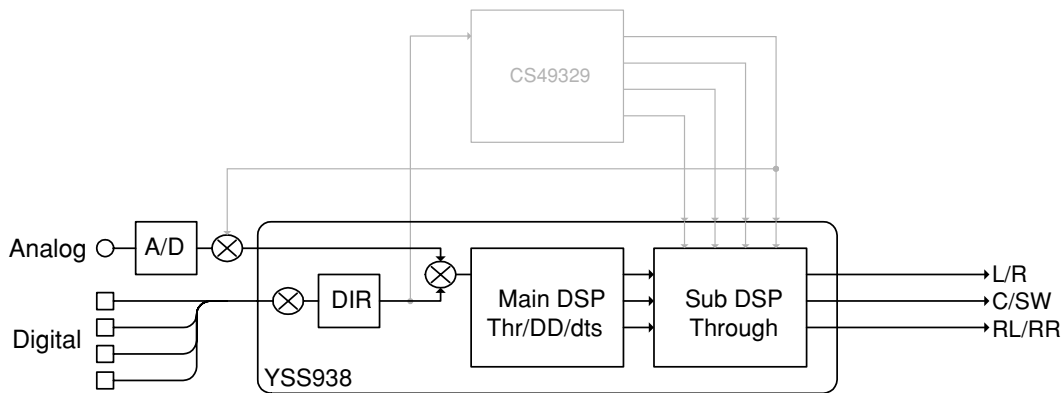

6. OTHER INPUT

The signal input through the 6CH INPUT terminals is output.

EXTERNAL DECODER

6. EXTERNAL DEC

Reference data

INPUT: 6CH INPUT

SWFR: 50Hz, Others: 1kHz

Input level	Volume	SPEAKER OUTPUT (1kHz)			SUBWOOFER OUTPUT (50Hz)
		MAIN L/R	CENTER	RL/RR	
Both ch, -20 dBm	-10 dB	+14.3 dBm	+14.3 dBm	+14.3 dBm	-7.5 dBm

7. DISPLAY CHECK

This program is used to check the FL display section. The display condition varies as shown below according to the sub-menu operation. The signals are processed using EFFECT OFF (The L/R signal is output using ANALOG MAIN BYPASS.)

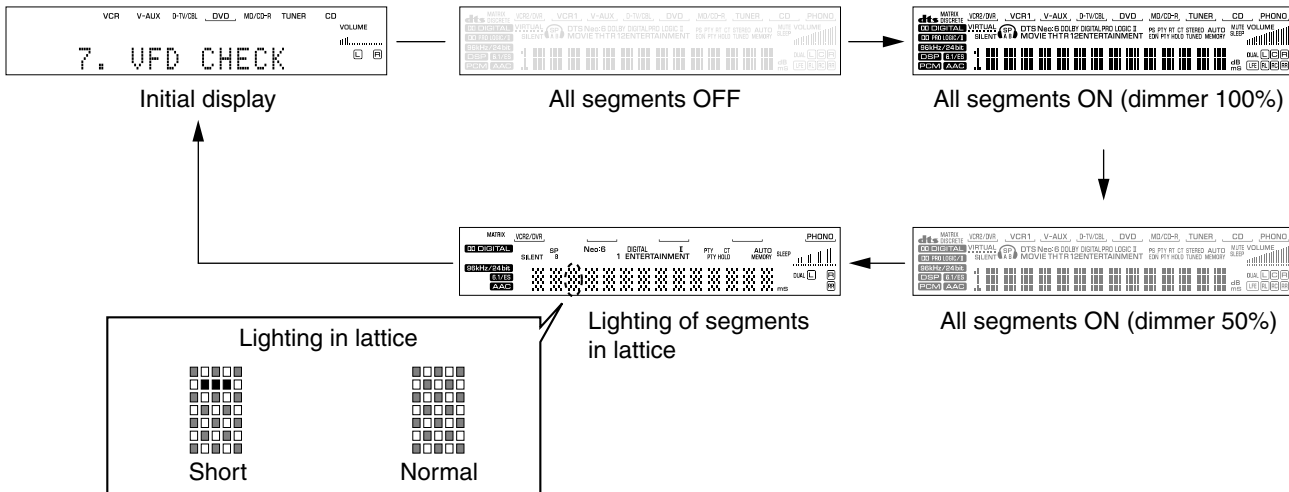

Segment conditions of the FL driver and the FL tube are checked by turning ON and OFF all segments. Next, the operation of the FL driver is checked by using the dimmer control. Then a short between segments next to each other is checked by turning ON and OFF all segments alternately (in lattice). (In the above example, the segments in the second row from the top are shorted.)

8. MANUAL TEST

The noise generator built into the DSP outputs the test noise through the channels specified by the sub-menu. The noise frequency for LFE is 35 to 250 Hz. Other than that, the center frequency is 800Hz.

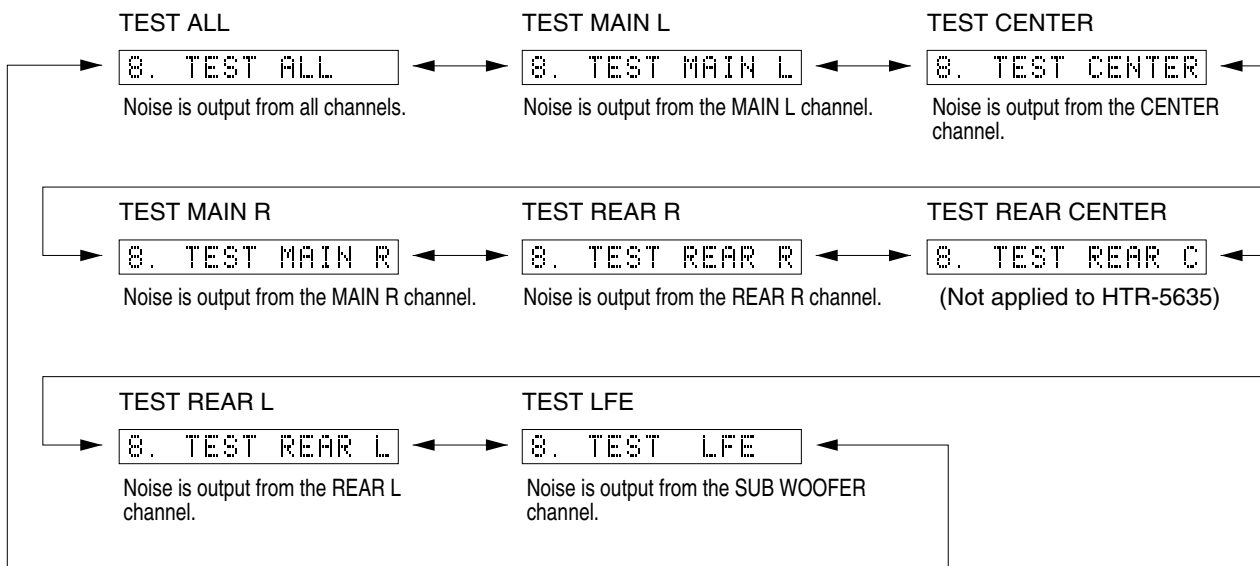

9. FACTORY PRESET

This menu is used to reserve and inhibit initialization of the back-up RAM. The signals are processed using EFFECT OFF. (The L/R signal is output using ANALOG MAIN BYPASS.)

9. PRESET INHI

PRESET INHIBIT (Initialization inhibited)
RAM initialization is not executed. Select this sub-menu to protect the values set by the user.



9. PRESET RSRV

PRESET RESERVED (Initialization reserved)
Initialization of the back-up RAM is reserved. (Actually, initialization is executed the next time that the power is turned on.) Select this sub-menu to reset to the original factory settings or to reset the RAM.

CAUTION: Before setting to the PRESET RESERVED, write down the existing preset memory content of the Tuner in a table as shown below. (This is because setting to the PRESET RESERVED will cause the user memory content to be erased.)

Preset group	P1	P2	P3	P4	P5	P6	P7	P8
A								
B								
C								
D								
E								

• PRESET STATIONS

STATION		
PAGE	NO.	FM FACTORY PRESET DATA (MHz)
A/C/E	1	87.5
	2	90.1
	3	95.1
	4	98.1
	5	107.9
	6	88.1
	7	106.1
	8	107.9

STATION		
PAGE	NO.	AM FACTORY PRESET DATA (kHz)
B/D	1	630
	2	1080
	3	1440
	4	530
	5	1710
	6	900
	7	1350
	8	1400

10. AD DATA CHECK/FAN TEST

This menu is used to display the A/D conversion value of the terminals which detects panel keys of the main unit and protection functions in % using the sub-menu. During signal processing, the condition before execution is maintained.

When K0/K1 or K2 menu is selected, keys become non-operable due to detection of the values of all keys. However, it is possible to advance to the next sub-menu by turning the VOLUME of the main unit. When using this function, note that turning the VOLUME more than 2 click would cause the volume value to change.

* The figures in the diagram are given as reference only.

PS (protection detection)

Power supply voltage protection value (Normal value: 28 to 47)

* If PS is out of the normal value range, the protection function works to turn off the power.

PS:038

K0/K1 (Panel key of main unit)

K2 (Panel key of main unit)

A/D of the key fails to function properly when the standard value is deviated. In this case, check the constant of partial pressure resistor, solder condition, etc. Refer to table 1.

K0:100 K1:100

K2:100

[Table 1]

Display	K0	K1	K2
0	STEREO EFFECT	PRESET/TUNING EDIT	INPUT MODE
9	◁ PROGRAM	FM/AM	◁ INPUT
20	PROGRAM ▷	MEMORY	INPUT ▷
37	◁ PRESET/TUNING	MAN'L/AUTO FM TUNING MODE	6CH INPUT
61	PRESET/TUNING ▷	AUTO/MAN'L MONO	-
79	A/B/C/D/E	-	-
90	-	-	-
97	-	-	-

IMP SW/POWER LIMIT (Impedance/power limiter detection)

IMP: 8 or 4 ohm impedance switch setting

PL: Power limiter detection value

The voltage value of pin No. 95 of IC301 is displayed, using 5V/256 as standard.

When the power is turned on, the impedance of the speaker being connected is automatically detected, using the input voltage value of pin No. 95 of IC301.

Input voltage value	0 - 460mV	461mV - 5V
Impedance of speaker	4 ohms	8 ohms

The port output is controlled by using the input voltage value of pin No. 95 of IC301.

When higher than VthH, the port output is changed from L to H.

When lower than VthL, the port output is changed from H to L.

Impedance	PORT	VthL	VthH
8/6 ohms	No.10	2.85V	3.30V
4 ohms	No.11	1.88V	2.38V

IMP:8 PL:009

THM/FAN OUT (temperature detection/fan drive level)

THM: 500% display of the voltage based on the temperature detected value. Reference voltage : 5V (Normal value: U, C models 30 to 173)

Fan: Current fan drive level on the left and the past fan drive history on the right.

(Not applied to HTR-5635)

THM:086Fan:.....

11. IF STATUS (Input function status)

Using the sub-menu, the status data is displayed one after another in the hexadecimal notation.

During signal processing, the status before execution of this menu is maintained.

* Numeric values in the figure example are for reference.

IS1-3 (Internal status):

Indicates the status information of the microprocessor.

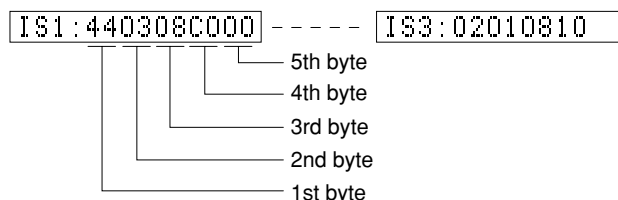

<1st byte> Digital input/output setting value

Upper 4 bits: REC OUT selected /

lower 4 bits: INPUT selected

Value	Choice	Preset name
0	NONE	
1	OPTA	
2	OPTB	
3	OPTC	DVD
4	OPTD	
8	COAXA	CD

<2nd byte> Fs information of reproduction signal

Display	00	01	02	03	04	05	06	0A	0B	0C	0D
Fs (kHz)	Analog	32	44.1	48	64	88.2	96	Unknown NRM	Unknown DBL	Unknown QUAD	Not defined

<3rd byte> Audio code mode information of reproduction signal

Display	00	01	02	03	04	05	06	07	08	09	0A	0B	0C	0D
Audio Code	MULTI MONO	1+1	1/0	2/0	3/0	2/1	3/1	2/2	3/2	2/3	3/3	OVER 6.1	MULTI PCE	Unknown

<4th byte> Format information of reproduction signal

*1: Analog processing used for digital reproduction is not possible because of a commercial bit or 4-ch audio reason.

Display	Signal format
00	Analog (Unlock)
01	Incorrect digital (*1)
10	PCM Audio
20	Digital Data
21	IEC1937 Data
22	None PCM
23	Unknown
50	dts
51	Red dts
54	dts-ES MATRIX
58	dts-ES DISCRETE
5C	dts-ES (Both flag)
60	AAC
C0	Dolby Digital
C1	D.D. Karaoke
C4	D.D.6.1 (D.D.EX)

<5th byte> Signal processing status information

*2: With digital signals other than 32kHz, 44.1kHz and 48kHz, through processing method is used for reproducible signals.

bit7	MUTE request	bit3	–
bit6	Red dts flashing	bit2	Through & bypass (*2)
bit5	6.1/ES processing	bit1	–
bit4	FULL MUTE (ON: 1)	bit0	dts analog mute

CS1-5: Indicates channel status information of the input signal (IEC60958).

CS1:0299000200 ----- CS5:00000000

BY1-4: Indicates information of the bit stream included in the DOLBY DIGITAL signal.

BY1:1E40E1301B ----- BY4:01FFFFFF

BC1-5: Indicates information of the bit stream included in the dts signal.

BC1:000070FFFF ----- BC5:C4

YS1-3: Indicates device status information of YSS938 (IC600).

* The numeric value in the figure is an example for reference.

YS1:FED2004F97

Byte No.	Function
1	YSS MUTE Reg
2	YSS MODE Reg
3	YSS IPORT BIT 7-0
4	YSS IPORT BIT 14-8
5	YSS OPORT

YS2:0101418000

Byte No.	Function
1	IEC 1937 Preamble Pc
2	Data Stream Reg
3	Status Reg
4	YSS ZERO Reg
5	MIREG

YS3:1A41803D

Byte No.	Function
1	DIR Status
2	DIR fs
3	DIR fs count
4	YSS ZEROBF

CS: CS49329 Unsolicited Messages (AUTODETECT_RESPONSE)

CS :000001

MTT: Mute Trigger

MTT:0020000007

Byte No.	Function
1	Mute condition
2	Factor of the last mute
3	Error count of YSS938-FSCNT
4	Mute count by YSS938-FSCNT
5	Error factor of down load of CS49329

12. DSP RAM CHECK

This menu is used to self-diagnose whether or not the bus connection for the YSS938 and the external RAM is made properly.

During signal processing, the status before execution of this menu is maintained.

The address bus and the data bus are checked and the connection condition is displayed.

When no error is detected, "NoEr" appears on display.

YSS938 Bus Check

YSS BUS:NoEr

Display	Description
WAIT	Bus is being checked.
NoEr	No error detected.
DATA	Data bus shorted or open.
RSCS	/RAS or /CAS shorted, or open.
ADDR	Address bus shorted or open.

PLD/SRAM BUS CHECK

CS BUS:NoEr

Display	Description
WAIT	Bus is being checked.
NoEr	No error detected.
DATA	Data bus shorted or open. (XX: 00-07)
ADDR	Address bus shorted or open. (XX: 00-0E)

13. SOFT SW

This menu is used to switch the function settings on P.C.B. through the software so as to activate the product.

The protection function follows the P.C.B. settings. When connected to AC or in the maker preset state, the unit is initialized to the P.C. B. setting. Display of each function after initialization varies depending on settings on P.C.B. The operation mode can be changed by selecting the sub-menu and then using the EFFECT key. With SOF selected for the SW mode, the settings become effective.

SW MODE: PCB or SOFT can be selected.

13. SW :PCB

MODEL SETTING: V430, V530, AX630, V630, V730 or DVX can be selected.

13. MODEL:V430

TUNER DESTINATION: J, UC, ALG or R can be selected.

13. DEST :UC

TUNER: NOT or EXIST can be selected.

13. TUNER:EXIST

RDS: NOT or EXIST can be selected.

13. RDS :NOT

VIDEO FORMAT: NTSC or PAL can be selected.
(Not applied to HTR-5635)

13. VIDEO:NTSC

14. MICROPROCESSOR INFORMATION

The version, checksum and the port specified by the microprocessor are displayed. The signal is processed using EFFECT OFF. The checksum is obtained by adding the data at every 8 bits for each program area and expressing the result as a 4-figure hexadecimal data.

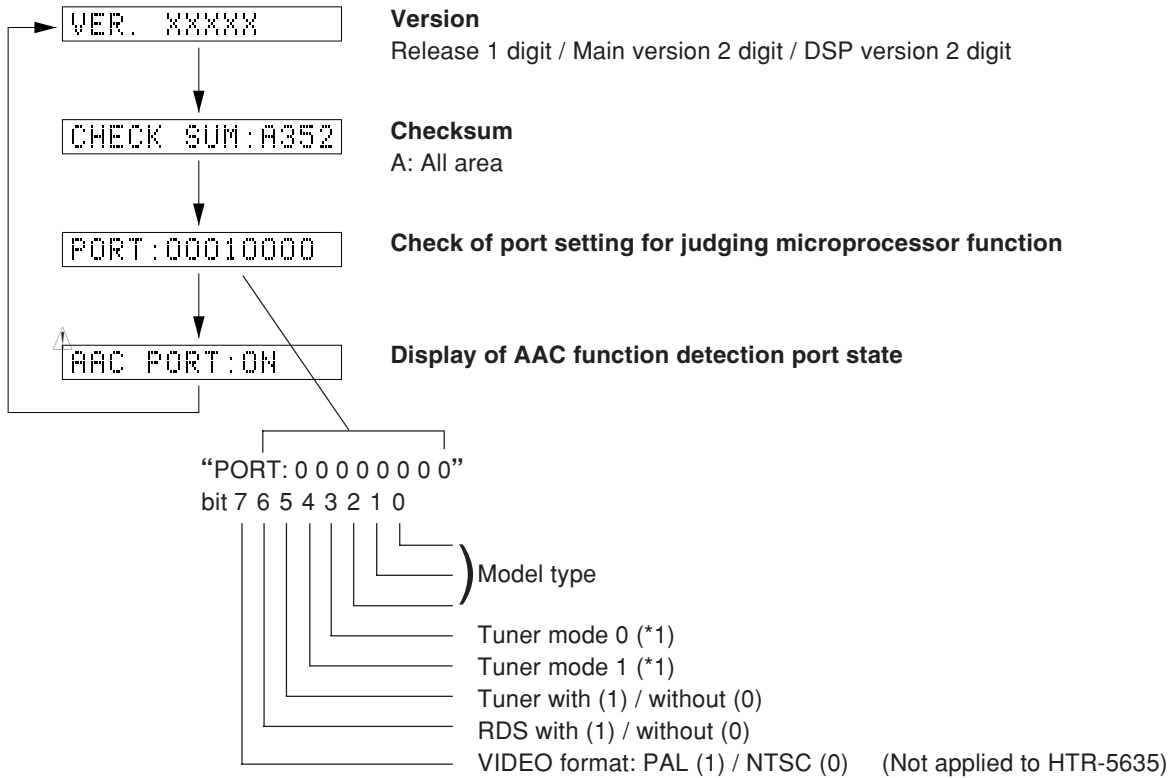

*1 (Tuner mode)

Tuner mode 1	Tuner mode 0	Tuner frequency
0	0	AM: 531-1611kHz/9kHz FM: 76.0-90.0MHz/100kHz
1	0	AM: 531-1611kHz/9kHz FM: 87.5-108.0MHz/50kHz
0	1	AM: 530-1710kHz/10kHz FM: 87.5-107.9MHz/200kHz
1	1	R destination, Port6: LOW AM: 530-1710kHz/10kHz FM: 87.5-108.0MHz/100kHz HIGH AM: 531-1611kHz/9kHz FM: 87.5-108.0MHz/50kHz

AMP ADJUSTMENT

Confirmation of Idling Current of Main (1) P. C. B.

- Right after power is turned on, confirm that the voltage across the terminals of R113 (Main Lch), R133 (Main Rch), R187 (Center), R151 (Rear Lch), R169 (Rear Rch) are between 0.1mV and 10.0mV.
- If it exceeds 10.0mV, open (cutoff) R106 (Main Lch), R126 (Main Rch), R183 (Center), R146 (Rear Lch), R164 (Rear Rch) and reconfirm the voltage.
- Confirm that the voltage is 0.2mV ~ 15.0mV after 60 minutes.

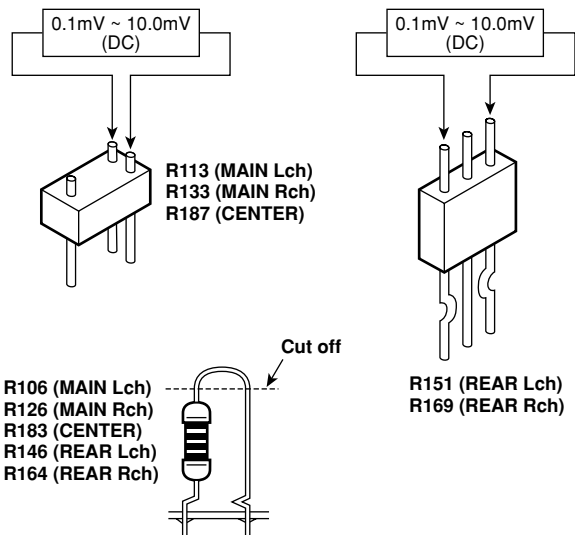

■ DISPLAY DATA

● V701 : HNA-16MM37 (V8300400)

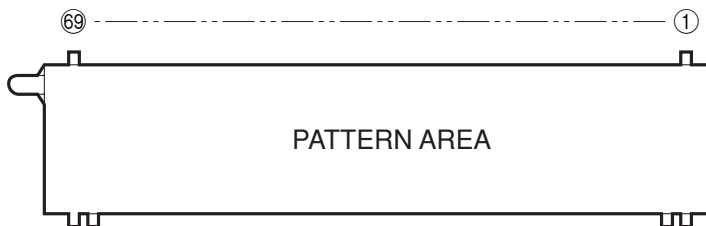

● PIN CONNECTION

Pin No.	69	68	67	66	65	64	63	62	61	60	59	58	57	56	55	54	53	52	51	50	49	48	47	46	45	44	43	42	41	40	39	38	37	36	35
Connection	F2	F2	NP	NP	P1	P2	P3	P4	P5	P6	P7	P8	P9	P10	P11	P12	P13	P14	P15	P16	P17	P18	P19	P20	P21	P22	P23	P24	P25	P26	P27	P28	P29	P30	P31
Pin No.	34	33	32	31	30	29	28	27	26	25	24	23	22	21	20	19	18	17	16	15	14	13	12	11	10	9	8	7	6	5	4	3	2	1	
Connection	P32	P33	P34	P35	P36	P37	NX	NX	NX	NX	NX	NX	NX	NX	G16	G15	G14	G13	G12	G11	G10	G9	G8	G7	G6	G5	G4	G3	G2	G1	NP	NP	F1	F1	

Note : 1) F1, F2 Filament 2) NP No pin 3) G1 ~ 16 Grid 4) NX No extended 5) P1 ~ 37 Anode

● GRID ASSIGNMENT

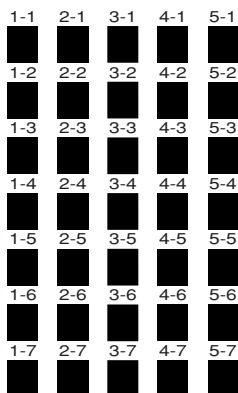
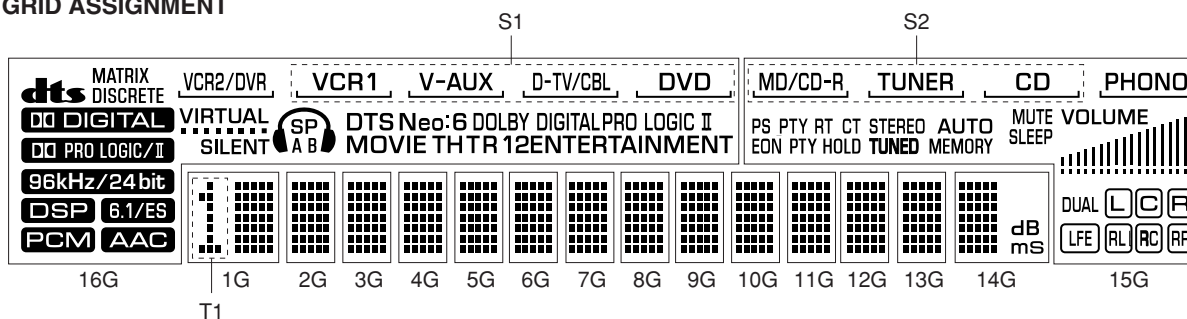



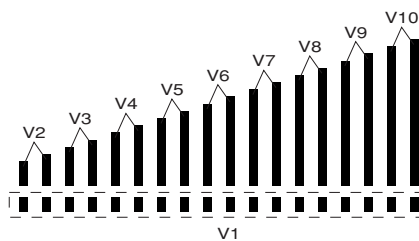













(1G~14G)



(15G)

● ANODE CONNECTION

	16G	15G	14G	13G~2G	1G
P1		S2	1-1	1-1	1-1
P2	MATRIX	PHONO	2-1	2-1	2-1
P3	DISCRETE	(MD/CD-R)	3-1	3-1	3-1
P4		(TUNER)	4-1	4-1	4-1
P5		(CD)	5-1	5-1	5-1
P6		(PHONO)	1-2	1-2	1-2
P7		PS	2-2	2-2	2-2
P8		PTY	3-2	3-2	3-2
P9		RT	4-2	4-2	4-2
P10		CT	5-2	5-2	5-2
P11	VIRTUAL	EON	1-3	1-3	1-3
P12	SILENT	PTY HOLD	2-3	2-3	2-3
P13		STEREO	3-3	3-3	3-3
P14	SP	AUTO	4-3	4-3	4-3
P15	A	TUNED	5-3	5-3	5-3
P16	B	MEMORY	1-4	1-4	1-4
P17	DTS	MUTE	2-4	2-4	2-4
P18	Neo:6	SLEEP	3-4	3-4	3-4
P19	DOLBY	VOLUME	4-4	4-4	4-4
P20	DIGITAL	V1	5-4	5-4	5-4
P21	PRO LOGIC	V2	1-5	1-5	1-5
P22	II	V3	2-5	2-5	2-5
P23	MOVIE THTR	V4	3-5	3-5	3-5
P24	1 (2)	V5	4-5	4-5	4-5
P25	2	V6	5-5	5-5	5-5
P26	ENTERTAINMENT	V7	1-6	1-6	1-6
P27	S1	V8	2-6	2-6	2-6
P28	(VCR2/DVR)	V9	3-6	3-6	3-6
P29	(VCR) 1	V10	4-6	4-6	4-6
P30	(VCR2/DVR)	DUAL	5-6	5-6	5-6
P31	(VCR1)		1-7	1-7	1-7
P32	(V-AUX)		2-7	2-7	2-7
P33	(D-TV/CBL)		3-7	3-7	3-7
P34	(DVD)		4-7	4-7	4-7
P35	–		5-7	5-7	5-7
P36	–		dB	–	T1
P37	–		mS	–	–

IC DATA

IC301: M30624FGAFP (FUNCTION P.C.B.)
16bit μ -COM (Main CPU)

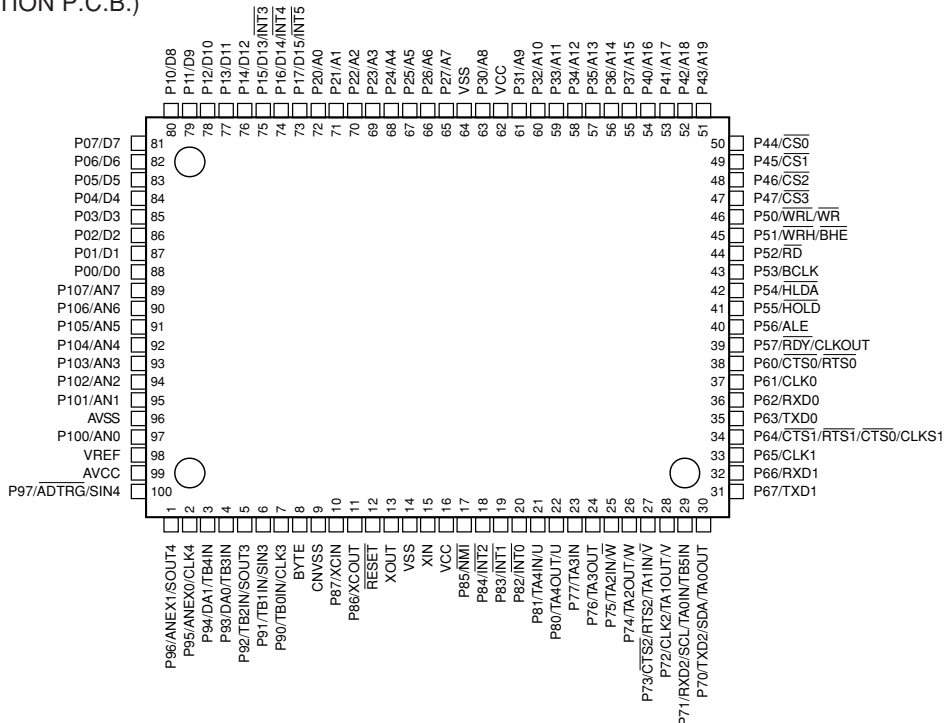

No.	Port No.	Function name	I/O	Detail of function
1	SOUT4	DTEV	SO	Electronic Volume IC DATA
2	CLK4	CLEV	SCK	Electronic Volume IC CLOCK
3	DA1	FAN	DA	Fan Control
4	P93	PRI	I	Protection Excess Current Detect
5	SOUT3	SDM	SO	YSS938 TxD
6	SIN3	SDD	SI	YSS938 RxD
7	CLK3	SCK	O	YSS938 CLOCK
8	BYTE	BYTE	VSS	Vss: when single chip mode is used
9	CNVss	CNVss	Vss/Vcc	Vss: when single chip mode is used, Vcc: when flash writing is used
10	P87	RIMA	O	Power Limiter A
11	P86	RIMB	O	Power Limiter B
12	RESET	RESET	I	Reset
13	Xout	Xout	OPEN	Oscillator Out
14	Vss	Vss	Vss	μ -COM Ground
15	Xin	Xin	10MHz	Oscillator in
16	Vcc	Vcc	Vcc (BU)	μ -COM power supply, +5V
17	NMI	NMI	Vcc (BU)	Connect to Vcc because it is unused.
18	INT2	VSY	INT	Vertical Synchronization Detect
19	INT1	INT938	INT	YSS938 IPINT/MUTE/DIR
20	P82	ERY	O	Effect SP Relay Output
21	P81	MRY	O	Main SP Relay Output
22	P80	HPRY	SO	Headphone Relay Output
23	P77	/HP	I (IPU)	Effect Detect
24	P76	PRY	O	Power Relay Output
25	P75	DMT	O	DIG FULL MUTE
26	P74	/ICD	O	YSS938 /DA /AD /CODEC /DEM
27	P73	CSY	O	YSS938 CE
28	CLK2	SCK0	O	FL Driver CLOCK
29	RXD2	/CSINT	I	CS-DSP INT
30	TXD2	SDF	O	FL Driver TxD
31	TXD1	TXDF	FLASH	Flash ROM Serial Write Data Transmission
32	RXD1	RXDF	FLASH	Flash ROM Serial Write Data Reception
33	CLK1	CLKF	FLASH	Flash ROM Serial Clock
34	P64	BSY	FLASH	Flash BUSY Signal Output
35	TXD0	SDTR	SO	RDS/OSD TxD
36	RXD0	SDRR	SI	RDS RxD
37	CLK0	SCKR	SCK	RDS/OSD CLOCK
38	P60		O	EEPROM CE
39	P57	CST	I	CS493x TxD
40	P56	CSR	O	CS493x RxD
41			GND	For Flash Writing (LO)
42	P54	CSC	O	CS493x CLOCK
43	P53	/CSCS	O	CS493x CS

IC301: M30624FGAFP (FUNCTION P.C.B.)
 16bit μ -COM (Main CPU)

No.	Port No.	Function name	I/O	Detail of function
44	P52	/ICCS	O	CS493x RESET
45	P51	/CSOLD	O	DIG EXTERNAL CONTROL IC CE
46			I	For Flash Writing (HI)
47	P47	CSN	O	Chip Select for DAC
48	P46	VRB	I	Volume Rotary B
49	P45	VRA	I	Volume Rotary A
50	P44	/BLK	O	FL Driver Light Off (Reset)
51	P43	SDTP	SO	PLL IC TxD
52	P42	SDRP	SI	PLL IC RxD
53	P41	SCKP	SCK	PLL IC CLOCK
54	P40	CEFD	O	FL Driver CE
55	P37	/ST	I (IPU)	Tuner Stereo
56	P36	TMT	O	Tuner Mute
57	P35	TUNED	I (IPU)	Tuner Tuned
58	P34	RDSE	O/I (IPU)	RDS Enable/RDS Present/Absent
59	P33	CEP	O	PLL IC Chip Enable
60	P32	DEST	I (IPU)	FREQ SW (R Ver)
61	P31	I/E	O	External/Internal Synchronization Output
62	Vcc	Vcc	Vcc (BU)	Microprocessor Power Supply, +5V
63	P30	CES	O/I (IPU)	OSD Enable/ N/P Format
64	Vss	Vss	Vss	Microprocessor Ground
65	P27	CMP1	O	Component Selector 1
66	P26	CMP0	O	Component Selector 0
67	P25	/VR2	O	VIDEO Rec Out Selector 2
68	P24	/VR1	O	VIDEO Rec Out Selector 1
69	P23	VIC	O	VIDEO Selector C
70	P22	VIB	O	VIDEO Selector B
71	P21	VIA	O	VIDEO Selector A
72	P20			Open
73	INT5	REM1	INT	Remote Control Input
74	INT4	PSW	INT	Standby SW Input
75	INT3	PDET	INT	Power Down Detect INT
76	P14	/MTMR	O	Mute Main /Rear
77	P13	/MTCT	O	Mute Center
78	P12	/MTSW	O	Mute LFE
79	P11	TUN0	I (IPU)	Tuner Destination Identify 0
80	P10	TUN1	I (IPU)	Tuner Destination Identify 1
81	P07	CELC	O	CE for SANYO IC
82	P06	SDT	O	Audio IC Data
83	P05	SCK	O	Audio IC Clock
84	P04	/SWMIX	O	LFE Mix
85	P03	/CTMIX	O	Center Mix
86	P02	SEEV	O	Electronic Volume IC Chip Enable
87	P01	ICN	O	Electronic Volume Reset
88	P00	A2GAIN	O	For A2 Gain Setting
89	AN7	MODEL	AD	Model Identification
90	AN6	ADKEY2	AD	Key AD Input 2
91	AN5	ADKEY1	AD	Key AD Input 1
92	AN4	ADKEY0	AD	Key AD Input 0
93	AN3	THM	AD	Temperature Detect
94	AN2	PRV	AD	Protection Power Supply Voltage Detect
95	AN1	PREMT	AD	Power Limiter Detect
96	Avss	Avss	Vss	AD Ground
97	AN0	PRD	I	Protection DC Detect
98	Vref	Vref	(+5v)	AD Reference
99	Avcc	Avcc	Vcc (BU)	AD Power Supply
100	P97	PRD	AD	DC Protection

IC600 : YSS938-F
DSP

YSS938-F

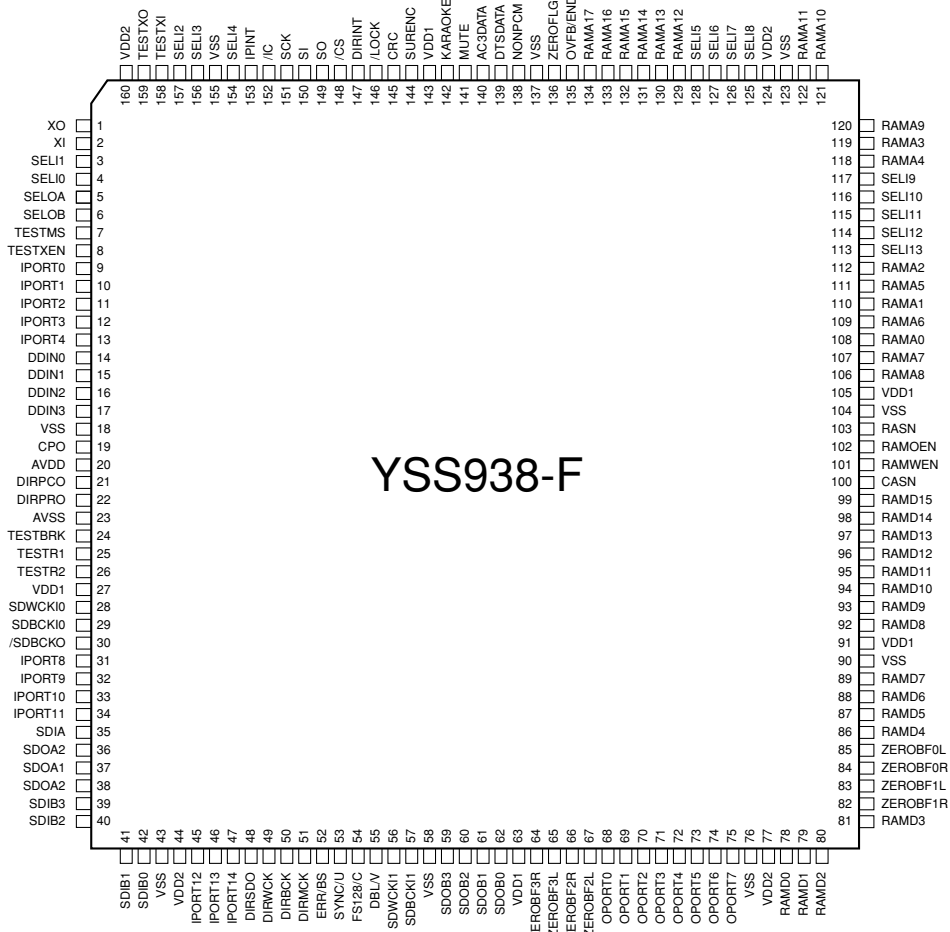
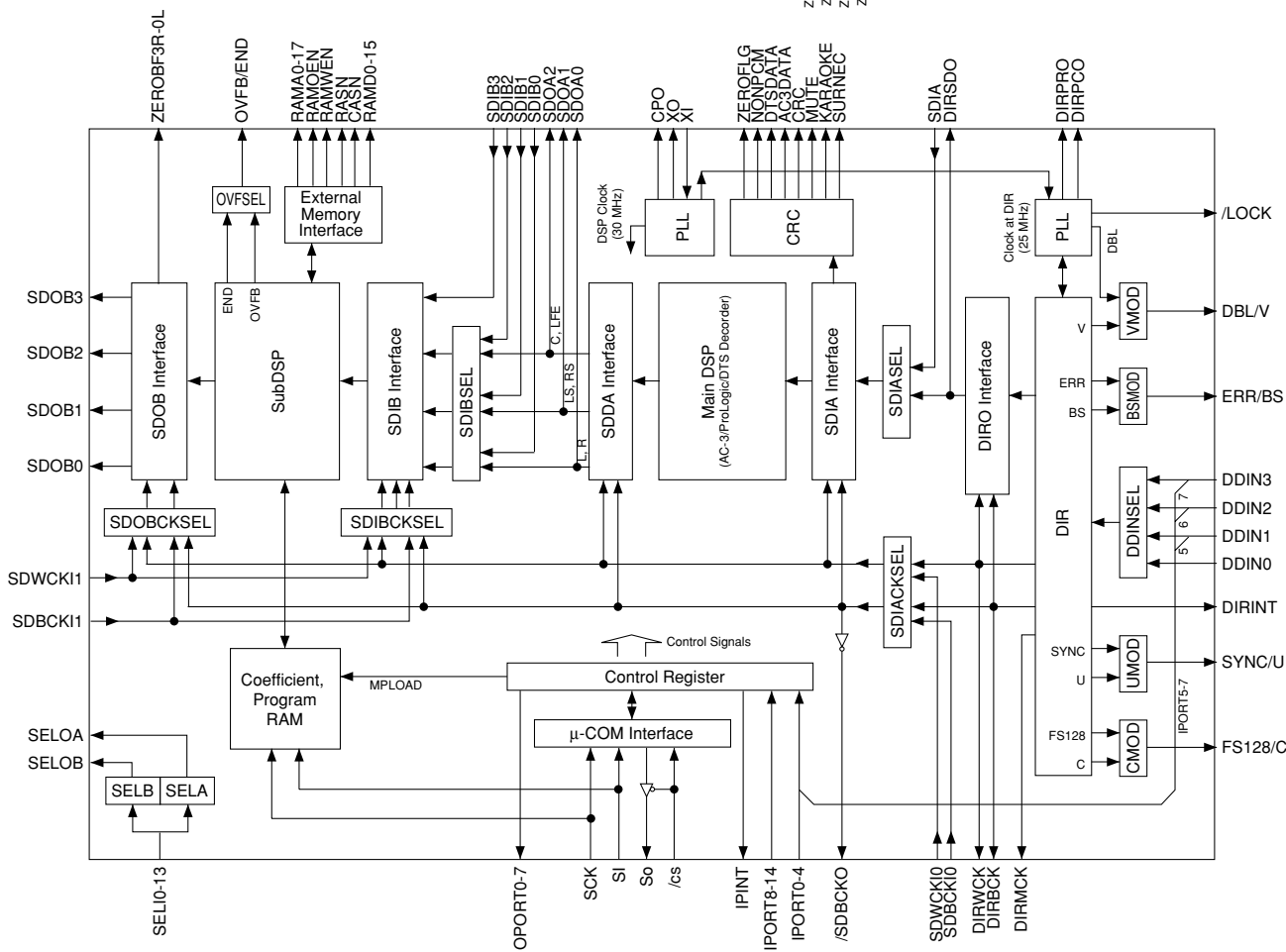

IC600 : YSS938-F
DSP

No.	Name	I/O	Function
1	XO	O	Crystal oscillator connecting terminal
2	XI	I	Crystal oscillator connecting terminal (24.576MHz)
3	SEL11	I+	Built-in selector input 1 (AXD)
4	SEL10	I+	Built-in selector input 0 (GND)
5	SELOA	O+	Built-in selector output A (ISEL)
6	SELOB	O+	Built-in selector output B (RSEL)
7	TESTMS	I+	Test terminal (unconnected)
8	TESTXEN	I+	Test terminal (unconnected)
9	IPORT0	I+	General purpose input terminal (CXDTA)
10	IPORT1	I+	General purpose input terminal (CXDTB)
11	IPORT2	I+	General purpose input terminal
12	IPORT3	I+	General purpose input terminal
13	IPORT4	I+	General purpose input terminal
14	DDIN0	Is	DIR: Digital audio interface data input terminal 0 (ISEL)
15	DDIN1	Is	DIR: Digital audio interface data input terminal 1/General purpose input terminal (Pull down)
16	DDIN2	Is	DIR: Digital audio interface data input terminal 2/General purpose input terminal (Pull down)
17	DDIN3	Is	DIR: Digital audio interface data input terminal 3/General purpose input terminal (Pull down)
18	VSS		Ground terminal
19	CPO	A	PLL filter connecting terminal
20	AVDD		+3.3V power terminal (for DIR)
21	DIRPCO	A	DIR: PLL filter connecting terminal
22	DIRPRO	A	DIR: PLL filter connecting terminal
23	AVSS		Ground terminal (for DIR)
24	TESTBRK	I+	Test terminal (unconnected)
25	TESTR1	I+	PLL initialization signal input terminal for DSP (/ICD)
26	TESTR2	I+	Test terminal (unconnected)
27	VDD1		+3.3V power terminal (for terminal section)
28	SDWCKI0	I+	Word clock input terminal for SDIA, SDOA, SDIB, SDOB interface (Unconnected)
29	SDBCKI0	I+	Bit clock input terminal for SDIA, SDOA, SDIB, SDOB interface (Unconnected)
30	/SDBCK0	O	DIRBCK or SDBCKI0 invert clock output terminal (Unconnected)
31	IPORT8	I+	IPINT general purpose input terminal
32	IPORT9	I+	IPINT general purpose input terminal
33	IPORT10	I+	IPINT general purpose input terminal (NONPCM)
34	IPORT11	I+	IPINT general purpose input terminal (NONPCM)
35	SDIA	I	AC-3/DTS bit stream (or PCM) data input terminal to Main DSP (SDIA)
36	SDOA2	O	PCM output terminal from Main DSP (C/LFE output) (Unconnected)
37	SDOA1	O	PCM output terminal from Main DSP (LS/RS output) (Unconnected)
38	SDOA0	O	PCM output terminal from Main DSP (L/R output)
39	SDIB3	I+	PCM input terminal 3 to Sub DSP
40	SDIB2	I+	PCM input terminal 2 to Sub DSP
41	SDIB1	I+	PCM input terminal 1 to Sub DSP
42	SDIB0	I+	PCM input terminal 0 to Sub DSP
43	VSS		Ground terminal
44	VDD2		+2.5V power terminal (for internal circuit)
45	IPORT12	I+	IPINT general purpose input terminal (MUTE)
46	IPORT13	I+	IPINT general purpose input terminal (DIRINT)
47	IPORT14	I+	IPINT general purpose input terminal (Unconnected)
48	DIRSDO	O	AC-3/DTS bit stream (or PCM) data output terminal from DIR
49	DIRWCK	O	DIR: Serial data word clock (fs) output terminal (WCK)
50	DIRBCK	O	DIR: Serial data bit clock (64fs) output terminal (BCK)
51	DIRMCK	O	DIR: Serial data master clock (256fs or 128fs) output terminal (MCK)
52	ERR/BS	O	DIR: Data error detect output/block start output terminal (Unconnected)
53	SYNC/U	O	DIR: Serial data synchronous timing output/user data output terminal (Unconnected)
54	FS128/C	O	DIR: Serial data master clock 128fs output/channel status output terminal (Unconnected)
55	DBL/V	O	DIR: Double rate clock output/validity flag output terminal (DBL)

IC600 : YSS938-F
 DSP

No.	Name	I/O	Function
56	SDWCKI1	I+	Word clock input terminal for SDIB, SDOB interface (Unconnected)
57	SDBCKI1	I+	Bit clock input terminal for SDIB, SDOB interface (Unconnected)
58	VSS		Ground terminal
59	SDOB3	O	PCM output terminal from Sub DSP
60	SDOB2	O	PCM output terminal from Sub DSP
61	SDOB1	O	PCM output terminal from Sub DSP
62	SDOB0	O	PCM output terminal from Sub DSP
63	VDD1		+3.3V power terminal (for terminal section)
64	ZEROBF3R	O+	SDOB3 Rch zero flag output terminal (ZF3R)
65	ZEROBF3L	O+	SDOB3 Lch zero flag output terminal (ZF3L)
66	ZEROBF2R	O+	SDOB2 Rch zero flag output terminal (ZF2R)
67	ZEROBF2L	O+	SDOB2 Lch zero flag output terminal (ZF2L)
68	OPORT0	O	General purpose output terminal (/RINH1)
69	OPORT1	O	General purpose output terminal (/RINH2)
70	OPORT2	O	General purpose output terminal (/ICCDC)
71	OPORT3	O	General purpose output terminal (DFS)
72	OPORT4	O	General purpose output terminal (ZSEL0)
73	OPORT5	O	General purpose output terminal (ZSEL1)
74	OPORT6	O	General purpose output terminal (/ICCS)
75	OPORT7	O	General purpose output terminal
76	VSS		Ground terminal
77	VDD2		+2.5V power terminal (for internal circuit)
78	RAMD0	I+/O	Sub DSP: External memory data terminal 0
79	RAMD1	I+/O	Sub DSP: External memory data terminal 1
80	RAMD2	I+/O	Sub DSP: External memory data terminal 2
81	RAMD3	I+/O	Sub DSP: External memory data terminal 3
82	ZEROBF1R	O+	SDOB1 Rch zero flag output terminal (ZF1R)
83	ZEROBF1L	O+	SDOB1 Lch zero flag output terminal (ZF1L)
84	ZEROBF0R	O+	SDOB0 Rch zero flag output terminal (ZF0R)
85	ZEROBF0L	O+	SDOB0 Lch zero flag output terminal (ZF0L)
86	RAMD4	I+/O	Sub DSP: External memory data terminal 4
87	RAMD5	I+/O	Sub DSP: External memory data terminal 5
88	RAMD6	I+/O	Sub DSP: External memory data terminal 6
89	RAMD7	I+/O	Sub DSP: External memory data terminal 7
90	VSS		Ground terminal
91	VDD1		+3.3V power terminal (for terminal section)
92	RAMD8	I+/O	Sub DSP: External memory data terminal 8
93	RAMD9	I+/O	Sub DSP: External memory data terminal 9
94	RAMD10	I+/O	Sub DSP: External memory data terminal 10
95	RAMD11	I+/O	Sub DSP: External memory data terminal 11
96	RAMD12	I+/O	Sub DSP: External memory data terminal 12
97	RAMD13	I+/O	Sub DSP: External memory data terminal 13
98	RAMD14	I+/O	Sub DSP: External memory data terminal 14
99	RAMD15	I+/O	Sub DSP: External memory data terminal 15
100	CASN	O	Sub DSP: Column address strobe output terminal for external DRAM
101	RAMWEN	O	Sub DSP: Write enable terminal for external memory
102	RAMOEN	O	Sub DSP: Output enable terminal for external memory
103	RASN	O	Sub DSP: Low address strobe output terminal for external DRAM
104	VSS		Ground terminal
105	VDD1		+3.3V power terminal (for terminal section)
106	RAMA8	O	Sub DSP: External memory address terminal 8
107	RAMA7	O	Sub DSP: External memory address terminal 7
108	RAMA0	O	Sub DSP: External memory address terminal 0
109	RAMA6	O	Sub DSP: External memory address terminal 6
110	RAMA1	O	Sub DSP: External memory address terminal 1

IC600 : YSS938-F
DSP

No.	Name	I/O	Function
111	RAMA5	O	Sub DSP: External memory address terminal 5
112	RAMA2	O	Sub DSP: External memory address terminal 2
113	SELI13	I+	Built-in selector input 13 (Unconnected)
114	SELI12	I+	Built-in selector input 12
115	SELI11	I+	Built-in selector input 11 (Unconnected)
116	SELI10	I+	Built-in selector input 10 (Unconnected)
117	SELI9	I+	Built-in selector input 9
118	RAMA4	O	Sub DSP: External memory address terminal 4
119	RAMA3	O	Sub DSP: External memory address terminal 3
120	RAMA9	O	Sub DSP: External memory address terminal 9 (Unconnected)
121	RAMA10	O	Sub DSP: External memory address terminal 10 (Unconnected)
122	RAMA11	O	Sub DSP: External memory address terminal 11 (Unconnected)
123	VSS		Ground terminal
124	VDD2		+2.5V power terminal (for internal circuit)
125	SELI8	I+	Built-in selector input 8 (CXA)
126	SELI7	I+	Built-in selector input 7 (GND)
127	SELI6	I+	Built-in selector input 6 (OPTF)
128	SELI5	I+	Built-in selector input 5 (Unconnected)
129	RAMA12	O	Sub DSP: External memory address terminal 12 (Unconnected)
130	RAMA13	O	Sub DSP: External memory address terminal 13 (Unconnected)
131	RAMA14	O	Sub DSP: External memory address terminal 14 (Unconnected)
132	RAMA15	O	Sub DSP: External memory address terminal 15 (Unconnected)
133	RAMA16	O	Sub DSP: External memory address terminal 16 (Unconnected)
134	RAMA17	O	Sub DSP: External memory address terminal 17 (Unconnected)
135	OVFB/END	O	Sub DSP: Overflow/program end detect terminal (Unconnected)
136	ZEROF LG	O	Main DSP: Zero flag output terminal (Unconnected)
137	VSS		Ground terminal
138	NONPCM	O	Main DSP: Non-PCM data detect terminal
139	DTSDATA	O	Main DSP: DTS data detect terminal (Unconnected)
140	AC3DATA	O	Main DSP: AC3 data detect terminal (Unconnected)
141	MUTE	O	Main DSP: Auto mute detect terminal
142	KARAOKE	O	Main DSP: AC3 KARAOKE data detect terminal (Unconnected)
143	VDD1	+3.3V	power terminal (for terminal section)
144	SURENC	O	Main DSP: AC-3 2/0 mode Dolby surround encode input detect terminal (Unconnected)
145	CRC	O	Main DSP: AC3 CRC error detect terminal (Unconnected)
146	/LOCK	O	DIR: PLL lock detect terminal (Unconnected)
147	DIRINT	O	DIR: Interrupt output terminal
148	/CS	Is	Microprocessor interface chip select input terminal (CSY)
149	SO	Ot	Microprocessor interface data output terminal
150	SI	Is	Microprocessor interface data input terminal (SDM)
151	SCK	Is	Microprocessor interface clock input terminal (SCKY)
152	/IC	Is	Initial clear input terminal (/ICD)
153	IPINT	O+	Interrupt output terminal by IPORT 8-14
154	SELI4	I+	Built-in selector input 4 (OPTD)
155	VSS		Ground terminal
156	SELI3	I+	Built-in selector input 3 (OPTC)
157	SELI2	I+	Built-in selector input 2 (OPTB)
158	TESTXI	I	Test terminal (should be always connected to VSS)
159	TESTXO	O	Test terminal (Unconnected)
160	VDD2	+2.5V	power terminal (for internal circuit)

Is: Schmidt trigger input terminal
I+: Input terminal with pull-up resistor
O: Digital output terminal
Ot: 3-state digital output terminal
A: Analog terminal

1 ■ BLOCK DIAGRAM (1/2)

2

3

4

5

6

7

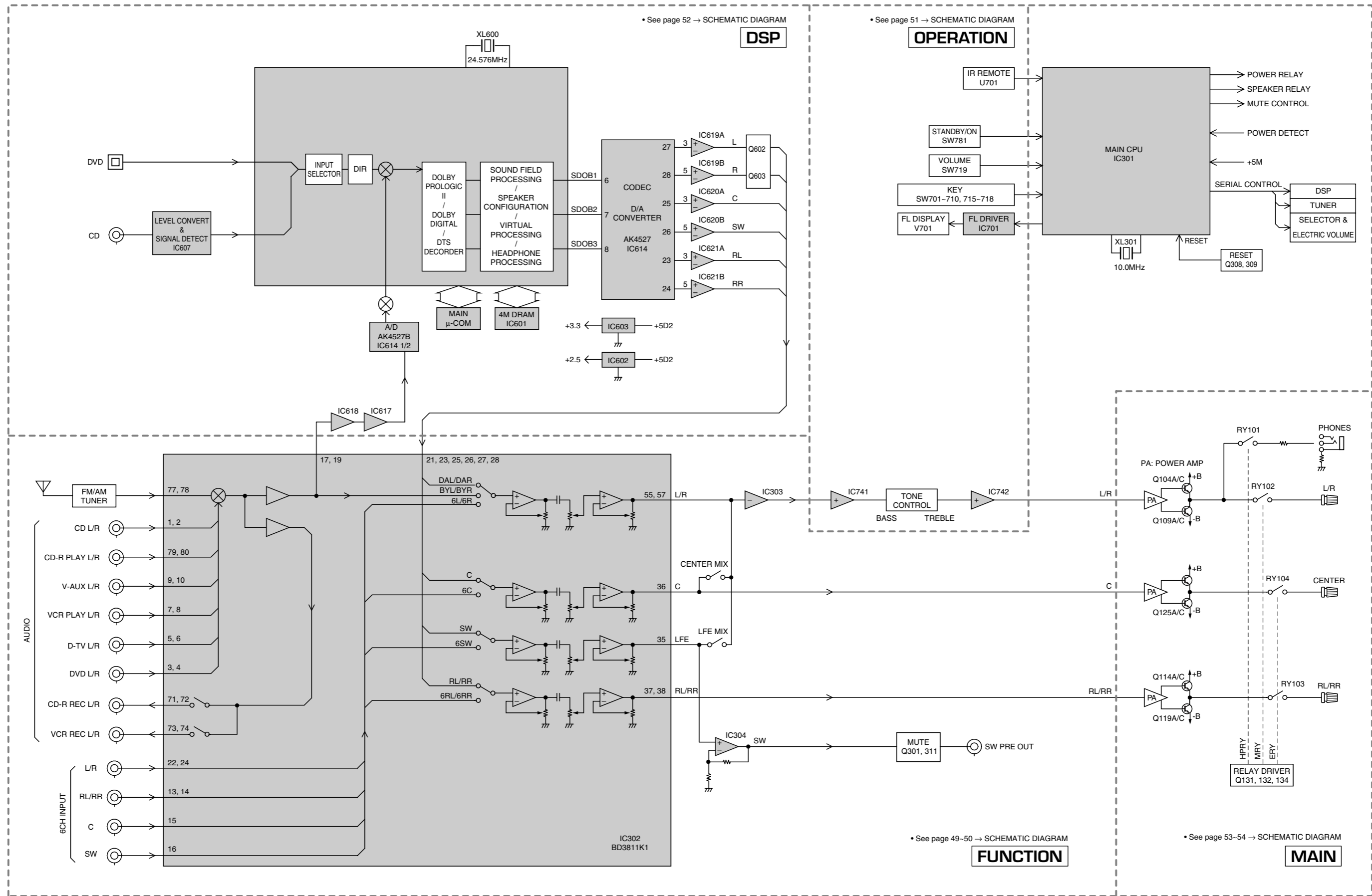

BLOCK DIAGRAM (2/2)

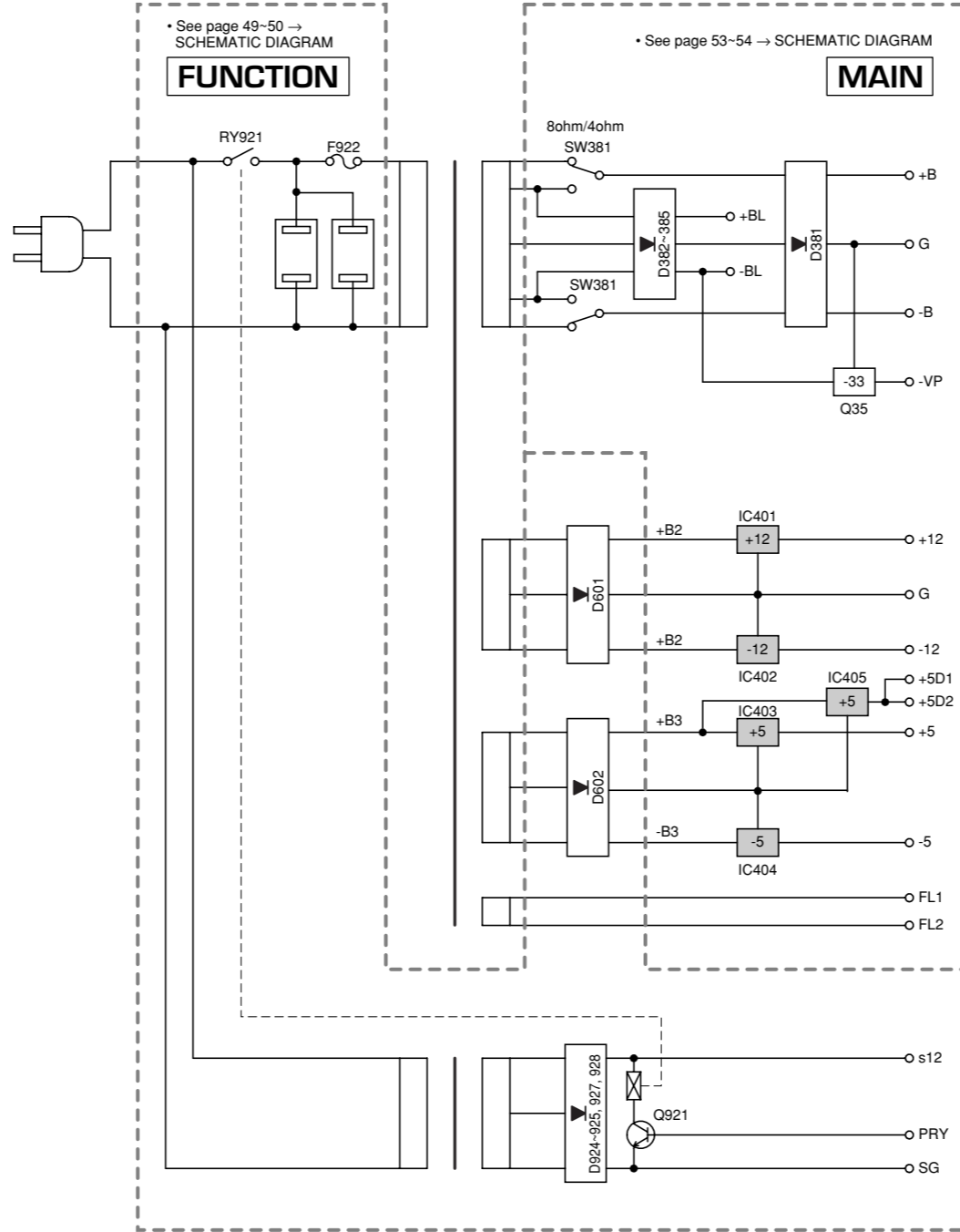
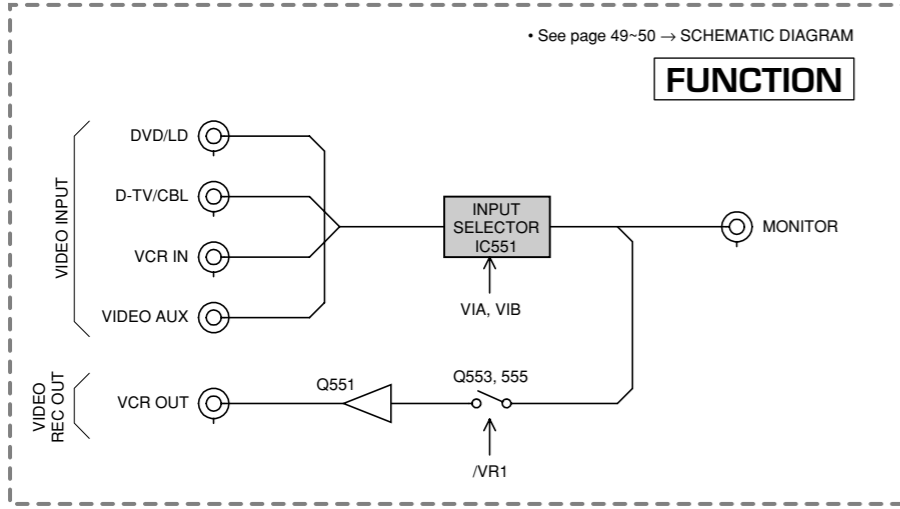

1 **PRINTED CIRCUIT BOARD (Foil side)**

Circuit No.	
J305	O
J306	X
X: NOT USED	
O: USED / APPLICABLE	

• Semiconductor Location

Ref. No.	Location
IC306	G4
Q304	D3
Q305	E3

FUNCTION (1) P. C. B. (Lead Type Device)

(Lead Type Device)

FUNCTION (4) : Not applied to HTR-5635

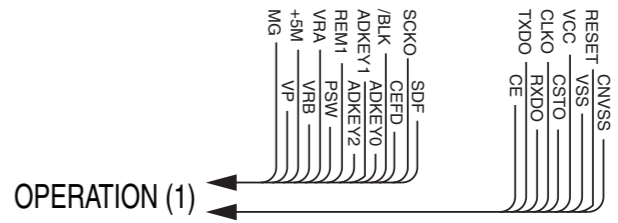
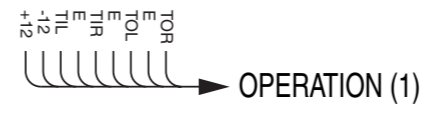
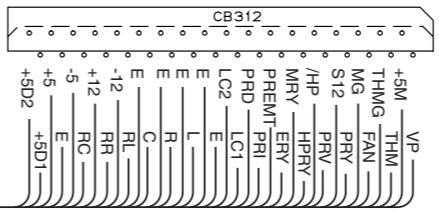
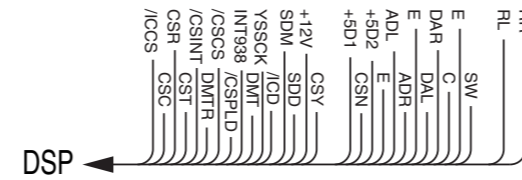
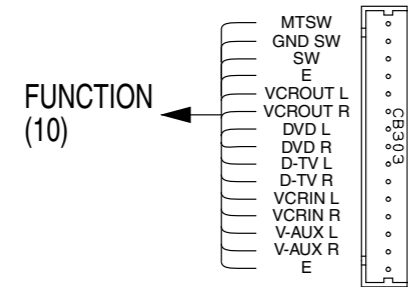
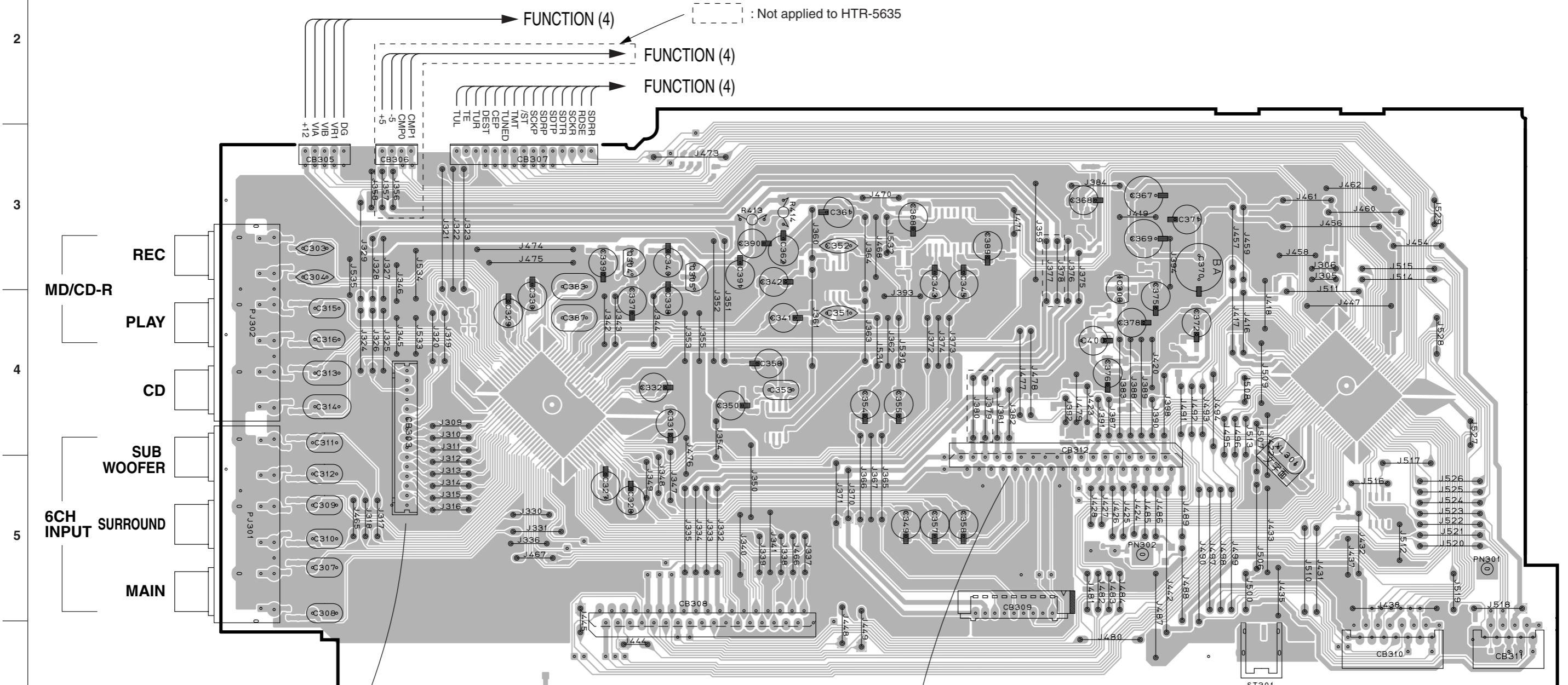

7

PRINTED CIRCUIT BOARD (Foil side)

FUNCTION (1) P. C. B. (Surface Mount Device)

• Semiconductor Location

Ref. No.	Location
D301	C2
D302	D2
D303	F3
D304	F3
D305	F3
D306	G3
D307	G3
D308	G3
D309	F3
D310	G3
D311	F3
D312	E2
D313	F2
D314	H5
D315	G5
IC301	H3
IC302	C3
IC303	E3
IC304	D3
IC305	E2
Q307	F2
Q308	G3
Q309	F3

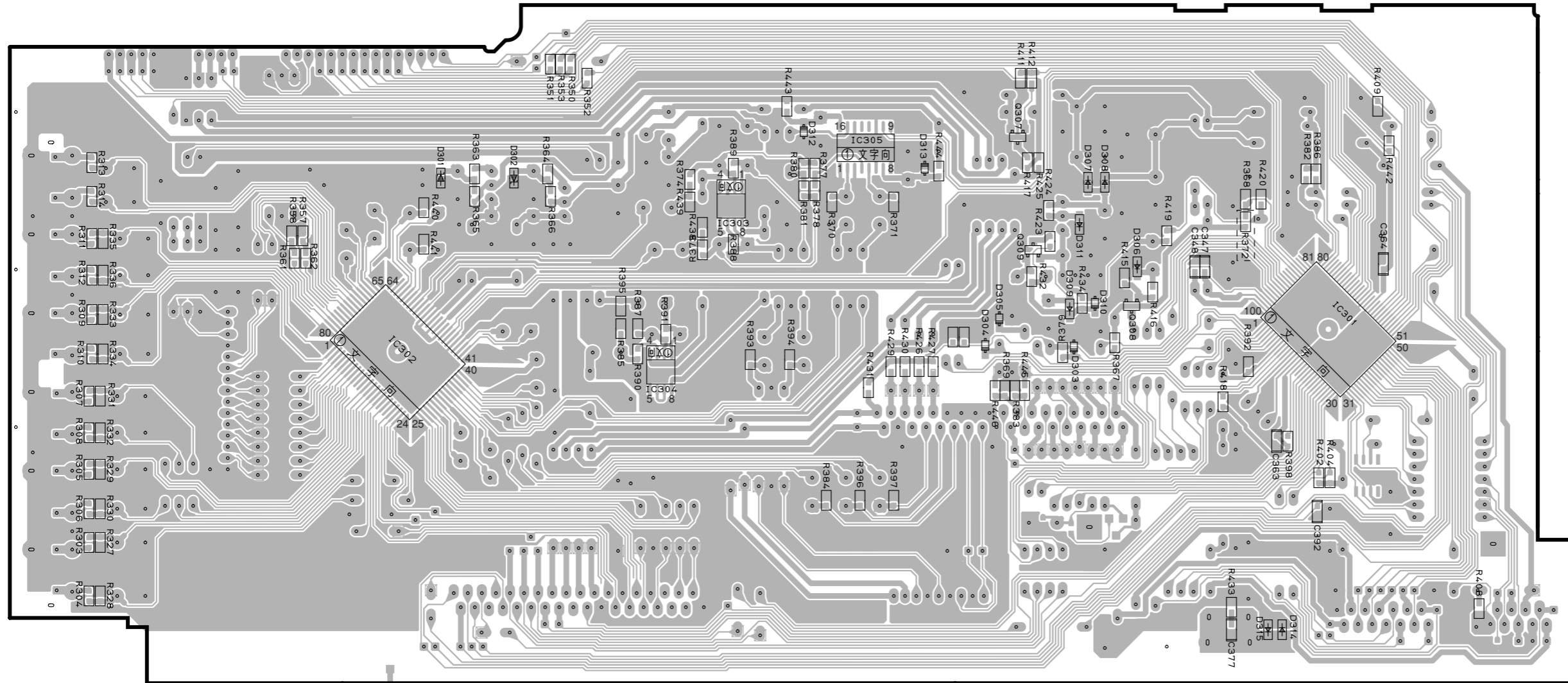

Circuit No.	
R382	X
R386	O
R409	O

X: NOT USED
O: USED / APPLICABLE

PRINTED CIRCUIT BOARD (Foil side)

FUNCTION (5) P. C. B.

(Lead Type Device)

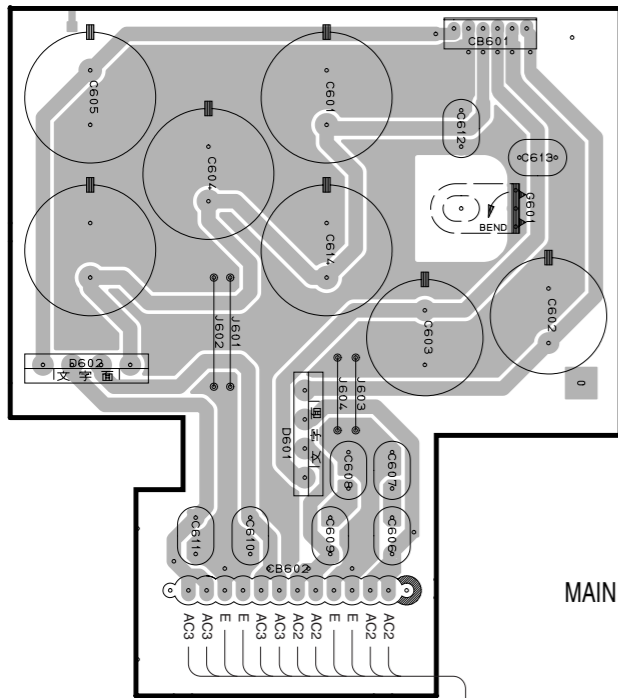

MAIN (4)

FUNCTION (7) P. C. B.

(Lead Type Device)

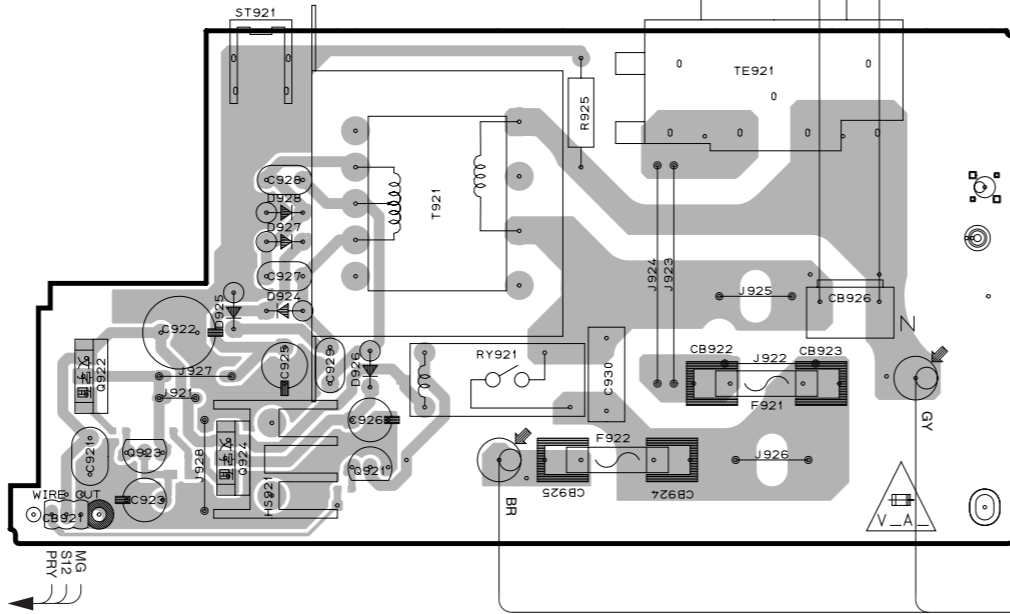

AC Power Cable

MAIN (2)

FUNCTION (7) P. C. B.

(Surface Mount Device)

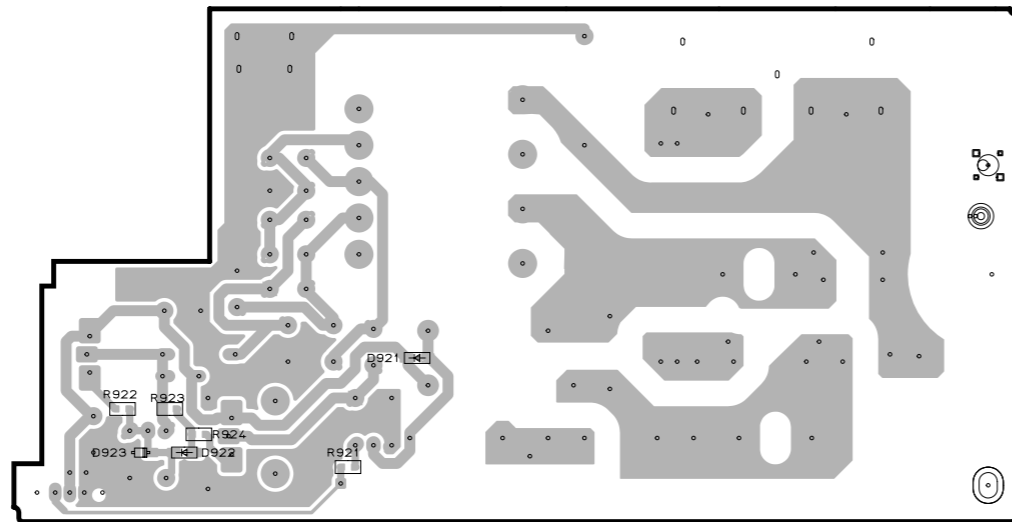

FUNCTION (9) P. C. B.

(Lead Type Device)

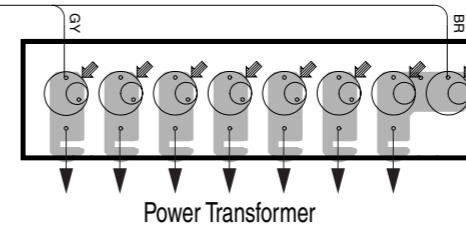

Power Transformer

FUNCTION (6) P. C. B.

(Lead Type Device)

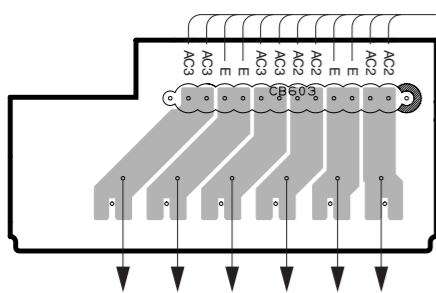

Power Transformer

FUNCTION (10) P. C. B. (Lead Type Device)

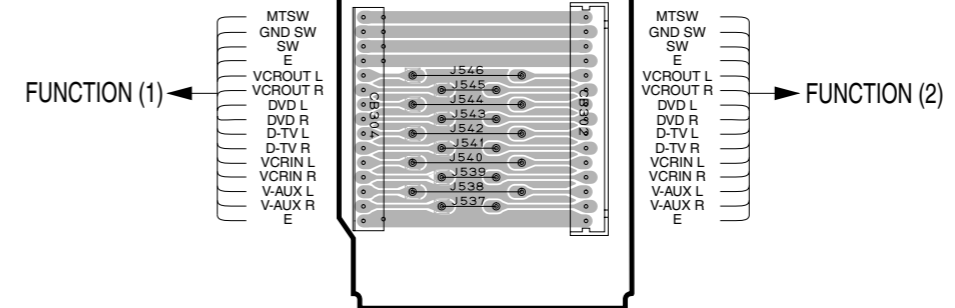

• Semiconductor Location

Ref. No.	Location
D601	B3
D602	A3
D921	D5
D922	C6
D923	C6
D924	D3
D925	D3
D926	D3
D927	D2
D928	D2
Q921	D3
Q922	D3
Q923	D3
Q924	D3

Circuit No.	
C923, 925, 926, 928, 929	X
C927	O
CB922, 923	X
CB941, 942	X
D922, 923, 925, 926	X
F921	X
F941	X
J921	O
J922	O
Q922-924	X
R922-924	X
R925	O
SW941	X
TE921	O
W941-946	X
W947	X

X: NOT USED
O: USED / APPLICABLE

PRINTED CIRCUIT BOARD (Foil side)

OPERATION (1) P. C. B. (Lead Type Device)

OPERATION (2) P. C. B. (Lead Type Device)

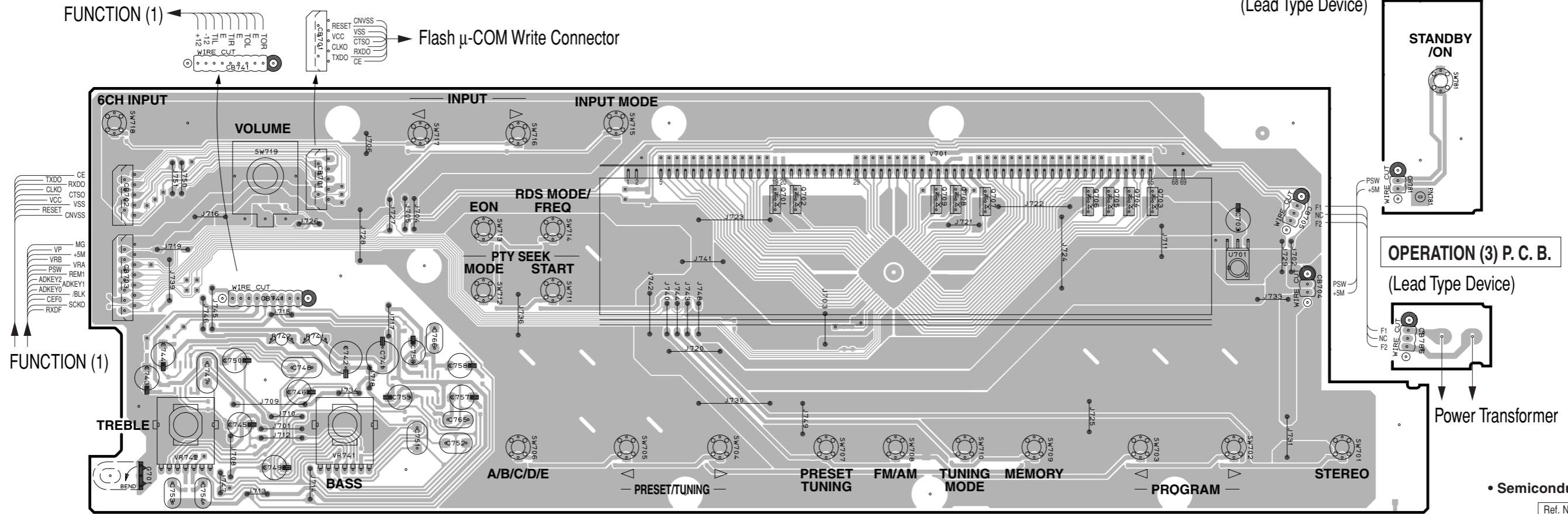

OPERATION (1) P. C. B. (Surface Mount Device)

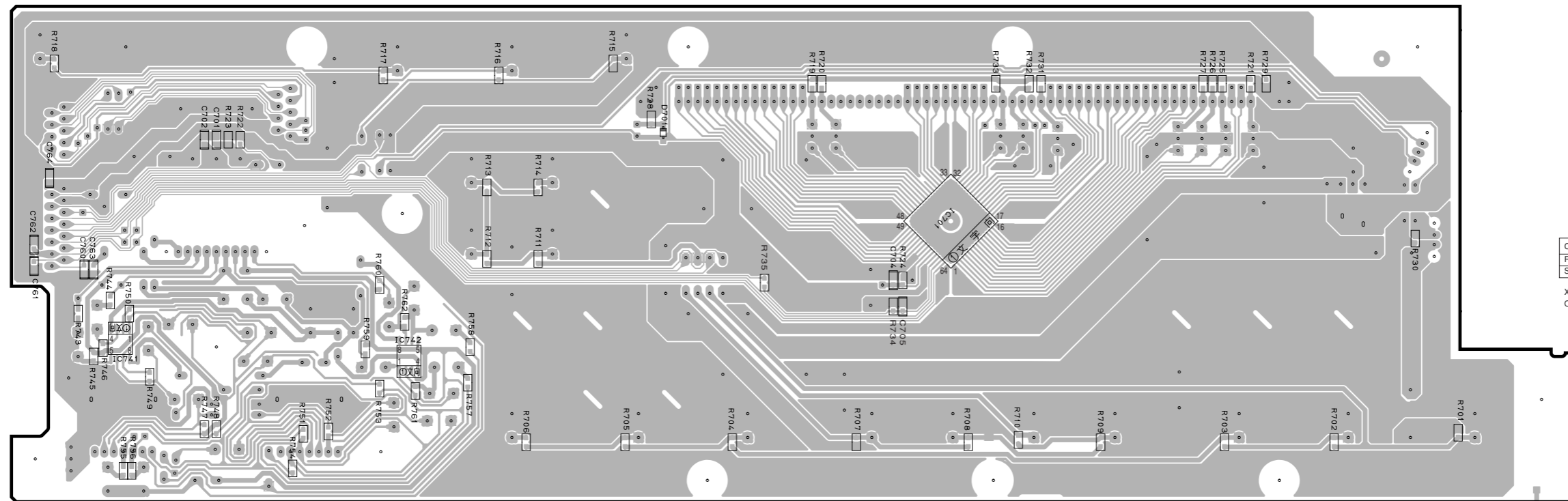

Semiconductor Location

Ref. No.	Location
D701	D5
IC701	F6
IC741	B6
IC742	C6
Q701	E3
Q702	E3
Q703	G3
Q704	G3
Q705	G3
Q706	G3
Q707	F3
Q708	F3
Q709	F3

Circuit No.	
R711-714	X
SW711-714	X

X: NOT USED
O: USED / APPLICABLE

PRINTED CIRCUIT BOARD (Foil side)

DSP P. C. B. (Lead Type Device)

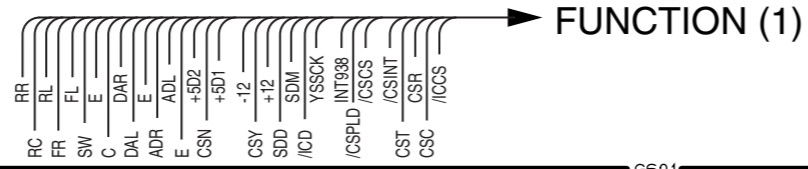

Circuit No.	
C658, 661, 666	X
J601	O
R653, 654, 656, 657, 659, 660, 662	X
R668	O

X: NOT USED
O: USED / APPLICABLE

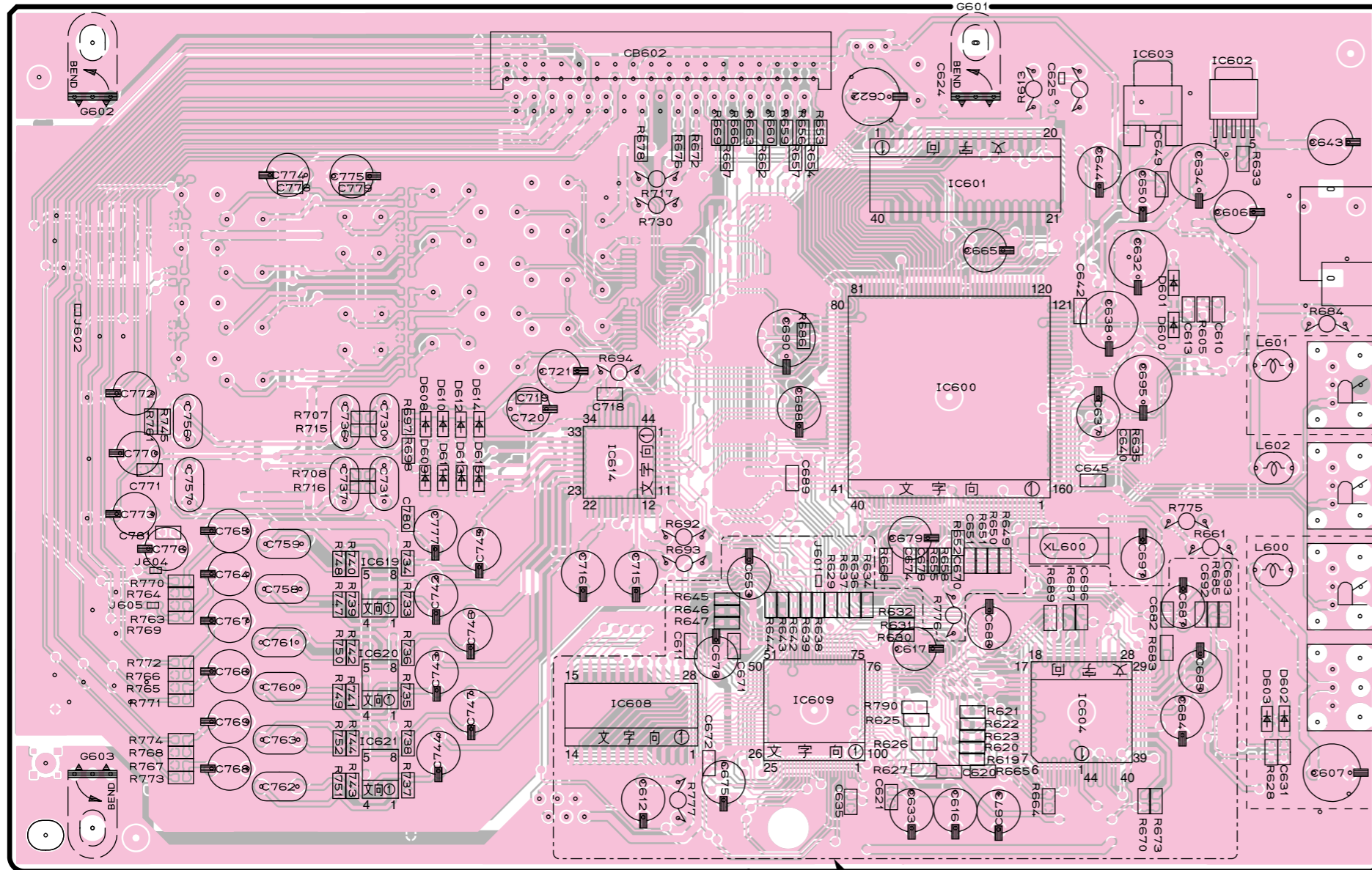

: Not applied to HTR-5635

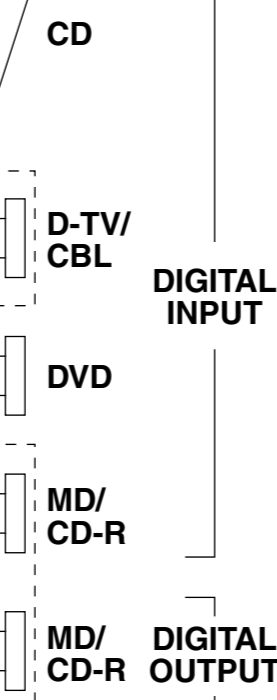

Semiconductor Location

Ref. No.	Location
D600	F3
D601	F3
D602	G5
D603	G5
D608	C4
D609	C4
D610	C4
D611	C4
D612	C4
D613	C4
D614	C4
D615	C4
IC600	E4
IC601	E3
IC602	F2
IC603	F2
IC604	F5
IC608	D5
IC609	E5
IC614	D4
IC619	C4
IC620	C5
IC621	C5

Not applied to HTR-5635

: Not applied to HTR-5635

1 ■ PRINTED CIRCUIT BOARD (Foil side)

DSP P. C. B. (Surface Mount Device)

Circuit No.	
C658, 661, 666	X
J601	O
R653, 654, 656, 657, 659, 660, 662	X
R668	O

X: NOT USED
O: USED / APPLICABLE

• Semiconductor Location

Ref. No.	Location
D604	F2
D605	F2
D606	F2
D607	F2
IC605	G5
IC606	G5
IC607	F3
IC610	F4
IC617	B4
IC618	B4
Q601	C4
Q602	A2
Q603	A3
Q604	C4

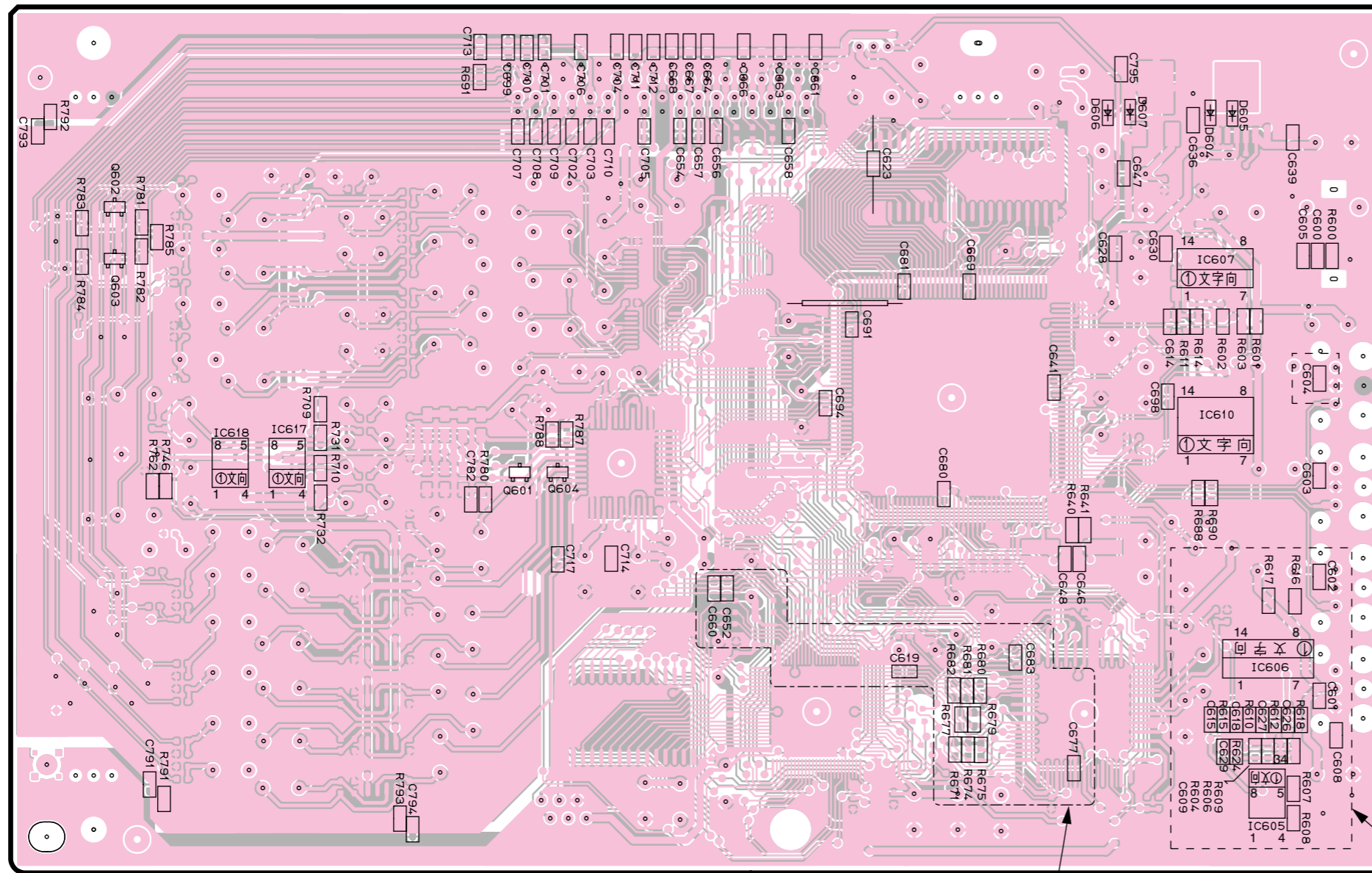

⋯ : Not applied to HTR-5635

⋯ : Not applied to HTR-5635

2

3

4

5

6

7

PRINTED CIRCUIT BOARD (Foil side)

MAIN (1) P. C. B.

(Lead Type Device)

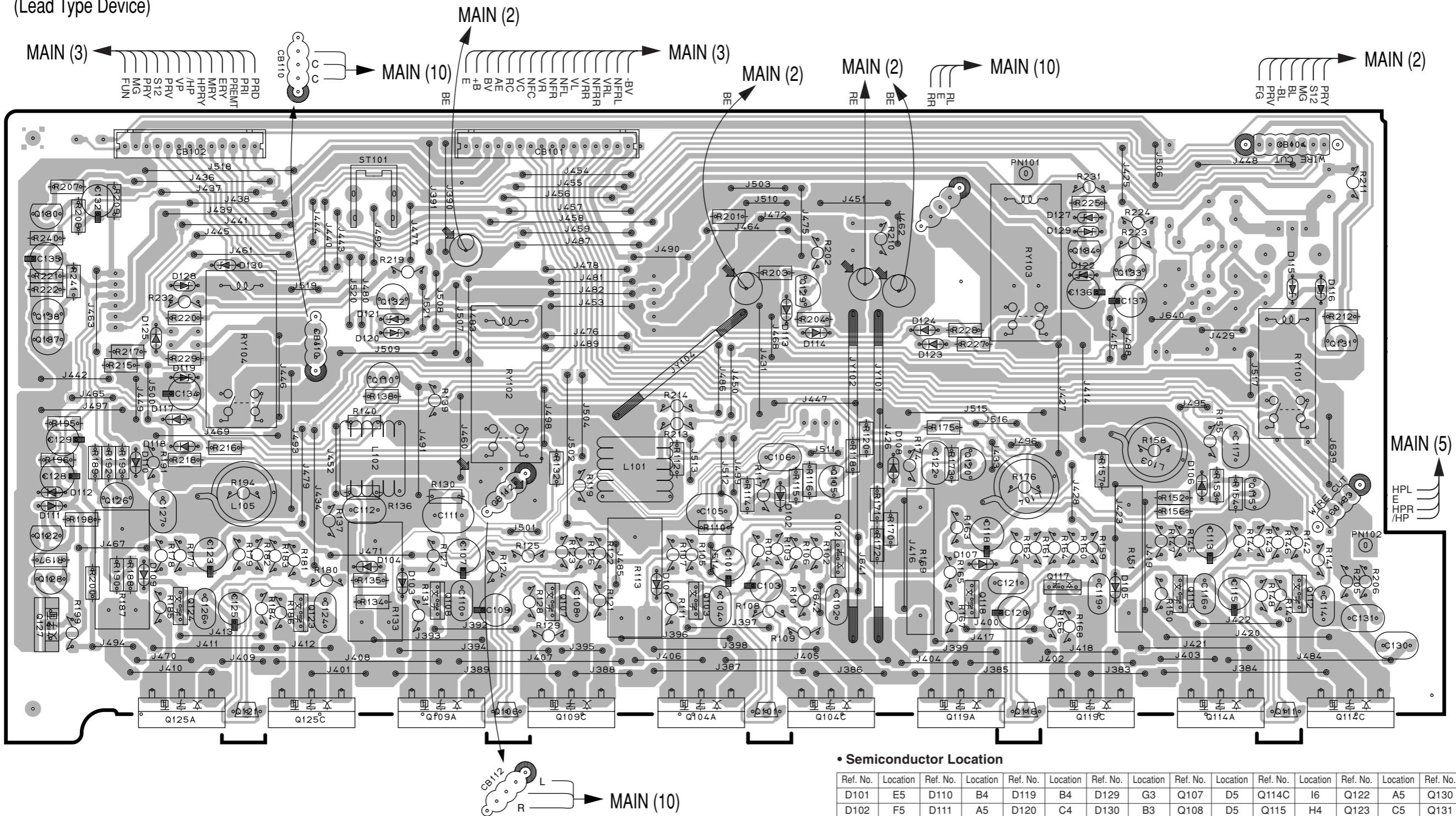

• Semiconductor Location

Ref. No.	Location	Ref. No.	Location	Ref. No.	Location	Ref. No.	Location	Ref. No.	Location	Ref. No.	Location	Ref. No.	Location	Ref. No.	Location
D101	E5	D110	B4	D119	B4	D129	G3	Q107	D5	Q114C	I6	Q122	A5	Q130	A3
D102	F5	D111	A5	D120	C4	D130	B3	Q108	D5	Q115	H4	Q123	C5	Q131	I4
D103	C5	D112	A4	D121	C3	Q101	F6	Q109A	D6	Q116	G6	Q124	B5	Q132	C3
D104	C5	D113	F3	D122	G3	Q102	F5	Q109C	D6	Q117	G5	Q125A	B6	Q133	H3
D105	H5	D114	F4	D123	G4	Q103	E5	Q110	C4	Q118	G5	Q125C	C6	Q134	G3
D106	H4	D115	I3	D124	F4	Q104A	E6	Q111	I6	Q119A	G6	Q126	B5	Q137	A4
D107	G5	D116	I3	D125	B4	Q104C	F6	Q112	I5	Q119C	G6	Q127	A5	Q138	A3
D108	F4	D117	B4	D127	G3	Q105	F4	Q113	H5	Q120	G4	Q128	A5		
D109	B5	D118	B4	D128	B3	Q106	D6	Q114A	H6	Q121	B6	Q129	F3		

1 ■ PRINTED CIRCUIT BOARD (Foil side)

MAIN (2) P. C. B. (Lead Type Device)

Circuit No.	
D253	O
J381, 382	X
Q251	O
R252, 253	O
SW381	O

X: NOT USED
O: USED / APPLICABLE

Circuit No.	
D253	O
J381, 382	X
Q251	O
R252, 253	O
SW381	O

X: NOT USED
O: USED / APPLICABLE

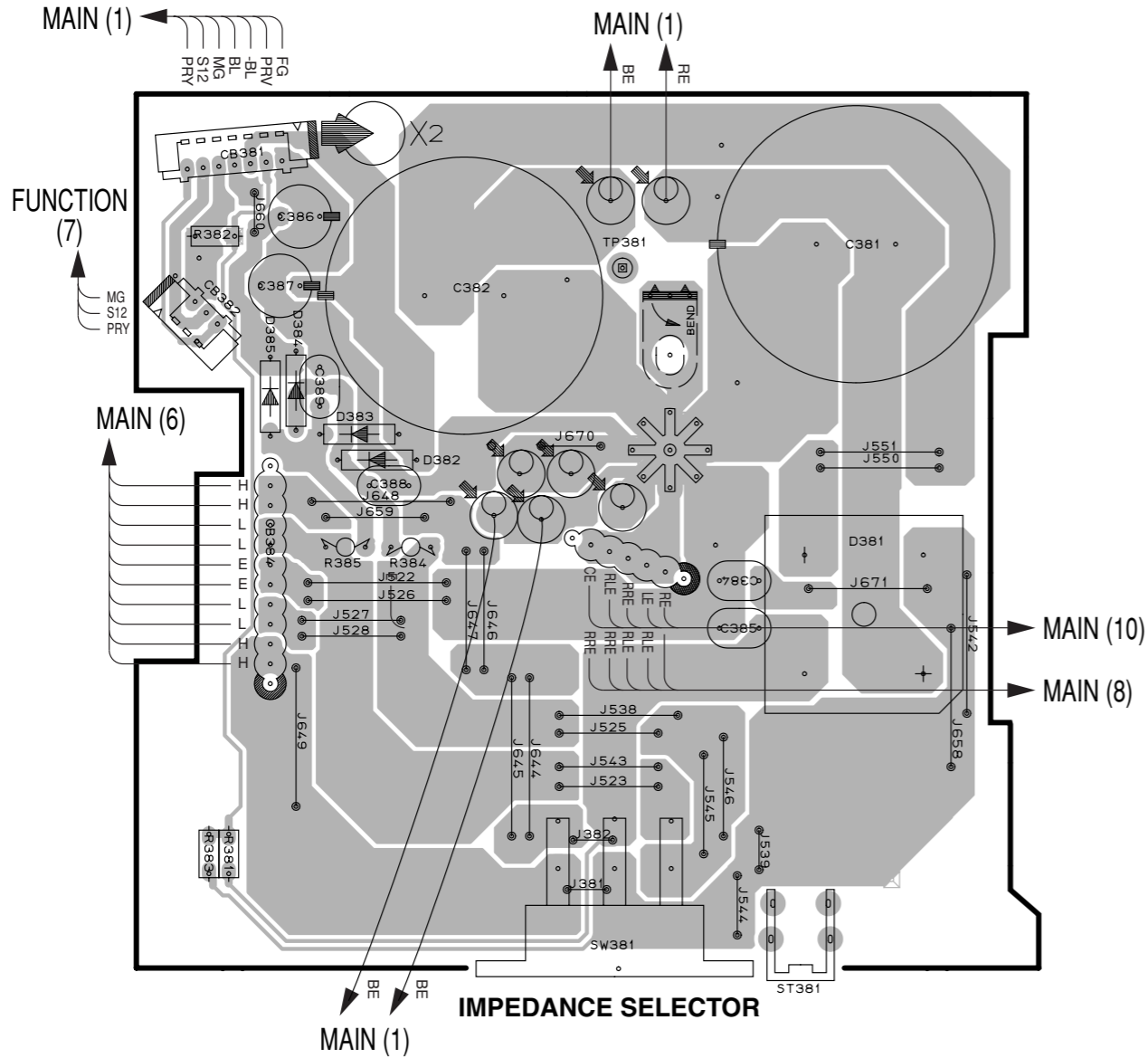

MAIN (3) P. C. B. (Lead Type Device)

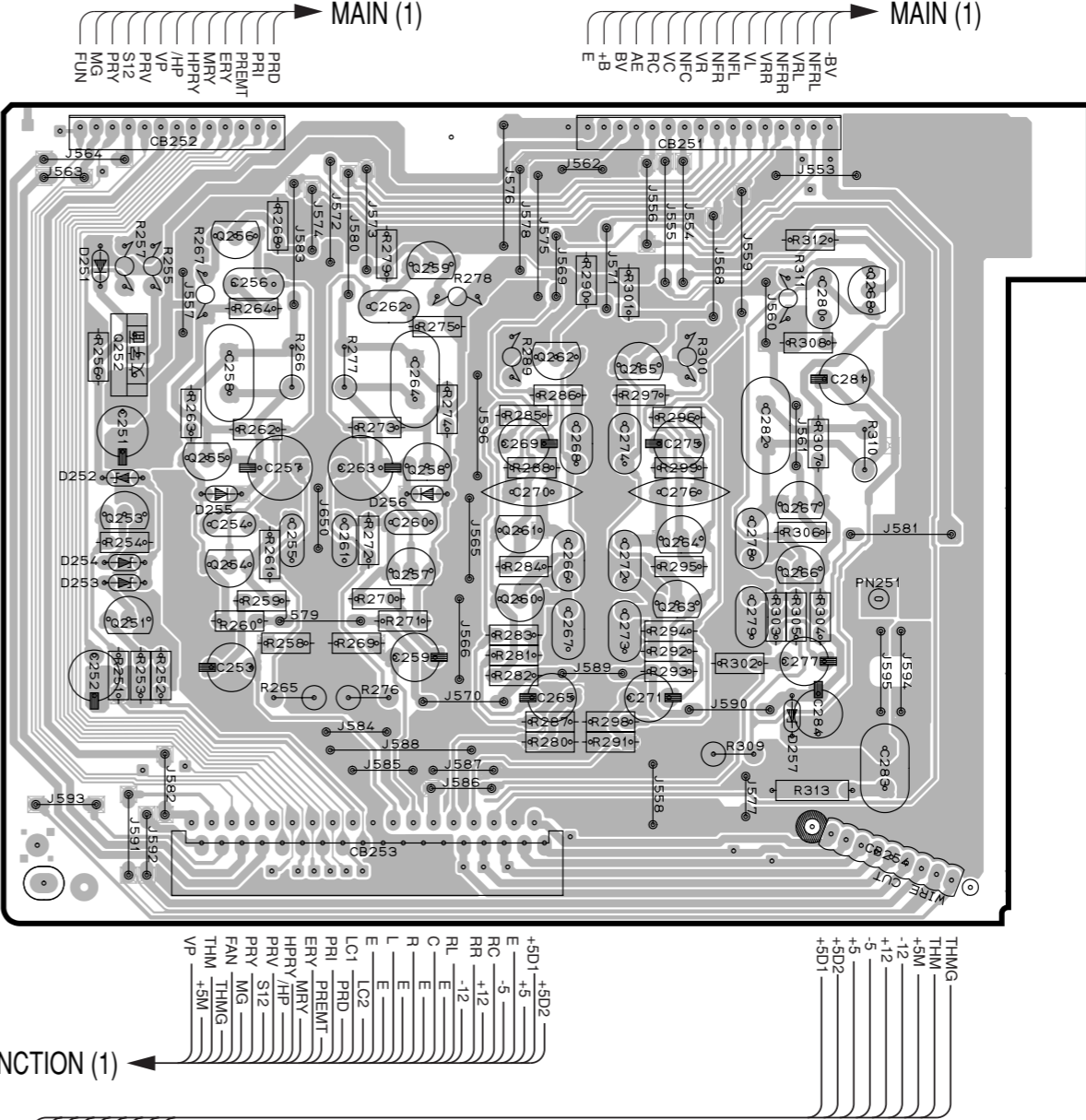

MAIN (4) P. C. B. (Lead Type Device)

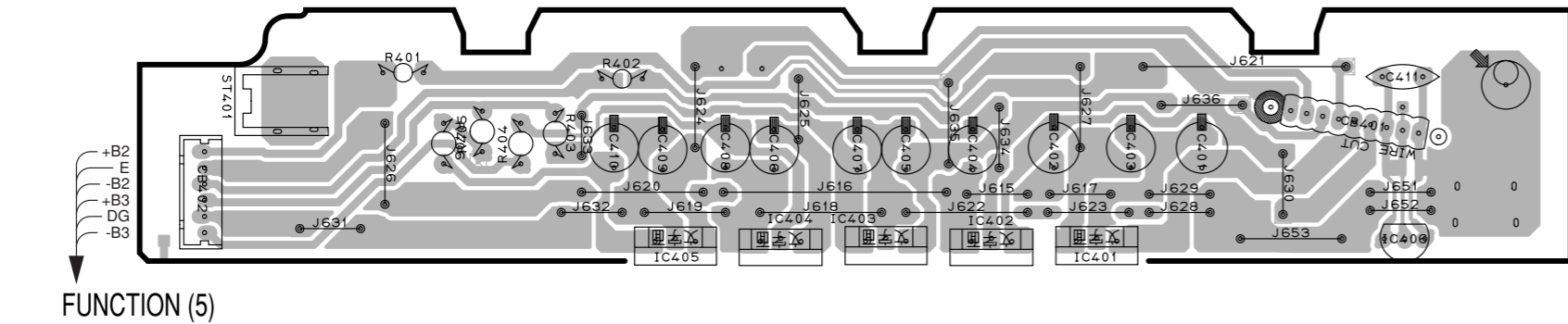

• Semiconductor Location

Ref. No.	Location	Ref. No.	Location	Ref. No.	Location	Ref. No.	Location
D251	F3	D383	B3	Q251	F4	Q260	G4
D252	F4	D384	B3	Q252	F3	Q261	G4
D253	F4	D385	B3	Q253	F4	Q262	G3
D254	F4	IC401	E7	Q254	F4	Q263	H4
D255	F4	IC402	D7	Q255	F3	Q264	H4
D256	G4	IC403	D7	Q256	F3	Q265	G3
D257	H4	IC404	C7	Q257	G4	Q266	H4
D381	D4	IC405	C7	Q258	G3	Q267	H4
D382	B3	IC406	F7	Q259	G3	Q268	H3

■ PRINTED CIRCUIT BOARD (Foil side)

MAIN (5) P. C. B.

(Lead Type Device)

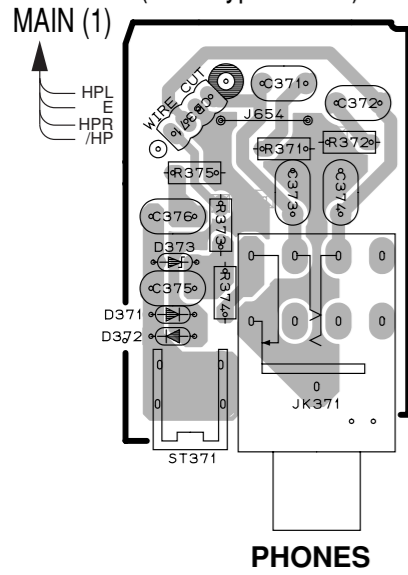

MAIN (6) P. C. B.

(Lead Type Device)

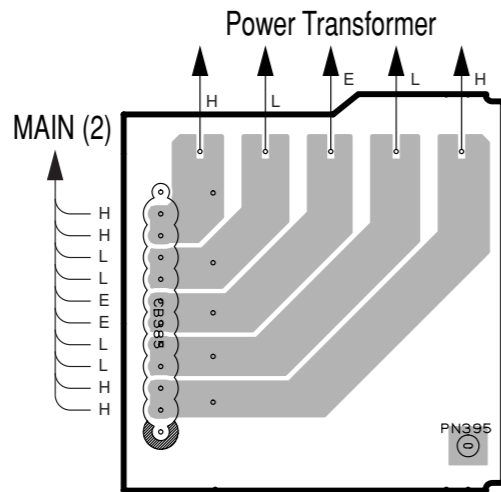

Circuit No.	
C341-344, 351, 353, 354, 371-374, 376	X
R339, 340, 351, 353, 354, 371, 372, 375	X

X: NOT USED
O: USED / APPLICABLE

Circuit No.	
C371-374, 376, 390-392, 395, 399, 421, 422	X
R371, 372, 375, 391-395	X

X: NOT USED
O: USED / APPLICABLE

• Semiconductor Location

Ref. No.	Location
D371	A3
D372	A3
D373	A2

MAIN (10) P. C. B.

(Lead Type Device)

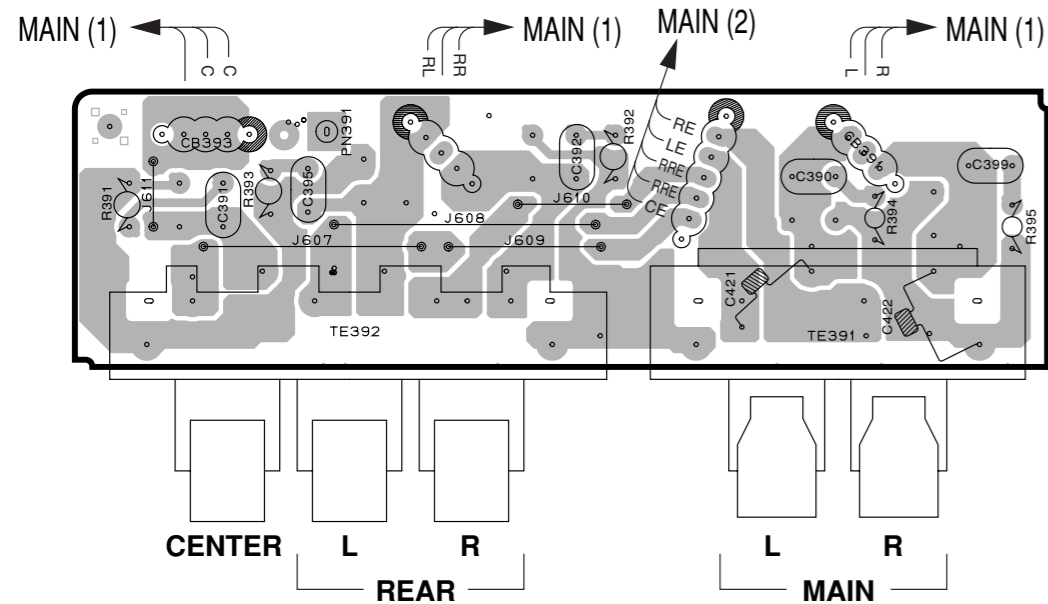

C421 and 422 are installed on the solder surface for the C version, while they are installed on the part surface for the D version.

PIN CONNECTION DIAGRAM

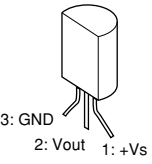
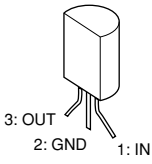
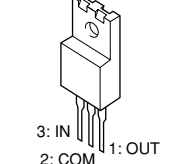
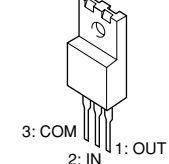
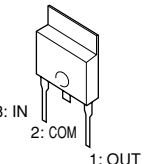
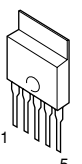
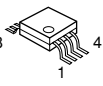
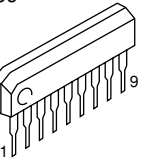
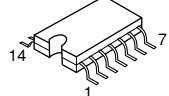
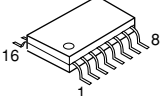
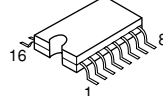
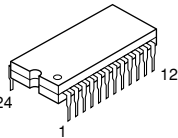
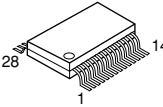
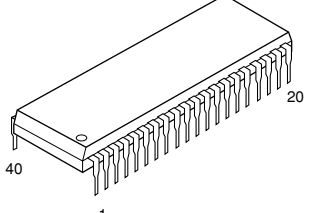
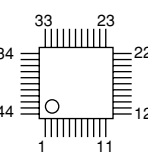
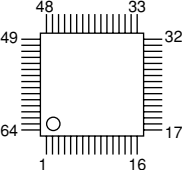
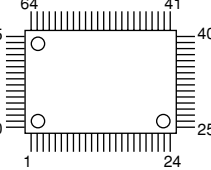
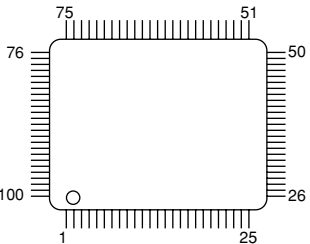
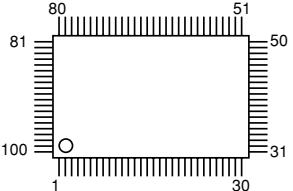
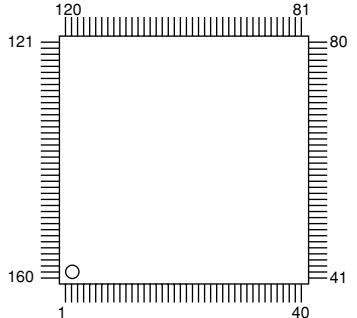

• ICs

<p>LM61CIZ</p>  <p>3: GND 2: Vout 1: +Vs</p>	<p>NJM78L05A-T3</p>  <p>3: OUT 2: GND 1: IN</p>	<p>NJM7805FA NJM7812FA</p>  <p>3: IN 2: COM 1: OUT</p>	<p>NJM79M05FA NJM79M12FA</p>  <p>3: COM 2: IN 1: OUT</p>	<p>μPC29M33T-E1</p>  <p>3: IN 2: COM 1: OUT</p>	<p>PQ025EZ5MZP</p>  <p>1 5</p>
<p>NJM2904M μPC4570G2</p>  <p>8 4 1</p>	<p>LA7956</p>  <p>9 1</p>	<p>TC74HCT00AF TC74HCT08AF TC74HCU04AF</p>  <p>14 7 1</p>	<p>LA7104M</p>  <p>16 8 1</p>	<p>MM74HC4053SJX</p>  <p>16 8 1</p>	<p>LC72722</p>  <p>24 12 1</p>
<p>CY62256LL</p>  <p>28 14 1</p>	<p>MSM514260C-60JS</p>  <p>40 20 1</p>	<p>AK4527BVQ</p>  <p>33 23 22 12 34 44 1 11</p>	<p>LC75712E</p>  <p>48 33 32 17 49 64 1 16</p>	<p>BD3811K1</p>  <p>64 41 40 25 65 80 1 24</p>	
<p>XC9572XL-10TQ100C</p>  <p>75 51 50 26 76 100 1 25</p>	<p>M30624FGA</p>  <p>80 51 50 31 81 100 1 30</p>	<p>YSS938-F</p>  <p>120 81 80 41 121 160 1 40</p>			

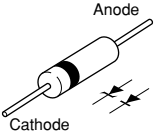
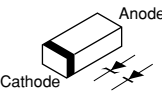
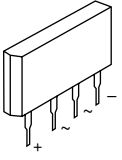
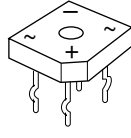
• Diodes

<p>1N4002S 1SS133 1SS176 1SS270A 1T2</p>	<p>MTZJ4.7C MTZJ6.8B MTZJ9.1B MTZJ10.0C MTZJ12.0C MTZJ30.0A</p>		<p>1SS355 MA8075-H RB501V-40 UDZ5.1B UDZ6.2B UDZ7.5B UDZ13B UDZS5.6B UDZS6.8B</p>	
<p>S1VB20</p> 	<p>S5VB20</p> 			

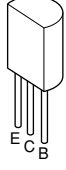
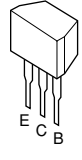
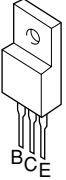
• Transistors

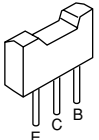
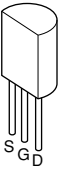
<p>2SA893A 2SA1015 2SB949 2SC1815 2SC1890A</p> 	<p>2SC1740S 2SD1915F 2SD1991A</p> 	<p>2SB1565 2SD2396</p> 	<p>2SA1695 2SC4468</p> 
<p>2SA1037K 2SC2412K 2SC3326 DTA144EK</p> 	<p>2SA1770 2SC4614</p> 	<p>2SK246</p> 	

SCHEMATIC DIAGRAM (FUNCTION 1/2)

- ★ All voltages are measured with a 10MΩ/V DC electric volt meter.
- ★ Components having special characteristics are marked with a star and must be replaced with parts having specifications equal to those originally installed.
- ★ Schematic diagram is subject to change without notice.

- 電圧は、内部抵抗10MΩの電圧計で測定したものです。
- *印のある部品は、安全性確保部品を示しています。部品の交換が必要な場合、パーツリストに記載されている部品を使用してください。
- 本回路図は標準回路図です。改良のため予告なく変更することがございます。

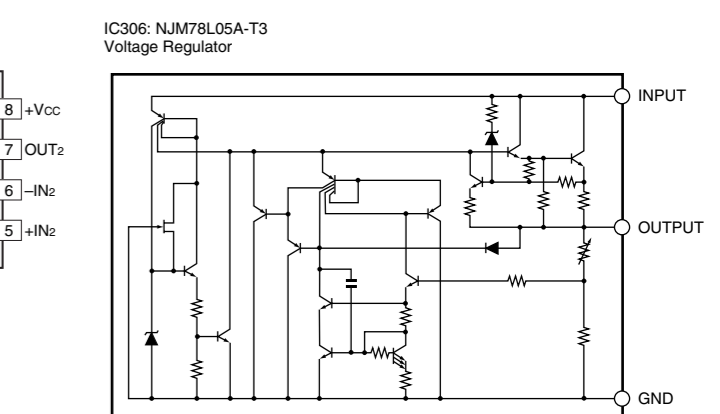
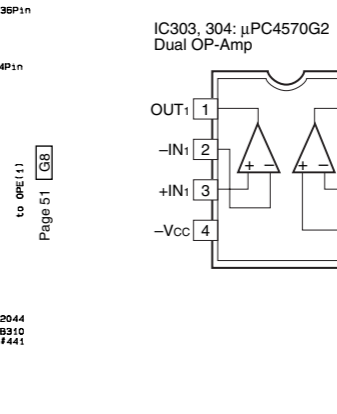
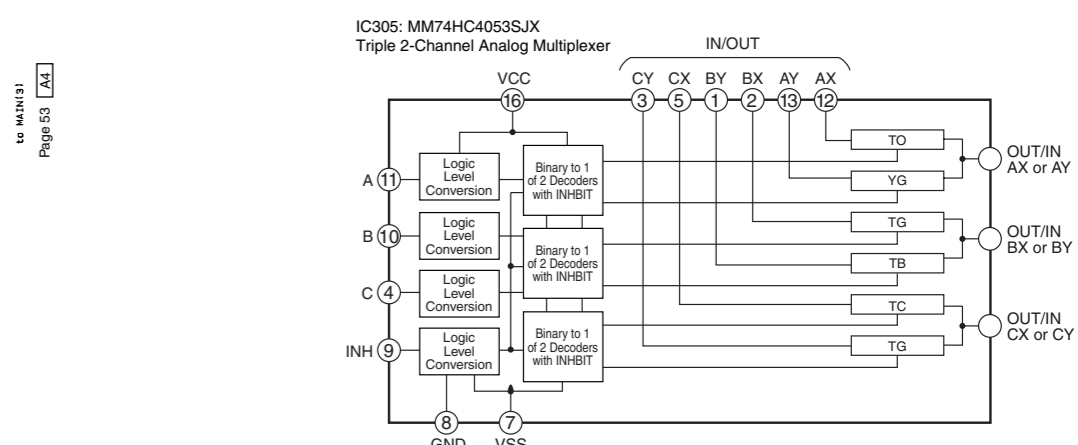
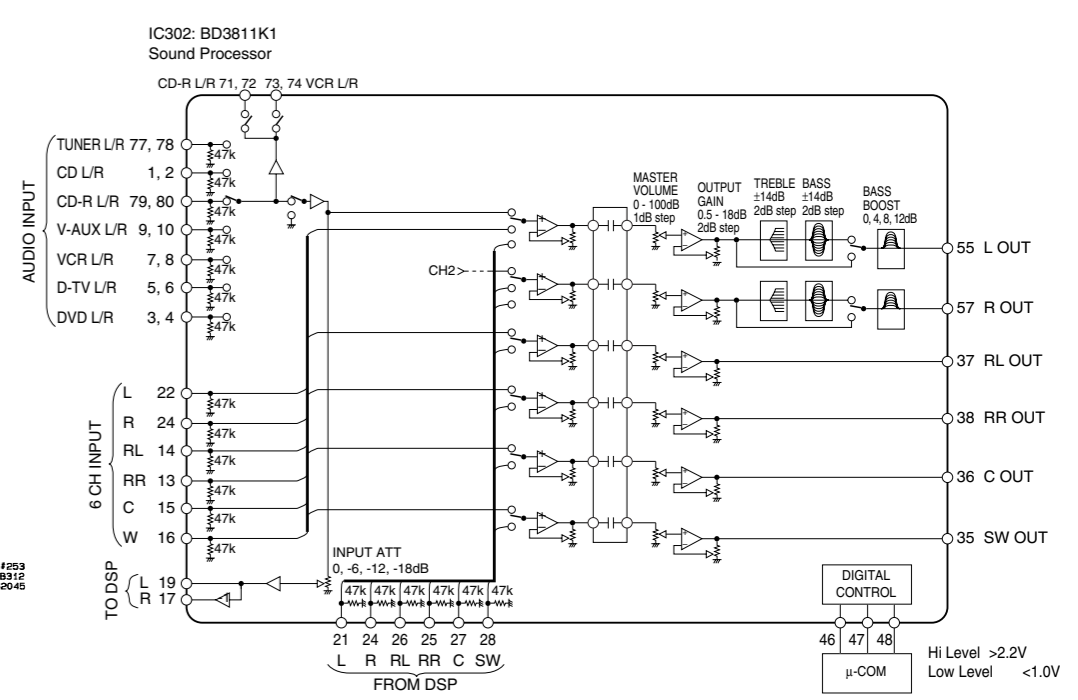
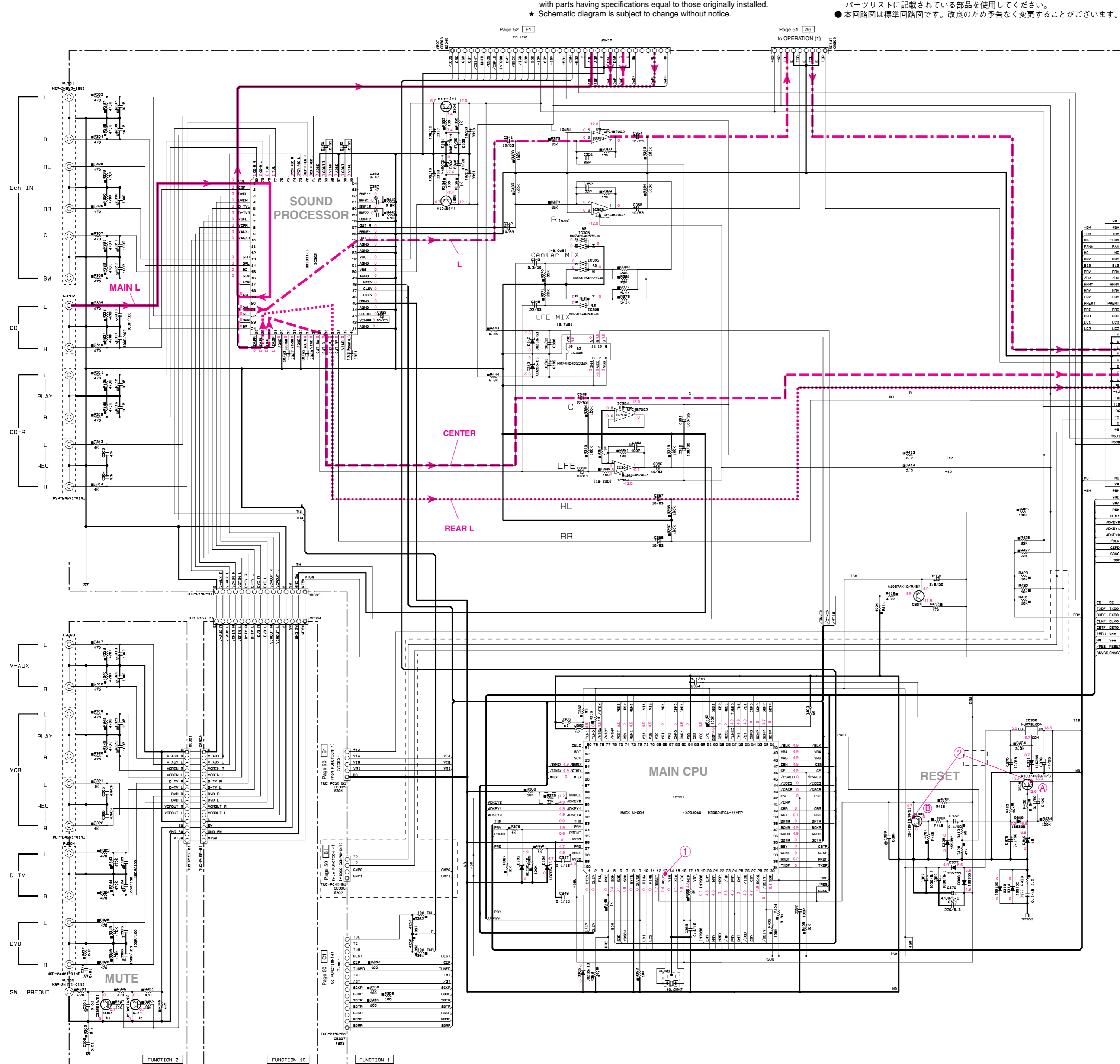

CAPACITOR		RESISTOR	
REMARKS	PARTS NAME	REMARKS	PARTS NAME
NO MARK	ELECTROLYTIC CAPACITOR	NO MARK	CARBON FILM RESISTOR (P=5)
NO MARK	TANTALUM CAPACITOR	NO MARK	CARBON FILM RESISTOR (P=10)
NO MARK	CERAMIC CAPACITOR	NO MARK	METAL OXIDE FILM RESISTOR
◎	CERAMIC TUBULAR CAPACITOR	△	METAL FILM RESISTOR
○	POLYESTER FILM CAPACITOR	□	FINE PROOF CARBON FILM RESISTOR
○	POLYSTYRENE FILM CAPACITOR	□	CEMENT MOLDED RESISTOR
○	MICA CAPACITOR	□	SEMI VARIABLE RESISTOR
◎	POLYPROPYLENE FILM CAPACITOR	■	CHIP RESISTOR
●	SEMICONDUCTIVE CERAMIC CAPACITOR		

Interchangeable Parts at Manufacture-Stage		
Mark	Reference Parts Number	Parts Name
81	0301-311	2SC3381A/B1 2SC3391E1
82	J305	○
83	J306	X
84	R302	X
85	R305	100K RD30810
86	R409	0 RD30900
88	D310	UC796-08 VU17200
89	R419	20K RD30722

X: NOT USED
O: USED / APPLICABLE

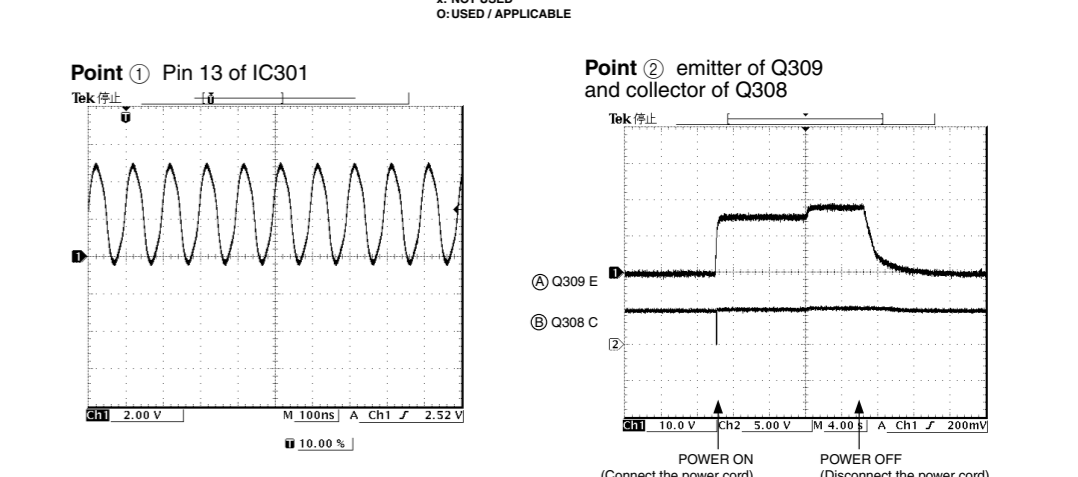

: Not applied to HTR-5635

■ SCHEMATIC DIAGRAM (FUNCTION 2/2)

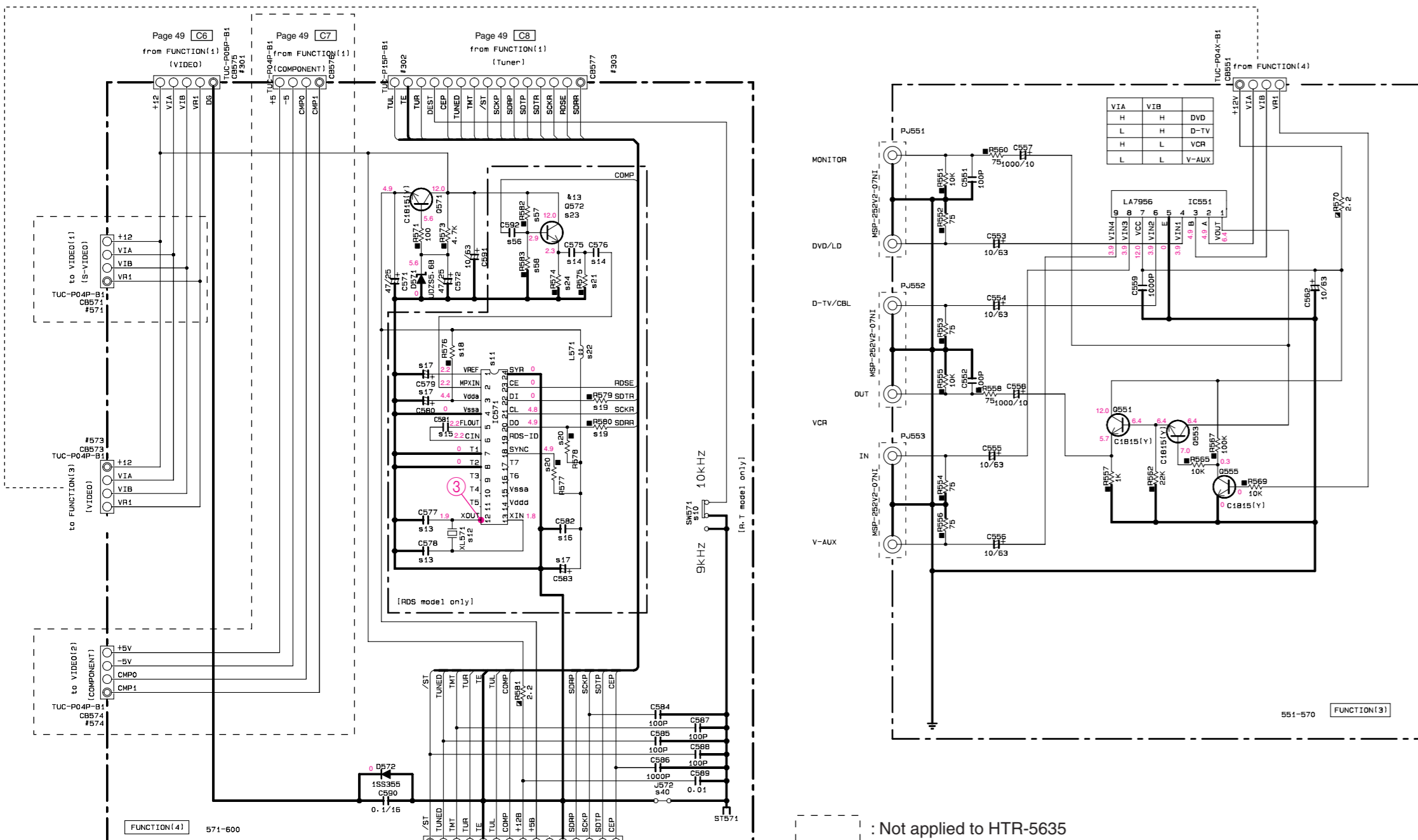

CAPACITOR

REMARKS	PARTS NAME
NO MARK	ELECTROLYTIC CAPACITOR
NO MARK	TANTALUM CAPACITOR
NO MARK	CERAMIC CAPACITOR
◎	CERAMIC TUBULAR CAPACITOR
○	POLYESTER FILM CAPACITOR
⊖	POLYSTYRENE FILM CAPACITOR
⊕	MICA CAPACITOR
⊖	POLYPROPYLENE FILM CAPACITOR
⊕	SEMICONDUCTIVE CERAMIC CAPACITOR

RESISTOR

REMARKS	PARTS NAME
NO MARK	CARBON FILM RESISTOR (P=5)
□	CARBON FILM RESISTOR (P=10)
△	METAL OXIDE FILM RESISTOR
▲	METAL FILM RESISTOR
⊖	METAL PLATE RESISTOR
⊕	FIRE PROOF CARBON FILM RESISTOR
⊖	CEMENT MOLDED RESISTOR
⊕	SEMI VARIABLE RESISTOR
■	CHIP RESISTOR

Interchangeable Parts at Manufacture-Stage

Mark	Reference Parts Number	Parts Name
★11		
★12	RV921	SDT-S-112LMR D01201-01M11 ALK9301
★13	0572	RSC174951A/B3 RSC68031E/P1 RSC3311A/Q/R/S1
★14		

IC551: LA7956
Video Switch

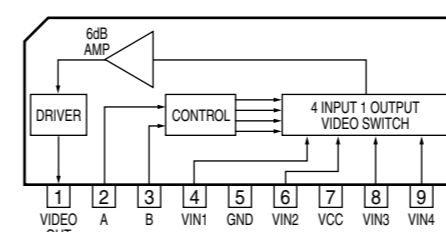

IC571: LC72722
RDS Decoder

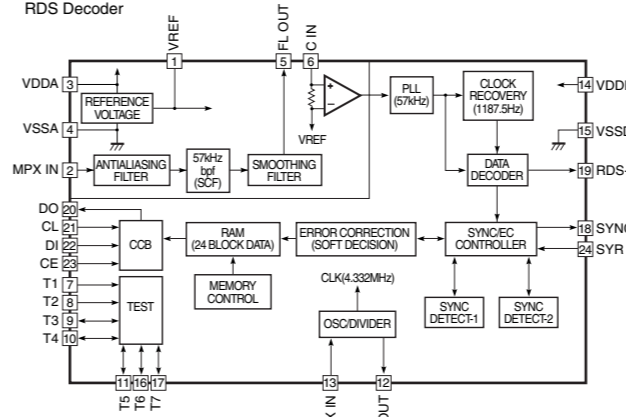

Point ③ Pin 12 of IC571

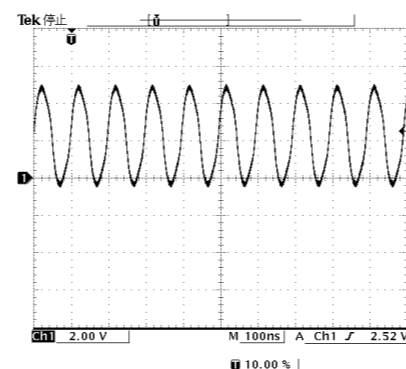

: Not applied to HTR-5635

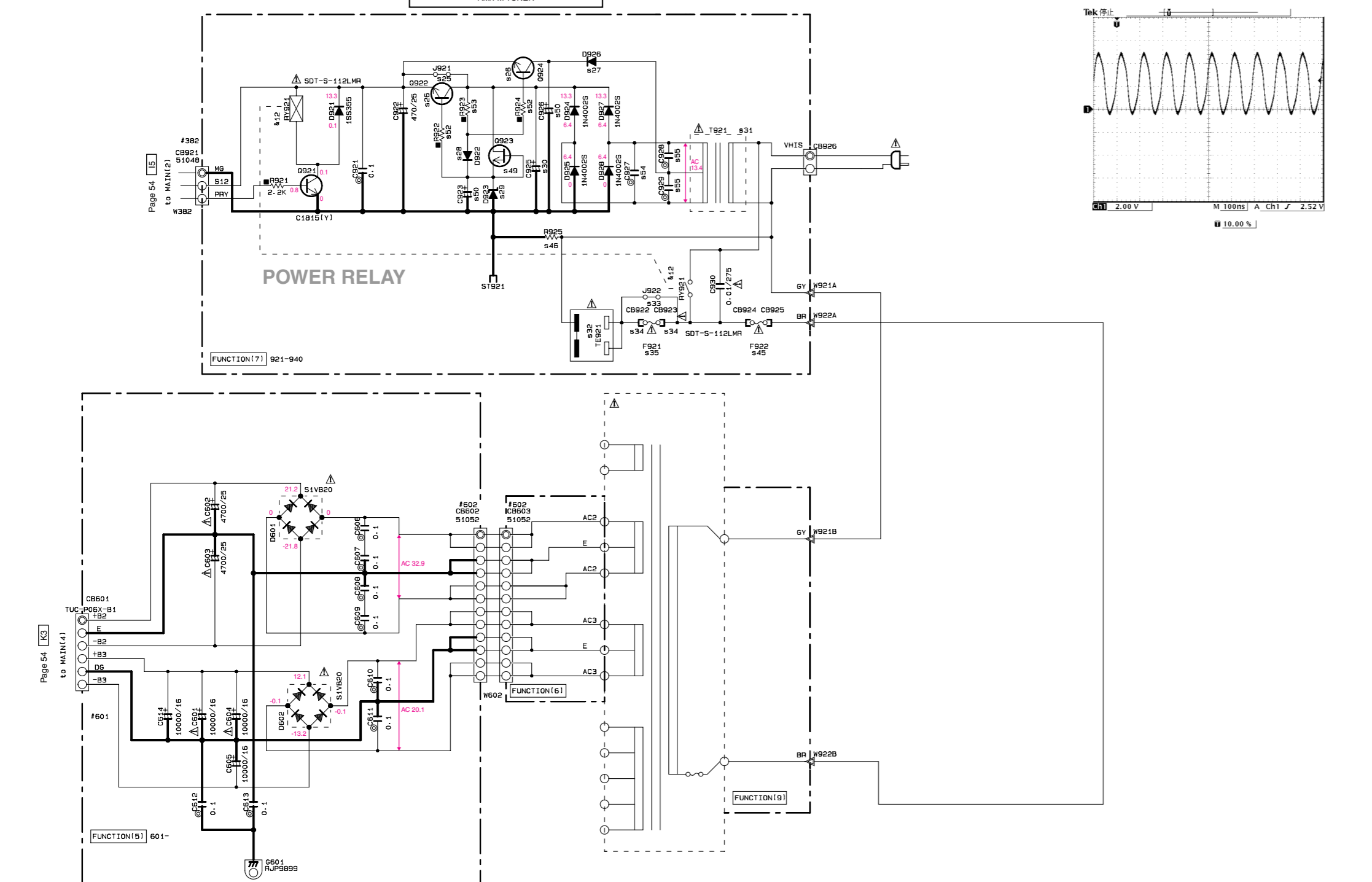

★10	SW571	X
★11	IC571	X
★12	XL571	X
★13	CB77-578	X
★14	CB75-576	X
★15	CS81	X
★16	CS82	X
★17	CS79-580-583	X
★18	RS76	X
★19	RS79-580	X
★20	RS77-578	X
★21	RS75	X
★22	LS71	X
★23	0572	X
★24	RS74	X
★25	J921	O
★26	0922-924	X
★27	D926	X
★28	D922	X
★29	D923	X
★30	CS85	X
★31	T921	XW606
★32	TE921	VU54319
★33	J922	O
★34	CB922-923	X
★35	F921	X
★36	WB43	X
★37	WB41	X
★38	WB45	X
★39	WB42	X
★40	WB44	X
★41	WB46	X
★42	SW41	X
★43	CB941-942	X
★44	F941	X
★45	F922	7A129V V92929
★46	RS25	1/292-2H V673000
★49	0923	X
★50	CB23-926	X
★52	RS22-924	X
★53	RS23	X
★54	CS27	0.01 UA65410
★55	CS28-929	X
★56	CS92	X
★57	RS82	X
★58	RS83	X
★59	WB47	X

X: NOT USED
O: USED / APPLICABLE

★ All voltages are measured with a 10MΩ/V DC electric volt meter.
★ Components having special characteristics are marked ▲ and must be replaced with parts having specifications equal to those originally installed.
★ Schematic diagram is subject to change without notice.

● 電圧は、内部抵抗10MΩの電圧計で測定したものです。
● ▲印のある部品は、安全性確保部品を示しています。部品の交換が必要な場合、パーツリストに記載されている部品を使用してください。
● 本回路図は標準回路図です。改良のため予告なく変更することがございます。

■ SCHEMATIC DIAGRAM (OPERATION)

CAPACITOR

REMARKS	PARTS NAME	
NO MARK	ELECTROLYTIC CAPACITOR	
⊗	TANTALUM CAPACITOR	⊗
NO MARK	CERAMIC CAPACITOR	
●	CERAMIC TUBULAR CAPACITOR	
◎	POLYESTER FILM CAPACITOR	
○	POLYSTYRENE FILM CAPACITOR	
①	MICA CAPACITOR	
Ⓟ	POLYPROPYLENE FILM CAPACITOR	
Ⓢ	SEMICONDUCTIVE CERAMIC CAPACITOR	
Ⓣ	POLYPHENYLENE SULFIDE FILM CAPACITOR	

RESISTOR

REMARKS	PARTS NAME
NO MARK	CARBON FILM RESISTOR (P=5)
⊠	CARBON FILM RESISTOR (P=10)
△	METAL OXIDE FILM RESISTOR
▲	METAL FILM RESISTOR
⊞	METAL PLATE RESISTOR
⊞	FIRE PROOF CARBON FILM RESISTOR
□	CEMENT MOLDED RESISTOR
⊕	SEMI VARIABLE RESISTOR
■	CHIP RESISTOR

s5	SW711-714	×
s6	R711	×
s7	R712	×
s8	R713	×
s9	R714	×

× NOT USED
○ USED / APPLICABLE

- ★ All voltages are measured with a 10MΩ/V DC electric volt meter.
- ★ Components having special characteristics are marked / and must be replaced with parts having specifications equal to those originally installed.
- ★ Schematic diagram is subject to change without notice.

- 電圧は、内部抵抗10MΩの電圧計で測定したものです。
- /印のある部品は、安全性確保部品を示しています。部品の交換が必要な場合、パーツリストに記載されている部品を使用してください。
- 本回路図は標準回路図です。改良のため予告なく変更することがございます。

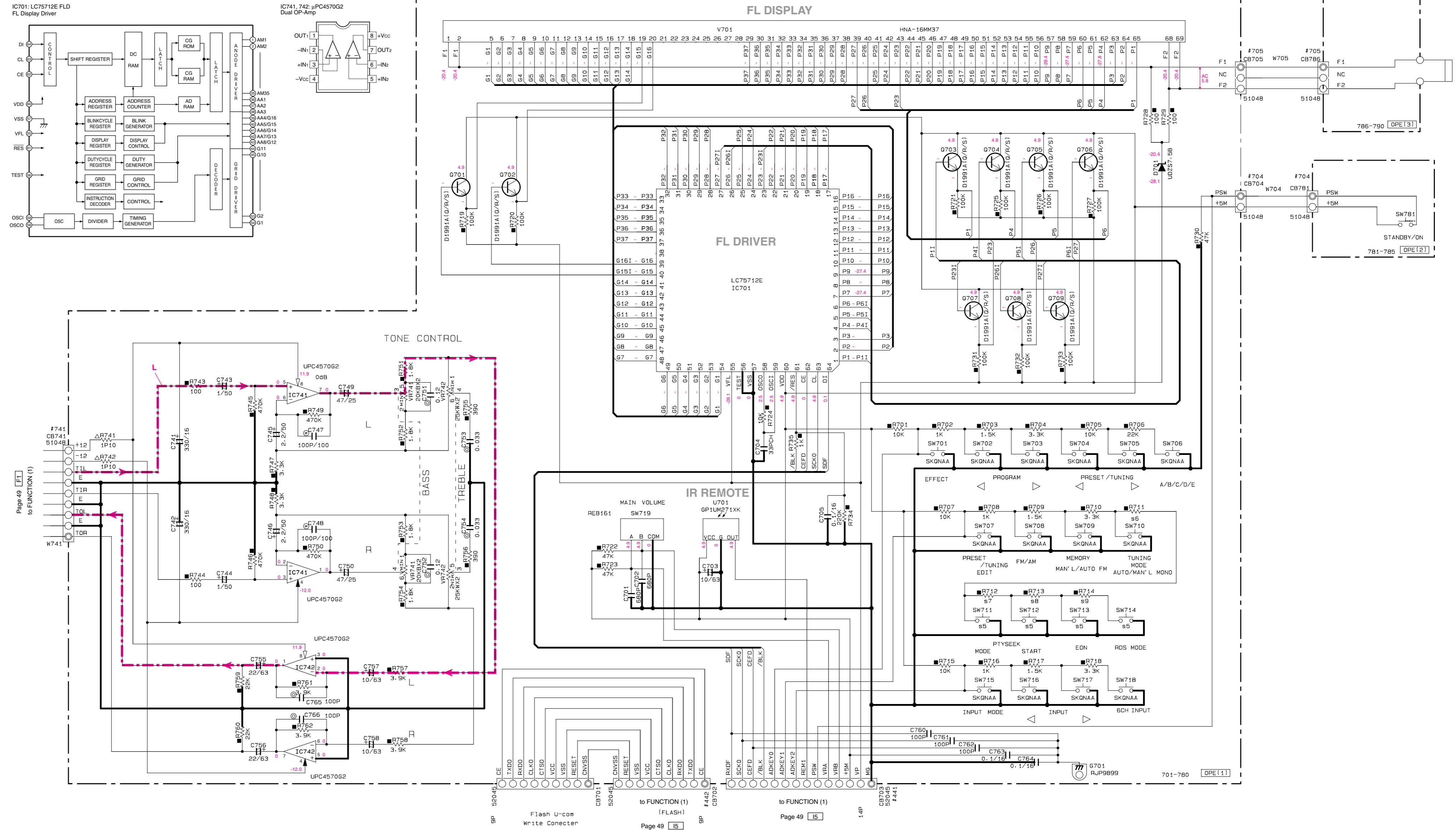

Page 49 [ET] to FUNCTION (1)

Flash U-com Write Connector
Page 49 [IS]

Page 49 [LS]

701-780 [OPE(1)]

SCHEMATIC DIAGRAM (DSP)

Page 49 E1 to FUNCTION (1)

REMARKS	PARTS NAME
NO MARK	CARBON FILM RESISTOR (P=5)
□	CARBON FILM RESISTOR (P=10)
△	METAL OXIDE FILM RESISTOR
◇	METAL PLATE RESISTOR
○	FIRE PROOF CARBON FILM RESISTOR
◎	CEMENT MOLDED RESISTOR
⊙	VARIABLE RESISTOR
⊗	CHIP RESISTOR

REMARKS	PARTS NAME
NO MARK	ELECTROLYTIC CAPACITOR
□	TANTALUM CAPACITOR
○	CERAMIC CAPACITOR
⊙	CERAMIC TUBULAR CAPACITOR
◇	POLYESTER FILM CAPACITOR
○	POLYSTYRENE FILM CAPACITOR
⊙	MICA CAPACITOR
⊕	POLYPROPYLENE FILM CAPACITOR
⊗	SEMICONDUCTIVE CERAMIC CAPACITOR
⊙	POLYPHENYLENE SULFIDE FILM CAPACITOR

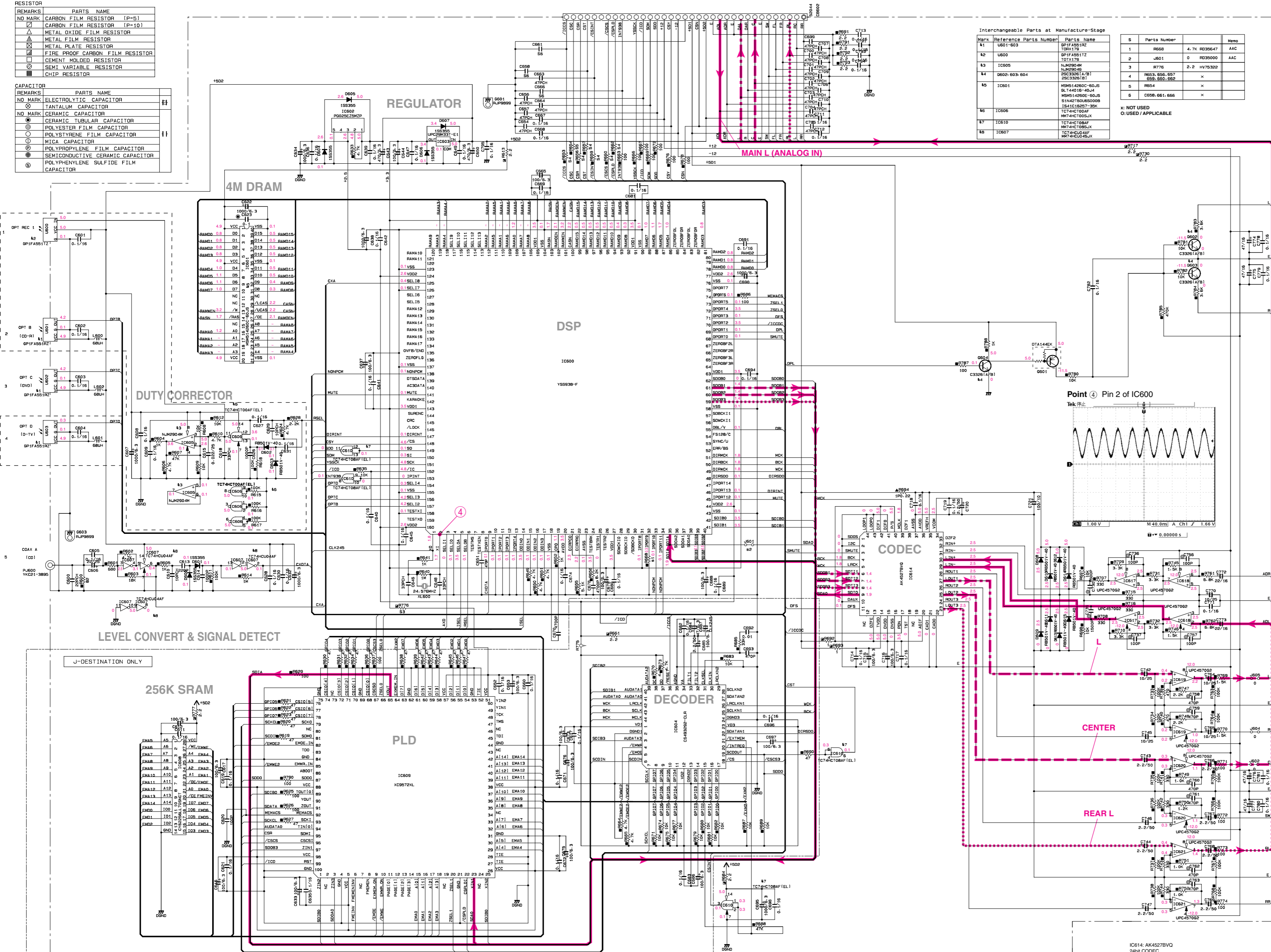

Interchangeable Parts at Manufacture Stage

Mark	Reference Parts Number	Parts Name	S	Parts Number	4.7K RD30647	Mark
A1	U601-603	SP1FA0512 TDPA175	1	R508	4.7K RD30647	AAC
A2	U604	OT1X175	2	J501	2.2 RD30600	AAC
A3	IC605	SP1FA0512 M909046	3	H776	2.2 HV78392	X
A4	9002-603-604	SP3302181 SP3302181	4	R503	659.552.552	X
A5	IC601	MSM514260C-60JS M14018-40JA M9014200E-60JS S1M41801800000 1841C1827-35X	5	R504	X	X
A6	IC606	TC74HC00A M74HC00LX	6	C509	661.656	X
A7	IC610	TC74HC08AF M74HC08LX	7			
A8	IC607	TC74HC04AF M74HC04LX	8			

X: NOT USED
O: USED / APPLICABLE

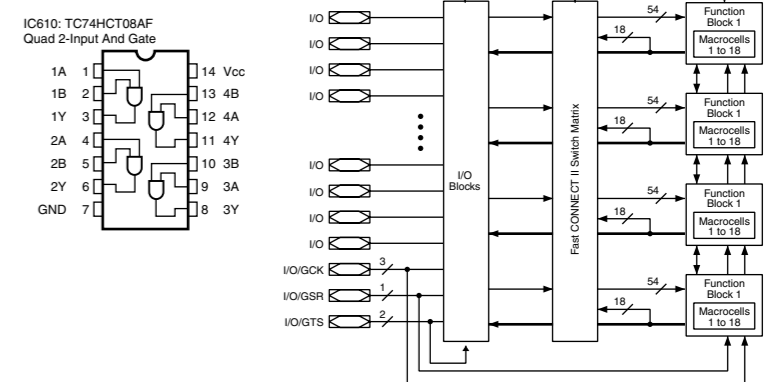
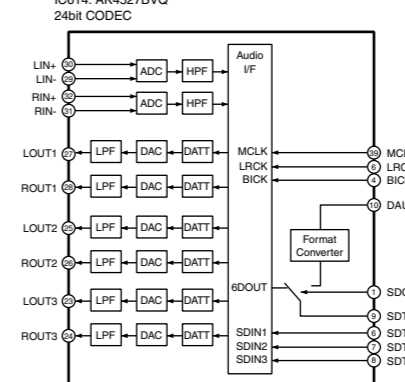
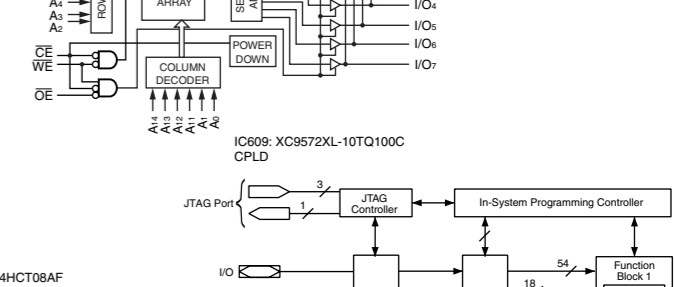
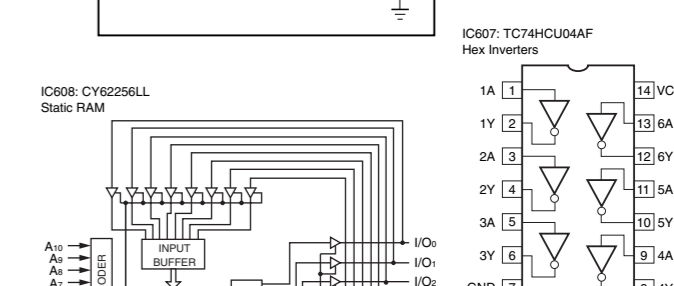
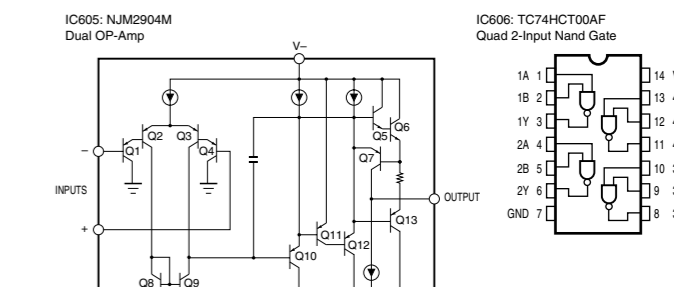
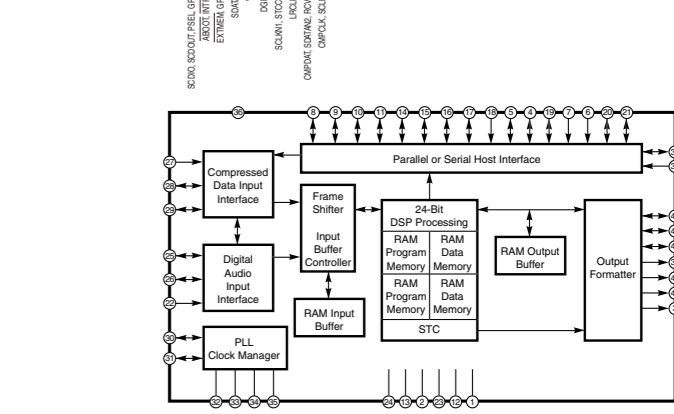
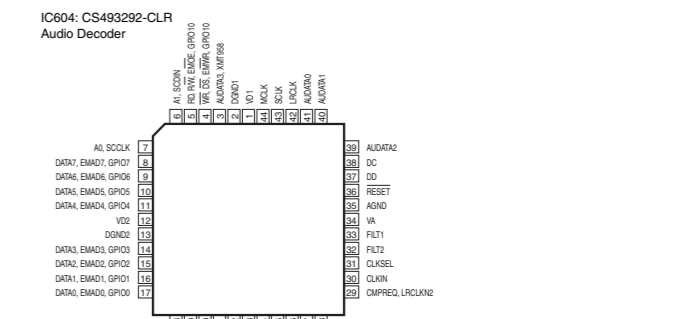
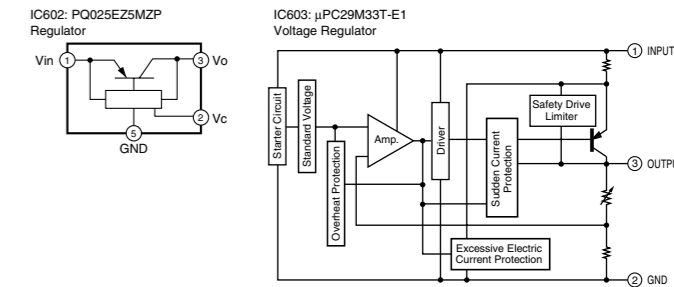
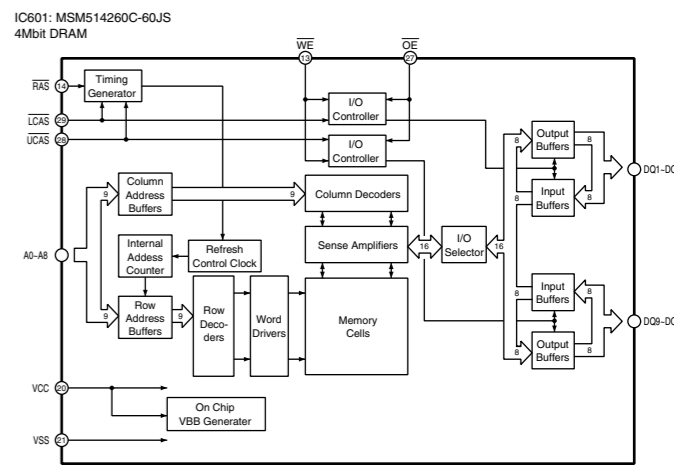
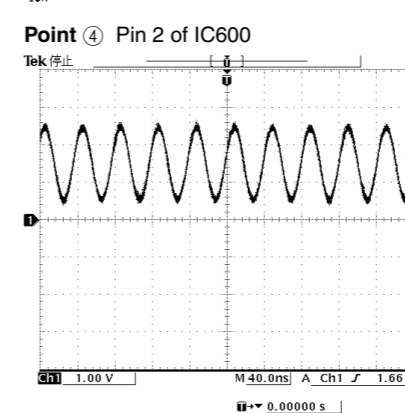

Not applied to HTR-5635

: Not applied to HTR-5635

- ★ All voltages are measured with a 10MΩ/DC electric volt meter.
- ★ Components having special characteristics are marked **▲** and must be replaced with parts having specifications equal to those originally installed.
- ★ Schematic diagram is subject to change without notice.

- 電圧は、内部抵抗10MΩの電圧計で測定したものです。
- ▲印のある部品は、安全性確保部品を示しています。部品の交換が必要な場合、パーツリストに記載されている部品を使用してください。
- 本回路図は標準回路図です。改良のため予告なく変更することがございます。

SCHEMATIC DIAGRAM (MAIN 1/2)

1
2
3
4
5
6
7
8
9

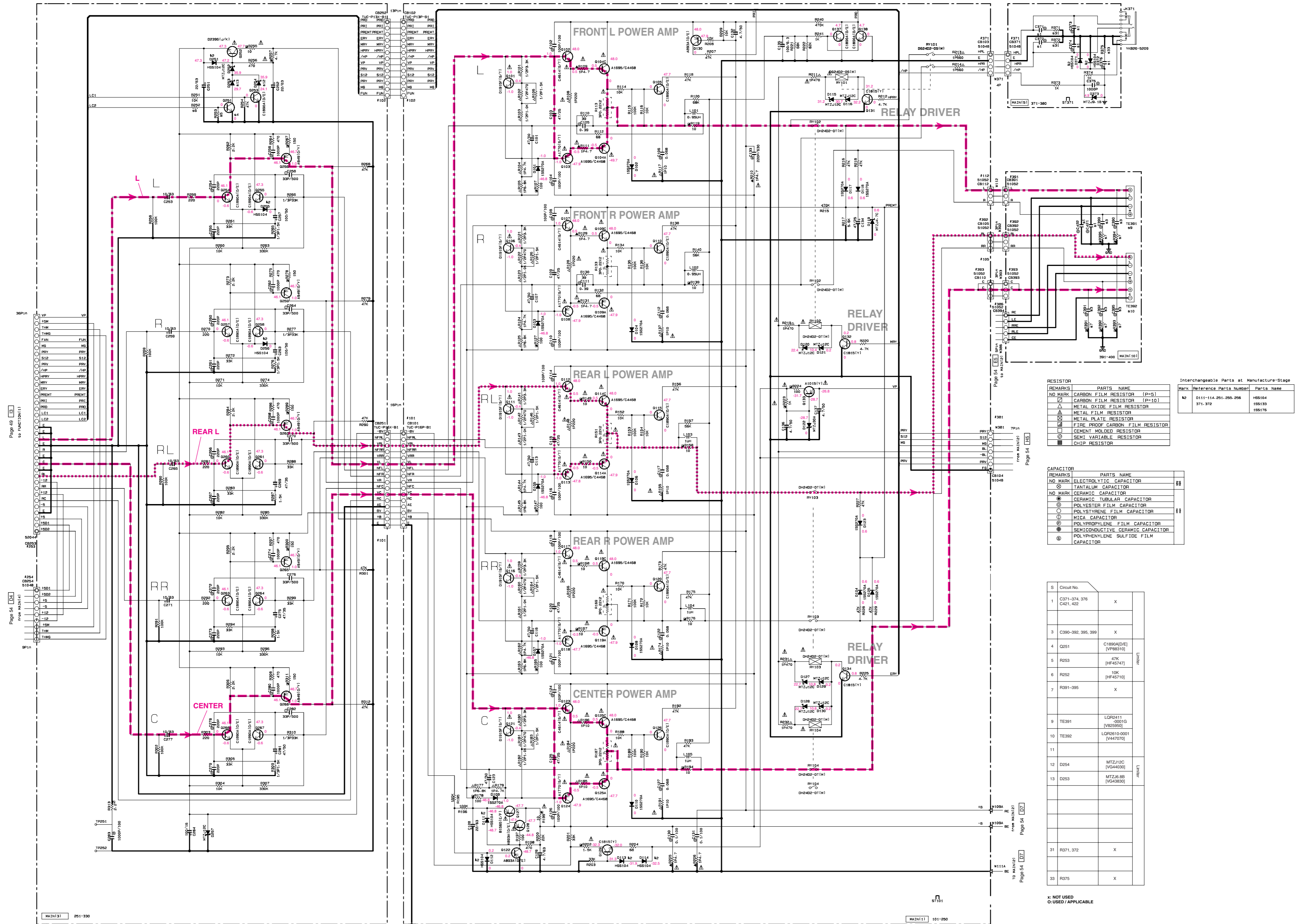

Page 49 [LB] 10 FUNCTION(1)
 Page 54 [LB] 1501
 Page 54 [LB] 1502
 Page 54 [LB] 1503
 Page 54 [LB] 1504
 Page 54 [LB] 1505
 Page 54 [LB] 1506
 Page 54 [LB] 1507
 Page 54 [LB] 1508
 Page 54 [LB] 1509
 Page 54 [LB] 1510
 Page 54 [LB] 1511
 Page 54 [LB] 1512
 Page 54 [LB] 1513
 Page 54 [LB] 1514
 Page 54 [LB] 1515
 Page 54 [LB] 1516
 Page 54 [LB] 1517
 Page 54 [LB] 1518
 Page 54 [LB] 1519
 Page 54 [LB] 1520
 Page 54 [LB] 1521
 Page 54 [LB] 1522
 Page 54 [LB] 1523
 Page 54 [LB] 1524
 Page 54 [LB] 1525
 Page 54 [LB] 1526
 Page 54 [LB] 1527
 Page 54 [LB] 1528
 Page 54 [LB] 1529
 Page 54 [LB] 1530
 Page 54 [LB] 1531
 Page 54 [LB] 1532
 Page 54 [LB] 1533
 Page 54 [LB] 1534
 Page 54 [LB] 1535
 Page 54 [LB] 1536
 Page 54 [LB] 1537
 Page 54 [LB] 1538
 Page 54 [LB] 1539
 Page 54 [LB] 1540
 Page 54 [LB] 1541
 Page 54 [LB] 1542
 Page 54 [LB] 1543
 Page 54 [LB] 1544
 Page 54 [LB] 1545
 Page 54 [LB] 1546
 Page 54 [LB] 1547
 Page 54 [LB] 1548
 Page 54 [LB] 1549
 Page 54 [LB] 1550

Interchangeable Parts at Manufacture-Stage

Mark	Reference Parts Number	Parts Name
!	0111-114-291, 295-296	H85104
!	371-372	185133
!		185176

CAPACITOR

REMARKS	PARTS NAME
NO MARK	ELECTROLYTIC CAPACITOR
NO MARK	TANTALUM CAPACITOR
NO MARK	CERAMIC CAPACITOR
!	CERAMIC TUBULAR CAPACITOR
!	POLYESTER FILM CAPACITOR
!	POLYSTYRENE FILM CAPACITOR
!	MICA CAPACITOR
!	POLYPROPYLENE FILM CAPACITOR
!	SEMICONDUCTIVE CERAMIC CAPACITOR
!	POLYPHENYLENE SULFIDE FILM CAPACITOR

S	Circuit No.	Parts Name	Remarks
1	C371-374, 376 C421, 422	X	
3	C390-392, 395, 399	X	
4	Q251	C180A1DE [V986310]	
5	R253	47K [HF45747]	
6	R252	10K [HF45710]	
7	R391-395	X	
9	TE391	LQR2411 3001G [V829550]	
10	TE392	LQR2610-0001 [V447070]	
11			
12	D254	MT2J12C [V644030]	LINE
13	D253	MT2J6.8B [V643830]	LINE
31	R371, 372	X	
33	R375	X	

X: NOT USED
 O: USED / APPLICABLE

★ All voltages are measured with a 10MΩ/V DC electric volt meter.
 ★ Components having special characteristics are marked '!' and must be replaced with parts having specifications equal to those originally installed.
 ★ Schematic diagram is subject to change without notice.

● 電圧は、内部抵抗10MΩの電圧計で測定したものです。
 ● '!'印のある部品は、安全性確保部品を示しています。部品の交換が必要な場合、パーツリストに記載されている部品を使用してください。
 ● 本回路図は標準回路図です。改良のため予告なく変更することがございます。

SCHEMATIC DIAGRAM (MAIN 2/2)

RESISTOR

REMARKS	PARTS NAME
NO MARK	CARBON FILM RESISTOR (P=5)
☐	CARBON FILM RESISTOR (P=10)
△	METAL OXIDE FILM RESISTOR
▲	METAL FILM RESISTOR
⊠	METAL PLATE RESISTOR
▨	FIRE PROOF CARBON FILM RESISTOR
□	CEMENT MOLDED RESISTOR
⊙	SEMI VARIABLE RESISTOR
■	CHIP RESISTOR

CAPACITOR

REMARKS	PARTS NAME
NO MARK	ELECTROLYTIC CAPACITOR
⊗	TANTALUM CAPACITOR
NO MARK	CERAMIC CAPACITOR
●	CERAMIC TUBULAR CAPACITOR
◎	POLYESTER FILM CAPACITOR
○	POLYSTYRENE FILM CAPACITOR
①	MICA CAPACITOR
Ⓟ	POLYPROPYLENE FILM CAPACITOR
⊙	SEMICONDUCTIVE CERAMIC CAPACITOR

s	Circuit No.	
21	J381.382	X
22	SW381	SL13B-022AMCS [V410420]

x: NOT USED
o: USED / APPLICABLE

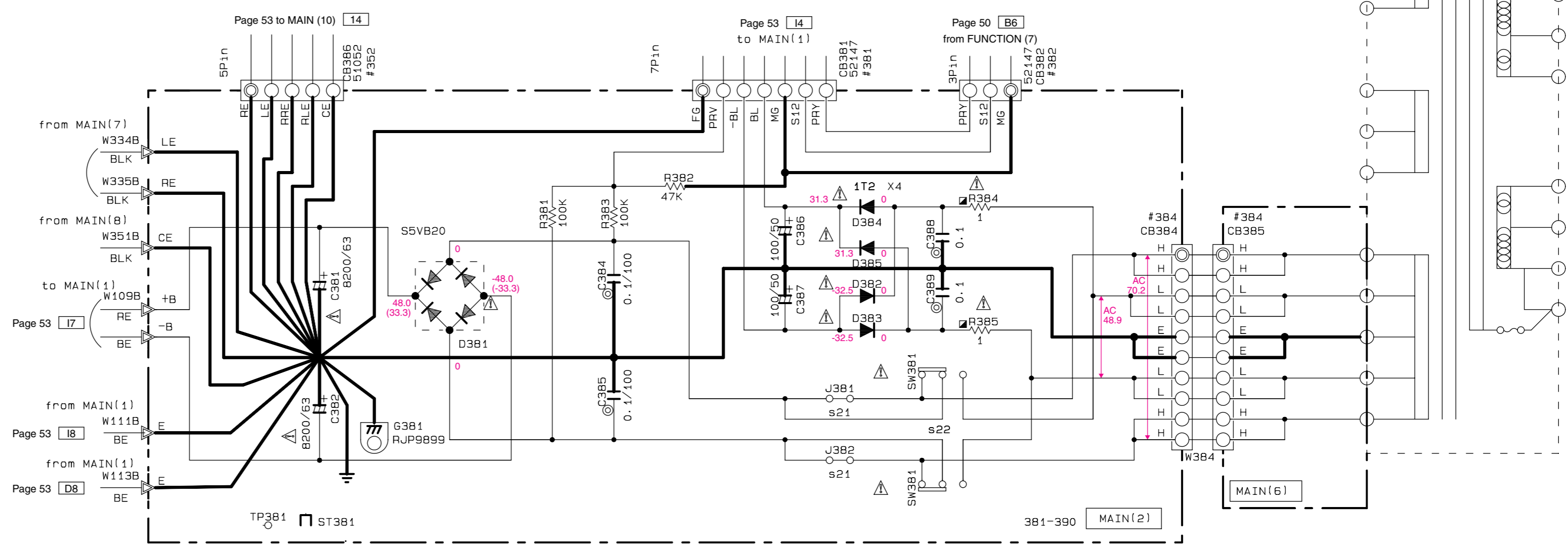
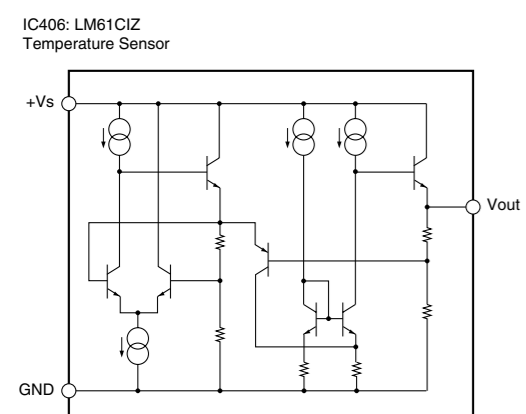
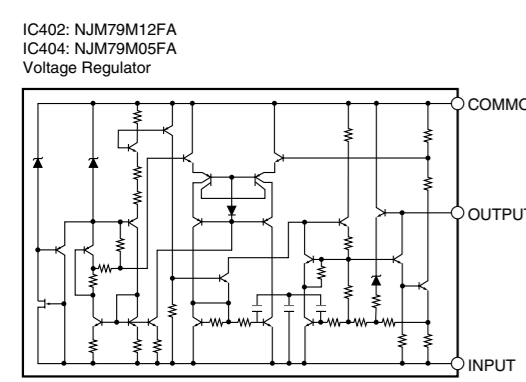
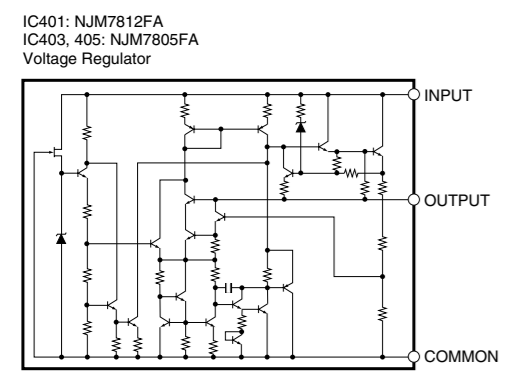
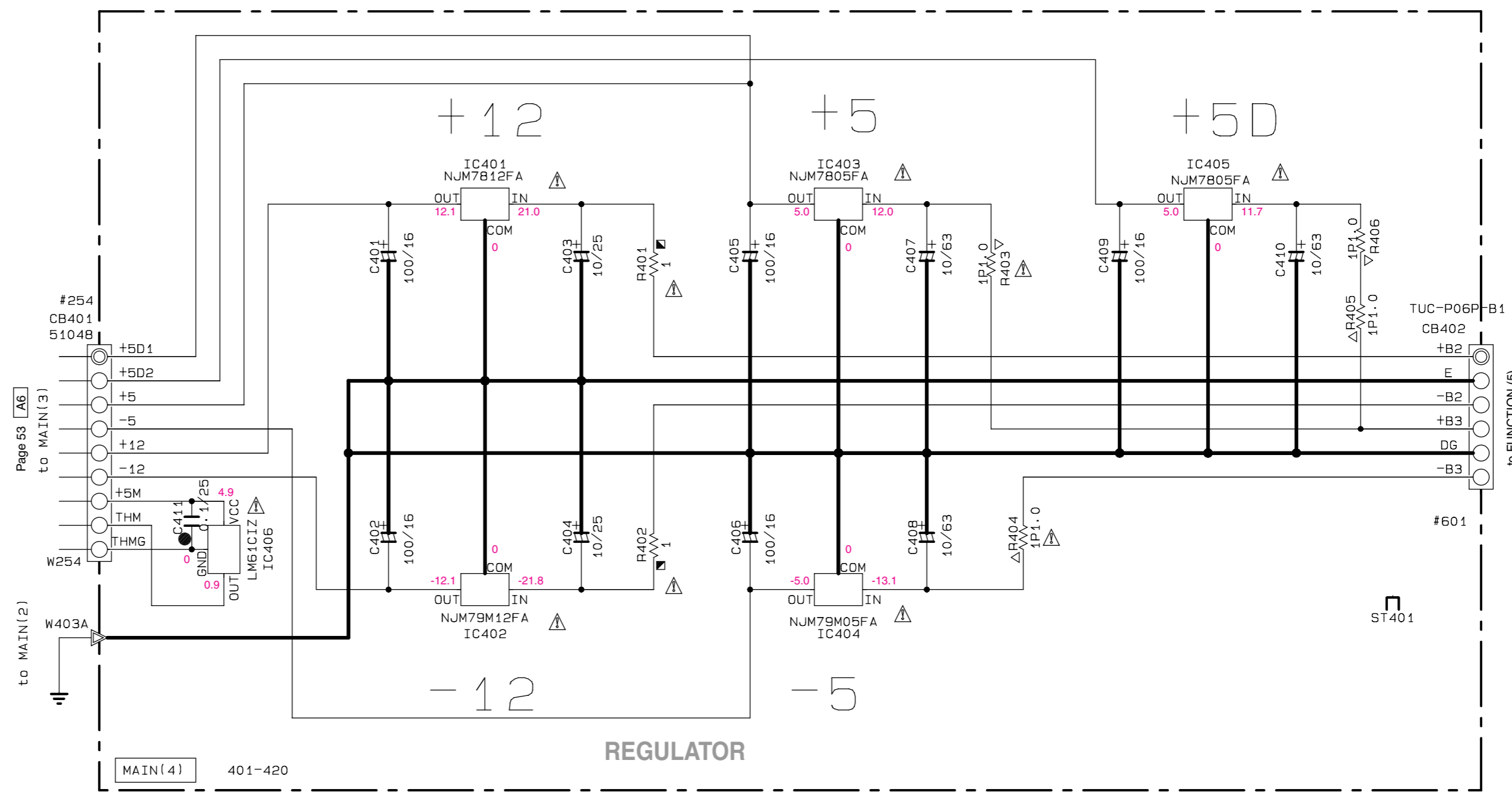

★ All voltages are measured with a 10MΩ/V DC electric volt meter.
★ Components having special characteristics are marked with a triangle and must be replaced with parts having specifications equal to those originally installed.
★ Schematic diagram is subject to change without notice.

● 電圧は、内部抵抗10MΩの電圧計で測定したものです。
● △印のある部品は、安全性確保部品を示しています。部品の交換が必要な場合、パーツリストに記載されている部品を使用してください。
● 本回路図は標準回路図です。改良のため予告なく変更することがございます。

PARTS LIST

■ ELECTRICAL PARTS

■ WARNING

- Components having special characteristics are marked  and must be replaced with parts having specifications equal to those originally installed.

ABBREVIATIONS IN THIS LIST ARE AS FOLLOWS:

C.A.EL.CHP	: CHIP ALUMI.ELECTROLYTIC CAP	L.EMIT	: LIGHT EMITTING MODULE
C.CE	: CERAMIC CAP	LED.DSPLY	: LED DISPLAY
C.CE.ARRAY	: CERAMIC CAP ARRAY	LED.INFRD	: LED,INFRARED
C.CE.CHP	: CHIP CERAMIC CAP	MODUL.RF	: MODULATOR,RF
C.CE.ML	: MULTILAYER CERAMIC CAP	PHOT.CPL	: PHOTO COUPLER
C.CE.M.CHP	: CHIP MULTILAYER CERAMIC CAP	PHOT.INTR	: PHOTO INTERRUPTER
C.CE.SAFTY	: RECOGNIZED CERAMIC CAP	PHOT.RFLCT	: PHOTO REFLECTOR
C.CE.TUBLR	: CERAMIC TUBULAR CAP	PIN.TEST	: PIN,TEST POINT
C.CE.SMI	: SEMI CONDUCTIVE CERAMIC CAP	PLST.RIVET	: PLASTIC RIVET
C.EL	: ELECTROLYTIC CAP	R.ARRAY	: RESISTOR ARRAY
C.MICA	: MICA CAP	R.CAR.	: CARBON RESISTOR
C.ML.FLM	: MULTILAYER FILM CAP	R.CAR.CHP	: CHIPRESISTOR
C.MP	: METALLIZED PAPER CAP	R.CAR.FP	: FLAME PROOF CARBON RESISTOR
C.MYLAR	: MYLAR FILM CAP	R.FUS	: FUSABLE RESISTOR
C.MYLAR.ML	: MULTILAYER MYLAR FILM CAP	R.MTL.CHP	: CHIP METAL FILM RESISTOR
C.PAPER	: PAPER CAPACITOR	R.MTL.FLM	: METAL FILM RESISTOR
C.PLS	: POLYSTYRENE FILM CAP	R.MTL.OXD	: METAL OXIDE FILM RESISTOR
C.POL	: POLYESTER FILM CAP	R.MTL.PLAT	: METAL PLATE RESISTOR
C.POLY	: POLYETHYLENE FILM CAP	RSNR.CE	: CERAMIC RESONATOR
C.PP	: POLYPROPYLENE FILM CAP	RSNR.CRYS	: CRYSTAL RESONATOR
C.TNTL	: TANTALUM CAP	R.TW.CEM	: TWIN CEMENT FIXED RESISTOR
C.TNTL.CHP	: CHIP TANTALUM CAP	R.WW	: WIRE WOUND RESISTOR
C.TRIM	: TRIMMER CAP	SCR.BND.HD	: BIND HEAD B-TITE SCREW
CN	: CONNECTOR	SCR.BW.HD	: BW HEAD TAPPING SCREW
CN.BS.PIN	: CONNECTOR,BASE PIN	SCR.CUP	: CUP TITE SCREW
CN.CANNON	: CONNECTOR,CANNON	SCR.TERM	: SCREW TERMINAL
CN.DIN	: CONNECTOR,DIN	SCR.TR	: SCREW,TRANSISTOR
CN.FLAT	: CONNECTOR,FLAT CABLE	SUPRT.PCB	: SUPPORT,P.C.B.
CN.POST	: CONNECTOR,BASE POST	SURG.PRTCT	: SURGE PROTECTOR
COIL.MX.AM	: COIL,AM MIX	SW.TACT	: TACT SWITCH
COIL.AT.FM	: COIL,FM ANTENNA	SW.LEAF	: LEAF SWITCH
COIL.DT.FM	: COIL,FM DETECT	SW.LEVER	: LEVER SWITCH
COIL.MX.FM	: COIL,FM MIX	SW.MICRO	: MICRO SWITCH
COIL.OUTPT	: OUTPUT COIL	SW.PUSH	: PUSH SWITCH
DIOD.ARRAY	: DIODE ARRAY	SW.RT.ENC	: ROTARY ENCODER
DIODE.BRG	: DIODE BRIDGE	SW.RT.MTR	: ROTARY SWITCH WITH MOTOR
DIODE.CHP	: CHIP DIODE	SW.RT	: ROTARY SWITCH
DIODE.VAR	: VARACTOR DIODE	SW.SLIDE	: SLIDE SWITCH
DIOD.Z.CHP	: CHIP ZENER DIODE	TERM.SP	: SPEAKER TERMINAL
DIODE.ZENR	: ZENER DIODE	TERM.WRAP	: WRAPPING TERMINAL
DSCR.CE	: CERAMIC DISCRIMINATOR	THRMST.CHP	: CHIP THERMISTOR
FER.BEAD	: FERRITE BEADS	TR.CHP	: CHIP TRANSISTOR
FER.CORE	: FERRITE CORE	TR.DGT	: DIGITAL TRANSISTOR
FET.CHP	: CHIP FET	TR.DGT.CHP	: CHIP DIGITAL TRANSISTOR
FL.DSPLY	: FLUORESCENT DISPLAY	TRANS	: TRANSFORMER
FLTR.CE	: CERAMIC FILTER	TRANS.PULS	: PULSE TRANSFORMER
FLTR.COMB	: COMB FILTER MODULE	TRANS.PWR	: POWER TRANSFORMER ASS'Y
FLTR.LC.RF	: LC FILTER,EMI	TUNER.AM	: TUNER PACK,AM
GND.MTL	: GROUND PLATE	TUNER.FM	: TUNER PACK,FM
GND.TERM	: GROUND TERMINAL	TUNER.PK	: FRONT-ENDTUNER PACK
HOLDER.FUS	: FUSE HOLDER	VR	: ROTARY POTENTIOMETER
IC.PRTCT	: IC PROTECTOR	VR.MTR	: POTENTIOMETER WITH MOTOR
JUMPER.CN	: JUMPER CONNECTOR	VR.SW	: POTENTIOMETER WITH ROTARY SW
JUMPER.TST	: JUMPER,TEST POINT	VR.SLIDE	: SLIDE POTENTIOMETER
L.DTCT	: LIGHT DETECTING MODULE	VR.TRIM	: TRIMMER POTENTIOMETER

Note) Those parts marked with “#” are not included in the P.C.B. ass'y.

P.C.B. FUNCTION

Schm Ref.	PART NO.	Description	
	V8704300	P. C. B.	FUNCTION
CB301	V7828200	SOCKET	15P TE TUC SERIES
CB302	V7826500	CN	15P TE TUC SERIES
CB303	V7826500	CN	15P TE TUC SERIES
CB304	V7828200	SOCKET	15P TE TUC SERIES
CB305	V7827200	SOCKET	5P TE TUC SERIES
CB307	V7828200	SOCKET	15P TE TUC SERIES
CB308	V0048400	CN	35P
CB309	VK025300	CN. BS. PIN	9P
CB310	VF982200	CN. BS. PIN	14P
CB311	V0044400	CN. BS. PIN	9P
CB312	V0048500	CN	36P TE
CB551	V7827100	SOCKET	4P TE TUC SERIES
CB571	V7825400	CN	4P TE TUC SERIES
CB573	V7825400	CN	4P TE TUC SERIES
CB575	V7825500	CN	5P TE TUC SERIES
CB577	V7826500	CN	15P TE TUC SERIES
CB578	VM859600	CN. BS. PIN	15P
CB601	V7827300	SOCKET	6P TE TUC SERIES
CB602	V0585400	CN. BS. PIN	12P TE
CB603	V0585400	CN. BS. PIN	12P TE
CB921	Vi878100	CN. BS. PIN	3P
CB924	VP206500	HOLDER. FUS	EYF-52BCT
CB925	VP206500	HOLDER. FUS	EYF-52BCT
CB926	VG879900	CN. BS. PIN	2P
C301	UA654100	C. MYLAR	0.01uF 50V
C302	US064100	C. CE. M. CHP	0.01uF 50V
C303	FG651470	C. CE	47pF 50V
C304	FG651470	C. CE	47pF 50V
C305	US061470	C. CE. M. CHP	47pF 50V
C306	US061470	C. CE. M. CHP	47pF 50V
C307	UA652100	C. MYLAR	100pF 50V
C308	UA652100	C. MYLAR	100pF 50V
C309	UA652100	C. MYLAR	100pF 50V
C310	UA652100	C. MYLAR	100pF 50V
C311	UA652100	C. MYLAR	100pF 50V
C312	UA652100	C. MYLAR	100pF 50V
C313	UA652100	C. MYLAR	100pF 50V
C314	UA652100	C. MYLAR	100pF 50V
C315	UA652100	C. MYLAR	100pF 50V
C316	UA652100	C. MYLAR	100pF 50V
C319	UA652100	C. MYLAR	100pF 50V
C320	UA652100	C. MYLAR	100pF 50V
C321	UA652100	C. MYLAR	100pF 50V
C322	UA652100	C. MYLAR	100pF 50V
C323	UA652100	C. MYLAR	100pF 50V
C324	UA652100	C. MYLAR	100pF 50V
C325	UA652100	C. MYLAR	100pF 50V
C326	UA652100	C. MYLAR	100pF 50V
C327	UR877100	C. EL	10uF 63V
C328	UR877100	C. EL	10uF 63V
C329	UR877100	C. EL	10uF 63V
C330	UR877100	C. EL	10uF 63V

* New Parts * 新規部品(マーク#の部品は、基板に含まれません)

Schm Ref.	PART NO.	Description	
C331	UR877100	C. EL	10uF 63V
C332	UR877100	C. EL	10uF 63V
C337	UR838100	C. EL	100uF 16V
C338	UR838100	C. EL	100uF 16V
C339	UR847470	C. EL	47uF 25V
C340	UR847470	C. EL	47uF 25V
C341	UR877100	C. EL	10uF 63V
C342	UR877100	C. EL	10uF 63V
C343	UR866330	C. EL	3.3uF 50V
C345	UR877220	C. EL	22uF 63V
C347	US135100	C. CE. CHP	0.1uF 16V
C348	US135100	C. CE. CHP	0.1uF 16V
C349	UR877100	C. EL	10uF 63V
C350	UR877100	C. EL	10uF 63V
C351	FG651220	C. CE	22pF 50V
C352	FG651220	C. CE	22pF 50V
C353	UA652100	C. MYLAR	100pF 50V
C354	UR877100	C. EL	10uF 63V
C355	UR877100	C. EL	10uF 63V
C356	UR877100	C. EL	10uF 63V
C357	UR877100	C. EL	10uF 63V
C358	UR877100	C. EL	10uF 63V
C361	UR858100	C. EL	100uF 35V
C362	UR858100	C. EL	100uF 35V
C363	US135100	C. CE. CHP	0.1uF 16V
C364	US135100	C. CE. CHP	0.1uF 16V
C367	UR819100	C. EL	1000uF 6.3V
C368	UR866220	C. EL	2.2uF 50V
C369	UR819100	C. EL	1000uF 6.3V
C370	VT180400	C. EL	4700uF 5.5V
C371	UR818220	C. EL	220uF 6.3V
C372	UR865100	C. EL	0.1uF 50V
C375	UR877100	C. EL	10uF 63V
C376	UR865100	C. EL	0.1uF 50V
C377	US135100	C. CE. CHP	0.1uF 16V
C378	UR847470	C. EL	47uF 25V
C379	US064100	C. CE. M. CHP	0.01uF 50V
C383	UA655470	C. MYLAR	0.47uF 50V
C387	UA655470	C. MYLAR	0.47uF 50V
C388	UR877100	C. EL	10uF 63V
C389	UR877100	C. EL	10uF 63V
C390	UR877100	C. EL	10uF 63V
C391	UR877100	C. EL	10uF 63V
C392	US062100	C. CE. M. CHP	100pF 50V
C399	VG278900	C. CE. TUBLR	680pF 50V
C400	UR865100	C. EL	0.1uF 50V
C551	US062100	C. CE. M. CHP	100pF 50V
C552	US062100	C. CE. M. CHP	100pF 50V
C553	UR877100	C. EL	10uF 63V
C554	UR877100	C. EL	10uF 63V
C555	UR877100	C. EL	10uF 63V
C556	UR877100	C. EL	10uF 63V
C557	UR829100	C. EL	1000uF 10V

* New Parts * 新規部品(マーク#の部品は、基板に含まれません)

P.C.B. FUNCTION

Schm Ref.	PART NO.	Description		
C558	UR829100	C. EL	1000uF	10V
C559	US063100	C. CE. M. CHP	1000pF	50V
C562	UR877100	C. EL	10uF	63V
C571	UR847470	C. EL	47uF	25V
C572	UR847470	C. EL	47uF	25V
C584	US062100	C. CE. M. CHP	100pF	50V
C585	US062100	C. CE. M. CHP	100pF	50V
C586	US063100	C. CE. M. CHP	1000pF	50V
C587	US062100	C. CE. M. CHP	100pF	50V
C588	US062100	C. CE. M. CHP	100pF	50V
C589	US064100	C. CE. M. CHP	0.01uF	50V
C590	US135100	C. CE. CHP	0.1uF	16V
C591	UR877100	C. EL	10uF	63V
△ C601	UR73A100	C. EL	10000uF	16V
△ C602	UR749470	C. EL	4700uF	25V
△ C603	UR749470	C. EL	4700uF	25V
△ C604	UR73A100	C. EL	10000uF	16V
C605	UR73A100	C. EL	10000uF	16V
C606	VE326000	C. MYLAR. ML	0.1uF	50V
C607	VE326000	C. MYLAR. ML	0.1uF	50V
C608	VE326000	C. MYLAR. ML	0.1uF	50V
C609	VE326000	C. MYLAR. ML	0.1uF	50V
C610	VE326000	C. MYLAR. ML	0.1uF	50V
C611	VE326000	C. MYLAR. ML	0.1uF	50V
C612	VE326000	C. MYLAR. ML	0.1uF	50V
C613	VE326000	C. MYLAR. ML	0.1uF	50V
C614	UR73A100	C. EL	10000uF	16V
C921	UA655100	C. MYLAR	0.1uF	50V
C922	UR748470	C. EL	470uF	25V
C927	UA654100	C. MYLAR	0.01uF	50V
△ C930	V6185300	C. CE. SAFTY	0.01uF	275V
D301	VU994300	DIODE. ZENR	MA8075-H	7.7V
D302	VU994300	DIODE. ZENR	MA8075-H	7.7V
D303	VU171900	DIODE. ZENR	UDZ5.1B	5.1V
D304	VU171900	DIODE. ZENR	UDZ5.1B	5.1V
D305	VU171900	DIODE. ZENR	UDZ5.1B	5.1V
D306	VT332900	DIODE	1SS355	
D307	VT332900	DIODE	1SS355	
D308	VT332900	DIODE	1SS355	
D309	VT332900	DIODE	1SS355	
D310	VU172200	DIODE. ZENR	UDZ6.8B	6.8V
D311	VT332900	DIODE	1SS355	
D312	VU172000	DIODE. ZENR	UDZS5.6B	5.6V
D313	VU172000	DIODE. ZENR	UDZS5.6B	5.6V
D314	VT332900	DIODE	1SS355	
D315	VT332900	DIODE	1SS355	
D571	VU172000	DIODE. ZENR	UDZS5.6B	5.6V
D572	VT332900	DIODE	1SS355	
△ D601	VQ379300	DIODE. BRG	S1VB20	1A 200V
△ D602	VQ379300	DIODE. BRG	S1VB20	1A 200V
D921	VT332900	DIODE	1SS355	
D924	VV307700	DIODE	1N4002S	
D925	VV307700	DIODE	1N4002S	

* New Parts * 新規部品(マーク#の部品は、基板に含まれません)

Schm Ref.	PART NO.	Description		
D927	VV307700	DIODE	1N4002S	
D928	VV307700	DIODE	1N4002S	
△ F922	VP909900	FUSE	T7A	125V
G601	V8880000	TERM. GND	M3.5	RJP9899
IC301	X2340B00	IC	M30624MGA	MASK ROM
IC302	X2261A00	IC	BD3811K1	
IC303	XF291A00	IC	uPC4570G2	
IC304	XF291A00	IC	uPC4570G2	
IC305	XY877A00	IC	MM74HC4053SJX	
IC306	XJ757A00	IC	NJM78L05A-T3	
IC551	XH436A00	IC	LA7956	
L571	VU889500	COIL	220uH	
PJ301	V7190400	JACK. PIN	6P	
PJ302	V7046800	JACK. PIN	MSP-246V1-01N1	
PJ303	V7046800	JACK. PIN	MSP-246V1-01N1	
PJ304	V7046700	JACK. PIN	MSP-244V1-01N1	
PJ305	V7189700	JACK. PIN	1P	
PJ551	V7190000	JACK. PIN	2P	
PJ552	V7190000	JACK. PIN	2P	
PJ553	V7190000	JACK. PIN	2P	
PN301	V3750200	PIN	L=70	
PN302	V3750200	PIN	L=70	
PN501	V3750200	PIN	L=70	
PN601	V3750200	PIN	L=70	
Q301	VD303700	TR	2SC3326	A, B
Q304	iC181510	TR	2SC1815	Y
Q305	iA101510	TR	2SA1015	Y
Q307	VV556500	TR	2SA1037K	Q, R, S
Q308	VV556400	TR	2SC2412K	Q, R, S
Q309	VV556500	TR	2SA1037K	Q, R, S
Q311	VD303700	TR	2SC3326	A, B
Q551	iC181510	TR	2SC1815	Y
Q553	iC181510	TR	2SC1815	Y
Q555	iC181510	TR	2SC1815	Y
Q571	iC181510	TR	2SC1815	Y
Q921	iC181510	TR	2SC1815	Y
R413	HV753220	R. CAR. FP	2.2Ω	1/4W
R414	HV753220	R. CAR. FP	2.2Ω	1/4W
R570	HV753220	R. CAR. FP	2.2Ω	1/4W
R581	HV753220	R. CAR. FP	2.2Ω	1/4W
R925	V6730000	R. CAR.	2.2MΩ	1/2W
△ RY921	V2712300	RELAY	DC SDT-S-112LMR	
ST301	V4040500	SCR. TERM	M3	
ST571	V4040500	SCR. TERM	M3	
ST921	V4040500	SCR. TERM	M3	
△ T921	XW606A00	TRANS. PWR		
△ TE921	VU543100	OUTLET. AC	2P	
XL301	V7718300	RSNR. CE	CSTLS10M0G53-B0	

* New Parts * 新規部品(マーク#の部品は、基板に含まれません)

P.C.B. OPERATION & P.C.B. DSP

Schm Ref.	PART NO.	Description	
	V8705200	P. C. B.	OPERATION
CB701	VQ047200	CN. BS. PIN	9P
CB702	VQ047200	CN. BS. PIN	9P
CB703	VN394900	CN. BS. PIN	14P
CB704	Vi878000	CN. BS. PIN	2P
CB705	Vi878100	CN. BS. PIN	3P
CB741	Vi878700	CN. BS. PIN	9P
CB781	Vi878000	CN. BS. PIN	2P
CB786	Vi878100	CN. BS. PIN	3P
C701	US062680	C. CE. M. CHP	680pF 50V
C702	US062680	C. CE. M. CHP	680pF 50V
C703	UR877100	C. EL	10uF 63V
C704	US061330	C. CE. M. CHP	33pF 50V
C705	US135100	C. CE. CHP	0.1uF 16V
C741	UR838330	C. EL	330uF 16V
C742	UR838330	C. EL	330uF 16V
C743	UR866100	C. EL	1uF 50V
C744	UR866100	C. EL	1uF 50V
C745	UR866220	C. EL	2.2uF 50V
C746	UR866220	C. EL	2.2uF 50V
C747	UT652100	C. PP	100pF 100V
C748	UT652100	C. PP	100pF 100V
C749	UR847470	C. EL	47uF 25V
C750	UR847470	C. EL	47uF 25V
C751	UA655120	C. MYLAR	0.12uF 50V
C752	UA655120	C. MYLAR	0.12uF 50V
C753	UA654330	C. MYLAR	0.033uF 50V
C754	UA654330	C. MYLAR	0.033uF 50V
C755	UR877220	C. EL	22uF 63V
C756	UR877220	C. EL	22uF 63V
C757	UR877100	C. EL	10uF 63V
C758	UR877100	C. EL	10uF 63V
C760	US062100	C. CE. M. CHP	100pF 50V
C761	US062100	C. CE. M. CHP	100pF 50V
C762	US062100	C. CE. M. CHP	100pF 50V
C763	US135100	C. CE. CHP	0.1uF 16V
C764	US135100	C. CE. CHP	0.1uF 16V
C765	UA652100	C. MYLAR	100pF 50V
C766	UA652100	C. MYLAR	100pF 50V
D701	VU172300	DIODE. ZENR	UDZ7.5B 7.5V
G701	V8880000	TERM. GND	M3.5 RJP9899
IC701	XV160A00	IC	LC75712E FLD
IC741	XF291A00	IC	uPC4570G2
IC742	XF291A00	IC	uPC4570G2
PN781	V3750200	PIN	L=70
Q701	VV900500	TR	2SD1991A Q, R, S
Q702	VV900500	TR	2SD1991A Q, R, S
Q703	VV900500	TR	2SD1991A Q, R, S
Q704	VV900500	TR	2SD1991A Q, R, S
Q705	VV900500	TR	2SD1991A Q, R, S
Q706	VV900500	TR	2SD1991A Q, R, S
Q707	VV900500	TR	2SD1991A Q, R, S
Q708	VV900500	TR	2SD1991A Q, R, S

* New Parts * 新規部品(マーク#の部品は、基板に含まれません)

Schm Ref.	PART NO.	Description	
Q709	VV900500	TR	2SD1991A Q, R, S
R741	V8070300	R. MTL. FLM	10Ω 1W
R742	V8070300	R. MTL. FLM	10Ω 1W
SW701	VV020300	SW. TACT	SKQNAA
SW702	VV020300	SW. TACT	SKQNAA
SW703	VV020300	SW. TACT	SKQNAA
SW704	VV020300	SW. TACT	SKQNAA
SW705	VV020300	SW. TACT	SKQNAA
SW706	VV020300	SW. TACT	SKQNAA
SW707	VV020300	SW. TACT	SKQNAA
SW708	VV020300	SW. TACT	SKQNAA
SW709	VV020300	SW. TACT	SKQNAA
SW710	VV020300	SW. TACT	SKQNAA
SW715	VV020300	SW. TACT	SKQNAA
SW716	VV020300	SW. TACT	SKQNAA
SW717	VV020300	SW. TACT	SKQNAA
SW718	VV020300	SW. TACT	SKQNAA
SW719	V6322700	SW. RT. ENC	REB161 (9X7)PVB
SW781	VV020300	SW. TACT	SKQNAA
U701	V8444900	L. DTCT	GP1UM271XK
V701	V8300400	FL. DSPLY	HNA-16MM37
VR741	V7455900	VR	B 20K RK14K1240
VR742	V7456000	VR	W 25K RK14K1240
	V6880300	SHEET	
	V6007100	SPACER	4.6/10/32
	V8702000	P. C. B.	DSP
CB602	VQ046400	CN. BS. PIN	35P SE
C600	US061220	C. CE. M. CHP	22pF 50V
C603	US135100	C. CE. CHP	0.1uF 16V
C605	US135100	C. CE. CHP	0.1uF 16V
C606	UR847220	C. EL	22uF 25V
C610	US061100	C. CE. M. CHP	10pF 50V
C613	US062220	C. CE. CHP	220pF 50V
C614	US063100	C. CE. M. CHP	1000pF 50V
C622	UR819100	C. EL	1000uF 6.3V
C623	VJ599100	C. CE. TUBLR	0.1uF 50V
C628	US135100	C. CE. CHP	0.1uF 16V
C630	US135100	C. CE. CHP	0.1uF 16V
C632	UR819100	C. EL	1000uF 6.3V
C634	UR819100	C. EL	1000uF 6.3V
C636	US135100	C. CE. CHP	0.1uF 16V
C637	UR818100	C. EL	100uF 6.3V
C638	UR819100	C. EL	1000uF 6.3V
C639	US135100	C. CE. CHP	0.1uF 16V
C640	US135100	C. CE. CHP	0.1uF 16V
C641	US135100	C. CE. CHP	0.1uF 16V
C642	US135100	C. CE. CHP	0.1uF 16V
C643	UR818470	C. EL	470uF 6.3V
C644	UR818100	C. EL	100uF 6.3V
C645	US135100	C. CE. CHP	0.1uF 16V

* New Parts * 新規部品(マーク#の部品は、基板に含まれません)

P.C.B. DSP

Schm Ref.	PART NO.	Description		
C646	US061330	C. CE. M. CHP	33pF	50V
C647	US135100	C. CE. CHP	0.1uF	16V
C648	US061330	C. CE. M. CHP	33pF	50V
C649	US135100	C. CE. CHP	0.1uF	16V
C650	UR818470	C. EL	470uF	6.3V
C651	US062470	C. CE. M. CHP	470pF	50V
C654	US061470	C. CE. M. CHP	47pF	50V
C656	US061470	C. CE. M. CHP	47pF	50V
C657	US061470	C. CE. M. CHP	47pF	50V
C663	US061470	C. CE. M. CHP	47pF	50V
C664	US061470	C. CE. M. CHP	47pF	50V
C665	UR818100	C. EL	100uF	6.3V
C667	US135100	C. CE. CHP	0.1uF	16V
C668	US135100	C. CE. CHP	0.1uF	16V
C669	US135100	C. CE. CHP	0.1uF	16V
C670	US063470	C. CE. CHP	4700pF	50V
C674	US135100	C. CE. CHP	0.1uF	16V
C678	US063470	C. CE. CHP	4700pF	50V
C679	UR818100	C. EL	100uF	6.3V
C680	US135100	C. CE. CHP	0.1uF	16V
C681	US135100	C. CE. CHP	0.1uF	16V
C688	UR818100	C. EL	100uF	6.3V
C689	US135100	C. CE. CHP	0.1uF	16V
C690	UR819100	C. EL	1000uF	6.3V
C691	US135100	C. CE. CHP	0.1uF	16V
C694	US135100	C. CE. CHP	0.1uF	16V
C695	UR819100	C. EL	1000uF	6.3V
C698	US135100	C. CE. CHP	0.1uF	16V
C699	US061470	C. CE. M. CHP	47pF	50V
C700	US061470	C. CE. M. CHP	47pF	50V
C701	US061470	C. CE. M. CHP	47pF	50V
C702	US061470	C. CE. M. CHP	47pF	50V
C703	US061470	C. CE. M. CHP	47pF	50V
C704	US061470	C. CE. M. CHP	47pF	50V
C705	US061470	C. CE. M. CHP	47pF	50V
C706	US061470	C. CE. M. CHP	47pF	50V
C707	US061470	C. CE. M. CHP	47pF	50V
C708	US061470	C. CE. M. CHP	47pF	50V
C709	US061470	C. CE. M. CHP	47pF	50V
C710	US061470	C. CE. M. CHP	47pF	50V
C711	US135100	C. CE. CHP	0.1uF	16V
C712	US135100	C. CE. CHP	0.1uF	16V
C713	US135100	C. CE. CHP	0.1uF	16V
C714	US135100	C. CE. CHP	0.1uF	16V
C715	UR818100	C. EL	100uF	6.3V
C716	UR818100	C. EL	100uF	6.3V
C717	US135100	C. CE. CHP	0.1uF	16V
C718	US135100	C. CE. CHP	0.1uF	16V
C719	US135100	C. CE. CHP	0.1uF	16V
C720	UR866220	C. EL	2.2uF	50V
C721	UR828100	C. EL	100uF	10V
C730	UA653150	C. MYLAR	1500pF	50V
C731	UA653150	C. MYLAR	1500pF	50V

* New Parts * 新規部品(マーク#の部品は、基板に含まれません)

Schm Ref.	PART NO.	Description		
C736	UA652100	C. MYLAR	100pF	50V
C737	UA652100	C. MYLAR	100pF	50V
C742	UR847100	C. EL	10uF	25V
C743	UR866220	C. EL	2.2uF	50V
C744	UR866220	C. EL	2.2uF	50V
C745	UR847100	C. EL	10uF	25V
C746	UR866220	C. EL	2.2uF	50V
C747	UR866220	C. EL	2.2uF	50V
C756	UA652100	C. MYLAR	100pF	50V
C757	UA652100	C. MYLAR	100pF	50V
C758	UA652470	C. MYLAR	470pF	50V
C759	UA652470	C. MYLAR	470pF	50V
C760	UA652470	C. MYLAR	470pF	50V
C761	UA652470	C. MYLAR	470pF	50V
C762	UA652470	C. MYLAR	470pF	50V
C763	UA652470	C. MYLAR	470pF	50V
C764	UR847100	C. EL	10uF	25V
C765	UR847100	C. EL	10uF	25V
C766	UR866220	C. EL	2.2uF	50V
C767	UR866220	C. EL	2.2uF	50V
C768	UR866220	C. EL	2.2uF	50V
C769	UR866220	C. EL	2.2uF	50V
C770	UR847100	C. EL	10uF	25V
C771	US135100	C. CE. CHP	0.1uF	16V
C772	UR847220	C. EL	22uF	25V
C773	UR847220	C. EL	22uF	25V
C774	UR837470	C. EL	47uF	16V
C775	UR837470	C. EL	47uF	16V
C776	UR837470	C. EL	47uF	16V
C777	UR837470	C. EL	47uF	16V
C778	US135100	C. CE. CHP	0.1uF	16V
C779	US135100	C. CE. CHP	0.1uF	16V
C780	US135100	C. CE. CHP	0.1uF	16V
C781	US135100	C. CE. CHP	0.1uF	16V
C782	US135100	C. CE. CHP	0.1uF	16V
C791	US135100	C. CE. CHP	0.1uF	16V
C793	US135100	C. CE. CHP	0.1uF	16V
C794	US135100	C. CE. CHP	0.1uF	16V
C795	US135100	C. CE. CHP	0.1uF	16V
D600	VT332900	DIODE	1SS355	
D601	VT332900	DIODE	1SS355	
D604	VT332900	DIODE	1SS355	
D605	VT332900	DIODE	1SS355	
D606	VT332900	DIODE	1SS355	
D607	VT332900	DIODE	1SS355	
D608	VV220700	DIODE. SHOT	RB501V-40	
D609	VV220700	DIODE. SHOT	RB501V-40	
D610	VV220700	DIODE. SHOT	RB501V-40	
D611	VV220700	DIODE. SHOT	RB501V-40	
D612	VV220700	DIODE. SHOT	RB501V-40	
D613	VV220700	DIODE. SHOT	RB501V-40	
D614	VV220700	DIODE. SHOT	RB501V-40	
D615	VV220700	DIODE. SHOT	RB501V-40	

* New Parts * 新規部品(マーク#の部品は、基板に含まれません)

P.C.B. DSP & P.C.B. MAIN

Schm Ref.	PART NO.	Description	
G601	V8880000	TERM. GND	M3.5 RJP9899
G602	V8880000	TERM. GND	M3.5 RJP9899
G603	V8880000	TERM. GND	M3.5 RJP9899
IC600	X0238A00	IC	YSS938-F
IC601	XV077A00	IC	MSM514260C-60JS
IC602	XZ003A00	IC	PQ025EZ5MZP 2.5V
IC603	XU965A00	IC	uPC29M33T-E1 3.3V
IC607	XD660A00	IC	TC74HCU04AF-TP1
IC610	XZ012A00	IC	TC74HCT08AF(EL)
IC614	X0237A00	IC	AK4527BVQ
IC617	XF291A00	IC	uPC4570G2
IC618	XF291A00	IC	uPC4570G2
IC619	XF291A00	IC	uPC4570G2
IC620	XF291A00	IC	uPC4570G2
IC621	XF291A00	IC	uPC4570G2
L602	V2726500	COIL	68uH
PJ600	V4483900	JACK. PIN	YKC21-3895
Q601	VC124000	TR. DGT	DTA144EK
Q602	VD303700	TR	2SC3326 A, B
Q603	VD303700	TR	2SC3326 A, B
Q604	VD303700	TR	2SC3326 A, B
R613	HV753220	R. CAR. FP	2.2Ω 1/4W
R661	HV753220	R. CAR. FP	2.2Ω 1/4W
R684	HV753220	R. CAR. FP	2.2Ω 1/4W
R692	HV753100	R. CAR. FP	1Ω 1/4W
R693	HV753100	R. CAR. FP	1Ω 1/4W
R694	VU224000	R. MTL. FLM	0.22Ω 1W
R717	HV753220	R. CAR. FP	2.2Ω 1/4W
R730	HV753220	R. CAR. FP	2.2Ω 1/4W
R776	HV753220	R. CAR. FP	2.2Ω 1/4W
R777	HV753220	R. CAR. FP	2.2Ω 1/4W
R794	HV753100	R. CAR. FP	1Ω 1/4W
U602	V5478200	CN. PHOT. SN	1P GP1FA551RZ
XL600	V3625700	RSNR. CRYST	24.576MHz
	V8701100	P. C. B.	MAIN
CB101	V7826600	CN	16P TE TUC SERIES
CB102	V7826300	CN	13P TE TUC SERIES
CB103	Vi878200	CN. BS. PIN	4P
CB104	Vi878500	CN. BS. PIN	7P
CB105	VR428800	CN. BS. PIN	3P
CB110	VR428800	CN. BS. PIN	3P
CB112	VR428800	CN. BS. PIN	3P
CB251	V7828300	SOCKET	16P TE TUC SERIES
CB252	V7828000	SOCKET	13P TE TUC SERIES
CB253	VQ046500	CN. BS. PIN	36P SE
CB254	Vi878700	CN. BS. PIN	9P
CB371	Vi878200	CN. BS. PIN	4P
CB381	VK025100	CN. BS. PIN	7P
CB382	VK024700	CN. BS. PIN	3P
CB384	VQ585200	CN. BS. PIN	10P

* New Parts * 新規部品(マーク#の部品は、基板に含まれません)

Schm Ref.	PART NO.	Description	
CB385	VQ585200	CN. BS. PIN	10P
CB386	VQ584700	CN. BS. PIN	5P
CB391	VR428800	CN. BS. PIN	3P
CB392	VR428800	CN. BS. PIN	3P
CB393	VR428800	CN. BS. PIN	3P
CB394	VQ584700	CN. BS. PIN	5P
CB401	Vi878700	CN. BS. PIN	9P
CB402	V7825600	CN	6P TE TUC SERIES
C101	UR867470	C. EL	47uF 50V
C102	VR325000	C. MYLAR	100pF 100V
C103	UR847470	C. EL	47uF 25V
C104	VR325000	C. MYLAR	100pF 100V
C105	VK399200	C. MYLAR. ML	0.39uF 50V
C106	UA654680	C. MYLAR	0.068uF 50V
C107	UR867470	C. EL	47uF 50V
C108	VR325000	C. MYLAR	100pF 100V
C109	UR847470	C. EL	47uF 25V
C110	VR325000	C. MYLAR	100pF 100V
C111	VK399200	C. MYLAR. ML	0.39uF 50V
C112	UA654680	C. MYLAR	0.068uF 50V
C113	UR867470	C. EL	47uF 50V
C114	VR325000	C. MYLAR	100pF 100V
C115	UR847470	C. EL	47uF 25V
C116	VR325000	C. MYLAR	100pF 100V
C117	UA654680	C. MYLAR	0.068uF 50V
C118	UR867470	C. EL	47uF 50V
C119	VR325000	C. MYLAR	100pF 100V
C120	UR847470	C. EL	47uF 25V
C121	VR325000	C. MYLAR	100pF 100V
C122	UA654680	C. MYLAR	0.068uF 50V
C123	UR867470	C. EL	47uF 50V
C124	VR325000	C. MYLAR	100pF 100V
C125	UR847470	C. EL	47uF 25V
C126	VR325000	C. MYLAR	100pF 100V
C127	UA654680	C. MYLAR	0.068uF 50V
C128	UR877220	C. EL	22uF 63V
C129	UR876470	C. EL	4.7uF 63V
C130	VT898000	C. MYLAR	0.1uF 100V
C131	VT898000	C. MYLAR	0.1uF 100V
C132	UR866470	C. EL	4.7uF 50V
C133	V8584600	C. PP	220pF 630V
C134	UR847470	C. EL	47uF 25V
C135	UR818100	C. EL	100uF 6.3V
C136	UR866470	C. EL	4.7uF 50V
C137	UR866470	C. EL	4.7uF 50V
C251	UR877220	C. EL	22uF 63V
C252	UR877220	C. EL	22uF 63V
C253	UR877100	C. EL	10uF 63V
C254	VQ462600	C. MYLAR	220pF 50V
C255	VQ462600	C. MYLAR	220pF 50V
C256	UA653100	C. MYLAR	1000pF 50V
C257	UR868100	C. EL	100uF 50V
C258	V8584300	C. PP	33pF 630V

* New Parts * 新規部品(マーク#の部品は、基板に含まれません)

P.C.B. MAIN

Schm Ref.	PART NO.	Description
C259	UR877100	C. EL 10uF 63V
C260	VQ462600	C. MYLAR 220pF 50V
C261	VQ462600	C. MYLAR 220pF 50V
C262	UA653100	C. MYLAR 1000pF 50V
C263	UR868100	C. EL 100uF 50V
C264	V8584300	C. PP 33pF 630V
C265	UR877100	C. EL 10uF 63V
C266	UA652220	C. MYLAR 220pF 50V
C267	UA652220	C. MYLAR 220pF 50V
C268	UA653100	C. MYLAR 1000pF 50V
C269	UR857470	C. EL 47uF 35V
C270	VS696700	C. CE 33pF 500V
C271	UR877100	C. EL 10uF 63V
C272	UA652220	C. MYLAR 220pF 50V
C273	UA652220	C. MYLAR 220pF 50V
C274	UA653100	C. MYLAR 1000pF 50V
C275	UR857470	C. EL 47uF 35V
C276	VS696700	C. CE 33pF 500V
C277	UR877100	C. EL 10uF 63V
C278	VQ462600	C. MYLAR 220pF 50V
C279	UA652220	C. MYLAR 220pF 50V
C280	UA653100	C. MYLAR 1000pF 50V
C281	UR867470	C. EL 47uF 50V
C282	V8584300	C. PP 33pF 630V
C283	UT653100	C. PP 1000pF 100V
C284	UR838100	C. EL 100uF 16V
C375	UA653100	C. MYLAR 1000pF 50V
C381	V4926300	C. EL 8200uF 63V
C382	V4926300	C. EL 8200uF 63V
C384	VT898000	C. MYLAR 0. 1uF 100V
C385	VT898000	C. MYLAR 0. 1uF 100V
C386	VG291300	C. EL 100uF 50V
C387	VG291300	C. EL 100uF 50V
C388	UA655100	C. MYLAR 0. 1uF 50V
C389	UA655100	C. MYLAR 0. 1uF 50V
C401	VG287600	C. EL 100uF 25V
C402	VG287600	C. EL 100uF 25V
C403	VG288500	C. EL 10uF 25V
C404	VG288500	C. EL 10uF 25V
C405	UR838100	C. EL 100uF 16V
C406	UR838100	C. EL 100uF 16V
C407	UR877100	C. EL 10uF 63V
C408	UR877100	C. EL 10uF 63V
C409	UR838100	C. EL 100uF 16V
C410	UR877100	C. EL 10uF 63V
C411	VD930900	C. CE. SMI 0. 1uF 25V
D101	VN008700	DIODE 1SS270A
D102	VN008700	DIODE 1SS270A
D103	VN008700	DIODE 1SS270A
D104	VN008700	DIODE 1SS270A
D105	VN008700	DIODE 1SS270A
D106	VN008700	DIODE 1SS270A
D107	VN008700	DIODE 1SS270A

* New Parts * 新規部品(マーク#の部品は、基板に含まれません)

Schm Ref.	PART NO.	Description
D108	VN008700	DIODE 1SS270A
D109	VN008700	DIODE 1SS270A
D110	VN008700	DIODE 1SS270A
D111	VD631600	DIODE 1SS133, 176
D112	VD631600	DIODE 1SS133, 176
D113	VD631600	DIODE 1SS133, 176
D114	VD631600	DIODE 1SS133, 176
D115	VG440300	DIODE. ZENR MTZJ12C 12V
D116	VG440300	DIODE. ZENR MTZJ12C 12V
D117	VN008700	DIODE 1SS270A
D118	VN008700	DIODE 1SS270A
D119	VG437200	DIODE. ZENR MTZJ4. 7C 4. 7V
D120	VG440300	DIODE. ZENR MTZJ12C 12V
D121	VG440300	DIODE. ZENR MTZJ12C 12V
D122	VG443200	DIODE. ZENR MTZJ30A 30V
D123	VN008700	DIODE 1SS270A
D124	VN008700	DIODE 1SS270A
D125	VN008700	DIODE 1SS270A
D127	VG440300	DIODE. ZENR MTZJ12C 12V
D128	VG440300	DIODE. ZENR MTZJ12C 12V
D129	VG440300	DIODE. ZENR MTZJ12C 12V
D130	VG440300	DIODE. ZENR MTZJ12C 12V
D251	VD631600	DIODE 1SS133, 176
D252	VG440300	DIODE. ZENR MTZJ12C 12V
D253	VG438300	DIODE. ZENR MTZJ6. 8B 6. 8V
D254	VG440300	DIODE. ZENR MTZJ12C 12V
D255	VD631600	DIODE 1SS133, 176
D256	VD631600	DIODE 1SS133, 176
D257	VG440300	DIODE. ZENR MTZJ12C 12V
D371	VD631600	DIODE 1SS133, 176
D372	VD631600	DIODE 1SS133, 176
D373	VG439200	DIODE. ZENR MTZJ9. 1B 9. 1V
D381	VM702000	DIODE. BRG S5VB20 3. 5A 200V
D382	VS997800	DIODE 1T2
D383	VS997800	DIODE 1T2
D384	VS997800	DIODE 1T2
D385	VS997800	DIODE 1T2
G381	V8880000	TERM. GND M3. 5 RJP9899
IC401	XJ608A00	IC NJM7812FA
IC402	XD343A00	IC NJM79M12FA
IC403	XJ607A00	IC NJM7805FA 5V
IC404	XE436A00	IC NJM79M05FA
IC405	XJ607A00	IC NJM7805FA 5V
IC406	X0515A00	IC LM61C1Z THERMAL
JK371	V4164400	JACK. PHONE YKB21-5209
L101	VU038200	COIL 0. 95uH
L102	VU038200	COIL 0. 95uH
L103	V2604200	COIL 1uH
L104	V2604200	COIL 1uH
L105	V2604200	COIL 1uH
PN101	V3750200	PIN L=70
PN102	V3750200	PIN L=70
PN251	V3750200	PIN L=70

* New Parts * 新規部品(マーク#の部品は、基板に含まれません)

P.C.B. MAIN

Schm Ref.	PART NO.	Description
PN331	V3750200	PIN L=70
PN351	V3750200	PIN L=70
PN395	V3750200	PIN L=70
△ Q101	VK432900	TR 2SD1915F S,T
△ Q102	V4096100	TR 2SC4614 S,T
△ Q103	V4096000	TR 2SA1770 S,T
△ Q104A	iX630850	TR 2SA1695 O,P,Y
△ Q104C	iX630860	TR 2SC4468 O,P,Y
Q105	VP883100	TR 2SC1890A D,E
△ Q106	VK432900	TR 2SD1915F S,T
△ Q107	V4096100	TR 2SC4614 S,T
△ Q108	V4096000	TR 2SA1770 S,T
△ Q109A	iX630850	TR 2SA1695 O,P,Y
△ Q109C	iX630860	TR 2SC4468 O,P,Y
Q110	VP883100	TR 2SC1890A D,E
△ Q111	VK432900	TR 2SD1915F S,T
△ Q112	V4096100	TR 2SC4614 S,T
△ Q113	V4096000	TR 2SA1770 S,T
△ Q114A	iX630850	TR 2SA1695 O,P,Y
△ Q114C	iX630860	TR 2SC4468 O,P,Y
Q115	VP883100	TR 2SC1890A D,E
△ Q116	VK432900	TR 2SD1915F S,T
△ Q117	V4096100	TR 2SC4614 S,T
△ Q118	V4096000	TR 2SA1770 S,T
△ Q119A	iX630850	TR 2SA1695 O,P,Y
△ Q119C	iX630860	TR 2SC4468 O,P,Y
Q120	VP883100	TR 2SC1890A D,E
△ Q121	VK432900	TR 2SD1915F S,T
Q122	VP883000	TR 2SA893A D,E
△ Q123	V4096100	TR 2SC4614 S,T
△ Q124	V4096000	TR 2SA1770 S,T
△ Q125A	iX630850	TR 2SA1695 O,P,Y
△ Q125C	iX630860	TR 2SC4468 O,P,Y
Q126	VP883100	TR 2SC1890A D,E
△ Q127	VS883300	TR 2SB1565 E,F
△ Q128	VP883000	TR 2SA893A D,E
Q129	iC181510	TR 2SC1815 Y
Q130	VP883000	TR 2SA893A D,E
Q131	iC181510	TR 2SC1815 Y
Q132	iC181510	TR 2SC1815 Y
△ Q133	iA101510	TR 2SA1015 Y
Q134	iC181510	TR 2SC1815 Y
Q137	VP883100	TR 2SC1890A D,E
Q138	VP883100	TR 2SC1890A D,E
Q251	VP883100	TR 2SC1890A D,E
△ Q252	VR510800	TR 2SD2396 J,K
Q253	VP883100	TR 2SC1890A D,E
Q254	VP883100	TR 2SC1890A D,E
Q255	VP883100	TR 2SC1890A D,E
Q256	V3966800	TR 2SB949 O,Y
Q257	VP883100	TR 2SC1890A D,E
Q258	VP883100	TR 2SC1890A D,E
Q259	V3966800	TR 2SB949 O,Y

* New Parts * 新規部品(マーク#の部品は、基板に含まれません)

Schm Ref.	PART NO.	Description
Q260	VP883100	TR 2SC1890A D,E
Q261	VP883100	TR 2SC1890A D,E
Q262	V3966800	TR 2SB949 O,Y
Q263	VP883100	TR 2SC1890A D,E
Q264	VP883100	TR 2SC1890A D,E
Q265	V3966800	TR 2SB949 O,Y
Q266	VP883100	TR 2SC1890A D,E
Q267	VP883100	TR 2SC1890A D,E
Q268	V3966800	TR 2SB949 O,Y
R101	HL006270	R. MTL. OXD 2.7KΩ 1/2W
R102	HL005390	R. MTL. OXD 390Ω 1/2W
R103	HL005820	R. MTL. OXD 820Ω 1/2W
R104	V8072100	R. MTL. OXD 5.6KΩ 1W
R105	V8072100	R. MTL. OXD 5.6KΩ 1W
R106	HL006100	R. MTL. OXD 1KΩ 1/2W
R107	HV755100	R. CAR. FP 100Ω 1/4W
△ R108	V8071100	R. MTL. FLM 220Ω 1W
△ R109	V8070200	R. MTL. FLM 4.7Ω 1W
△ R111	V8070200	R. MTL. FLM 4.7Ω 1W
△ R113	V3873200	R. WW 0.22Ω 3W
△ R117	V8070300	R. MTL. FLM 10Ω 1W
R119	HV754100	R. CAR. FP 10Ω 1/4W
R121	HL006270	R. MTL. OXD 2.7KΩ 1/2W
R122	HL005390	R. MTL. OXD 390Ω 1/2W
R123	HL005820	R. MTL. OXD 820Ω 1/2W
R124	V8072100	R. MTL. OXD 5.6KΩ 1W
R125	V8072100	R. MTL. OXD 5.6KΩ 1W
R126	HL006100	R. MTL. OXD 1KΩ 1/2W
R127	HV755100	R. CAR. FP 100Ω 1/4W
△ R128	V8071100	R. MTL. FLM 220Ω 1W
△ R129	V8070200	R. MTL. FLM 4.7Ω 1W
△ R131	V8070200	R. MTL. FLM 4.7Ω 1W
△ R133	V3873200	R. WW 0.22Ω 3W
△ R137	V8070300	R. MTL. FLM 10Ω 1W
R139	HV754100	R. CAR. FP 10Ω 1/4W
R141	HL006270	R. MTL. OXD 2.7KΩ 1/2W
R142	HL005390	R. MTL. OXD 390Ω 1/2W
R143	HL005820	R. MTL. OXD 820Ω 1/2W
R144	V8072100	R. MTL. OXD 5.6KΩ 1W
R145	V8072100	R. MTL. OXD 5.6KΩ 1W
R146	HL006100	R. MTL. OXD 1KΩ 1/2W
R147	HV755100	R. CAR. FP 100Ω 1/4W
△ R148	V8071100	R. MTL. FLM 220Ω 1W
△ R149	HV754100	R. CAR. FP 10Ω 1/4W
△ R150	HV754100	R. CAR. FP 10Ω 1/4W
△ R151	VU981700	R. MTL. PLAT 0.22Ω+0.22 3W
△ R155	V8070300	R. MTL. FLM 10Ω 1W
R158	HV754100	R. CAR. FP 10Ω 1/4W
R159	HL006270	R. MTL. OXD 2.7KΩ 1/2W
R160	HL005390	R. MTL. OXD 390Ω 1/2W
R161	HL005820	R. MTL. OXD 820Ω 1/2W
R162	V8072100	R. MTL. OXD 5.6KΩ 1W
R163	V8072100	R. MTL. OXD 5.6KΩ 1W

* New Parts * 新規部品(マーク#の部品は、基板に含まれません)

P.C.B. MAIN & Chip Resistors

Schm Ref.	PART NO.	Description		
R164	HL006100	R. MTL. OXD	1K Ω	1/2W
R165	HV755100	R. CAR. FP	100 Ω	1/4W
△ R166	V8071100	R. MTL. FLM	220 Ω	1W
△ R167	HV754100	R. CAR. FP	10 Ω	1/4W
△ R168	HV754100	R. CAR. FP	10 Ω	1/4W
△ R169	VU981700	R. MTL. PLAT	0.22 Ω +0.22	3W
△ R174	V8070300	R. MTL. FLM	10 Ω	1W
R176	HV754100	R. CAR. FP	10 Ω	1/4W
R177	V8072100	R. MTL. OXD	5.6K Ω	1W
R178	HV755100	R. CAR. FP	100 Ω	1/4W
R179	V8072100	R. MTL. OXD	5.6K Ω	1W
R180	HL006270	R. MTL. OXD	2.7K Ω	1/2W
R181	HL005390	R. MTL. OXD	390 Ω	1/2W
R182	HL005820	R. MTL. OXD	820 Ω	1/2W
R183	HL006100	R. MTL. OXD	1K Ω	1/2W
△ R184	V8071100	R. MTL. FLM	220 Ω	1W
△ R185	V8070300	R. MTL. FLM	10 Ω	1W
△ R186	V8070300	R. MTL. FLM	10 Ω	1W
△ R187	V3873200	R. WW	0.22 Ω	3W
△ R191	V8070300	R. MTL. FLM	10 Ω	1W
R194	HV754100	R. CAR. FP	10 Ω	1/4W
△ R199	HV754100	R. CAR. FP	10 Ω	1/4W
△ R202	HV756150	R. CAR. FP	1.5K Ω	1/4W
△ R205	V8070200	R. MTL. FLM	4.7 Ω	1W
△ R206	V8070200	R. MTL. FLM	4.7 Ω	1W
△ R210	V8070200	R. MTL. FLM	4.7 Ω	1W
△ R211	V8071300	R. MTL. FLM	470 Ω	1W
R213	V8071400	R. MTL. FLM	560 Ω	1W
R214	V8071400	R. MTL. FLM	560 Ω	1W
△ R219	V8071300	R. MTL. FLM	470 Ω	1W
△ R223	HV756100	R. CAR. FP	1K Ω	1/4W
△ R224	HV755100	R. CAR. FP	100 Ω	1/4W
△ R231	V8071300	R. MTL. FLM	470 Ω	1W
△ R232	V8071300	R. MTL. FLM	470 Ω	1W
△ R255	HV754100	R. CAR. FP	10 Ω	1/4W
△ R257	HV756470	R. CAR. FP	4.7K Ω	1/4W
R267	HV755100	R. CAR. FP	100 Ω	1/4W
R278	HV755100	R. CAR. FP	100 Ω	1/4W
R289	HV755100	R. CAR. FP	100 Ω	1/4W
R300	HV755100	R. CAR. FP	100 Ω	1/4W
R311	HV755100	R. CAR. FP	100 Ω	1/4W
△ R384	HV753100	R. CAR. FP	1 Ω	1/4W
△ R385	HV753100	R. CAR. FP	1 Ω	1/4W
△ R401	HV753100	R. CAR. FP	1 Ω	1/4W
△ R402	HV753100	R. CAR. FP	1 Ω	1/4W
△ R403	V8070000	R. MTL. FLM	1 Ω	1W
△ R404	V8070000	R. MTL. FLM	1 Ω	1W
R405	V8070000	R. MTL. FLM	1 Ω	1W
R406	V8070000	R. MTL. FLM	1 Ω	1W
△ RY101	VU566700	RELAY	DG24D2-0S/M	
△ RY102	VK438300	RELAY	DH24D2-0T/M2	
△ RY103	VK438300	RELAY	DH24D2-0T/M2	
△ RY104	VK438300	RELAY	DH24D2-0T/M2	

* New Parts * 新規部品(マーク#の部品は、基板に含まれません)

Schm Ref.	PART NO.	Description		
ST101	V4040500	SCR. TERM	M3	
ST371	V4040500	SCR. TERM	M3	
ST381	V4040500	SCR. TERM	M3	
ST401	V4040500	SCR. TERM	M3	
△ SW381	V4104200	SW. SLIDE	SL13B-022-AMCS	
TE391	V8259500	TERM. SP	LQR2411-0001G	
TE392	V4470700	TERM. SP	6P	
TP381	VT969000	PIN. TEST	IRS-2049	
	V5995800	PLATE. GND		
	RD350000	R. CHP	0 Ω	1/16W
	RD353220	R. CHP	2.2 Ω	1/16W
	RD354470	R. CHP	47 Ω	1/16W
	RD354750	R. CHP	75 Ω	1/16W
	RD354820	R. CHP	82 Ω	1/16W
	RD355100	R. CHP	100 Ω	1/16W
	RD355220	R. CHP	220 Ω	1/16W
	RD355330	R. CHP	330 Ω	1/16W
	RD355390	R. CHP	390 Ω	1/16W
	RD355470	R. CHP	470 Ω	1/16W
	RD355680	R. CHP	680 Ω	1/16W
	RD356100	R. CHP	1K Ω	1/16W
	RD356120	R. CHP	1.2K Ω	1/16W
	RD356130	R. CHP	1.3K Ω	1/16W
	RD356150	R. CHP	1.5K Ω	1/16W
	RD356180	R. CHP	1.8K Ω	1/16W
	RD356220	R. CHP	2.2K Ω	1/16W
	RD356330	R. CHP	3.3K Ω	1/16W
	RD356360	R. CHP	3.6K Ω	1/16W
	RD356390	R. CHP	3.9K Ω	1/16W
	RD356470	R. CHP	4.7K Ω	1/16W
	RD356510	R. CHP	5.1K Ω	1/16W
	RD356680	R. CHP	6.8K Ω	1/16W
	RD356820	R. CHP	8.2K Ω	1/16W
	RD357100	R. CHP	10K Ω	1/16W
	RD357150	R. CHP	15K Ω	1/16W
	RD357180	R. CHP	18K Ω	1/16W
	RD357200	R. CHP	20K Ω	1/16W
	RD357220	R. CHP	22K Ω	1/16W
	RD357330	R. CHP	33K Ω	1/16W
	RD357470	R. CHP	47K Ω	1/16W
	RD358100	R. CHP	100K Ω	1/16W
	RD358220	R. CHP	220K Ω	1/16W
	RD358470	R. CHP	470K Ω	1/16W
	RD359100	R. CHP	1M Ω	1/16W

* New Parts * 新規部品(マーク#の部品は、基板に含まれません)

Parts List for Carbon Resistors

Value	1/4W Type Part No.	1/6W Type Part No.	Value	1/4W Type Part No.	1/6W Type Part No.
1.0 Ω	HJ35 3100	HF85 3100	10 kΩ	HF45 7100	HF45 7100
1.8 Ω	HJ35 3180	*	11 kΩ	HF45 7110	HF45 7110
2.2 Ω	HJ35 3220	HF85 3220	12 kΩ	HJ35 7120	HF85 7120
3.3 Ω	HJ35 3330	HF85 3330	13 kΩ	HF45 7130	HF45 7130
4.7 Ω	HJ35 3470	HF85 3470	15 kΩ	HF45 7150	HF45 7150
5.6 Ω	HJ35 3560	HF85 3560	18 kΩ	HF45 7180	HF45 7180
10 Ω	HF45 4100	HF45 4100	22 kΩ	HF45 7220	HF45 7220
15 Ω	HJ35 4150	HF85 4150	24 kΩ	HF45 7240	HF45 7240
22 Ω	HF45 4220	HF45 4220	27 kΩ	HJ35 7270	HF85 7270
27 Ω	HJ35 4270	HF85 4270	30 kΩ	HF45 7300	HF45 7300
33 Ω	HF45 4330	HF45 4330	33 kΩ	HF45 7330	HF45 7330
39 Ω	HJ35 4470	HF85 4390	36 kΩ	HF45 7360	HF45 7360
47 Ω	HF45 4470	HF45 4470	39 kΩ	HF45 7390	HF45 7390
56 Ω	HF45 4560	HF45 4560	47 kΩ	HF45 7470	HF45 7470
68 Ω	HF45 4680	HF45 4680	51 kΩ	HF45 7510	HF45 7510
75 Ω	HF45 4750	HF45 4750	56 kΩ	HF45 7560	HF45 7560
82 Ω	HF45 4820	HF45 4820	62 kΩ	HF45 7620	HF45 7620
91 Ω	HF45 4910	HF45 4910	68 kΩ	HF45 7680	HF45 7680
100 Ω	HF45 5100	HF45 5100	82 kΩ	HF45 7820	HF45 7820
110 Ω	HJ35 5110	HF85 5110	91 kΩ	HF45 7910	HF45 7910
120 Ω	HF45 5120	HF45 5120	100 kΩ	HF45 8100	HF45 8100
150 Ω	HF45 5150	HF45 5150	110 kΩ	HF45 8110	HF45 8110
160 Ω	HJ35 5160	*	120 kΩ	HF45 8120	HF45 8120
180 Ω	HF45 5180	HF45 5180	150 kΩ	HF45 8150	HF45 8150
200 Ω	HF45 5200	HF45 5200	180 kΩ	HF45 8180	HF45 8180
220 Ω	HF45 5220	HF45 5220	220 kΩ	HJ35 8220	HF85 8220
270 Ω	HF45 5270	HF45 5270	270 kΩ	HF45 8270	HF45 8270
330 Ω	HF45 5330	HF45 5330	300 kΩ	HF45 8300	HF45 8300
390 Ω	HF45 5390	HF45 5390	330 kΩ	HF45 8330	HF45 8330
430 Ω	HF45 5430	HF45 5430	390 kΩ	HJ35 8390	HF85 8390
470 Ω	HF45 5470	HF45 5470	470 kΩ	HF45 8470	HF45 8470
510 Ω	HF45 5510	HF45 5510	560 kΩ	HJ35 8560	HF85 8560
560 Ω	HF45 5560	HF45 5560	680 kΩ	HJ35 8680	HF85 8680
680 Ω	HF45 5680	HF45 5680	820 kΩ	HJ35 8820	HF85 8820
820 Ω	HF45 5820	HF45 5820	1.0 MΩ	HF45 9100	HF45 9100
910 Ω	HF45 5910	HF45 5910	1.2 MΩ	HJ35 9120	*
1.0 kΩ	HF45 6100	HF45 6100	1.5 MΩ	HJ35 9150	HF85 9150
1.2 kΩ	HF45 6120	HF45 6120	1.8 MΩ	HJ35 9180	HF85 9180
1.5 kΩ	HF45 6150	HF45 6150	2.2 MΩ	HJ35 9220	HF85 9220
1.8 kΩ	HF45 6180	HF45 6180	3.3 MΩ	HJ35 9330	HF85 9330
2.0 kΩ	HJ35 6200	HF85 6200	3.9 MΩ	HJ35 9390	*
2.2 kΩ	HF45 6220	HF45 6220	4.7 MΩ	HJ35 9470	HF85 9470
2.4 kΩ	HJ35 6240	HF85 6240			
2.7 kΩ	HF45 6270	HF45 6270			
3.0 kΩ	HF45 6300	HF45 6300			
3.3 kΩ	HF45 6330	HF45 6330			
3.6 kΩ	HJ35 6360	HF85 6360			
3.9 kΩ	HF45 6390	HF45 6390			
4.7 kΩ	HF45 6470	HF45 6470			
5.1 kΩ	HF45 6510	HF45 6510			
5.6 kΩ	HF45 6560	HF45 6560			
6.8 kΩ	HF45 6680	HF45 6680			
8.2 kΩ	HF45 6820	HF45 6820			
9.1 kΩ	HF45 6910	HF45 6910			

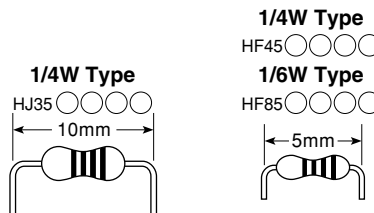

1/4W Type
HJ35 ○○○○
HF45 ○○○○

1/6W Type
HF85 ○○○○

* : Not available

1 ■ EXPLODED VIEW

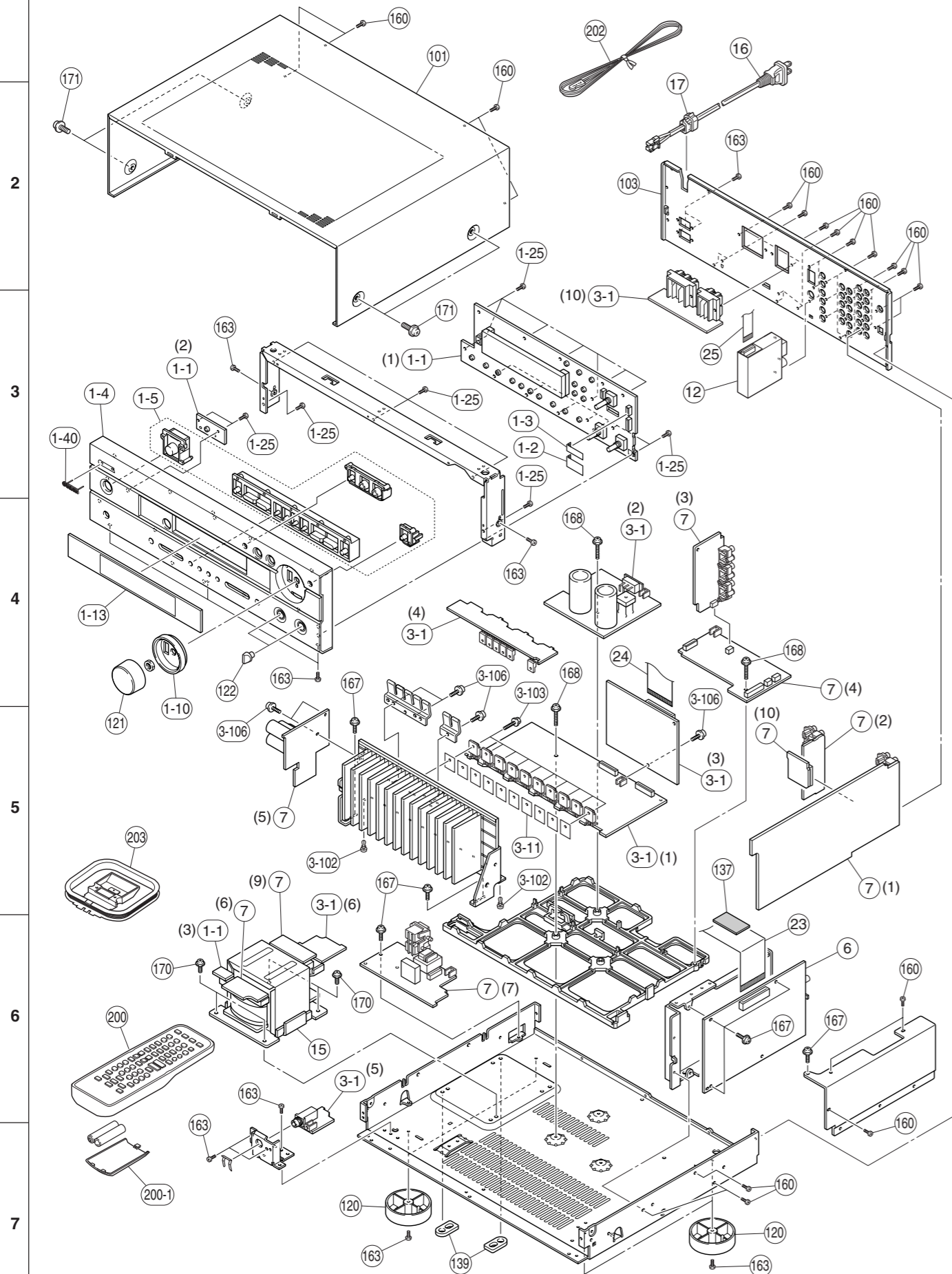

■ MECHANICAL PARTS

Schm Ref.	PART NO.	Description	Remarks
1-1	V8705200	P. C. B. ASS'Y	OPERATION
1-2	MF114180	FLEXIBLE FLAT CABLE	14P 180mm P=1.25
1-3	MF109140	FLEXIBLE FLAT CABLE	9P 140mm P=1.25
1-4	WA661300	FRONT PANEL	
1-5	V8315300	BUTTONCASE	
1-10	V8315800	ESCUTCHEON, VOL	
1-13	V8317500	SHEET, WINDOW	
1-25	EP630220	BIND HEAD P-TITE SCREW	3x8 MFZN2BL
1-40	V6034200	EMBLEM	
3-1	V8701100	P. C. B. ASS'Y	MAIN
3-11	VV849300	SHEET	19x24
3-102	VQ368600	PUSH RIVET	P3555-B
3-103	VK173200	SCREW, TRANSISTOR	3x15 SP MFC2
3-106	VT669300	PW HEAD B-TITE SCREW	3x8-8 MFC2
6	V8702000	P. C. B. ASS'Y	DSP
7	V8704300	P. C. B. ASS'Y	FUNCTION
12	V6782300	AM/FM TUNER	TFCE1U115A
15	X2372A00	POWER TRANSFORMER	
16	V2363800	POWER CABLE	2m
17	V2438700	CORD STOPPER	10P1
23	MF135100	FLEXIBLE FLAT CABLE	35P 100mm P=1.25
24	MF136140	FLEXIBLE FLAT CABLE	36P 140mm P=1.25
25	MF115120	FLEXIBLE FLAT CABLE	15P 120mm P=1.25
101	V8349000	TOP COVER	
103	WA661200	REAR PANEL	
120	VV544300	LEG	D60xH21
121	V6002200	KNOB D43	
122	V6001600	KNOB D15	
137	V3422200	DAMPER	
139	V7616600	DAMPER	
160	VN413300	BIND HEAD BONDING B-T. SCREW	3x8 MFZN2BL
163	EP600250	BIND HEAD B-TITE SCREW	3x8 MFZN2Y
167	VT669300	PW HEAD B-TITE SCREW	3x8-8 MFC2
168	VT669400	PW HEAD B-TITE SCREW	3x15-8 MFC2
170	21991500	PW HEAD S-TITE SCREW	4x8-10 MFC2BL
171	21991500	PW HEAD S-TITE SCREW	4x8-10 MFC2BL
		ACCESSORIES	
200	WA653400	REMOTE CONTROL	RAV301
200-1	AAX46580	BATTERY COVER	103RRC-244-01G
202	V6267000	INDOOR FM ANTENNA	1.4m 1pc
203	VR248500	AM LOOP ANTENNA	1.0m 1pc
		BATTERY	SUM-3N

* New Parts * 新規部品(マーク#の部品は、基板に含まれません)

REMOTE CONTROL RAV301

SCHEMATIC DIAGRAM

Function / Data Code List

KEY No.	Label	COMMON	YAMAHA signal (NEC format)										Library			
			AMP	(TV POWER)	(TV POWER)	(TV POWER)	(TV POWER)	(TV POWER)	(TV POWER)	(TV POWER)	(TV POWER)	(TV POWER)	Library	YAMAHA		
1	TV POWER	-	→	(TV POWER)	(TV POWER)	(TV POWER)	(TV POWER)	(TV POWER)	(TV POWER)	(TV POWER)	(TV POWER)	(TV POWER)	(TV POWER)			
2	AV POWER	-	→	Power	Power	Power	Power	VCR Power	Power	Power	Power	(device)				
3	STANDBY	O	7A-1E	STANDBY												
4	POWER ON	O	7A-1D	POWER ON												
8	SLEEP	O	7A-57	SLEEP												
20	CODE SET	O														
Library : All device codes can be entered into all modes.													default			
													Library	YAMAHA		
5	CD	O	7A-15	<INPUT key>	Output IR signal & change Device mode								CD	YAMAHA	Free	
6	MD/CD-R	O	7A-C9	<INPUT key>	Output IR signal & change Device mode								CD-R	YAMAHA	Free	
7	TUNER	O	7A-16	<INPUT key>	Output IR signal & change Device mode								TUNER	YAMAHA	Fix Code	
9	DVD	O	7A-C1	<INPUT key>	Output IR signal & change Device mode								DVD	YAMAHA (Philips)	Free	
10	D-TV/CBL	O	7A-54	<INPUT key>	Output IR signal & change Device mode								TV	Non	Fix Library (TV)	
11	VCR	O	7A-0F	<INPUT key>	Output IR signal & change Device mode								VCR	Non	Free	
12	V-AUX	O	7A-55	<INPUT key>	Output IR signal & change Device mode								V-AUX	Non	Free	
16	6CH INPUT	O	7A-87	6CH INPUT												
24	AMP	O	(-)	Change to AMP mode												
				KEY No.	6	6	7	9	10	11	12	24				
25	TV VOL +	-	→	(TV VOL +)	(TV VOL +)	(TV VOL +)	(TV VOL +)	(TV VOL +)	(TV VOL +)	(TV VOL +)	(TV VOL +)	(TV VOL +)				
26	TV VOL -	-	→	(TV VOL -)	(TV VOL -)	(TV VOL -)	(TV VOL -)	(TV VOL -)	(TV VOL -)	(TV VOL -)	(TV VOL -)	(TV VOL -)				
27	TV MUTE	-	→	(TV Mute)	(TV Mute)	(TV Mute)	(TV Mute)	(TV Mute)	(TV Mute)	(TV Mute)	(TV Mute)	(TV Mute)				
28	TV CH +	-	→	(TV CH +)	(TV CH +)	(TV CH +)	(TV CH +)	(TV CH +)	(TV CH +)	(TV CH +)	(TV CH +)	(TV CH +)				
29	TV CH -	-	→	(TV CH -)	(TV CH -)	(TV CH -)	(TV CH -)	(TV CH -)	(TV CH -)	(TV CH -)	(TV CH -)	(TV CH -)				
30	TV INPUT	-	→	(TV Input)	(TV Input)	(TV Input)	(TV Input)	(TV Input)	(TV Input)	(TV Input)	(TV Input)	(TV Input)				
31	VOL up	O	7A-1A	VOL UP												
32	VOL down	O	7A-1B	VOL DOWN												
33	MUTE	O	7A-1C	MUTE												
13	REC	-	→	Disk Skip	Disk Skip	-	Disk Skip	(VCR REC)	REC	REC	(device)					
14	PAUSE	-	→	Pause	Pause	-	Pause	VCR Pause	Pause	Pause	(device)					
15	AUDIO	-	→	-	-	-	AUDIO	-	-	-	(device)					
17	SKIP -	-	→	Skip -	Skip -	-	Skip -	-	-	-	(device)					
18	PLAY	-	→	Play	Play	-	Play	(VCR Play)	Play	Play	(device)					
19	SKIP +	-	→	Skip +	Skip +	-	Skip +	-	-	-	(device)					
21	REW (SEARCH -)	-	→	Rew	Rew	-	Rew	(VCR Rew)	Rew	Rew	(device)					
22	STOP	-	→	Stop	Stop	-	Stop	(VCR Stop)	Stop	Stop	(device)					
23	FF (SEARCH +)	-	→	FF	FF	-	FF	(VCR FF)	FF	FF	(device)					
46	TITLE	-	→	-	-	-	TITLE	-	-	-	LEVEL					
47	UP	-	→	-	-	PRESET +	UP	-	VCR CH +	VCR CH +	UP					
48	MENU	-	→	-	-	A/B/C/D/E	MENU	-	-	-	SET MENU					
49	LEFT	-	→	-	-	LEFT	-	-	-	-	LEFT					
50	SELECT	-	→	-	-	SELECT	-	-	-	-	-					
51	RIGHT	-	→	-	-	RIGHT	-	-	-	-	RIGHT					
52	RETURN	-	→	-	-	RETURN	-	-	-	-	TEST					
53	DOWN	-	→	-	-	PRESET -	DOWN	-	VCR CH -	VCR CH -	DOWN					
54	DISPLAY	-	→	DISPLAY	DISPLAY	-	DISLAY	DISLAY	-	-	-					
34	1	-	→	1	1	P1	1	1	1	1	PRG1					
35	2	-	→	2	2	P2	2	2	2	2	PRG2					
36	3	-	→	3	3	P3	3	3	3	3	PRG3					
37	4	-	→	4	4	P4	4	4	4	4	PRG4					
38	5	-	→	5	5	P5	5	5	5	5	PRG5					
39	6	-	→	6	6	P6	6	6	6	6	PRG6					
40	7	-	→	7	7	P7	7	7	7	7	PRG7					
41	8	-	→	8	8	P8	8	8	8	8	PRG8					
42	9	-	→	9	9	-	9	9	9	9	PRG9					
43	0	-	→	0/10	0/10	-	0	0/10	0/10	0/10	SELECT					
44	+10	-	→	+10	+10	-	+10	-/11	+10	+10	6.1/5.1					
45	ENTER	-	→	Index	Index	-	Title/Index	Enter/12	ENTER	ENTER	STEREO					
				Library	Free	Free	Fix code	Free	Fix Library	Free	Free	Fix code				

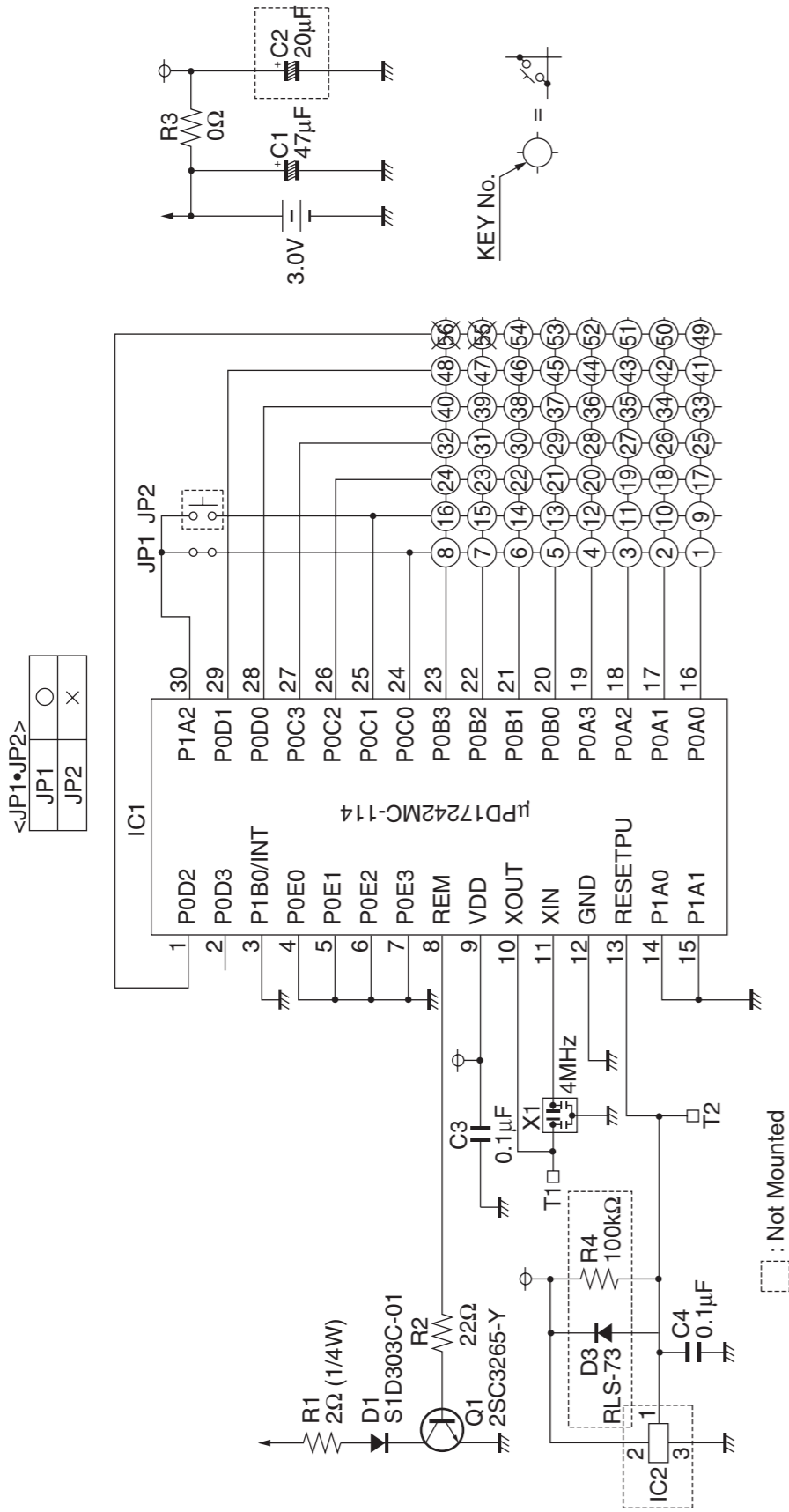

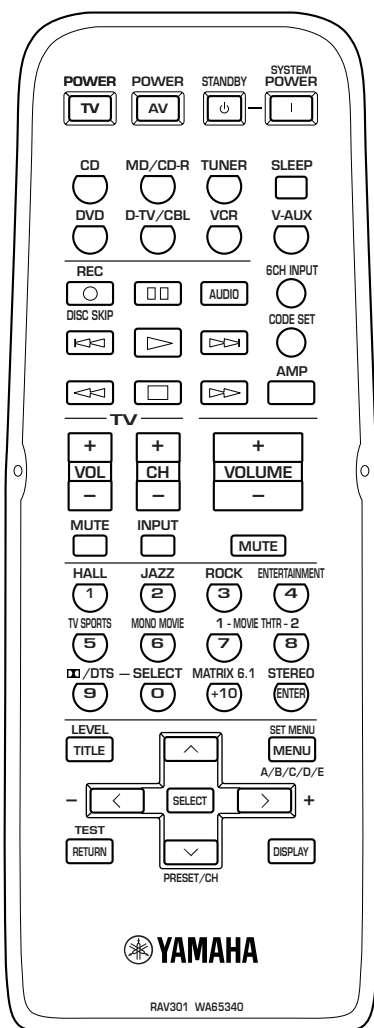

● Original Code List

KEY No.	CD		MD		CD-R		TUNER		DVD (P)		DVD (Y)		DVD (M)		DVD-R (P)		AMP	
	Label	CODE	Label	CODE	Label	CODE	Label	CODE	Label	CODE	Label	CODE	Label	CODE	Label	CODE	Label	CODE
2	POWER	-	POWER	-	POWER	7F-80	-	-	POWER	A5AA	POWER	7C-80	POWER	3D 8D	POWER	A5AA	(device)	-
13	Disc Skip	7A-4F	Rec	79-AF	Rec	-	-	-	Disc Skip	5556	Disc Skip	7C-8B	Disc Skip	-	Disc Skip	565A	(device)	-
14	Pause	7A-09	Pause	79-A9	Pause	7F-83	-	-	Pause	AA5A	Pause	7C-83	Pause	06 B6	Pause	AA5A	(device)	-
15	-	-	-	-	-	-	-	-	AUDIO	95A6	AUDIO	7C-AD	AUDIO	33 83	AUDIO	95A6	(device)	-
17	Skip -	7A-0B	Skip -	79-AB	Skip -	7F-86	-	-	Skip -	6A9A	Skip -	7C-B9	Skip -	49 F9	Skip -	6A9A	(device)	-
18	Play	7A-08	Play	79-A8	Play	7F-82	-	-	Play	A59A	Play	7C-82	Play	0A BA	Play	A59A	(device)	-
19	Skip +	7A-0A	Skip +	79-AE	Skip +	7F-87	-	-	Skip +	AA9A	Skip +	8C-BA	Skip +	4A FA	Skip +	AA9A	(device)	-
21	Rew	7A-0D	Rew	79-AC	Rew	7F-88	-	-	Rew	699A	Rew	7C-86	Rew	04 B4	Rew	699A	(device)	-
22	Stop	7A-09	Stop	79-AA	Stop	7F-84	-	-	Stop	6A5A	Stop	7C-85	Stop	00 B0	Stop	6A5A	(device)	-
23	FF	7A-0C	FF	79-AD	FF	7F-89	-	-	FF	A99A	FF	7C-97	FF	05 B5	FF	A99A	(device)	-
34	1	79-11	1	79-85	1	7F-91	P1	7A-E5	1	6AAA	1	7C-84	1	10 A0	1	6AAA	PRG1	7A-88
35	2	79-12	2	79-86	2	7F-92	P2	7A-E6	2	9AAA	2	7C-95	2	11 A1	2	9AAA	PRG2	7A-89
36	3	79-13	3	79-87	3	7F-93	P3	7A-E7	3	5AAA	3	7C-96	3	12 A2	3	5AAA	PRG3	7A-8A
37	4	79-14	4	79-88	4	7F-94	P4	7A-E8	4	A6AA	4	7C-97	4	13 A3	4	A6AA	PRG4	7A-8B
38	5	79-15	5	79-89	5	7F-95	P5	7A-E9	5	66AA	5	7C-98	5	14 A4	5	66AA	PRG5	7A-8C
39	6	79-16	6	79-8A	6	7F-96	P6	7A-EA	6	96AA	6	7C-99	6	15 A5	6	96AA	PRG6	7A-8D
40	7	79-17	7	79-8B	7	7F-97	P7	7A-EB	7	56AA	7	7C-9A	7	16 A6	7	56AA	PRG7	7A-8E
41	8	79-18	8	79-8C	8	7F-98	P8	7A-EC	8	A9AA	8	7C-9B	8	17 A7	8	A9AA	PRG8	7A-8F
42	9	79-19	9	79-8D	9	7F-99	-	-	9	69AA	9	7C-9C	9	18 A8	9	69AA	PRG9	7A-90
43	0/10	79-10	0	79-8E	0	7F-90	-	-	0	AAAA	0	7C-93	0	19 A9	0	AAAA	SELECT	7A-96
44	+10	79-1A	+10	79-8F	+10	7F-9A	-	-	+10	A956	+10	7C-9D	+10	89 39	+10	A956	6.1/5.1	7A-97
45	Index	79-0B	Index	-	Index	7F-8A	-	-	Title/Index	A9A5	Title/Index	7C-9E	Title/Index	-	Title/Index	A9A5	STEREO	7A-56
46	-	-	-	-	-	-	-	-	TITLE	6A56	TITLE	7C-B1	TITLE	9B 2B	TITLE	6A56	LEVEL	7A-86
47	-	-	-	-	-	-	PRESET +	7A-10	UP	A966	UP	7C-B4	UP	85 35	UP	A966	UP	7A-98
48	-	-	-	-	-	-	ABCDE	7A-12	MENU	A666	MENU	7C-B2	MENU	80 30	MENU	A666	SET	7A-9C
49	-	-	-	-	-	-	-	-	LEFT	9966	LEFT	7C-B5	LEFT	87 37	LEFT	9966	LEFT	7A-53
50	-	-	-	-	-	-	-	-	SELECT	A566	SELECT	7C-B8	SELECT	82 32	SELECT	A566	-	-
51	-	-	-	-	-	-	-	-	RIGHT	5966	RIGHT	7C-B6	RIGHT	88 38	RIGHT	5966	RIGHT	7A-52
52	-	-	-	-	-	-	-	-	Return	5AA9	Return	7C-B7	Return	81 31	Return	5AA9	TEST	7A-85
53	-	-	-	-	-	-	PRESET -	7A-11	DOWN	6966	DOWN	7C-B3	DOWN	86 36	DOWN	6966	DOWN	7A-99
54	Display	79-0A	Display	79-A5	Display	7F-9E	-	-	Display	55AA	Display	7C-A6	Display	92 22	Display	55AA	-	-

HTR-5635

HTR-5635

