

AV RECEIVER

RX-V357/HTR-5830

SERVICE MANUAL

IMPORTANT NOTICE

This manual has been provided for the use of authorized YAMAHA Retailers and their service personnel. It has been assumed that basic service procedures inherent to the industry, and more specifically YAMAHA Products, are already known and understood by the users, and have therefore not been restated.

WARNING: Failure to follow appropriate service and safety procedures when servicing this product may result in personal injury, destruction of expensive components, and failure of the product to perform as specified. For these reasons, we advise all YAMAHA product owners that any service required should be performed by an authorized YAMAHA Retailer or the appointed service representative.

IMPORTANT: The presentation or sale of this manual to any individual or firm does not constitute authorization, certification or recognition of any applicable technical capabilities, or establish a principle-agent relationship of any form.

The data provided is believed to be accurate and applicable to the unit(s) indicated on the cover. The research, engineering, and service departments of YAMAHA are continually striving to improve YAMAHA products. Modifications are, therefore, inevitable and specifications are subject to change without notice or obligation to retrofit. Should any discrepancy appear to exist, please contact the distributor's Service Division.

WARNING: Static discharges can destroy expensive components. Discharge any static electricity your body may have accumulated by grounding yourself to the ground buss in the unit (heavy gauge black wires connect to this buss).

IMPORTANT: Turn the unit OFF during disassembly and part replacement. Recheck all work before you apply power to the unit.

■ CONTENTS

TO SERVICE PERSONNEL	2~3	DISPLAY DATA	35~36
IMPEDANCE SELECTOR	3	IC DATA	37~42
FRONT PANELS	3~4	PRINTED CIRCUIT BOARD	43~51
REAR PANELS	5~9	PIN CONNECTION DIAGRAM	52
REMOTE CONTROL PANELS	9	BLOCK DIAGRAM	53
SPECIFICATIONS	10~13	SCHEMATIC DIAGRAM	54~58
INTERNAL VIEW	14	PARTS LIST	59~67
DISASSEMBLY PROCEDURES	14~16	REMOTE CONTROL	68~69
SELF DIAGNOSIS FUNCTION (DIAG)	17~33	Parts List for Carbon Resistors	69
CONFIRMATION OF IDLING CURRENT	34		



このサービスマニュアルは、エコマーク認定の再生紙を使用しています。
This Service Manual uses recycled paper.



■ TO SERVICE PERSONNEL

1. Critical Components Information

Components having special characteristics are marked  and must be replaced with parts having specifications equal to those originally installed.

2. Leakage Current Measurement (For 120V Models Only)

When service has been completed, it is imperative to verify that all exposed conductive surfaces are properly insulated from supply circuits.

- Meter impedance should be equivalent to 1500 ohms shunted by 0.15µF.

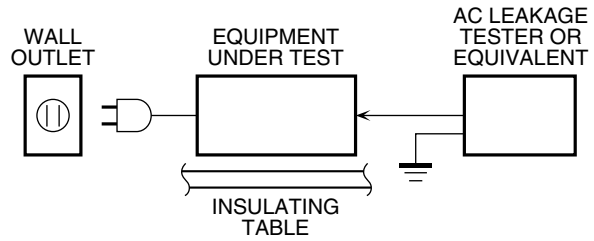

- Leakage current must not exceed 0.5mA.
- Be sure to test for leakage with the AC plug in both polarities.



“CAUTION”

“F371: FOR CONTINUED PROTECTION AGAINST RISK OF FIRE, REPLACE ONLY WITH SAME TYPE 6A, 125V FUSE.”

CAUTION

F371: REPLACE WITH SAME TYPE 6A, 125V FUSE.

ATTENTION

F371: UTILISER UN FUSIBLE DE RECHANGE DE MEME TYPE DE 6A, 125V.

WARNING: CHEMICAL CONTENT NOTICE!

The solder used in the production of this product contains LEAD. In addition, other electrical/electronic and/or plastic (where applicable) components may also contain traces of chemicals found by the California Health and Welfare Agency (and possibly other entities) to cause cancer and/or birth defects or other reproductive harm.

DO NOT PLACE SOLDER, ELECTRICAL/ELECTRONIC OR PLASTIC COMPONENTS IN YOUR MOUTH FOR ANY REASON WHATSOEVER!

Avoid prolonged, unprotected contact between solder and your skin! When soldering, do not inhale solder fumes or expose eyes to solder/flux vapor!

If you come in contact with solder or components located inside the enclosure of this product, wash your hands before handling food.

About Lead Free Solder

The P.C.B.s installed in this unit are soldered using the following solder.

	Side A	Side B
DSP P.C.B.	Lead Free Solder	Lead Free Solder
FUNCTION P.C.B.	–	Lead Free Solder
MAIN P.C.B.	–	Lead Free Solder

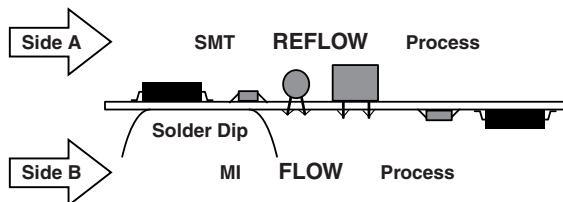

Among some types of lead free solder currently available, it is recommended to use one of the following types for the repair work.

- Sn + Ag + Cu (tin + silver + copper)
- Sn + Cu (tin + copper)
- Sn + Zn + Bi (tin + zinc + bismuth)

Caution:

1. As the melting point temperature of the lead free solder is about 30°C to 40°C (50°F to 70°F) higher than that of the lead solder, be sure to use a soldering iron suitable to each solder.
2. If lead solder must be used, be sure to remove lead free solder from each terminal section of the parts to be replaced and from the area around it completely before soldering, or make sure that the lead free solder and lead solder melt together fully.

■ IMPEDANCE SELECTOR

U, C models

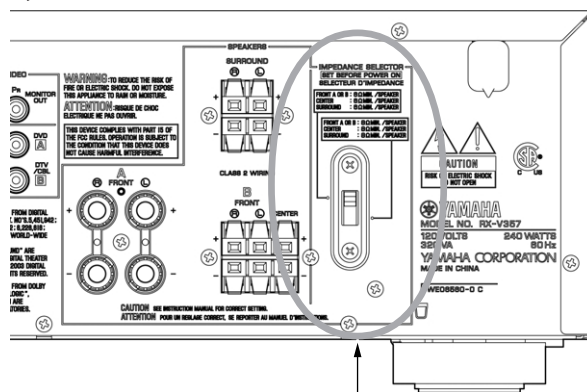

IMPEDANCE SELECTOR

WARNING:
Do not change the IMPEDANCE SELECTOR switch setting while the power to this unit is on, otherwise this unit may be damaged.

■ FRONT PANELS

RX-V357 (C, R, T, K, A, L models)

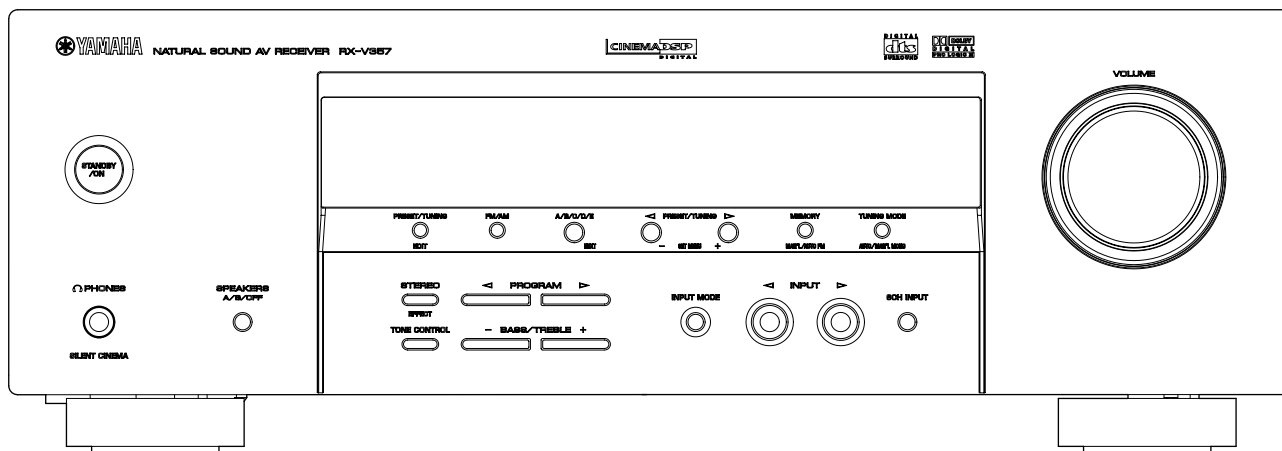

RX-V357/HTR-5830

RX-V357 (B, G, E models)

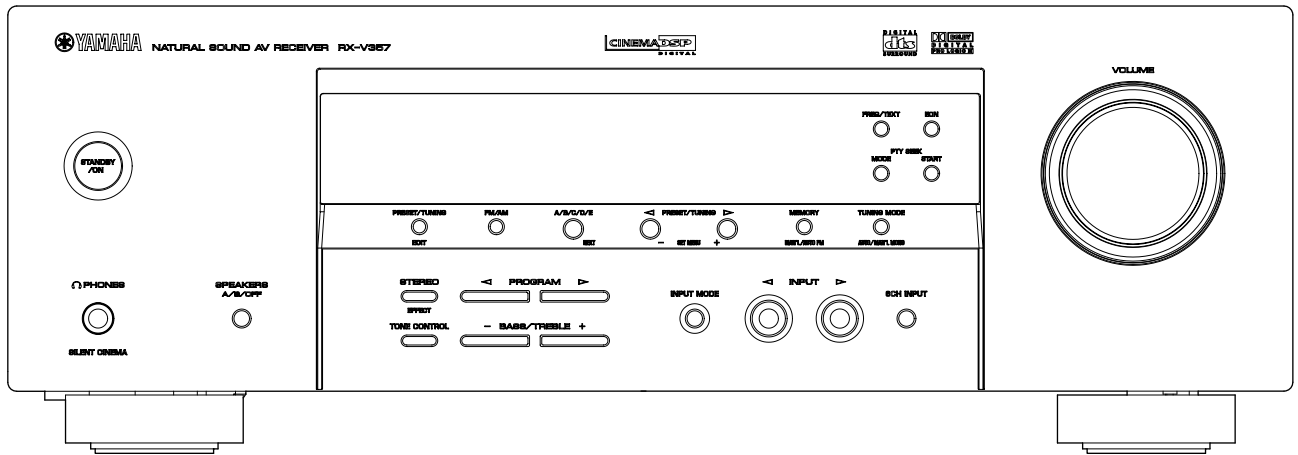

HTR-5830 (U, C, R, T, K, A models)

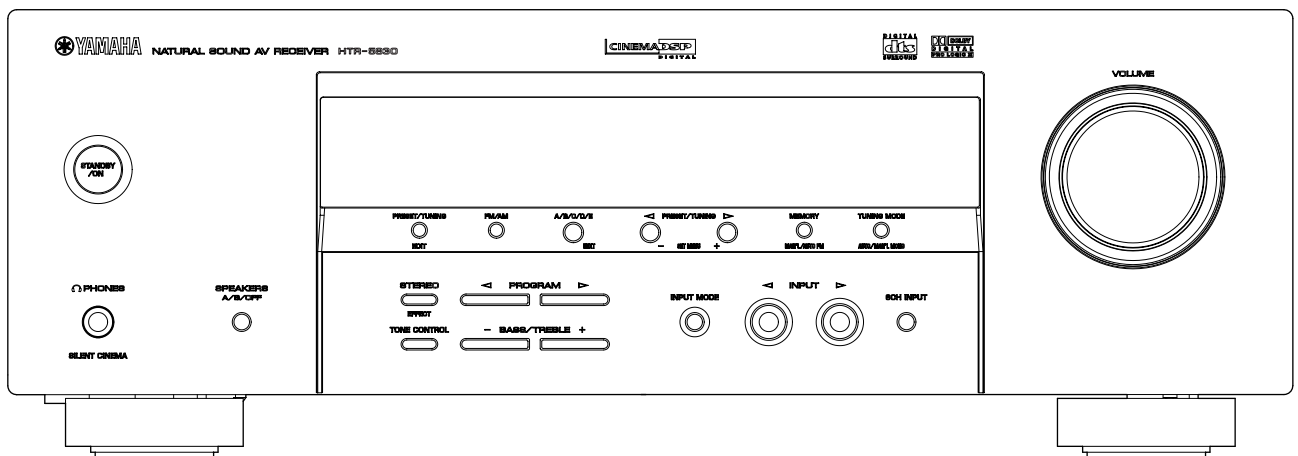

HTR-5830 (B, G, E models)

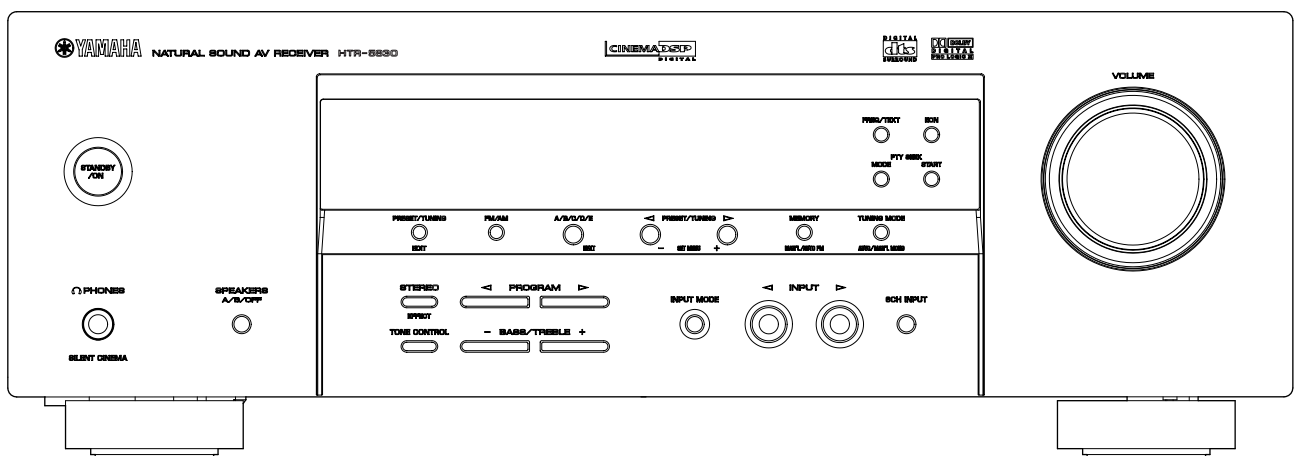

RX-V357/HTR-5830

REAR PANELS

RX-V357 (C model)

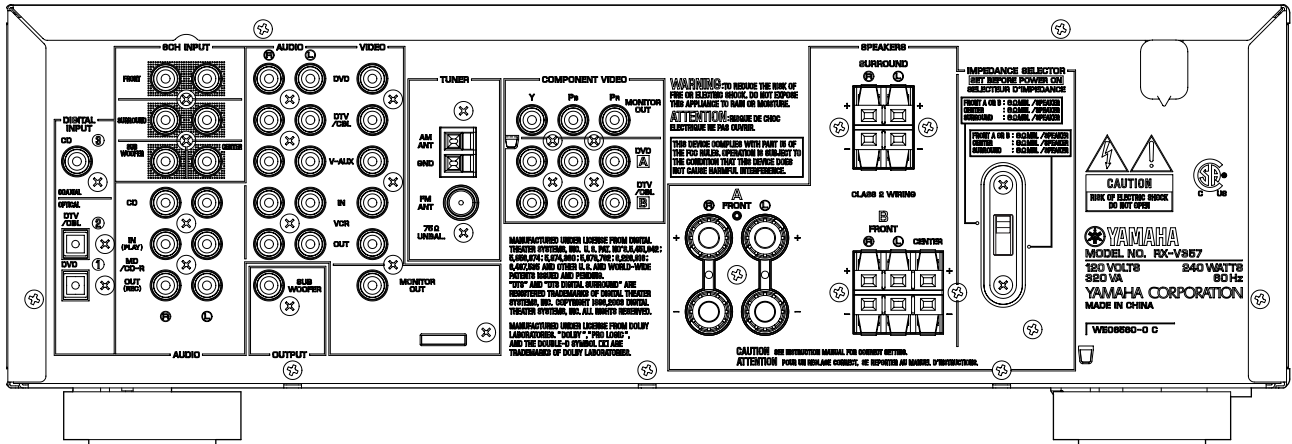

RX-V357 (R model)

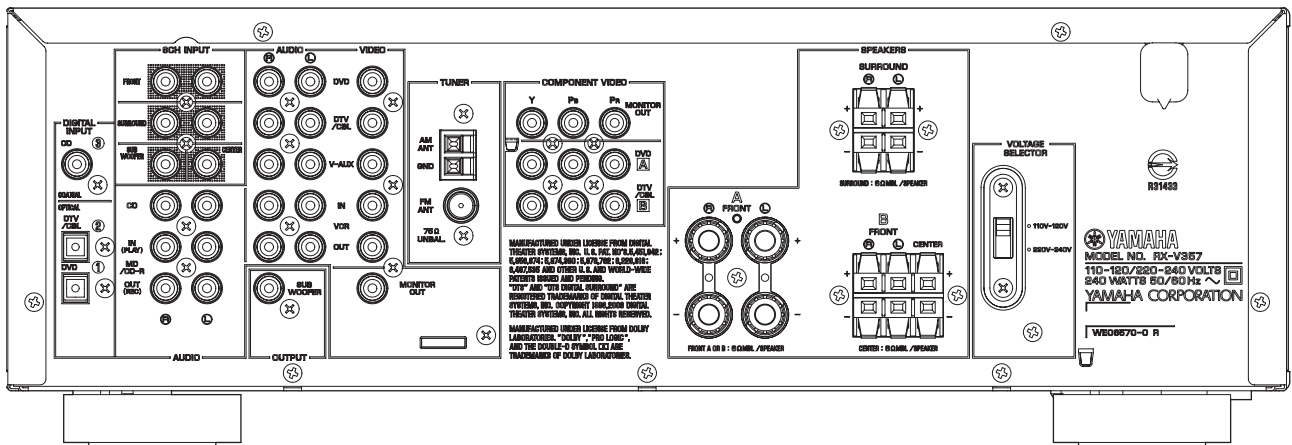

RX-V357 (T model)

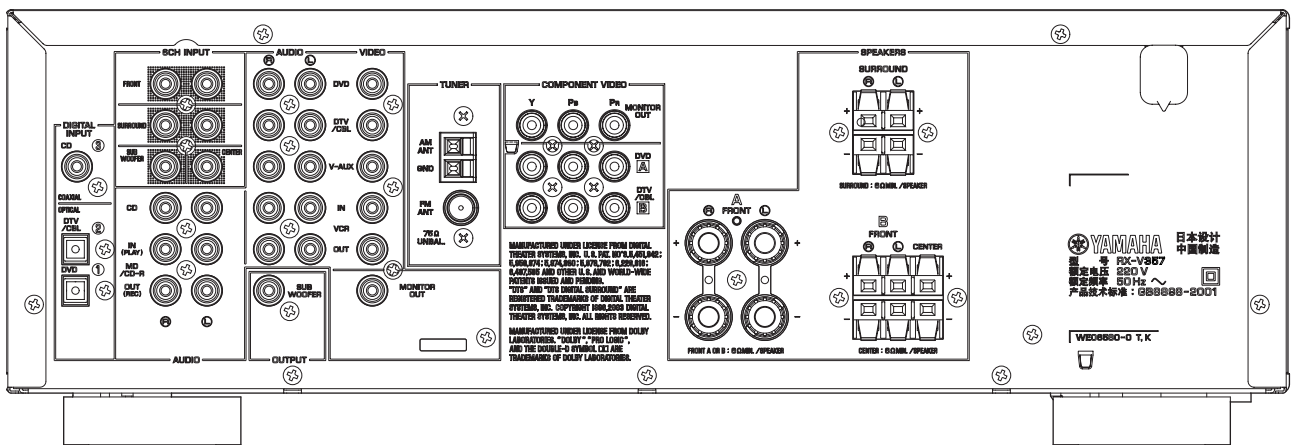

RX-V357/HTR-5830

RX-V357 (L model)

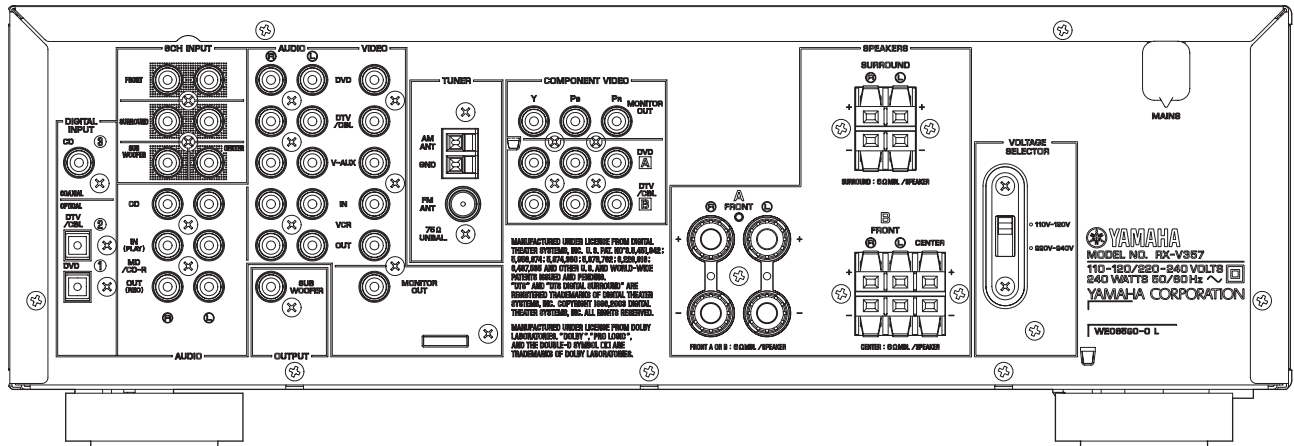

HTR-5830 (U, C models)

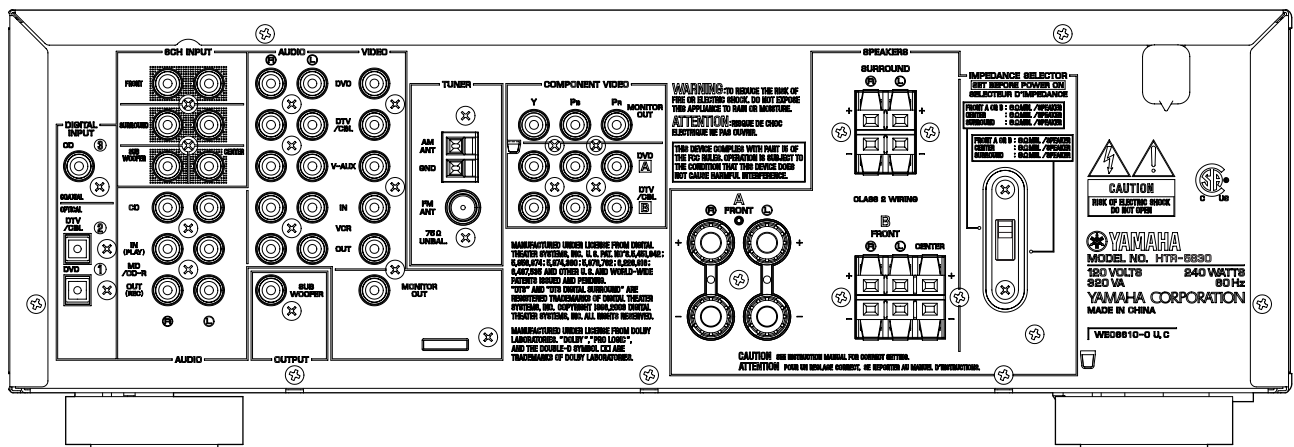

HTR-5830 (R model)

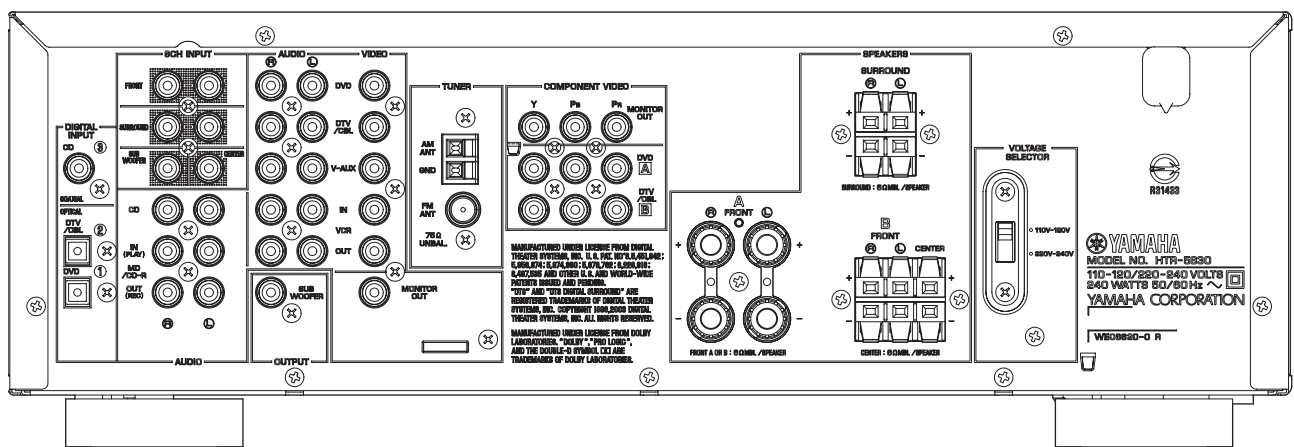

RX-V357/HTR-5830

HTR-5830 (B, G, E models)

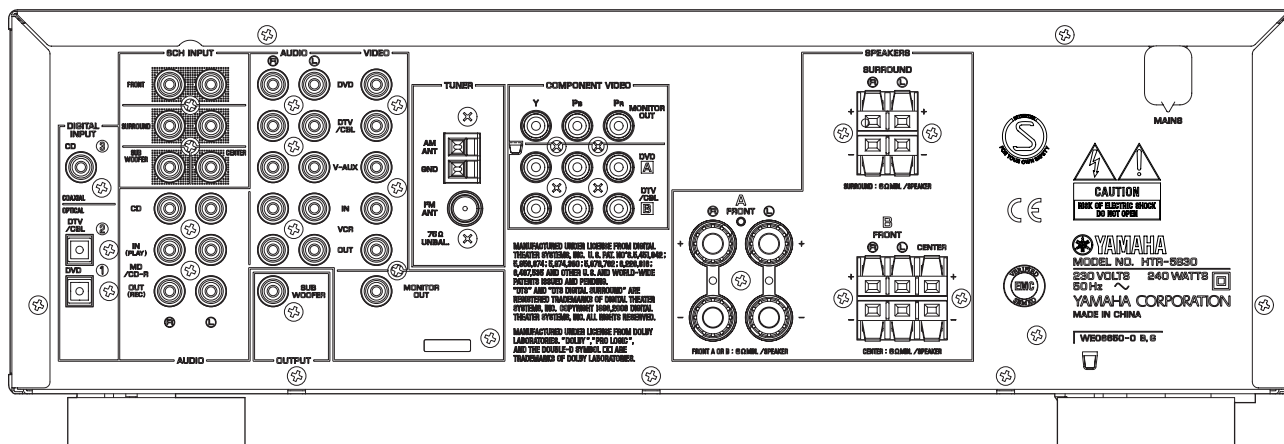

■ REMOTE CONTROL PANELS

RX-V357 (C, R, T, K, A, L models)
HTR-5830 (U, C, R, T, K, A models)

RX-V357 (B, G, E models)
HTR-5830 (B, G, E models)

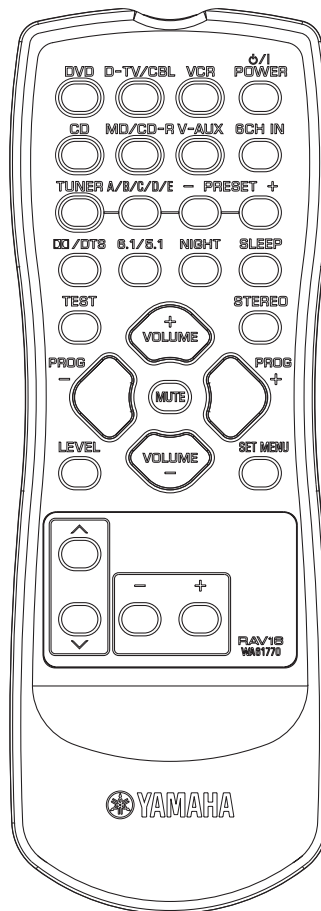
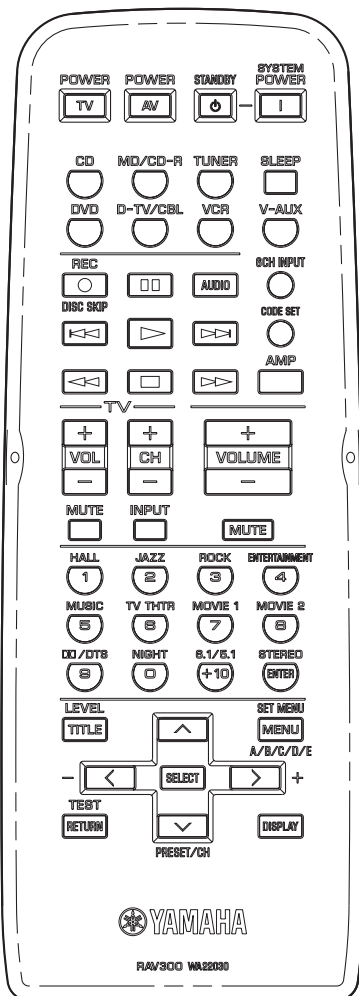

RX-V357/HTR-5830

■ SPECIFICATIONS

■ Audio Section

Minimum RMS Output Power (Power Amp. Section)

(1 kHz, 0.9 % THD, 8 ohms)

FRONT L/R
U, C models 110 W + 110 W

CENTER
U, C models 110 W

SURROUND L/R
U, C models 110 W + 110 W

(1 kHz, 0.9 % THD, 6 ohms)

FRONT L/R
U, C models 110 W + 110 W
R, T, K, A, B, G, E, L models 100 W + 100 W

CENTER
U, C models 110 W
R, T, K, A, B, G, E, L models 100 W

SURROUND L/R
U, C models 110 W + 110 W
R, T, K, A, B, G, E, L models 100 W + 100 W

Maximum Power [R, T, K, L models]

(EIAJ, 1 kHz, 10 % THD, 6 ohms)

FRONT L/R 110 W + 110 W

CENTER 110 W

SURROUND L/R 110 W + 110 W

DIN Standard Output Power Per Channel

[B, G, E, L models]

(1 kHz, 0.7 % THD, 4 ohms)

FRONT L/R 105 W + 105 W

CENTER 105 W

SURROUND L/R 105 W + 105 W

IEC Power [B, G, E, L models]

1 kHz, 0.1 % THD, 6 ohms 90 W + 90 W

Dynamic Power Per Channel (IHF)

U, C models (8/6/4/2 ohms) 120/140/160/180 W

R, T, K, A, B, G, L, E models

(6/4/2 ohms) 105/135/165 W

Dynamic Headroom [U, C models]

6 ohms 0.38 dB

Input Sensitivity / Input Impedance

CD, etc. 200 mV / 47 k-ohms

EXT. DECODER

FRONT L/R, CENTER, SURROUND L/R,
SUB WOOFER 200 mV / 47 k-ohms

Maximum Input Signal Level

(1 kHz, 0.5 % THD, Effect On)

CD, etc. 2.0 V or more

Output Level / Output Impedance

REC OUT 200 mV / 1.2 k-ohms

SUB WOOFER (FRONT SP: Small) .. 4 V / 1.2 k-ohms

Headphone Jack Rated Output / Impedance

CD, etc. (1 kHz, 200 mV, 8 ohms) 0.4 V / 470 ohms

Frequency Response

CD, etc. to FRONT L/R (10 Hz to 100 kHz) 0 / -3.0 dB

Total Harmonic Distortion

(1 kHz, 50 W, 6 ohms)

CD, etc. (Effect Off) to
FRONT L/R SP OUT 0.06 % or less

Signal to Noise Ratio (IHF-A network)

CD, etc. (Input shorted, EFFECT OFF) to
FRONT L/R SP OUT
250mV 100 dB or more

Residual Noise (IHF-A network)

FRONT L/R SP OUT 150 μ V or less

Channel Separation

(Vol -14 dB, Effect Off)

CD, etc. (Input 5.1 k-ohms shorted, 1 kHz / 10 kHz)
..... 60 dB or more / 45 dB or more

Tone Control Characteristics

BASS

Boost/Cut \pm 10 dB (100Hz)

TREBLE

Boost/Cut \pm 10 dB (20 kHz)

Filter Characteristics

FRONT, SURROUND L/R

SP Small (H.P.F.) 90 Hz / 12 dB oct.

SUBWOOFER (L.P.F.) 90 Hz / 18 dB oct.

■ Video Section

Video Signal Type

U, C, R, K models NTSC

T, A, B, G, E, L models PAL

Video Signal Level

..... 1 Vp-p / 75 ohms

Component Signal Level

..... 1 Vp-p / 75 ohms

Maximum Input Level

..... 1.5 Vp-p or more

Signal to Noise Ratio

..... 50 dB or more

Monitor Out Frequency Response

Video Signal Level 5 Hz to 10 MHz, -3 dB

Component Signal Level 5 Hz to 60 MHz, -3 dB

■ FM Section

Tuning Range

U, C models 87.5 to 107.9 MHz

R, L models 87.5 to 108.0 / 87.50 to 108.00 MHz

T, K, A, B, G, E models 87.50 to 108.00 MHz

50dB Quieting Sensitivity (IHF)

(1 kHz, 100 % Mod.)

Mono 2.8 μ V (20.2 dBf)

Signal to Noise Ratio (IHF)

Mono / Stereo 73 dB / 70 dB

Harmonic Distortion

(1 kHz)

Mono/Stereo 0.5 % / 0.5 %

• Set Menu Table

The value inside of [] shows initial setting.

Category	No.	MAIN MENU	SUB MENU	VALUE [INITIAL]	
BASIC	1	SETUP	ROOM : S >M L	S/[M]/L	
			SUBWOOFER YES	[YES]/NONE	
			SPEAKERS 5spk	2/3/4/[5]	
			>SET CANCEL	[SET]/CANCEL	
			Check : Test Tone		
			Check OK? Yes	[Yes]/No	
	2	SP LEVEL	FL ---- ----- R	[Center] ±10step	
			C ---- -----	[Center] ±10step	
			SL ---- -----	[Center] ±10step	
			SR ---- -----	[Center] ±10step	
SWFR -----			[0dB] -20step		
SOUND	1	SPEAKER SET	1A CENTER SML	LRG/[SML]/NON	
			1B FRONT LRG	[LRG]/SML	
			1C SURR LR SML	LRG/[SML]/NON	
			1D BASS BOTH	SWFR/FRNT/[BOTH]	
	2	SP DISTANCE	UNIT	meters(m)/feet(ft)	
			FRONT L/R 3.00m	0.3 to 24m [3.00m]/0.1m step	
			CENTER 3.00m	0.3 to 24m [3.00m]/0.1m step (Effective distance difference 1.5m)	
			SURR LR 3.00m	0.3 to 24m [3.00m]/0.1m step	
	3	LFE LEVEL	SP LFE 0	-20dB to [0dB]/1dB step	
			HP LFE 0	-20dB to [0dB]/1dB step	
	4	DYNAMIC RANGE	SP D.R > MAX	MIN/STD/[MAX]	
			HP D.R > MAX	MIN/STD/[MAX]	
	5	CENTER GEQ	100Hz - - 0	-6dB to +6dB [0dB]/1dB step	
			300Hz - - 0	-6dB to +6dB [0dB]/1dB step	
			1kHz - - 0	-6dB to +6dB [0dB]/1dB step	
			3kHz - - 0	-6dB to +6dB [0dB]/1dB step	
			10kHz - - 0	-6dB to +6dB [0dB]/1dB step	
	6	HP TONE CONTROL	HP BASS 0	-6dB to +3dB [0dB]/1dB step	
			HP TRBL 0	-6dB to +3dB [0dB]/1dB step	
	INPUT	1	I/O ASSIGN	1A (A) DVD	[DVD], MD/CD-R, CD, VCR, V-AUX, DTV/CBL
				1A (B) DTV/CBL	CD, VCR, V-AUX, [DTV/CBL], DVD, MD/CD-R
1B (1) DVD				CD, VCR, V-AUX, DTV/CBL, [DVD], MD/CD-R	
1B (2) DTV/CBL				CD, VCR, V-AUX, [DTV/CBL], DVD, MD/CD-R	
1C (3) CD				[CD], VCR, V-AUX, DTV/CBL, DVD, MD/CD-R	
2		INPUT MODE	2 >AUTO LAST	[AUTO]/LAST	
OPTION	1	DISPLAY SET	1 DIMMER 0	-4 to [0]/1 step	
	2	MEMORY GUARD	2 M GUARD OFF	[OFF]/ON	
	3	AUDIO MUTE	3 MUTE: MUTE	[MUTE]/-50dB/-20dB	

• The variable range of the parameter (Min/Max/Step)

		Unit
DSP LEVEL	-6/+3/1	dB
DELAY	1/99/1	ms

5ch Stereo Parameter		Unit
CT LEVEL	0/100/1	%
SL LEVEL	0/100/1	%
SR LEVEL	0/100/1	%

Pro Logic II Music Parameter		Unit
PANORAMA	OFF/ON	
DIMENSIONS	-3/+3/1	
CT WIDTH	0/7/1	

- **Resetting the factory presets**

To reset all of parameters, do the following procedure. This procedure completely resets ALL parameters, including the SET MENU, level, assign, and tuner presets.

Note: Only the tuner's frequency step is not reset in this procedure. (R, L models)

1 With the main unit in standby mode, hold down "STEREO (EFFECT)" key and press "STANDBY/ON" key. Then PRESET is displayed.

2 Press "STEREO (EFFECT)" key to select the desired setting.

RESET To reset the main unit to its factory presets.
CANCEL To cancel without making any changes.

3 Press "STANDBY/ON" key.

If you selected RESET, the main unit is reset its factory presets and switches to standby mode.

If you selected CANCEL, the main unit switches to standby mode and nothing is reset.

Note: The setting you made are reflected the next time this main unit's power is turned on.

- **Changing tuner's FREQUENCY STEP (R, L models only)**

To change the tuner's frequency step, do the following procedure.

1 With the main unit in standby mode, hold down "STEREO (EFFECT)" key and press "STANDBY/ON" key. Then PRESET is displayed.

2 Press "PROGRAM <" or "PROGRAM >" key to select TUNER.

3 Press "STEREO (EFFECT)" key to select the desired setting.

AM10/FM100 or AM9/FM50

4 Press "STANDBY/ON" key.

The main unit changes to standby mode.

Note: The setting you made are reflected the next time this main unit's power is turned on.

INTERNAL VIEW

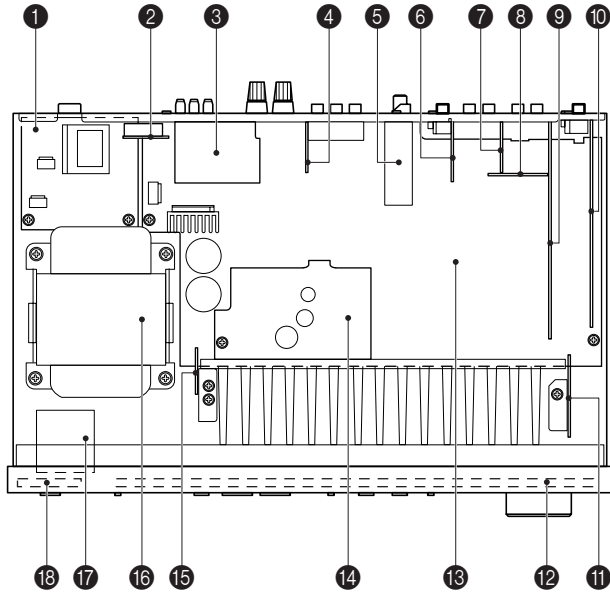

- ① MAIN (2) P.C.B.
- ② MAIN (6) P.C.B. (U, C models)
FUNCTION (7) P.C.B. (R, L models)
- ③ MAIN (4) P.C.B.
- ④ MAIN (5) P.C.B.
- ⑤ Tuner
- ⑥ MAIN (3) P.C.B.
- ⑦ FUNCTION (3) P.C.B.
- ⑧ FUNCTION (6) P.C.B.
- ⑨ FUNCTION (1) P.C.B.
- ⑩ DSP P.C.B.
- ⑪ FUNCTION (9) P.C.B.
- ⑫ FUNCTION (2) P.C.B.
- ⑬ MAIN (1) P.C.B.
- ⑭ FUNCTION (4) P.C.B.
- ⑮ FUNCTION (8) P.C.B.
- ⑯ Power Transformer
- ⑰ FUNCTION (10) P.C.B.
- ⑱ FUNCTION (5) P.C.B.

DISASSEMBLY PROCEDURES

(Remove parts in the order as numbered.)
Disconnect the power cable from the AC outlet.

1. Removal of Top Cover

- a. Remove 5 screws (①) and 4 screws (②). (Fig. 1)
- b. Slide the Top Cover rearward to remove it. (Fig. 1)

2. Removal of Front Panel Unit

- a. Loosen the harness fixture fixing the cable.
- b. Remove CB431, CB653 and CB804. (Fig. 1)
- c. Remove 6 screws (③). (Fig. 1)
- d. Release a hook on the right side of the Front Panel Unit, then remove the Front Panel Unit forward. (Fig. 1)

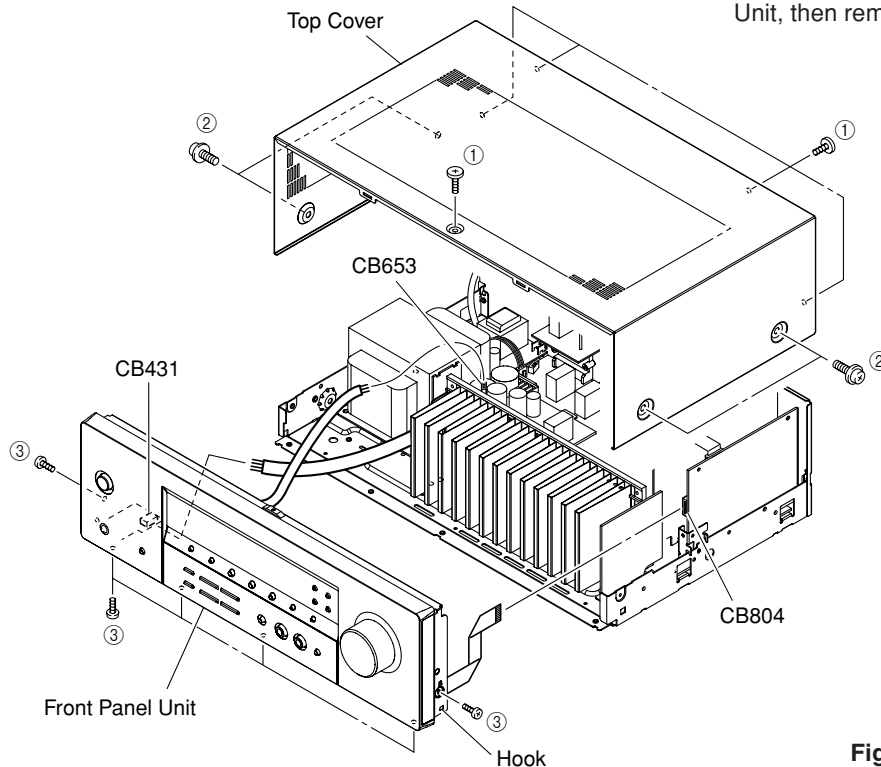

Fig. 1

3. Removal of MAIN (3) ~ MAIN (5), FUNCTION (3), FUNCTION (6) P.C.B.s and Tuner

- a. Remove CB242, CB391 and CB701. (Fig. 2)
- b. Remove 9 screws (④). (Fig. 3)
- c. Remove MAIN (3), MAIN (5) P.C.B.s. and the Tuner. (Fig. 2)
- d. Remove 18 screws (⑤). (Fig. 3)
- e. Remove 3 screws (⑥). (Fig. 3)
- f. Remove Cord Stopper. (Fig. 2)
- g. Remove Rear Panel. (Fig. 2)
- h. Remove MAIN (4), FUNCTION (3) and FUNCTION (6) P.C.B.s. (Fig. 2)

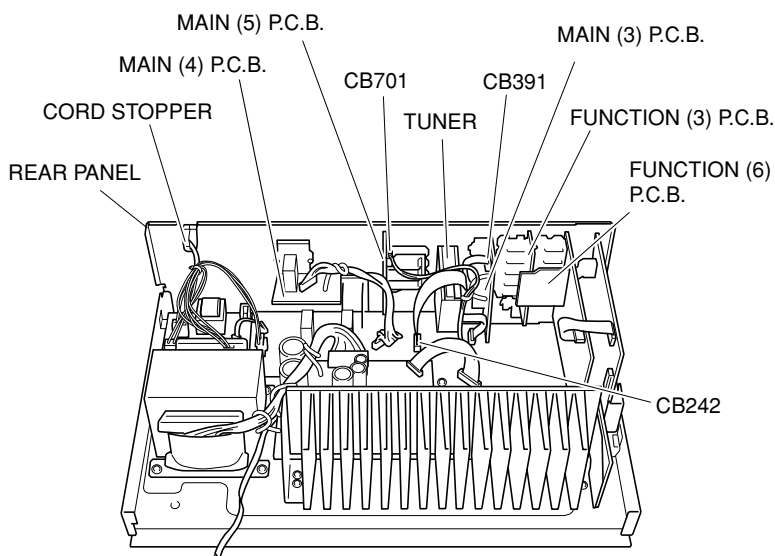

Fig. 2

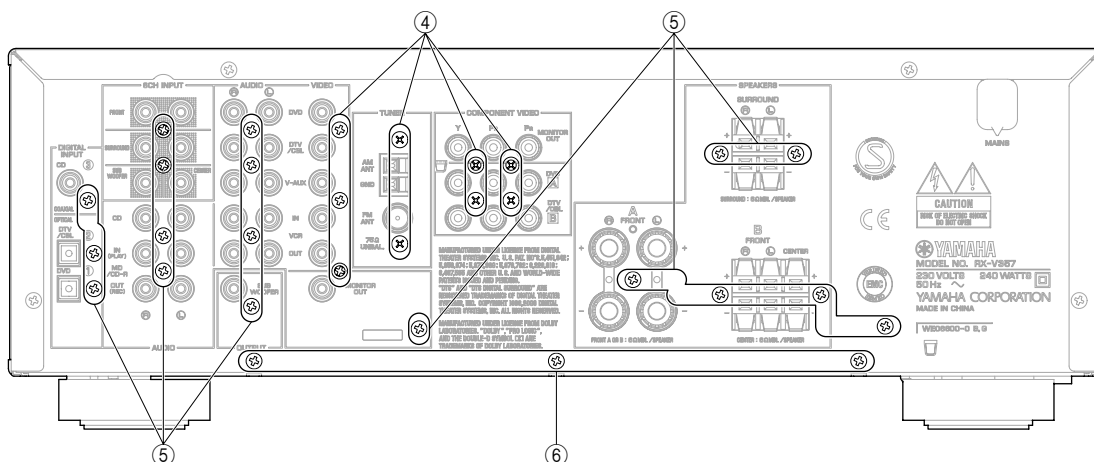

Fig. 3

4. Removal of DSP P.C.B.

- a. Remove 1 screw (⑦). (Fig. 4)
- b. Remove CB803. (Fig. 4)
- c. Remove the DSP P.C.B. with the Support/DSP. (Fig. 4)

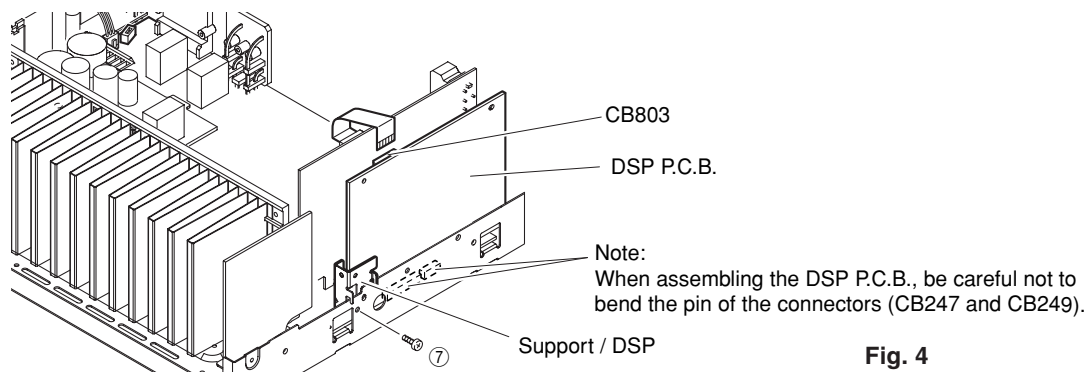

Fig. 4

5. Removal of MAIN (1), FUNCTION (1), FUNCTION (8) and FUNCTION (9) P.C.B.s

- a. Remove 1 screw (⑧). (Fig. 5)
- b. Remove FUNCTION (1) P.C.B. (Fig. 5)
- c. Remove CB103, CB104 and CB652. (Fig. 5)
- d. Remove 3 screws (⑨). (Fig. 5)
- e. Remove 4 screws (⑩). (Fig. 5)
- f. Remove MAIN (1), FUNCTION (4), FUNCTION (8) and FUNCTION (9) P.C.B.s. (Fig. 5)

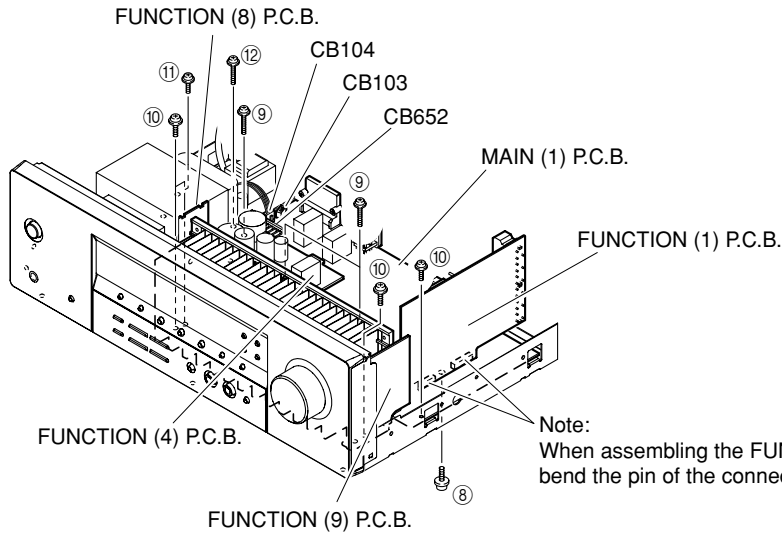

Fig. 5

When checking the P.C.B.:

- a. Remove the Top Cover.
- b. Remove 3 screws (⑥). (Fig. 3)
- c. Remove 1 screw (⑦). (Fig. 4)
- d. Remove 3 screws (⑨). (Fig. 5)
- e. Remove 4 screws (⑩). (Fig. 5)
- f. Remove 1 screw (⑪). (Fig. 5)
- g. Remove 1 screw (⑫). (Fig. 5)
- h. Place the P.C.B. upright. (Fig. A and B)
- i. Be sure to connect the ground of MAIN (1) P.C.B. (G103, G104, G241) and FUNCTION (4) P.C.B. (G651) to the chassis with a jumper wire or the like.

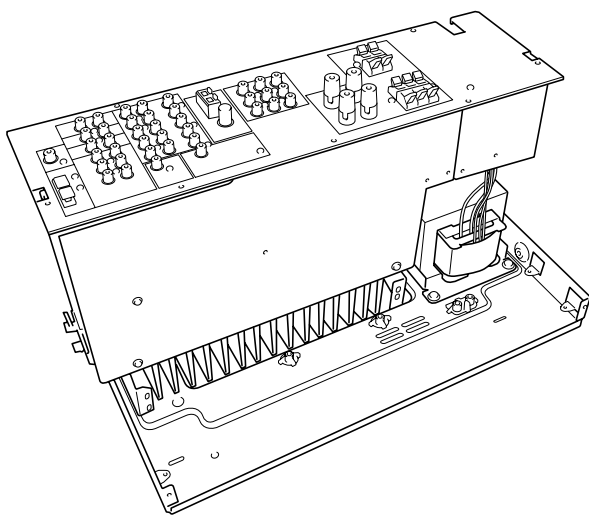

Fig. A

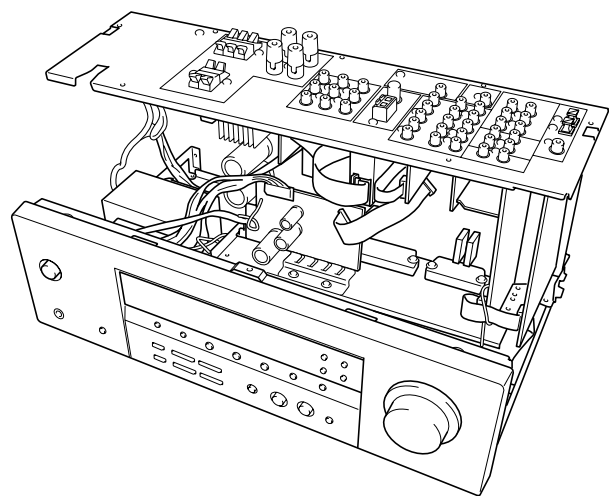

Fig. B

■ SELF DIAGNOSIS FUNCTION (DIAG)

There are 15 DIAG menu items, each of which has sub-menu items.

Listed in the table below are menu items and sub-menu items.

Note that not all menu items listed will apply to the models covered in this service manual.

No	DIAG menu	sub-menu
1	DSP THROUGH 1. ANALOG BYPASS	1. ANALOG BYPASS
		2. YSS 0dB
		3. YSS Presence 0dB
		4. YSS FULL BIT
		5. YSS FULL BIT P
2	RAM THROUGH 2. RAM 0dB	RAM 0dB
3	DOLBY PRO LOGIC 3. PRO LOGIC I	1. PRO LOGIC I
		2. PRO LOGIC II
		3. Neo:6 (Not applied to these models)
4	SPEAKERS SET 4. FRNT: SML 0dB	1. FRONT: SMALL 0dB
		2. CENTER: NONE
		3. LFE/BASS: FRONT
		4. PRESENCE MIX: 5ch
		5. SURROUND B power (Not applied to these models)
		6. Tone Control Flat
		7. Tone Control +10dB
		8. Tone Control -10dB
5	HP Test 5. FRONT12dB	1. FRONT 12 dB
		2. FRONT 15 dB
6	OTHER INPUT 6. EXTERNAL DEC	EXTERNAL DECODER
7	DISPLAY CHECK 7. VFD CHECK	1. VFD CHECK (Initial display)
		2. VFD DISP OFF (All segments OFF)
		3. VFD DISP ALL (All segments ON 100%)
		4. VFD DIMMER (All segments ON 50%)
		5. CHECKED PATTERN (ON in lattice)
8	MANUAL TEST 8. TEST ALL	1. TEST ALL
		2. TEST FRONT L
		3. TEST CENTER
		4. TEST FRONT R
		5. TEST SURROUND R
		6. TEST SURROUND C (Not applied to these models)
		7. TEST SURROUND L
		8. TEST LFE
9	FACTORY PRESET 9. PRESET INHI	1. PRESET INHIBITED (memory initialization inhibited)
		2. PRESET RESERVED (memory initialized)
10	AD DATA CHECK /FAN TEST DC: 23%PS: 16%	1. DC/PS (protection indication)
		2. THM/Fan
		3. REC-OUT (Not applied to these models)
		4. IMP SW/POWER LIMIT
		5. K0/K1 (panel key)
		6. FAN DRIVE TEST: HIGH (Not applied to these models)
		7. FAN DRIVE TEST: MID (Not applied to these models)
		8. FAN DRIVE TEST: LOW (Not applied to these models)

No	DIAG menu	sub-menu
11	IF STATUS Isi: 220000200000	1. INSIDE STATUS 1 (5 Byte)
		2. INSIDE STATUS 2 (3 Byte)
		3. CHANNEL STATUS 1 (5 Byte)
		4. CHANNEL STATUS 2 (5 Byte)
		5. CHANNEL STATUS 3 (5 Byte)
		6. CHANNEL STATUS 4 (5 Byte)
		7. CHANNEL STATUS 5 (4 Byte)
		8. BSI (YSS) 1 (5 Byte)
		9. BSI (YSS) 2 (5 Byte)
		10. BSI (YSS) 3 (5 Byte)
		11. BSI (YSS) 4 (4 Byte)
		12. BSI (CS) 1 (5 Byte)
		13. BSI (CS) 2 (5 Byte)
		14. BSI (CS) 3 (5 Byte)
		15. BSI (CS) 4 (5 Byte)
		16. BSI (CS) 5 (1 Byte)
		17. YSS938-1 (5 Byte)
		18. YSS938-2 (5 Byte)
		19. YSS938-3 (4 Byte)
		20. SECOND DECODER (3 Byte)
		21. Mute Trigger (5 Byte)
12	DSP RAM CHECK YSS BUS: NoEr	1. YSS938 BUS CHECK 2. PLD/SRAM BUS CHECK
13	SD DL CODE RDV: XXXXXXXX	1. ROM DATA Version
		2. TOC Area 0
		3. TOC Area 1
		4. TOC Area 2
		5. TOC Area 3
		6. TOC Area 4
		7. TOC Area 5
		8. Sum check Area 0
		9. Sum check Area 1
		10. Sum check Area 2
		11. Sum check Area 3
		12. Sum check Area 4
		13. Sum check Area 5
14	SOFT SWITCH 14. SW :PCB	1. SW MODE: PCB/SOFT
		2. MODEL SETTING: V357/V357T
		3. TUNER DESTINATION: UC/AKGTE/RL
		4. TUNER: EXIST/NOT
		5. RDS: EXIST/NOT
		6. ZONE 2: EXIST/NOT
		7. VIDEO FORMAT (Not applied to these models)
15	ROM VERSION/CHECK SUM/ PORT VER. XXXXX	1. VERSION
		2. CHECK SUM ALL/PROGRAM
		3. PORT
		4. AAC PORT

• Starting DIAG

Press the “STANDBY/ON” key while simultaneously pressing those two keys of the main unit as indicated in the figure below.

Keys of main unit

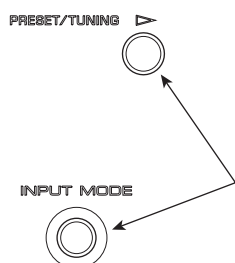

Turn on the power while pressing these keys.

• Starting DIAG in the protection cancel mode

If the protection function works and causes hindrance to trouble diagnosis, cancel the protection function as described below, and it will be possible to enter the DIAG mode. (The protection functions other than the excess current detect function will be disabled.)

Press the “STANDBY/ON” key while simultaneously pressing those two keys indicated in the figure above. At this time, keep pressing those two keys for 3 seconds or longer.

In this mode, the “SLEEP” segment of the FL display of the main unit flashes to indicate that the mode is DIAG mode with the protection functions disabled.

CAUTION!

Using this product with the protection function disabled may cause damage to itself. Use special care for this point when using this mode.

• Canceling DIAG

[1] Before canceling DIAG, execute setting for PRESET of DIAG menu No.9 (Memory initialization inhibited or Memory initialized).

* In order to keep the user memory stored, be sure to select PRESET INHIBITED (Memory initialization inhibited).

[2] Turn off the power by pressing the “STANDBY/ON” key of the main unit.

• Display provided when DIAG started

The FL display of the main unit displays the protection function history data and the version (1 alphabet) and the DIAG menu [sub-menu (ANALOG BYPASS) of DIAG menu No.1 DSP THROUGH] a few seconds later.

When there is no history of protection function:

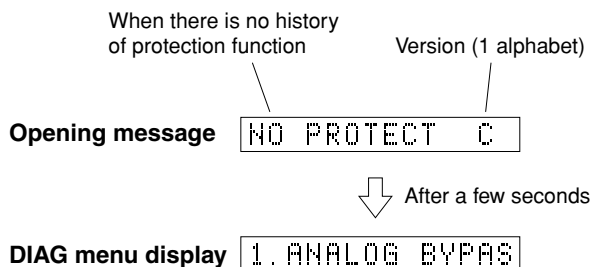

When there is a history of protection function:

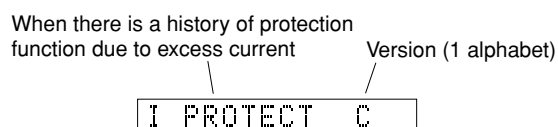

Cause: An excessive current flowed through the power amplifier.

Supplementary information: As the current through the power transistor is detected, the abnormal channel can be identified by checking the current detect transistor.

Turning on the power without correcting the abnormality will cause the protection function to work immediately and the power supply will instantly be shut off.

Note)

- Applying the power to a unit without correcting the abnormality can be dangerous and cause additional circuit damage.
- The output transistors in each amplifier channel should be checked for damage before applying any power.
- The amplifier current should be monitored by measuring across the emitter resistors for each channel.

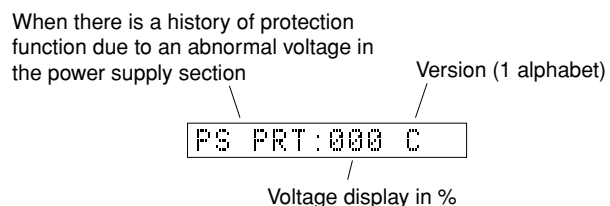

Cause: The voltage in the power supply section is abnormal.

Supplementary information: The abnormal voltage is displayed in % based on 5V as 100%.

Turning on the power without correcting the abnormality will cause the protection function to work 1 second later and the power supply will be shut off.

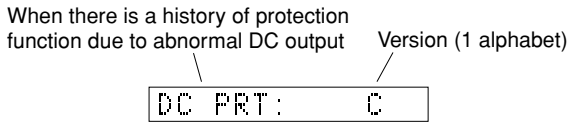

Cause: DC output of the power amplifier is abnormal.

Turning on the power without correcting the abnormality will cause the protection function to work 3 seconds later and the power supply will be shut off.

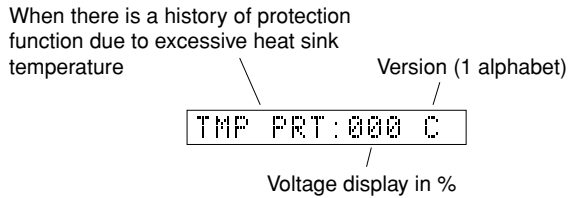

Cause: The temperature of the heat sink is excessive.

Supplementary information: The abnormal voltage is displayed in % based on 5V as 500%.

Turning on the power without correcting the abnormality will cause the protection function to work 1 second later and the power supply will be shut off.

- * Additional causes of protection can be due to loose connections, associated components, CPU, etc.
- * For the protection voltage value, refer to DIAG menu No.10 described later.

• History of protection function

When the protection function has worked, its history is stored in memory with a backup. Even if no abnormality is noted while servicing the unit, an abnormality which has occurred previously can be defined as long as the backup data has been stored. The history of the protection function is cleared when DIAG is cancelled by selecting PRESET RESERVED (Memory initialized) of DIAG menu No.9 or when the backup data is erased.

• Display during menu operation

During the DIAG operation, the function at work is indicated on the FL indicator. The contents displayed during the function operation are described in the later section on details of functions.

• Operation procedure of DIAG menu and SUB-MENU

There are 15 MENU items, each of which has some SUB-MENU items.

DIAG menu selection

Main unit: Select the menu using ▷ (Forward) and ◁ (Reverse) PROGRAM keys.

SUB-MENU selection

Main unit: Select the sub-menu using - and + BASS/TREBLE keys.

Keys of main unit

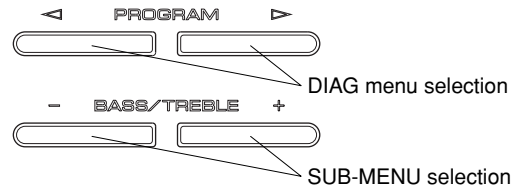

• Functions in DIAG mode

In addition to the DIAG menu items, functions as listed below are available.

- Input selection, 6CH input
- Center/Surround/Sub-woofer level adjustment
- Muting
- Power on/off
- Master volume
- * Functions related to the tuner and the set menu are not available.
- * It is possible to confirm Menu No.11 IF STATUS while keeping the signal process (operation status) of each DIAG menu by using the input mode key of the main unit.

• Initial settings used to start DIAG

The following initial settings are used when starting DIAG. When DIAG is canceled, these settings are restored to those before starting DIAG.

- Master volume: -24dB
- Input: DVD (6CH INPUT OFF)
- Effect level: 0dB
- Audio mute: OFF
- Speaker setting: LARGE / BASS OUT = BOTH
- DIAG menu: DSP THROUGH (1. ANALOG BYPASS)

• **Details of DIAG menu**

With full-bit output specified in some modes, it is possible to execute 0dBFS output without including the head margin in each channel.

1. DSP THROUGH

Main DSP of YSS938 is selected for Front L/R output.

ANALOG BYPASS

- The signal for L/R is output as it is without passing through the DSP section.

1. ANALOG BYPASS

Reference data

INPUT: DVD ANALOG

SWFR: 50Hz, Others: 1kHz

Input level	Volume	SPEAKER OUTPUT (1kHz)			SUBWOOFER OUTPUT (50Hz)
		FRONT L/R	CENTER	SL/SR	
Both ch, -20 dBm	+6.0 dB	+11.5 dBm	- ∞	- ∞	- ∞

YSS 0dB

- The signal is output including the head margin.
Head margin:
FRONT L/R: 0dBFS, Center: -6dBFS,
SL/SR: -12dBFS,
SWFR: Add L/R signal at -20dBFS.

1. YSS 0dB

Reference data

INPUT: DVD ANALOG

SWFR: 50Hz, Others: 1kHz

Input level	Volume	SPEAKER OUTPUT (1kHz)			SUBWOOFER OUTPUT (50Hz)
		FRONT L/R	CENTER	SL/SR	
Both ch, -20 dBm	+6.0 dB	+11.5 dBm	+11.5 dBm	+11.5 dBm	-0.5 dBm

YSS Presence 0dB

- The Presence CH signal including the head margin is output at the Front CH.
Head margin:
FRONT L/R: -6dBFS, Center: 0dBFS,
SL/SR: 0dBFS, SWFR: Add L/R signal at 0dBFS.

1. YSS Presence 0dB

Reference data

INPUT: DVD ANALOG

SWFR: 50Hz, Others: 1kHz

Input level	Volume	SPEAKER OUTPUT (1kHz)			SUBWOOFER OUTPUT (50Hz)
		FRONT L/R	CENTER	SL/SR	
Both ch, -20 dBm	+6.0 dB	- ∞	- ∞	- ∞	- ∞

YSS FULL BIT

- The signal is output in digital full bit without including the head margin. The SWFR signal is output but not in digital full bit.

1. YSS FULL BIT

Reference data

INPUT: DVD ANALOG

SWFR: 50Hz, Others: 1kHz

Input level	Volume	SPEAKER OUTPUT (1kHz)			SUBWOOFER OUTPUT (50Hz)
		FRONT L/R	CENTER	SL/SR	
Both ch, -20 dBm	+6.0 dB	+11.5 dBm	+11.5 dBm	+11.5 dBm	-0.5 dBm

DSP THROUGH
YSS (Analog)

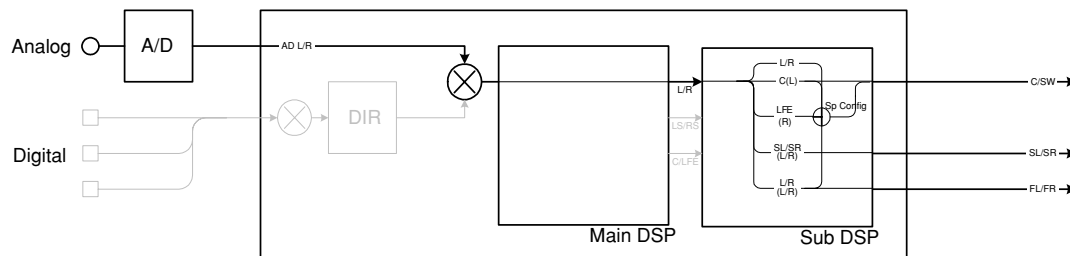

(Shaded items not used in this example)

YSS FULL BIT P

- The Presence CH signal is output in digital full bit at the Front CH.

1. FULL BIT F

Reference data

INPUT: DVD ANALOG

SWFR: 50Hz, Others: 1kHz

Input level	Volume	SPEAKER OUTPUT (1kHz)			SUBWOOFER OUTPUT (50Hz)
		FRONT L/R	CENTER	SL/SR	
Both ch, -20 dBm	+6.0 dB	-∞	-∞	-∞	-∞

DSP THROUGH
YSS (PCM)

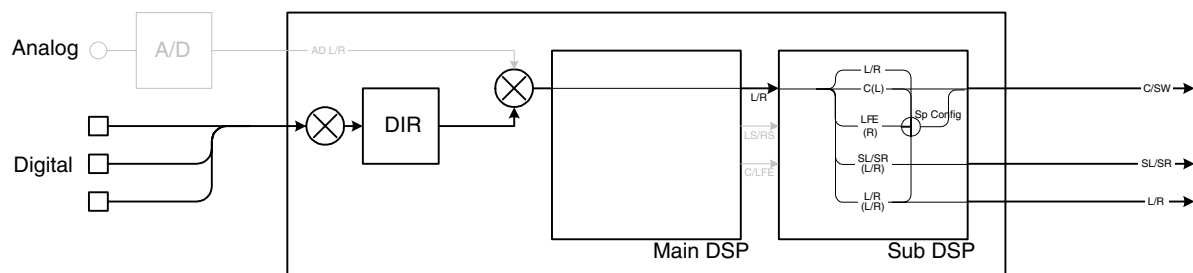

(Shaded items not used in this example)

DSP THROUGH
YSS (DD / dts [EX / ES off])

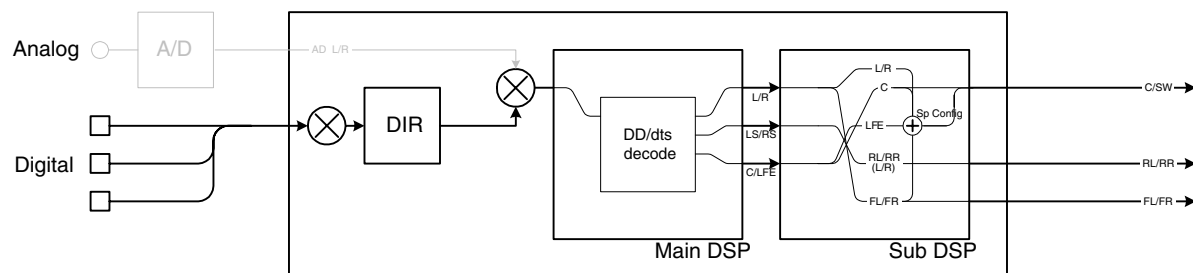

(Shaded items not used in this example)

RX-V357/HTR-5830

2. RAM THROUGH

This function is for YSS938 only.

Only the CT signal is output through the Sub DSP – DRAM.

RAM 0dB

2. RAM 0dB

Reference data

INPUT: DVD ANALOG

SWFR: 50Hz, Others: 1kHz

Input level	Volume	SPEAKER OUTPUT (1kHz)			SUBWOOFER OUTPUT (50Hz)
		FRONT L/R	CENTER	SL/SR	
Both ch, -20 dBm	+6.0 dB	- ∞	+5.5 dBm	- ∞	- ∞

RAM THROUGH
(Auto)

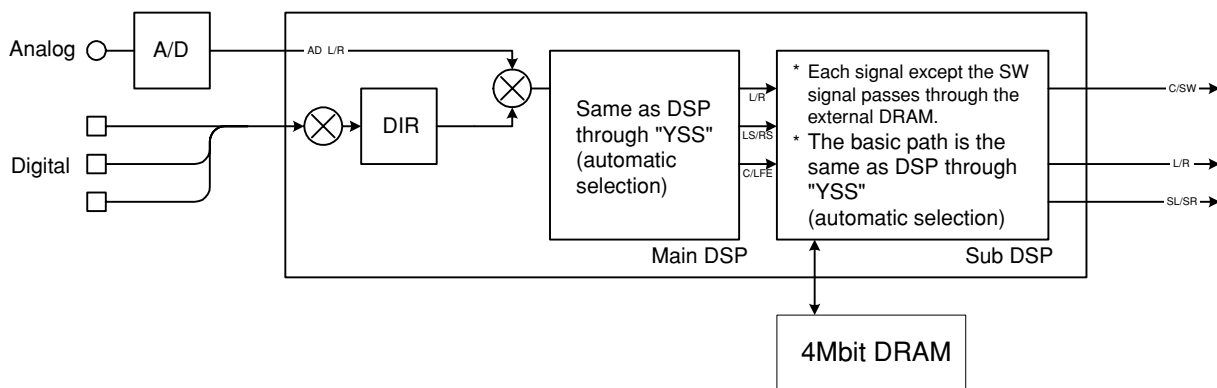

(Shaded items not used in this example)

3. PRO LOGIC

PRO LOGIC I

3. PRO LOGIC I

Reference data
 INPUT: DVD ANALOG
 SWFR: 50Hz, Others: 1kHz

Input level	Volume	SPEAKER OUTPUT (1kHz)			SUBWOOFER OUTPUT (50Hz)
		FRONT L/R	CENTER	SL/SR	
Each ch, -20 dBm	+6.0 dB	+11.5 dBm	- ∞	- ∞	-10.5 dBm
Both ch, -20 dBm	+6.0 dB	- ∞	+14.5 dBm	- ∞	- ∞

PRO LOGIC II

3. PRO LOGIC II

Reference data
 INPUT: DVD ANALOG
 SWFR: 50Hz, Others: 1kHz

Input level	Volume	SPEAKER OUTPUT (1kHz)			SUBWOOFER OUTPUT (50Hz)
		FRONT L/R	CENTER	SL/SR	
Each ch, -20 dBm	+6.0 dB	+11.5 dBm	- ∞	- ∞	-10.5 dBm
Both ch, -20 dBm	+6.0 dB	- ∞	+14.5 dBm	- ∞	- ∞

The L/C/R/SL/SR signals undergo the Pro-Logic processing and C/SL/SR signals are output through Sub DSP-DRAM. The Main DSP is selected for FRONT L/R output.

Using the sub-menu, it is possible to select PRO LOGIC I, II (Movie). The Auto Input Balance function is always off. When the Dolby Digital Multi input is used, the function is the same as in the Dolby Digital Normal mode. The LFE signal is not output when decoding in the PRO LOGIC I, II mode.

Dolby Pro Logic (Auto)

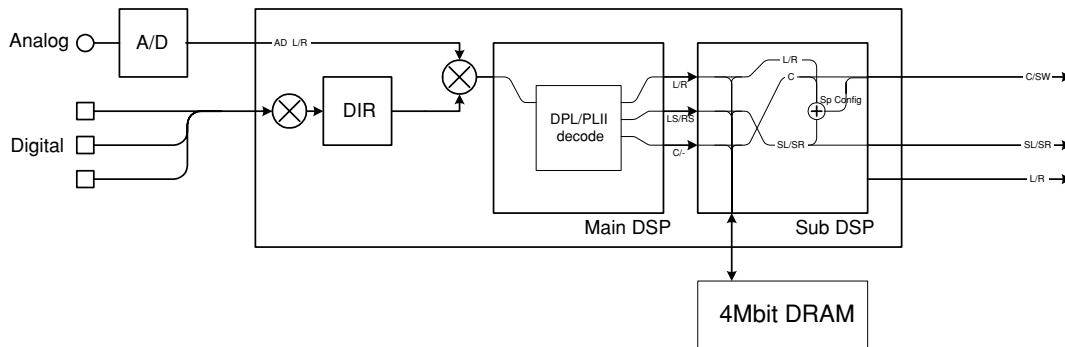

(Shaded items not used in this example)

Neo:6
 (Not applied to these models.)

3. Neo:6

4. SPEAKERS SET

The input signal is automatically identified and switched in the priority order of dts → DOLBY DIGITAL → AAC → PCM AUDIO → Analog (A/D) according to the signal detection.

The signals output from the DSP block are the same as 1. DSP THROUGH: YSS 0dB.

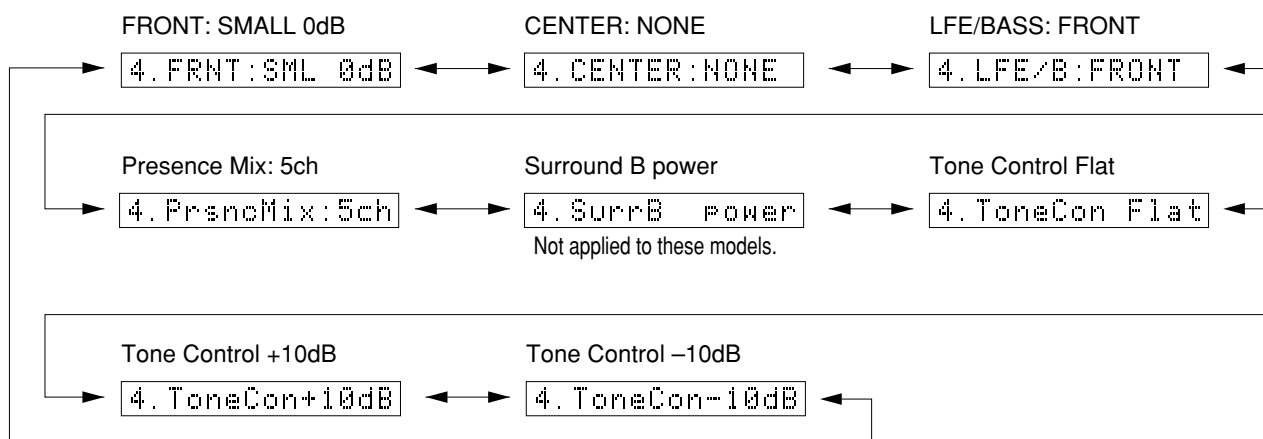

The analog switch settings for each sub-menu are as shown in the table below.

Sub-menu		CENTER SP	SURROUND SP	FRONT SP	FRONT LEVEL	LFE/BASS
1	FRONT: SMALL 0dB	LARGE	LARGE	SMALL	0dB	SWFR
2	CENTER: NONE	NONE	LARGE	LARGE	0dB	BOTH
3	LFE/BASS: FRONT	SMALL	SMALL	LARGE	0dB	FRONT
4	Presence Mix: 5CH	LARGE	LARGE	LARGE	0dB	BOTH

- LARGE:** This mode is used with a speaker having high bass reproduction performance (a large unit). Full bandwidth signals are output.
- SMALL:** This mode is used with a speaker having low bass reproduction performance (a small unit). The signals of 90Hz or less are mixed into the channel specified by LFE/BASS.
- NONE:** This mode is used with no center speaker. The center content is reduced by 3dB and distributed to FRONT L/R.

Sub-menu		Treble	Bass
6	Tone Control Flat	0 dB	0 dB
7	Tone Control +10dB	+10 dB	+10 dB
8	Tone Control -10dB	-10 dB	-10 dB

Reference data

INPUT: DVD ANALOG (Both ch)

Sub-menu	Input level	Volume	SPEAKER OUTPUT (1kHz)			SUBWOOFER OUTPUT (50Hz)	
			FRONT L/R	CENTER	SL/SR		
1	FRONT: SMALL 0dB	1kHz Both ch, -20 dBm	+6.0 dB	+11.5 dBm	- ∞	- ∞	- ∞
2	CENTER: NONE	1kHz Both ch, -20 dBm	+6.0 dB	+8.9 dBm	+7.5 dBm	- ∞	- ∞
3	LFE/BASS: FRONT	50Hz Both ch, -20 dBm	+6.0 dB	- ∞	- ∞	- ∞	+3.5 dBm
4	Presence Mix: 5ch	1kHz Both ch, -20 dBm	+6.0 dB	+11.5 dBm	- ∞	- ∞	- ∞
5	Surround B Power (Not applied to these models.)	1kHz Both ch, -20 dBm	+6.0 dB	- ∞	- ∞	- ∞	- ∞
6	Tone Control Flat	1kHz Both ch, -20 dBm	+6.0 dB	+11.5 dBm	+11.5 dBm	+11.5 dBm	-0.5 dBm
7	Tone Control +10dB	1kHz Both ch, -20 dBm	+6.0 dB	+13.4 dBm	+11.5 dBm	+11.5 dBm	-0.5 dBm
8	Tone Control -10dB	1kHz Both ch, -20 dBm	+6.0 dB	+9.6 dBm	+11.5 dBm	+11.5 dBm	-0.5 dBm

5. HP Test

The signal is output including the head margin.

FRONT 12dB MARGIN

5. FRONT12dB

Reference data

INPUT: DVD ANALOG

SWFR: 50Hz, Others: 1kHz

Input level	Volume	SPEAKER OUTPUT (1kHz)			SUBWOOFER OUTPUT (50Hz)
		FRONT L/R	CENTER	SL/SR	
Both ch, -20 dBm	+6.0 dB	+11.5 dBm	- ∞	- ∞	- ∞

FRONT 15dB MARGIN

5. FRONT15dB

Reference data

INPUT: DVD ANALOG

SWFR: 50Hz, Others: 1kHz

Input level	Volume	SPEAKER OUTPUT (1kHz)			SUBWOOFER OUTPUT (50Hz)
		FRONT L/R	CENTER	SL/SR	
Both ch, -20 dBm	+6.0 dB	+14.5 dBm	- ∞	- ∞	- ∞

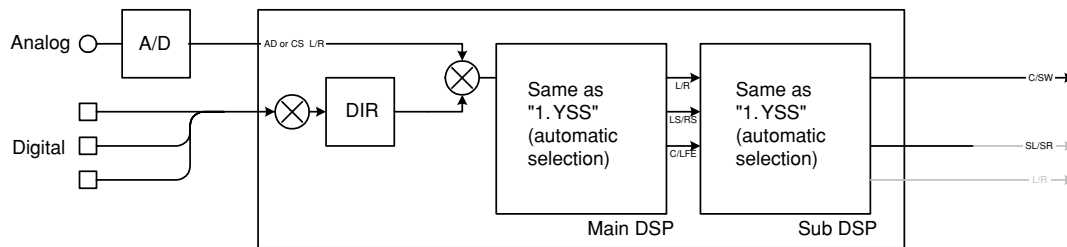

(Shaded items not used in this example)

6. OTHER INPUT

The signal input through the 6CH INPUT terminals is output.

EXTERNAL DECODER

6. EXTERNAL DEC

Reference data

INPUT: 6CH INPUT

SWFR: 50Hz, Others: 1kHz

Input level	Volume	SPEAKER OUTPUT (1kHz)			SUBWOOFER OUTPUT (50Hz)
		FRONT L/R	CENTER	SL/SR	
Both ch, -20 dBm	+6.0 dB	+11.5 dBm	+11.5 dBm	+11.5 dBm	-10.5 dBm

RX-V357/HTR-5830

7. DISPLAY CHECK

This program is used to check the FL display section. The display condition varies as shown below according to the sub-menu operation. The signals are processed using EFFECT OFF (The L/R signal is output using ANALOG FRONT BYPASS.)

Regarding internal/external synchronization selection of the image signals by the microprocessor control, the internal synchronization is selected when the initial display is provided and when all FL's light up and the external synchronization at any other time.

Also, except when the initial display is provided, 128 characters for confirmation of the OSD driver are displayed as the image output.

Segment conditions of the FL driver and the FL tube are checked by turning ON and OFF all segments. Next, the operation of the FL driver is checked by using the dimmer control. Then a short between segments next to each other is checked by turning ON and OFF all segments alternately (in lattice). (In the example below, the segments in the second row from the top are shorted.)

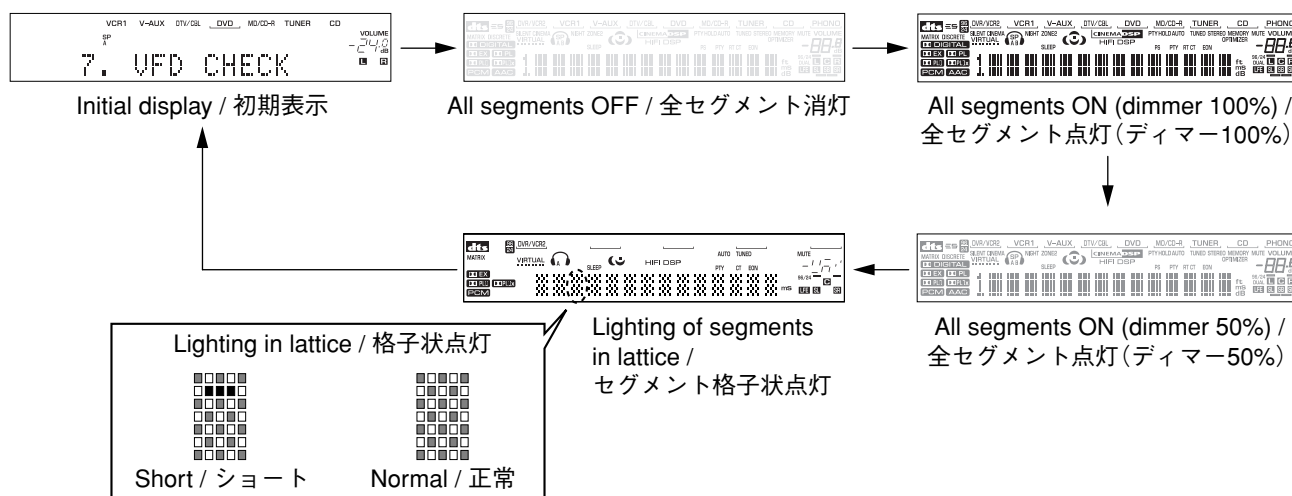

8. MANUAL TEST

The noise generator built into the DSP outputs the test noise through the channels specified by the sub-menu. The noise frequency for LFE is 35 to 250 Hz. Other than that, the center frequency is 800Hz.

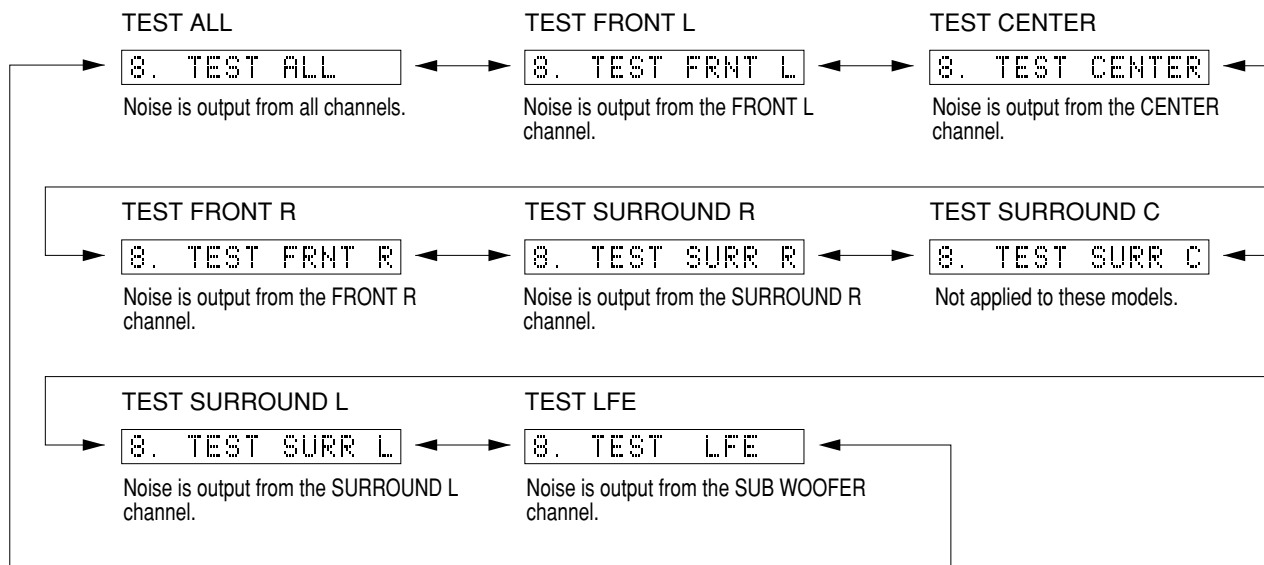

RX-V357/HTR-5830

9. FACTORY PRESET

This menu is used to reserve and inhibit initialization of the back-up RAM. The signals are processed using EFFECT OFF. (The L/R signal is output using ANALOG FRONT BYPASS.)

9. PRESET INHI



9. PRESET RSRV

PRESET INHIBIT (Initialization inhibited)

RAM initialization is not executed. Select this sub-menu to protect the values set by the user. The production history is not erased using this sub-menu.

PRESET RESERVED (Initialization reserved)

Initialization of the back-up RAM is reserved. (Actually, initialization is executed the next time that the power is turned on.) Select this sub-menu to reset to the original factory settings or to reset the RAM. The production history is not erased using this sub-menu.

CAUTION: Before setting to the PRESET RESERVED, write down the existing preset memory content of the Tuner in a table as shown below. (This is because setting to the PRESET RESERVED will cause the user memory content to be erased.)

Preset group	P1	P2	P3	P4	P5	P6	P7	P8
A								
B								
C								
D								
E								

• PRESET STATIONS / プリセット局

STATION		FM FACTORY PRESET DATA (MHz)	
PAGE	NO.	U, C	R, T, K, A, B, G, L, E
A/C/E	1	87.5	87.5
	2	90.1	90.1
	3	95.1	95.1
	4	98.1	98.10
	5	107.9	108.0
	6	88.1	88.1
	7	106.1	106.1
	8	107.9	108.0

STATION		AM FACTORY PRESET DATA (kHz)	
PAGE	NO.	U, C, R	T, K, A, B, G, L, E
B/D	1	630	630
	2	1080	1080
	3	1440	1440
	4	530	531
	5	1710	1611
	6	900	900
	7	1350	1350
	8	1400	1404

10. AD DATA CHECK/FAN TEST

This menu is used to display the A/D conversion value of the terminals which detects panel keys of the main unit and protection functions in % using the sub-menu. During signal processing, the condition before execution is maintained.

* The figures in the diagram are given as reference only.

DC/PS (protection detection)

DC: DC protection value

Normal value: 17 to 29 (Reference: 5V=100%)

If DC is out of the normal value range, the protection function works to turn off the power.

PS: Power supply voltage protection value

Normal value: 8 to 26 (Reference: 5V=100%)

If PS is out of the normal value range, the protection function works to turn off the power.

DC: 23% PS: 16%

THM/Fan (temperature detection/fan drive level)

THM: Temperature detection value

Normal value: 30 to 147 (Reference: 5V=500%)

If THM is out of the normal value range, the protection function works to turn off the power.

Fan: Current fan drive level on the left and the past fan drive history on the right.

(Not applied to these models.)

THM 43% Fan.../...

REC-OUT

Not applied to these models.

REC-OUT:

IMP SW/POWER LIMIT (Impedance/power limiter detection)

IMP: 8 or 6 ohms impedance switch setting (U, C models)

PL: Power limiter detection value (Reference: 5.0V=255%)
The voltage value of pin No. 91 of IC242 is displayed.
The port (pin No. 4 of IC242) output is controlled by using the input voltage.

value of pin No. 91 of IC242.

When higher than VthH, the port output is changed from H to L.

When lower than VthL, the port output is changed from L to H.

Note:

Vth=Threshold voltage

Detection level

PORT	VthL	VthH	
No. 91	2.41V	2.90V	U, C models (8ohms)
	2.77V	3.25V	U, C models (6ohms)
	2.87V	3.35V	R, T, K, A, B, G, E, L models (6ohms)

Output level

PORT	VthL	VthH	
No. 4	3.82V	0V	U, C models (8ohms)
	3.55V	0V	U, C models (6ohms)
	3.63V	0V	R, T, K, A, B, G, E, L models (6ohms)

IMP: 8 PL: 255%

K0/K1 (Panel key of main unit) (Reference: 5V=100%)

A/D of the key fails to function properly when the standard value is deviated. In this case, check the constant of partial pressure resistor, solder condition, etc. Refer to table 1.

K0: 100% K1: 100%

[Table 1]

U, C, R, T, K, A, L models

Display (%)	K0	K1
0 - 6	6CH INPUT	TUNING MODE
7 - 13	INPUT SELECT RIGHT	MEMORY
14 - 21	INPUT SELECT LEFT	PRESET / TUNING ▷
22 - 31	INPUT MODE	PRESET / ◁ TUNING
32 - 41	PROGRAM ▷	A/B/C/D/E
42 - 53	◁ PROGRAM	FM/AM
54 - 63	BASS / TREBLE +	PRESET / TUNING
64 - 72	BASS / TREBLE -	-
73 - 80	STEREO	-
81 - 88	CONTROL	-
89 - 95	SPEAKERS	-
96-100	KEY OFF	KEY OFF

B, G, E models

Display (%)	K0	K1
0 - 6	6CH INPUT	TUNING MODE
7 - 13	INPUT SELECT RIGHT	MEMORY
14 - 21	INPUT SELECT LEFT	PRESET / TUNING ▷
22 - 31	INPUT MODE	PRESET / ◁ TUNING
32 - 41	PROGRAM ▷	A/B/C/D/E
42 - 53	◁ PROGRAM	FM/AM
54 - 63	BASS / TREBLE +	PRESET / TUNING
64 - 72	BASS / TREBLE -	PTY SEEK MODE
73 - 80	STEREO	PTY SEEK START
81 - 88	CONTROL	EON
89 - 95	SPEAKERS	RDS MODE
96-100	KEY OFF	KEY OFF

When K0/K1 menu is selected, keys become non-operable due to detection of the values of all keys. However, it is possible to advance to the next sub-menu by turning the VOLUME of the main unit. When using this function, note that turning the VOLUME more than 2 clicks will cause the volume value to change.

FAN DRIVE TEST (Not applied to these models.)

HIGH

FAN TEST: HIGH

FAN DRIVE TEST (Not applied to these models.)

MID

FAN TEST: MID

FAN DRIVE TEST (Not applied to these models.)

LOW

FAN TEST: LOW

11. IF STATUS (Input function status)

Using the sub-menu, the status data is displayed one after another in the hexadecimal notation.

During signal processing, the status before execution of this menu is maintained.

* Numeric values in the figure example are for reference.

IS1, 2 (Internal status):

Indicates the status information of the microprocessor.

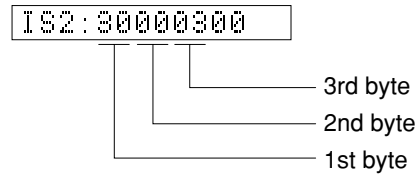
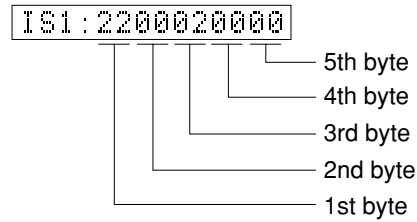

<1st byte> Digital input/output setting value
 Upper 4 bits: REC OUT selected /
 lower 4 bits: INPUT selected

Value	Choice	Preset name
0	NONE	
1	OPTA	
2	OPTB	DTV/CBL
3	OPTC	DVD
4	OPTD	
6	OPTF	
8	COAXA	CD
9	COAXB	

<2nd byte> Fs information of reproduction signal

Display	00	01	02	03	04	05	06	0A	0B	0C	0D
Fs (kHz)	Analog	32	44.1	48	64	88.2	96	Unknown NRM	Unknown DBL	Unknown QUAD	Not defined

<3rd byte> Audio code mode information of reproduction signal

Display	00	01	02	03	04	05	06	07	08	09	0A	0B	0C	0D
Audio Code	1+1	1/0	2/0	3/0	2/1	3/1	2/2	3/2	2/3	3/3	OVER 6.1	MULTI MONO	MULTI PCE	Unknown

<4th byte> Format information of reproduction signal

*1: Analog processing used for digital reproduction is not possible because of a commercial bit or 4-ch audio reason.

Display	Signal format
00	Analog (Unlock)
01	*1
10	PCM Audio
20	Digital Data
21	IEC1937 Data
22	None PCM
23	Unknown
50	dts
51	Red dts
54	dts-ES MATRIX
58	dts-ES DISCRETE
5C	dts-ES (Both flag)
60	AAC
C0	Dolby Digital
C1	D.D. Karaoke
C4	D.D.6.1 (D.D.EX)

<5th byte> Signal processing status information

*2: With digital signals other than 32kHz, 44.1kHz and 48kHz, through processing method is used for reproducable signals.

bit7	MUTE request	bit3	–
bit6	Red dts flashing	bit2	Through & bypass (*2)
bit5	6.1/EX processing	bit1	–
bit4	FULL MUTE (ON: 1)	bit0	dts analog mute

CS1-5: Indicates channel status information of the input signal (IEC60958).

CS1: FFFFFFFF --- CS5: FFFFFFFF

BY1-4: Indicates information of the bit stream included in the DOLBY DIGITAL signal.

BY1: FFFFFFFF --- BY4: FFFFFFFF

BS1-5: Indicates information of the bit stream included in the dts signal.

BS1: FFFFFFFF --- BS5: 1B

YS1-3: Indicates device status information of YSS938 (IC601).

* The numeric value in the figure is an example for reference.

YS1: A382000069

Byte No.	Function
1	YSS MUTE Reg
2	YSS MODE Reg
3	YSS IPORT BIT 7-0
4	YSS IPORT BIT 14-8
5	YSS OPORT

YS2: 0000000000

Byte No.	Function
1	IEC 1937 Preamble Pc
2	Data Stream Reg
3	Status Reg
4	YSS ZERO Reg
5	MIREG

YS3: 6006603D

Byte No.	Function
1	DIR Status
2	DIR fs
3	DIR fs count
4	YSS ZERO BF

SD: CS49329 Unsolicited Messages (AUTODETECT_RESPONSE)
(Not applied to these models.)

SD : FFFFFFFF

MTT: Mute Trigger

MTT: 0018001800

Byte No.	Function
1	Mute condition
2	Factor of the last mute
3	Error count of YSS938-FSCNT
4	Mute count by YSS938-FSCNT
5	Error factor of down load of CS49329

12. DSP RAM CHECK

This menu is used to self-diagnose whether or not the bus connection for the YSS938 and the external RAM is made properly.

During signal processing, the status before execution of this menu is maintained.

The address bus and the data bus are checked and the connection condition is displayed.

When no error is detected, "NoEr" appears on display.

YSS938 Bus Check

YSS BUS: NoEr

Display	Description
WAIT	Bus is being checked.
NoEr	No error detected.
DATA	Data bus shorted or open.
RSCS	/RAS or /CAS shorted, or open.
ADDR	Address bus shorted or open.

PLD / SRAM BUS CHECK

SD BUS: None

Display	Description
WAIT	Bus is being checked.
None	No error detected.
EDxx	Data bus shorted or open. (XX: 00-07)
EAXx	Address bus shorted or open. (XX: 00-0E)

13. SD DL CODE

This menu is used to display the data version of the FLASH ROM, TOC information and sum calculated value for the second decoder.

RDV

Displays the data version.

```
RDV:XXXXXXXX
```

TA 0-5

Displays the TOC information.

```
TA0:FFFFFFFF
```

SA 0-5

Displays the sum calculated value.

```
SA0:FFFFFFFF
```

14. SOFT SW

This menu is used to switch the function settings on the P.C.B. through the software so as to activate the product. The protection function follows the P.C.B. settings. When connected to AC or in the maker preset state, the unit is initialized to the P.C. B. setting. Display of each function after initialization varies depending on settings on P.C.B. The operation mode can be changed by selecting the sub-menu and then using the EFFECT key. With SOF selected for the SW mode, the settings become effective.

SW MODE: PCB or SOFT can be selected.

```
14. SW :PCB
```

MODEL SETTING: V357 or V357T can be selected.

As there is no model to replace with, this mode is used the check for the T destination.

```
14. MODEL:V357
```

TUNER DESTINATION: UC, AKGTE or RL can be selected.

```
14. DEST :UC
```

TUNER: NOT or EXIST can be selected.

```
14. TUNER:EXIST
```

RDS: NOT or EXIST can be selected.

```
14. RDS :NOT
```

ZONE2: NOT or EXIST can be selected.
(Not applied to these models.)

```
14. ZONE2:NOT
```

VIDEO FORMAT: NTSC or PAL can be selected.
(Not applied to these models.)

```
14. VIDEO:-----
```

15. MICROPROCESSOR INFORMATION

The version, checksum and the port specified by the microprocessor are displayed. The signal is processed using EFFECT OFF. The checksum is obtained by adding the data at every 8 bits for each program area and expressing the result as a 4-figure hexadecimal data.

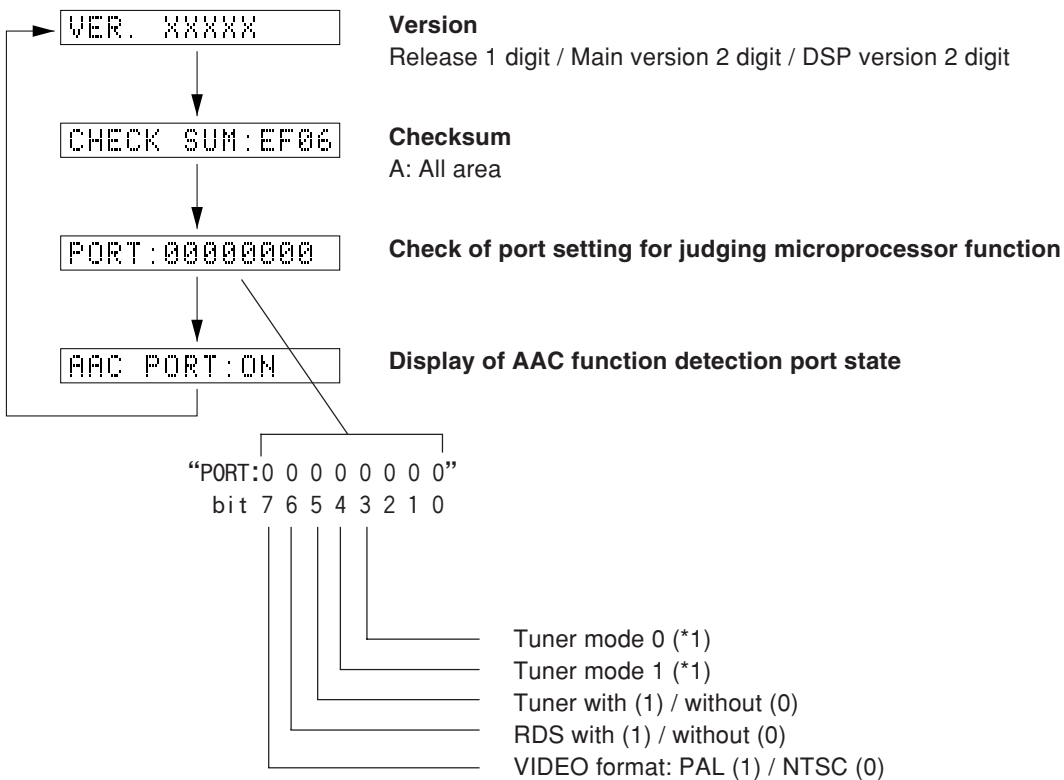

*1

Type	Tuner mode		Port 3 (type 2)	Frequency range	
	1	0		FM	AM
0	0	0	—	76.0-90.0MHz / 100kHz	531-1611kHz / 9kHz
1	1	0	—	87.5-108.0MHz / 50kHz	531-1611kHz / 9kHz
2	0	1	—	87.5-107.9MHz / 200kHz	530-1710kHz / 10kHz
3	1	1	Low	87.5-108.0MHz / 100kHz	530-1710kHz / 10kHz
			High	87.5-108.0MHz / 50kHz	531-1611kHz / 9kHz

■ CONFIRMATION OF IDLING CURRENT

Confirmation of Idling Current of MAIN (1) P. C. B.

- Right after the power is turned on, confirm that the voltage across the terminals of R157 (FRONT Lch), R158 (FRONT Rch), R148 (CENTER), R156 (SURROUND Lch), R159 (SURROUND Rch) are between 0.1mV and 10.0mV.

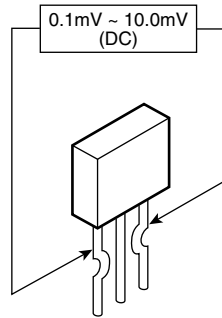

R157 (FRONT Lch)
R158 (FRONT Rch)
R148 (CENTER)
R156 (SURROUND Lch)
R159 (SURROUND Rch)

■ DISPLAY DATA

● V851 : 16-BT-122GNK (WC173100)

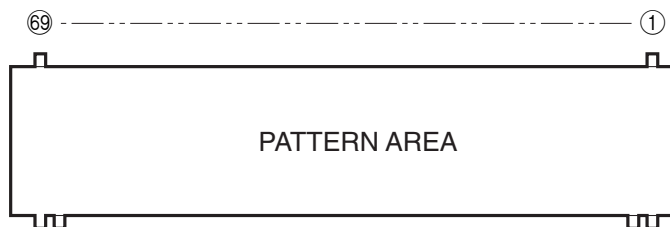

● PIN CONNECTION

Pin No.	69	68	67	66	65	64	63	62	61	60	59	58	57	56	55	54	53	52	51	50	49	48	47	46	45	44	43	42	41	40	39	38	37	36	35
Connection	F2	F2	NP	NP	P1	P2	P3	P4	P5	P6	P7	P8	P9	P10	P11	P12	P13	P14	P15	P16	P17	P18	P19	P20	P21	P22	P23	P24	P25	P26	P27	P28	P29	P30	P31
Pin No.	34	33	32	31	30	29	28	27	26	25	24	23	22	21	20	19	18	17	16	15	14	13	12	11	10	9	8	7	6	5	4	3	2	1	
Connection	P32	P33	P34	P35	P36	P37	P38	NX	NX	NX	NX	NX	NX	NX	16G	15G	14G	13G	12G	11G	10G	9G	8G	7G	6G	5G	4G	3G	2G	1G	NP	NP	F1	F1	

Note : 1) F1, F2 Filament 2) NP No pin 3) NX No extended 4) DL Datum line 5) 1G ~ 16G Grid

● GRID ASSIGNMENT

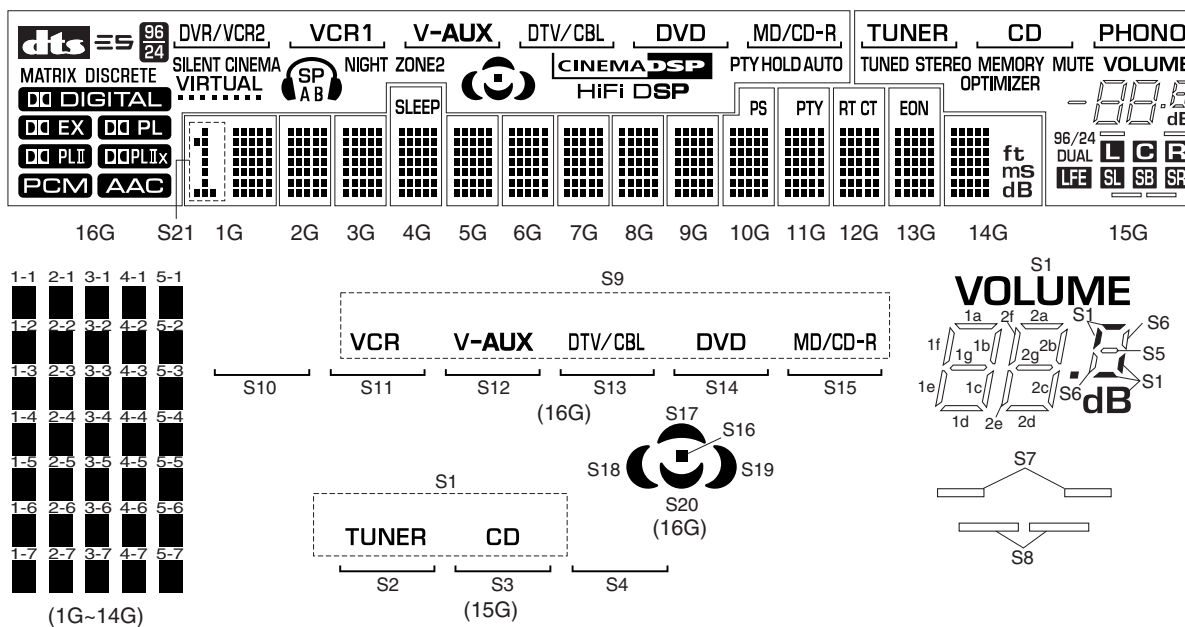

RX-V357/HTR-5830

● ANODE CONNECTION

	16G	15G	14G	13G	12G	11G	10G	9G~5G	4G	3G	2G	1G
P1	dtS	S1	1-1	1-1	1-1	1-1	1-1	1-1	1-1	1-1	1-1	1-1
P2	ES	S7	2-1	2-1	2-1	2-1	2-1	2-1	2-1	2-1	2-1	2-1
P3	MATRIX	S8	3-1	3-1	3-1	3-1	3-1	3-1	3-1	3-1	3-1	3-1
P4	DISCRETE	—	4-1	4-1	4-1	4-1	4-1	4-1	4-1	4-1	4-1	4-1
P5	96/24	1a	5-1	5-1	5-1	5-1	5-1	5-1	5-1	5-1	5-1	5-1
P6	DIGITAL	1b	1-2	1-2	1-2	1-2	1-2	1-2	1-2	1-2	1-2	1-2
P7	EX	1c	2-2	2-2	2-2	2-2	2-2	2-2	2-2	2-2	2-2	2-2
P8	PL	1d	3-2	3-2	3-2	3-2	3-2	3-2	3-2	3-2	3-2	3-2
P9	PLII	1e	4-2	4-2	4-2	4-2	4-2	4-2	4-2	4-2	4-2	4-2
P10	AAC	1f	5-2	5-2	5-2	5-2	5-2	5-2	5-2	5-2	5-2	5-2
P11	PCM	1g	1-3	1-3	1-3	1-3	1-3	1-3	1-3	1-3	1-3	1-3
P12	ZONE2	2a	2-3	2-3	2-3	2-3	2-3	2-3	2-3	2-3	2-3	2-3
P13	VIRTUAL	2b	3-3	3-3	3-3	3-3	3-3	3-3	3-3	3-3	3-3	3-3
P14	SILENT CINEMA	2c	4-3	4-3	4-3	4-3	4-3	4-3	4-3	4-3	4-3	4-3
P15		2d	5-3	5-3	5-3	5-3	5-3	5-3	5-3	5-3	5-3	5-3
P16	SP	2e	1-4	1-4	1-4	1-4	1-4	1-4	1-4	1-4	1-4	1-4
P17	A	2f	2-4	2-4	2-4	2-4	2-4	2-4	2-4	2-4	2-4	2-4
P18	B	2g	3-4	3-4	3-4	3-4	3-4	3-4	3-4	3-4	3-4	3-4
P19	HIFI DSP	S5	4-4	4-4	4-4	4-4	4-4	4-4	4-4	4-4	4-4	4-4
P20	CINEMA DSP	S6	5-4	5-4	5-4	5-4	5-4	5-4	5-4	5-4	5-4	5-4
P21	S16	PHONO	1-5	1-5	1-5	1-5	1-5	1-5	1-5	1-5	1-5	1-5
P22	S17	S2	2-5	2-5	2-5	2-5	2-5	2-5	2-5	2-5	2-5	2-5
P23	S18	S3	3-5	3-5	3-5	3-5	3-5	3-5	3-5	3-5	3-5	3-5
P24	S19	S4	4-5	4-5	4-5	4-5	4-5	4-5	4-5	4-5	4-5	4-5
P25	S20	STEREO	5-5	5-5	5-5	5-5	5-5	5-5	5-5	5-5	5-5	5-5
P26	S9	TUNED	1-6	1-6	1-6	1-6	1-6	1-6	1-6	1-6	1-6	1-6
P27	DVR/VCR2	MEMORY	2-6	2-6	2-6	2-6	2-6	2-6	2-6	2-6	2-6	2-6
P28	1	MUTE	3-6	3-6	3-6	3-6	3-6	3-6	3-6	3-6	3-6	3-6
P29	S10	OPTIMIZER	4-6	4-6	4-6	4-6	4-6	4-6	4-6	4-6	4-6	4-6
P30	S11	96/24	5-6	5-6	5-6	5-6	5-6	5-6	5-6	5-6	5-6	5-6
P31	S12	DUAL	1-7	1-7	1-7	1-7	1-7	1-7	1-7	1-7	1-7	1-7
P32	S13	LFE	2-7	2-7	2-7	2-7	2-7	2-7	2-7	2-7	2-7	2-7
P33	S14	L	3-7	3-7	3-7	3-7	3-7	3-7	3-7	3-7	3-7	3-7
P34	NIGHT	C	4-7	4-7	4-7	4-7	4-7	4-7	4-7	4-7	4-7	4-7
P35	DOLBYx	R	5-7	5-7	5-7	5-7	5-7	5-7	5-7	5-7	5-7	5-7
P36	S15	SL	ft	EON	RT	PTY	PS	—	SLEEP	—	—	S21
P37	AUTO	SB	mS	—	CT	—	—	—	—	—	—	—
P38	PTY HOLD	SR	dB	—	—	—	—	—	—	—	—	—

IC DATA

IC242: M30626FHPFP (MAIN P.C.B.)

16bit μ -COM (Main CPU)

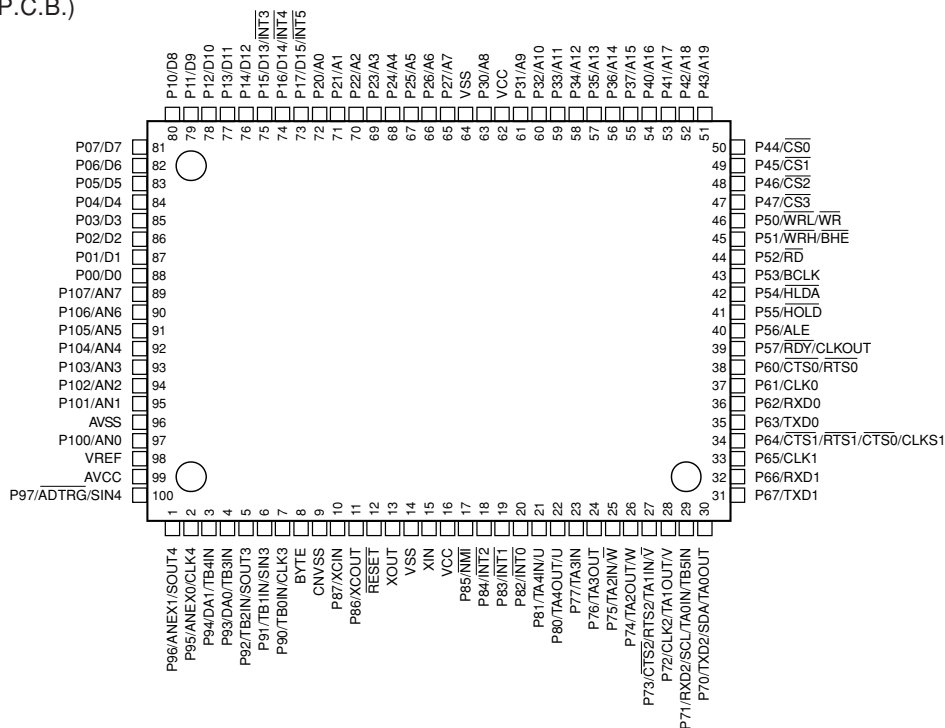

No.	Port No.	Function name	I/O	Detail of function
1	SOUT4	DTFD	SO	FL Driver TxD
2	CLK4	CKFD	SCK	FL Driver CLOCK
3	P94	/BLK	O	FL Driver OFF
4	P93	LIMB	O	Power Limiter Control
5	SOUT3	SDM	SO	YSS938 TxD
6	SIN3	SDD	SI	YSS938 RxD
7	CLK3	YSSCK	SCK	YSS938 CLOCK
8	BYTE	YSS	VSS	Vss: when single chip mode is used
9	CNVss	CNVss	Vss/Vcc	Vss: when single chip mode is used, Vcc: when flash writing is used
10	P87	CSY	O	YSS938 CE
11	P86	/ICD	O	YSS938/DA/AD/CODEC/DEM
12	RESET	RESET	I	Reset
13	Xout	Xout		Oscillator Out
14	Vss	Vss	Vss	μ -COM Ground
15	Xin	Xin	16MHz	Oscillator in
16	Vcc	Vcc	Vcc (BU)	μ -COM power supply, +5V
17	NMI	NMI	Vcc (BU)	Connect to Vcc because it is unused.
18	INT2	INT938	INT	YSS938 IPINT/MUTE/DIR
19	INT1	PSW	INT	Standby SW Input
20	INT0	REM1	INT	Remote Control Input
21	P81		I	Open (Unconnected)
22	P80		O	Open (Unconnected)
23	P77	/HP	I (IPU)	Headphone Detect
24	P76	VRA	I (IPU)	Volume Rotary A
25	P75	VRB	I (IPU)	Volume Rotary B
26	P74	CSN	O	Chip Select for DAC (Unconnected)
27	P73	/ICCDC	O	CODEC Reset
28	CLK2		O	Open (Unconnected)
29	P71		O	Open (Unconnected)
30	TXD2		O	Open (Unconnected)
31	TXD1	TXDF	FLASH	Flash ROM Serial Write Data Transmission
32	RXD1	RXDF	FLASH	Flash ROM Serial Write Data Reception
33	CLK1	CLKF	FLASH	Flash ROM Serial Clock
34	P64	BSY	FLASH	Flash BUSY Signal Output
35	TXD0	IMP	I	IMPEDANCE Select SW detection
36	RXD0	5/6	SI	Open (Unconnected)
37	CLK0		CLK	Open (Unconnected)
38	P60	/CEEEP	O	EEPROM CE
39	P57	SDTR	O	RDS/OSD TxD
40	P56	SDRR/DEST	SI/I (IPU)	RDS RxD / Frequency SW (Dest R)
41	P55	/EMP	GND	For Flash Writing (LO)
42	P54	SCKR	SCK	RDS/OSD Clock
43	P53		O	Open (Unconnected)

RX-V357/HTR-5830

IC242: M30626FHPFP (MAIN P.C.B.)

16bit μ -COM (Main CPU)

No.	Port No.	Function name	I/O	Detail of function
44	P52		O	Open (Unconnected)
45	P51		O	Open (Unconnected)
46	P50	/CE	I	For Flash Writing (HI)
47	P47		I/O	Open (Unconnected)
48	P46	/MMT	O	Mute Front
49	P45	/CMT	O	Mute Center
50	P44	/SMT	O	Mute Surround
51	P43	/MTSW	O	Mute LFE
52	P42		O	Open (Unconnected)
53	P41	HPRY	O	Headphone SP Relay Output
54	P40		O	Open (Unconnected)
55	P37	/GAIN	O	Gain
56	P36	BD_MUTE	O	BD3816 Mute
57	P35	HPF	O	HPF
58	P34	BD_CLK	O	Clock Line for BD38xx System Control
59	P33	BD_DAT	O	Data Line for BD38xx System Control
60	P32	VIA	O	Video Selector A
61	P31	VIB	O	Video Selector B
62	Vcc	Vcc	Vcc (BU)	μ -COM Power Supply, +5V
63	P30		O	Open (Unconnected)
64	Vss	Vss	Vss	μ -COM Ground
65	P27	/VR1	O	Video Rec Out Selector 1
66	P26		O	Open (Unconnected)
67	P25	CMP0	O	Component Selector 0
68	P24	CMP1	O	Component Selector 1
69	P23		O	Open (Unconnected)
70	P22		O/I	Open (Unconnected)
71	P21		O	Open (Unconnected)
72	P20	RDSE	O/I	RDS Enable, RDS Present/Absent
73	P17	CEP/TUN1	O/I	PLL IC Enable/Destination Discriminate 1
74	INT4	PDET	INT	Power Down Detect INT
75	INT3	5M SW	INT	5M Switch Output
76	P14	SCKP/TUN0	O/I	PLL IC Clock/Destination Discriminate 0
77	P13	SDTP	O	PLL IC Tx D
78	P12	SDRP	I (IPU)	PLL IC Rx D
79	P11	TUNED	I (IPU)	Tuned
80	P10	/ST	I (IPU)	Tuner/ST
81	P07	TMT	O	Tuner Mute
82	P06	PRY	O	Power Relay Output
83	P05	CSRY	O	Surround SP Relay Output
84	P04	MARYB	O	Front B SP Relay Output
85	P03	MARYA	O	Front A SP Relay Output
86	P02	PRI	I	Protection Excess Current Detect
87	P01	LIMA	O	Open (Unconnected)
88	P00		O	Open (Unconnected)
89	AN7	MODEL	AD	Connection Discriminate
90	AN6	PRD	AD	Protection DC Detect
91	AN5	PREMT	AD	Power Limiter Detect
92	AN4	THM	AD	Temperature Detect
93	AN3		AD	Open (Unconnected)
94	AN2	ADKEY0	AD	Key AD Input 0
95	AN1	ADKEY1	AD	Key AD Input 1
96	Avss	Avss	Vss	AD Ground
97	AN0	PRV	AD	Protection Power Supply Voltage Detect
98	Vref	VREF	(+5v)	AD Reference
99	Avcc	AVcc	Vcc (BU)	AD Power Supply
100	P97	CEFD	O	FL Driver CE

Key Input (A-D) Pull-Up Resistance 10 k-ohms

U, C, R, T, K, A, L models

Ohm	0.0	+1.0k	+1.0k	+1.5k	+2.2k	+3.3k	+4.7k	+6.8k	+10.0k	+22.0k	+47.0k
V	0.0~0.3	~0.65	~1.05	~1.55	~2.05	~2.65	~3.15	~3.6	~4.0	~4.4	~4.75
ADKEY0 (94Pin, AN2)	6CH INPUT	INPUT	INPUT	INPUT	PROGRAM	PROGRAM	BASS/TREBLE	BASS/TREBLE	STEREO/EFFECT	TONE CONTROL	SPEAKERS A/B/OFF
ADKEY1 (95Pin, AN1)	TUNING MODE	MEMORY	PRESET/TUNING	PRESET/TUNING	A/B/C/D/E /NEXT	FM/AM	PRESET/TUNING /EDIT	-	-	-	-

B, G, E models

Ohm	0.0	+1.0k	+1.0k	+1.5k	+2.2k	+3.3k	+4.7k	+6.8k	+10.0k	+22.0k	+47.0k
V	0.0~0.3	~0.65	~1.05	~1.55	~2.05	~2.65	~3.15	~3.6	~4.0	~4.4	~4.75
ADKEY0 (94Pin, AN2)	6CH INPUT	INPUT	INPUT	INPUT	PROGRAM	PROGRAM	BASS/TREBLE	BASS/TREBLE	STEREO/EFFECT	TONE CONTROL	SPEAKERS A/B/OFF
ADKEY1 (95Pin, AN1)	TUNING MODE	MEMORY	PRESET/TUNING	PRESET/TUNING	A/B/C/D/E /NEXT	FM/AM	PRESET/TUNING /EDIT	PTY SEEK MODE	PTY SEEK START	EON	RDS MODE/FREQ

IC801 : YSS938 (DSP P.C.B.)
DSP

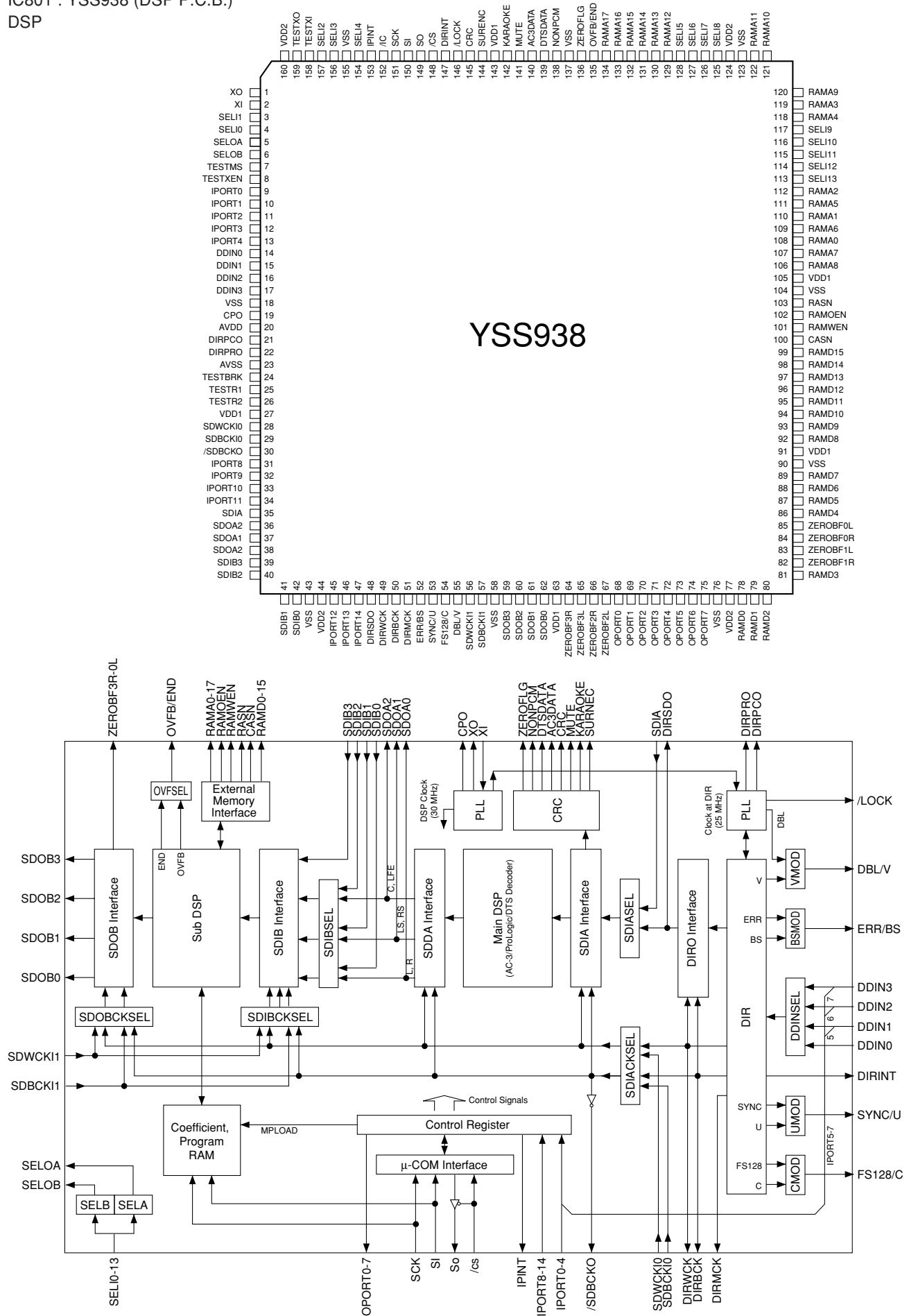

RX-V357/HTR-5830

IC801 : YSS938 (DSP P.C.B.)

DSP

No.	Name	I/O	Function
1	XO	O	Crystal oscillator connecting terminal
2	XI	I	Crystal oscillator connecting terminal (24.576MHz)
3	SELI1	I+	Built-in selector input 1 (AXD) (Unconnected)
4	SELI0	I+	Built-in selector input 0 (GND)
5	SELOA	O+	Built-in selector output A (ISEL)
6	SELOB	O+	Built-in selector output B (RSEL) (Unconnected)
7	TESTMS	I+	Test terminal (Unconnected)
8	TESTXEN	I+	Test terminal (Unconnected)
9	IPOINT0	I+	General purpose input terminal (CXDTA)
10	IPOINT1	I+	General purpose input terminal (CXDTB)
11	IPOINT2	I+	General purpose input terminal
12	IPOINT3	I+	General purpose input terminal
13	IPOINT4	I+	General purpose input terminal
14	DDIN0	Is	DIR: Digital audio interface data input terminal 0 (ISEL)
15	DDIN1	Is	DIR: Digital audio interface data input terminal 1/General purpose input terminal (Pull down)
16	DDIN2	Is	DIR: Digital audio interface data input terminal 2/General purpose input terminal (Pull down)
17	DDIN3	Is	DIR: Digital audio interface data input terminal 3/General purpose input terminal (Pull down)
18	VSS		Ground terminal
19	CPO	A	PLL filter connecting terminal
20	AVDD		+3.3V power terminal (for DIR)
21	DIRPCO	A	DIR: PLL filter connecting terminal
22	DIRPRO	A	DIR: PLL filter connecting terminal
23	AVSS		Ground terminal (for DIR)
24	TESTBRK	I+	Test terminal (Unconnected)
25	TESTR1	I+	PLL initialization signal input terminal for DSP (/ICD)
26	TESTR2	I+	Test terminal (Unconnected)
27	VDD1		+3.3V power terminal (for terminal section)
28	SDWCKI0	I+	Word clock input terminal for SDIA, SDOA, SDIB, SDOB interface (WCKG) (Unconnected)
29	SDBCKI0	I+	Bit clock input terminal for SDIA, SDOA, SDIB, SDOB interface (BCKG) (Unconnected)
30	/SDBCK0	O	DIRBCK or SDBCKI0 invert clock output terminal (Unconnected)
31	IPOINT8	I+	IPINT general purpose input terminal
32	IPOINT9	I+	IPINT general purpose input terminal (NONPCM)
33	IPOINT10	I+	IPINT general purpose input terminal (NONPCM)
34	IPOINT11	I+	IPINT general purpose input terminal (MUTE)
35	SDIA	I	AC-3/DTS bit stream (or PCM) data input terminal to Main DSP (SDIA)
36	SDOA2	O	PCM output terminal from Main DSP (C/LFE output) (Unconnected)
37	SDOA1	O	PCM output terminal from Main DSP (LS/RS output) (Unconnected)
38	SDOA0	O	PCM output terminal from Main DSP (L/R output) (Unconnected)
39	SDIB3	I+	PCM input terminal 3 to Sub DSP (Unconnected)
40	SDIB2	I+	PCM input terminal 2 to Sub DSP (Unconnected)
41	SDIB1	I+	PCM input terminal 1 to Sub DSP (Unconnected)
42	SDIB0	I+	PCM input terminal 0 to Sub DSP (Unconnected)
43	VSS		Ground terminal
44	VDD2		+2.5V power terminal (for internal circuit)
45	IPOINT12	I+	IPINT general purpose input terminal (DIRINT)
46	IPOINT13	I+	IPINT general purpose input terminal (DBL)
47	IPOINT14	I+	IPINT general purpose input terminal (DBL)
48	DIRSDO	O	AC-3/DTS bit stream (or PCM) data output terminal from DIR (Unconnected)
49	DIRWCK	O	DIR: Serial data word clock (fs) output terminal (WCK)
50	DIRBCK	O	DIR: Serial data bit clock (64fs) output terminal (BCK)
51	DIRMCK	O	DIR: Serial data master clock (256fs or 128fs) output terminal (MCK)
52	ERR/BS	O	DIR: Data error detect output/block start output terminal (Unconnected)
53	SYNC/U	O	DIR: Serial data synchronous timing output/user data output terminal (Unconnected)
54	FS128/C	O	DIR: Serial data master clock 128fs output/channel status output terminal (FS128) (Unconnected)
55	DBL/V	O	DIR: Double rate clock output/validity flag output terminal (DBL)

IC801 : YSS938 (DSP P.C.B.)

DSP

No.	Name	I/O	Function	
56	SDWCK11	I+	Word clock input terminal for SDIB, SDOB interface	(WCKG) (Unconnected)
57	SDBCK11	I+	Bit clock input terminal for SDIB, SDOB interface	(BCKG) (Unconnected)
58	VSS		Ground terminal	
59	SDOB3	O	PCM output terminal from Sub DSP	
60	SDOB2	O	PCM output terminal from Sub DSP	
61	SDOB1	O	PCM output terminal from Sub DSP	
62	SDOB0	O	PCM output terminal from Sub DSP	
63	VDD1		+3.3V power terminal (for terminal section)	
64	ZEROBF3R	O+	SDOB3 Rch zero flag output terminal	(ZF3R) (Unconnected)
65	ZEROBF3L	O+	SDOB3 Lch zero flag output terminal	(ZF3L) (Unconnected)
66	ZEROBF2R	O+	SDOB2 Rch zero flag output terminal	(ZF2R) (Unconnected)
67	ZEROBF2L	O+	SDOB2 Lch zero flag output terminal	(ZF2L) (Unconnected)
68	OPORT0	O	General purpose output terminal	(/RINH1) (Unconnected)
69	OPORT1	O	General purpose output terminal	(/RINH2) (Unconnected)
70	OPORT2	O	General purpose output terminal	(/ICDA)
71	OPORT3	O	General purpose output terminal	(/ICAD) (Unconnected)
72	OPORT4	O	General purpose output terminal	(DPS)
73	OPORT5	O	General purpose output terminal	(RST) (Unconnected)
74	OPORT6	O	General purpose output terminal	(ERROR) (Unconnected)
75	OPORT7	O	General purpose output terminal	(/PRST) (Unconnected)
76	VSS		Ground terminal	
77	VDD2		+2.5V power terminal (for internal circuit)	
78	RAMD0	I+/O	Sub DSP: External memory data terminal 0	
79	RAMD1	I+/O	Sub DSP: External memory data terminal 1	
80	RAMD2	I+/O	Sub DSP: External memory data terminal 2	
81	RAMD3	I+/O	Sub DSP: External memory data terminal 3	
82	ZEROBF0R	O+	SDOB1 Rch zero flag output terminal	(ZF1R) (Unconnected)
83	ZEROBF0L	O+	SDOB1 Lch zero flag output terminal	(ZF1L) (Unconnected)
84	ZEROBF0R	O+	SDOB0 Rch zero flag output terminal	(ZF0R) (Unconnected)
85	ZEROBF0L	O+	SDOB0 Lch zero flag output terminal	(ZF0L) (Unconnected)
86	RAMD4	I+/O	Sub DSP: External memory data terminal 4	
87	RAMD5	I+/O	Sub DSP: External memory data terminal 5	
88	RAMD6	I+/O	Sub DSP: External memory data terminal 6	
89	RAMD7	I+/O	Sub DSP: External memory data terminal 7	
90	VSS		Ground terminal	
91	VDD1		+3.3V power terminal (for terminal section)	
92	RAMD8	I+/O	Sub DSP: External memory data terminal 8	
93	RAMD9	I+/O	Sub DSP: External memory data terminal 9	
94	RAMD10	I+/O	Sub DSP: External memory data terminal 10	
95	RAMD11	I+/O	Sub DSP: External memory data terminal 11	
96	RAMD12	I+/O	Sub DSP: External memory data terminal 12	
97	RAMD13	I+/O	Sub DSP: External memory data terminal 13	
98	RAMD14	I+/O	Sub DSP: External memory data terminal 14	
99	RAMD15	I+/O	Sub DSP: External memory data terminal 15	
100	CASN	O	Sub DSP: Column address strobe output terminal for external DRAM	
101	RAMWEN	O	Sub DSP: Write enable terminal for external memory	
102	RAMOEN	O	Sub DSP: Output enable terminal for external memory	
103	RASN	O	Sub DSP: Low address strobe output terminal for external DRAM	
104	VSS		Ground terminal	
105	VDD1		+3.3V power terminal (for terminal section)	
106	RAMA8	O	Sub DSP: External memory address terminal 8	
107	RAMA7	O	Sub DSP: External memory address terminal 7	
108	RAMA0	O	Sub DSP: External memory address terminal 0	
109	RAMA6	O	Sub DSP: External memory address terminal 6	
110	RAMA1	O	Sub DSP: External memory address terminal 1	

IC801 : YSS938 (DSP P.C.B.)

DSP

No.	Name	I/O	Function
111	RAMA5	O	Sub DSP: External memory address terminal 5
112	RAMA2	O	Sub DSP: External memory address terminal 2
113	SELI13	I+	Built-in selector input 13 (Unconnected)
114	SELI12	I+	Built-in selector input 12 (Unconnected)
115	SELI11	I+	Built-in selector input 11 (Unconnected)
116	SELI10	I+	Built-in selector input 10 (Unconnected)
117	SELI9	I+	Built-in selector input 9 (CXB) (Unconnected)
118	RAMA4	O	Sub DSP: External memory address terminal 4
119	RAMA3	O	Sub DSP: External memory address terminal 3
120	RAMA9	O	Sub DSP: External memory address terminal 9 (Unconnected)
121	RAMA10	O	Sub DSP: External memory address terminal 10 (Unconnected)
122	RAMA11	O	Sub DSP: External memory address terminal 11 (Unconnected)
123	VSS		Ground terminal
124	VDD2		+2.5V power terminal (for internal circuit)
125	SELI8	I+	Built-in selector input 8 (CXA)
126	SELI7	I+	Built-in selector input 7 (GND)
127	SELI6	I+	Built-in selector input 6 (OPTF) (Unconnected)
128	SELI5	I+	Built-in selector input 5 (Unconnected)
129	RAMA12	O	Sub DSP: External memory address terminal 12 (Unconnected)
130	RAMA13	O	Sub DSP: External memory address terminal 13 (Unconnected)
131	RAMA14	O	Sub DSP: External memory address terminal 14 (Unconnected)
132	RAMA15	O	Sub DSP: External memory address terminal 15 (Unconnected)
133	RAMA16	O	Sub DSP: External memory address terminal 16 (Unconnected)
134	RAMA17	O	Sub DSP: External memory address terminal 17 (Unconnected)
135	OVFB/END	O	Sub DSP: Overflow/program end detect terminal (Unconnected)
136	ZEROFLG	O	Main DSP: Zero flag output terminal (Unconnected)
137	VSS		Ground terminal
138	NONPCM	O	Main DSP: Non-PCM data detect terminal
139	DTSDATA	O	Main DSP: DTS data detect terminal (Unconnected)
140	AC3DATA	O	Main DSP: AC3 data detect terminal (Unconnected)
141	MUTE	O	Main DSP: Auto mute detect terminal
142	KARAOKE	O	Main DSP: AC3 KARAOKE data detect terminal (Unconnected)
143	VDD1	+3.3V	Power terminal (for terminal section)
144	SURENC	O	Main DSP: AC-3 2/0 mode Dolby surround encode input detect terminal (Unconnected)
145	CRC	O	Main DSP: AC3 CRC error detect terminal (Unconnected)
146	/LOCK	O	DIR: PLL lock detect terminal (Unconnected)
147	DIRINT	O	DIR: Interrupt output terminal
148	/CS	Is	Microprocessor interface chip select input terminal (/CSY)
149	SO	Ot	Microprocessor interface data output terminal (SDDY)
150	SI	Is	Microprocessor interface data input terminal (SDMYB)
151	SCK	Is	Microprocessor interface clock input terminal (SCKYB)
152	/IC	Is	Initial clear input terminal (/ICYP)
153	IPINT	O+	Interrupt output terminal by IPORT 8-14
154	SELI4	I+	Built-in selector input 4 (OPTD) (Unconnected)
155	VSS		Ground terminal
156	SELI3	I+	Built-in selector input 3 (OPTC)
157	SELI2	I+	Built-in selector input 2 (OPTB)
158	TESTXI	I	Test terminal (should be always connected to VSS)
159	TESTXO	O	Test terminal (Unconnected)
160	VDD2	+2.5V	Power terminal (for internal circuit)

Is: Schmidt trigger input terminal
I+: Input terminal with pull-up resistor
O: Digital output terminal
Ot: 3-state digital output terminal
A: Analog terminal

1 ■ PRINTED CIRCUIT BOARD (Foil side)

DSP P. C. B. (Side A)
Lead Free Solder Used

DSP P. C. B. (Side B)
Lead Free Solder Used

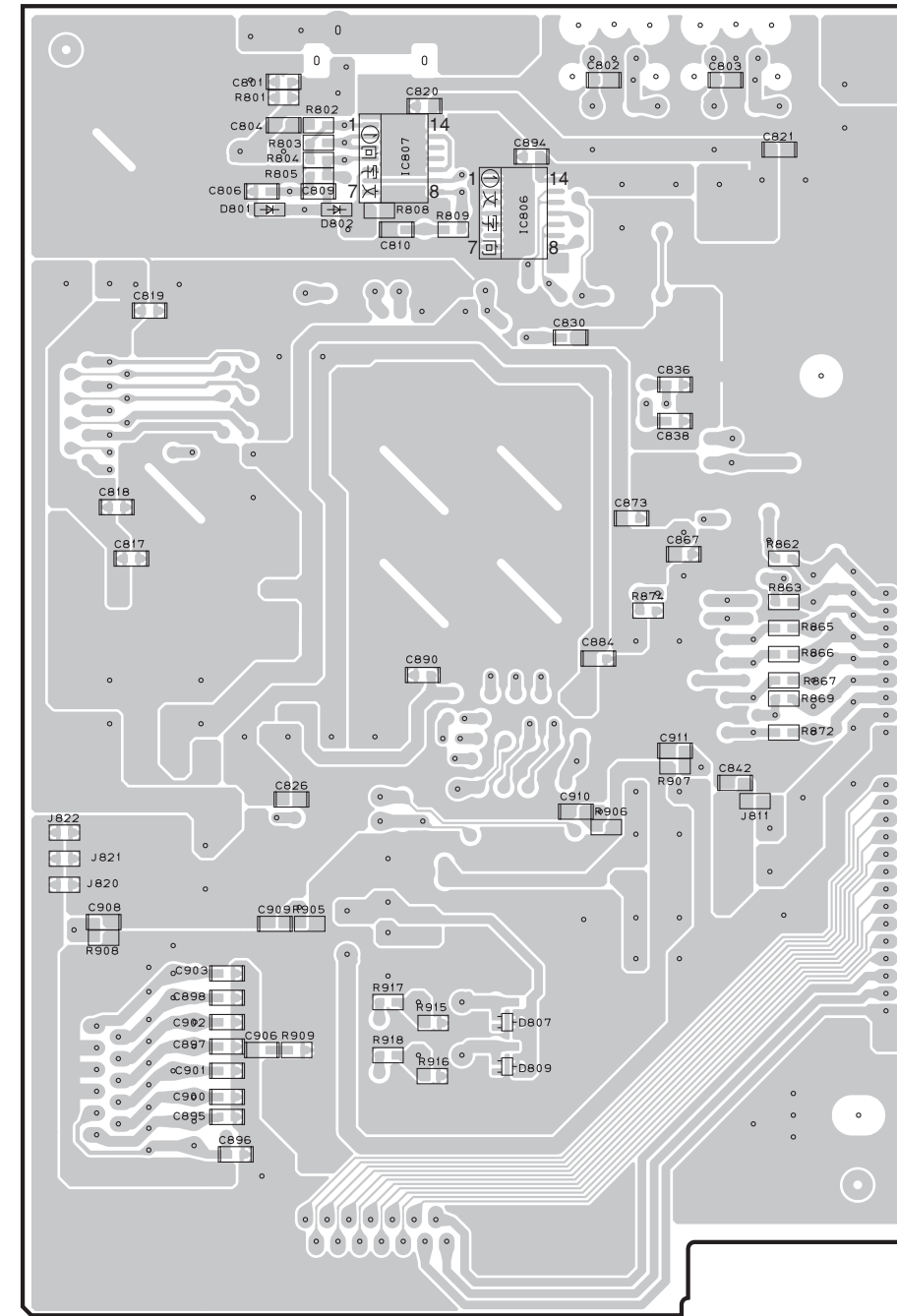
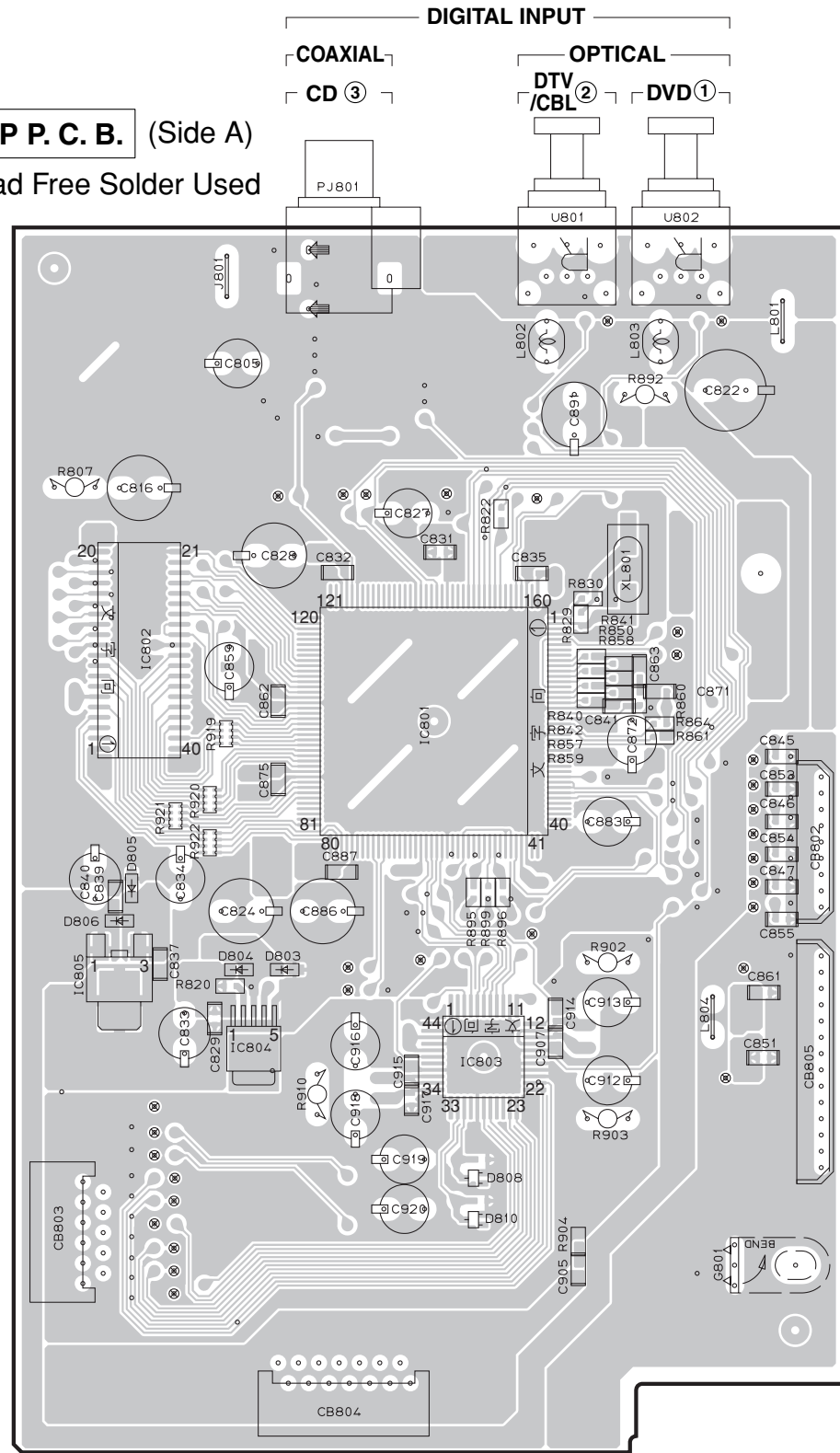

ADL
ADR
E
DAL
E
DAR
C
SW
RL
RR

FUNCTION (1)
CB453

VRB
VRA
REM1
PSW
BLK
CKFD
DTFD
CEFD
ADKEY1
ADKEY0
+5MS
VP
+5M
MG

FUNCTION (2)
CB551

MAIN (1)
CB247

SDM
SDD
YSSCK
CSY
/ICD
INT938
/ICDC
+5D1
+5D1

VRB
VRA
REM1
PSW
/BLK
CKFD
DTFD
CEFD
ADKEY1
ADKEY0
+5MS
MG
+5M
VP

MAIN (1)
CB249

• Semiconductor Location

Ref. no.	Location
D801	G3
D802	G3
D803	C5
D804	C5
D805	B4
D806	B5
D807	H5
D808	D5
D809	H6
D810	D6
IC801	C4
IC802	B4
IC803	D5
IC804	C5
IC805	B5
IC806	H3
IC807	G3

PRINTED CIRCUIT BOARD (Foil side)

FUNCTION (1) P. C. B. (Side A)

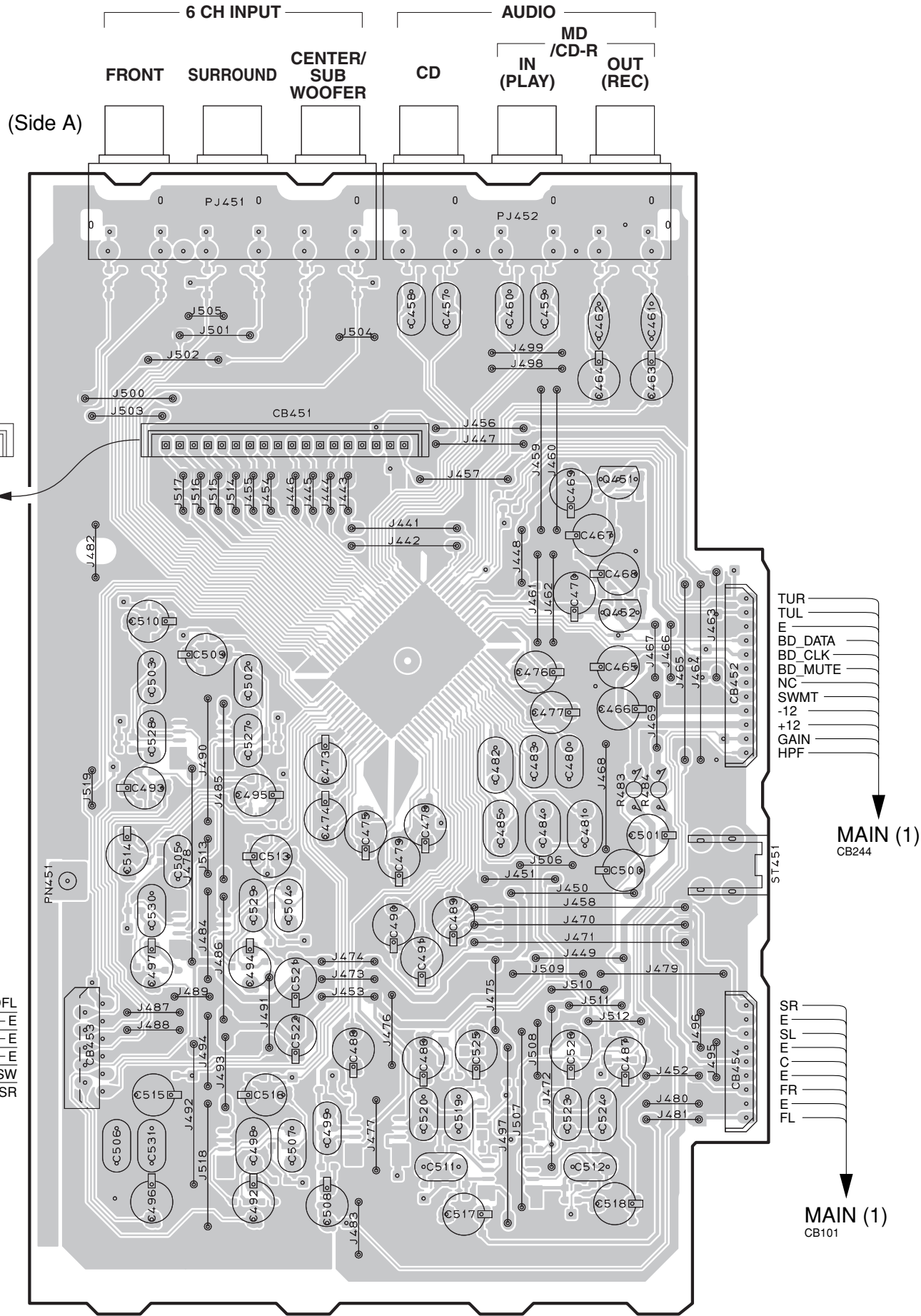

FUNCTION (1) P. C. B. (Side B)

Lead Free Solder Used

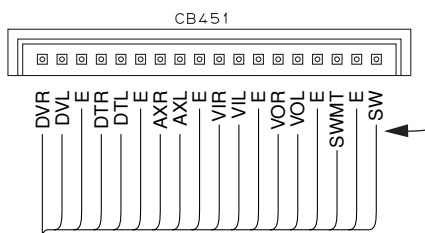
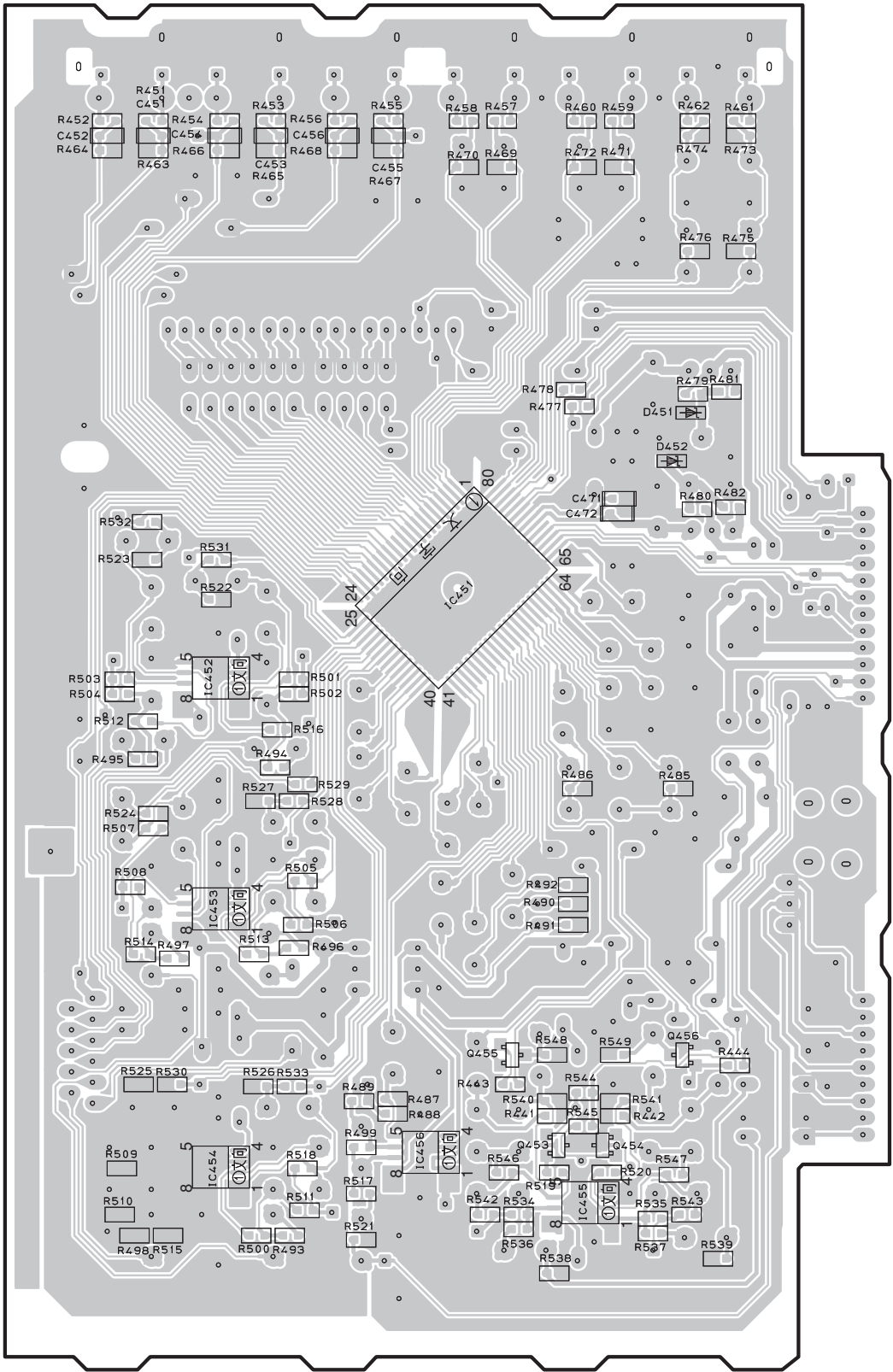

FUNCTION (6) CB677

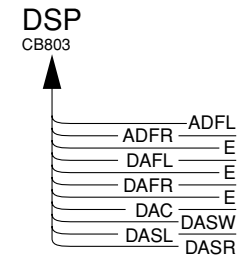

• Semiconductor Location

Ref. no.	Location
D451	I3
D452	I4
IC451	I4
IC452	H5
IC453	H5
IC454	H6
IC455	I7
IC456	H6
Q451	E3
Q452	E4
Q453	I6
Q454	I6
Q455	I6
Q456	I6

1 ■ PRINTED CIRCUIT BOARD (Foil side)

FUNCTION (2) P. C. B. (Side A)

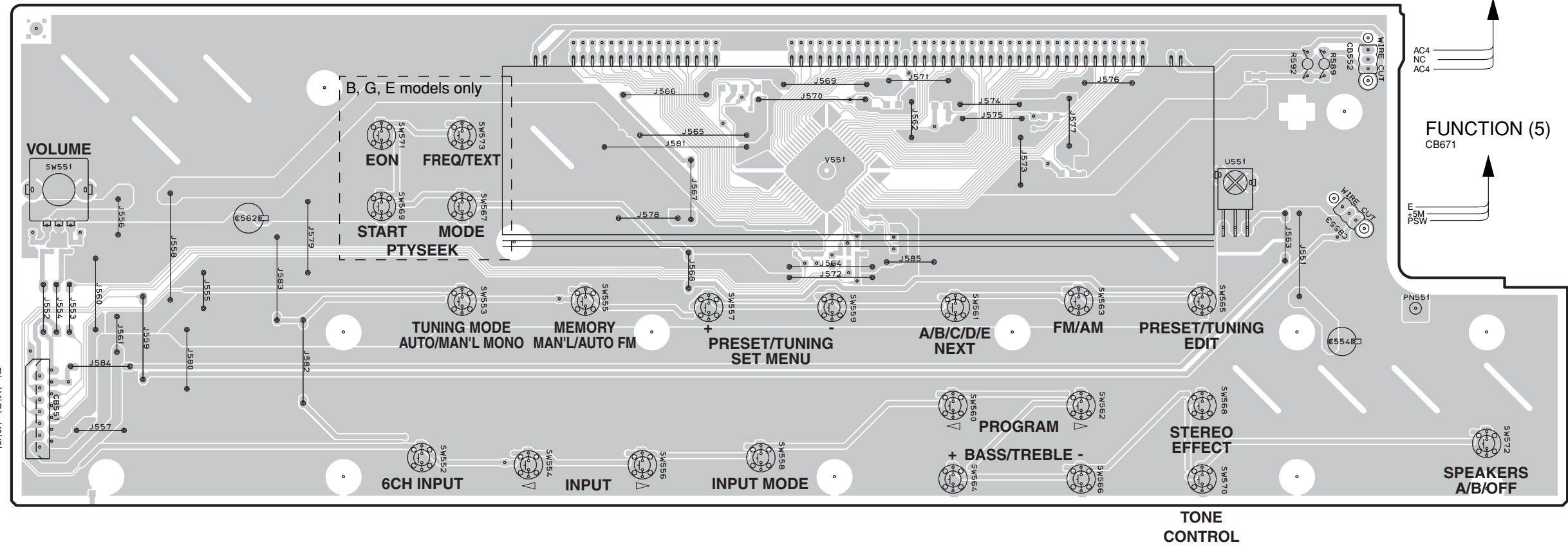

FUNCTION (4)
CB653

FUNCTION (5)
CB671

FUNCTION (2) P. C. B. (Side B) Lead Free Solder Used

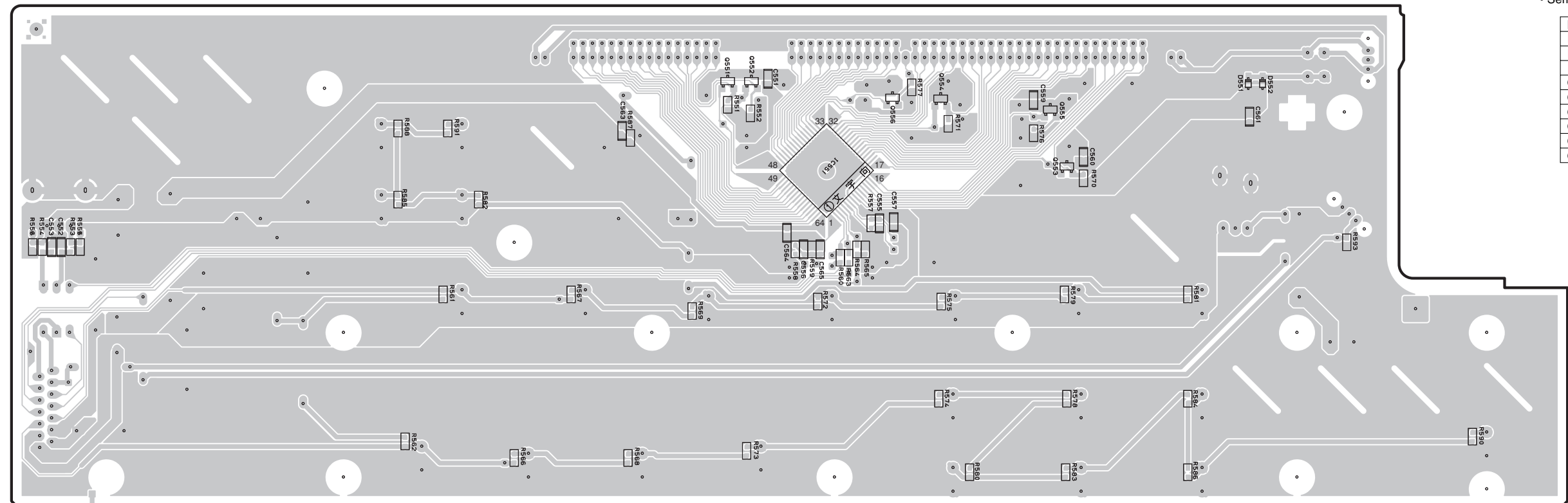

• Semiconductor Location

Ref. no.	Location
D551	H5
D552	H5
IC551	F5
Q551	E5
Q552	F5
Q553	G5
Q554	G5
Q555	G5
Q556	F5

PRINTED CIRCUIT BOARD (Foil side)

FUNCTION (3) P. C. B. (Side A)

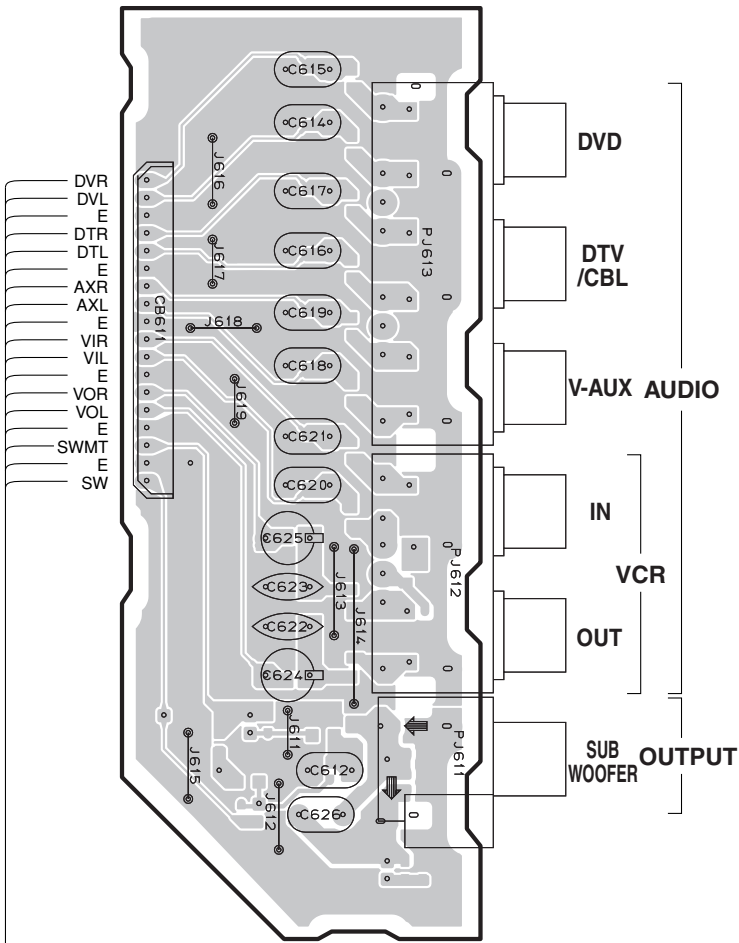

FUNCTION (3) P. C. B. (Side B)

Lead Free Solder Used

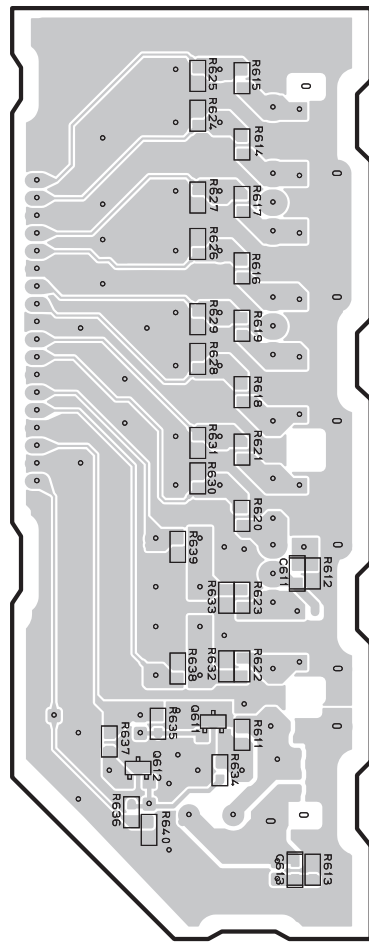

FUNCTION (4) P. C. B. (Side A)

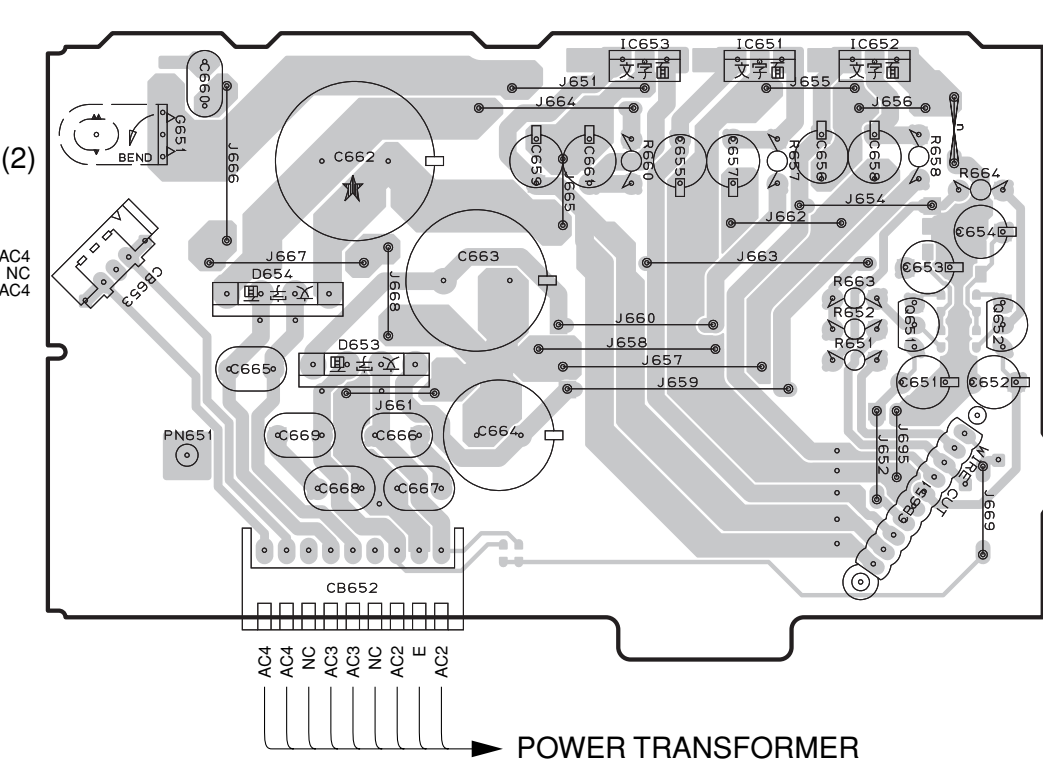

FUNCTION (4) P. C. B. (Side B)

Lead Free Solder Used

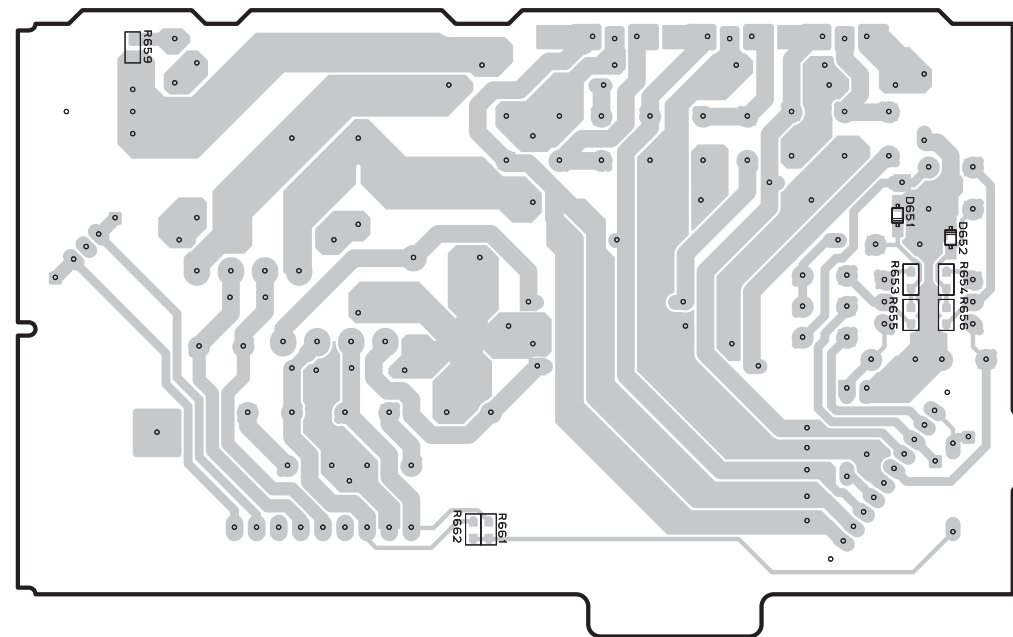

FUNCTION (5) P. C. B. (Side A)

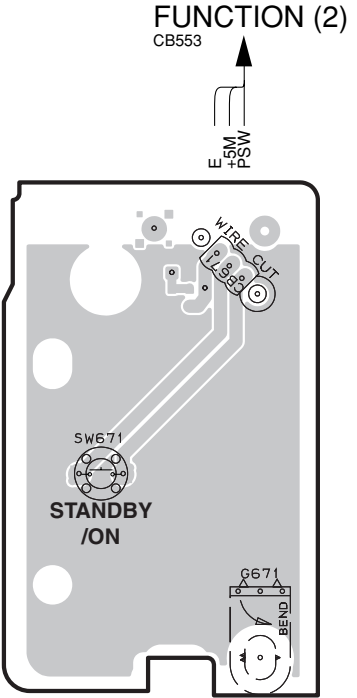

FUNCTION (5) P. C. B. (Side B)

Lead Free Solder Used

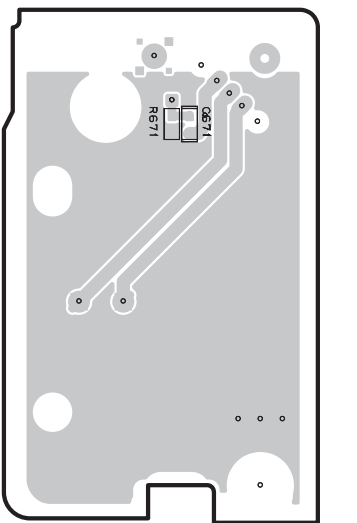

FUNCTION (6) P. C. B. (Side B) Lead Free Solder Used

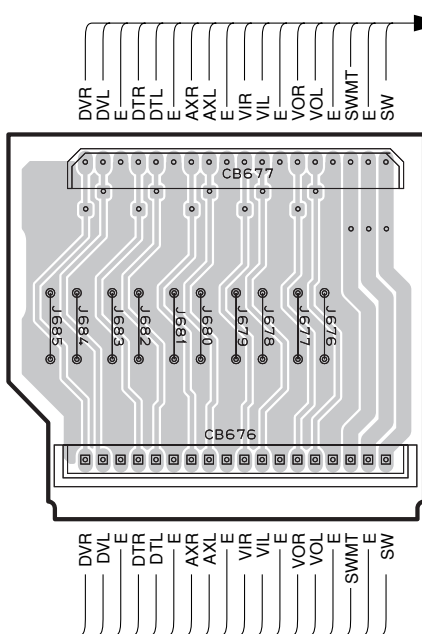

FUNCTION (1) CB451

• Semiconductor Location

Ref. no.	Location
D651	H5
D652	H5
D653	F3
D654	F2
IC651	H2
IC652	H2
IC653	G2
Q611	D4
Q612	D4

1 ■ PRINTED CIRCUIT BOARD (Foil side)

FUNCTION (7) P. C. B. (Side A)

R, L models

FUNCTION (8) P. C. B. (Side A)

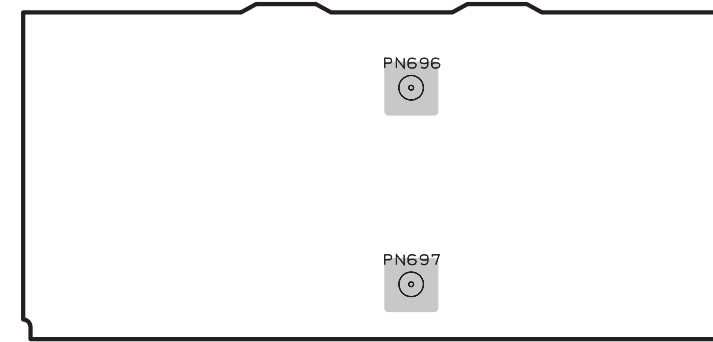
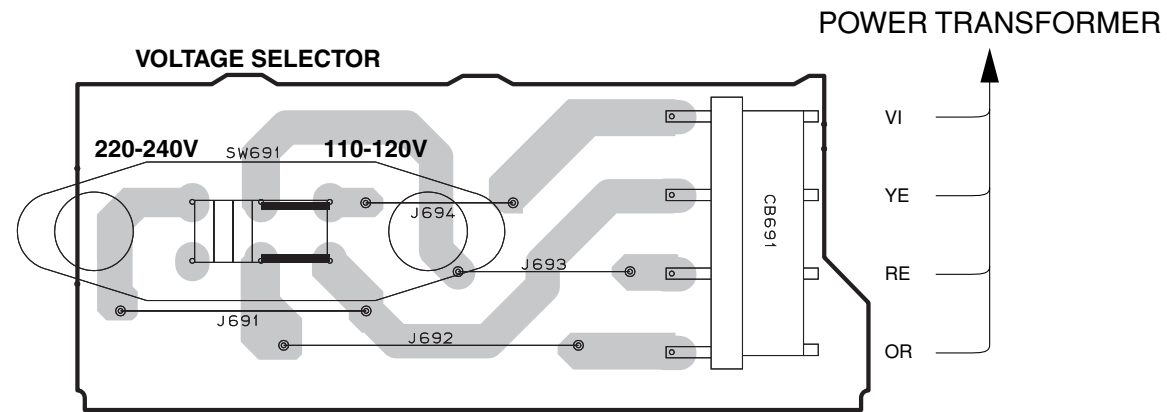

FUNCTION (9) P. C. B. (Side A)

FUNCTION (10) P. C. B. (Side A)

FUNCTION (10) P. C. B. (Side B)

Lead Free Solder Used

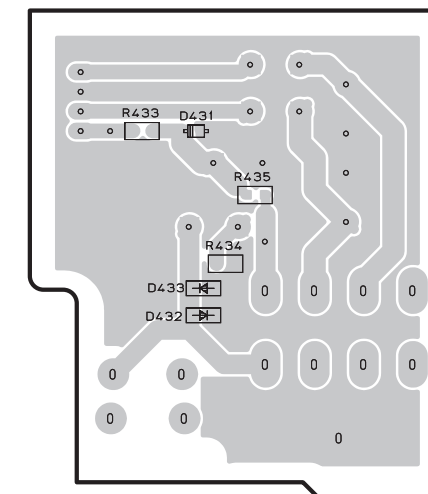
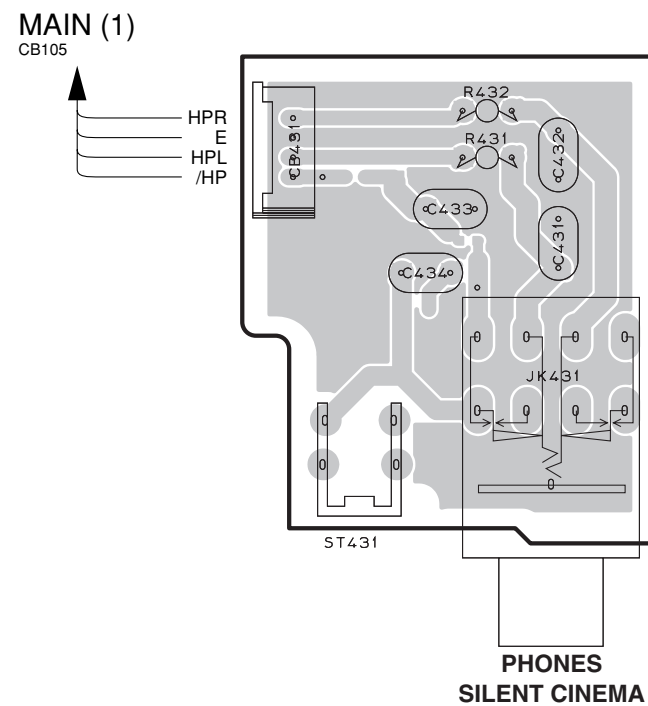
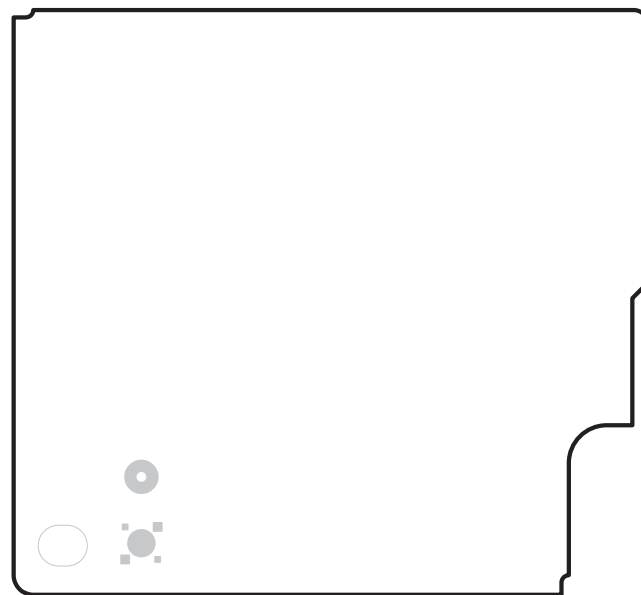

• Semiconductor Location

Ref. no.	Location
D431	H5
D432	H6
D433	H6

PRINTED CIRCUIT BOARD (Foil side)

MAIN (1) P. C. B. (Side A)

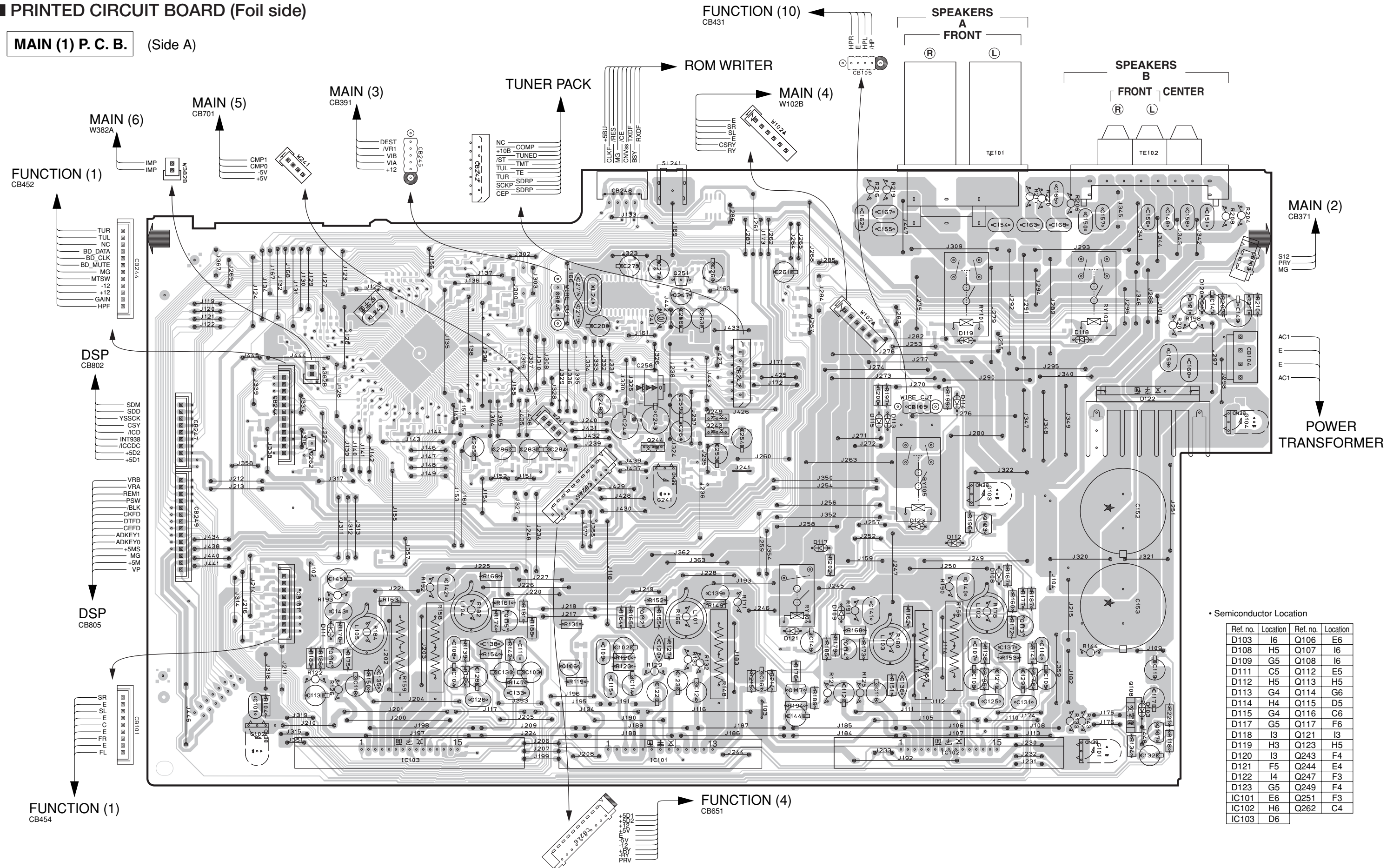

• Semiconductor Location

Ref. no.	Location	Ref. no.	Location
D103	I6	Q106	E6
D108	H5	Q107	I6
D109	G5	Q108	I6
D111	C5	Q112	E5
D112	H5	Q113	H5
D113	G4	Q114	G6
D114	H4	Q115	D5
D115	G4	Q116	C6
D117	G5	Q117	F6
D118	I3	Q121	I3
D119	H3	Q123	H5
D120	I3	Q243	F4
D121	F5	Q244	E4
D122	I4	Q247	F3
D123	G5	Q249	F4
IC101	E6	Q251	F3
IC102	H6	Q262	C4
IC103	D6		

1 ■ PRINTED CIRCUIT BOARD (Foil side)

MAIN (1) P. C. B. (Side B) Lead Free Solder Used

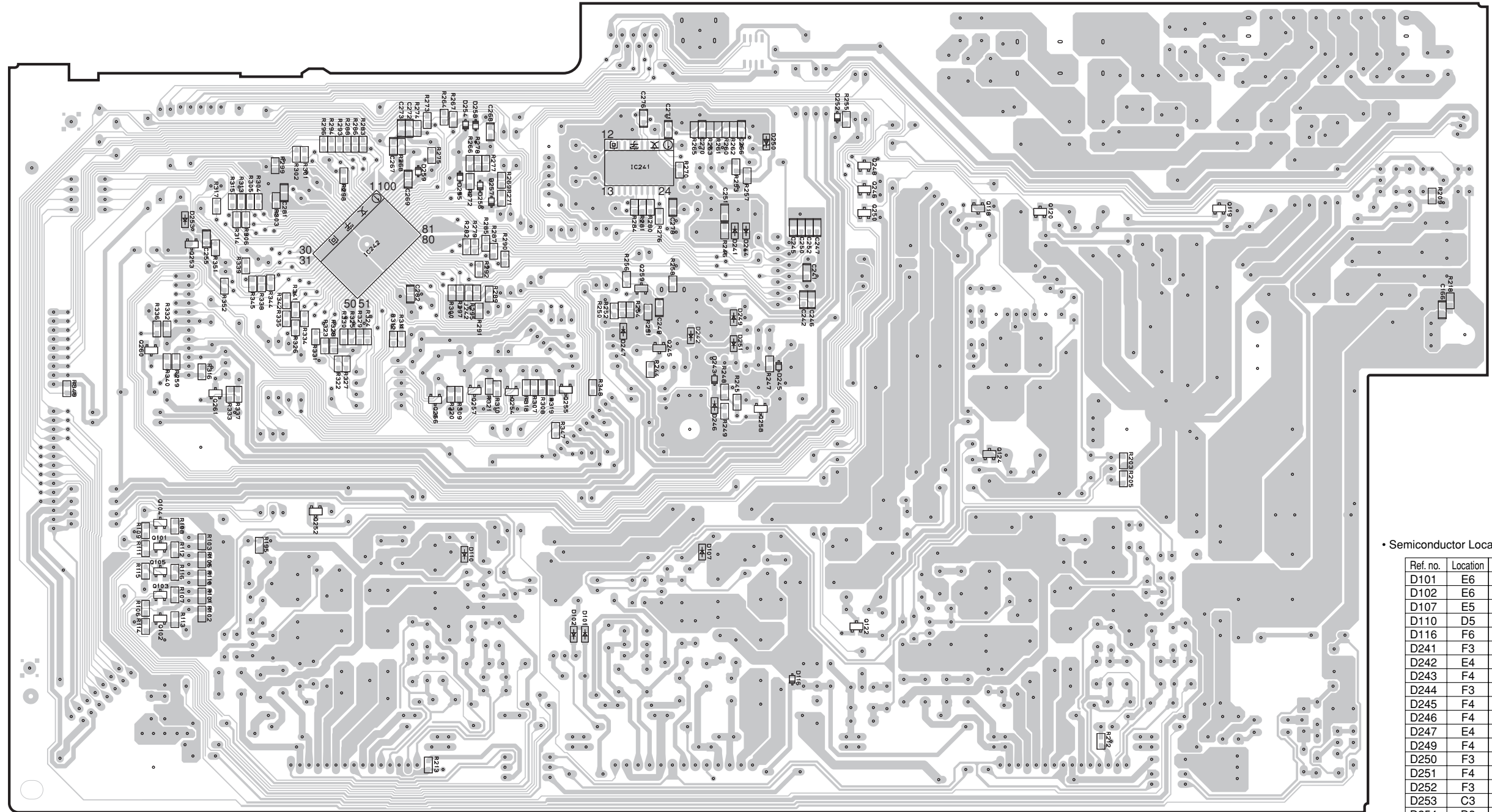

• Semiconductor Location

Ref. no.	Location	Ref. no.	Location
D101	E6	Q101	C5
D102	E6	Q102	C5
D107	E5	Q103	C5
D110	D5	Q104	C5
D116	F6	Q105	C5
D241	F3	Q118	G3
D242	E4	Q119	H3
D243	F4	Q120	G3
D244	F3	Q122	F6
D245	F4	Q124	G5
D246	F4	Q245	E4
D247	E4	Q246	F3
D249	F4	Q248	F3
D250	F3	Q250	F3
D251	F4	Q252	C5
D252	F3	Q253	C3
D253	C3	Q254	D4
D254	D3	Q255	E4
D255	D3	Q256	D4
D256	D3	Q257	D4
D257	D3	Q258	F4
D258	D3	Q259	E4
D259	D3	Q260	C4
IC241	E3	Q261	C4
IC242	D3		

PRINTED CIRCUIT BOARD (Foil side)

MAIN (2) P. C. B. (Side A)

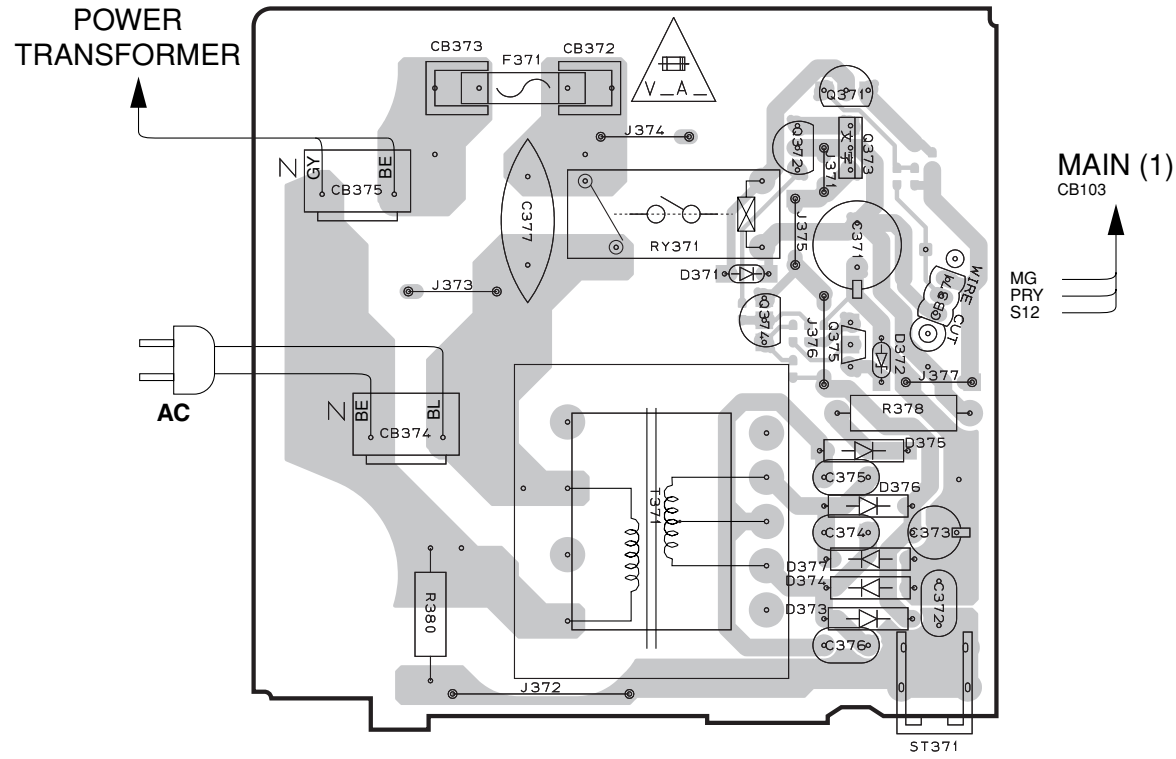

MAIN (3) P. C. B. (Side A)

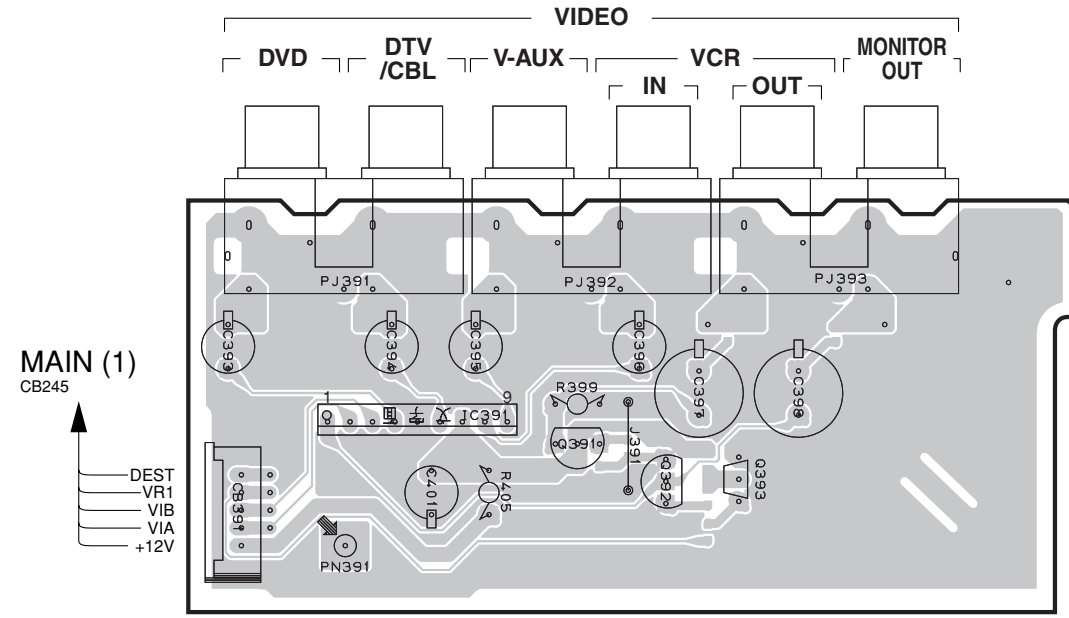

MAIN (4) P. C. B. (Side A)

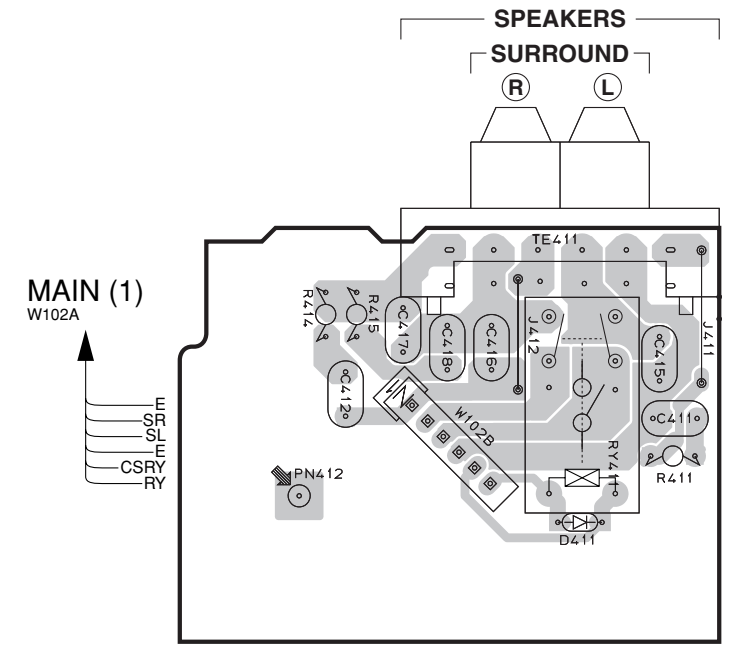

MAIN (2) P. C. B. (Side B) Lead Free Solder Used

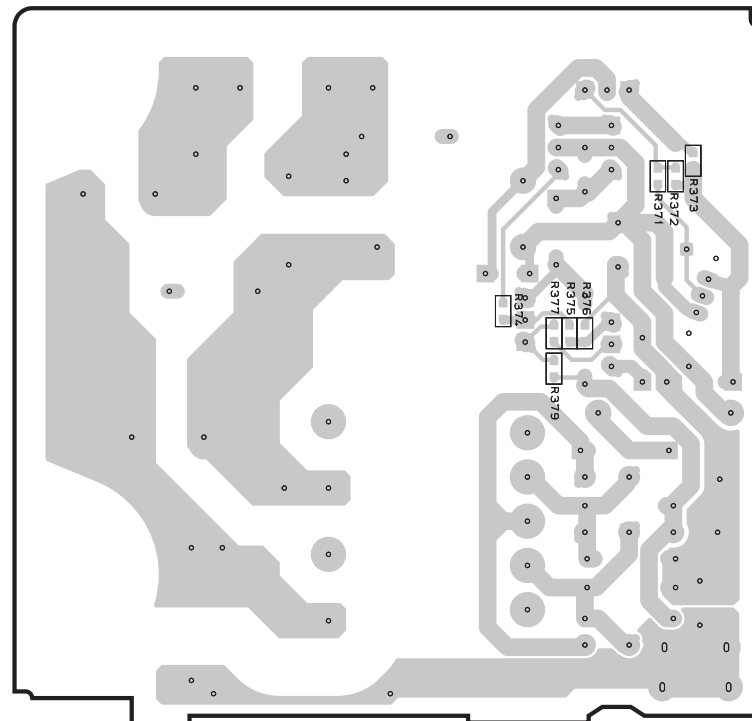

MAIN (3) P. C. B. (Side B) Lead Free Solder Used

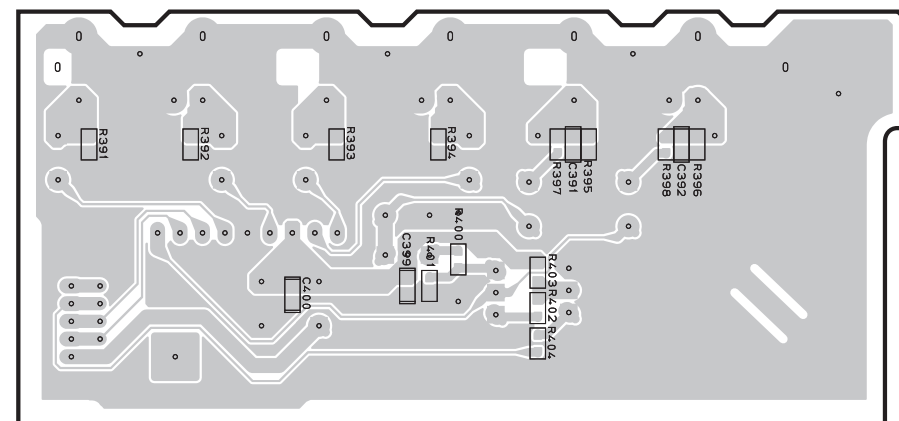

• Semiconductor Location

Ref. no.	Location
D371	C3
D372	D3
D373	D4
D374	D4
D375	D3
D376	D3
D377	D3
D411	J3
IC391	F3
Q371	D2
Q372	C2
Q373	D2
Q374	C3
Q375	D3
Q391	G3
Q392	G3
Q393	G3

1 ■ PRINTED CIRCUIT BOARD (Foil side)

MAIN (5) P. C. B. (Side A)

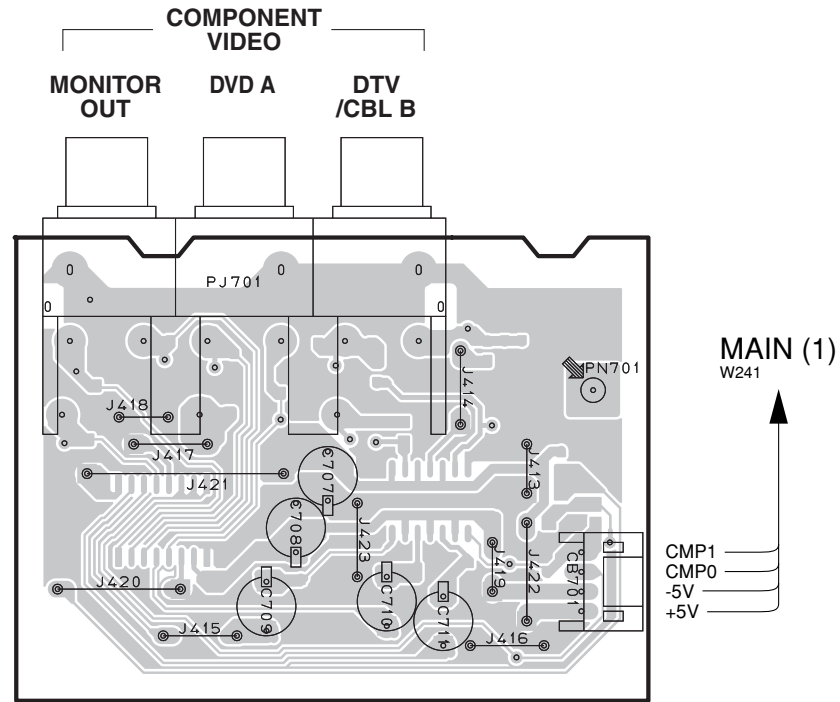

MAIN (6) P. C. B. (Side A)

U, C models

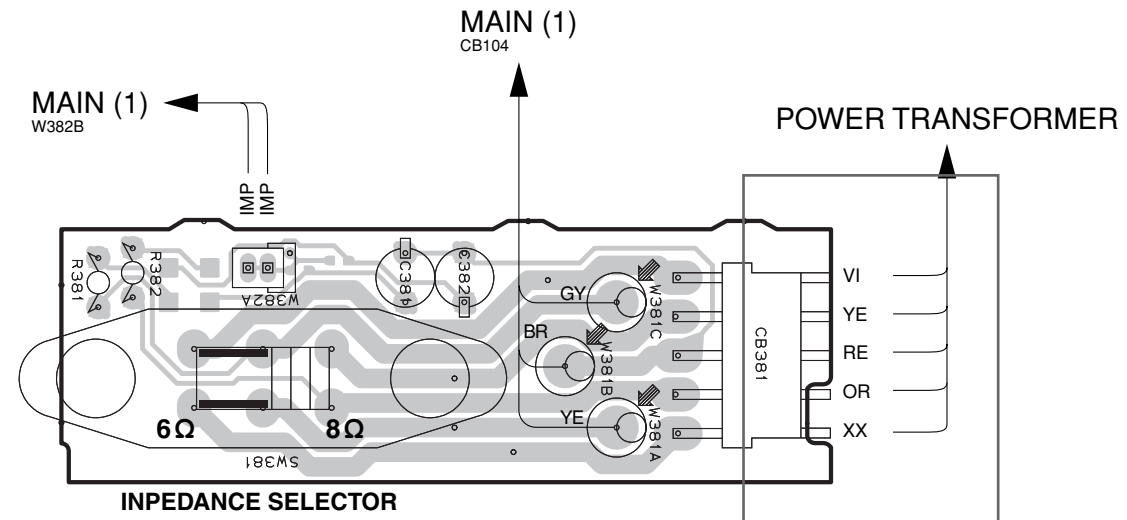

MAIN (5) P. C. B. (Side B) Lead Free Solder Used

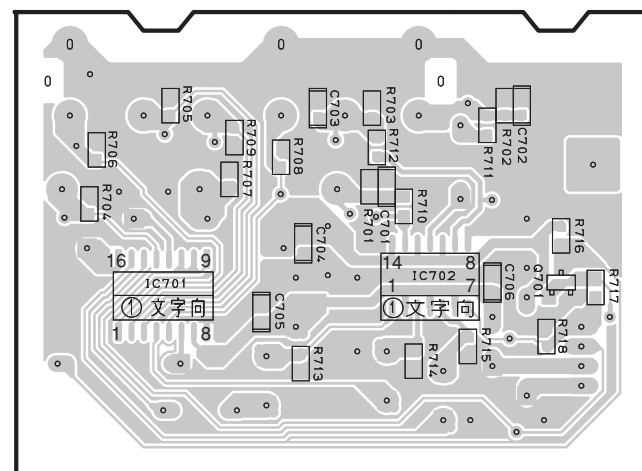

MAIN (6) P. C. B. (Side B) Lead Free Solder Used

U, C models

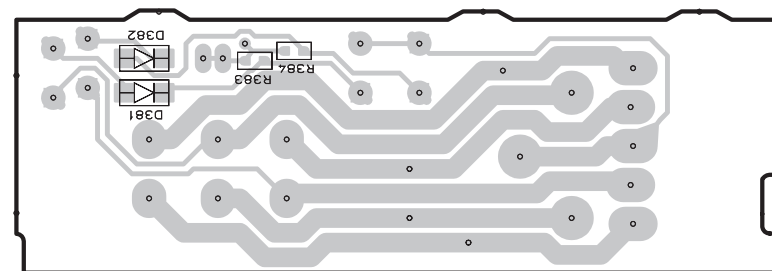

• Semiconductor Location

Ref. no.	Location
D381	F6
D382	F6
IC701	B6
IC702	C6
Q701	C6

Circuit No.	U, C	R	T	K	A	B, G, E	L
C148, 150, 162, 163, 411, 412	X	O	O	O	O	O	O
C154, 155, 156, 157, 415, 416, 418	X	X	X	O	O	O	O
C164, 165, 167, 168, 417	X	X	X	O	O	O	X
C274, 275, 277, 279, 280	X	X	X	X	X	O	X
C373, 375, 376	X	O	X	X	X	X	O
C374	O	X	O	O	O	O	X
C381, 382	O	X	X	X	X	X	X
CB381	O	X	X	X	X	X	X
D253, 381, 382	O	X	X	X	X	X	X
D372, 375	X	O	X	X	X	X	O
IC241	X	X	X	X	X	O	X
Q249, 372, 373, 374, 375	X	O	X	X	X	X	O
Q251	X	X	X	X	X	O	X
Q253	O	X	X	X	X	X	X
R204, 206, 216, 217, 411, 414	X	O	O	O	O	O	O
R219, 220, 415	X	X	X	O	O	O	O
R378	X	O	X	X	X	X	O
R380, 381, 382	O	X	X	X	X	X	X
R383, 384	O	X	X	X	X	X	X
SW381	O	X	X	X	X	X	X
XL241	X	X	X	X	X	O	X

X : NOT USED
O : USED / APPLICABLE

PIN CONNECTION DIAGRAM

• ICs

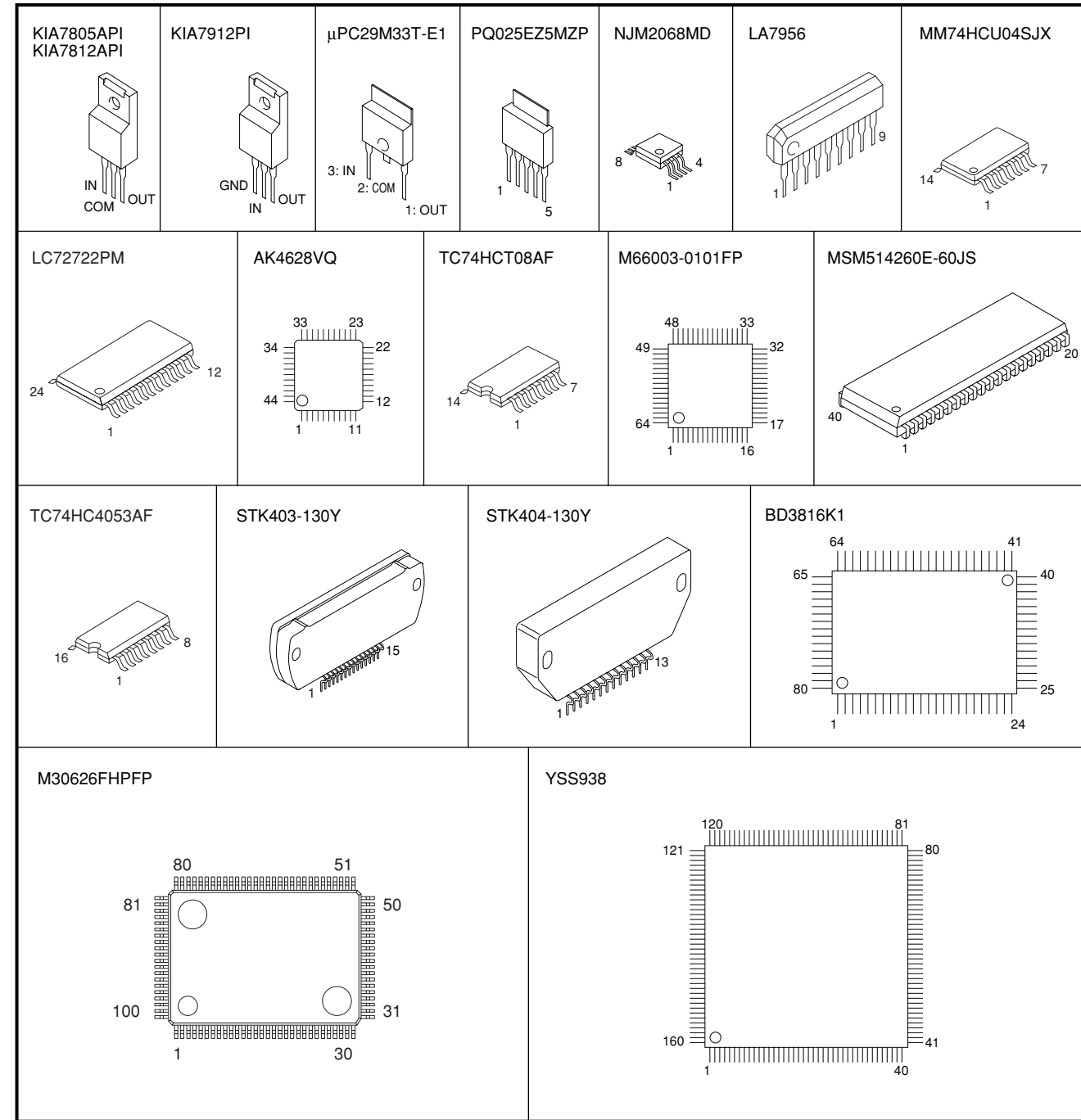

• Diodes

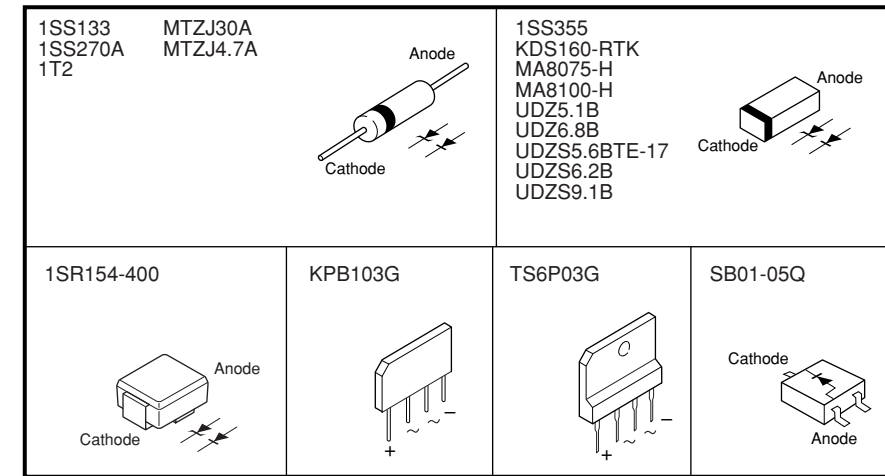

• Transistors

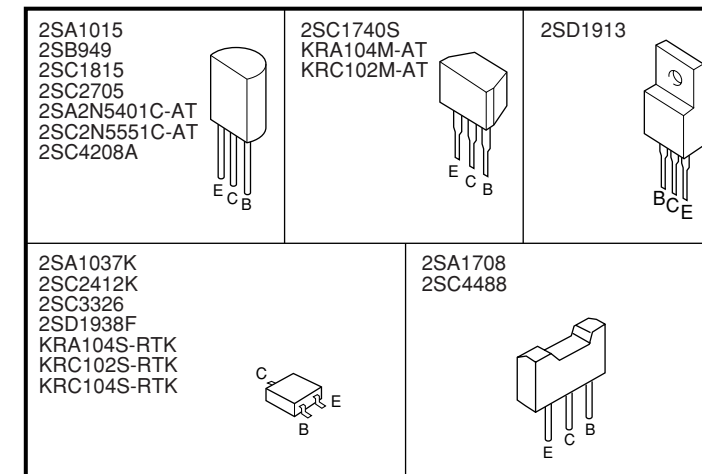

■ BLOCK DIAGRAM

1
2
3
4
5
6
7
8
9
10

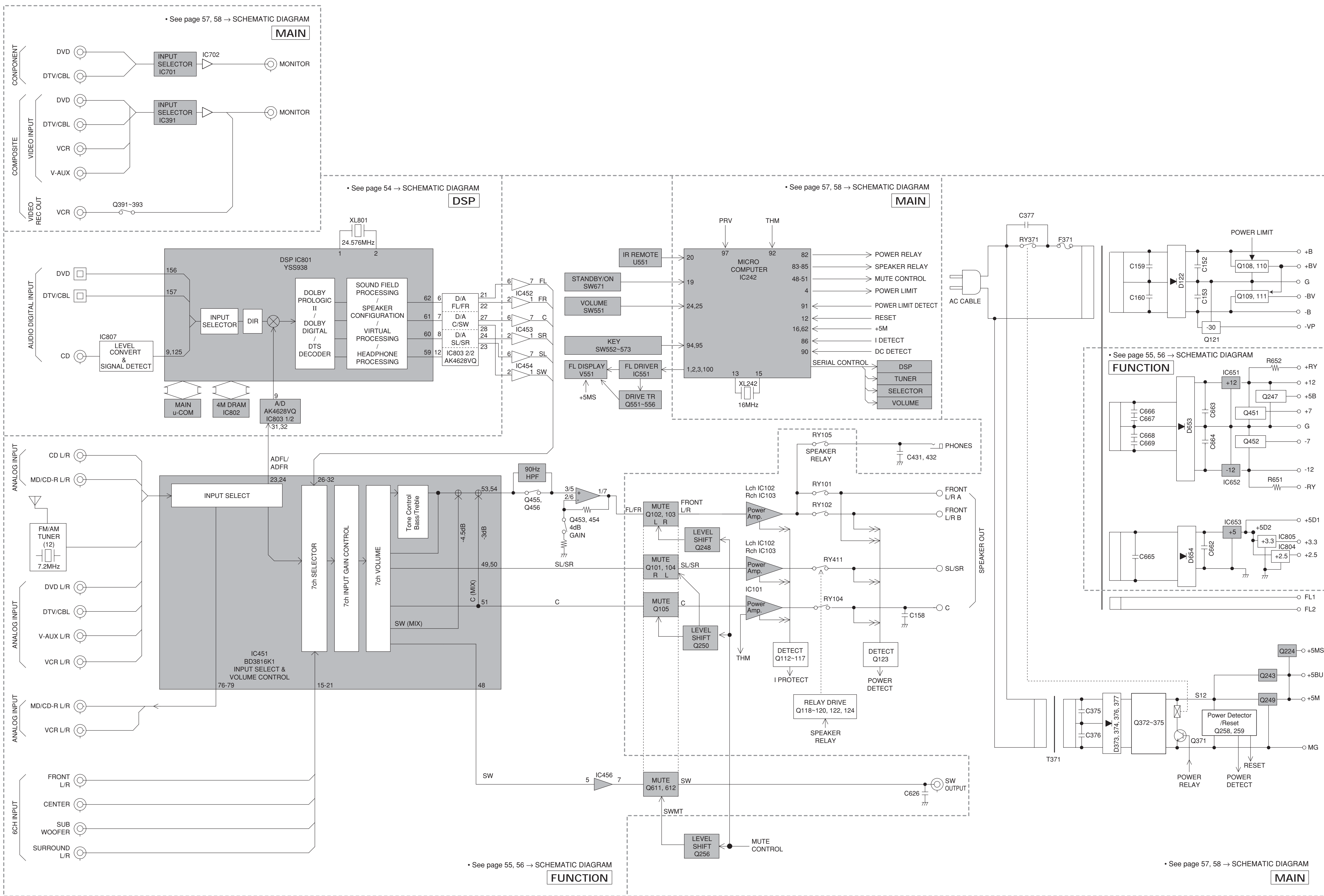

• See page 55, 56 → SCHEMATIC DIAGRAM

• See page 57, 58 → SCHEMATIC DIAGRAM

SCHEMATIC DIAGRAM (DSP)

RESISTOR	
REMARKS	PARTS NAME
NO MARK	CARBON FILM RESISTOR (P=5)
□	CARBON FILM RESISTOR (P=10)
△	METAL OXIDE FILM RESISTOR
▲	METAL FILM RESISTOR
⊠	METAL PLATE RESISTOR
⊞	FIRE PROOF CARBON FILM RESISTOR
⊞	CEMENT MOLDED RESISTOR
⊞	SEMI VARIABLE RESISTOR
⊞	CHIP RESISTOR

CAPACITOR	
REMARKS	PARTS NAME
NO MARK	ELECTROLYTIC CAPACITOR
⊞	TANTALUM CAPACITOR
NO MARK	CERAMIC CAPACITOR
⊞	CERAMIC TUBULAR CAPACITOR
⊞	POLYESTER FILM CAPACITOR
⊞	POLYSTYRENE FILM CAPACITOR
⊞	POLYPROPYLENE FILM CAPACITOR
⊞	SEMICONDUCTIVE CERAMIC CAPACITOR
⊞	POLYPHENYLENE SULFIDE FILM CAPACITOR

Interchangeable Parts at Manufacture-Stage

Mark	Reference Parts Number	Parts Name
K1	IC802	MSM514260E-60J5 GL144016E-40J4 IC41C16267-36K IC41C16267-60K1 M18M16266A-35J A4263165-25
K2	UB01-802	GP1FA553RZ T501179
K3	IC807	MM74HC04SJK TC74HC04AF-1P1
K4	IC806	TC74HC108AF MM74HC108SJK
K5	DB01-806	1S5355 M4111

NOTICE (mode1)
 (J)..... JAPAN
 (U)..... U.S.A
 (C)..... CANADA
 (R)..... GENERAL
 (T)..... CHINA
 (K)..... KOREA
 (A)..... AUSTRALIA
 (B)..... BRITISH
 (G)..... EUROPE
 (L)..... SINGAPORE
 (E)..... SOUTH EUROPE
 (V)..... TAIWAN

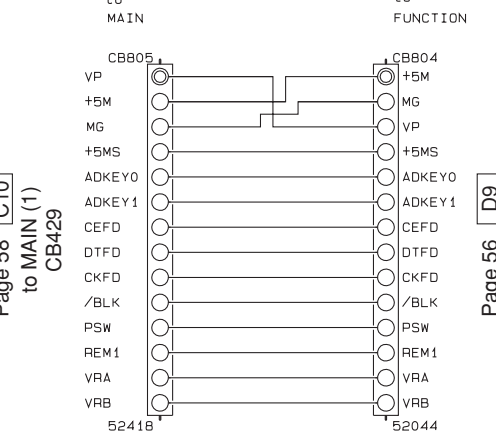
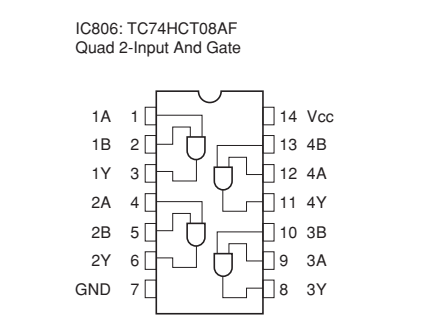
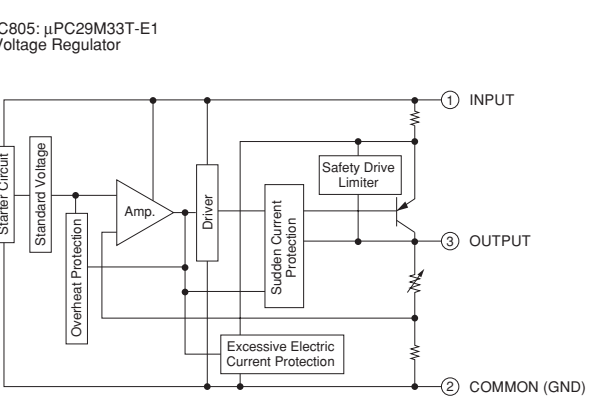
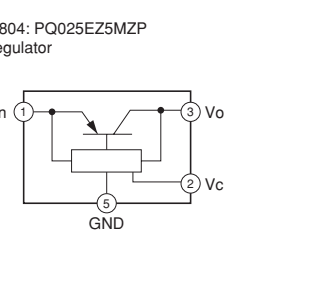
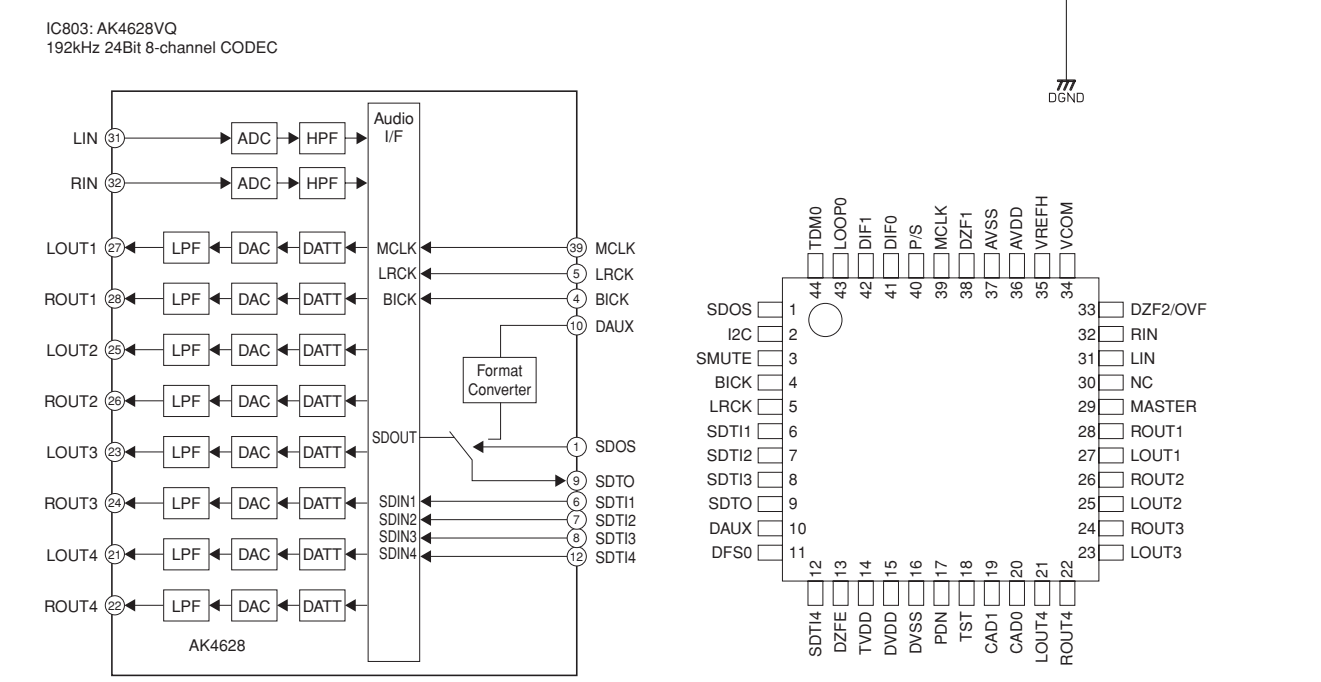
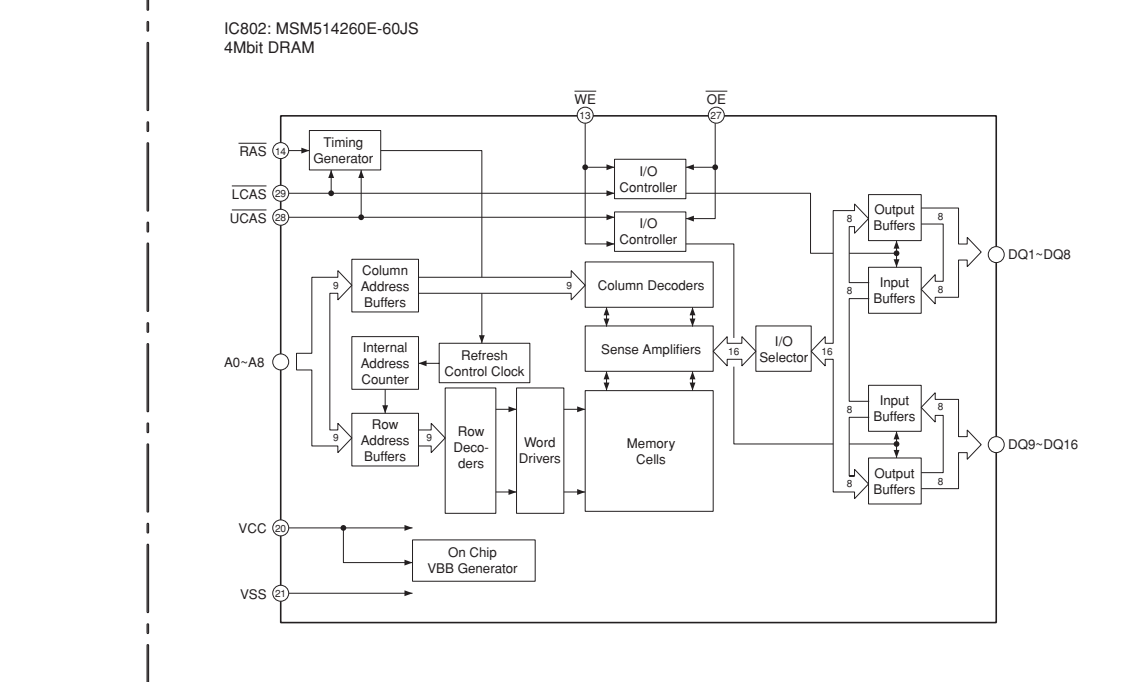
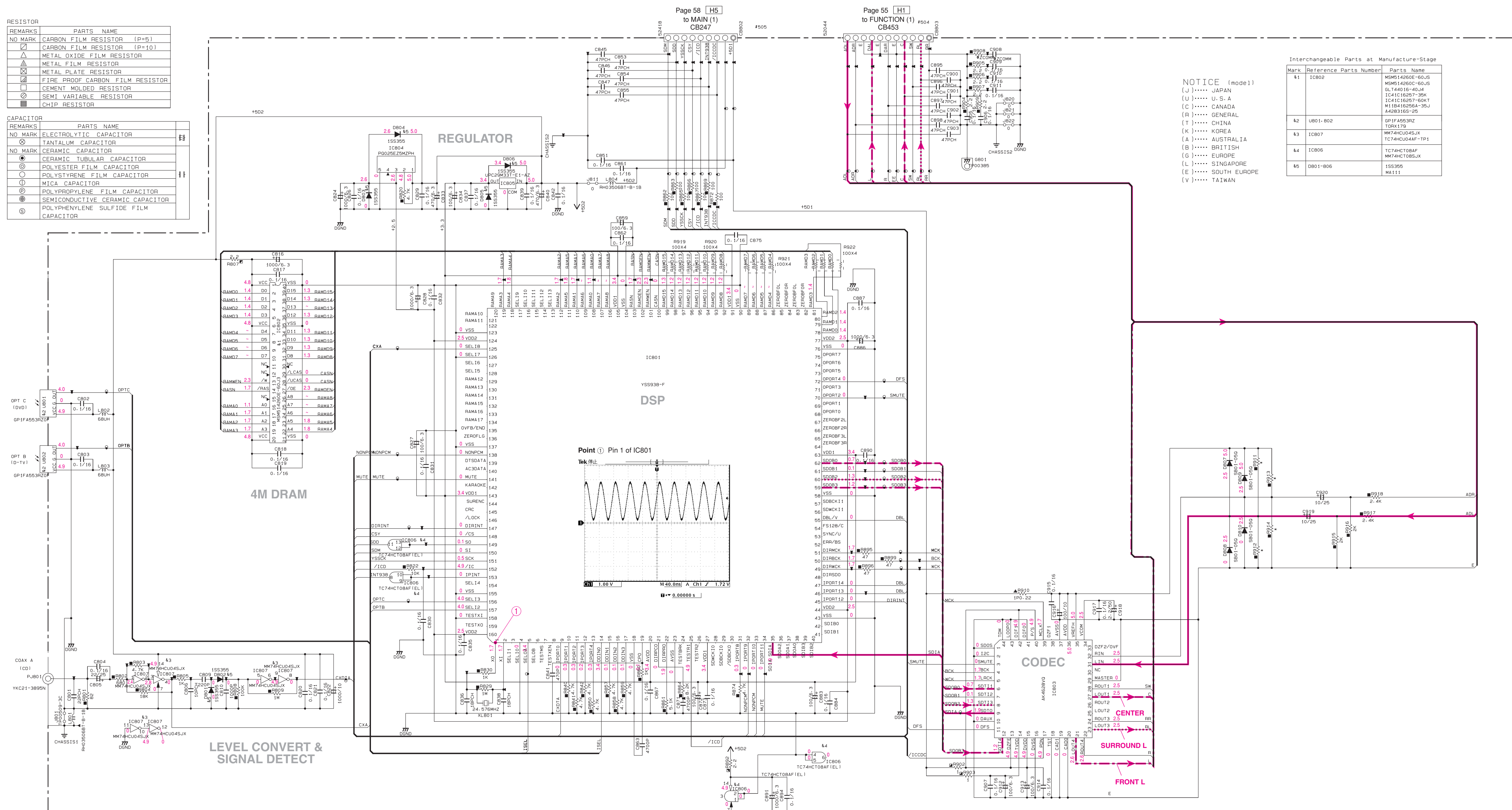

DSP

* All voltages are measured with a 10MΩ/V DC electronic volt meter.
 * Components having special characteristics are marked '!' and must be replaced with parts having specifications equal to those originally installed.
 * Schematic diagram is subject to change without notice.

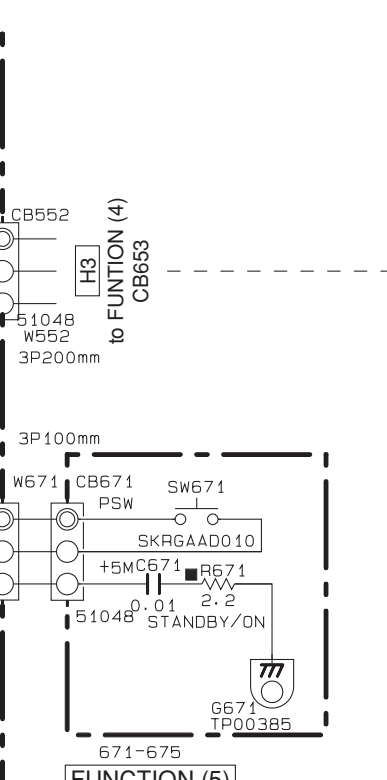
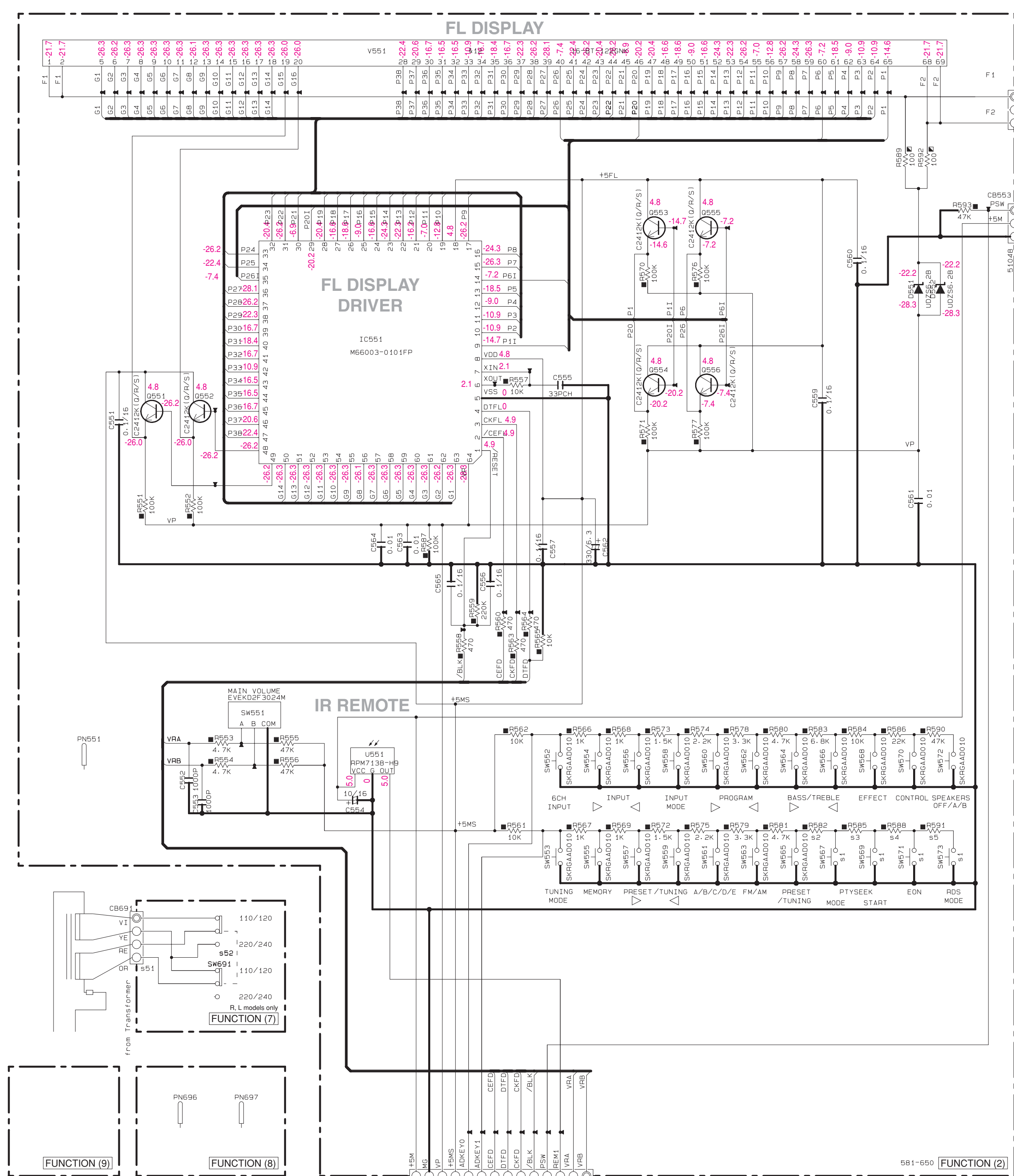

RESISTOR

REMARKS	PARTS NAME
NO MARK	CARBON FILM RESISTOR (P=5)
NO MARK	CARBON FILM RESISTOR (P=10)
△	METAL OXIDE FILM RESISTOR
▲	METAL FILM RESISTOR
⊠	METAL PLATE RESISTOR
⊞	FIRE PROOF CARBON FILM RESISTOR
□	CEMENT MOLDED RESISTOR
⊕	SEMI VARIABLE RESISTOR
■	CHIP RESISTOR

CAPACITOR

REMARKS	PARTS NAME
NO MARK	ELECTROLYTIC CAPACITOR
⊗	TANTALUM CAPACITOR
NO MARK	CERAMIC CAPACITOR
⊙	CERAMIC TUBULAR CAPACITOR
⊚	POLYESTER FILM CAPACITOR
○	POLYSTYRENE FILM CAPACITOR
○	MICA CAPACITOR
○	POLYPROPYLENE FILM CAPACITOR
⊙	SEMICONDUCTIVE CERAMIC CAPACITOR
⊙	POLYPHENYLENE SULFIDE FILM CAPACITOR

	U-C T, K, A	R, L	B, G, E
s1	SW567, 569, 571, 573	X	X
s2	R582	X	X
s3	R585	X	X
s4	R588	X	X
s5	R591	X	X
s52	SW691	X	X
s51	CB691	X	X

Interchangeable Parts at Manufacture-Stage

Mark	Reference Parts Number	Parts Name
&11	D653, 654	KBP103G RS103
&12	V551	16-BT-122GNK HNA-16MM46
&13	D432, 433	1S5355 MA111
&14	0652	2SA1015(Y) KTA1266(Y)

NOTICE (mode1)
 (J)..... JAPAN
 (U)..... U. S. A
 (C)..... CANADA
 (R)..... GENERAL
 (T)..... CHINA
 (K)..... KOREA
 (A)..... AUSTRALIA
 (B)..... BRITISH
 (G)..... EUROPE
 (L)..... SINGAPORE
 (E)..... SOUTH EUROPE
 (V)..... TAIWAN

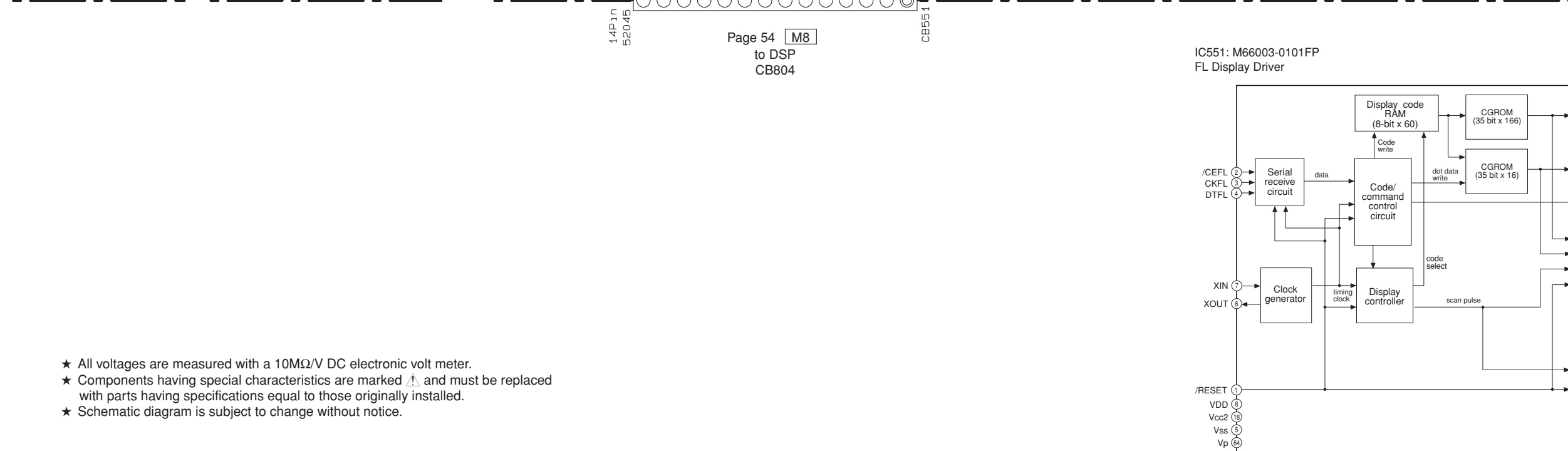
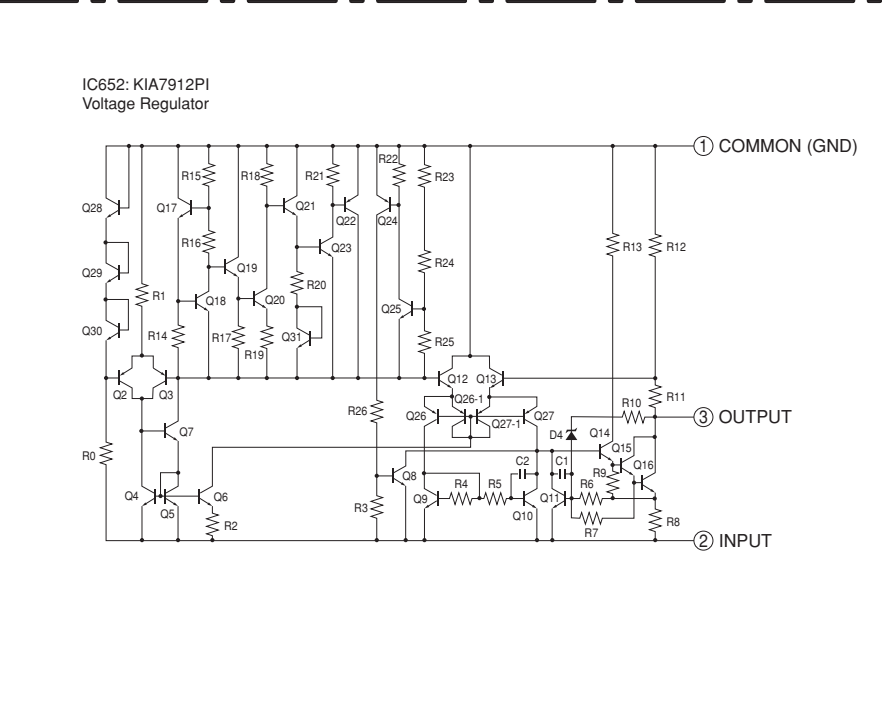
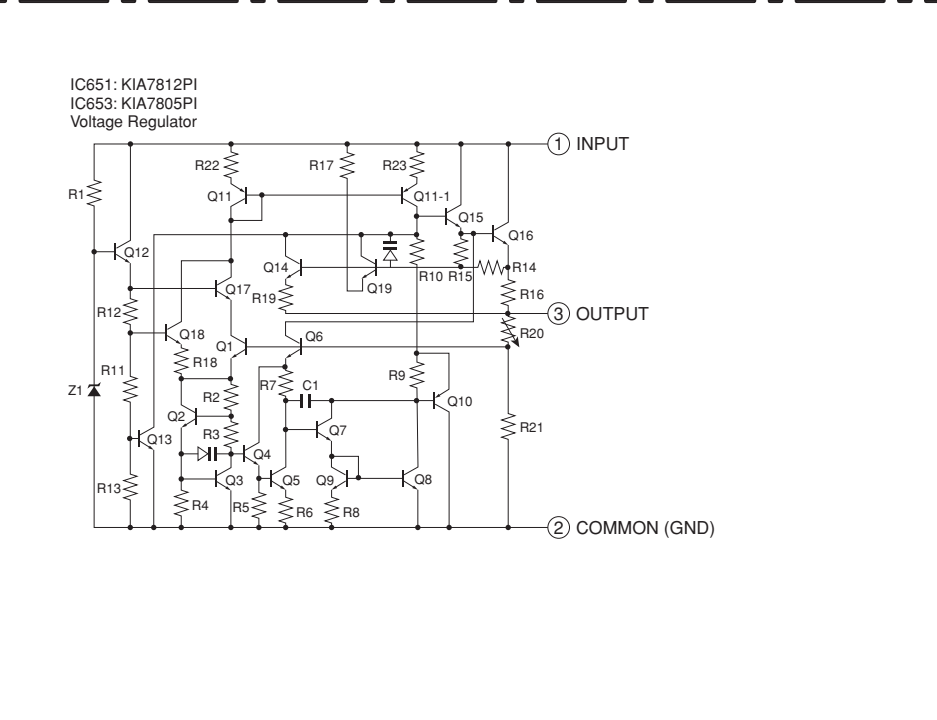
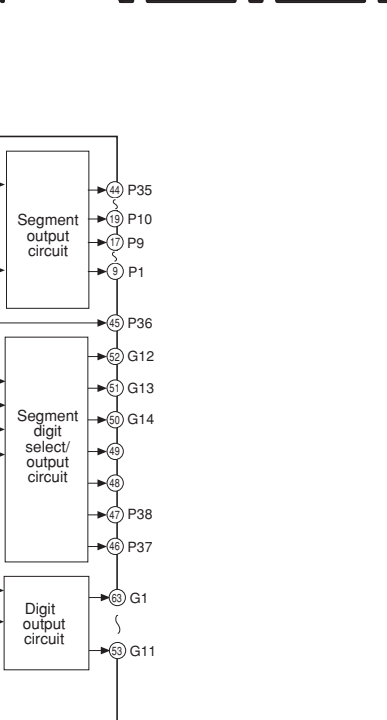
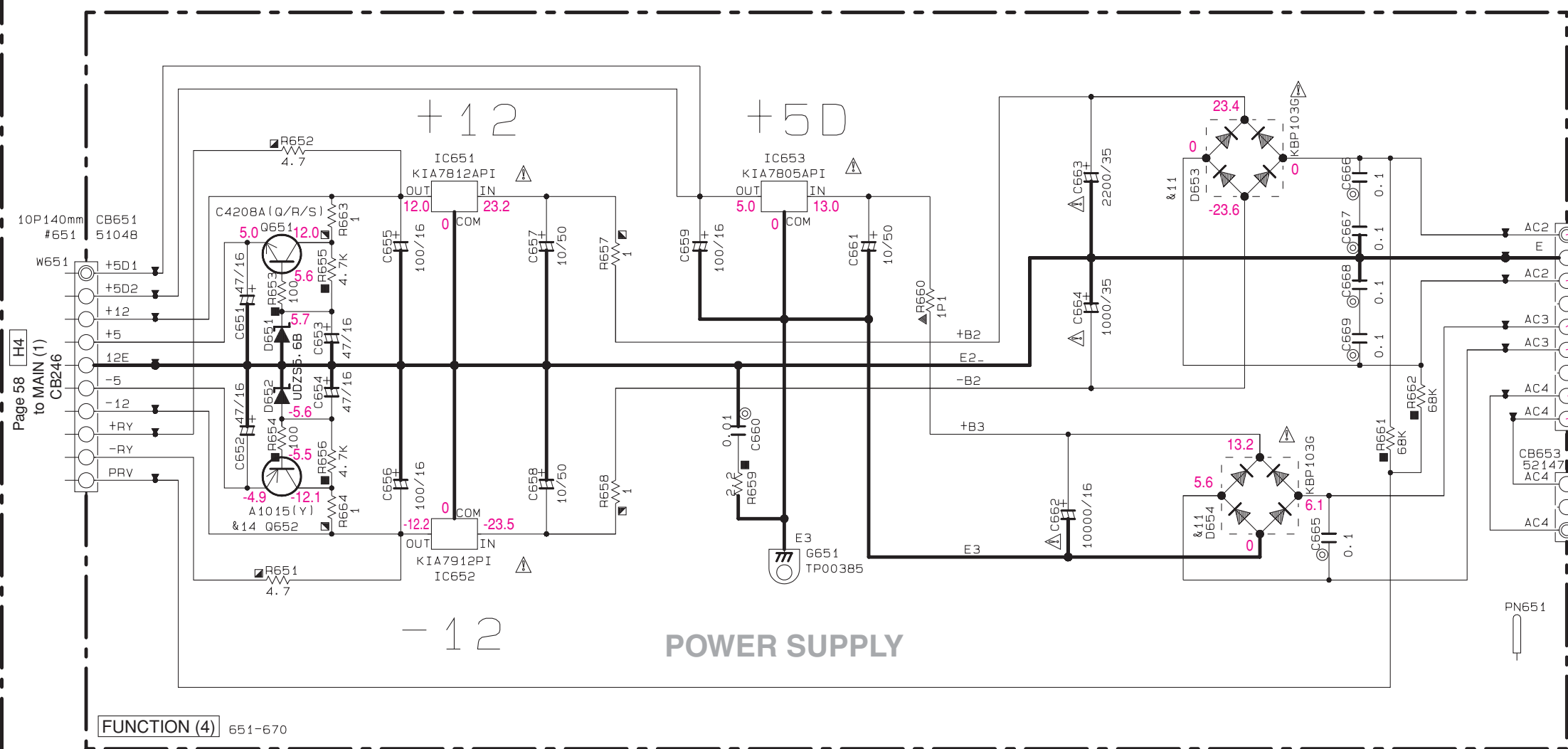
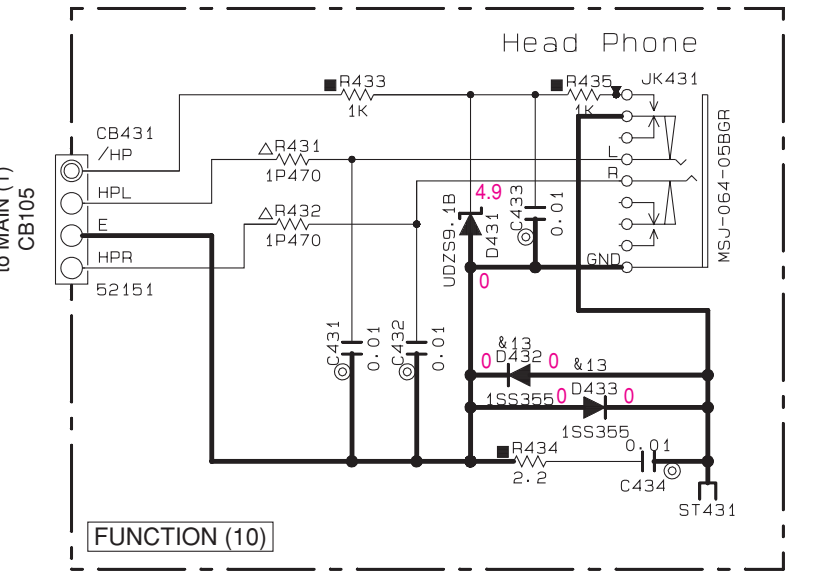

* All voltages are measured with a 10MΩ/V DC electronic volt meter.
 * Components having special characteristics are marked with a triangle and must be replaced with parts having specifications equal to those originally installed.
 * Schematic diagram is subject to change without notice.

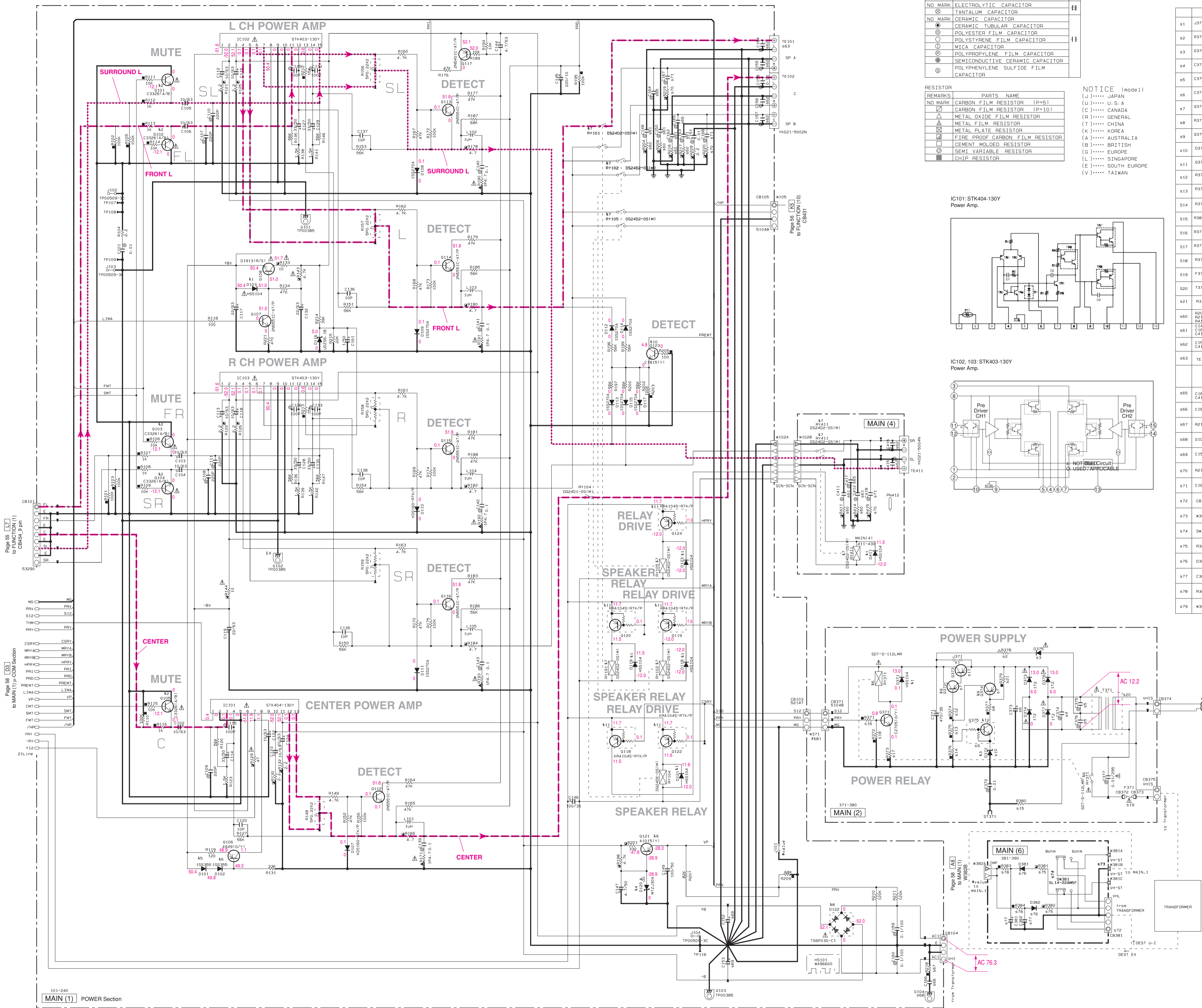

CAPACITOR

REMARKS	PARTS NAME
NO MARK	ELECTROLYTIC CAPACITOR
⊗	TANTALUM CAPACITOR
⊙	CERAMIC CAPACITOR
⊚	CERAMIC TUBULAR CAPACITOR
○	POLYESTER FILM CAPACITOR
⊖	POLYSTYRENE FILM CAPACITOR
⊕	MICA CAPACITOR
⊗	DOLBYPROPYLENE FILM CAPACITOR
⊚	SEMICONDUCTIVE CERAMIC CAPACITOR
⊖	POLYPHENYLENE SULFIDE FILM CAPACITOR

RESISTOR

REMARKS	PARTS NAME
NO MARK	CARBON FILM RESISTOR (P=5)
⊖	CARBON FILM RESISTOR (P=10)
⊕	METAL OXIDE FILM RESISTOR
⊗	METAL FILM RESISTOR
⊚	METAL PATE RESISTOR
⊖	FIRE PROOF CARBON FILM RESISTOR
⊚	CEMENT MOLDED FILM RESISTOR
⊖	SEMI VARIABLE RESISTOR
⊚	CHIP RESISTOR

NOTICE (model)
 (J)..... JAPAN
 (U)..... U.S.A
 (C)..... CANADA
 (R)..... GENERAL
 (T)..... CHINA
 (K)..... KOREA
 (A)..... AUSTRALIA
 (B)..... BRITISH
 (G)..... EUROPE
 (L)..... SINGAPORE
 (E)..... SOUTH EUROPE
 (V)..... TAIWAN

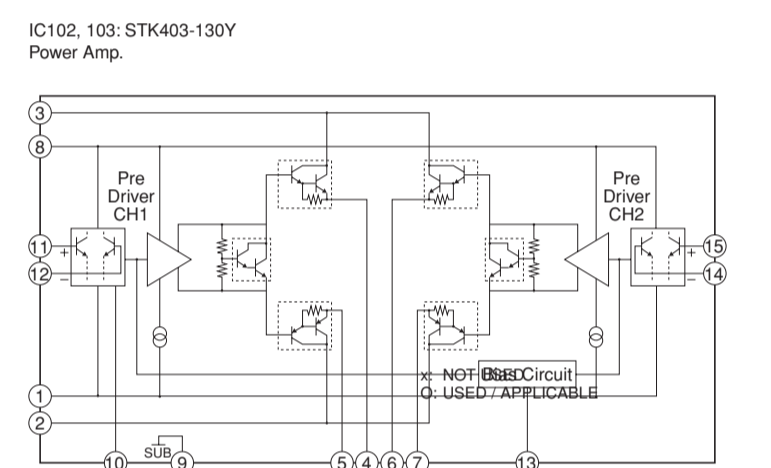
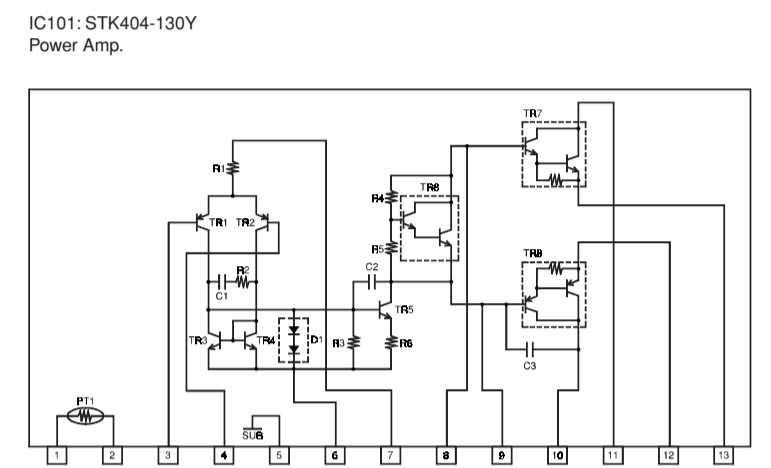

	U-C	R	T	A	K	B-G-E	L
51	J371	0	0	0	0	0	X
52	R378	X	X	X	X	X	X
53	D376	X	X	X	X	X	X
54	C374	0.01	0.01	0.01	0.01	0.01	X
55	C375-376	X	0.01	0.01	X	X	X
56	C373	X	10/100	10/100	X	X	X
57	G372-374	X	41051V1	41051V1	X	X	X
58	R377	X	47K	47K	X	X	X
59	G375	X	KRC102M-AT	KRC102M-AT	X	X	X
60	G372	X	MT2J4.7A	MT2J4.7A	X	X	X
61	G373	X	A17081S/11	A17081S/11	X	X	X
62	R374	X	1K	1K	X	X	X
63	R375	X	33K	33K	X	X	X
64	R376	X	5.6K	5.6K	X	X	X
65	R380	1/200-2M	X	X	X	X	X
66	R371	4.7K	RD35647	4.7K	RD35647	4.7K	RD35618
67	R373	0	RD35000	0	RD35000	0	RD35000
68	R372	100K	RD35610	100K	RD35610	100K	RD35610
69	F371	6A125V	6A125V	13.15A1250V	13.15A1250V	13.15A1250V	6A125V
70	T371	XW974	XW974	X4278	X4278	X4278	XW974
71	R379	X	100K	X	X	X	X
72	R204-206	X	2.2	2.2	2.2	2.2	2.2
73	R211-214	X	HV75322	HV75322	HV75322	HV75322	HV75322
74	C148-150	X	0.01	0.01	0.01	0.01	0.01
75	C151-153	X	UA65410	UA65410	UA65410	UA65410	UA65410
76	C154-157	X	UA65410	UA65410	UA65410	UA65410	UA65410
77	C158-163	X	UA65410	UA65410	UA65410	UA65410	UA65410
78	C164-166	X	X	X	X	X	X
79	C167	X	X	X	X	X	X
80	C168	X	X	X	X	X	X
81	C169	X	X	X	X	X	X
82	C170	X	X	X	X	X	X
83	C171	X	X	X	X	X	X
84	C172	X	X	X	X	X	X
85	C173	X	X	X	X	X	X
86	C174	X	X	X	X	X	X
87	C175	X	X	X	X	X	X
88	C176	X	X	X	X	X	X
89	C177	X	X	X	X	X	X
90	C178	X	X	X	X	X	X
91	C179	X	X	X	X	X	X
92	C180	X	X	X	X	X	X
93	C181	X	X	X	X	X	X
94	C182	X	X	X	X	X	X
95	C183	X	X	X	X	X	X
96	C184	X	X	X	X	X	X
97	C185	X	X	X	X	X	X
98	C186	X	X	X	X	X	X
99	C187	X	X	X	X	X	X
100	C188	X	X	X	X	X	X
101	C189	X	X	X	X	X	X
102	C190	X	X	X	X	X	X
103	C191	X	X	X	X	X	X
104	C192	X	X	X	X	X	X
105	C193	X	X	X	X	X	X
106	C194	X	X	X	X	X	X
107	C195	X	X	X	X	X	X
108	C196	X	X	X	X	X	X
109	C197	X	X	X	X	X	X
110	C198	X	X	X	X	X	X
111	C199	X	X	X	X	X	X
112	C200	X	X	X	X	X	X
113	C201	X	X	X	X	X	X
114	C202	X	X	X	X	X	X
115	C203	X	X	X	X	X	X
116	C204	X	X	X	X	X	X
117	C205	X	X	X	X	X	X
118	C206	X	X	X	X	X	X
119	C207	X	X	X	X	X	X
120	C208	X	X	X	X	X	X
121	C209	X	X	X	X	X	X
122	C210	X	X	X	X	X	X
123	C211	X	X	X	X	X	X
124	C212	X	X	X	X	X	X
125	C213	X	X	X	X	X	X
126	C214	X	X	X	X	X	X
127	C215	X	X	X	X	X	X
128	C216	X	X	X	X	X	X
129	C217	X	X	X	X	X	X
130	C218	X	X	X	X	X	X
131	C219	X	X	X	X	X	X
132	C220	X	X	X	X	X	X
133	C221	X	X	X	X	X	X
134	C222	X	X	X	X	X	X
135	C223	X	X	X	X	X	X
136	C224	X	X	X	X	X	X
137	C225	X	X	X	X	X	X
138	C226	X	X	X	X	X	X
139	C227	X	X	X	X	X	X
140	C228	X	X	X	X	X	X
141	C229	X	X	X	X	X	X
142	C230	X	X	X	X	X	X
143	C231	X	X	X	X	X	X
144	C232	X	X	X	X	X	X
145	C233	X	X	X	X	X	X
146	C234	X	X	X	X	X	X
147	C235	X	X	X	X	X	X
148	C236	X	X	X	X	X	X
149	C237	X	X	X	X	X	X
150	C238	X	X	X	X	X	X
151	C239	X	X	X	X	X	X
152	C240	X	X	X	X	X	X
153	C241	X	X	X	X	X	X
154	C242	X	X	X	X	X	X
155	C243	X	X	X	X	X	X
156	C244	X	X	X	X	X	X
157	C245	X	X	X	X	X	X
158	C246	X	X	X	X	X	X
159	C247	X	X	X	X	X	X
160	C248	X	X	X	X	X	X
161	C249	X	X	X	X	X	X
162	C250	X	X	X	X	X	X
163	C251	X	X	X	X	X	X
164	C252	X	X	X	X	X	X
165	C253	X	X	X	X	X	X
166	C254	X	X	X	X	X	X
167	C255	X	X	X	X	X	X
168	C256	X	X	X	X	X	X
169	C257	X	X	X	X	X	X
170	C258	X	X	X	X	X	X
171	C259	X	X	X	X	X	X
172	C260	X	X	X	X	X	X
173	C261	X	X	X	X	X	X
174	C262	X	X	X	X	X	X
175	C263	X	X	X	X	X	X
176	C264	X	X	X	X	X	X
177	C265	X	X	X	X	X	X
178	C266	X	X	X	X	X	X
179	C267	X	X	X	X	X	X
180	C268	X	X	X	X	X	X
181	C269	X	X	X	X	X	X
182	C270	X	X	X	X	X	X
183	C271	X	X	X	X	X	X
184	C272	X	X	X	X	X	X
185	C273	X	X	X	X	X	X
186	C274	X	X	X	X	X	X
187	C275	X	X	X	X	X	X
188	C276	X	X	X	X	X	X
189	C277	X	X	X	X	X	X
190	C278	X	X	X	X	X	X
191	C279	X	X	X	X	X	X
192	C280	X	X	X	X	X	X
193	C281	X	X	X	X	X	X
194	C282	X	X	X	X	X	X
195	C283	X	X	X	X	X	X
196	C284	X	X	X	X	X	X
197	C285	X	X	X	X	X	X
198	C286	X	X	X	X	X	X
199	C287	X	X	X	X	X	X
200	C288	X	X	X	X	X	X

Interchangeable Parts at Manufacture-Stage

Mark	Reference Parts Number	Parts Name
51	D103, 118, 119, 121, 123, 371, 411	H55104 155133 155176
42	G101-105	25C33261A/B1 25C33261B1 25C5938A1A/B1
43	G372	MT2J4.7A
44	D120	MT2J30A GDZJ30A
45	D101-102	155355 M4111
46	RV371	S01-5-112LMR D01001-01M1-11 AL43321 G5P4-1-B
47	RV101-102-105-111	DS2402-051M G5P4-2-B
48	D122	T56P030-C1 R5603M
49	G121-372-374	25A10151V1 K7A12661V1
410	G123	25C1810151V1 K7C131981V1
411	G118-120-122-124	KR41045-RTK DT1444EKA
412	G375	KRC102M-AT DTC114ES

* All voltages are measured with a 10M Ω /V DC electronic volt meter.
 * Components having special characteristics are marked Δ , and must be replaced with parts having specifications equal to those originally installed.
 * Schematic diagram is subject to change without notice.

PARTS LIST

■ ELECTRICAL PARTS

■ WARNING

- Components having special characteristics are marked  and must be replaced with parts having specifications equal to those originally installed.

ABBREVIATIONS IN THIS LIST ARE AS FOLLOWS:

C.A.EL.CHP	: CHIP ALUMI.ELECTROLYTIC CAP	L.EMIT	: LIGHT EMITTING MODULE
C.CE	: CERAMIC CAP	LED.DSPLY	: LED DISPLAY
C.CE.ARRAY	: CERAMIC CAP ARRAY	LED.INFRD	: LED,INFRARED
C.CE.CHP	: CHIP CERAMIC CAP	MODUL.RF	: MODULATOR,RF
C.CE.ML	: MULTILAYER CERAMIC CAP	PHOT.CPL	: PHOTO COUPLER
C.CE.M.CHP	: CHIP MULTILAYER CERAMIC CAP	PHOT.INTR	: PHOTO INTERRUPTER
C.CE.SAFTY	: RECOGNIZED CERAMIC CAP	PHOT.RFLCT	: PHOTO REFLECTOR
C.CE.TUBLR	: CERAMIC TUBULAR CAP	PIN.TEST	: PIN,TEST POINT
C.CE.SMI	: SEMI CONDUCTIVE CERAMIC CAP	PLST.RIVET	: PLASTIC RIVET
C.EL	: ELECTROLYTIC CAP	R.ARRAY	: RESISTOR ARRAY
C.MICA	: MICA CAP	R.CAR.	: CARBON RESISTOR
C.ML.FLM	: MULTILAYER FILM CAP	R.CAR.CHP	: CHIP RESISTOR
C.MP	: METALLIZED PAPER CAP	R.CAR.FP	: FLAME PROOF CARBON RESISTOR
C.MYLAR	: MYLAR FILM CAP	R.FUS	: FUSABLE RESISTOR
C.MYLAR.ML	: MULTILAYER MYLAR FILM CAP	R.MTL.CHP	: CHIP METAL FILM RESISTOR
C.PAPER	: PAPER CAPACITOR	R.MTL.FLM	: METAL FILM RESISTOR
C.PLS	: POLYSTYRENE FILM CAP	R.MTL.OXD	: METAL OXIDE FILM RESISTOR
C.POL	: POLYESTER FILM CAP	R.MTL.PLAT	: METAL PLATE RESISTOR
C.POLY	: POLYETHYLENE FILM CAP	RSNR.CE	: CERAMIC RESONATOR
C.PP	: POLYPROPYLENE FILM CAP	RSNR.CRYS	: CRYSTAL RESONATOR
C.TNTL	: TANTALUM CAP	R.TW.CEM	: TWIN CEMENT FIXED RESISTOR
C.TNTL.CHP	: CHIP TANTALUM CAP	R.WW	: WIRE WOUND RESISTOR
C.TRIM	: TRIMMER CAP	SCR.BND.HD	: BIND HEAD B-TITE SCREW
CN	: CONNECTOR	SCR.BW.HD	: BW HEAD TAPPING SCREW
CN.BS.PIN	: CONNECTOR,BASE PIN	SCR.CUP	: CUP TITE SCREW
CN.CANNON	: CONNECTOR,CANNON	SCR.TERM	: SCREW TERMINAL
CN.DIN	: CONNECTOR,DIN	SCR.TR	: SCREW,TRANSISTOR
CN.FLAT	: CONNECTOR,FLAT CABLE	SUPRT.PCB	: SUPPORT,P.C.B.
CN.POST	: CONNECTOR,BASE POST	SURG.PRTCT	: SURGE PROTECTOR
COIL.MX.AM	: COIL,AM MIX	SW.TACT	: TACT SWITCH
COIL.AT.FM	: COIL,FM ANTENNA	SW.LEAF	: LEAF SWITCH
COIL.DT.FM	: COIL,FM DETECT	SW.LEVER	: LEVER SWITCH
COIL.MX.FM	: COIL,FM MIX	SW.MICRO	: MICRO SWITCH
COIL.OUTPT	: OUTPUT COIL	SW.PUSH	: PUSH SWITCH
DIOD.ARRAY	: DIODE ARRAY	SW.RT.ENC	: ROTARY ENCODER
DIODE.BRG	: DIODE BRIDGE	SW.RT.MTR	: ROTARY SWITCH WITH MOTOR
DIODE.CHP	: CHIP DIODE	SW.RT	: ROTARY SWITCH
DIODE.VAR	: VARACTOR DIODE	SW.SLIDE	: SLIDE SWITCH
DIOD.Z.CHP	: CHIP ZENER DIODE	TERM.SP	: SPEAKER TERMINAL
DIODE.ZENR	: ZENER DIODE	TERM.WRAP	: WRAPPING TERMINAL
DSCR.CE	: CERAMIC DISCRIMINATOR	THRMST.CHP	: CHIP THERMISTOR
FER.BEAD	: FERRITE BEADS	TR.CHP	: CHIP TRANSISTOR
FER.CORE	: FERRITE CORE	TR.DGT	: DIGITAL TRANSISTOR
FET.CHP	: CHIP FET	TR.DGT.CHP	: CHIP DIGITAL TRANSISTOR
FL.DSPLY	: FLUORESCENT DISPLAY	TRANS	: TRANSFORMER
FLTR.CE	: CERAMIC FILTER	TRANS.PULS	: PULSE TRANSFORMER
FLTR.COMB	: COMB FILTER MODULE	TRANS.PWR	: POWER TRANSFORMER ASS'Y
FLTR.LC.RF	: LC FILTER,EMI	TUNER.AM	: TUNER PACK,AM
GND.MTL	: GROUND PLATE	TUNER.FM	: TUNER PACK,FM
GND.TERM	: GROUND TERMINAL	TUNER.PK	: FRONT-ENDTUNER PACK
HOLDER.FUS	: FUSE HOLDER	VR	: ROTARY POTENTIOMETER
IC.PRTCT	: IC PROTECTOR	VR.MTR	: POTENTIOMETER WITH MOTOR
JUMPER.CN	: JUMPER CONNECTOR	VR.SW	: POTENTIOMETER WITH ROTARY SW
JUMPER.TST	: JUMPER,TEST POINT	VR.SLIDE	: SLIDE POTENTIOMETER
L.DTCT	: LIGHT DETECTING MODULE	VR.TRIM	: TRIMMER POTENTIOMETER

Note) Those parts marked with “#” are not included in the P.C.B. ass'y.

P.C.B. DSP

Schm Ref.	PART NO.	Description	Markets
	WDO44200	P. C. B.	DSP (YEM) UCKABEL
	WE741100	P. C. B.	DSP T
CB802	VQ961200	CN. BS. PIN	9P
CB803	VQ044500	CN. BS. PIN	11P
CB804	VF982200	CN. BS. PIN	14P
CB805	VQ961700	CN. BS. PIN	14P
C805	UR847220	C. EL	22uF 25V
C816	UR819100	C. EL	1000uF 6.3V
C822	UR829100	C. EL	1000uF 10V
C824	UR819100	C. EL	1000uF 6.3V
C827	UR818100	C. EL	100uF 6.3V
C828	UR819100	C. EL	1000uF 6.3V
C833	UR818470	C. EL	470uF 6.3V
C834	UR818100	C. EL	100uF 6.3V
C840	UR818470	C. EL	470uF 6.3V
C859	UR818100	C. EL	100uF 6.3V
C872	UR818100	C. EL	100uF 6.3V
C883	UR818100	C. EL	100uF 6.3V
C886	UR819100	C. EL	1000uF 6.3V
C891	UR819100	C. EL	1000uF 6.3V
C912	UR818100	C. EL	100uF 6.3V
C913	UR818100	C. EL	100uF 6.3V
C916	UR828100	C. EL	100uF 10V
C918	UR866220	C. EL	2.2uF 50V
C919	UR847100	C. EL	10uF 25V
C920	UR847100	C. EL	10uF 25V
D801	VT332900	DIODE	1SS355
D802	VT332900	DIODE	1SS355
D803	VT332900	DIODE	1SS355
D804	VT332900	DIODE	1SS355
D805	VT332900	DIODE	1SS355
D806	VT332900	DIODE	1SS355
D807	WB081800	DIODE	SB01-05Q
D808	WB081800	DIODE	SB01-05Q
D809	WB081800	DIODE	SB01-05Q
D810	WB081800	DIODE	SB01-05Q
IC801	X0238B00	IC	YSS938
IC802	XV077B00	IC	MSM514260E-60JS
IC803	X3807A00	IC	AK4628VQ
IC804	XZ003A00	IC	P0025EZ5MZP 2.5V
IC805	X6051A00	IC	UPC29M33T-E1-AZ
IC806	XZ012A00	IC	TC74HCT08AF (EL)
IC807	XY070A00	IC	MM74HCU04SJX INVER
PJ801	V4483900	JACK. PIN	1P YKC21-3895
R807	HV753220	R. CAR. FP	2.2Ω 1/4W
R892	HV753220	R. CAR. FP	2.2Ω 1/4W
R902	HV753100	R. CAR. FP	1Ω 1/4W
R903	HV753100	R. CAR. FP	1Ω 1/4W
R910	VU224000	R. MTL. FLM	0.22Ω 1W
R919	RE045100	R. ARRAY	100Ω x4
R920	RE045100	R. ARRAY	100Ω x4
R921	RE045100	R. ARRAY	100Ω x4
R922	RE045100	R. ARRAY	100Ω x4

* New Parts

P.C.B. DSP & P.C.B. FUNCTION

Schm Ref.	PART NO.	Description	Markets
U801	WB001400	CN. PHOT. SN	1P GP1FA553RZ
U802	WB001400	CN. PHOT. SN	1P GP1FA553RZ
XL801	V3625700	RSNR. CRYST	24.576MHz
	WE545000	P. C. B.	FUNCTION UCTKA
	WE545100	P. C. B.	FUNCTION R
	WE545200	P. C. B.	FUNCTION BGE
	WE857100	P. C. B.	FUNCTION (YEM) L
CB431	VK026300	CN. BS. PIN	4P
CB451	VQ963900	CN. BS. PIN	18P
CB452	VQ961500	CN. BS. PIN	12P
CB453	VM859500	CN. BS. PIN	11P
CB454	VQ961200	CN. BS. PIN	9P
CB551	VN394900	CN. BS. PIN	14P
CB611	VQ962100	CN. BS. PIN	18P
CB652	LB919090	CN. BS. PIN	9P
CB653	VK024700	CN. BS. PIN	3P
CB676	VQ963900	CN. BS. PIN	18P
CB677	VQ962100	CN. BS. PIN	18P
CB691	V9377900	CN. BS. PIN	4P SE VH SERIES RL
C431	UA654100	C. MYLAR	0.01uF 50V
C432	UA654100	C. MYLAR	0.01uF 50V
C433	UA654100	C. MYLAR	0.01uF 50V
C434	UA654100	C. MYLAR	0.01uF 50V
C457	UA652220	C. MYLAR	220pF 50V
C458	UA652220	C. MYLAR	220pF 50V
C459	UA652220	C. MYLAR	220pF 50V
C460	UA652220	C. MYLAR	220pF 50V
C461	FG651470	C. CE	47pF 50V
C462	FG651470	C. CE	47pF 50V
C463	UR837100	C. EL	10uF 16V
C464	UR837100	C. EL	10uF 16V
C465	UR837100	C. EL	10uF 16V
C466	UR837100	C. EL	10uF 16V
C467	UR847470	C. EL	47uF 25V
C468	UR847470	C. EL	47uF 25V
C469	UR838100	C. EL	100uF 16V
C470	UR838100	C. EL	100uF 16V
C473	UR837100	C. EL	10uF 16V
C474	UR837100	C. EL	10uF 16V
C475	UR837100	C. EL	10uF 16V
C476	UR837100	C. EL	10uF 16V
C477	UR837100	C. EL	10uF 16V
C478	UR837100	C. EL	10uF 16V
C479	UR837100	C. EL	10uF 16V
C480	UA653470	C. MYLAR	4700pF 50V
C481	VE326000	C. MYLAR. ML	0.1uF 50V
C482	VE326000	C. MYLAR. ML	0.1uF 50V
C483	UA653470	C. MYLAR	4700pF 50V
C484	VE326000	C. MYLAR. ML	0.1uF 50V
C485	VE326000	C. MYLAR. ML	0.1uF 50V

* New Parts

RX-V357/HTR-5830

P.C.B. FUNCTION

Schm Ref.	PART NO.	Description	Markets
C486	UR837100	C. EL 10uF 16V	
C487	UR837100	C. EL 10uF 16V	
C488	UR866220	C. EL 2. 2uF 50V	
C489	UR837100	C. EL 10uF 16V	
C490	UR837100	C. EL 10uF 16V	
C491	UR837100	C. EL 10uF 16V	
C492	UR837100	C. EL 10uF 16V	
C493	UR837100	C. EL 10uF 16V	
C494	UR837100	C. EL 10uF 16V	
C495	UR837100	C. EL 10uF 16V	
C496	UR837100	C. EL 10uF 16V	
C497	UR837100	C. EL 10uF 16V	
C498	UA654470	C. MYLAR 0. 047uF 50V	
C499	UA652100	C. MYLAR 100pF 50V	
C500	UR838100	C. EL 100uF 16V	
C501	UR838100	C. EL 100uF 16V	
C502	UA652100	C. MYLAR 100pF 50V	
C503	UA652100	C. MYLAR 100pF 50V	
C504	UA652100	C. MYLAR 100pF 50V	
C505	UA652100	C. MYLAR 100pF 50V	
C506	UA652100	C. MYLAR 100pF 50V	
C507	UA653390	C. MYLAR 3900pF 50V	
C508	UR837100	C. EL 10uF 16V	
C509	UR837100	C. EL 10uF 16V	
C510	UR837100	C. EL 10uF 16V	
C511	UA652100	C. MYLAR 100pF 50V	
C512	UA652100	C. MYLAR 100pF 50V	
C513	UR837100	C. EL 10uF 16V	
C514	UR837100	C. EL 10uF 16V	
C515	UR837100	C. EL 10uF 16V	
C516	UR837100	C. EL 10uF 16V	
C517	UR837100	C. EL 10uF 16V	
C518	UR837100	C. EL 10uF 16V	
C519	UA654270	C. MYLAR 0. 027uF 50V	
C520	UA654270	C. MYLAR 0. 027uF 50V	
C521	UR838100	C. EL 100uF 16V	
C522	UR838100	C. EL 100uF 16V	
C523	UA654270	C. MYLAR 0. 027uF 50V	
C524	UA654270	C. MYLAR 0. 027uF 50V	
C525	UR837100	C. EL 10uF 16V	
C526	UR837100	C. EL 10uF 16V	
C527	UA652820	C. MYLAR 820pF 50V	
C528	UA652820	C. MYLAR 820pF 50V	
C529	UA652820	C. MYLAR 820pF 50V	
C530	UA652820	C. MYLAR 820pF 50V	
C531	UA652820	C. MYLAR 820pF 50V	
C554	UR837100	C. EL 10uF 16V	
C562	UR818330	C. EL 330uF 6. 3V	
C612	UA652470	C. MYLAR 470pF 50V	
C614	UA652220	C. MYLAR 220pF 50V	
C615	UA652220	C. MYLAR 220pF 50V	
C616	UA652220	C. MYLAR 220pF 50V	
C617	UA652220	C. MYLAR 220pF 50V	

* New Parts

P.C.B. FUNCTION

Schm Ref.	PART NO.	Description	Markets
C618	UA652220	C. MYLAR 220pF 50V	
C619	UA652220	C. MYLAR 220pF 50V	
C620	UA652220	C. MYLAR 220pF 50V	
C621	UA652220	C. MYLAR 220pF 50V	
C622	FG651470	C. CE 47pF 50V	
C623	FG651470	C. CE 47pF 50V	
C624	UR837100	C. EL 10uF 16V	
C625	UR837100	C. EL 10uF 16V	
C626	UA654100	C. MYLAR 0. 01uF 50V	
C651	UR837470	C. EL 47uF 16V	
C652	UR837470	C. EL 47uF 16V	
C653	UR837470	C. EL 47uF 16V	
C654	UR837470	C. EL 47uF 16V	
C655	UR838100	C. EL 100uF 16V	
C656	UR838100	C. EL 100uF 16V	
C657	UR867100	C. EL 10uF 50V	
C658	UR867100	C. EL 10uF 50V	
C659	UR838100	C. EL 100uF 16V	
C660	UA654100	C. MYLAR 0. 01uF 50V	
C661	UR867100	C. EL 10uF 50V	
C662	UR73A100	C. EL 10000uF 16V	
C663	UR759220	C. EL 2200uF 35V	
C664	UR759100	C. EL 1000uF 35V	
C665	VE326000	C. MYLAR. ML 0. 1uF 50V	
C666	VE326000	C. MYLAR. ML 0. 1uF 50V	
C667	VE326000	C. MYLAR. ML 0. 1uF 50V	
C668	VE326000	C. MYLAR. ML 0. 1uF 50V	
C669	VE326000	C. MYLAR. ML 0. 1uF 50V	
D431	VU172500	D1ODE. ZENR UDZS9. 1B	
D432	VT332900	D1ODE 1SS355	
D433	VT332900	D1ODE 1SS355	
D451	VU994300	D1ODE. ZENR MA8075-H 7. 7V	
D452	VU994300	D1ODE. ZENR MA8075-H 7. 7V	
D551	VU172100	D1ODE. ZENR UDZS6. 2B 6. 2V	
D552	VU172100	D1ODE. ZENR UDZS6. 2B 6. 2V	
D651	VU172000	D1ODE. ZENR UDZS5. 6BTE-17 5. 6V	
D652	VU172000	D1ODE. ZENR UDZS5. 6BTE-17 5. 6V	
D653	WA653100	D1ODE. BRG KBP103G 1. 0A 200V	
D654	WA653100	D1ODE. BRG KBP103G 1. 0A 200V	
* IC451	X6299A00	IC BD3816K1-C	
IC452	X3505A00	IC NJM2068MD-TE2	
IC453	X3505A00	IC NJM2068MD-TE2	
IC454	X3505A00	IC NJM2068MD-TE2	
IC455	X3505A00	IC NJM2068MD-TE2	
IC456	X3505A00	IC NJM2068MD-TE2	
IC551	X2874A00	IC M66003-0101FP FLD	
IC651	X4153A00	IC KIA7812PI	
IC652	X4154A00	IC KIA7912PI	
IC653	X4928A00	IC KIA7805API 5V	
JK431	V9408200	JACK. PHONE MSJ-064-05B GR	
PJ451	V7190400	JACK. PIN 6P	
PJ452	V7046800	JACK. PIN 6P MSP-246V1-01N1	
PJ611	V7189700	JACK. PIN 1P	

* New Parts

P.C.B. FUNCTION

Schm Ref.	PART NO.	Description	Markets
PJ612	V7046700	JACK. PIN	4P MSP-244V1-01NI
PJ613	V7046800	JACK. PIN	6P MSP-246V1-01NI
PN451	WB213200	PIN	L=70 WB21320
PN551	WB213200	PIN	L=70 WB21320
PN651	WB213200	PIN	L=70 WB21320
PN696	WB213200	PIN	L=70 WB21320
PN697	WB213200	PIN	L=70 WB21320
Q451	iC181510	TR	2SC1815 Y
Q452	iA101510	TR	2SA1015 Y
Q453	VD303700	TR	2SC3326 A, B
Q454	VD303700	TR	2SC3326 A, B
Q455	VD303700	TR	2SC3326 A, B
Q456	VD303700	TR	2SC3326 A, B
Q551	VV556400	TR	2SC2412K Q, R, S
Q552	VV556400	TR	2SC2412K Q, R, S
Q553	VV556400	TR	2SC2412K Q, R, S
Q554	VV556400	TR	2SC2412K Q, R, S
Q555	VV556400	TR	2SC2412K Q, R, S
Q556	VV556400	TR	2SC2412K Q, R, S
Q611	VZ725900	TR	2SD1938F S, T
Q612	VZ725900	TR	2SD1938F S, T
Q651	VK407600	TR	2SC4208A Q, R, S
Q652	iA101510	TR	2SA1015 Y
R431	VP940800	R. MTL. OXD	470 Ω 1W
R432	VP940800	R. MTL. OXD	470 Ω 1W
R483	HV753220	R. CAR. FP	2.2 Ω 1/4W
R484	HV753220	R. CAR. FP	2.2 Ω 1/4W
R589	HV755100	R. CAR. FP	100 Ω 1/4W
R592	HV755100	R. CAR. FP	100 Ω 1/4W
R651	HV753470	R. CAR. FP	4.7 Ω 1/4W
R652	HV753470	R. CAR. FP	4.7 Ω 1/4W
R657	HV753100	R. CAR. FP	1 Ω 1/4W
R658	HV753100	R. CAR. FP	1 Ω 1/4W
R660	VP939500	R. MTL. FLM	1 Ω 1W
R663	HV753100	R. CAR. FP	1 Ω 1/4W
R664	HV753100	R. CAR. FP	1 Ω 1/4W
ST431	WA789700	SCR. TERM	
ST451	WA789600	SCR. TERM	M3
SW551	V9281300	SW. RT. ENC	EVEKD2F3024B
SW552	WD483100	SW. TACT	SKRGAAD010
SW553	WD483100	SW. TACT	SKRGAAD010
SW554	WD483100	SW. TACT	SKRGAAD010
SW555	WD483100	SW. TACT	SKRGAAD010
SW556	WD483100	SW. TACT	SKRGAAD010
SW557	WD483100	SW. TACT	SKRGAAD010
SW558	WD483100	SW. TACT	SKRGAAD010
SW559	WD483100	SW. TACT	SKRGAAD010
SW560	WD483100	SW. TACT	SKRGAAD010
SW561	WD483100	SW. TACT	SKRGAAD010
SW562	WD483100	SW. TACT	SKRGAAD010
SW563	WD483100	SW. TACT	SKRGAAD010
SW564	WD483100	SW. TACT	SKRGAAD010
SW565	WD483100	SW. TACT	SKRGAAD010

* New Parts

P.C.B. FUNCTION & P.C.B. MAIN

Schm Ref.	PART NO.	Description	Markets
SW566	WD483100	SW. TACT	SKRGAAD010
SW567	WD483100	SW. TACT	SKRGAAD010
SW568	WD483100	SW. TACT	SKRGAAD010
SW569	WD483100	SW. TACT	SKRGAAD010
SW570	WD483100	SW. TACT	SKRGAAD010
SW571	WD483100	SW. TACT	SKRGAAD010
SW572	WD483100	SW. TACT	SKRGAAD010
SW573	WD483100	SW. TACT	SKRGAAD010
SW671	WD483100	SW. TACT	SKRGAAD010
SW691	VZ075500	SW. SL IDE	SL14-22AM5F
U551	WC746300	L. DTCT	RPM7138-H9
V551	WC173100	FL. DSPLY	16-BT-122GNK
	WA790800	SHEET	
	WA790900	SPACER	4.6/10/32
*	WE544300	P. C. B.	MAIN UC
*	WE544400	P. C. B.	MAIN R
*	WE544500	P. C. B.	MAIN T
*	WE544600	P. C. B.	MAIN K
*	WE544700	P. C. B.	MAIN A
*	WE544800	P. C. B.	MAIN BGE
*	WE856900	P. C. B.	MAIN (YEM) L
CB101	V0963000	CN. BS. PIN	9P
CB103	VK024700	CN. BS. PIN	3P
CB104	LB932040	CN. BS. PIN	4P
CB242	VM923600	CN. BS. PIN	13P
CB244	V0963300	CN. BS. PIN	12P
CB246	VF728200	CN. BS. PIN	10P
CB247	V0963000	CN. BS. PIN	9P
CB248	V0044400	CN. BS. PIN	9P
CB249	V0963500	CN. BS. PIN	14P
CB372	WC050700	CL. IP. FUSE	EYF52BCY
CB373	WC050700	CL. IP. FUSE	EYF52BCY
CB374	VG879900	CN. BS. PIN	2P
CB375	VG879900	CN. BS. PIN	2P
CB381	LB933050	CN. BS. PIN	5P SE VH UC
CB391	VK026400	CN. BS. PIN	5P
CB701	VB858300	CN. BS. PIN	4P
C101	UA654100	C. MYLAR	0.01uF 50V
C102	UR877100	C. EL	10uF 63V
C103	UR877100	C. EL	10uF 63V
C104	UR877100	C. EL	10uF 63V
C105	UR877100	C. EL	10uF 63V
C106	UR877100	C. EL	10uF 63V
C107	UA652220	C. MYLAR	220pF 50V
C108	UA652220	C. MYLAR	220pF 50V
C109	UA652220	C. MYLAR	220pF 50V
C110	UA652220	C. MYLAR	220pF 50V
C111	UA652220	C. MYLAR	220pF 50V
C112	UR877100	C. EL	10uF 63V
C113	UR877100	C. EL	10uF 63V

* New Parts

RX-V357/HTR-5830

P.C.B. MAIN

Schm Ref.	PART NO.	Description	Markets
C114	UR867330	C. EL 33uF 50V	
C115	UA652100	C. MYLAR 100pF 50V	
C116	UR877100	C. EL 10uF 63V	
C117	UR877220	C. EL 22uF 63V	
C118	UR877100	C. EL 10uF 63V	
C119	UR877220	C. EL 22uF 63V	
C120	FG651100	C. CE 10pF 50V	
C122	UR877100	C. EL 10uF 63V	
C123	UR877100	C. EL 10uF 63V	
C124	UR877100	C. EL 10uF 63V	
C125	UA652100	C. MYLAR 100pF 50V	
C126	UA652100	C. MYLAR 100pF 50V	
C127	UR867330	C. EL 33uF 50V	
C128	UR867330	C. EL 33uF 50V	
C129	UR867330	C. EL 33uF 50V	
C130	UR867330	C. EL 33uF 50V	
C131	UA652100	C. MYLAR 100pF 50V	
C132	UR877220	C. EL 22uF 63V	
C133	UA652100	C. MYLAR 100pF 50V	
C135	FG651100	C. CE 10pF 50V	
C136	FG651100	C. CE 10pF 50V	
C137	FG651100	C. CE 10pF 50V	
C138	FG651100	C. CE 10pF 50V	
C139	VE326000	C. MYLAR. ML 0. 1uF 50V	
C140	VE326000	C. MYLAR. ML 0. 1uF 50V	
C141	VE326000	C. MYLAR. ML 0. 1uF 50V	
C142	VE326000	C. MYLAR. ML 0. 1uF 50V	
C143	VE326000	C. MYLAR. ML 0. 1uF 50V	
C144	UR876470	C. EL 4. 7uF 63V	
C145	UR828220	C. EL 220uF 10V	
C146	UR858100	C. EL 100uF 35V	
C147	UR866470	C. EL 4. 7uF 50V	
C148	UA654100	C. MYLAR 0. 01uF 50V	RTKABGEL
C149	UR868100	C. EL 100uF 50V	RTKABGEL
C150	UA654100	C. MYLAR 0. 01uF 50V	
* C152	WE514200	C. EL 6800uF 63V	UCRTKAL
* C152	WC998700	C. EL 6800uF 63V	BGE
* C153	WE514200	C. EL 6800uF 63V	UCRTKAL
C153	WC998700	C. EL 6800uF 63V	BGE
C154	UA654100	C. MYLAR 0. 01uF 50V	KABGEL
C155	UA654100	C. MYLAR 0. 01uF 50V	KABGEL
C156	UA654100	C. MYLAR 0. 01uF 50V	KABGEL
C157	UA654100	C. MYLAR 0. 01uF 50V	KABGEL
C158	UA654100	C. MYLAR 0. 01uF 50V	
C159	VR324900	C. MYLAR 0. 1uF 100V	
C160	VR324900	C. MYLAR 0. 1uF 100V	
C161	UR866100	C. EL 1uF 50V	
C162	UA654100	C. MYLAR 0. 01uF 50V	RTKABGEL
C163	UA654100	C. MYLAR 0. 01uF 50V	RTKABGEL
C164	UA652100	C. MYLAR 100pF 50V	KABGE
C165	UA652100	C. MYLAR 100pF 50V	KABGE
C167	UA652470	C. MYLAR 470pF 50V	KABGE

* New Parts

P.C.B. MAIN

Schm Ref.	PART NO.	Description	Markets
C168	UA652470	C. MYLAR 470pF 50V	KABGE
C243	UR819100	C. EL 1000uF 6. 3V	
C244	UR819100	C. EL 1000uF 6. 3V	
C248	UR866100	C. EL 1uF 50V	
C253	UR857470	C. EL 47uF 35V	
C254	UR877100	C. EL 10uF 63V	
C256	UR847470	C. EL 47uF 25V	
C258	WB165500	C. EL 0. 33F 5. 5V	
C259	UR818220	C. EL 220uF 6. 3V	
C260	UR847470	C. EL 47uF 25V	
C261	UR837330	C. EL 33uF 16V	
C263	UR877100	C. EL 10uF 63V	
C264	UR818470	C. EL 470uF 6. 3V	
C274	UR847470	C. EL 47uF 25V	BGE
C275	UR847470	C. EL 47uF 25V	BGE
C277	VA761100	C. CE 27pF 50V	BGE
C279	VA761100	C. CE 27pF 50V	BGE
C280	UR847470	C. EL 47uF 25V	BGE
C283	UR866220	C. EL 2. 2uF 50V	
C284	UR866220	C. EL 2. 2uF 50V	
C285	UR866220	C. EL 2. 2uF 50V	
C286	UR866220	C. EL 2. 2uF 50V	
C371	UR858470	C. EL 470uF 35V	
C372	UA654100	C. MYLAR 0. 01uF 50V	
C373	UR897100	C. EL 10uF 100V	RL
C374	UA654100	C. MYLAR 0. 01uF 50V	UCTKABGE
C375	UA654100	C. MYLAR 0. 01uF 50V	RL
C376	UA654100	C. MYLAR 0. 01uF 50V	RL
⚠ C377	WB121400	C. CE. SAFTY 0. 01uF 295V	
C381	UR877100	C. EL 10uF 63V	UC
C382	UR877100	C. EL 10uF 63V	UC
C393	UR877100	C. EL 10uF 63V	
C394	UR877100	C. EL 10uF 63V	
C395	UR877100	C. EL 10uF 63V	
C396	UR877100	C. EL 10uF 63V	
C397	UR829100	C. EL 1000uF 10V	
C398	UR829100	C. EL 1000uF 10V	
C401	UR838100	C. EL 100uF 16V	
C411	UA654100	C. MYLAR 0. 01uF 50V	RTKABGEL
C412	UA654100	C. MYLAR 0. 01uF 50V	RTKABGEL
C415	UA654100	C. MYLAR 0. 01uF 50V	KABGEL
C416	UA654100	C. MYLAR 0. 01uF 50V	KABGEL
C417	UA652100	C. MYLAR 100pF 50V	KABGE
C418	UA652470	C. MYLAR 470pF 50V	KABGEL
C707	UR877100	C. EL 10uF 63V	
C708	UR877100	C. EL 10uF 63V	
C709	UR837100	C. EL 10uF 16V	
C710	UR837100	C. EL 10uF 16V	
C711	UR837100	C. EL 10uF 16V	
D101	VT332900	D1ODE 1SS355	
D102	VT332900	D1ODE 1SS355	
⚠ D103	VD631600	D1ODE 1SS133, 176	
D107	WC398800	D1ODE KDS160-RTK	

* New Parts

RX-V357/HTR-5830

P.C.B. MAIN

P.C.B. MAIN

Schm Ref.	PART NO.	Description	Markets
D108	VN008700	DIODE 1SS270A	
D109	VN008700	DIODE 1SS270A	
D110	WC398800	DIODE KDS160-RTK	
D111	VN008700	DIODE 1SS270A	
D112	VN008700	DIODE 1SS270A	
D113	VN008700	DIODE 1SS270A	
D114	VN008700	DIODE 1SS270A	
D115	VN008700	DIODE 1SS270A	
D116	VU171900	DIODE.ZENR UZD5.1B 5.1V	
D117	VN008700	DIODE 1SS270A	
D118	VD631600	DIODE 1SS133,176	
D119	VD631600	DIODE 1SS133,176	
⚠ D120	VG443200	DIODE.ZENR MTZJ30A 30V	
⚠ D121	VD631600	DIODE 1SS133,176	
⚠ D122	WA653200	DIODE.BRG TS6P03G 6.0A 200V	
D123	VD631600	DIODE 1SS133,176	
D241	VT332900	DIODE 1SS355	
D242	VT332900	DIODE 1SS355	
D243	VU172200	DIODE.ZENR UZD6.8B 6.8V	
D244	VT332900	DIODE 1SS355	
D245	VU172100	DIODE.ZENR UZDS6.2B 6.2V	
D246	VT332900	DIODE 1SS355	
D247	VT332900	DIODE 1SS355	
D249	VT332900	DIODE 1SS355	
D250	VU995500	DIODE.ZENR MA8100-H 10.3V	
D251	VT332900	DIODE 1SS355	
D252	VU171900	DIODE.ZENR UZD5.1B 5.1V	
D253	VT332900	DIODE 1SS355	UC
D254	VU171900	DIODE.ZENR UZD5.1B 5.1V	
D255	VU171900	DIODE.ZENR UZD5.1B 5.1V	
D256	VU171900	DIODE.ZENR UZD5.1B 5.1V	
D257	VU171900	DIODE.ZENR UZD5.1B 5.1V	
D258	VU171900	DIODE.ZENR UZD5.1B 5.1V	
D259	VU171900	DIODE.ZENR UZD5.1B 5.1V	
D371	VD631600	DIODE 1SS133,176	
D372	VG437000	DIODE.ZENR MTZJ4.7A 4.7V	RL
⚠ D373	VS997800	DIODE 1T2	
⚠ D374	VS997800	DIODE 1T2	
⚠ D375	VS997800	DIODE 1T2	RL
⚠ D376	VS997800	DIODE 1T2	
⚠ D377	VS997800	DIODE 1T2	
D381	VT532500	DIODE 1SR154-400	UC
D382	VT532500	DIODE 1SR154-400	UC
D411	VD631600	DIODE 1SS133,176	
⚠ F371	WB221200	FUSE T6A 125V	UCRL
⚠ F371	VV071700	FUSE TSD 3.15A 250V SEM	TKABGE
⚠ IC101	X5064A00	IC STK404-130Y 130W	
⚠ IC102	X5063A00	IC STK403-130Y 130W	
⚠ IC103	X5063A00	IC STK403-130Y 130W	
IC241	X0082A00	IC LC72722PM	BGE
* IC242	X6305A00	IC.CPU M30626FHPPF(written)	
IC391	XH436A00	IC LA7956	
IC701	XY879A00	IC TC74HC4053AF(EL)	

* New Parts

Schm Ref.	PART NO.	Description	Markets
IC702	X2904A00	IC NJM2581M VIDEO AMP	
PJ391	V7190000	JACK.PIN 2P	
PJ392	V7190000	JACK.PIN 2P	
PJ393	V7190000	JACK.PIN 2P	
PJ701	V8143900	JACK PIN 9P SHIELD YKC21	
PN391	WB213200	PIN L=70 WB21320	
PN412	WB213200	PIN L=70 WB21320	
PN701	WB213200	PIN L=70 WB21320	
⚠ Q101	VD303700	TR 2SC3326 A,B	
⚠ Q102	VD303700	TR 2SC3326 A,B	
⚠ Q103	VD303700	TR 2SC3326 A,B	
⚠ Q104	VD303700	TR 2SC3326 A,B	
⚠ Q105	VD303700	TR 2SC3326 A,B	
Q106	V3966800	TR 2SA949 0,Y	
Q107	WC398400	TR 2SC2N5551C-AT	
⚠ Q108	VC407900	TR 2SD1913 R,S	
Q112	WC398400	TR 2SC2N5551C-AT	
Q113	WC398400	TR 2SC2N5551C-AT	
Q114	WC398400	TR 2SC2N5551C-AT	
Q115	WC398400	TR 2SC2N5551C-AT	
Q116	WC398400	TR 2SC2N5551C-AT	
Q117	WC397700	TR 2SA2N5401C-AT	
Q118	WC434900	TR.DGT KRA104S-RTK	
Q119	WC434900	TR.DGT KRA104S-RTK	
Q120	WC434900	TR.DGT KRA104S-RTK	
Q121	iA101510	TR 2SA1015 Y	
Q122	WC434900	TR.DGT KRA104S-RTK	
Q123	iC181510	TR 2SC1815 Y	
Q124	WC434900	TR.DGT KRA104S-RTK	
Q243	VP872700	TR 2SC4488 S,T	
Q244	VP872600	TR 2SA1708 S,T	
Q245	WC435000	TR.DGT KRC102S-RTK	
Q246	WC435100	TR.DGT KRC104S-RTK	
Q247	iC181510	TR 2SC1815 Y	
Q248	WC435100	TR.DGT KRC104S-RTK	
Q249	VP872700	TR 2SC4488 S,T	RL
Q250	WC435100	TR.DGT KRC104S-RTK	
Q251	iC174020	TR 2SC1740S QRS	BGE
Q252	WC435100	TR.DGT KRC104S-RTK	
Q253	VV556400	TR 2SC2412K O,R,S	UC
Q254	VV556500	TR 2SA1037K O,R,S	
Q255	VV556500	TR 2SA1037K O,R,S	
Q256	VV556500	TR 2SA1037K O,R,S	
Q257	VV556500	TR 2SA1037K O,R,S	
Q258	VV556500	TR 2SA1037K O,R,S	
Q259	VV556400	TR 2SC2412K O,R,S	
Q260	VV556500	TR 2SA1037K O,R,S	
Q261	VV556400	TR 2SC2412K O,R,S	
Q262	WC398600	TR.DGT KRA104M-AT	
Q371	VE198800	TR 2SC2705 0,Y	
Q372	iA101510	TR 2SA1015 Y	RL
Q373	VP872600	TR 2SA1708 S,T	RL
Q374	iA101510	TR 2SA1015 Y	RL

* New Parts

RX-V357/HTR-5830

P.C.B. MAIN

Schm Ref.	PART NO.	Description	Markets	
Q375	WC529200	TR. DGT	KRC102M-AT	RL
Q391	iC181510	TR	2SC1815 Y	
Q392	iC181510	TR	2SC1815 Y	
Q393	iC174020	TR	2SC1740S QRS	
Q701	VD303700	TR	2SC3326 A, B	
R121	HV753220	R. CAR. FP	2. 2Ω 1/4W	
R122	HV753220	R. CAR. FP	2. 2Ω 1/4W	
R125	HV753220	R. CAR. FP	2. 2Ω 1/4W	
R126	HV753220	R. CAR. FP	2. 2Ω 1/4W	
⚠ R129	HV754470	R. CAR. FP	47 Ω 1/4W	
R130	HV753220	R. CAR. FP	2. 2Ω 1/4W	
R132	HV753220	R. CAR. FP	2. 2Ω 1/4W	
⚠ R133	HV754100	R. CAR. FP	10 Ω 1/4W	
⚠ R143	HV756470	R. CAR. FP	4. 7KΩ 1/4W	
⚠ R144	HV754100	R. CAR. FP	10 Ω 1/4W	
R148	WB279900	R. WW	RGC55C 0. 22+0. 22	
R156	WB279900	R. WW	RGC55C 0. 22+0. 22	
R157	WB279900	R. WW	RGC55C 0. 22+0. 22	
R158	WB279900	R. WW	RGC55C 0. 22+0. 22	
R159	WB279900	R. WW	RGC55C 0. 22+0. 22	
R166	HV753470	R. CAR. FP	4. 7 Ω 1/4W	
⚠ R171	VP939700	R. MTL. FLM	4. 7 Ω 1W	
R178	HV753470	R. CAR. FP	4. 7 Ω 1/4W	
R180	HV753470	R. CAR. FP	4. 7 Ω 1/4W	
R182	HV753470	R. CAR. FP	4. 7 Ω 1/4W	
R184	HV753470	R. CAR. FP	4. 7 Ω 1/4W	
⚠ R190	VP939700	R. MTL. FLM	4. 7 Ω 1W	
⚠ R191	VP939700	R. MTL. FLM	4. 7 Ω 1W	
⚠ R192	VP939700	R. MTL. FLM	4. 7 Ω 1W	
⚠ R193	VP939700	R. MTL. FLM	4. 7 Ω 1W	
R198	HV756470	R. CAR. FP	4. 7KΩ 1/4W	
R201	HV755330	R. CAR. FP	330 Ω 1/4W	RTKABGEL
R204	HV753220	R. CAR. FP	2. 2Ω 1/4W	RTKABGEL
R206	HV753220	R. CAR. FP	2. 2Ω 1/4W	
R208	HV753220	R. CAR. FP	2. 2Ω 1/4W	
R216	HV753220	R. CAR. FP	2. 2Ω 1/4W	RTKABGEL
R217	HV753220	R. CAR. FP	2. 2Ω 1/4W	RTKABGEL
R219	HV754100	R. CAR. FP	10 Ω 1/4W	KABGEL
R220	HV754100	R. CAR. FP	10 Ω 1/4W	KABGEL
R378	VC757900	R. MTL. OXD	47 Ω 2W	RL
R380	V6730000	R. CAR.	2. 2MΩ 1/2W	UC
R381	HV753100	R. CAR. FP	1 Ω 1/4W	UC
R382	HV753100	R. CAR. FP	1 Ω 1/4W	UC
R399	HV755270	R. CAR. FP	270 Ω 1/4W	
R405	HV753220	R. CAR. FP	2. 2Ω 1/4W	
R411	HV753220	R. CAR. FP	2. 2Ω 1/4W	RTKABGEL
R414	HV753220	R. CAR. FP	2. 2Ω 1/4W	RTKABGEL
R415	HV754100	R. CAR. FP	10 Ω 1/4W	KABGEL
RY101	V5966300	RELAY	DS24D2-OS (M)	
RY102	V5966300	RELAY	DS24D2-OS (M)	
RY104	V5178900	RELAY	DC DQ24D1-OS (M)	
RY105	V5966300	RELAY	DS24D2-OS (M)	
⚠ RY371	V2712300	RELAY	DC SDT-S-112LMR	

* New Parts

P.C.B. MAIN

Schm Ref.	PART NO.	Description	Markets	
RY411	V5966300	RELAY	DS24D2-OS (M)	
ST241	WA789600	SCR. TERM	M3	
ST371	WA789600	SCR. TERM	M3	
SW381	VZ075500	SW. SLIDE	SL14-22AM5F	UC
⚠ T371	XW606A00	TRANS. PWR		UC
⚠ T371	XW974A00	TRANS. PWR		RL
⚠ T371	XW608A00	TRANS. PWR		TKABGE
TE101	VY696300	TERM. SP	4P	UCRTA
TE101	VY696400	TERM. SP	4P	KBGEL
TE102	WB054000	TERM. SP	YKD21-5002N	
TE411	WB054100	TERM. SP	YKD21-5004N	
XL241	V3930900	RSNR. CRYST	4. 332MHz	BGE
XL242	WB213000	RSNR. CE	16. 0MHz	
	EP600140	SCR. BND. HD	3x10 MFZN2BL	

* New Parts

CHIP PARTS

Schm Ref.	PART NO.	Description	Markets	
	US061100	C. CE. M. CHP	10pF 50V	
	US061180	C. CE. CHP	18pF 50V	
	US061220	C. CE. M. CHP	22pF 50V	
	US061330	C. CE. M. CHP	33pF 50V	
	US061470	C. CE. M. CHP	47pF 50V	
	US062100	C. CE. M. CHP	100pF 50V	
	US062220	C. CE. CHP	220pF 50V	
	US062330	C. CE. M. CHP	330pF 50V	
	US062470	C. CE. M. CHP	470pF 50V	
	US062560	C. CE. CHP	560pF 50V	
	US063100	C. CE. M. CHP	1000pF 50V	
	US063470	C. CE. CHP	4700pF 50V	
	US064100	C. CE. M. CHP	0. 01uF 50V	
	US135100	C. CE. CHP	0. 1uF 16V	
	US135220	C. CE. CHP	0. 22uF 16V	
	RD350000	R. CHP	0 Ω 1/16W	
	RD353220	R. CHP	2. 2 Ω 1/16W	
	RD354150	R. CHP	15 Ω 1/16W	
	RD354470	R. CHP	47 Ω 1/16W	
	RD354750	R. CHP	75 Ω 1/16W	
	RD354820	R. CHP	82 Ω 1/16W	
	RD355100	R. CHP	100 Ω 1/16W	
	RD355220	R. CHP	220 Ω 1/16W	
	RD355470	R. CHP	470 Ω 1/16W	
	RD355560	R. CHP	560 Ω 1/16W	
	RD355680	R. CHP	680 Ω 1/16W	
	RD355820	R. CHP	820 Ω 1/16W	
	RD356100	R. CHP	1K Ω 1/16W	
	RD356150	R. CHP	1. 5K Ω 1/16W	
	RD356180	R. CHP	1. 8K Ω 1/16W	
	RD356200	R. CHP	2K Ω 1/16W	
	RD356220	R. CHP	2. 2K Ω 1/16W	
	RD356240	R. CHP	2. 4K Ω 1/16W	
	RD356330	R. CHP	3. 3K Ω 1/16W	
	RD356470	R. CHP	4. 7K Ω 1/16W	
	RD356510	R. CHP	5. 1K Ω 1/16W	
	RD356560	R. CHP	5. 6K Ω 1/16W	
	RD356680	R. CHP	6. 8K Ω 1/16W	
	RD356820	R. CHP	8. 2K Ω 1/16W	
	RD357100	R. CHP	10K Ω 1/16W	
	RD357150	R. CHP	15K Ω 1/16W	
	RD357180	R. CHP	18K Ω 1/16W	
	RD357220	R. CHP	22K Ω 1/16W	
	RD357330	R. CHP	33K Ω 1/16W	
	RD357470	R. CHP	47K Ω 1/16W	
	RD357680	R. CHP	68K Ω 1/16W	
	RD358100	R. CHP	100K Ω 1/16W	
	RD358220	R. CHP	220K Ω 1/16W	
	RD358470	R. CHP	470K Ω 1/16W	
	RD359100	R. CHP	1M Ω 1/16W	

* New Parts

MECHANICAL PARTS

Schm Ref.	PART NO.	Description	Remarks	Markets
* 1-1	WE545000	P. C. B. ASS'Y	FUNCTION	UCTKA
* 1-1	WE545100	P. C. B. ASS'Y	FUNCTION	R
* 1-1	WE545200	P. C. B. ASS'Y	FUNCTION	BGE
* 1-1	WE857100	P. C. B. ASS'Y	FUNCTION (YEM)	L
* 1-2	MF114180	FLEXIBLE FLAT CABLE	14P 180mm P=1.25	
* 1-4	WE066700	FRONT PANEL ASS'Y	V357GD	
* 1-4	WE233600	FRONT PANEL ASS'Y	V357BL	
* 1-4	WE066800	FRONT PANEL ASS'Y	V357SI	
* 1-4	WE067200	FRONT PANEL ASS'Y	5830GD	
* 1-4	WE067100	FRONT PANEL ASS'Y	5830BL	
* 1-4	WE067300	FRONT PANEL ASS'Y	5830SI	UCRTKA
* 1-4	WE762000	FRONT PANEL ASS'Y	5830SI	BGE
* 1-5	WC411600	BUTTONCASE 350	V357GD, 5830GD	
* 1-5	WC411500	BUTTONCASE 350	V357BL	
* 1-5	WC411800	BUTTONCASE 350	5730BL	
* 1-5	WC411700	BUTTONCASE 350	V357SI, 5830SI	
* 1-6	WC411900	BUTTON/RDS 350		BGE
* 1-13	WC910400	SHEET, WINDOW	V357, 5830	UCRKAL
* 1-13	WC412800	SHEET, WINDOW	V357, 5830	T
* 1-13	WE813800	SHEET, WINDOW	V357	BGE
* 1-13	WE814900	SHEET, WINDOW	5830	GE
* 1-25	WE774800	BIND HEAD P-TIGHT SCREW	3x8 MFZN2W3	
* 2-1	WD044200	P. C. B. ASS'Y	DSP (YEM)	UCRKABGEL
* 2-1	WE741100	P. C. B. ASS'Y	DSP	T
* 2-7	MF111070	FLEXIBLE FLAT CABLE	11P 70mm P=1.25	
* 2-20	WC656000	SUPPORT/TR 5P		
* 2-103	WE774600	SCREW IC	3x18 MFZN2W3	
* 2-104	VT669300	PW HEAD B-TIGHT SCREW	3x8-8 MFC2	
* 5	WE544300	P. C. B. ASS'Y	MAIN	UC
* 5	WE544400	P. C. B. ASS'Y	MAIN	R
* 5	WE544500	P. C. B. ASS'Y	MAIN	T
* 5	WE544600	P. C. B. ASS'Y	MAIN	K
* 5	WE544700	P. C. B. ASS'Y	MAIN	A
* 5	WE544800	P. C. B. ASS'Y	MAIN	BGE
* 5	WE856900	P. C. B. ASS'Y	MAIN (YEM)	L
* 12	WB424000	AM/FM TUNER	ENG06709Q	UCRTL
* 12	WB424100	AM/FM TUNER	ENG07711Q	KABGE
* 15	X6311A00	POWER TRANSFORMER		UC
* 15	X5278B00	POWER TRANSFORMER		RL
* 15	X5279B00	POWER TRANSFORMER		TK
* 15	X5280B00	POWER TRANSFORMER		A
* 15	X5275B00	POWER TRANSFORMER		BGE
* 16	WB120500	POWER CABLE	2m	UC
* 16	WC992700	POWER CABLE	2m	R
* 16	WB120600	POWER CABLE	2m	T
* 16	WC753000	POWER CABLE	2m	K
* 16	WC743700	POWER CABLE	2m	A
* 16	WB212200	POWER CABLE	2m	B
* 16	WB212300	POWER CABLE	2m	GE
* 16	VN363600	POWER CABLE	2m (YEM)	L
* 17	V2438700	CORD STOPPER	10P1	
* 23	MF113140	FLEXIBLE FLAT CABLE	13P 140mm P=1.25	

* New Parts

Schm Ref.	PART NO.	Description	Remarks	Markets
* 101	WE065200	TOP COVER	GD	T
* 101	WE538700	TOP COVER	GD (YEM)	L
* 101	WE065000	TOP COVER	BL	
* 101	WE538900	TOP COVER	SI (YEM)	UCRKABGEL
* 101	WE065100	TOP COVER	SI	T
* 103	WE065600	REAR PANEL	V357	UC
* 103	WE065700	REAR PANEL	V357	R
* 103	WE065800	REAR PANEL	V357	TK
* 103	WE233500	REAR PANEL	V357	A
* 103	WE066000	REAR PANEL	V357	BGE
* 103	WE065900	REAR PANEL	V357 (YEM)	L
* 103	WE066100	REAR PANEL	5830	UC
* 103	WE066200	REAR PANEL	5830	R
* 103	WE066300	REAR PANEL	5830	TK
* 103	WE066400	REAR PANEL	5830	A
* 103	WE066500	REAR PANEL	5830	BGE
* 109	WA796100	SUPPORT/PCB		
* 120	WA790600	LEG (GD)	D60/H21	GD
* 120	V0042500	LEG (GD)	D60/H21	GD (YEM)
* 120	VS025000	LEG (HS)	D60/H21	V357BL, SI
* 120	WA790700	LEG (BL)	D60/H21	5830BL
* 121	WE064300	KNOB D48	VOLUME	GD
* 121	WE064200	KNOB D48	VOLUME	BL
* 121	WE064400	KNOB D48	VOLUME	SI
* 150	VU590000	BINDING TIE	CBTD001B	
* 151	WB870100	DAMPER		
* 152	WC879000	DAMPER		
* 160	WE774100	BIND HEAD BONDING B-T. SCREW	3x8 MFZN2B3	
* 163	WE774300	BIND HEAD B-TIGHT SCREW	3x8 MFZN2W3	
* 164	WE774000	BIND HEAD SCREW	3x6 MFZN2W3	UCR
* 167	VT669300	PW HEAD B-TIGHT SCREW	3x8-8 MFC2	
* 168	WE774600	SCREW IC	3x18 MFZN2W3	
* 170	WE774700	BIND HEAD S-TIGHT SCREW	4x10 MFZN2W3	
* 171	VD069600	PW HEAD S-TIGHT SCREW	4x8-10 MFN133	GD, SI
* 171	VH313200	PW HEAD S-TIGHT SCREW	4x8-10 MFN13BL	BL
* 172	WE200400	DISH HEAD B-TIGHT SCREW	3x6 MFN133	GD, SI
* 172	WE200500	DISH HEAD B-TIGHT SCREW	3x6 MFN13BL	BL
* 200	WA220300	ACCESSORIES	RAV300	RRC4001-1001LC
* 200-1	AAX46580	BATTERY COVER		103RRC-244-01G
* 201	WA617700	REMOTE CONTROL	RAV16	RC1112921/00
* 201-1	AAX49660	BATTERY COVER		3139 224 22451
* 202	V6267000	INDOOR FM ANTENNA	1.4m 1pc	(YEM)
* 202	WB212500	INDOOR FM ANTENNA	1.4m 1pc	
* 202	WB212400	INDOOR FM ANTENNA	1.4m 1pc	
* 203	VR248500	AM LOOP ANTENNA	1.0m 1pc	(YEM)
* 203	WB212600	AM LOOP ANTENNA	1.0m 1pc	UCRKABGEL
		BATTERY, MANGANESE DRY	R6CP 2pcs	T

* New Parts

1 ■ REMOTE CONTROL RAV16 (B, G, E models)

The schematic diagram is not available.

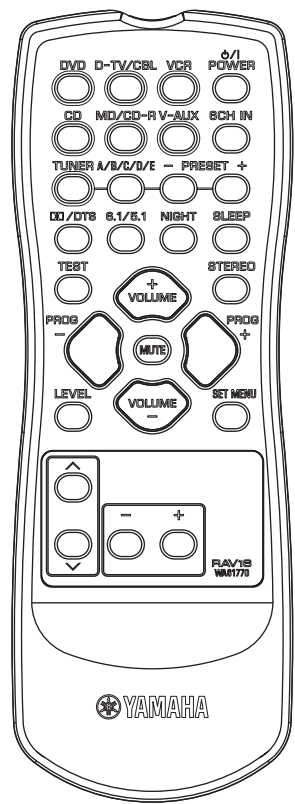

CUSTOM CODE: 7A

Key No.	Key Name	Data Code	Key No.	Key Name	Data Code
1	DVD	C1	18	VOLUME +	1A
2	D-TV/CBL	54	19	STEREO	56
3	VCR	0F	20	PROG -	59
4	POWER	1F	21	MUTE	1C
5	CD	15	22	PROG +	58
6	MD/CD-R	C9	23	LEVEL	86
7	V-AUX	55	24	VOLUME -	1B
8	6CH INPUT	87	25	SET MENU	9C
9	TUNER	16	26	^	98
10	A/B/C/D/E	12	27	_____	_____
11	PRESET -	11	28	_____	_____
12	PRESET +	10	29	_____	_____
13	□□ / DTS	90	30	∨	99
14	6.1 / 5.1	97	31	-	53
15	NIGHT	95	32	+	52
16	SLEEP	57	33	_____	_____
17	TEST	85			

Parts List for Carbon Resistors

Value	1/4W Type Part No.	1/6W Type Part No.	Value	1/4W Type Part No.	1/6W Type Part No.
1.0 Ω	HJ35 3100	HF85 3100	10 kΩ	HF45 7100	HF45 7100
1.8 Ω	HJ35 3180	*	11 kΩ	HF45 7110	HF45 7110
2.2 Ω	HJ35 3220	HF85 3220	12 kΩ	HJ35 7120	HF85 7120
3.3 Ω	HJ35 3330	HF85 3330	13 kΩ	HF45 7130	HF45 7130
4.7 Ω	HJ35 3470	HF85 3470	15 kΩ	HF45 7150	HF45 7150
5.6 Ω	HJ35 3560	HF85 3560	18 kΩ	HF45 7180	HF45 7180
10 Ω	HF45 4100	HF45 4100	22 kΩ	HF45 7220	HF45 7220
15 Ω	HJ35 4150	HF85 4150	24 kΩ	HF45 7240	HF45 7240
22 Ω	HF45 4220	HF45 4220	27 kΩ	HJ35 7270	HF85 7270
27 Ω	HJ35 4270	HF85 4270	30 kΩ	HF45 7300	HF45 7300
33 Ω	HF45 4330	HF45 4330	33 kΩ	HF45 7330	HF45 7330
39 Ω	HJ35 4470	HF85 4390	36 kΩ	HF45 7360	HF45 7360
47 Ω	HF45 4470	HF45 4470	39 kΩ	HF45 7390	HF45 7390
56 Ω	HF45 4560	HF45 4560	47 kΩ	HF45 7470	HF45 7470
68 Ω	HF45 4680	HF45 4680	51 kΩ	HF45 7510	HF45 7510
75 Ω	HF45 4750	HF45 4750	56 kΩ	HF45 7560	HF45 7560
82 Ω	HF45 4820	HF45 4820	62 kΩ	HF45 7620	HF45 7620
91 Ω	HF45 4910	HF45 4910	68 kΩ	HF45 7680	HF45 7680
100 Ω	HF45 5100	HF45 5100	82 kΩ	HF45 7820	HF45 7820
110 Ω	HJ35 5110	HF85 5110	91 kΩ	HF45 7910	HF45 7910
120 Ω	HF45 5120	HF45 5120	100 kΩ	HF45 8100	HF45 8100
150 Ω	HF45 5150	HF45 5150	110 kΩ	HF45 8110	HF45 8110
160 Ω	HJ35 5160	*	120 kΩ	HF45 8120	HF45 8120
180 Ω	HF45 5180	HF45 5180	150 kΩ	HF45 8150	HF45 8150
200 Ω	HF45 5200	HF45 5200	180 kΩ	HF45 8180	HF45 8180
220 Ω	HF45 5220	HF45 5220	220 kΩ	HJ35 8220	HF85 8220
270 Ω	HF45 5270	HF45 5270	270 kΩ	HF45 8270	HF45 8270
330 Ω	HF45 5330	HF45 5330	300 kΩ	HF45 8300	HF45 8300
390 Ω	HF45 5390	HF45 5390	330 kΩ	HF45 8330	HF45 8330
430 Ω	HF45 5430	HF45 5430	390 kΩ	HJ35 8390	HF85 8390
470 Ω	HF45 5470	HF45 5470	470 kΩ	HF45 8470	HF45 8470
510 Ω	HF45 5510	HF45 5510	560 kΩ	HJ35 8560	HF85 8560
560 Ω	HF45 5560	HF45 5560	680 kΩ	HJ35 8680	HF85 8680
680 Ω	HF45 5680	HF45 5680	820 kΩ	HJ35 8820	HF85 8820
820 Ω	HF45 5820	HF45 5820	1.0 MΩ	HF45 9100	HF45 9100
910 Ω	HF45 5910	HF45 5910	1.2 MΩ	HJ35 9120	*
1.0 kΩ	HF45 6100	HF45 6100	1.5 MΩ	HJ35 9150	HF85 9150
1.2 kΩ	HF45 6120	HF45 6120	1.8 MΩ	HJ35 9180	HF85 9180
1.5 kΩ	HF45 6150	HF45 6150	2.2 MΩ	HJ35 9220	HF85 9220
1.8 kΩ	HF45 6180	HF45 6180	3.3 MΩ	HJ35 9330	HF85 9330
2.0 kΩ	HJ35 6200	HF85 6200	3.9 MΩ	HJ35 9390	*
2.2 kΩ	HF45 6220	HF45 6220	4.7 MΩ	HJ35 9470	HF85 9470
2.4 kΩ	HJ35 6240	HF85 6240			
2.7 kΩ	HF45 6270	HF45 6270			
3.0 kΩ	HF45 6300	HF45 6300			
3.3 kΩ	HF45 6330	HF45 6330			
3.6 kΩ	HJ35 6360	HF85 6360			
3.9 kΩ	HF45 6390	HF45 6390			
4.7 kΩ	HF45 6470	HF45 6470			
5.1 kΩ	HF45 6510	HF45 6510			
5.6 kΩ	HF45 6560	HF45 6560			
6.8 kΩ	HF45 6680	HF45 6680			
8.2 kΩ	HF45 6820	HF45 6820			
9.1 kΩ	HF45 6910	HF45 6910			

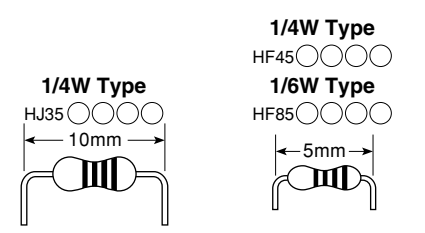

* : Not available

RX-V357/HTR-5830

