

# DIGITAL HOME THEATER SYSTEM YHT-170 AV RECEIVER

# HTR-5920

## SERVICE MANUAL

YHT-170 consists of the HTR-5920 and the NS-P170.

This service manual is for the HTR-5920.

For the NS-P170 service manual, please refer to the following publication number:

NS-P170 101002

### IMPORTANT NOTICE

This manual has been provided for the use of authorized YAMAHA Retailers and their service personnel.

It has been assumed that basic service procedures inherent to the industry, and more specifically YAMAHA Products, are already known and understood by the users, and have therefore not been restated.

**WARNING:** Failure to follow appropriate service and safety procedures when servicing this product may result in personal injury, destruction of expensive components, and failure of the product to perform as specified. For these reasons, we advise all YAMAHA product owners that any service required should be performed by an authorized YAMAHA Retailer or the appointed service representative.

**IMPORTANT:** The presentation or sale of this manual to any individual or firm does not constitute authorization, certification or recognition of any applicable technical capabilities, or establish a principle-agent relationship of any form.

The data provided is believed to be accurate and applicable to the unit(s) indicated on the cover. The research, engineering, and service departments of YAMAHA are continually striving to improve YAMAHA products. Modifications are, therefore, inevitable and specifications are subject to change without notice or obligation to retrofit. Should any discrepancy appear to exist, please contact the distributor's Service Division.

**WARNING:** Static discharges can destroy expensive components. Discharge any static electricity your body may have accumulated by grounding yourself to the ground buss in the unit (heavy gauge black wires connect to this buss).

**IMPORTANT:** Turn the unit OFF during disassembly and part replacement. Recheck all work before you apply power to the unit.

## CONTENTS

TO SERVICE PERSONNEL .....	2	DISPLAY DATA .....	18-19
FRONT PANEL .....	2	IC DATA .....	20-22
REAR PANEL .....	3	PIN CONNECTION DIAGRAMS .....	23-24
REMOTE CONTROL PANEL .....	3	BLOCK DIAGRAM .....	25
SPECIFICATIONS .....	4-6	PRINTED CIRCUIT BOARDS .....	26-30
INTERNAL VIEW .....	6	SCHEMATIC DIAGRAMS .....	31-34
DISASSEMBLY PROCEDURES .....	7-9	REPLACEMENT PARTS LIST .....	35-37
MAINTENANCE FLOW CHART .....	10-17	REMOTE CONTROL .....	38



このサービスマニュアルは、エコマーク認定の再生紙を使用しています。  
This Service Manual uses recycled paper.

101001

© 2006 YAMAHA CORPORATION All rights reserved.  
This manual is copyrighted by YAMAHA and may not be copied or  
redistributed either in print or electronically without permission.



# YAMAHA

YAMAHA CORPORATION  
P.O.Box 1, Hamamatsu, Japan

'06.03

## ■ TO SERVICE PERSONNEL

### 1. Critical Components Information

Components having special characteristics are marked  and must be replaced with parts having specifications equal to those originally installed.

### 2. Leakage Current Measurement (For 120V Models Only)

When service has been completed, it is imperative to verify that all exposed conductive surfaces are properly insulated from supply circuits.

- Meter impedance should be equivalent to 1500 ohms shunted by 0.15μF.

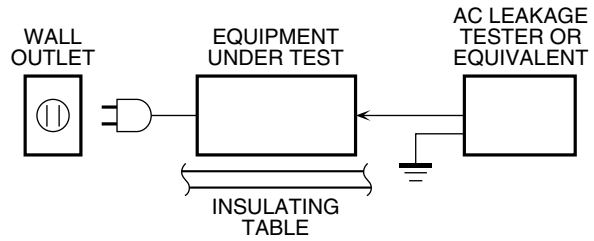

- Leakage current must not exceed 0.5mA.
- Be sure to test for leakage with the AC plug in both polarities.

## WARNING: CHEMICAL CONTENT NOTICE!

The solder used in the production of this product contains LEAD. In addition, other electrical/electronic and/or plastic (where applicable) components may also contain traces of chemicals found by the California Health and Welfare Agency (and possibly other entities) to cause cancer and/or birth defects or other reproductive harm.

DO NOT PLACE SOLDER, ELECTRICAL/ELECTRONIC OR PLASTIC COMPONENTS IN YOUR MOUTH FOR ANY REASON WHATSOEVER!

Avoid prolonged, unprotected contact between solder and your skin! When soldering, do not inhale solder fumes or expose eyes to solder/flux vapor!

If you come in contact with solder or components located inside the enclosure of this product, wash your hands before handling food.

## ■ FRONT PANEL

### U, C models

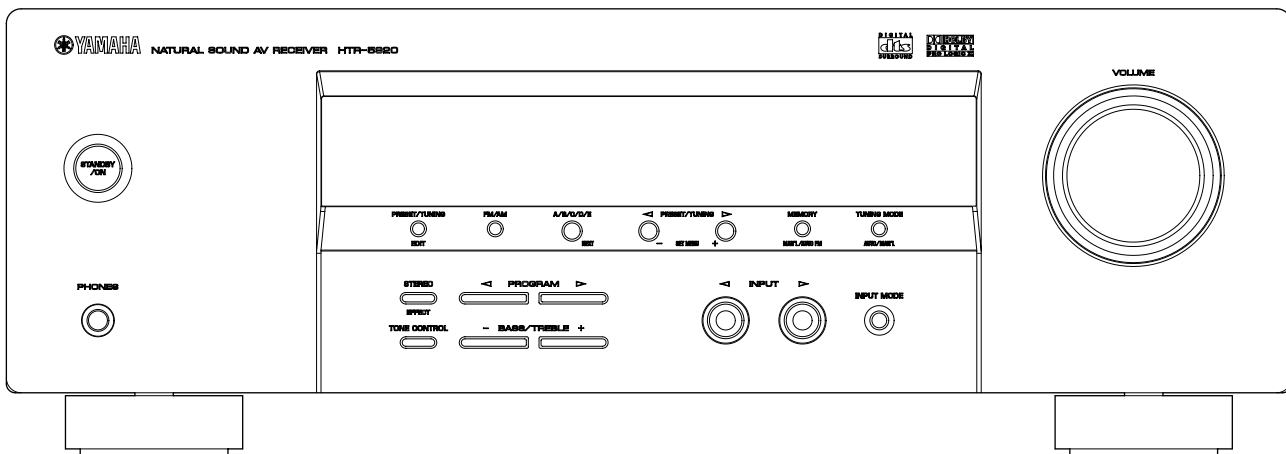

## REAR PANEL

U, C models

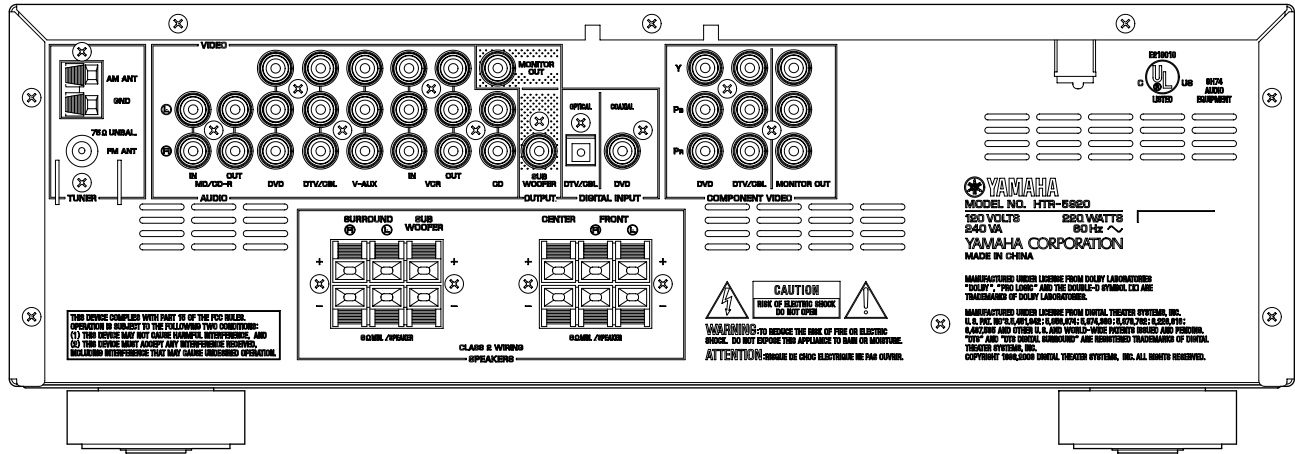

## REMOTE CONTROL PANEL

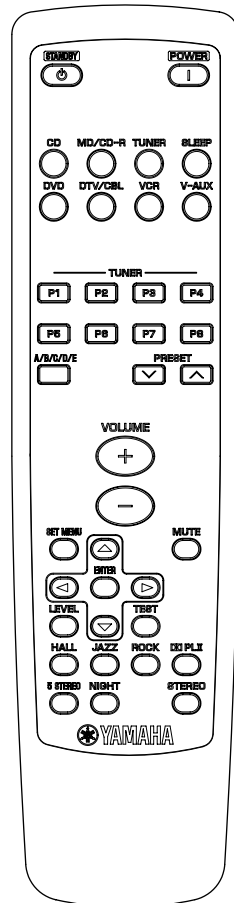

## ■ SPECIFICATIONS

### ■ Audio Section

#### Minimum RMS Output Power Per Channel for FRONT, CENTER and SURROUND

1 kHz, 0.1 % THD, 6 ohms	80 W
1 kHz, 10 % THD, 6 ohms	110 W

#### Frequency Response

CD, etc. to FRONT L/R ..... 10 Hz to 100 kHz, -3 dB

#### Total Harmonic Distortion

1 kHz, CD, etc. to FRONT L/R ..... 0.1 %

#### Signal to Noise Ratio (IHF-A network)

CD, etc. to FRONT L/R, effect off ..... 99 dB

#### Residual Noise (IHF-A network)

..... 150  $\mu$ V

#### Channel Separation (1 kHz / 10 kHz)

CD, etc. (5.1 k-ohms terminated) to FRONT L/R  
..... 60 dB/45 dB or more

#### Tone Control Characteristics (FRONT L/R)

##### BASS

Boost/cut .....  $\pm$ 10 dB (100 Hz)

##### TREBLE

Boost/cut .....  $\pm$ 10 dB (10 kHz)

#### Phones Output

..... 400 mV/470 ohms

#### Input Sensitivity / Input Impedance

CD, etc. .... 200 mV/47 k-ohms

#### Output Level / Output Impedance

REC OUT ..... 200 mV/1.2 k-ohms

### ■ Video Section

#### Video Signal Type

..... NTSC

#### Component Signal Level

..... 1 Vp-p/75 ohms

#### Signal to Noise Ratio

..... 50 dB or more

#### Frequency Response (Monitor out)

Composite ..... 5 Hz to 10 MHz, -3 dB

Component ..... 5 Hz to 60 MHz, -3 dB

### ■ FM Section

#### Tuning Range

..... 87.5 to 107.9 MHz

#### 50dB Quieting Sensitivity (IHF, 100% mod.)

Mono ..... 30 dBf

#### Signal to Noise Ratio (IHF)

Mono/stereo ..... 73 dB/70 dB

#### Harmonic Distortion

(1 kHz)

Mono/stereo ..... 0.5 %/0.8 %

#### Antenna Input

..... 75 ohms unbalanced

### ■ AM Section

#### Tuning Range

..... 530 to 1,710 kHz

#### Antenna

..... Loop antenna

### ■ General

#### Power Supply

U, C models ..... AC 120 V, 60 Hz

#### Power Consumption

U, C models ..... 220 W/240 VA

#### Standby Power Consumption

U, C models ..... 1 W

#### Dimensions (W x H x D)

..... 435 x 151 x 303 mm (17-1/8" x 5-15/16" x 11-15/16")

#### Weight

..... 8.0 kg (17 lbs. 10 oz.)

#### Finish

Silver color ..... U, C models

#### Accessories

Remote control x 1, Batteries (Size "AA", R06, UM-3) x 2, AM loop antenna x 1, Indoor FM antenna x 1

\* Specifications are subject to change without notice due to product improvements.

U ..... U.S.A. model

C .... Canada model



Manufactured under license from Dolby Laboratories.

"Dolby", "Pro Logic", and the double-D symbol are trademarks of Dolby Laboratories.



"DTS", and "DTS Digital Surround" are registered trademarks of Digital Theater Systems, Inc.

#### • DIMENSIONS

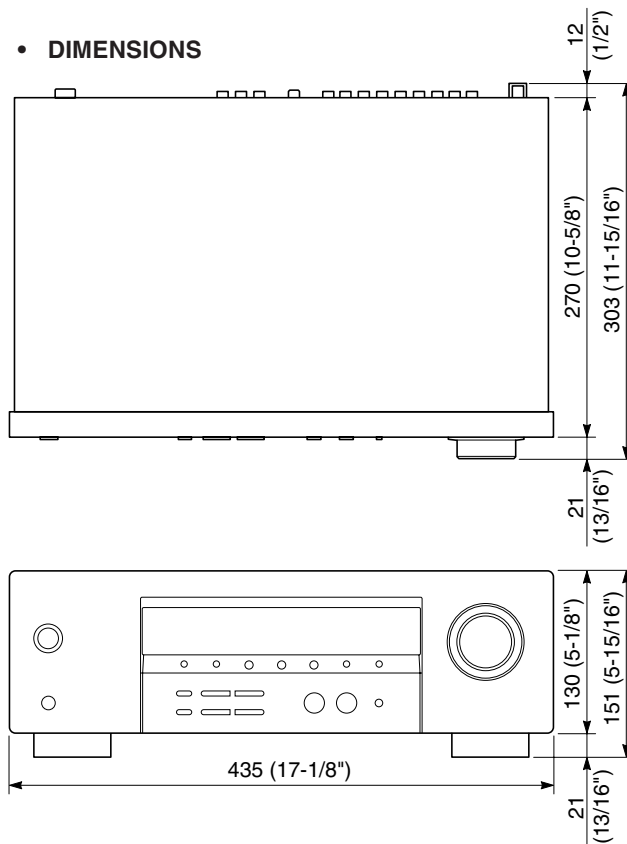

Unit : mm (inch)



### • SET MENU TABLE

MAIN MENU	SELECT MENU	VALUE [INITIAL]
1 SPEAKER LEVEL	FRONT L	-10 dB to +10 dB, [0 dB], 1 dB step
	CENTER	
	FRONT R	
	SURROUND R	
	SURROUND L	
	SUBWOOFER	
2 SPEAKER SET	FRONT	LRG, [SML], NONE
	CENTER	
	SURROUND	[YES], NONE
	SUBWOOFER	
3 SPEAKER DISTANCE	FRONT	1 ft to 30 ft, [10 ft], 1 ft step
	CENTER	
	SURROUND	
4 DIMMER		-2, -1, [0]

### • SURROUND MODE

MAIN MENU	SELECT MENU	VALUE [INITIAL]
PLII MUSIC	PANORAMA	ON, [OFF]
	DIMENSION	-3 to 3, [STD], 1 step
	CT WIDTH	0 to 7, [3], 1 step

### • RESETTING THE SYSTEM

Use this feature to reset all the parameters of this unit to the initial factory settings.

**Note:**

- Be sure this unit is in standby mode.
- This procedure completely resets all the parameters of this unit.
- The initial factory settings are activated next time you turn on this unit.

1. With this unit in standby mode, hold down TONE CONTROL key on the front panel and press STANDBY/ON key. "RESET > NO" appears in the front panel display.

**Note:** To cancel the initialization procedure without making any changes, press STANDBY/ON key.

2. Press TONE CONTROL key to select "RESET > YES".
3. Press STANDBY/ON key to confirm your selection and set this unit to the standby mode.

• **FIRMWARE VERSION** (Microprocessor information)

To display the firmware version, do the following procedure.

1. Press the "STANDBY/ON" key while simultaneously pressing those two keys of the main unit as indicated in the figure below.

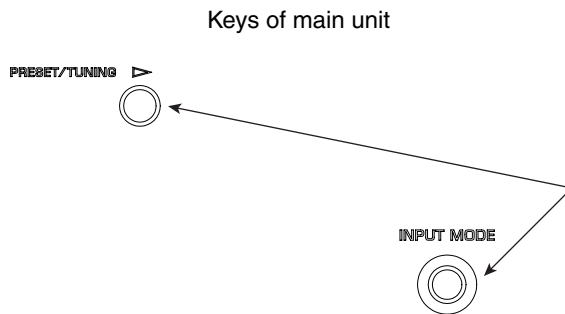

Turn on the power while pressing these keys.

2. 060105-01

\* Numeric values in the figure example are for reference.

3. Press "STANDBY/ON" key.

■ **INTERNAL VIEW**

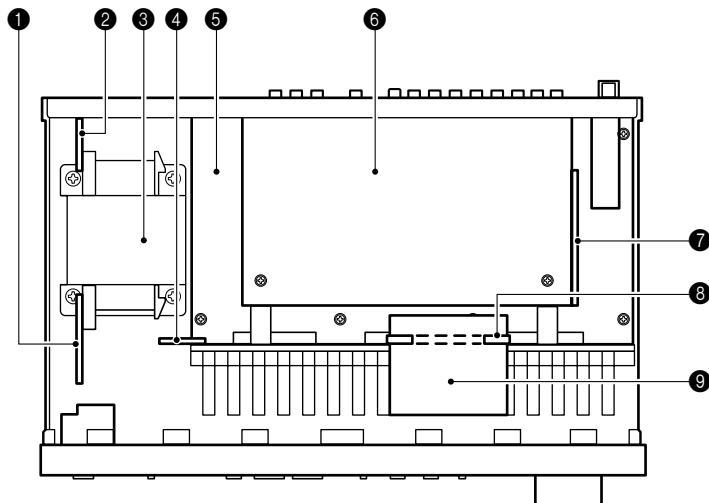

- ① AMP (2) P.C.B.
- ② AMP (3) P.C.B.
- ③ POWER TRANSFORMER
- ④ AMP (7) P.C.B.
- ⑤ AMP (1) P.C.B.
- ⑥ INPUT P.C.B.
- ⑦ AMP (4) P.C.B.
- ⑧ AMP (5) P.C.B.
- ⑨ AMP (6) P.C.B.
- ⑩ FRONT (3) P.C.B.
- ⑪ FRONT (2) P.C.B.
- ⑫ FRONT (1) P.C.B.

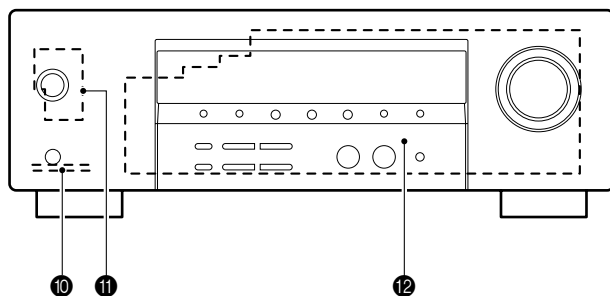

## DISASSEMBLY PROCEDURES

(Remove parts in the order as numbered.)  
Disconnect the power cable from the AC outlet.

### 1. Removal of Top Cover

- Remove 6 screws (①) and 7 screws (②) (Fig. 1)
- Slide the Top Cover rearward to remove it. (Fig. 1)

### 2. Removal of Front Panel Unit

- Remove CN11, CN83, CN96. (Fig. 1)
- Remove 5 screws (③) and 5 screws (④). (Fig. 1)
- Release a hook on the right side of the Front Panel Unit, then remove the Front Panel Unit forward. (Fig. 1)

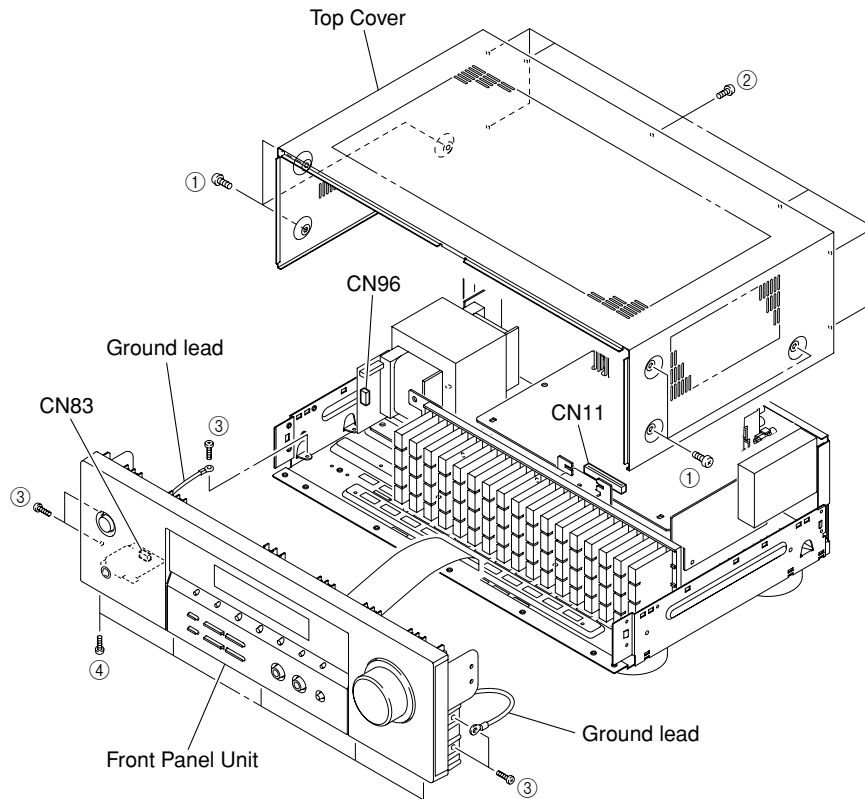
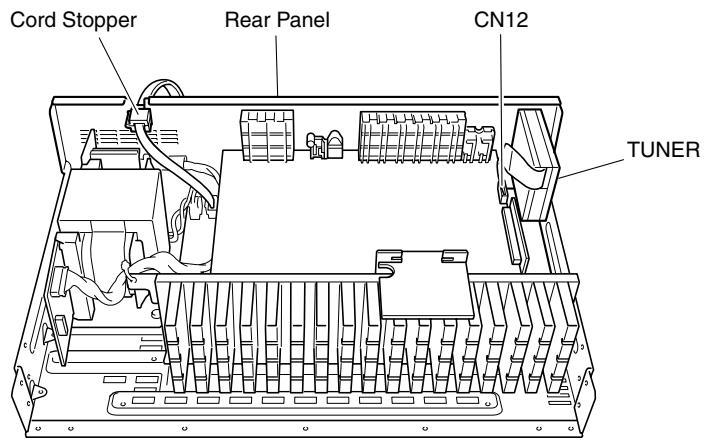

Fig. 1

**3. Removal of Rear Panel and Tuner**

- a. Remove CN12. (Fig. 2)
- b. Remove 2 screws (5). (Fig. 3)
- c. Remove Tuner. (Fig. 2)
- d. Remove 15 screws (6). (Fig. 3)
- e. Remove 2 screws (7). (Fig. 3)
- f. Remove 6 screws (8). (Fig. 4)
- g. Remove Cord Stopper. (Fig. 2)
- h. Remove Rear Panel. (Fig. 2)



**Fig. 2**

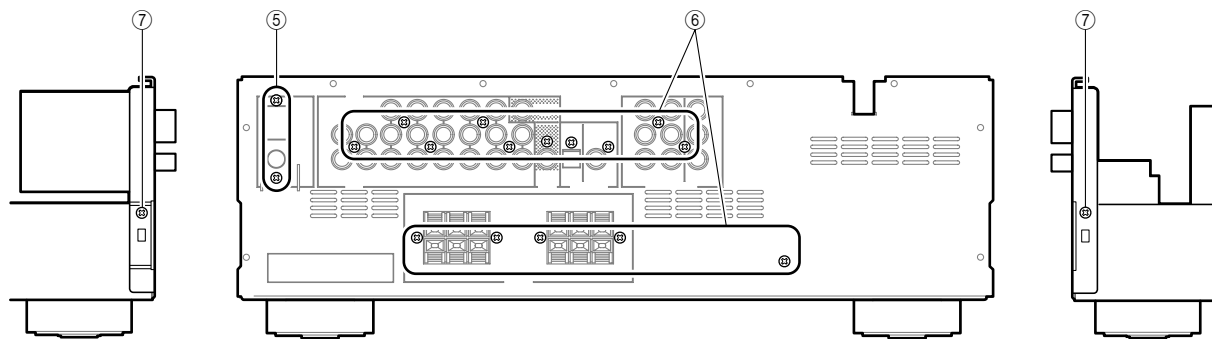

**Fig. 3**

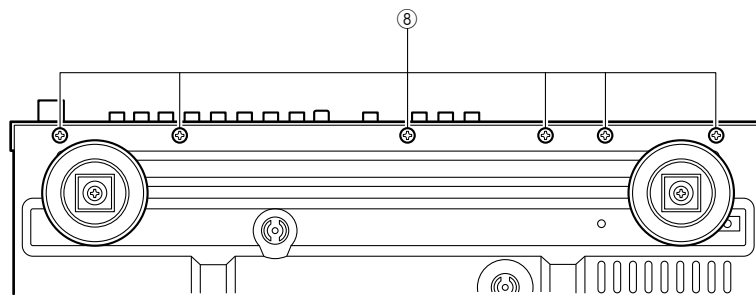

**Fig. 4**

#### 4. Removal of INPUT and AMP (4) P.C.B.s

- a. Remove 1 screw (9) and 2 screws (10). (Fig. 5)
- b. Remove INPUT and AMP (4) P.C.B.s. (Fig. 5)

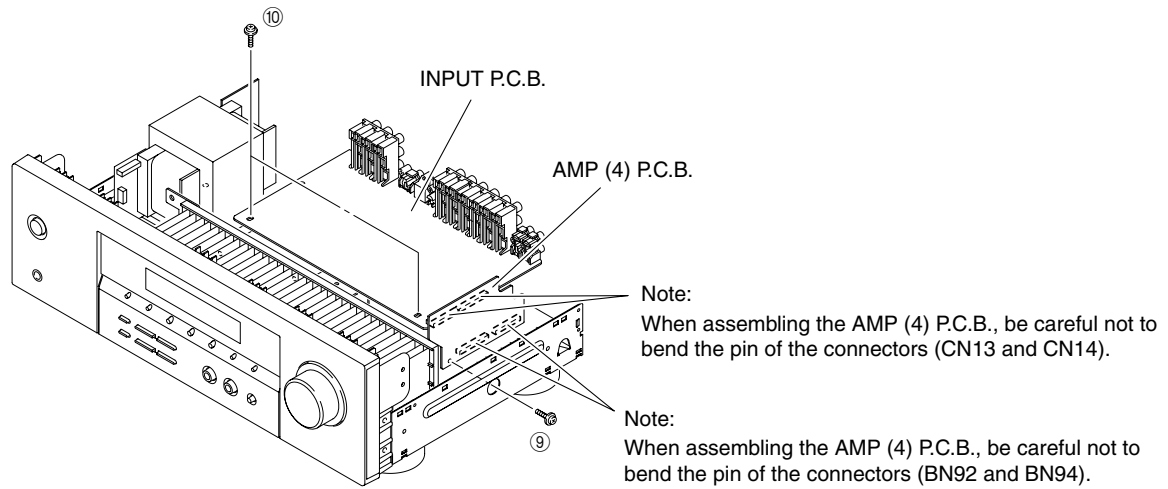

Fig. 5

#### 5. Removal of AMP (1) P.C.B.

- a. Remove 2 screw (11) 5 screws (12) and 3 screw (13). (Fig. 6)
- b. Remove CN90, CN91, CN93 and CN95. (Fig. 6)
- c. Remove AMP (1) P.C.B. with Heat Sink.

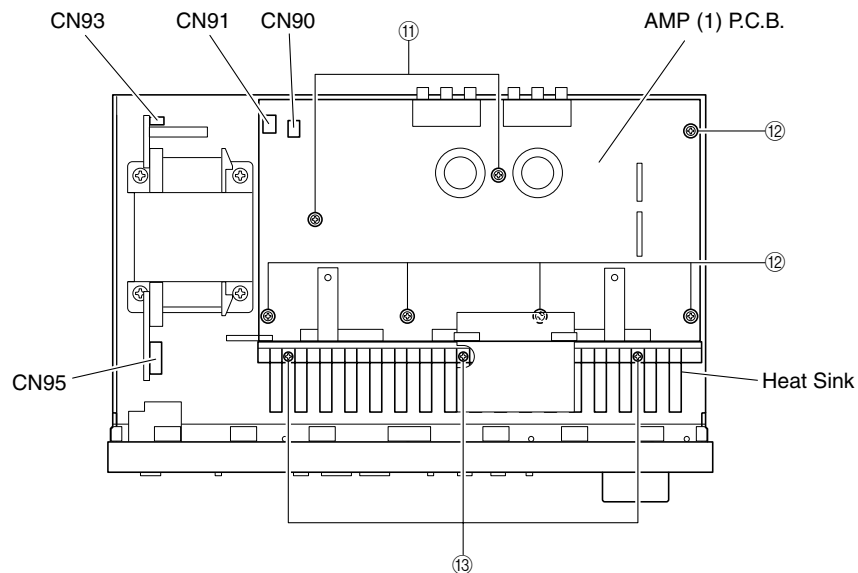
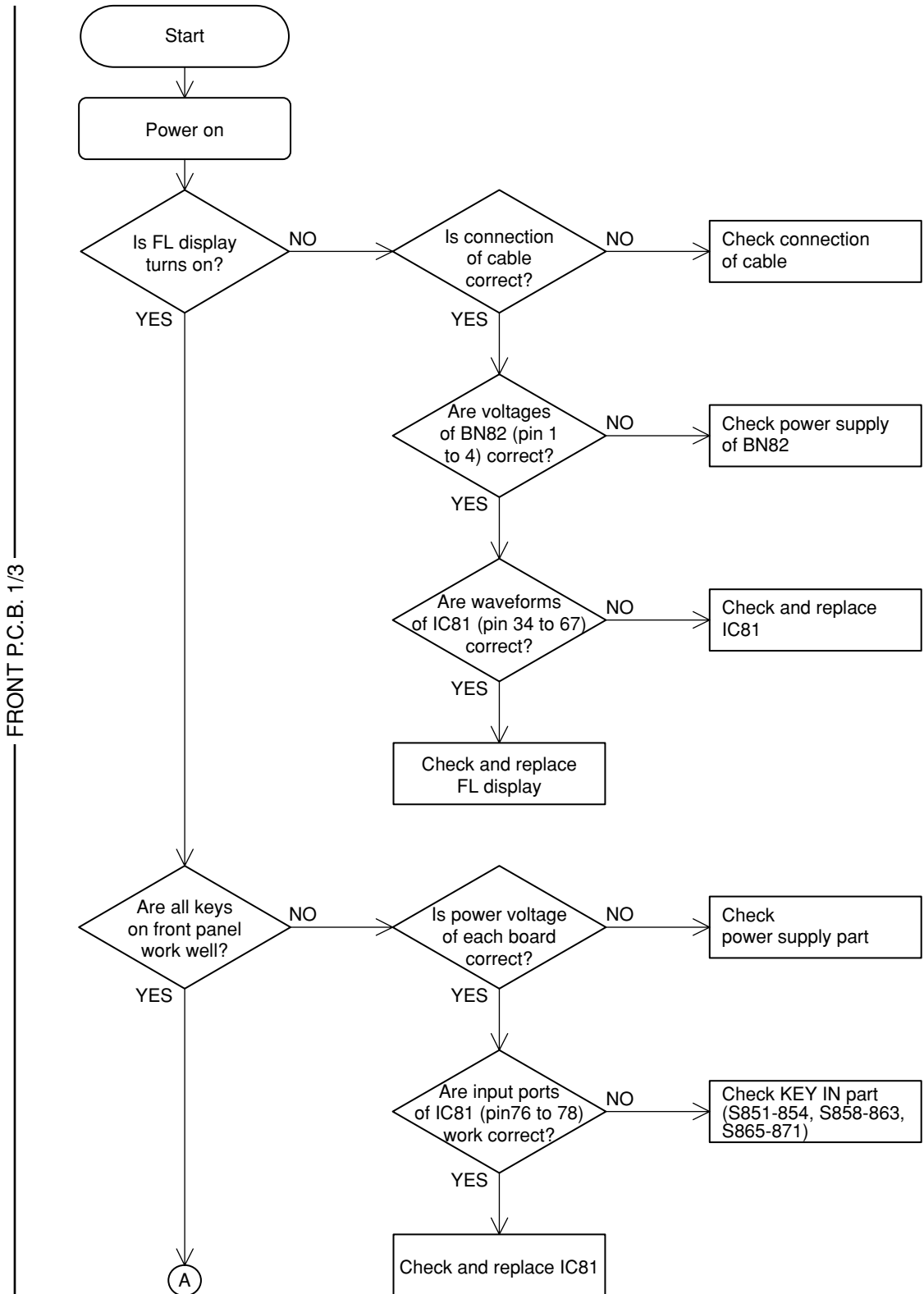

Fig. 6

# MAINTENANCE FLOW CHART

- FRONT P.C.B.



FRONT P.C.B. 2/3

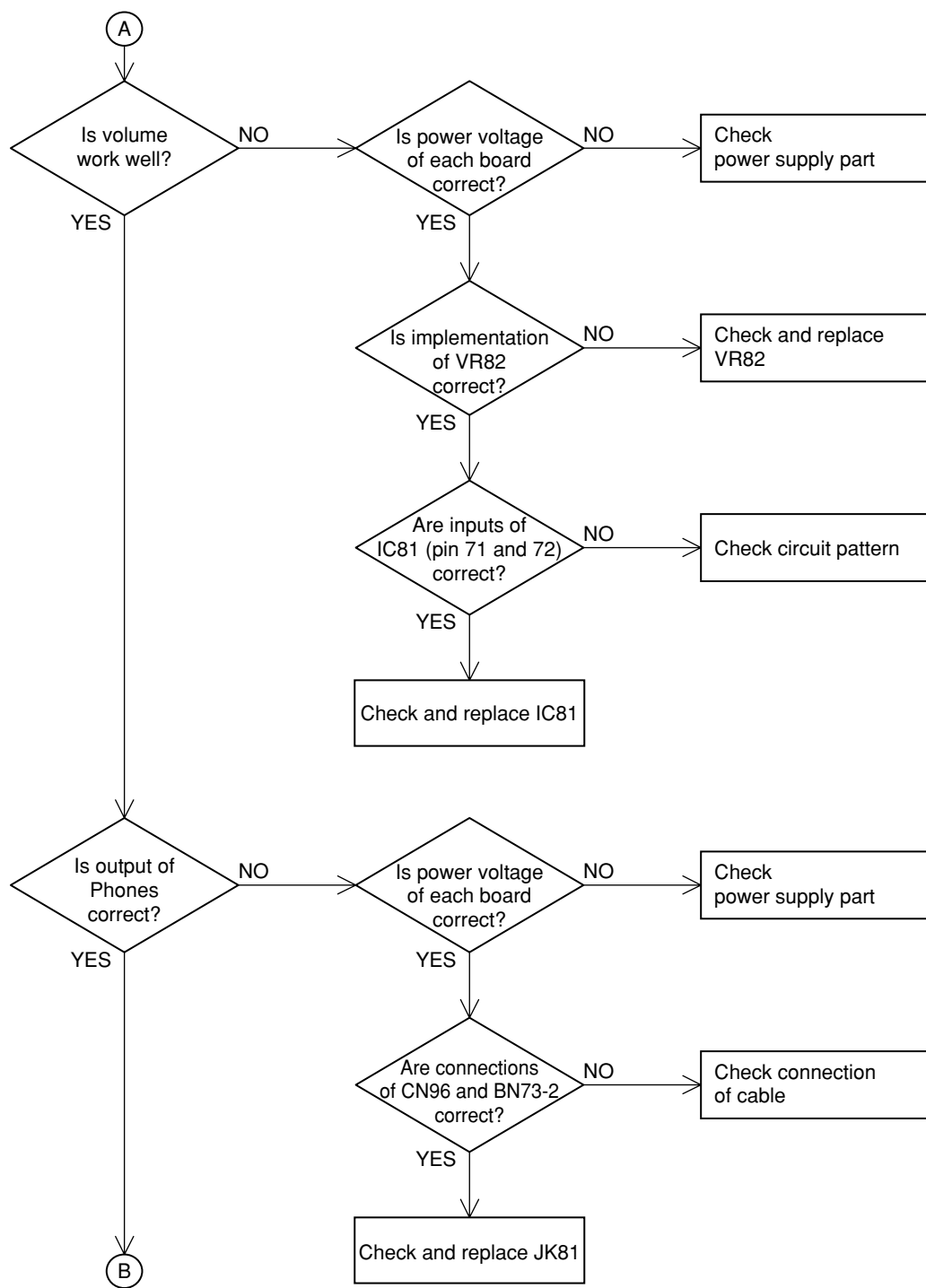

FRONT P.C.B. 3/3

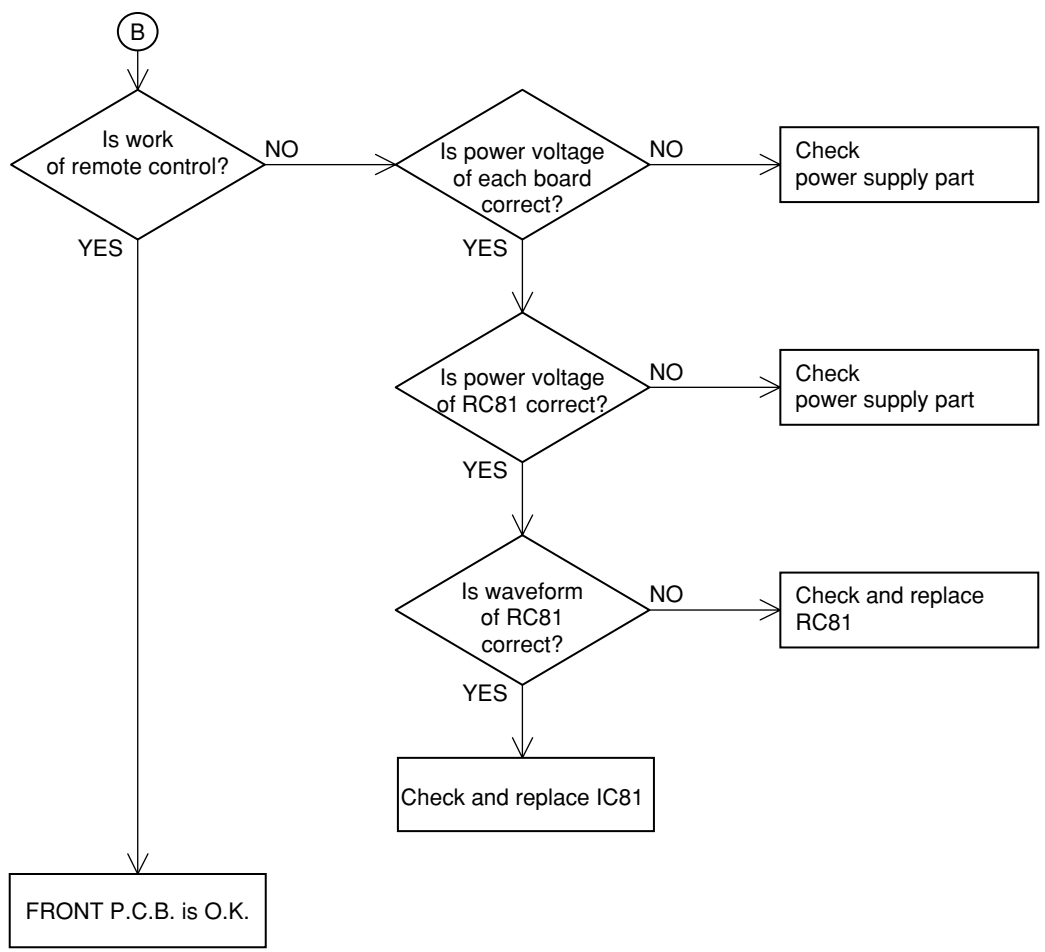



• INPUT P.C.B.

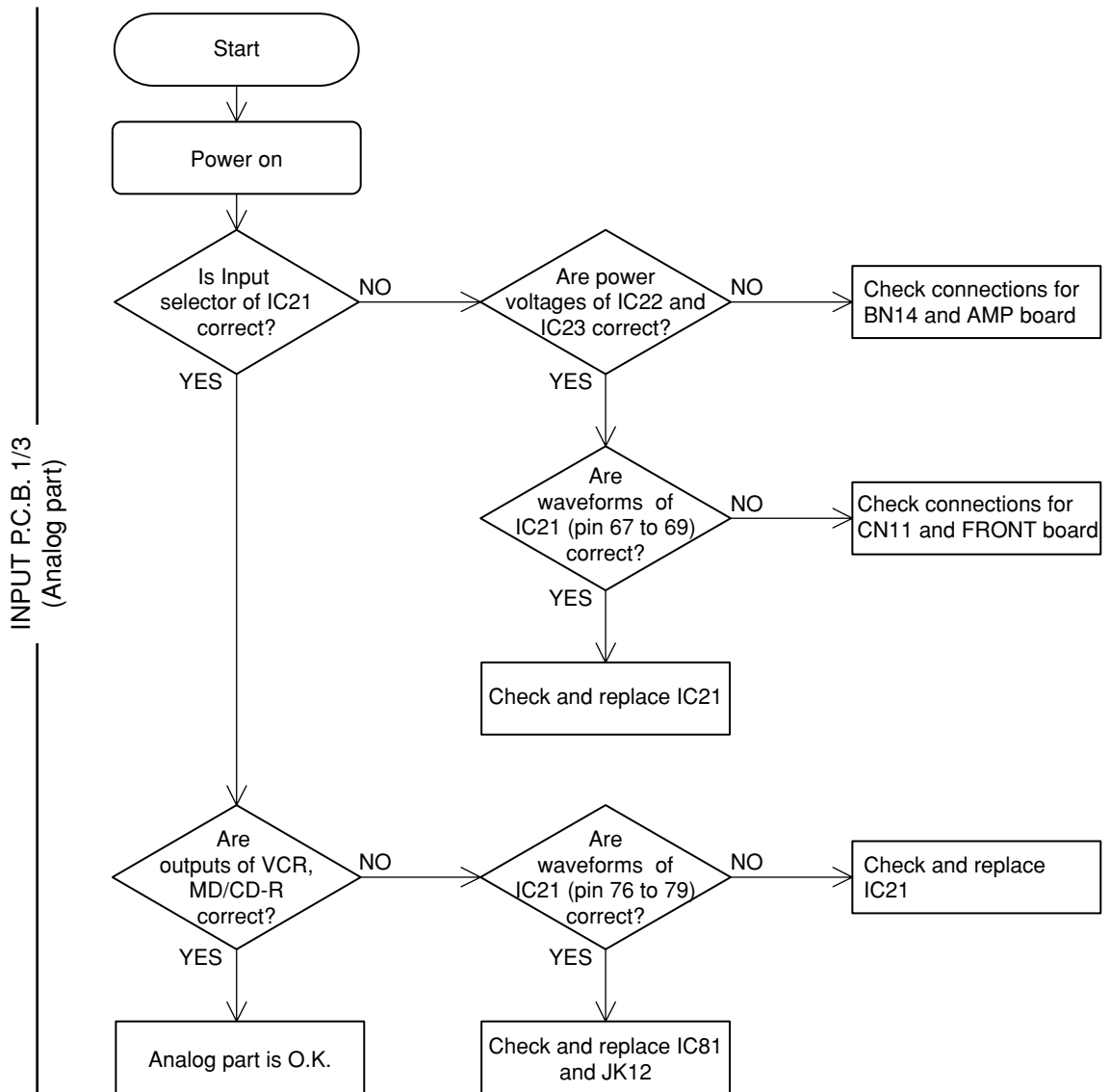

INPUT P.C.B. 2/3  
(Digital part)

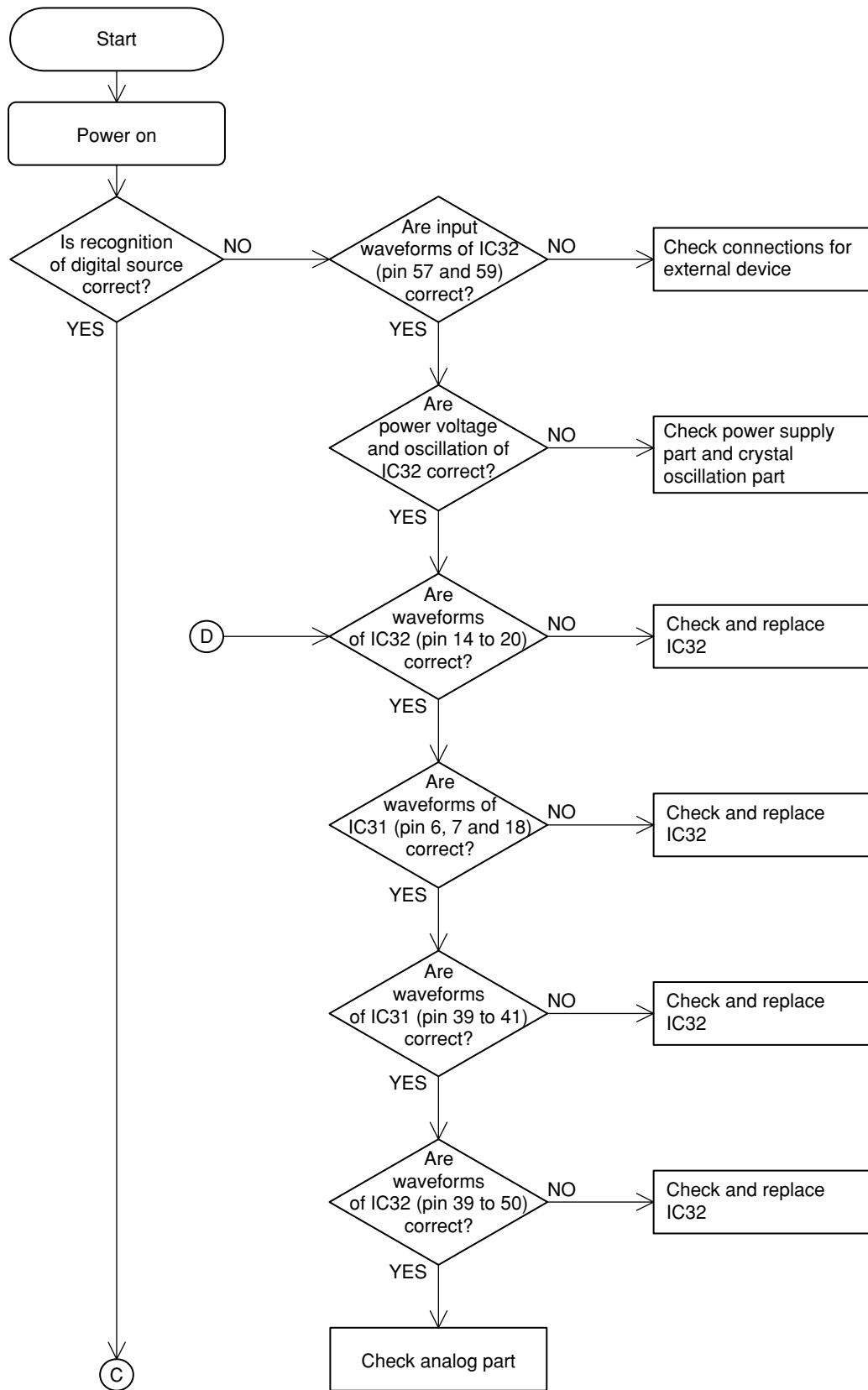

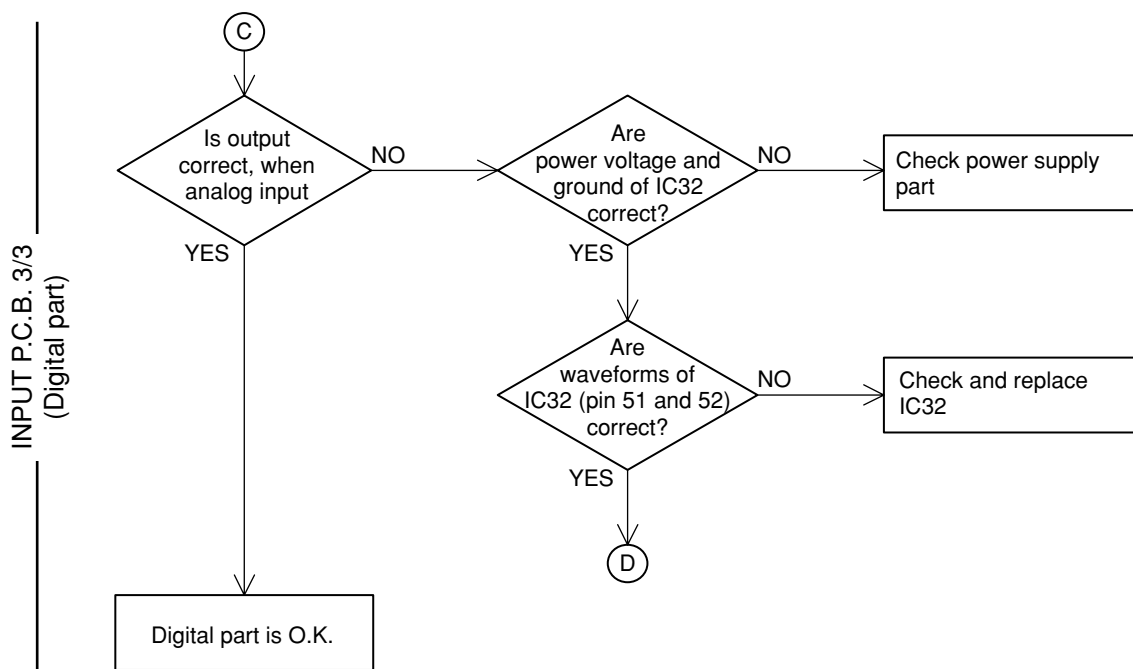

• AMP P.C.B.

AMP P.C.B. 1/2

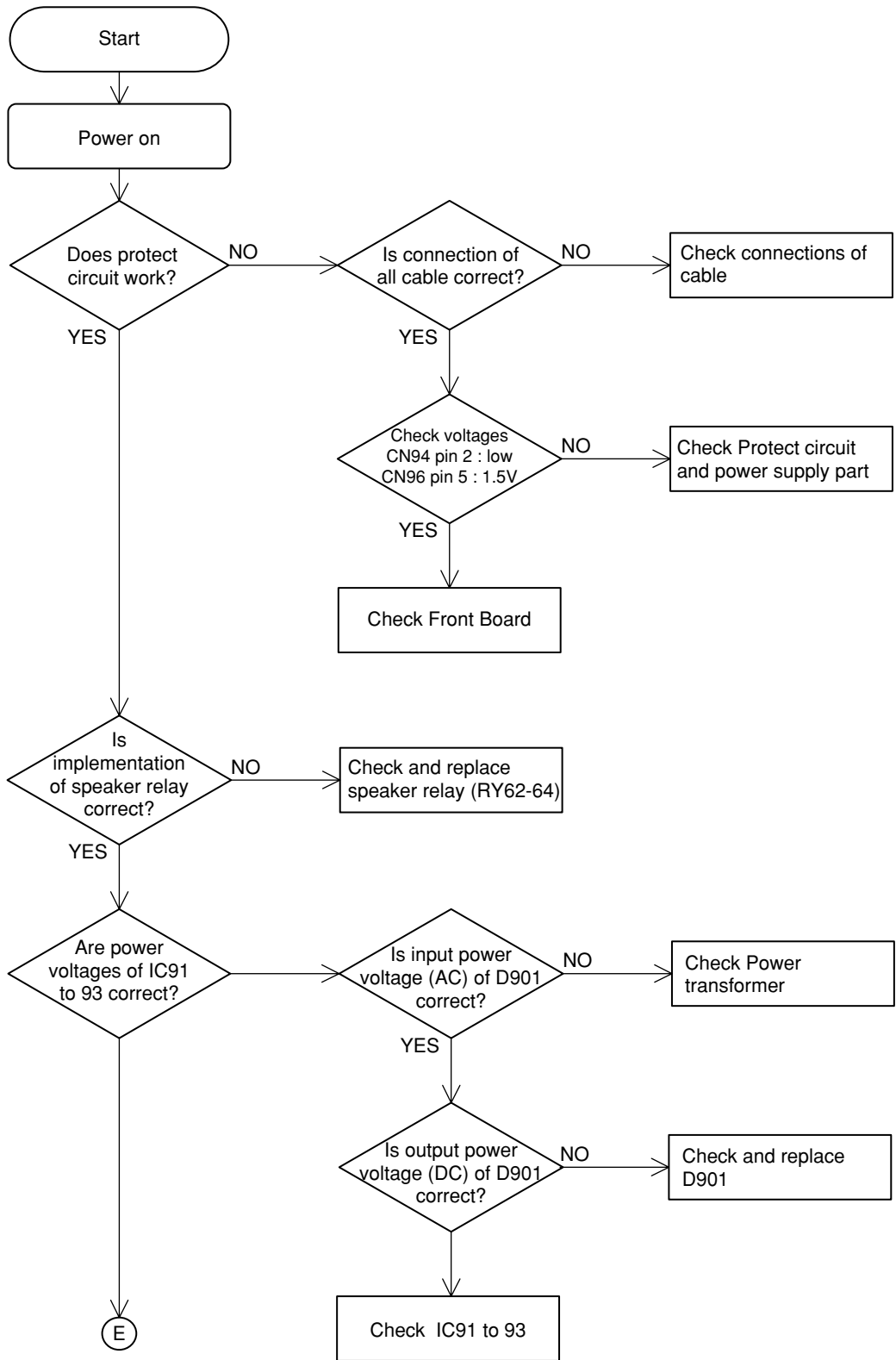

— AMP P. C. B. 2/2 —

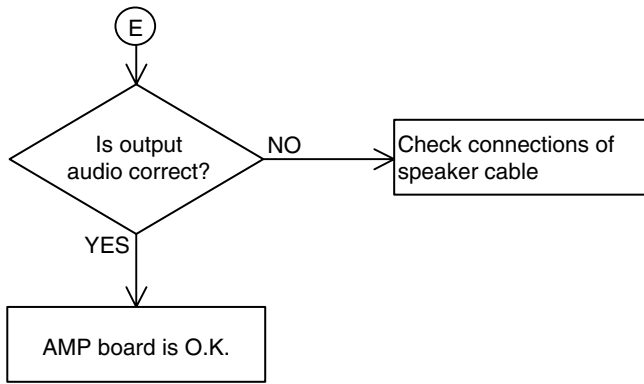

## ■ DISPLAY DATA

### ● HNA-11SM66T

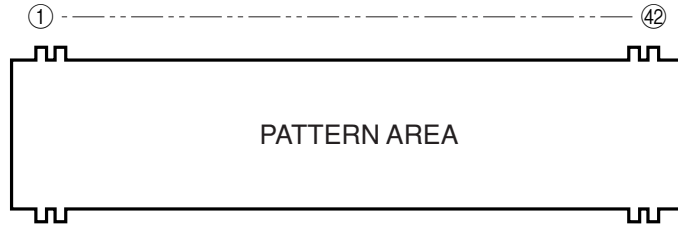

### ● PIN CONNECTION

Pin No.	1	2	3	4	5	6	7	8	9	10	11	12	13	14	15	16	17	18	19	20	21	22	23	24	25	26	27	28	29	30	31	32	33	34	35
Connection	F-	NX	NP	NP	1G	2G	3G	4G	5G	6G	7G	8G	9G	10G	11G	NX	NX	P21	P20	P19	P18	P17	P16	P15	P14	P13	P12	P11	P10	P9	P8	P7	P6	P5	P4

Pin No.	36	37	38	39	40	41	42
Connection	P3	P2	P1	NP	NP	NX	F+

Note : 1) F+, - ..... Filament Pin 2) NP ..... No pin 3) NX ..... No extended pin 4) nG ....Grid Pin 5) Pn ..... Anode Pin

### ● GRID ASSIGNMENT

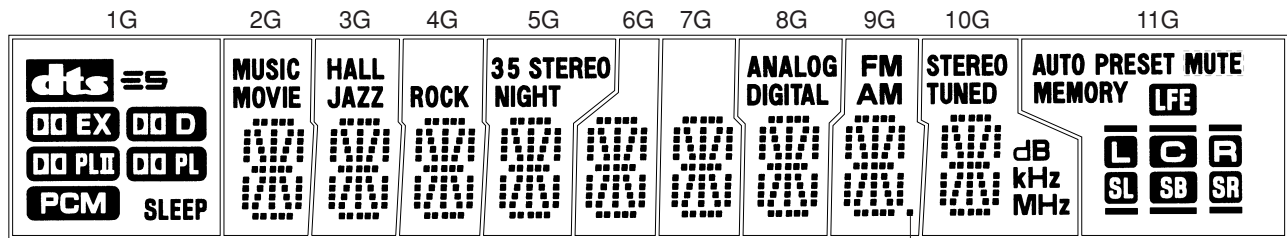

Dp

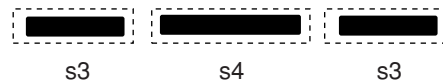
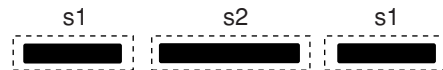
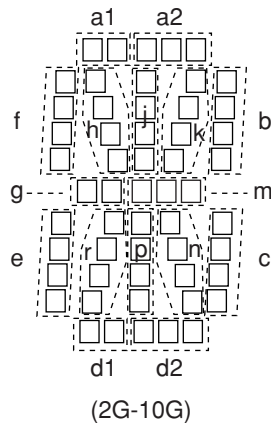

(11G)

● ANODE CONNECTION

	1G	2G	3G	4G	5G	6G	7G	8G	9G	10G	11G
P1	<b>dts</b>	/	/	/	<b>3</b>	/	/	<b>ANALOG</b>	/	<b>STEREO</b>	/
P2	<b>ES</b>	/	/	/	/	/	/	<b>DIGITAL</b>	/	<b>dB</b>	/
P3	<b>EX</b>	f	f	f	f	f	f	f	f	f	<b>L</b>
P4	<b>D</b>	a1	a1	a1	a1	a1	a1	a1	a1	a1	<b>R</b>
P5	<b>PLII</b>	a2	a2	a2	a2	a2	a2	a2	a2	a2	s1
P6	<b>PL</b>	h	h	h	h	h	h	h	h	h	<b>C</b>
P7	<b>PCM</b>	j	j	j	j	j	j	j	j	j	s2
P8	<b>SLEEP</b>	k	k	k	k	k	k	k	k	k	<b>SL</b>
P9	/	b	b	b	b	b	b	b	b	b	<b>SR</b>
P10	/	m	m	m	m	m	m	m	m	m	s3
P11	/	g	g	g	g	g	g	g	g	g	<b>SB</b>
P12	/	e	e	e	e	e	e	e	e	e	s4
P13	/	r	r	r	r	r	r	r	r	r	<b>MUTE</b>
P14	/	p	p	p	p	p	p	p	p	p	<b>MEMORY</b>
P15	/	n	n	n	n	n	n	n	n	n	<b>PRESET</b>
P16	/	c	c	c	c	c	c	c	c	c	<b>LFE</b>
P17	/	d1	d1	d1	d1	d1	d1	d1	d1	d1	<b>AUTO</b>
P18	/	d2	d2	d2	d2	d2	d2	d2	d2	d2	/
P19	/	<b>MUSIC</b>	<b>HALL</b>	/	<b>STEREO</b>	/	/	/	<b>FM</b>	<b>kHz</b>	/
P20	/	<b>MOVIE</b>	<b>JAZZ</b>	<b>ROCK</b>	<b>5</b>	/	/	/	<b>AM</b>	<b>MHz</b>	/
P21	/	/	/	/	<b>NIGHT</b>	/	/	/	Dp	<b>TUNED</b>	/

# IC DATA

IC81: TMP87PS71AF (FRONT P.C.B.)  
Microprocessor

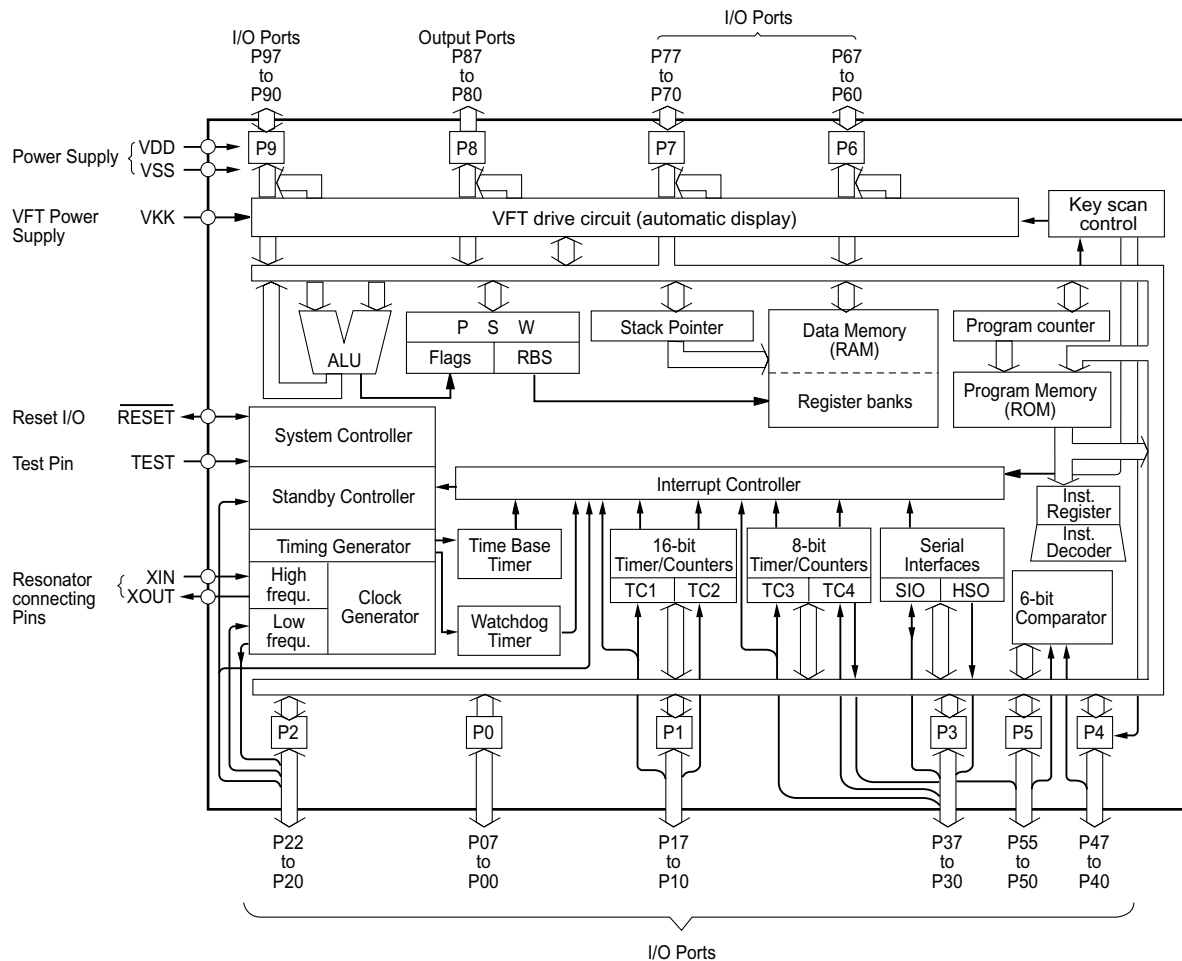
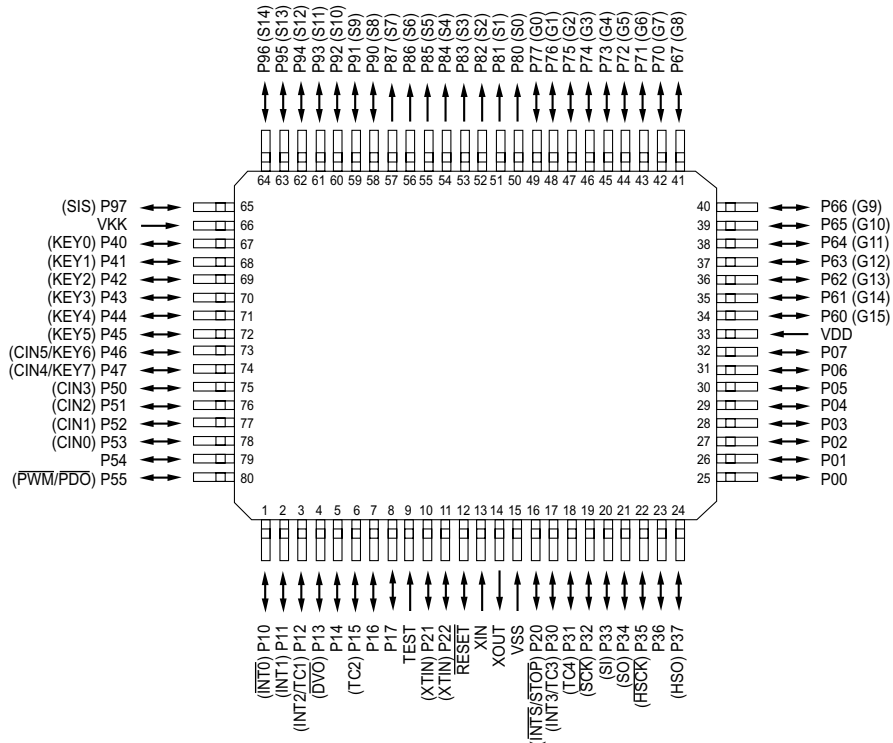



## IC81: TMP87PS71AF (FRONT P.C.B.)

## Microprocessor

No.	PORT ASSIGNMENT		I/O	ACTIVE	REMARKS
	PORT NAME	DESCRIPTION			
1	P10	REMOTE_IN	INPUT	SERIAL DATA	REMOTE DATA INPUT
2	P11	RDS_CLK	INPUT	SERIAL DATA	
3	P12	RDS_DATA	INPUT	SERIAL DATA	
4	P13	PLL_CE	OUTPUT	SERIAL DATA	
5	P14	EXP/PLL_CLK	OUTPUT	SERIAL DATA	PLL CLOCK & CD4094 CLOCK 1
6	P15	EXP/PLL_DATA	OUTPUT	SERIAL DATA	PLL DATA & CD4094 DATA 1
7	P16	N.C	-	-	
8	P17	N.C	-	-	
9	TEST	GND	-	-	
10	P21	EVOL_CE	OUTPUT	SERIAL DATA	NJW1153 (E VOL+FUNCTION SELECT)
11	P22	EVOL_CLK	OUTPUT	SERIAL DATA	NJW1153 (E VOL+FUNCTION SELECT)
12	RESET	RESET	INPUT	-	
13	XIN	X-IN	INPUT	-	OSC FREQUENCY = 8 MHz
14	XOUT	X-OUT	OUTPUT	-	OSC FREQUENCY = 8 MHz
15	VSS	GND	-	-	
16	P20	BACK_UP	INPUT	LOW	CPU ENABLE PORT
17	P30	EVOL_DATA	OUTPUT	SERIAL DATA	NJW1153 (E VOL+FUNCTION SELECT)
18	P31	N.C	-	-	
19	P32	DSP_RST	OUTPUT	SERIAL DATA	
20	P33	DSP_INTREQ	INPUT	SERIAL DATA	DSP: CS493264 , TR INVERT and 1k PULL_UP
21	P34	DSP_DIN	INPUT	SERIAL DATA	DSP: CS493264 , TR INVERT and 1k PULL_UP
22	P35	DSP/CODEC_CLK	OUTPUT	SERIAL DATA	
23	P36	DSP_CS	OUTPUT	SERIAL DATA	
24	P37	DSP/CODEC_DATA	OUTPUT	SERIAL DATA	
25	P00	CODEC_CS	OUTPUT	SERIAL DATA	
26	P01	CODEC_RESET	OUTPUT	SERIAL DATA	
27	P02	PLL_DIN	INPUT	SERIAL DATA	
28	P03	POWER_ON	OUTPUT	HIGH	
29	P04	EXP_CLK2	OUTPUT	SERIAL DATA	CD4094 CLOCK 2
30	P05	EXP_DATA2	OUTPUT	SERIAL DATA	CD4094 DATA 2
31	P06	EXP_CE2	OUTPUT	SERIAL DATA	CD4094 CHIP ENABLE 2
32	P07	FUN_MUTE	OUTPUT	LOW	
33	VDD	VDD	-	-	
34 to 54		SEG 1 to SEG 21	OUTPUT	SERIAL DATA	VFD = 11-BT-230GNK
55 to 65		GRID 11 to GRID 1	OUTPUT	SERIAL DATA	VFD = 11-BT-230GNK
66	VKK	VKK	-	-	VFD = 11-BT-230GNK
67	P40	OPTION	INPUT	-	
68	P41	H/PHONE_IN	INPUT	LOW	EXTERNAL +5V PULL_UP
69	P42	TUNED	INPUT	LOW	
70	P43	STEREO	INPUT	LOW	
71	P44	VOL_UP	INPUT		EXTERNAL +5V PULL_UP
72	P45	VOL_DOWN	INPUT		EXTERNAL +5V PULL_UP
73	P46	LEVEL_IN	INPUT	HIGH	
74	P47	PROTECT_IN	INPUT	LOW	
75	P50	PROTECT_IN	INPUT		
76	P51	KEY_IN3	INPUT		EXTERNAL +5V PULL_UP
77	P52	KEY_IN1	INPUT		EXTERNAL +5V PULL_UP
78	P53	KEY_IN2	INPUT		EXTERNAL +5V PULL_UP
79	P54	N.C	-		
80	P55	EXP_CE1	OUTPUT	SERIAL DATA	CD4094 CHIP ENABLE 1

IC24: CD4094B (INPUT P.C.B.)  
8-stage shift and store bus register

PIN No.	PORT ASSIGNMENT		SHIFT REGISTER
	PORT NAME	DESCRIPTION	
1	STROBE	STROBE INPUT	CHIP ENABLE 1 FROM MICROPROCESSOR PIN No. 80
2	DATA	DATA INPUT	DATA INPUT 1 FROM MICROPROCESSOR PIN No. 6
3	CLOCK	CLOCK INPUT	CLOCK INPUT 1 FROM MICROPROCESSOR PIN No. 5
4	Q1	OUTPUT	COMPONENT VIDEO SW_2
5	Q2	OUTPUT	COMPONENT VIDEO SW_1
6	Q3	OUTPUT	VIDEO MUTE_1
7	Q4	OUTPUT	VIDEO MUTE_2
8	VSS	VSS	
9	QS	N.C.	
10	Q'S	N.C.	
11	Q8	OUTPUT	VIDEO SW_1
12	Q7	OUTPUT	VIDEO SW_2
13	Q6	OUTPUT	REC MUTE_1
14	Q5	OUTPUT	REC MUTE_2
15	OUTPUT ENABLE	OUTPUT ENABLE	
16	VDD	VDD	

IC94: CD4094B (AMP P.C.B.)  
8-stage shift and store bus register

PIN No.	PORT ASSIGNMENT		SHIFT REGISTER
	PORT NAME	DESCRIPTION	
1	STROBE	STROBE INPUT	CHIP ENABLE 2 FROM MICROPROCESSOR PIN No. 31
2	DATA	DATA INPUT	DATA INPUT 2 FROM MICROPROCESSOR PIN No. 30
3	CLOCK	CLOCK INPUT	CLOCK INPUT 2 FROM MICROPROCESSOR PIN No. 29
4	Q1	OUTPUT	N.C.
5	Q2	OUTPUT	FRONT SPEAKER ON
6	Q3	OUTPUT	SURROUND MUTE
7	Q4	OUTPUT	CENTER MUTE
8	VSS	VSS	
9	QS	N.C.	
10	Q'S	N.C.	
11	Q8	OUTPUT	PRE SUBWOOFER MUTE
12	Q7	OUTPUT	HEADPHONE RELAY ON
13	Q6	OUTPUT	SURROUND SPEAKER ON
14	Q5	OUTPUT	CENTER SPEAKER ON
15	OUTPUT ENABLE	OUTPUT ENABLE	
16	VDD	VDD	

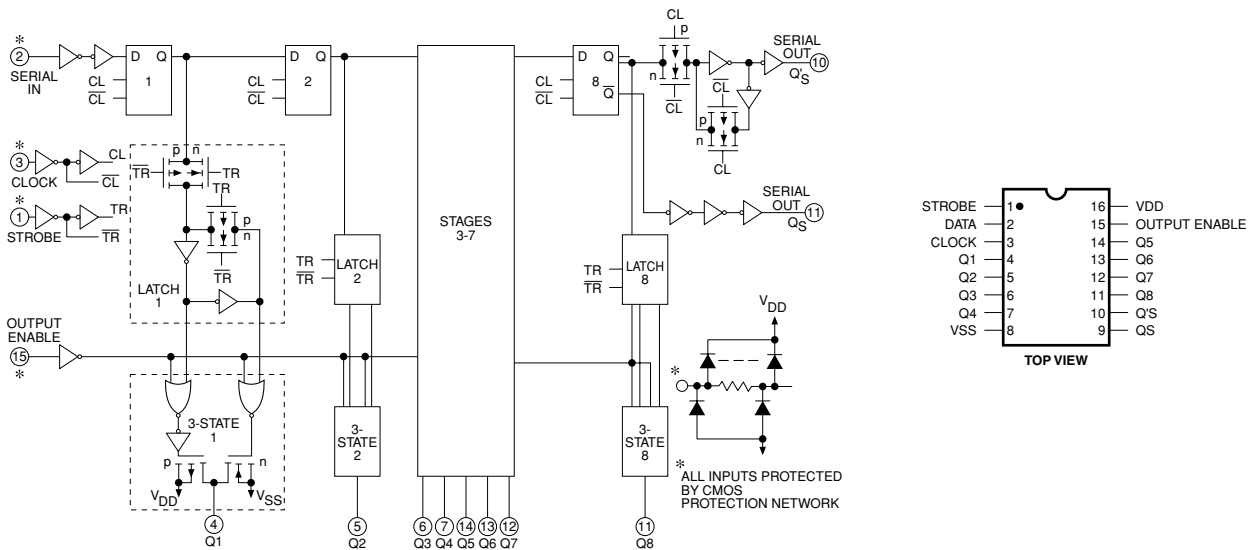

# PIN CONNECTION DIAGRAMS

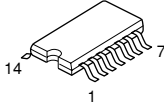
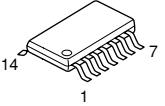
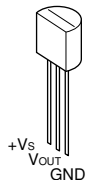
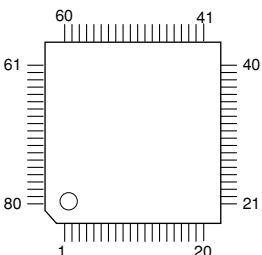
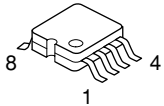
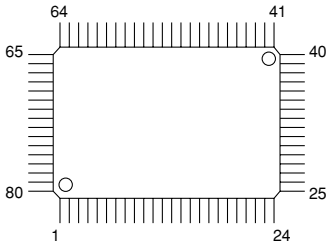
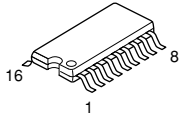
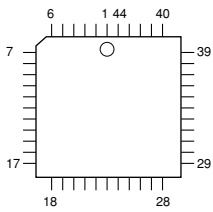
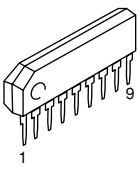
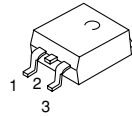
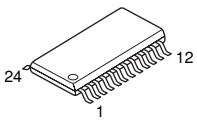
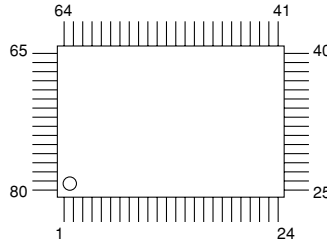
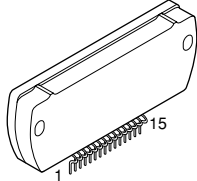
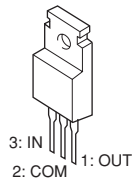

## • ICs

<p>74HCU04</p> 	<p>74LCX08</p> 	<p>78L08</p> 	<p>AK4589</p> 
<p>BA4560RF</p> 	<p>BD3816K1</p> 	<p>CD4094</p> 	<p>CS493264</p> 
<p>LA7952</p> 	<p>MC7805C</p> 	<p>NJM2586</p> 	<p>TMP87PS71</p> 
<p>BVISTK402-120SE-HYBRID(ROHS)</p> 	<p>HVIKIA7812API HVIKIA7912PI</p> 		

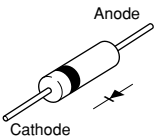
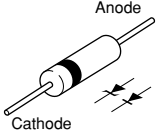
## • Diodes

<p>1N4003 1N4403S 1SS133 DQ10 UF4004</p> 	<p>HVDMTZJ4.3BT HVDMTZJ4.7BT HVDMTZJ5.1BT HVDMTZJ33BT</p> 	
--	--	--

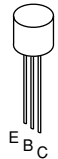
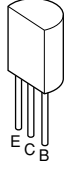
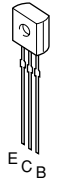
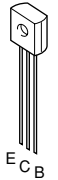
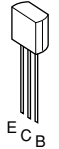
• Transistors

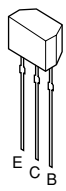
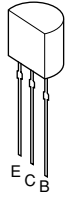
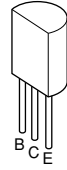
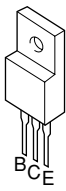
<p>2SA102M</p> 	<p>2SA1271Y</p> 	<p>2SB811Y</p> 	<p>2SC2785 2SC2785Y</p> 	<p>2SC3199 2SC3200</p> 
<p>2SB811Y 2SC2785Y KTD1304</p> 	<p>KRA102MT KRC102MT KRC114MT KTA1267YT KTC3199YT</p> 	<p>KTA1268GRT KTC2874BT</p> 	<p>KTC3198Y</p> 	<p>KTD2058Y</p> 

# 1 ■ BLOCK DIAGRAM

**INPUT** • See page 31, 32 → SCHEMATIC DIAGRAM

**AMP** • See page 33 → SCHEMATIC DIAGRAM

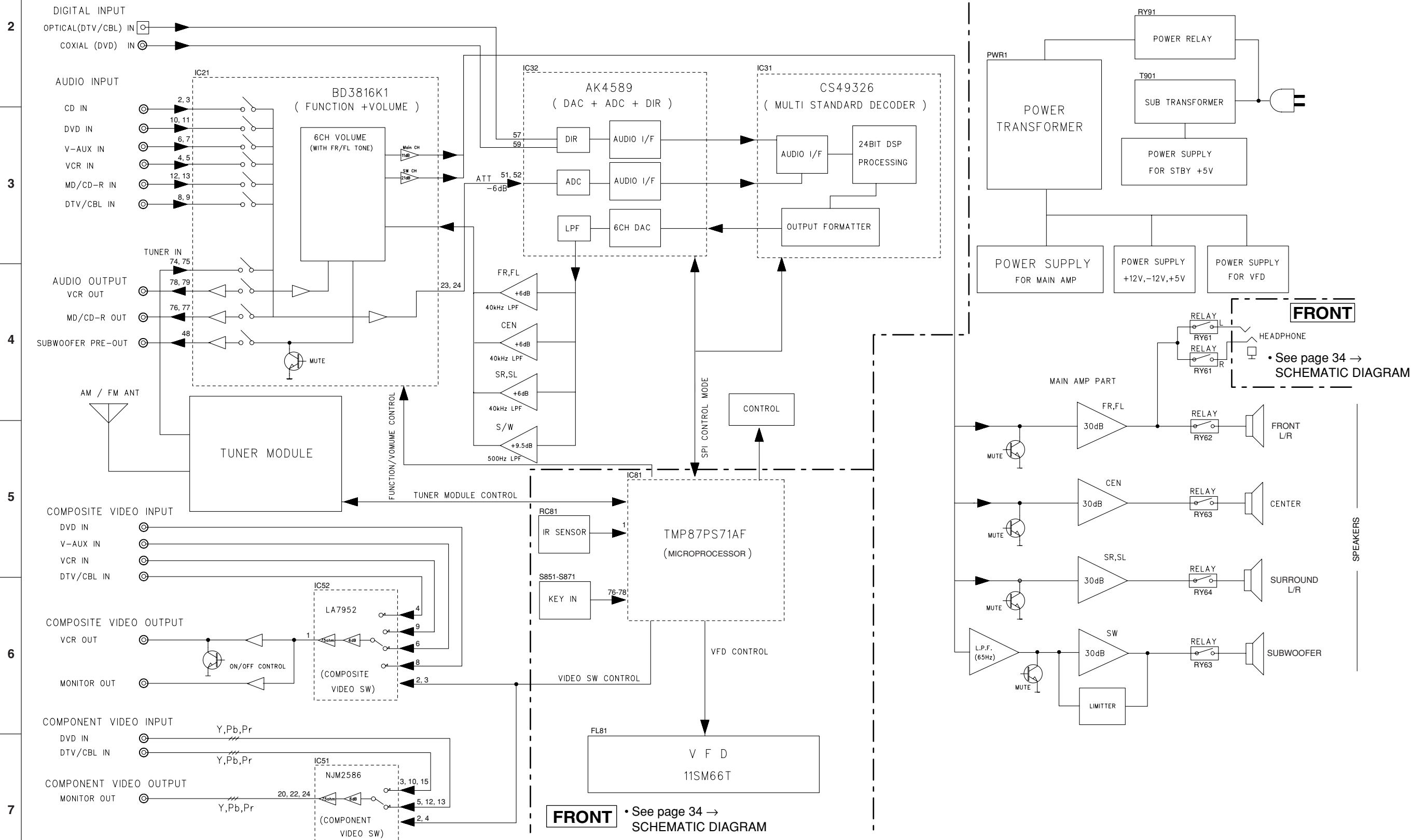

**FRONT** • See page 34 → SCHEMATIC DIAGRAM

**FRONT** • See page 34 → SCHEMATIC DIAGRAM





**INPUT P.C.B.** (Side B)

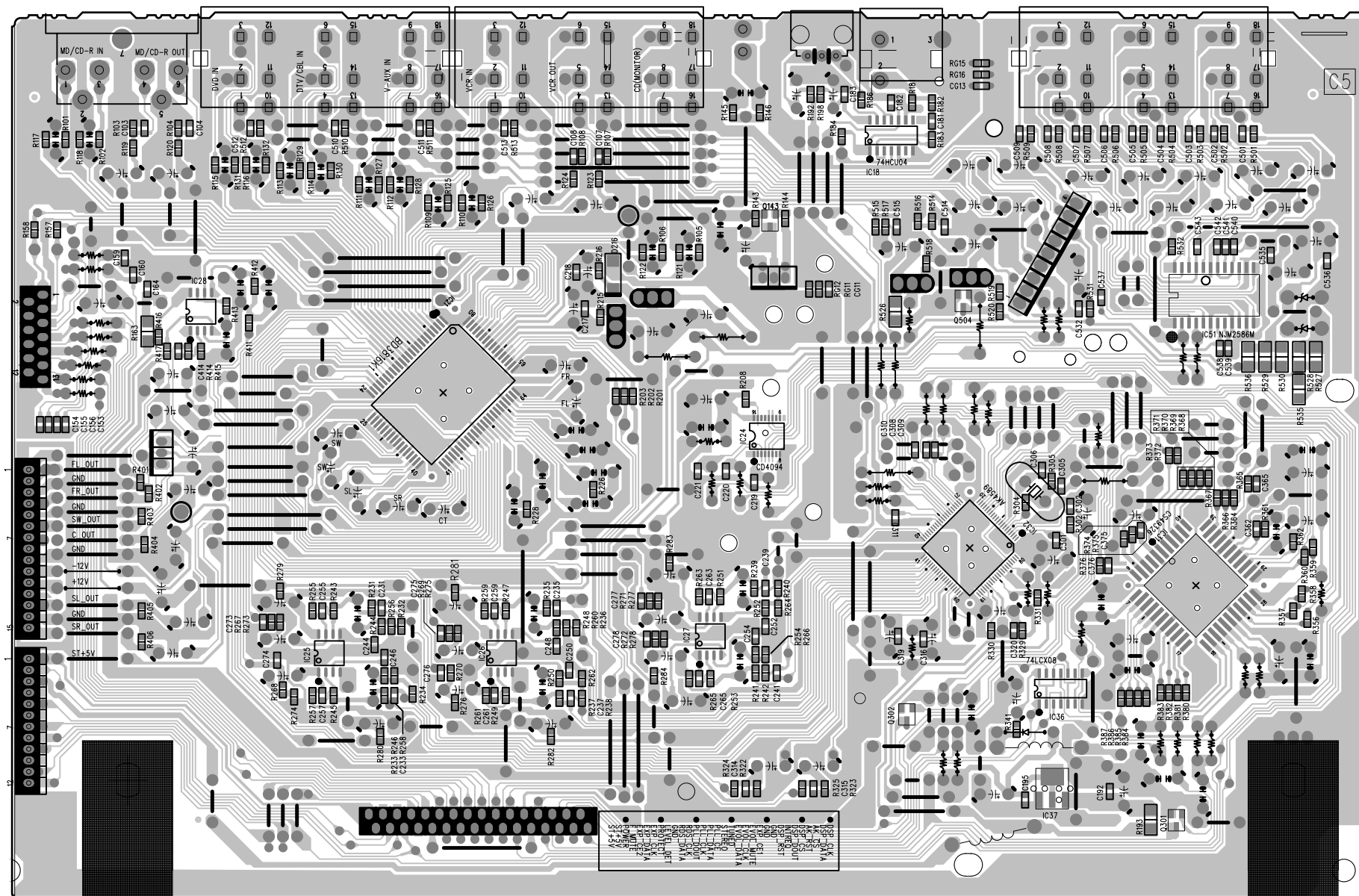

• Semiconductor Location

Ref no.	Location
IC18	F3
IC21	D4
IC24	E4
IC25	C5
IC26	D5
IC27	E5
IC28	C4
IC31	G5
IC32	F5
IC36	G6
IC37	G6
IC51	G4
Q143	E3
Q301	G6
Q302	F6
Q504	F4

AMP (1) P.C.B. (Side A)

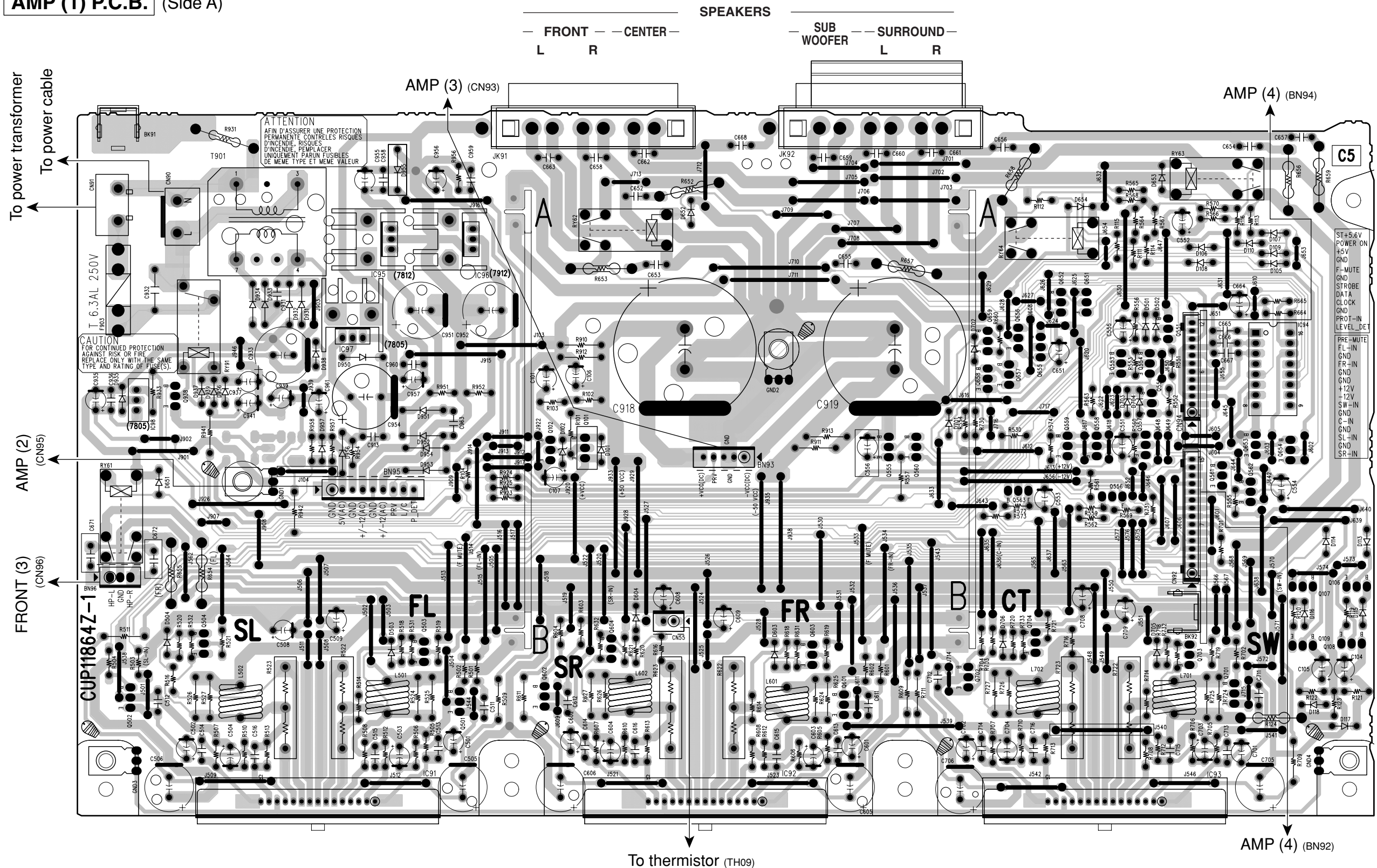

• Semiconductor Location

Ref no.	Location	Ref no.	Location
D101	D4	IC92	E6
D102	D4	IC93	G6
D105	I3	IC94	H4
D106	H3	IC95	C3
D107	I3	IC96	D3
D108	H3	IC97	C4
D109	I3	IC98	B4
D110	H3	Q101	D4
D113	I5	Q102	D4
D114	I5	Q106	I5
D115	I5	Q107	I5
D116	I5	Q108	I5
D117	I6	Q109	I5
D118	I6	Q501	D6
D501	H4	Q502	A6
D502	H4	Q503	C5
D503	C5	Q504	B5
D504	B5	Q551	H4
D603	E5	Q552	H4
D604	E5	Q553	H4
D651	B4	Q554	H4
D652	E3	Q555	H4
D653	H3	Q556	H4
D654	G3	Q557	H4
D701	G4	Q558	G4
D702	G4	Q559	G4
D703	H4	Q560	F4
D704	H4	Q561	G3
D705	H5	Q562	G3
D706	G5	Q563	G4
D931	C3	Q601	F6
D932	B3	Q602	D6
D933	B3	Q603	F5
D934	B3	Q604	D5
D935	A4	Q651	H4
D936	B4	Q652	H4
D937	B4	Q653	H4
D938	C4	Q654	I4
D939	B4	Q655	G4
D950	C4	Q656	G3
D951	C4	Q657	G4
D952	C4	Q658	G4
D953	C4	Q659	G3
D954	C4	Q701	H6
D955	C2	Q702	G6
D956	C4	Q703	H5
D957	C4	Q704	G5
IC91	C6	Q938	B4



**AMP (2) P.C.B.** (Side A)

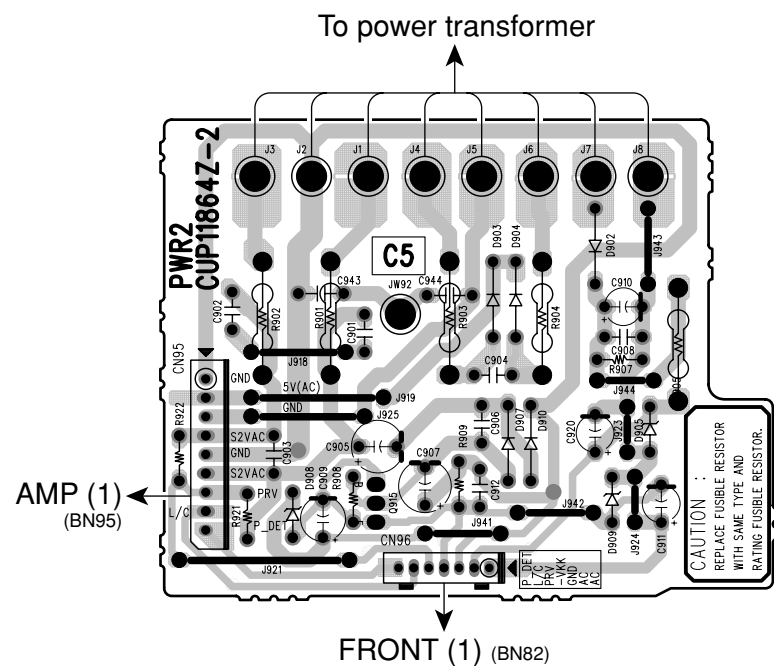

**AMP (3) P.C.B.** (Side A)

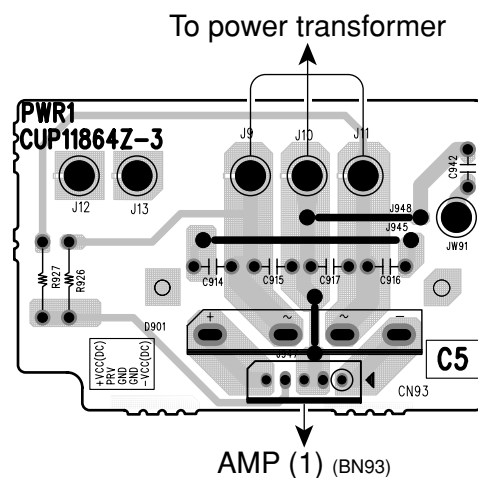

**AMP (4) P.C.B.** (Side A)

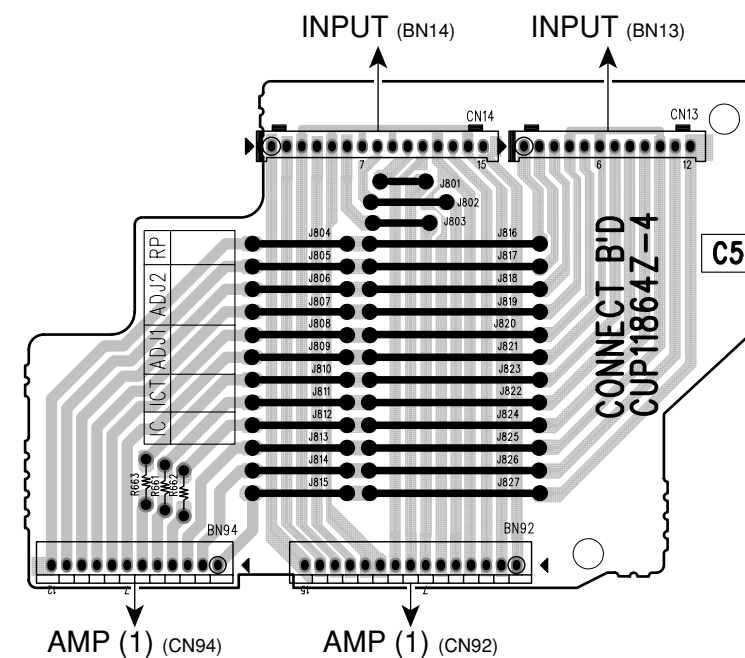

**FRONT (1) P.C.B. (Side A)**

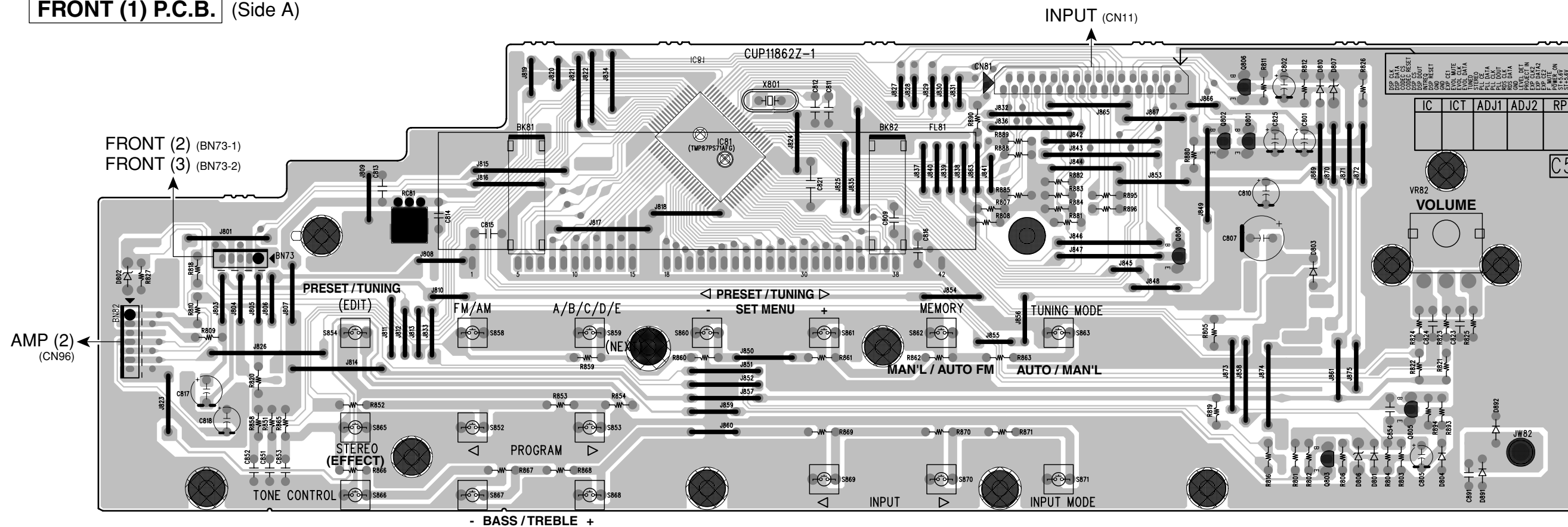

**FRONT (2) P.C.B. (Side A)**

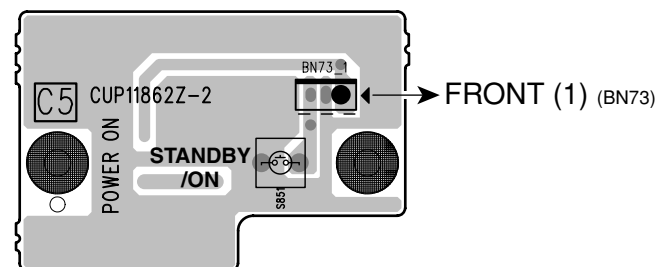

**FRONT (3) P.C.B. (Side A)**

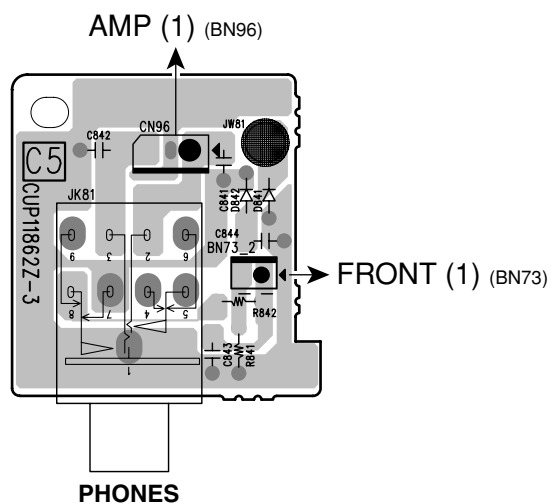

• Semiconductor Location

Ref no.	Location
D801	I4
D802	B3
D803	H3
D804	I4
D806	I4
D807	H2
D810	H2
D841	F6
D842	F6
D891	I4
D892	I4
IC81	E2
Q801	H2
Q802	H2
Q803	H4
Q805	I4
Q806	H2
Q808	G3

# SCHEMATIC DIAGRAMS INPUT 1/2

1  
2  
3  
4  
5  
6  
7  
8  
9

AUDIO / VIDEO  
DIGITAL

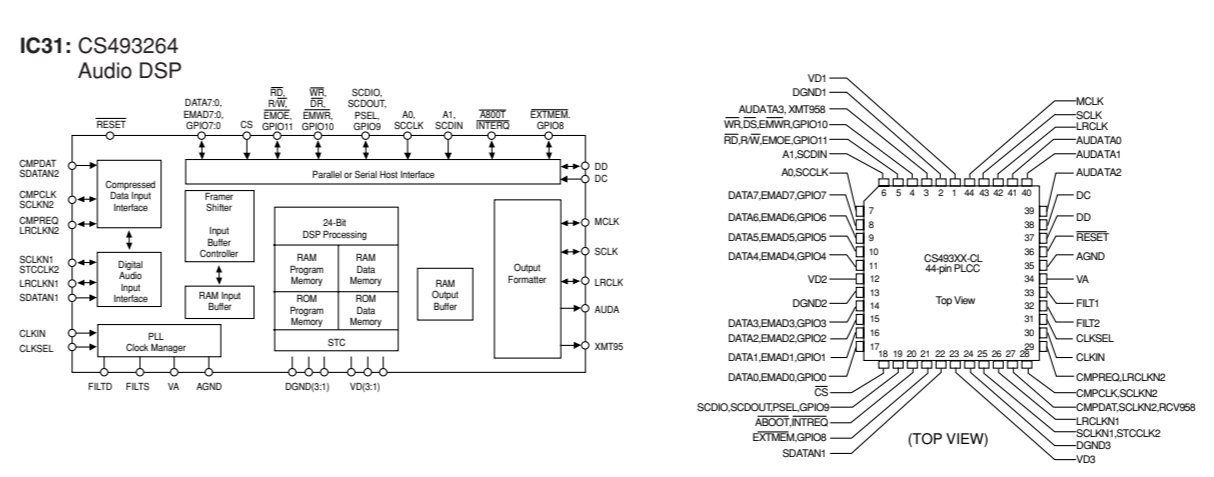
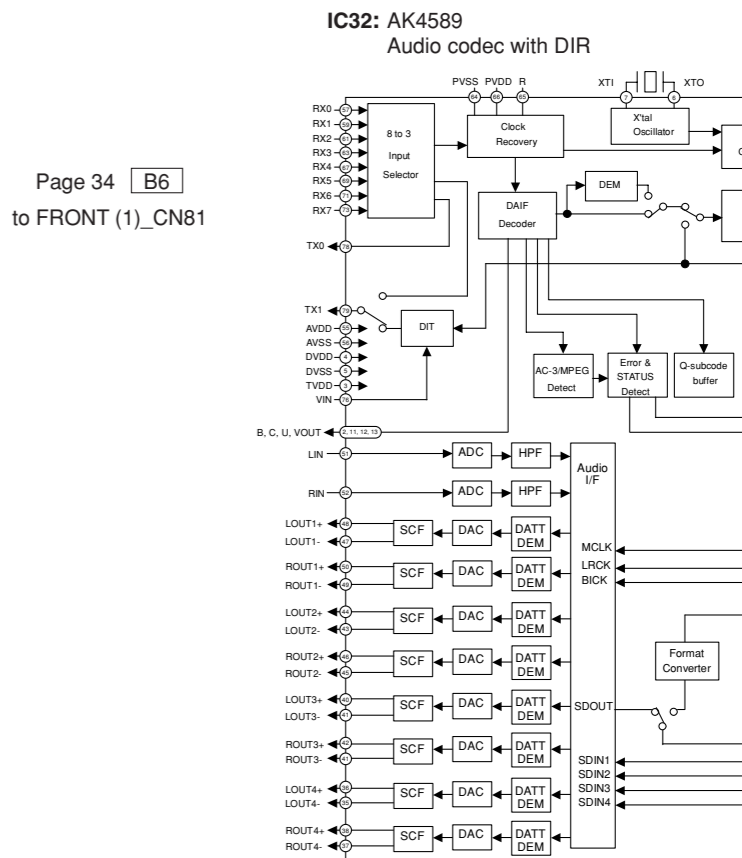
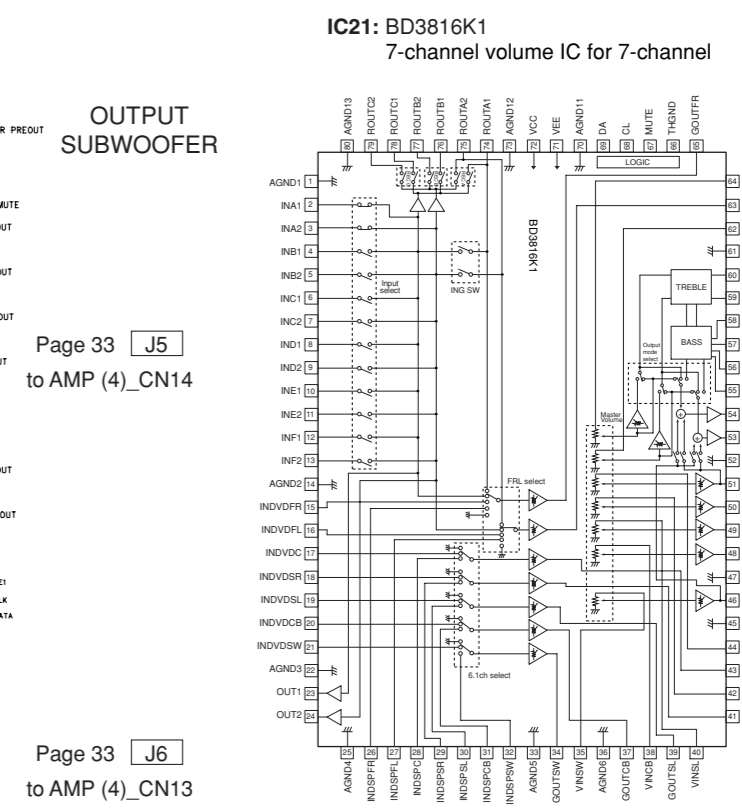
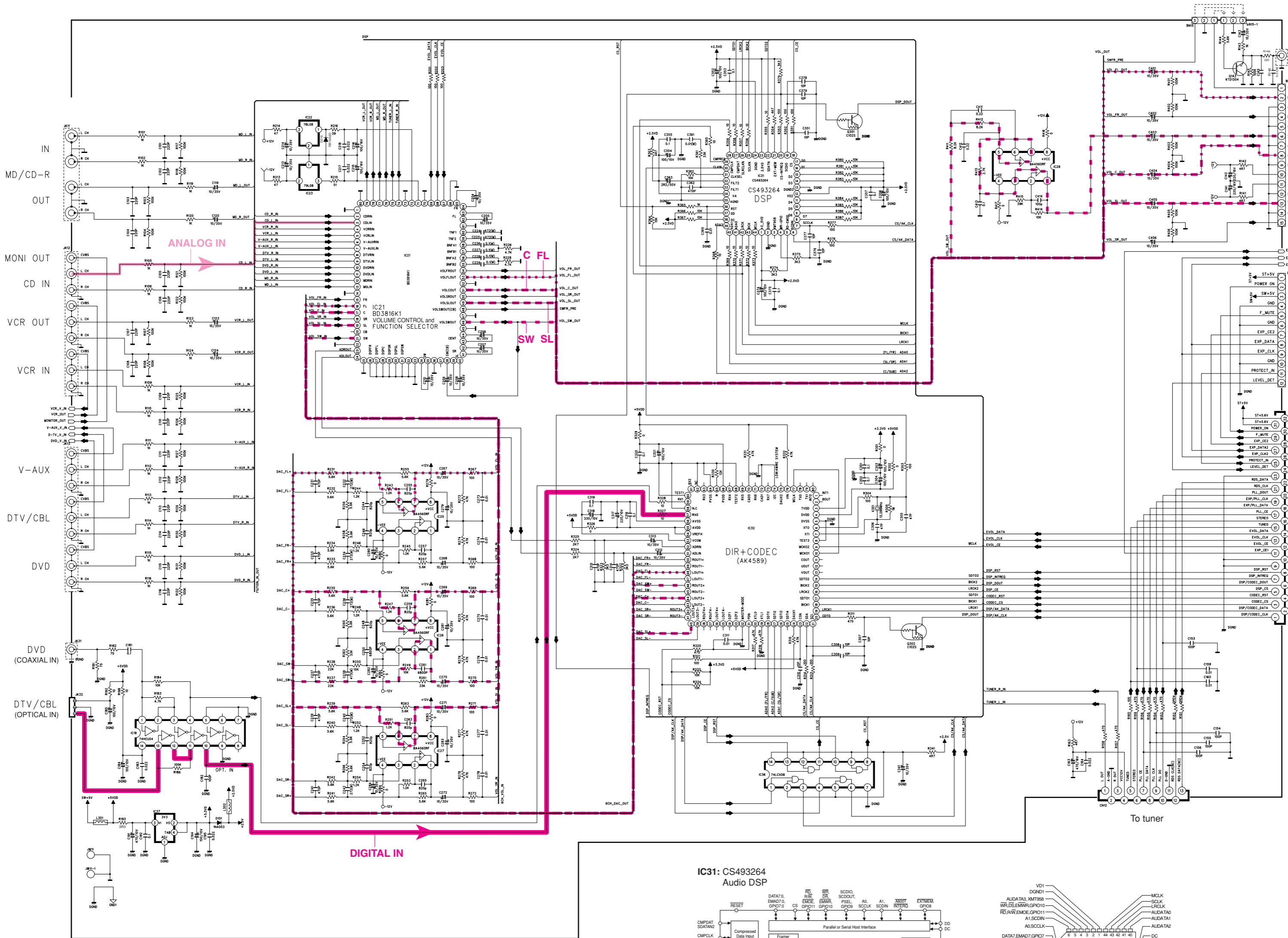

- ★ All voltages are measured with a 10M Ω/V DC electronic volt meter.
- ★ Components having special characteristics are marked with a triangle symbol and must be replaced with parts having specifications equal to those originally installed.
- ★ Schematic diagram is subject to change without notice.



INPUT 2/2

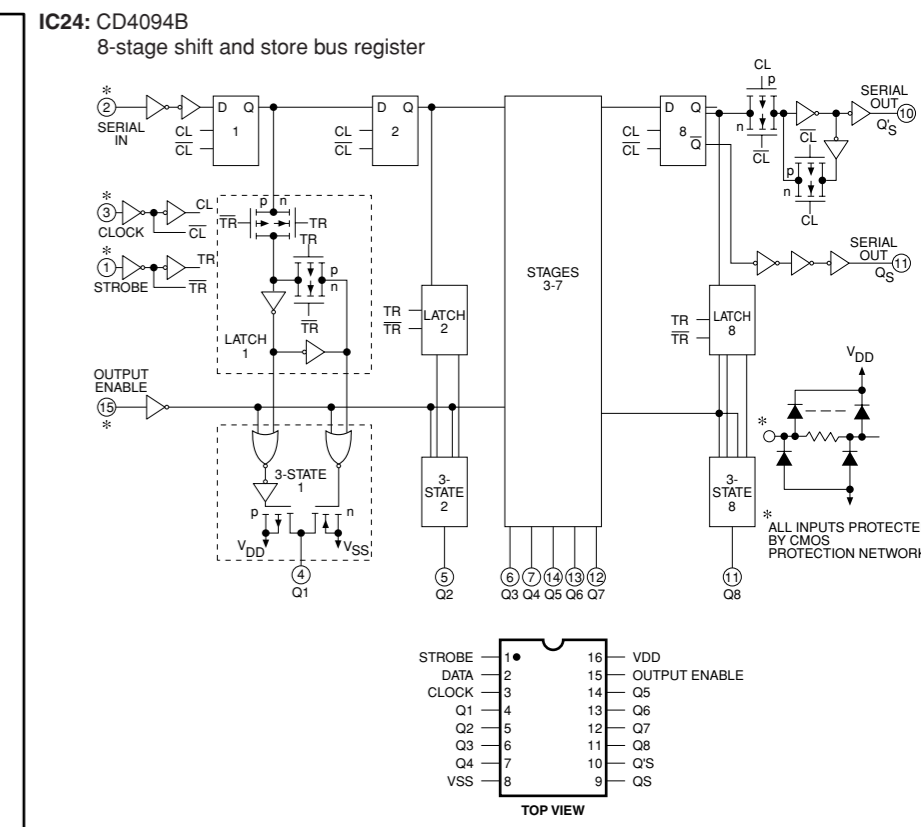
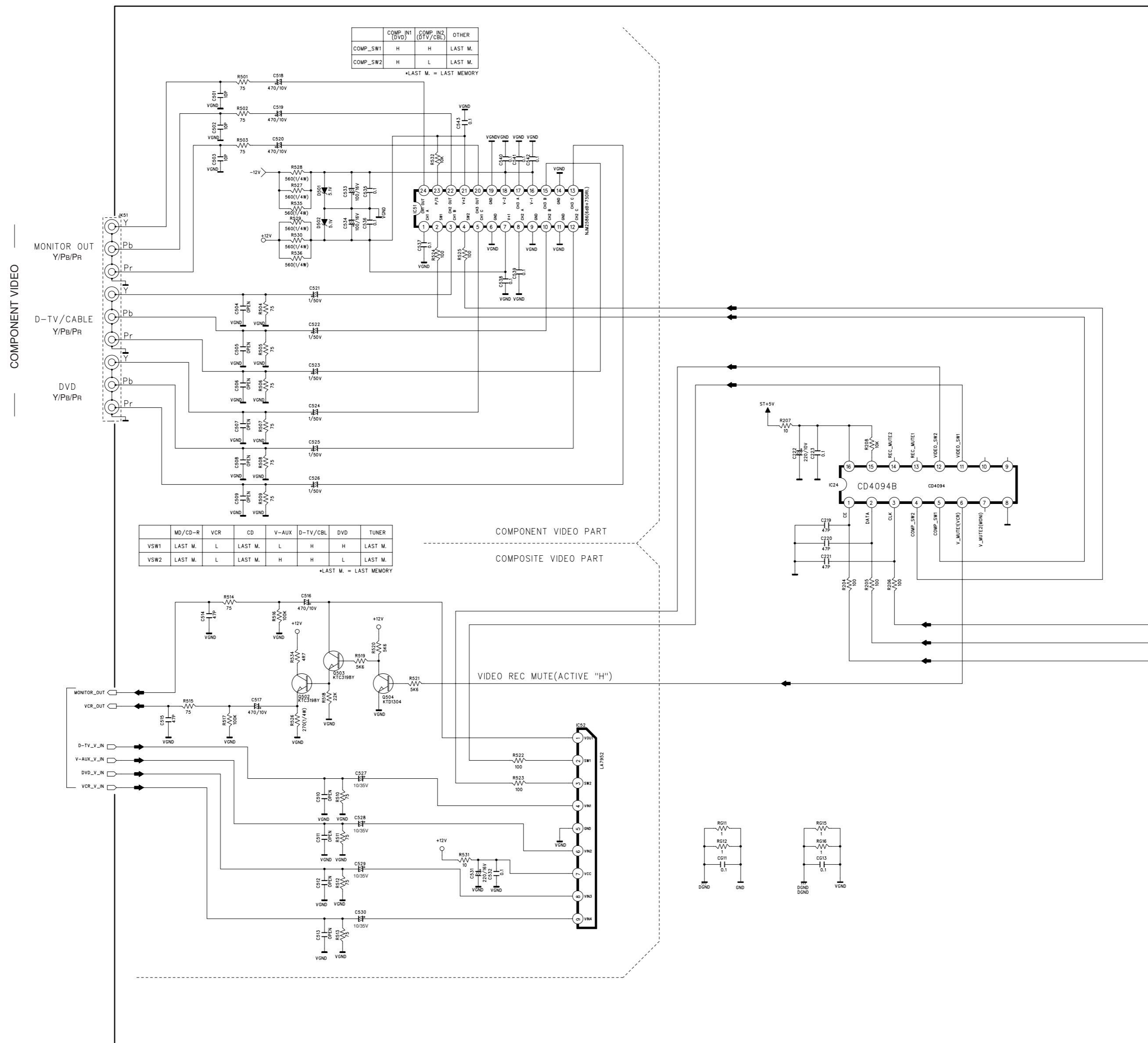

★ All voltages are measured with a 10M /V DC electronic volt meter.  
 ★ Components having special characteristics are marked  $\Delta$  and must be replaced with parts having specifications equal to those originally installed.  
 ★ Schematic diagram is subject to change without notice.

AMP

AMP (1)

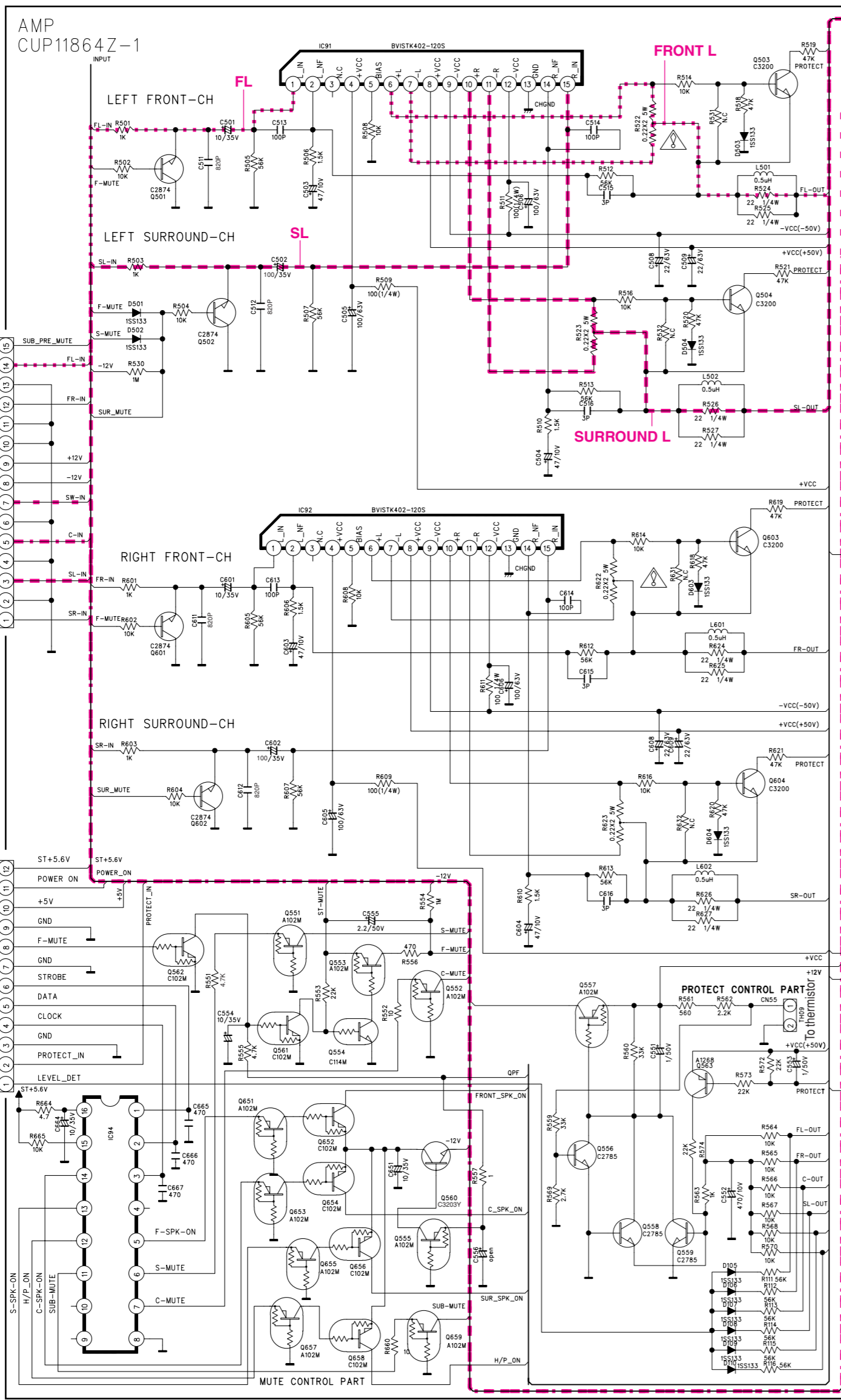

Page 33 [J6] to AMP (4)\_BN92

Page 33 [J6] to AMP (4)\_BN94

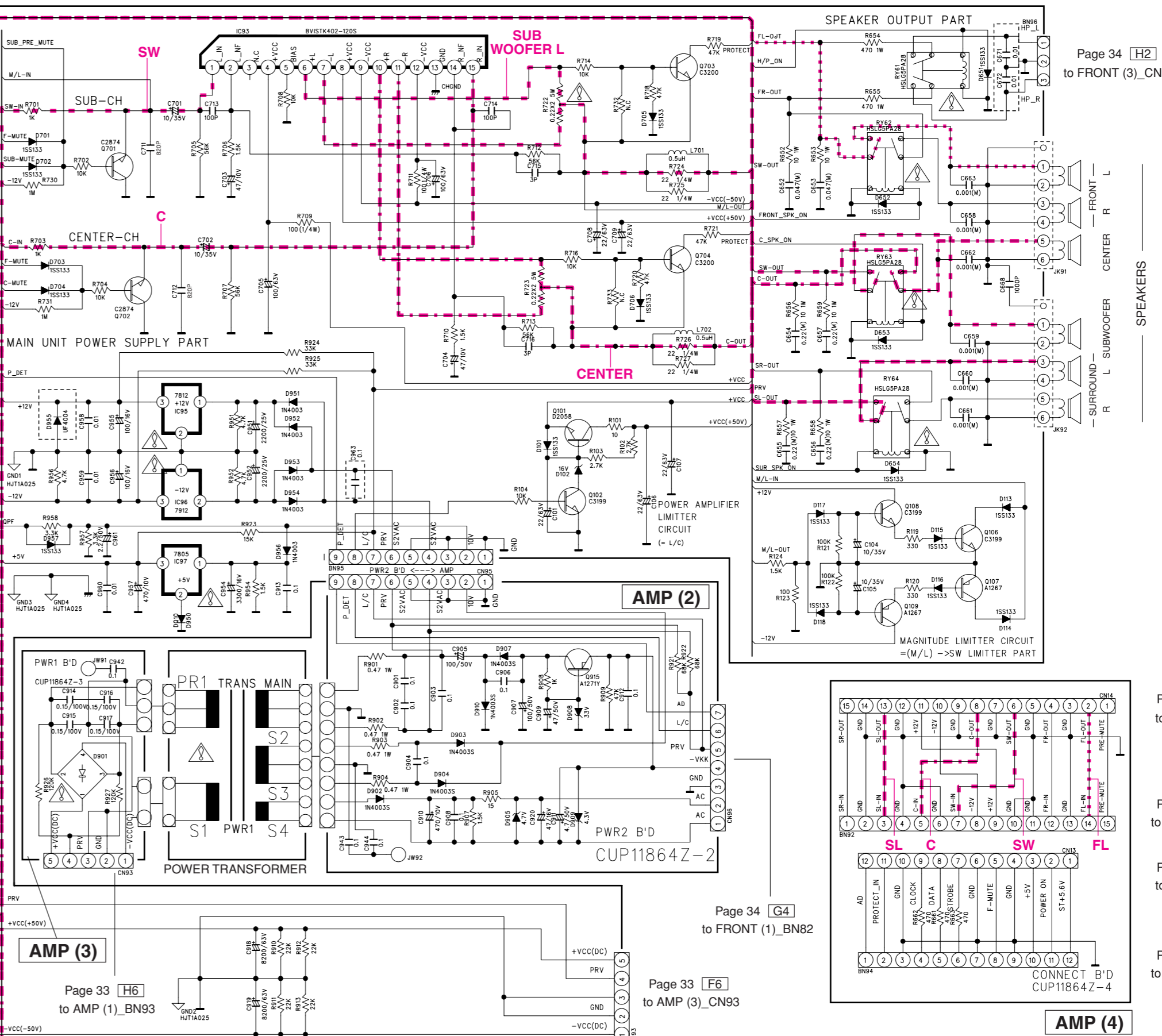

Page 34 [H2] to FRONT (3)\_CN96

Page 34 [G4] to FRONT (1)\_BN82

Page 33 [F6] to AMP (3)\_CN93

Page 31 [I3] to INPUT\_BN14

Page 33 [B6] to AMP (1)\_CN92

Page 31 [I4] to INPUT\_BN13

Page 33 [B4] to AMP (1)\_CN94

•IMPORTANT SAFETY NOTICE. COMPONENTS IDENTIFIED BY MARK HAVE SPECIAL CHARACTERISTICS. IMPORTANT FOR SAFETY. WHEN REPLACING ANY OF THESE COMPONENTS, USE ONLY MANUFACTURER'S SPECIFIED PARTS.

•THE UNIT OF RESISTANCE IS OHM.  
K=1000 OHM, M=1000 KOHM

•THE UNIT OF CAPACITANCE IS MICROFARAD (uF)  
1pF = 10<sup>-6</sup> uF

•THIS SCHEMATIC DIAGRAM MAY MODIFIED AT ANYTIME WITH THE IMPROVEMENT OF PERFORMANCE

To power transformer

To power cable

• All voltages are measured with a 10M Ω DC electronic volt meter.

• Components having special characteristics are marked and must be replaced with parts having specifications equal to those originally installed.

• Schematic diagram is subject to change without notice.

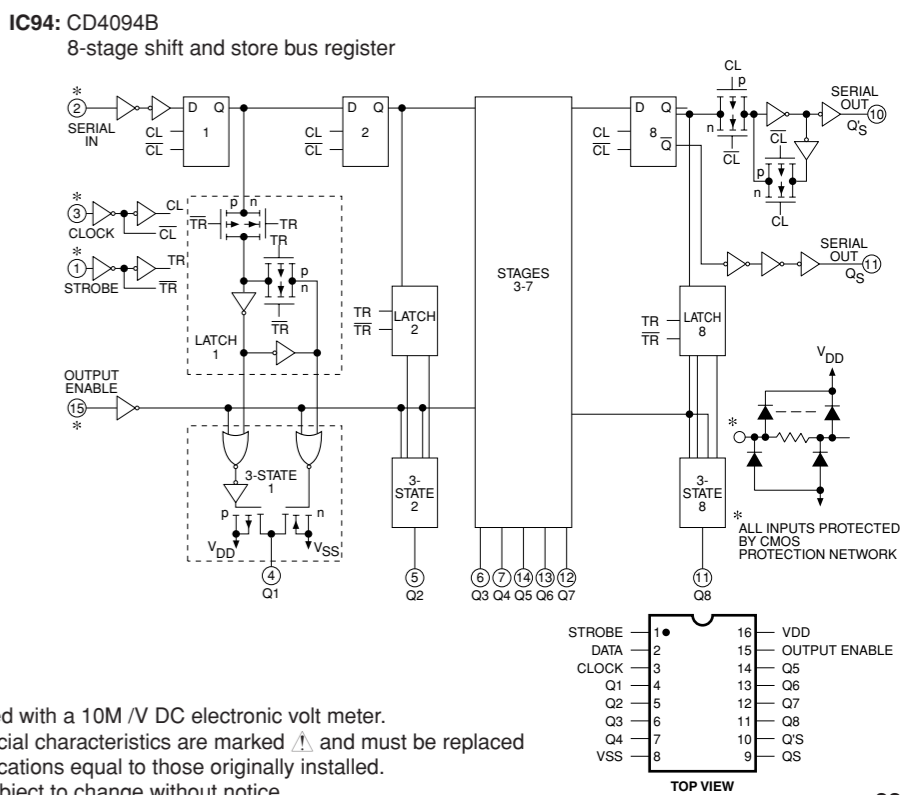

FRONT

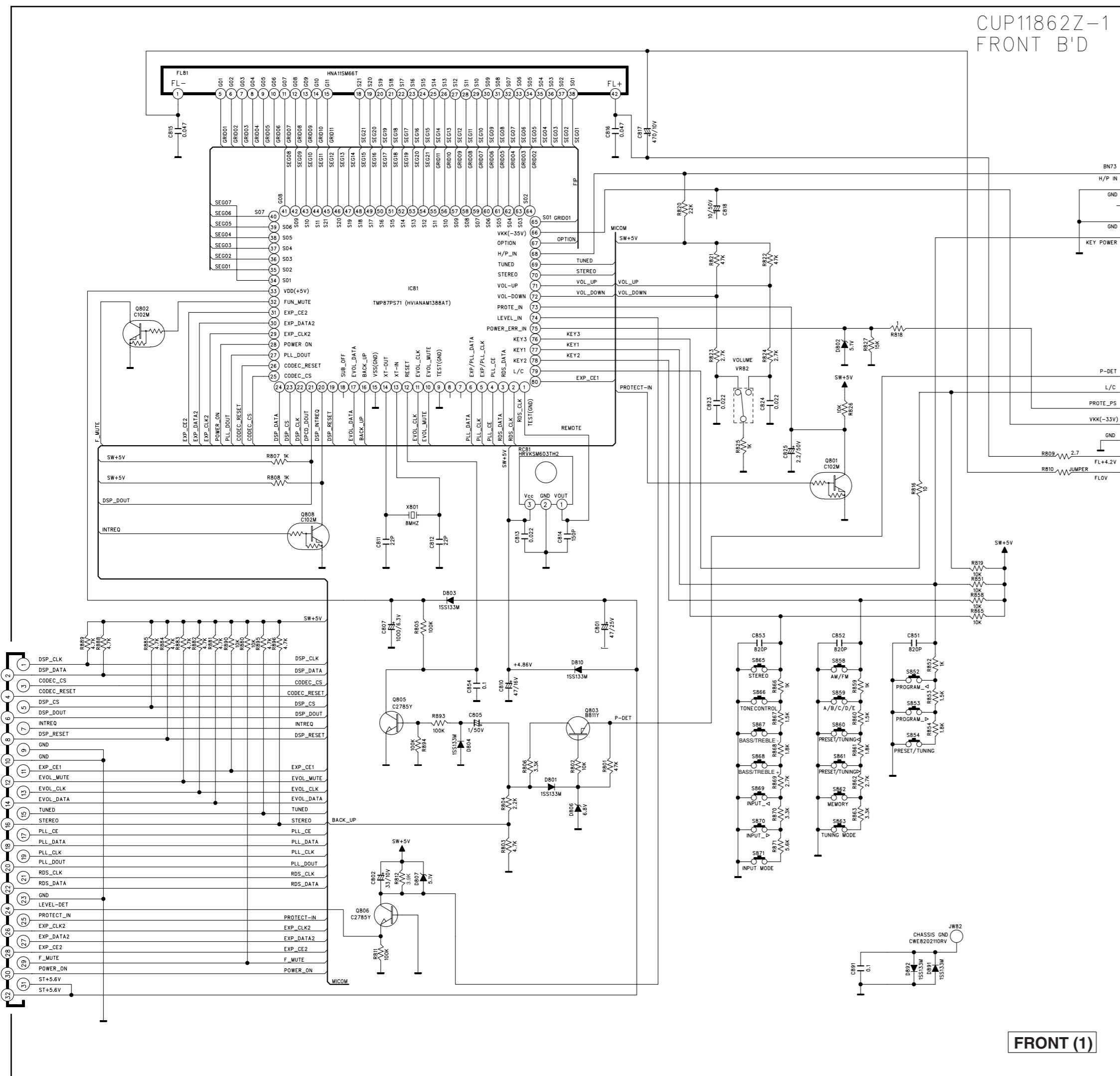

FRONT (1)

**\*\*IMPORTANT SAFETY NOTICE.**  
 COMPONENTS IDENTIFIED BY MARK HAVE SPECIAL CHARACTERISTICS.  
 IMPORTANT FOR SAFETY. WHEN REPLACING ANY OF THESE COMPONENTS,  
 USE ONLY MANUFACTURER'S SPECIFIED PARTS.

**\*\*THE UNIT OF RESISTANCE IS OHM.**  
 K=1000 OHM, M=1000 KOHM

**\*\*THE UNIT OF CAPACITANCE IS MICROFARAD (uF)**  
 1pF = 10<sup>-6</sup> uF

**\*\*THIS SCHEMATIC DIAGRAM MAY MODIFIED AT ANYTIME WITH THE IMPROVEMENT OF PERFORMANCE**

Page 33 [J2] to AMP (1)\_BN96

FRONT (3)

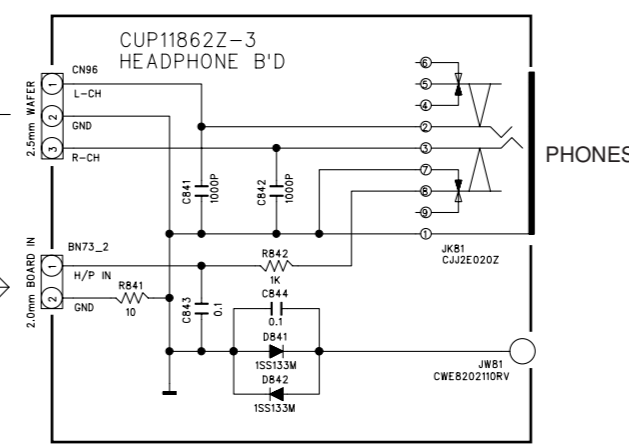

PHONES

FRONT (2)

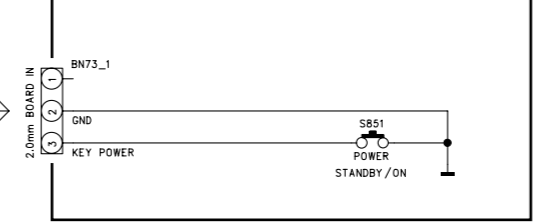

Page 33 [G4] to AMP (2)\_CN96

IC81 : TMP87PS71 Microprocessor

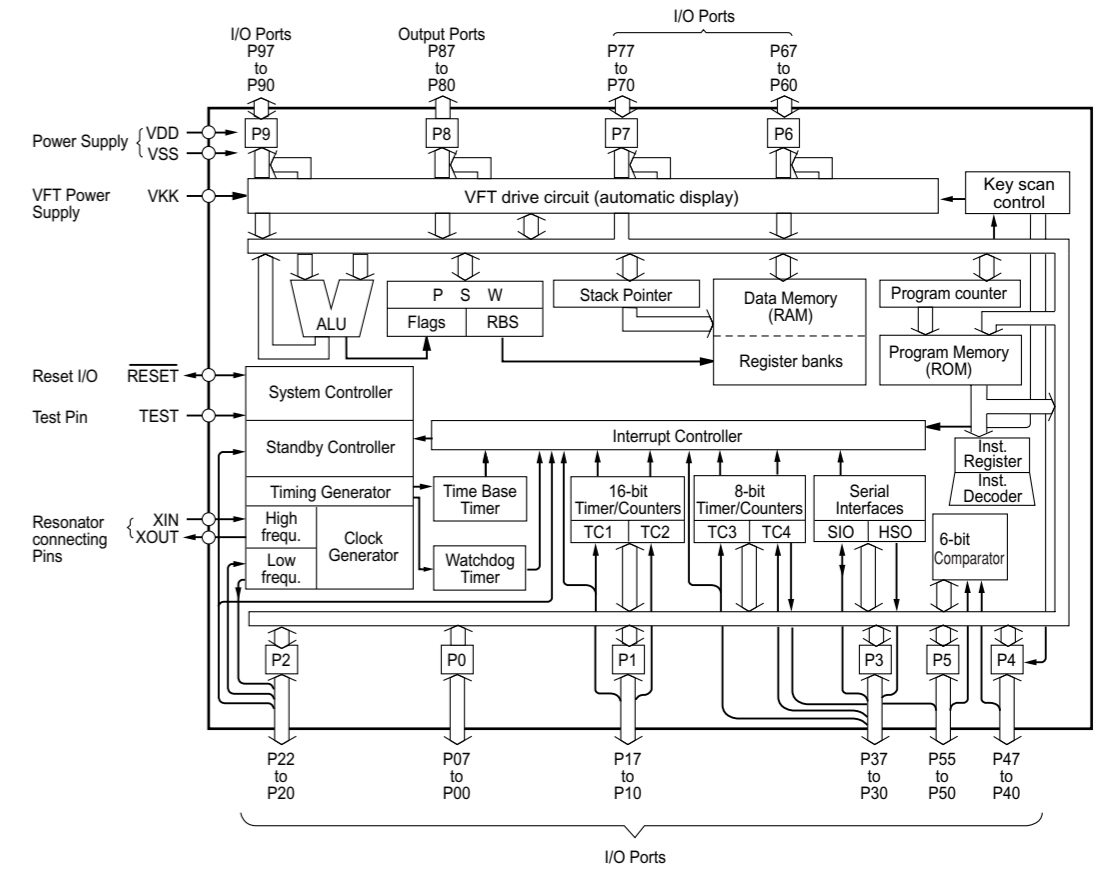

Page 31 [I5] to INPUT\_CN11

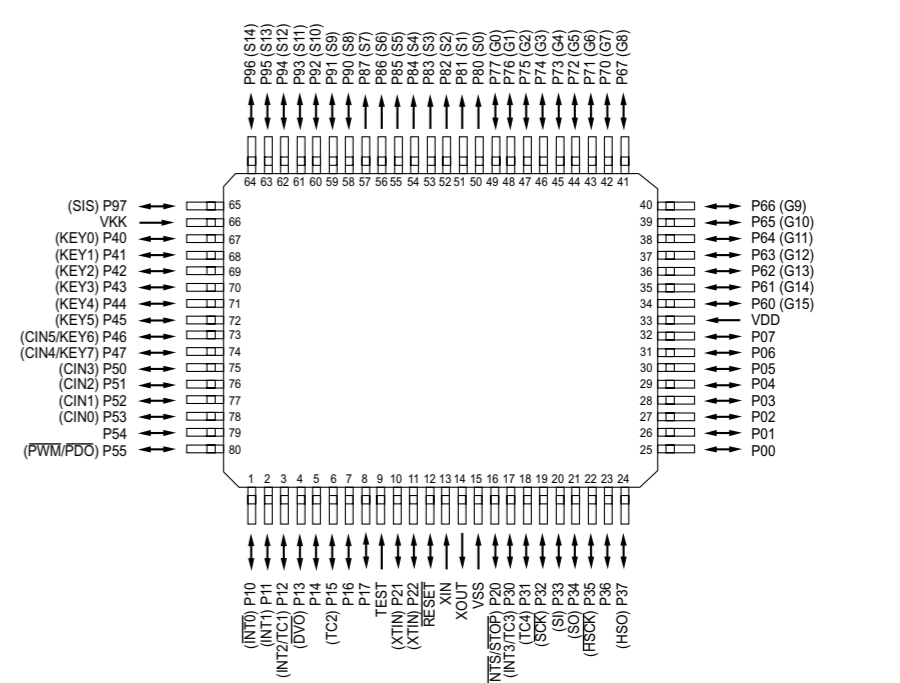

★ All voltages are measured with a 10M /V DC electronic volt meter.  
 ★ Components having special characteristics are marked and must be replaced with parts having specifications equal to those originally installed.  
 ★ Schematic diagram is subject to change without notice.



■ REPLACEMENT PARTS LIST

• ELECTRICAL COMPONENT PARTS

Note) When any part not included in the replacement parts list has failed, replace the P.C.B..

WARNING

Components having special characteristics are marked ⚠ and must be replaced with parts having specifications equal to those originally installed.

ABBREVIATIONS IN THIS LIST ARE AS FOLLOWS:

C.A.EL.CHP : CHIP ALUMI.ELECTROLYTIC CAP	L.EMIT : LIGHT EMITTING MODULE
C.CE : CERAMIC CAP	LED.DSPLY : LED DISPLAY
C.CE.ARRAY : CERAMIC CAP ARRAY	LED.INFRD : LED,INFRARED
C.CE.CHP : CHIP CERAMIC CAP	MODUL.RF : MODULATOR,RF
C.CE.ML : MULTILAYER CERAMIC CAP	PHOT.CPL : PHOTO COUPLER
C.CE.M.CHP : CHIP MULTILAYER CERAMIC CAP	PHOT.INTR : PHOTO INTERRUPTER
C.CE.SAFTY : RECOGNIZED CERAMIC CAP	PHOT.RFLCT : PHOTO REFLECTOR
C.CE.TUBLR : CERAMIC TUBULAR CAP	PIN.TEST : PIN,TEST POINT
C.CE.SMI : SEMI CONDUCTIVE CERAMIC CAP	PLST.RIVET : PLASTIC RIVET
C.EL : ELECTROLYTIC CAP	R.ARRAY : RESISTOR ARRAY
C.MICA : MICA CAP	R.CAR. : CARBON RESISTOR
C.ML.FLM : MULTILAYER FILM CAP	R.CAR.CHP : CHIP RESISTOR
C.MP : METALLIZED PAPER CAP	R.CAR.FP : FLAME PROOF CARBON RESISTOR
C.MYLAR : MYLAR FILM CAP	R.FUS : FUSABLE RESISTOR
C.MYLAR.ML : MULTILAYER MYLAR FILM CAP	R.MTL.CHP : CHIP METAL FILM RESISTOR
C.PAPER : PAPER CAPACITOR	R.MTL.FLM : METAL FILM RESISTOR
C.PLS : POLYSTYRENE FILM CAP	R.MTL.OXD : METAL OXIDE FILM RESISTOR
C.POL : POLYESTER FILM CAP	R.MTL.PLAT : METAL PLATE RESISTOR
C.POLY : POLYETHYLENE FILM CAP	RSNR.CE : CERAMIC RESONATOR
C.PP : POLYPROPYLENE FILM CAP	RSNR.CRYS : CRYSTAL RESONATOR
C.TNTL : TANTALUM CAP	R.TW.CEM : TWIN CEMENT FIXED RESISTOR
C.TNTL.CHP : CHIP TANTALUM CAP	R.CEMENT : CEMENT RESISTOR
C.TRIM : TRIMMER CAP	SCR.BND.HD : BIND HEAD B-TIGHT SCREW
CN : CONNECTOR	SCR.BW.HD : BW HEAD TAPPING SCREW
CN.BS.PIN : CONNECTOR,BASE PIN	SCR.CUP : CUP TIGHT SCREW
CN.CANNON : CONNECTOR,CANNON	SCR.TERM : SCREW TERMINAL
CN.DIN : CONNECTOR,DIN	SCR.TR : SCREW,TRANSISTOR
CN.FLAT : CONNECTOR,FLAT CABLE	SUPRT.PCB : SUPPORT,P.C.B.
CN.POST : CONNECTOR,BASE POST	SURG.PRTCT : SURGE PROTECTOR
COIL.MX.AM : COIL,AM MIX	SW.TACT : TACT SWITCH
COIL.AT.FM : COIL,FM ANTENNA	SW.LEAF : LEAF SWITCH
COIL.DT.FM : COIL,FM DETECT	SW.LEVER : LEVER SWITCH
COIL.MX.FM : COIL,FM MIX	SW.MICRO : MICRO SWITCH
COIL.OUTPT : OUTPUT COIL	SW.PUSH : PUSH SWITCH
DIOD.ARRAY : DIODE ARRAY	SW.RT.ENC : ROTARY ENCODER
DIODE.BRG : DIODE BRIDGE	SW.RT.MTR : ROTARY SWITCH WITH MOTOR
DIODE.CHP : CHIP DIODE	SW.RT : ROTARY SWITCH
DIODE.VAR : VARACTOR DIODE	SW.SLIDE : SLIDE SWITCH
DIOD.Z.CHP : CHIP ZENER DIODE	TERM.SP : SPEAKER TERMINAL
DIODE.ZENR : ZENER DIODE	TERM.WRAP : WRAPPING TERMINAL
DSCR.CE : CERAMIC DISCRIMINATOR	THRMST.CHP : CHIP THERMISTOR
FER.BEAD : FERRITE BEADS	TR.CHP : CHIP TRANSISTOR
FER.CORE : FERRITE CORE	TR.DGT : DIGITAL TRANSISTOR
FET.CHP : CHIP FET	TR.DGT.CHP : CHIP DIGITAL TRANSISTOR
FL.DSPLY : FLUORESCENT DISPLAY	TRANS : TRANSFORMER
FLTR.CE : CERAMIC FILTER	TRANS.PULS : PULSE TRANSFORMER
FLTR.COMB : COMB FILTER MODULE	TRANS.PWR : POWER TRANSFORMER ASS'Y
FLTR.LC.RF : LC FILTER,EMI	TUNER.AM : TUNER PACK,AM
GND.MTL : GROUND PLATE	TUNER.FM : TUNER PACK,FM
GND.TERM : GROUND TERMINAL	TUNER.PK : FRONT-ENDTUNER PACK
HOLDER.FUS : FUSE HOLDER	VR : ROTARY POTENTIOMETER
IC.PRTCT : IC PROTECTOR	VR.MTR : POTENTIOMETER WITH MOTOR
JUMPER.CN : JUMPER CONNECTOR	VR.SW : POTENTIOMETER WITH ROTARY SW
JUMPER.TST : JUMPER,TEST POINT	VR.SLIDE : SLIDE POTENTIOMETER
L.DTCT : LIGHT DETECTING MODULE	VR.TRIM : TRIMMER POTENTIOMETER

P.C.B. INPUT

Ref. No.	Part No.	Description	Markets
*	AAX76710	P. C. B.	INPUT
*	IC18	AAX77300 IC	74HCU04
*	IC21	AAX77130 IC	BD3816K1
*	IC22	AAX77330 IC	KA78L08
*	IC23	AAX77340 IC	KA79L08
*	IC24	AAX77150 IC	CD4094B
*	IC25-28	AAX77190 IC	BA4560RF
*	IC36	AAX77310 IC	74LCX08
*	IC37	AAX77380 IC	LM1117S-3V3
*	IC51	AAX77160 IC	NUM2586
*	JK11	AAX77250 JACK. PIN	4P
*	JK12-13	AAX77220 JACK. PIN	9P
*	JK14	AAX77230 JACK. PIN	1P
*	JK31	AAX77240 JACK. PIN	1P
*	JK32	AAX77320 CN. PHOTO	1P
*	JK51	AAX77210 JACK. PIN	9P

\* New Parts

P.C.B. AMP and P.C.B. FRONT

Ref. No.	Part No.	Description	Markets
*	AAX76700	P. C. B.	AMP
*	F903	AAX77120 FUSE	6.3A 250V
*	IC91-93	AAX77180 IC. AMP	STK402-120S
*	IC94	AAX77140 IC	CD4094BE
*	⚠ IC95	AAX77360 IC	K1A7812AP1
*	⚠ IC96	AAX77370 IC	K1A7912P1
*	IC98	AAX77350 IC	K1A7805AP1
*	JK91-92	AAX77200 TERM. SP	6P PUSH TYPE
*	⚠ RY61-64	AAX77280 RELAY	G5PA28
*	⚠ RY91	AAX77270 RELAY	G5PA1ME
*	⚠ T901	AAX77390 TRANS. PWR	
*	AAX76720	P. C. B.	FRONT
*	IC81	AAX77170 IC. CPU	TMP87PS71 (MASK ROM)
*	JK81	AAX77260 JACK. PHONE	
*	S851-871	AAX74630 SW. TACT	SKHV10910G
*	VR82	AAX77290 SW. RT. ENC	VOLUME

\* New Parts

• OVERALL ASS'Y

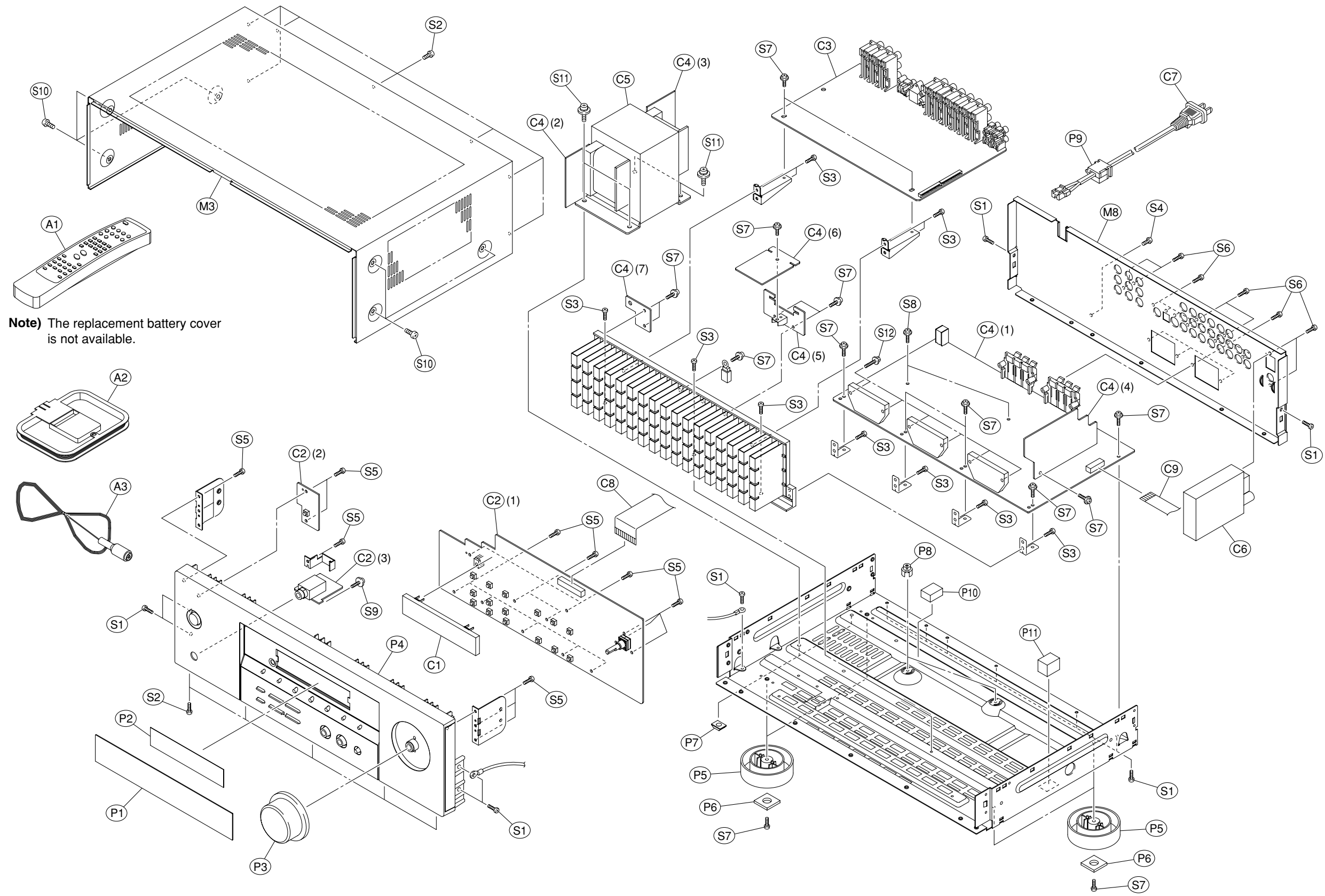

**Note)** The replacement battery cover is not available.



• OVERALL ASS'Y

Ref. No.	Part No.	Description	Remarks	Markets
* P1	AAX76670	FIP WINDOW	CGU1A387Z	
* P2	AAX76810	FILTER	CMZ1A108	
* P3	AAX76820	VOLUME KNOB	CBN1A207M7G5	
* P4	AAX76690	FRONT PANEL ASS'Y	CGW1A416ZA	
* P5	AAX76850	FOOT	CKL1A089M7G5	
* P6	AAX76760	CUSHION FOOT	CHG1A329	
P7	AAX73640	RUBBER	CHG1A113	
P8	AAX73910	P.C.B. SUPPORT	CHE170	
P9	AAX73380	CORD STOPPER	KHR1A028	
* P10	AAX76740	CUSHION	15x20x9 CHG1A104	
* P11	AAX76750	CUSHION	CHG1A160	
* C1	AAX76870	VFD	HFLHNA11SM66T	
* C2	AAX76720	P.C.B. ASS'Y	FRONT COP11862B	
* C3	AAX76710	P.C.B. ASS'Y	INPUT COP11863B	
* C4	AAX76700	P.C.B. ASS'Y	AMP COP11864B	
* ⚠ C5	AAX76860	POWER TRANSFORMER	CLT5U023ZU	
* C6	AAX76650	TUNER MODULE	CNVMP001MA0E17	
* ⚠ C7	AAX74370	POWER CABLE	2m CJA523FBYA	
* C8	AAX77740	FLEXIBLE FLAT CABLE	32P 150mm P=1.25 CWC4F2A32B150B	
* C9	AAX74730	FLEXIBLE FLAT CABLE	13P 100mm P=1.25 CWC1B2A13B100B	
* M3	AAX76790	CABINET TOP	CKC1A169G33	
* M8	AAX76830	PANEL REAR	CKF1A305Z	
S1	AAX73490	BIND HEAD B-TIGHT SCREW	3x6 MFZN2W3 CTB3+6J	
S2	AAX73500	BIND HEAD B-TIGHT SCREW	3x8 MFC2 CTB3+8JFC	
S3	AAX74120	BIND HEAD B-TIGHT SCREW	3x8 MFZN2W3 CTB3+8J	
S4	AAX73510	BIND HEAD B-TIGHT SCREW	3x8 MFZN2BL CTB3+8JFZ	
S5	AAX73540	BIND HEAD P-TIGHT SCREW	3x10 MFZN2Y CTB3+10G	
* S6	AAX76800	BIND HEAD P-TIGHT SCREW	3x10 MFZN2BL CTBD3+10GFZ	
S7	AAX73340	PW HEAD B-TIGHT SCREW	3x8 MFZN2Y CTW3+8J	
S8	AAX73320	PW HEAD B-TIGHT SCREW	3x12 MFZN2Y CTW3+12J	
* S9	AAX76730	PW HEAD P-TIGHT SCREW	3x10 MFZN2Y CTWS3+10G	
S10	AAX73580	BIND HEAD SCREW	4x6 MFC2 CTB4+6FFC	
* S11	AAX76780	SEMS BIND HEAD S-TIGHT SCREW	4x10 MFZN2Y CHD1A023	
* S12	AAX76770	SCREW IC	3x18 MFZN2BL CHD5A012	
		ACCESSORIES		
* A1	AAX76840	REMOTE CONTROL	CARTHTR5920	
* A2	AAX76660	AM LOOP ANTENNA	1.0m 1pc CSA1A028Z	
* A3	AAX76680	INDOOR FM ANTENNA BATTERY	1.6m 1pc R03 2pcs CSA1A019Z	

\* New Parts

# REMOTE CONTROL

## SCHEMATIC DIAGRAM

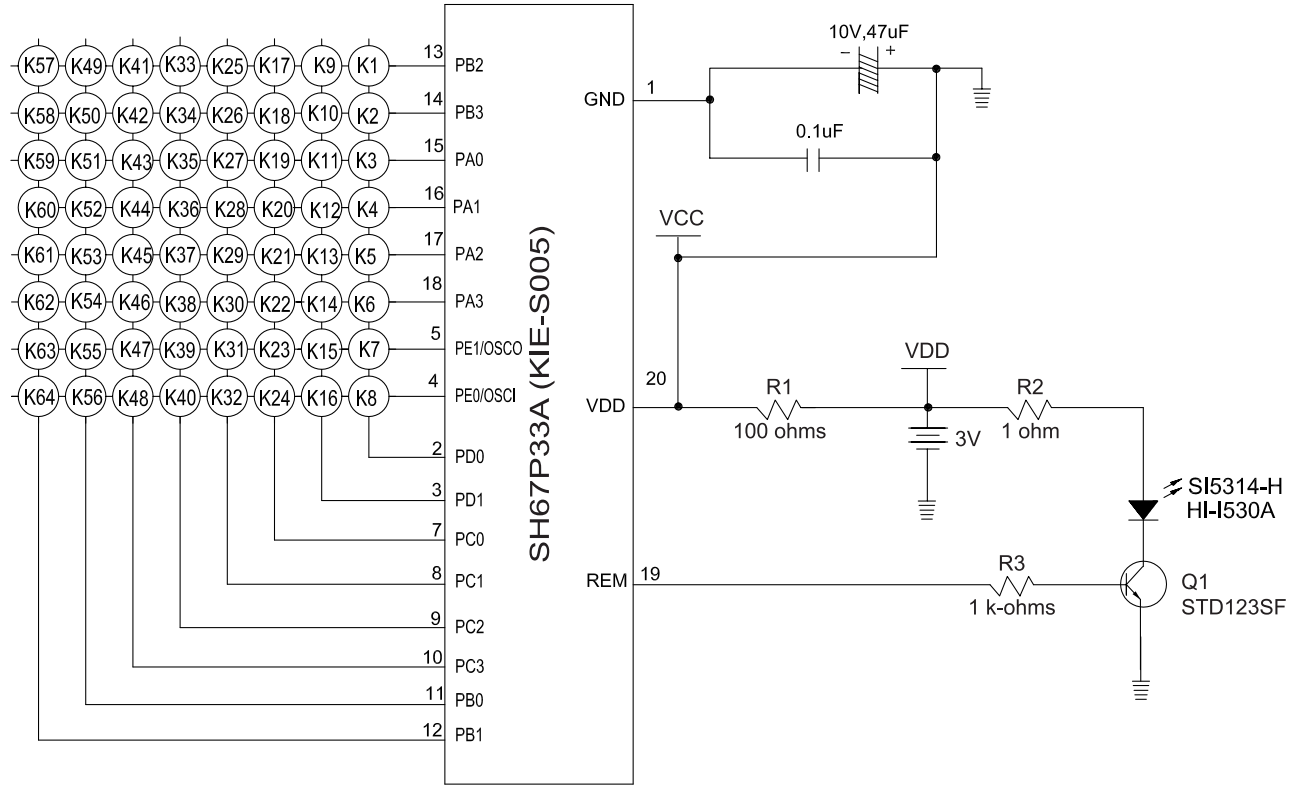

## PANEL

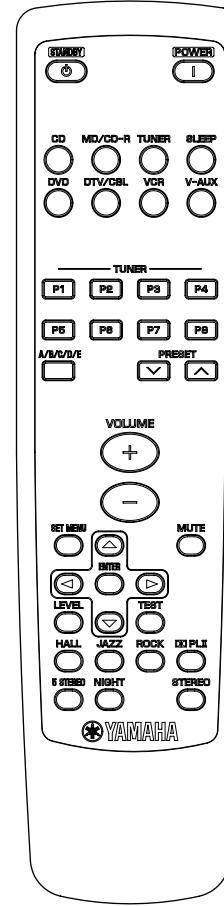

## KEY LAYOUT

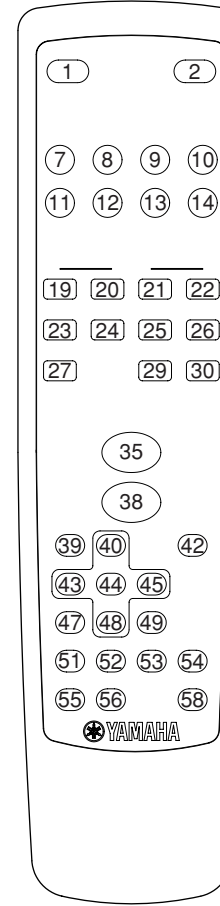

## KEY CODE

No.	Label	Key	Code	No.	Label	Key	Code	No.	Label	Key	Code
1	STANDBY	O	7A-1E	21	P3	O	7A-E7	41	-	-	-
2	POWER on	O	7A-1D	22	P4	O	7A-E8	42	MUTE	O	7A-1C
3	-	-	-	23	P5	O	7A-E9	43	LEFT	O	7A-53
4	-	-	-	24	P6	O	7A-EA	44	ENTER	O	7A-DE
5	-	-	-	25	P7	O	7A-EB	45	RIGHT	O	7A-52
6	-	-	-	26	P8	O	7A-EC	46	-	-	-
7	CD	O	7A-15	27	A/B/C/D/E	O	7A-12	47	LEVEL	O	7A-86
8	MD/CD-R	O	7A-C9	28	-	-	-	48	DOWN	O	7A-99
9	TUNER	O	7A-16	29	PRESET-	O	7A-11	49	TEST	O	7A-85
10	SLEEP	O	7A-57	30	PRESET+	O	7A-10	50	-	-	-
11	DVD	O	7A-C1	31	-	O	7A-1A	51	HALL	O	7A-88
12	DTV/CBL	O	7A-54	32	-	-	-	52	JAZZ	O	7A-89
13	VCR	O	7A-0F	33	-	-	-	53	ROCK	O	7A-8A
14	V-AUX	O	7A-55	34	-	-	-	54	Dolby PLII	O	7A-8B
15	-	-	-	35	VOL +	-	-	55	5 STEREO	O	7A-8C
16	-	-	-	36	-	-	-	56	NIGHT	O	7A-95
17	-	-	-	37	-	-	-	57	-	-	-
18	-	-	-	38	VOL -	O	7A-1B	58	STEREO	O	7A-56
19	P1	O	7A-E5	39	SET MENU	O	7A-9C				
20	P2	O	7A-E6	40	UP	O	7A-98				