

AV RECEIVER/AV AMPLIFIER

RX-V559/HTR-5950/DSP-AX559

SERVICE MANUAL

IMPORTANT NOTICE

This manual has been provided for the use of authorized YAMAHA Retailers and their service personnel. It has been assumed that basic service procedures inherent to the industry, and more specifically YAMAHA Products, are already known and understood by the users, and have therefore not been restated.

WARNING: Failure to follow appropriate service and safety procedures when servicing this product may result in personal injury, destruction of expensive components, and failure of the product to perform as specified. For these reasons, we advise all YAMAHA product owners that any service required should be performed by an authorized YAMAHA Retailer or the appointed service representative.

IMPORTANT: The presentation or sale of this manual to any individual or firm does not constitute authorization, certification or recognition of any applicable technical capabilities, or establish a principle-agent relationship of any form.

The data provided is believed to be accurate and applicable to the unit(s) indicated on the cover. The research, engineering, and service departments of YAMAHA are continually striving to improve YAMAHA products. Modifications are, therefore, inevitable and specifications are subject to change without notice or obligation to retrofit. Should any discrepancy appear to exist, please contact the distributor's Service Division.

WARNING: Static discharges can destroy expensive components. Discharge any static electricity your body may have accumulated by grounding yourself to the ground buss in the unit (heavy gauge black wires connect to this buss).

IMPORTANT: Turn the unit OFF during disassembly and part replacement. Recheck all work before you apply power to the unit.

CONTENTS

TO SERVICE PERSONNEL	2-3	DISPLAY DATA	44-47
FRONT PANELS	3-4	IC DATA	48-57
REAR PANELS	5-8	PIN CONNECTION DIAGRAM	58-59
REMOTE CONTROL PANELS	9	BLOCK DIAGRAMS	61-63
SPECIFICATIONS / 参考仕様	10-12	PRINTED CIRCUIT BOARDS	64-80
INTERNAL VIEW	13	SCHEMATIC DIAGRAMS	81-88
DISASSEMBLY PROCEDURES / 分解手順	14-17	REPLACEMENT PARTS LIST	89-114
SELF DIAGNOSIS FUNCTION (DIAG) / 自己診断機能(ダイアグ)	18-42	REMOTE CONTROL	115
AMP ADJUSTMENT / アンブ部調整	43	ADVANCED SETUP	116



このサービスマニュアルは、エコマーク認定の再生紙を使用しています。
This Service Manual uses recycled paper.

100997

© 2006 YAMAHA CORPORATION. All rights reserved.
This manual is copyrighted by YAMAHA and may not be copied or
redistributed either in print or electronically without permission.



YAMAHA

YAMAHA CORPORATION
P.O.Box 1, Hamamatsu, Japan

06.02

RX-V559/HTR-5950/
DSP-AX559

■ TO SERVICE PERSONNEL

1. Critical Components Information
Components having special characteristics are marked ⚠ and must be replaced with parts having specifications equal to those originally installed.
 2. Leakage Current Measurement (For 120V Models Only)
When service has been completed, it is imperative to verify that all exposed conductive surfaces are properly insulated from supply circuits.
- Meter impedance should be equivalent to 1500 ohms shunted by 0.15μF.

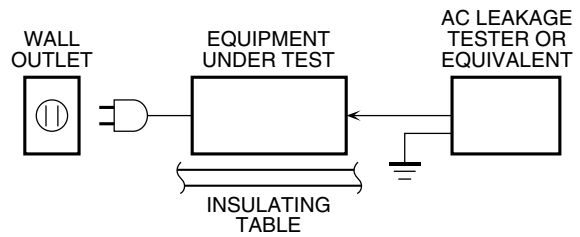

- Leakage current must not exceed 0.5mA.
- Be sure to test for leakage with the AC plug in both polarities.



“CAUTION”

“F3000, 3001: FOR CONTINUED PROTECTION AGAINST RISK OF FIRE, REPLACE ONLY WITH SAME TYPE 8A, 125V FUSE.”

CAUTION

F3000, 3001: REPLACE WITH SAME TYPE 8A, 125V FUSE.

ATTENTION

F3000, 3001: UTILISER UN FUSIBLE DE RECHANGE DE MEME TYPE DE 8A, 125V.

WARNING: CHEMICAL CONTENT NOTICE!

The solder used in the production of this product contains LEAD. In addition, other electrical/electronic and/or plastic (where applicable) components may also contain traces of chemicals found by the California Health and Welfare Agency (and possibly other entities) to cause cancer and/or birth defects or other reproductive harm.

DO NOT PLACE SOLDER, ELECTRICAL/ELECTRONIC OR PLASTIC COMPONENTS IN YOUR MOUTH FOR ANY REASON WHATSOEVER!

Avoid prolonged, unprotected contact between solder and your skin! When soldering, do not inhale solder fumes or expose eyes to solder/flux vapor!

If you come in contact with solder or components located inside the enclosure of this product, wash your hands before handling food.

About Lead Free Solder / 無鉛ハンダについて

The P.C.B.s installed in this unit are soldered using the following solder.

本機に搭載されている基板のハンダ付けに使用されているハンダは下記の通りです。

	SIDE A / A面	SIDE B / B面
DSP P.C.B.	lead free solder / 無鉛ハンダ	lead free solder / 無鉛ハンダ
FUNCTION P.C.B.	—	lead free solder / 無鉛ハンダ
OPERATION P.C.B.	—	lead free solder / 無鉛ハンダ
MAIN P.C.B.	—	lead free solder / 無鉛ハンダ
VIDEO P.C.B.	lead free solder / 無鉛ハンダ	lead free solder / 無鉛ハンダ

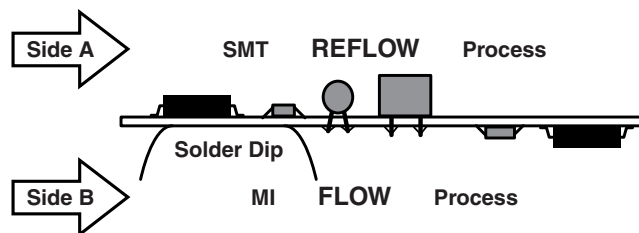

Among some types of lead free solder currently available, it is recommended to use one of the following types for the repair work.

- Sn + Ag + Cu (tin + silver + copper)
- Sn + Cu (tin + copper)
- Sn + Zn + Bi (tin + zinc + bismuth)

Caution:

1. As the melting point temperature of the lead free solder is about 30°C to 40°C (50°F to 70°F) higher than that of the lead solder, be sure to use a soldering iron suitable to each solder.
2. If lead solder must be used, be sure to remove lead free solder from each terminal section of the parts to be replaced and from the area around it completely before soldering, or make sure that the lead free solder and lead solder melt together fully.

無鉛ハンダにはいくつかの種類がありますが、修理時には下記のような無鉛ハンダの使用を推奨します。

- ・ Sn+Ag+Cu(錫+銀+銅)
- ・ Sn+Cu(錫+銅)
- ・ Sn+Zn+Bi(錫+亜鉛+ビスマス)

注意：

1. 無鉛ハンダの融点温度は通常の鉛入りハンダに比べ30～40℃程度高くなっていますので、それぞれのハンダに合ったハンダごてをご使用ください。
2. 鉛入りハンダを使わざるを得ない場合は、あらかじめ交換する部品端子部やその周辺部の無鉛ハンダをすべて取り除くか、あるいは無鉛ハンダと鉛入りハンダが十分に溶けた状態となるようにハンダ付けしてください。

■ FRONT PANELS

RX-V559 (U, C models)

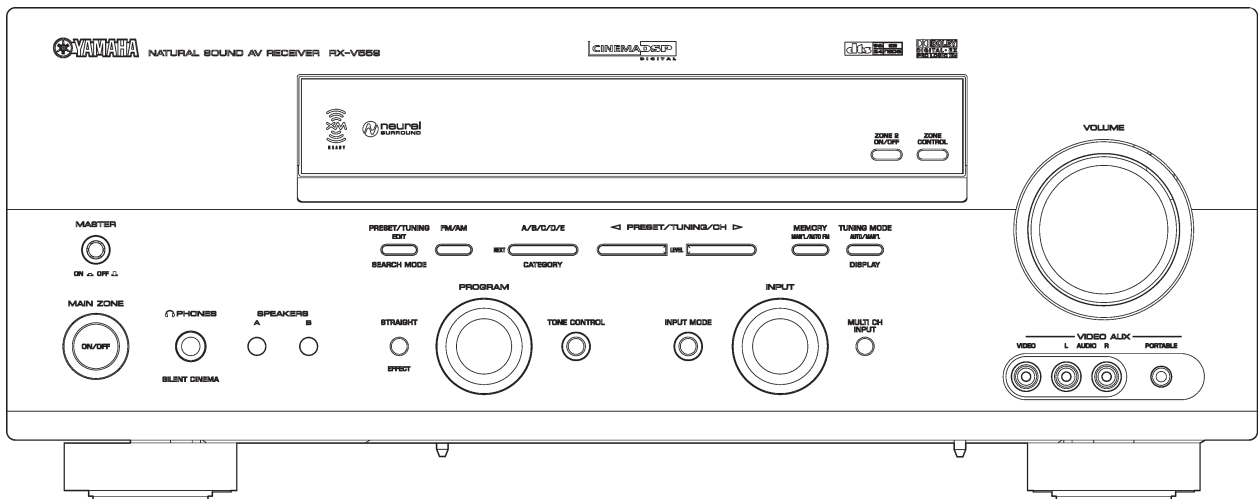

RX-V559 (R, T, K, A, G, E, L models)

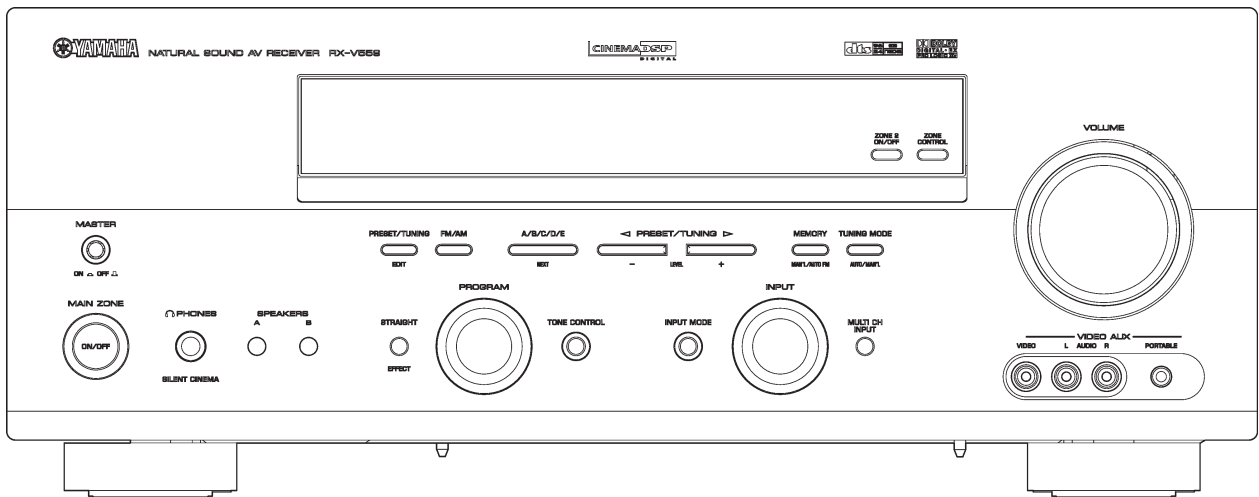

RX-V559/HTR-5950/
DSP-AX559

HTR-5950 (U, C models)

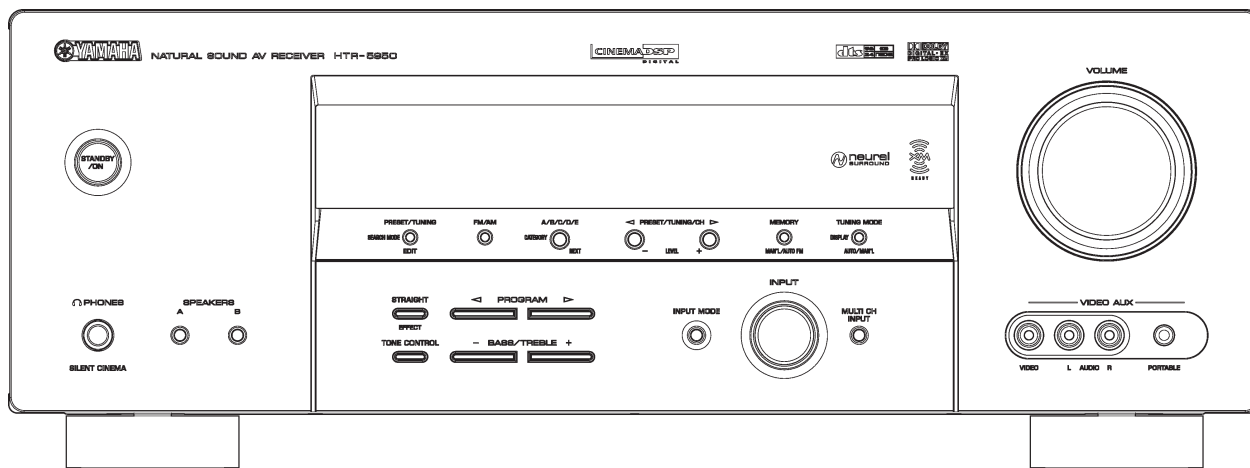

HTR-5950 (T, A models)

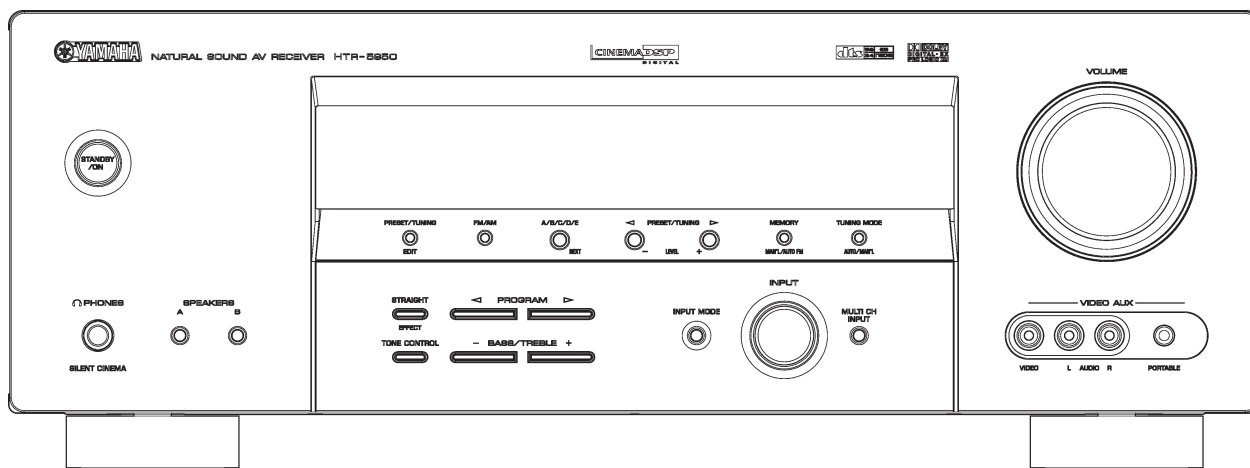

DSP-AX559 (J model)

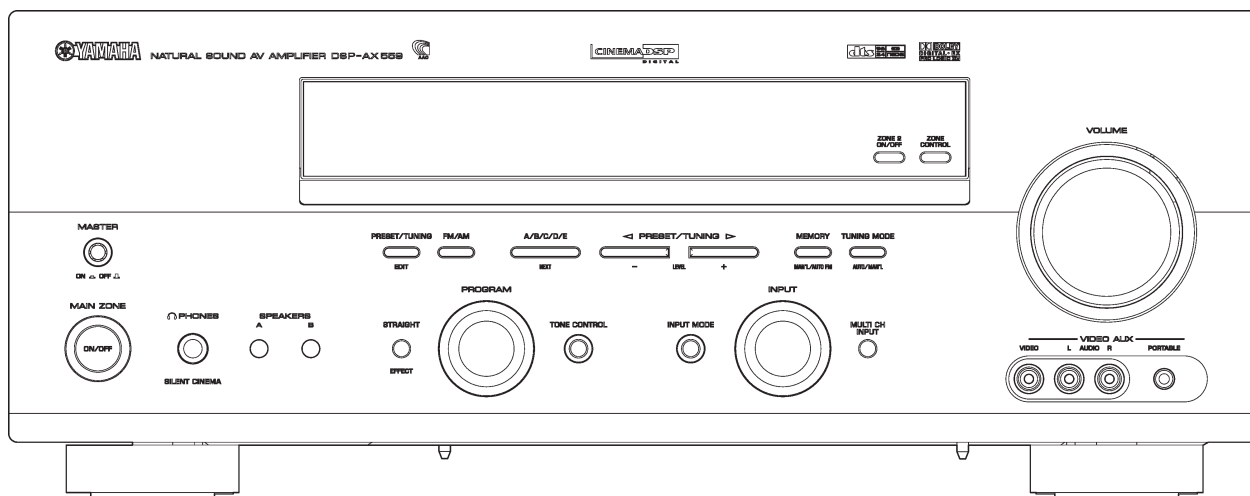

RX-V559/HTR-5950/
DSP-AX559

REAR PANELS

RX-V559 (U, C models)

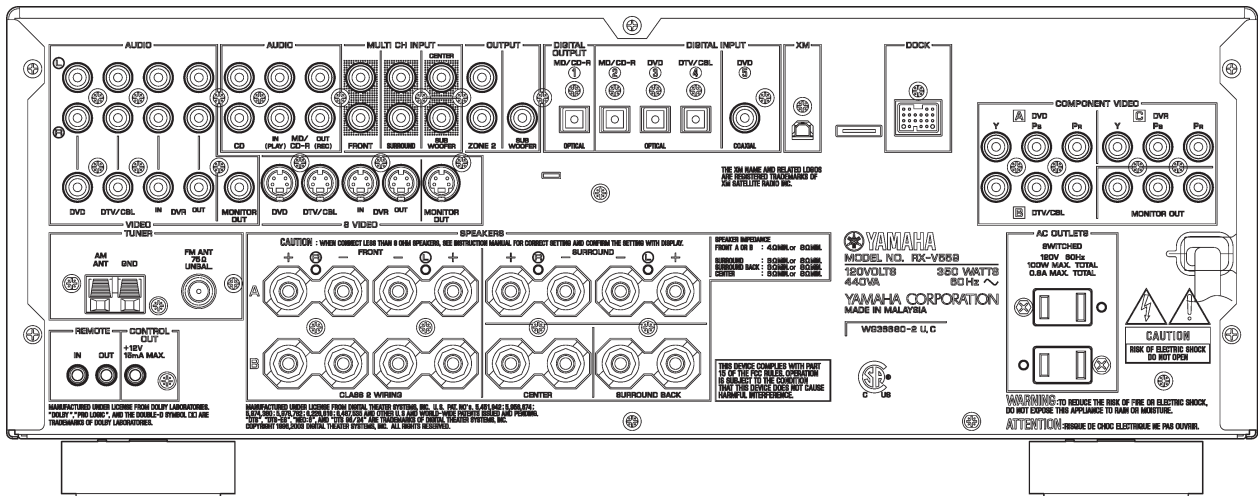

RX-V559 (R model)

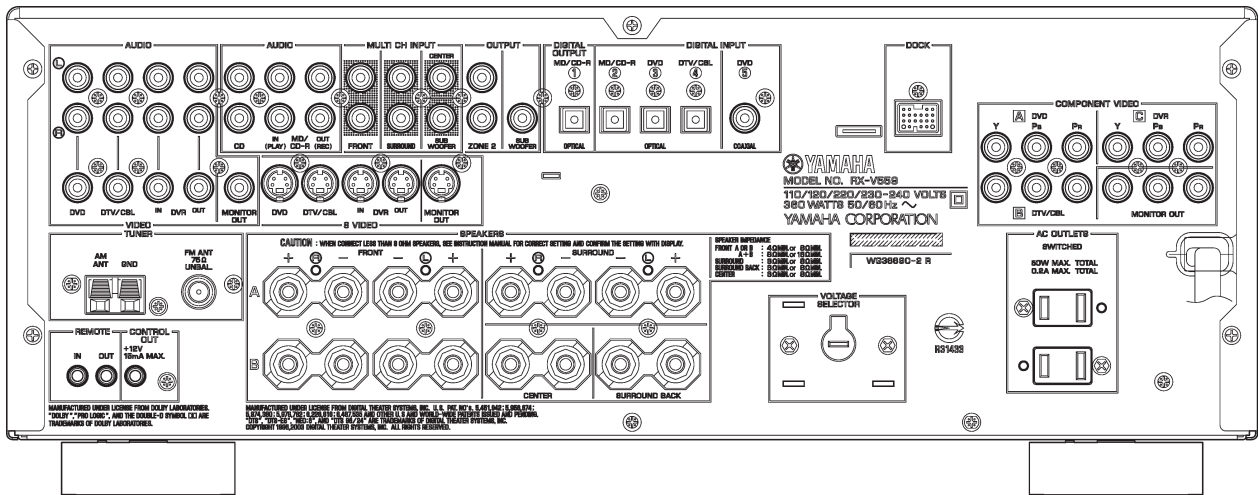

RX-V559 (T model)

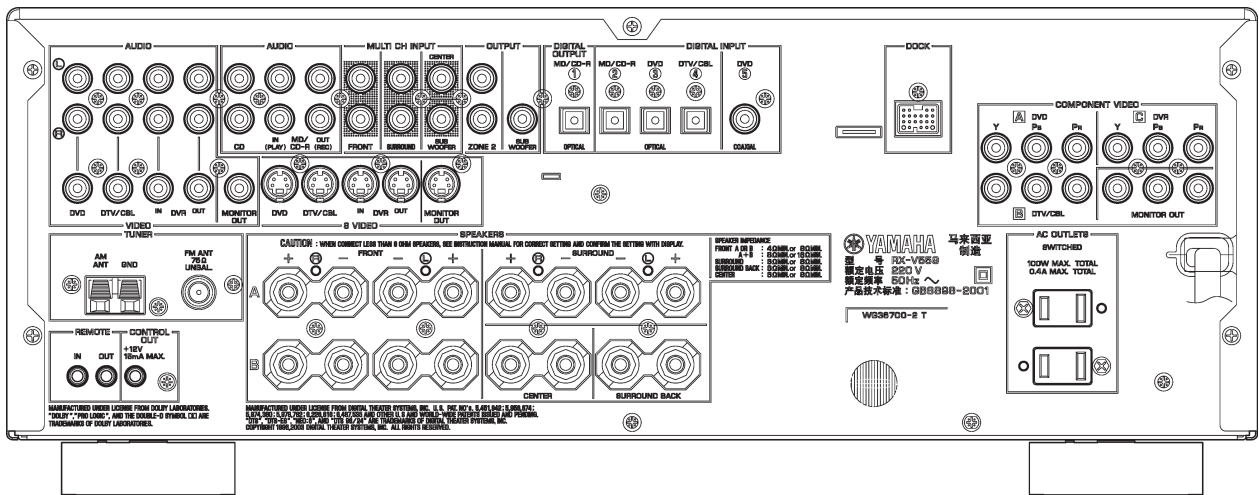

RX-V559/HTR-5950/DSP-AX559

RX-V559 (K model)

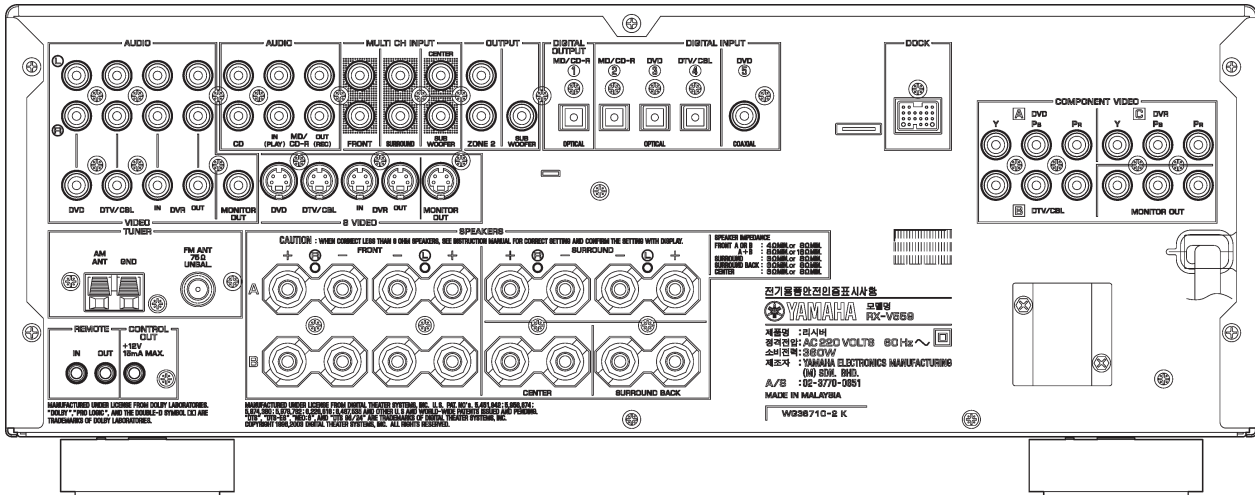

RX-V559 (A model)

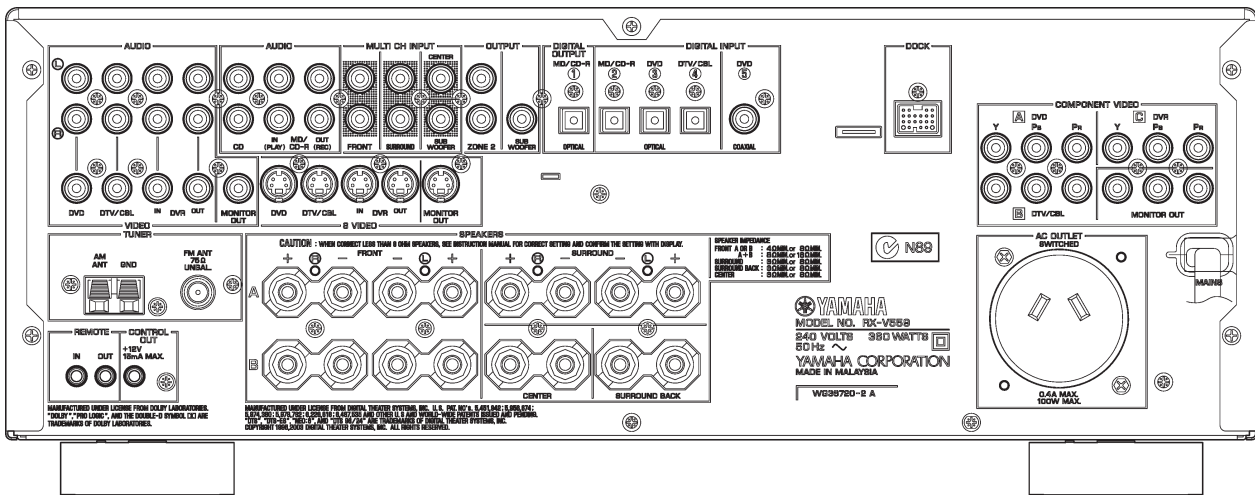

RX-V559 (G, E models)

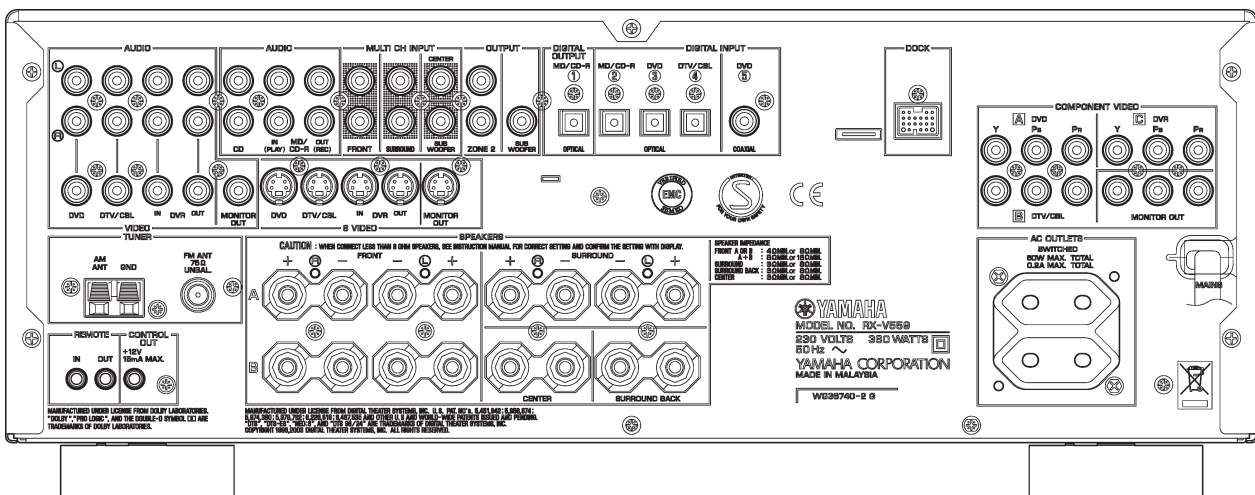

RX-V559/HTR-5950/DSP-AX559

RX-V559 (L model)

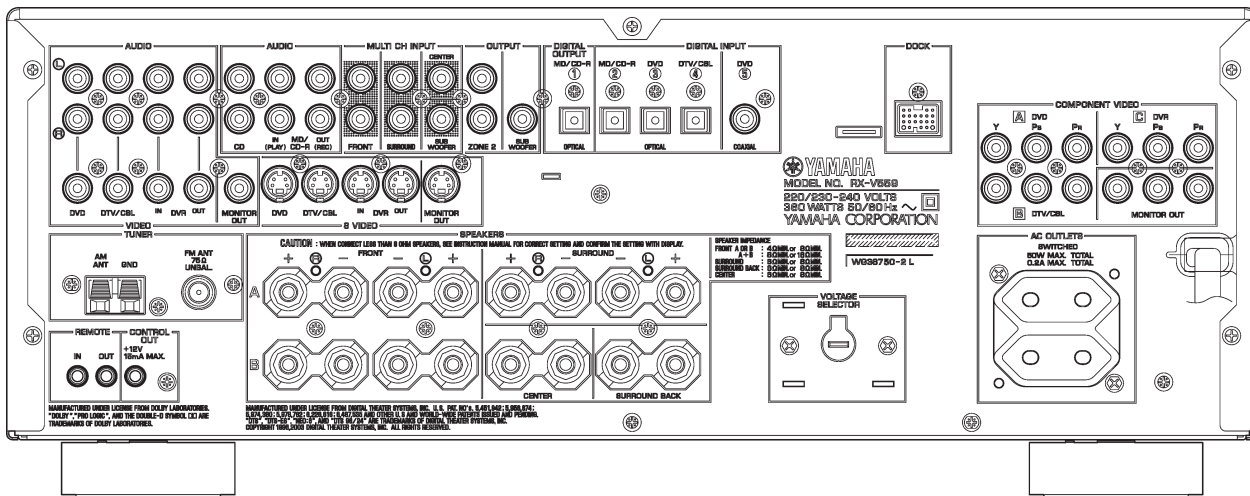

HTR-5950 (U, C models)

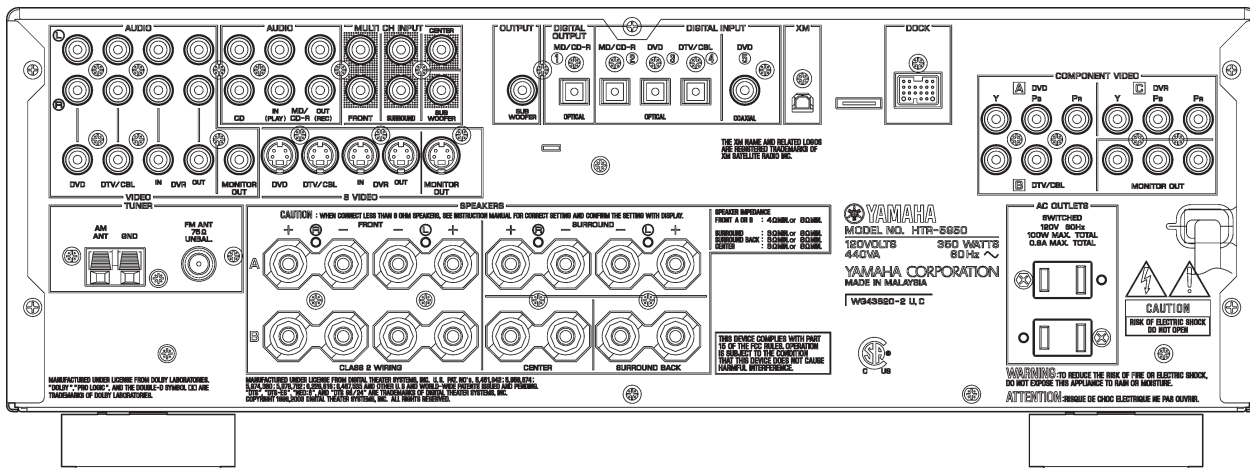

HTR-5950 (T model)

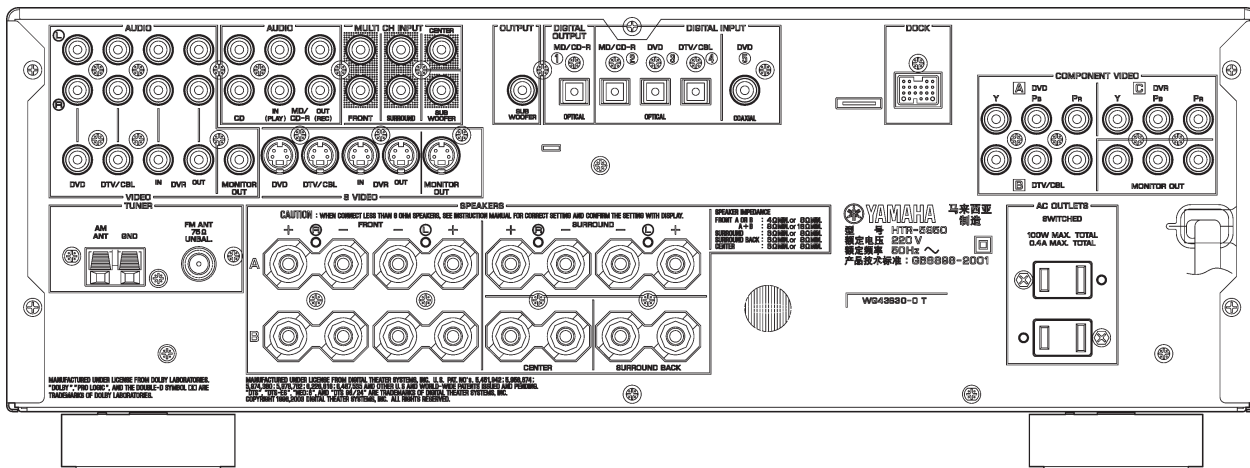

RX-V559/HTR-5950/DSP-AX559

HTR-5950 (A model)

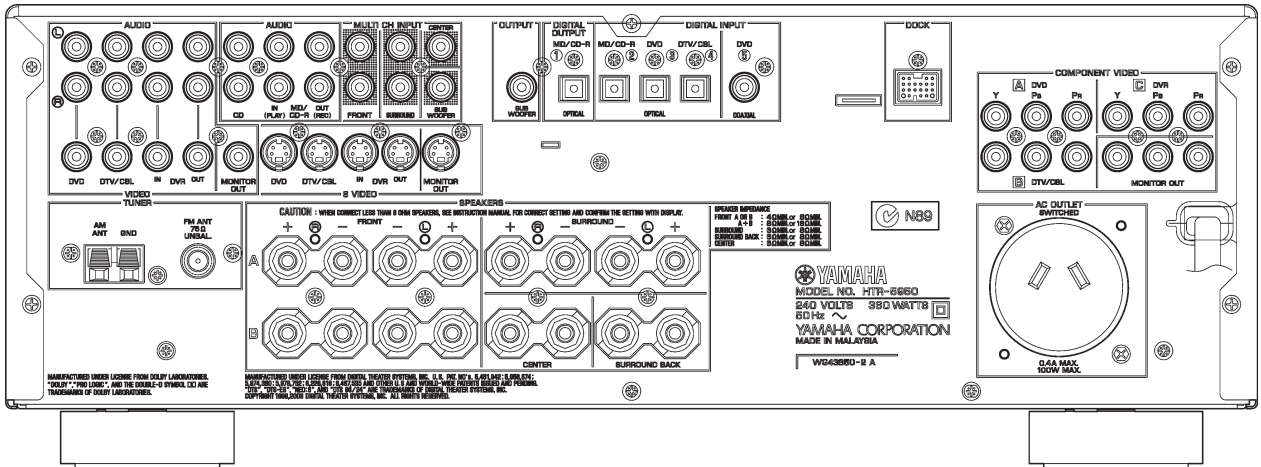

DSP-AX559 (J model)

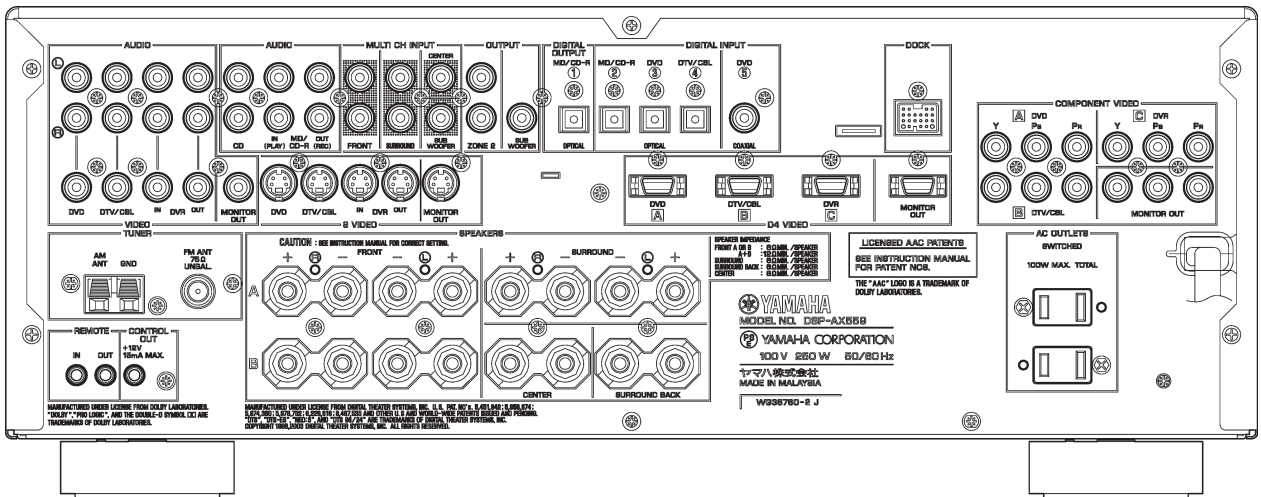

RX-V559/HTR-5950/
DSP-AX559

■ REMOTE CONTROL PANELS

RAV322

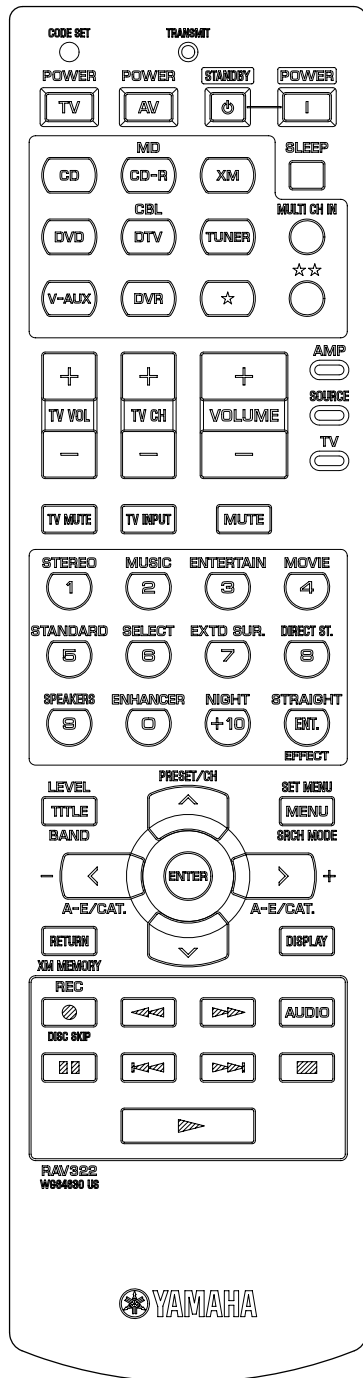

RX-V559 (U, C models)
HTR-5950 (U, C models)

RAV323

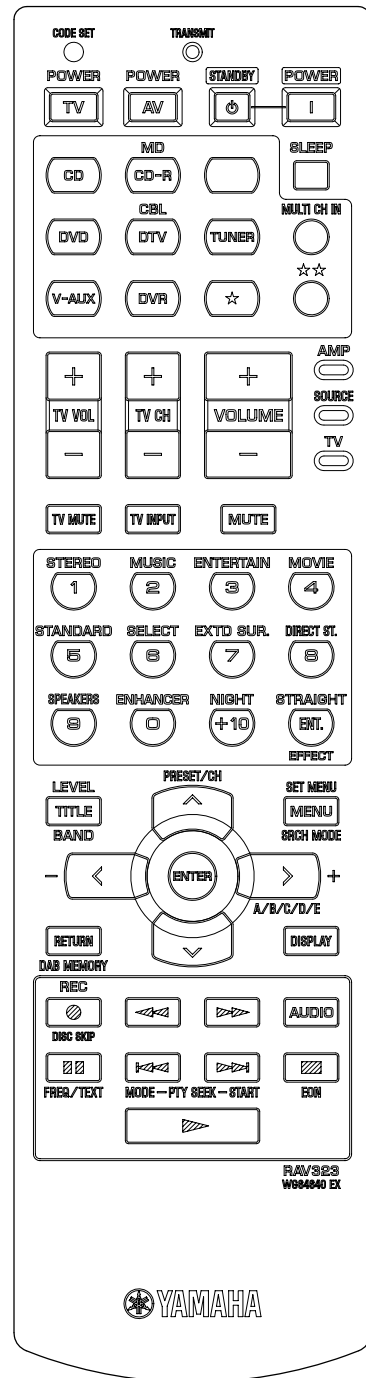

RX-V559 (R, T, K, A, G, E, L models)
HTR-5950 (T, A models)
DSP-AX559 (J model)

■ SPECIFICATIONS / 参考仕様

■ Audio Section / オーディオ部

Minimum RMS Output Power (Power Amp. Section) / 定格出力 (パワーアンプ部)

[RX-V559]
(20 Hz to 20 kHz, 0.06 % THD, 8 ohms)

FRONT L/R	95 W + 95 W
CENTER	95 W
SURROUND L/R	95 W + 95 W
SURROUND BACK	95 W

[HTR-5950]
(1 kHz, 0.7 % THD, 8 ohms)

FRONT L/R	110 W + 110 W
CENTER	110 W
SURROUND L/R	110 W + 110 W
SURROUND BACK	110 W

[DSP-AX559] (J model)
(20 Hz to 20 kHz, 0.09 % THD, 6 ohms)

FRONT L/R	95 W + 95 W
CENTER	95 W
SURROUND L/R	95 W + 95 W
SURROUND BACK	95 W

Maximum Power / 実用最大出力 (EIAJ) (1 kHz, 10 % THD)

[RX-V559/HTR-5950] (R, T, K, L models)

FRONT L/R (8 ohms)	135 W
CENTER (8 ohms)	135 W
SURROUND L/R (8 ohms)	135 W
SURROUND BACK (8 ohms)	135 W

[DSP-AX559] (J model)

FRONT L/R (6 ohms)	135 W
CENTER (6 ohms)	135 W
SURROUND L/R (6 ohms)	135 W
SURROUND BACK (6 ohms)	135 W

Maximum Power Per Channel / MAXパワー (SP IMPEDANCE SET: 8 ohms Minimum/1 kHz, 0.7 % THD 4ohms)

[RX-V559/HTR-5950] (G, E models)

FRONT L/R	145 W + 145 W
CENTER	145 W
SURROUND L/R	145 W + 145 W
SURROUND BACK	145 W

IEC Power / IECパワー (1 kHz, 0.06 % THD 8ohms)

[RX-V559/HTR-5950] (G, E, L models)

FRONT L/R	105 W + 105 W
-----------------	---------------

Dynamic Power Per Channel / ダイナミックパワー (IHF)

[RX-V559/HTR-5950]

FRONT L/R (8/6/4/2 ohms)	130/165/195/240 W
--------------------------------	-------------------

[DSP-AX559] (J model)

FRONT L/R (-/6/4/2 ohms)	-/135/165/210 W
--------------------------------	-----------------

Dynamic Headroom / ダイナミックヘッドルーム (8 ohms)

[RX-V559/HTR-5950] (U, C models)

	1.6 dB
--	--------

Damping Factor / ダンピングファクタ

FRONT L/R (20 Hz to 20 kHz, SPEAKER-A)

	120 or more
--	-------------

Input Sensitivity/Input Impedance / 入力感度/入力インピーダンス

CD, etc.

	200 mV / 47 k-ohms
--	--------------------

MULTI CH IN

FRONT L/R, CENTER, SURROUND L/R, SUBWOOFER

	200 mV / 47 k-ohms
--	--------------------

Maximum Input Signal Level / 最大許容入力 (1 kHz, 0.5% THD)

CD, etc. (Effect On)

	2.2 V or more
--	---------------

Output Level/Output Impedance / 出力電圧/出力インピーダンス

REC OUT

	200 mV / 1.2 k-ohms
--	---------------------

SUBWOOFER (2ch STEREO & FRONT SP: Small)

	4 V / 1.2 k-ohms
--	------------------

[RX-V559/DSP-AX559]

ZONE2 OUT	200 mV / 1.2 k-ohms
-----------------	---------------------

Headphone Jack Rated Output/Impedance / ヘッドフォン出力/出

カインピーダンス

CD, etc. (1 kHz, 50 mV, 8 ohms)

	150 mV / 100 ohms
--	-------------------

Frequency Response / 周波数特性

CD, etc. to FRONT L/R (10 Hz to 100 kHz)

	+0/-3.0 dB
--	------------

Total Harmonic Distortion / 全高調波歪率 (50 W, 8 ohms)

CD, etc. (2ch STEREO) to FRONT L/R SP OUT

	0.06 % or less
--	----------------

Signal to Noise Ratio / 信号対雑音比 (IHF-A Network)

CD, etc. (Input shorted) SP OUT

250 mV	100 dB or more
--------------	----------------

Residual Noise / 残留ノイズ (IHF-A Network)

FRONT L/R SP OUT

	150 μ V or less
--	---------------------

Channel Separation / チャンネルセパレーション

CD, etc. (Input 5.1 k-ohms shorted, 1 kHz/10 kHz)

	60 dB or more/45 dB or more
--	-----------------------------

Tone Control Characteristics / トーンコントロール特性

BASS

Boost/Cut	\pm 10 dB (60 Hz)
-----------------	---------------------

TREBLE

Boost/Cut	\pm 10 dB (20 kHz)
-----------------	----------------------

Filter Characteristics / フィルター特性

FRONT L/R, CENTER, SURROUND L/R, SURROUND BACK SP
Small (H.P.F.)

	fc= 40/60/80/90/100/110/120/160/200 Hz / 12 dB/oct.
--	-----------------------------------------------------

SUBWOOFER (L.P.F.)

	fc= 40/60/80/90/100/110/120/160/200 Hz / 24 dB/oct.
--	-----------------------------------------------------

■ Video Section / ビデオ部

Video Signal Type (Gray Back) / ビデオ信号方式(グレイバック)

U, C, R, K, J models

	NTSC
--	------

T, A, G, E, L models

	PAL
--	-----

Video Signal Type (Video Conversion) / ビデオ信号方式(ビデオコンバージョン)

U, C, R, T, K, A, G, E, L, J models

	NTSC/PAL
--	----------

Composite Video Signal Level / コンポジットビデオ信号

	1 Vp-p / 75 ohms
--	------------------

S-Video Signal Level / Sビデオ信号

Y	1 Vp-p / 75 ohms
C	0.286 Vp-p / 75 ohms

Component Signal Level / コンポーネントビデオ信号

Y	1 Vp-p / 75 ohms
Cb/Cr	0.7 Vp-p / 75 ohms

D4-Video Signal Level / D4端子ビデオ信号 (J model)

Y	1 Vp-p / 75 ohms
Cb/Cr	0.7 Vp-p / 75 ohms

Video Maximum Input Level / ビデオ最大許容入力

VIDEO CONV. OFF

	1.5 Vp-p or more
--	------------------

Signal to Noise Ratio / 信号対雑音比

	50 dB or more
--	---------------

Monitor Out Frequency Response / モニターアウト周波数帯域

(VIDEO CONV. OFF)

Component video signal level	5 Hz to 60 MHz, -3 dB
D4-video signal level (J model)	5 Hz to 60 MHz, -3 dB

■ FM Section / FM部

Tuning Range / 受信周波数範囲

U, C models	87.5 to 107.9 MHz
R, L models	87.5 to 108.00 MHz
T, K, A, G, E models	87.50 to 108.00 MHz
J model	76.0 to 90.0 MHz

50 dB Quieting Sensitivity / 50 dB SN感度 (IHF) (1 kHz, 100 % Mod.)

Mono / Stereo	2.0 μ V (17.3 dBf) / 25 μ V (39.2 dBf)
---------------------	------------------------------------------------

Usable Sensitivity / 実用感度 (IHF)

Mono	1.0 μ V (11.2 dBf)
------------	------------------------

Selectivity / 選択度 (at 400 kHz)

	70 dB
--	-------

Signal to Noise Ratio / 信号対雑音比 (IHF)

Mono / Stereo	76 dB / 70 dB
---------------------	---------------

Harmonic Distortion / 歪率 (1 kHz)

Mono/Stereo	0.2 / 0.3 %
-------------------	-------------

Stereo Separation / ステレオセパレーション

1 kHz	42 dB
-------------	-------

Frequency Response / 周波数特性

20 Hz to 15 kHz	+0.5 / -2 dB
-----------------------	--------------

Antenna Input / アンテナ入力

	75 ohms unbalanced
--	--------------------

■ AM Section / AM部

Tuning Range / 受信周波数範囲

U, C models	530 to 1,710 kHz
R, L models	530 to 1,710 / 531 to 1,611 kHz
T, K, A, G, E, J models	531 to 1,611 kHz

Usable Sensitivity / 実用感度

	300 μ V/m
--	---------------

Antenna / アンテナ入力

	Loop antenna
--	--------------

■ General / 総合

Power Supply / 電源電圧

R, C models	AC 120 V, 60 Hz
T model	AC 110/120/220/230/240 V, 50/60 Hz
K model	AC 220 V, 50 Hz
A model	AC 230 V, 50 Hz
G, E models	AC 240 V, 50 Hz
L model	AC 230 V, 50 Hz
J model	AC 220/230/240 V, 50/60 Hz
	AC 100V, 50/60 Hz

Power Consumption / 消費電力

R, T, K, A, G, E, L models	350 W / 440 VA
J model	360 W
	250 W

Standby Power Consumption (reference data) / 待機時消費電力 (参考値)

	0.1 W
--	-------

Maximum Power Consumption (R model)

6ch Drive, 10% THD	700 W
--------------------	-------

AC Outlets / ACアウトレット

2 Switched Outlets	
U, C, T, J models	100 W max. total
R, G, E, L models	50 W max. total
1 Switched Outlet	
A model	100 W max.

Dimensions / 寸法 (W x H x D)

[RX-V559/DSP-AX559]	435 x 171 x 393.2 mm (17-1/8" x 6-3/4" x 15-1/2")
[HTR-5950]	435 x 181 x 393.2 mm (17-1/8" x 6-5/16" x 15-1/2")

Weight / 質量

[RX-V559/DSP-AX559]	11.0 kg (24 lbs. 4 oz.)
[HTR-5950]	10.5 kg (23 lbs. 2 oz.)

Finish / 仕上げ

[RX-V559]	
Gold color	R, T, K models
Black color	U, C, R, A, G, E models
Titanium color	C, R, K, G, E, L models

[HTR-5950]

Gold color	T model
Black color	U, C models
Silver color	U, C, A models

[DSP-AX559]

Gold color	J model
------------	---------

Accessories / 付属品

Remote control x 1, Batteries x 2, Indoor FM antenna x 1, AM loop antenna x 1	
-------------------------------------------------------------------------------	--

* Specifications are subject to change without notice due to product improvements.

※ 参考仕様および外観は予告なく変更されることがあります。

U	U.S.A. model
R	General model
T	Canadian model
K	Chinese model
G	Australian model
E	South European model
L	Singapore model
J	Japanese model

• DIMENSIONS / 寸法図

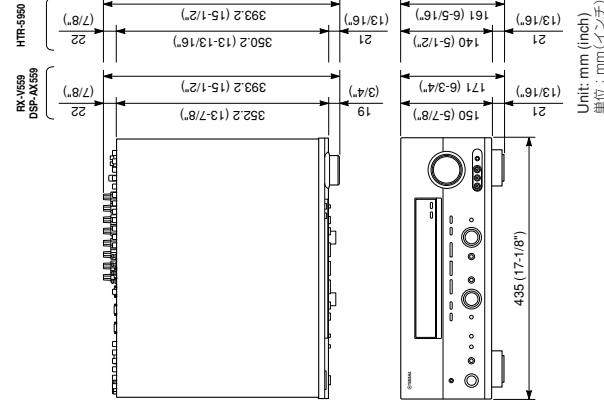

Unit: mm (inch)
単位: mm (インチ)

DOLBY DIGITAL EX
Manufactured under license from Dolby Laboratories. "Dolby", "Pro Logic", and the double-D symbol are trademarks of Dolby Laboratories.

ドルビーラボラトリーからの実施権により製造されています。「ドルビー」、「PRO LOGIC」、「Surround EX」およびダブルD記号は、ドルビーラボラトリーの商標です。

DTS
Manufactured under license from Digital Theater Systems, Inc. "DTS", "DTS-ES", "NEO6", and "DTS 96/24" are trademarks of Digital Theater Systems, Inc. Copyright 1996, 2003 Digital Theater Systems, Inc. All right reserved.
DTS, DTS-ES, Extended Surround, NEO.6およびDTS96/24はデジタルシアターシステムズの登録商標です。

iPod®
"iPod" is a trademark of Apple Computer, Inc., registered in the U.S. and other countries.
iPodは、米国およびその他の国々で登録されたApple Computer, Inc.の商標または登録商標です。

SILENT CINEMA
"SILENT CINEMA" is a trademark of YAMAHA CORPORATION.
[サイレントシネマ SILENT CINEMA]はヤマハ株式会社の登録商標です。



The XM name and related logos are registered trademarks of XM Satellite Radio Inc.



Neural Surround™ name and related logos are trademarks owned by Neural Audio Corporation.



AACロゴマークはドルビーラボラトリーの商標です。

CATEGORY	MAIN MENU	SUB MENU	SELECT MENU	VALUE [INITIAL]	
MANUAL SETUP	BASIC SETUP	ROOM	S / [M] / L		
		SUBWOOFER	[YES] / NONE		
		SPEAKER	2spk / 3spk / 4 spk / 5spk / [6spk]		
		SETUP	OK / CANCEL		
		CHECK OK?	YES / NO		
		A) SPEAKER SET	FRONT : LARGE	SMALL / [LARGE]	
			CENTER : SML	NONE / [SML] / LRG	
			SURROUND L/R : SML	NONE / [SML] / LRG	
			SURROUND BACK : SML	NONE / [SML] / LRG	
			PRESENCE : NONE	[NONE] / YES	
			LFE/BASS OUT : BOTH	SWFR / FRONT / [BOTH]	
			CROSS OVER : 80Hz	40 / 60 / [80] / 100 / 110 / 120 / 160 / 200 Hz	
	SUBWOOFER PHASE : NORMAL	[NORMAL] / REVERSE			
	B) SPEAKER LEVEL	FL : FR : C : SL : SR : SB : SWFR : UNIT	-10dB to +10dB [CENTER 0dB], 0.5dB step		
	C) SP DISTANCE	FRONT L : 10.0ft FRONT R : 10.0ft CENTER : 10.0ft SURR L : 10.0ft SURR R : 10.0ft SB : 7.0ft SWFR : 10.0ft FRONT L : 3.0m FRONT R : 3.0m CENTER : 3.0m SURR L : 3.0m SURR R : 3.0m SB : 2.10m SWFR : 3.0m	feet : 1.0 to 80.0 ft [10.0ft], 0.5 ft step meters : 0.30 to 24.00 m [3.00m], 0.10 m step		
	D) CENTER GEO	100Hz : 300Hz : 1kHz : 3kHz : 10kHz : TEST : OFF	-6.0 dB to +6.0 dB [0.0 dB], 0.5 dB step		
	E) LFE LEVEL	SPEAKER LFE : 0dB HEADPHONE LFE : 0dB	-20 dB to 0 dB [0 dB], 1 dB step		
	F) DYNAMIC RANGE	SPEAKER : MIN / STD / [MAX] HEADPHONE : MIN / STD / [MAX]			
	G) AUDIO SET	MUTING TYPE : FULL AUDIO DELAY : 0ms TONE BYPASS : AUTO / OFF	0 ms to 160 ms, 1 ms step		
2 INPUT MENU	A) I/O ASSIGNMENT	DUAL MONO : MAIN	[MAIN] / SUB / ALL (4 model)		
		CMPT-V INPUT [A]	[DVD] / DTV/CBL / V-AUX / VCR / DVR		
		CMPT-V INPUT [B]	DVD / DTV/CBL / V-AUX / VCR / DVR		
		CMPT-V INPUT [C]	DVD / DTV/CBL / V-AUX / VCR / DVR		
		OPTICAL OUT (1)	PHONO / CD / [MD/CD-R] / DVD / DTV/CBL / V-AUX / VCR / DVR		
		OPTICAL IN (2)	PHONO / CD / [MD/CD-R] / DVD / DTV/CBL / V-AUX / VCR / DVR		
		OPTICAL IN (3)	PHONO / CD / [MD/CD-R] / [DVD] / DTV/CBL / V-AUX / VCR / DVR		
		OPTICAL IN (4)	PHONO / CD / MD/CD-R / DVD / [DTV/CBL] / V-AUX / VCR / DVR		
		COAXIAL IN (5)	PHONO / [CD] / MD/CD-R / DVD / DTV/CBL / V-AUX / VCR / DVR		
		B) INPUT MODE	[AUTO] / LAST		
		C) INPUT RENAME	PHONO / CD / MD/CD-R / DVD / DTV/CBL / V-AUX / VCR / DVR		
		D) VOLUME TRIM	-6.0dB to +6.0dB [0dB] 0.5dB step		
3 OPTION MENU	A) DISPLAY SET	DIMMER : 0	PHONO / CD / MD/CD-R / DVD / DTV/CBL / V-AUX / VCR / DVR		
		VIDEO CONV. : ON	OFF / [ON]		
		OSD SHIFT : 0	-5 to +5, 1 step		
		GRAY BACK : AUTO	OFF / [AUTO]		
		MEMORY GUARD : OFF	[OFF] / ON		
		C) PARAM. INI	STEREO / MUSIC / ENTERTAINMENT / MOVIE THEATER / STANDARD		
		D) MULTI ZONE SET	SP B : FRONT	[FRONT] / ZONE B	
		E) XM RADIO SET	XM DISPLAY : 10S	[10S] / 30S / OFF	
			XM ANTENNA : NONE	0% to 100% / [NONE]	
			SCROLL : CONT	[CONT] / ONCE	

INTERNAL VIEW

• RX-V559, DSP-AX559

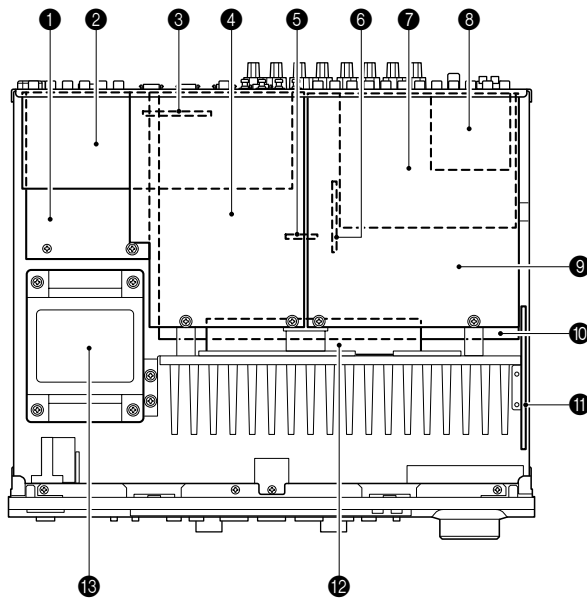

- ❶ OPERATION (4) P.C.B.
- ❷ FUNCTION (2) P.C.B.
- ❸ FUNCTION (3) P.C.B. (R, L models)
- ❹ DSP P.C.B.
- ❺ MAIN (5) P.C.B.
- ❻ MAIN (4) P.C.B.
- ❼ VIDEO P.C.B.
- ❽ Tuner
- ❾ FUNCTION (1) P.C.B.
- ❿ MAIN (1) P.C.B.
- ⓫ FUNCTION (4) P.C.B.
- ⓬ MAIN (2) P.C.B.
- ⓭ Power Transformer

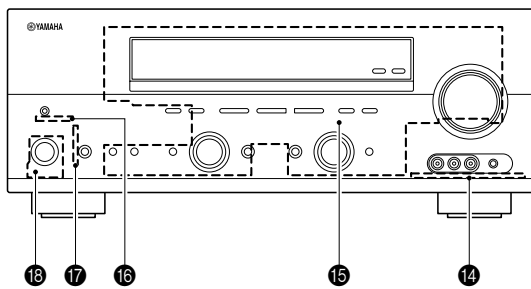

• HTR-5950

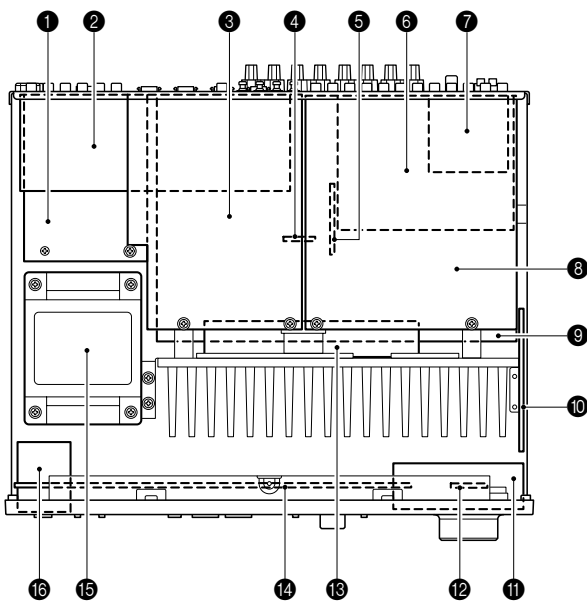

- ❶ OPERATION (4) P.C.B.
- ❷ FUNCTION (2) P.C.B.
- ❸ DSP P.C.B.
- ❹ MAIN (5) P.C.B.
- ❺ MAIN (4) P.C.B.
- ❻ VIDEO P.C.B.
- ❼ Tuner
- ❽ FUNCTION (1) P.C.B.
- ❾ MAIN (1) P.C.B.
- ❿ FUNCTION (4) P.C.B.
- ⓫ OPERATION (5) P.C.B.
- ⓬ OPERATION (6) P.C.B.
- ⓭ MAIN (2) P.C.B.
- ⓮ OPERATION (1) P.C.B.
- ⓯ Power Transformer
- ⓰ OPERATION (3) P.C.B.

RX-V559/DSP-AX559

DISASSEMBLY PROCEDURES / 分解手順

(Remove parts in the order as numbered.)
Disconnect the power cable from the AC outlet.

(番号順に部品を取り外してください。)
AC電源コンセントから、電源コードを抜いてください。

1. Removal of Top Cover

- a. Remove 4 screws (①), 5 screws (②) and 1 screw (③). (Fig. 1)
- b. Slide the Top Cover rearward to remove it. (Fig. 1)

1. トップカバーの外し方

- a. ①のネジ4本、②のネジ5本、③のネジ1本を外します。(Fig. 1)
- b. トップカバーを後方へスライドさせ、取り外します。(Fig. 1)

2. Removal of Front Panel Unit

- a. Remove 2 Knobs. (Fig. 1)
- b. Remove 1 screw (④) and then remove the Support Top. (Fig. 1)
- c. Remove 6 screws (⑤). (Fig. 1)
- d. Remove the Front Panel Unit. (Fig. 1)

2. フロントパネルユニットの外し方

- a. ノブを2個取り外します。(Fig. 1)
- b. ④のネジ1本を外し、サポートトップを取り外します。(Fig. 1)
- c. ⑤のネジ6本を外します。(Fig. 1)
- d. フロントパネルユニットを取り外します。(Fig. 1)

3. Removal of Plate Side

- a. Remove 2 push rivets (⑥). (Fig. 1)
- b. Remove the Plate Side L/R. (Fig. 1)

3. プレートサイドL/Rの外し方

- a. ⑥のプッシュリベット2本を外します。(Fig. 1)
- b. プレートサイドL/Rを取り外します。(Fig. 1)

4. Removal of Sub Chassis Unit

- a. Remove 2 screws (⑦) and then slide the Sub Chassis Unit forward. (Fig. 1)
- b. Remove a push rivet (⑧). (Fig. 1)
- c. Remove the Barrier/FFC. (Fig. 1)
- d. Remove CB5, CB203, CB205 and CB312. (Fig. 1)
- e. Remove the Sub Chassis Unit. (Fig. 1)

4. サブシャーシユニットの外し方

- a. ⑦のネジ2本を外し、サブシャーシユニットを前方に引き出します。(Fig. 1)
- b. ⑧のプッシュリベット1本を外します。(Fig. 1)
- c. バリアー/FFCを取り外します。(Fig. 1)
- d. CB5、CB203、CB205、CB312を外します。(Fig. 1)
- e. サブシャーシユニットを取り外します。(Fig. 1)

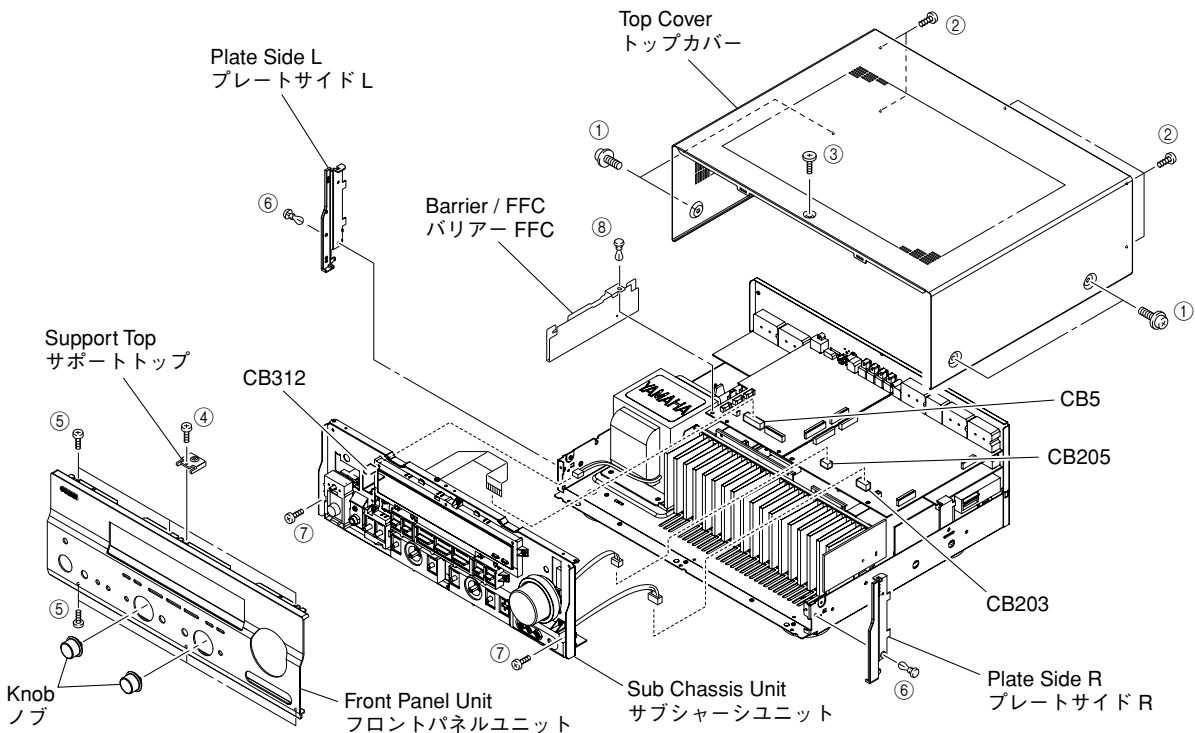

Fig. 1

RX-V559/HTR-5950/DSP-AX559

5. Removal of FUNCTION (1) P.C.B.

- a. Remove 2 screws (⑧). (Fig. 2)
- b. Remove 8 screws (⑨). (Fig. 4)
- c. Remove CB200-202, CB204, CB206 and CB207. (Fig. 2)
- d. Remove the FUNCTION (1) P.C.B.. (Fig. 2)

5. FUNCTION(1)P.C.B.の外し方

- a. ⑧のネジ2本を外します。(Fig. 2)
- b. ⑨のネジ8本を外します。(Fig. 4)
- c. CB200～202、CB204、CB206、CB207を外します。(Fig. 2)
- d. FUNCTION(1)P.C.B.を取り外します。(Fig. 2)

6. Removal of DSP P.C.B.

- a. Remove 2 screws (⑩). (Fig. 2)
- b. Remove 7 screws (U, C models) / 6 screws (R, T, K, A, G, E, L, J models) (⑪). (Fig. 4)
- c. Remove CB2-4, CB9 and CB57. (Fig. 2)
- d. Remove the DSP P.C.B.. (Fig. 2)

6. DSP P.C.B.の外し方

- a. ⑩のネジ2本を外します。(Fig. 2)
- b. ⑪のネジ6本を外します。(Fig. 4)
- c. CB2～4、CB9、CB57を外します。(Fig. 2)
- d. DSP P.C.B.を取り外します。(Fig. 2)

7. Removal of VIDEO P.C.B.

- a. Remove 1 push rivet (⑬). (Fig. 3)
- b. Remove 6 screws (⑭). (Fig. 4)
- c. Remove CB401 and CB402. (Fig. 3)
- d. Remove the VIDEO P.C.B.. (Fig. 3)

7. VIDEO P.C.B.の外し方

- a. ⑬のプッシュリベット1本を外します。(Fig. 3)
- b. ⑭のネジ6本を外します。(Fig. 4)
- c. CB401、CB402を外します。(Fig. 3)
- d. VIDEO P.C.B.を取り外します。(Fig. 3)

DSP P.C.B. FUNCTION (1) P.C.B.

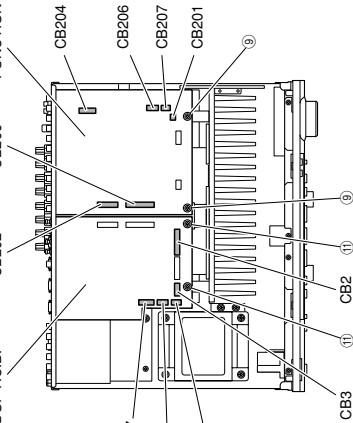

Fig. 2

FUNCTION (2) P.C.B. VIDEO P.C.B.

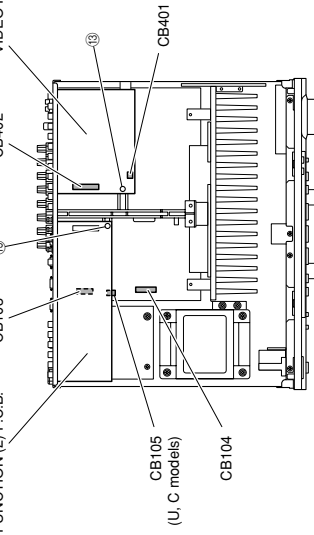

Fig. 3

8. Removal of FUNCTION (2) P.C.B.

- a. Remove 1 push rivet (⑮). (Fig. 3)
- b. Remove 5 screws (⑯). (Fig. 4)
- c. Remove the FUNCTION (2) P.C.B.. (Fig. 3)

8. FUNCTION(2)P.C.B.の外し方

- a. ⑮のプッシュリベット1本を外します。(Fig. 3)
- b. ⑯のネジ5本を外します。(Fig. 4)
- c. FUNCTION(2)P.C.B.を取り外します。(Fig. 3)

9. Removal of TUNER

- a. Remove 3 screws (⑰). (Fig. 4)
- b. Remove the TUNER. (Fig. 5)

9. TUNERの外し方

- a. ⑰のネジ3本を外します。(Fig. 4)
- b. TUNERを取り外します。(Fig. 5)

10. Removal of MAIN (1), (2), (4) and (5) P.C.B.s

- a. Remove the Airbase/P.C.B.. (Fig. 5)
- b. Remove 2 screws (⑱), 1 screw (⑲), 2 screws (⑳) and 1 screw (㉑). (Fig. 5)
- c. Remove 5 screws (㉒). (Fig. 4)
- d. Remove CB103, CB104 and CB105 (U, C models). (Fig. 3)
- e. Remove MAIN (1), (2), (4) and (5) P.C.B.s together with the Heat Sink. (Fig. 5)

10. MAIN(1)、(2)、(4)、(5)P.C.B.の外し方

- a. アートベース/PCBを取り外します。(Fig. 5)
- b. ⑱のネジ2本、⑲のネジ1本、⑳のネジ2本、㉑のネジ1本を外します。(Fig. 5)
- c. ㉒のネジ5本を外します。(Fig. 4)
- d. CB103、CB104を外します。(Fig. 3)
- e. MAIN(1)、(2)、(4)、(5)P.C.B.をヒートシンクと一緒に取り外します。(Fig. 5)

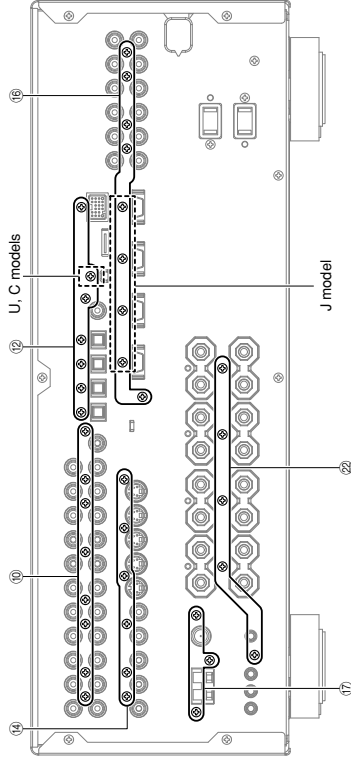

Fig. 4

Airbase / P.C.B. アートベース / P.C.B.

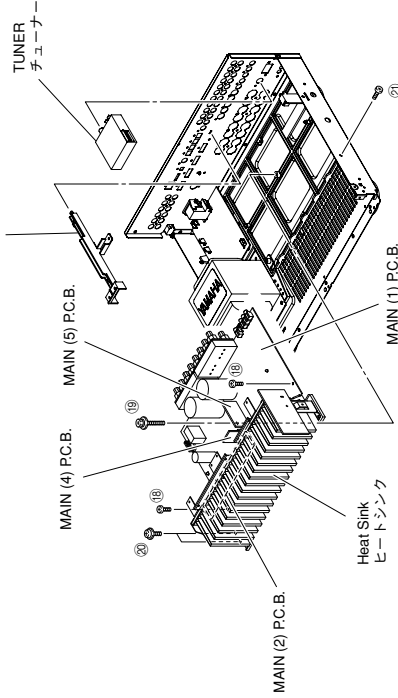

Fig. 5

When checking the P.C.B.:

- Put a Cloth over the equipment. Put the P.C.B.s together with the Heat Sink upright on the Cloth and check them. (Fig. 6)
- Reconnect all cables (connectors) that have been disconnected.
- When connecting the flat cable, use care for the polarity.
- The P.C.B. removed from the chassis does not work because its grounding is loose. Be sure to connect the ground of Rear Panel MAIN (1) P.C.B. (G1001) and OPERATION (4) P.C.B. (G3001) to the chassis with a ground lead or the like. (Fig. 6)

P.C.B.チェックする場合

- 布を敷きます。その上にP.C.B.をヒートシンクと一緒に立ててチェックします。(Fig. 6)
- 外したケーブル(コネクタ)をすべて接続してください。
- フラットケーブルを接続する際、極性に注意してください。
- シャーシから外したP.C.B.はアースが浮いて動作しませんので、MAIN(1)P.C.B.(G1001)、OPERATION(4)P.C.B.(G3001)のアースをリード線等でシャーシまたはGNDに接続してください。(Fig. 6)

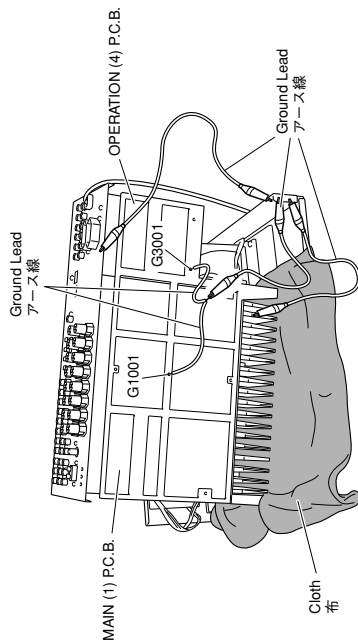

Fig. 6

HTR-5950

DISASSEMBLY PROCEDURES

(Remove parts in the order as numbered.)

Disconnect the power cable from the AC outlet.

1. Removal of Top Cover

- Remove 4 screws (1), 5 screws (2) and 1 screw (3). (Fig. 1)
- Slide the Top Cover rearward to remove it. (Fig. 1)

2. Removal of Front Panel Unit

- Remove 6 screws (4). (Fig. 1)
- Remove a push rivet (5). (Fig. 1)
- Remove the Barrier/FFC. (Fig. 1)
- Remove CB5, CB203, CB205 and CB310. (Fig. 1)
- Remove the Front Panel Unit. (Fig. 1)

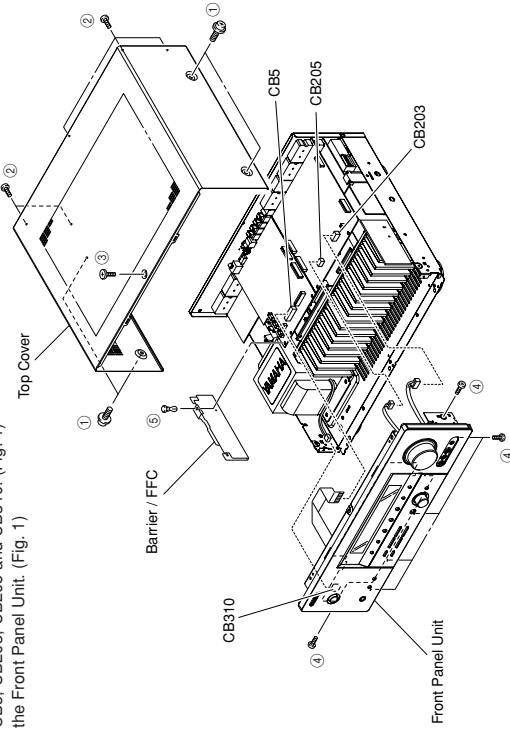

Fig. 1

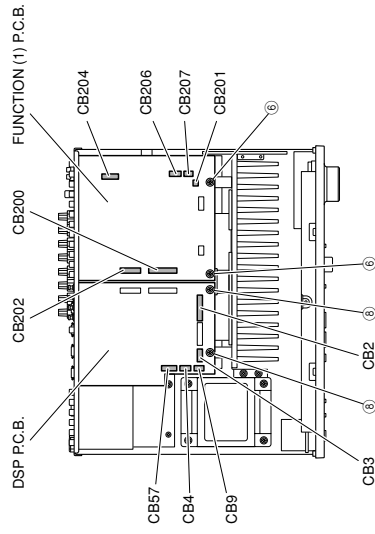

Fig. 2

4. Removal of DSP P.C.B.

- a. Remove 2 screws (⑥). (Fig. 2)
- b. Remove 7 screws (U, C models) / 6 screws (T, A models) (⑦). (Fig. 4)
- c. Remove CB2-4, CB9 and CB57. (Fig. 2)
- d. Remove the DSP P.C.B.. (Fig. 2)

5. Removal of VIDEO P.C.B.

- a. Remove 1 push rivet (⑩). (Fig. 3)
- b. Remove 6 screws (⑪). (Fig. 4)
- c. Remove CB401 and CB402. (Fig. 3)
- b. Remove the VIDEO P.C.B.. (Fig. 3)

6. Removal of FUNCTION (2) P.C.B.

- a. Remove 1 push rivet (⑫). (Fig. 3)
- b. Remove 5 screws (⑬). (Fig. 4)
- c. Remove the FUNCTION (2) P.C.B.. (Fig. 3)

7. Removal of TUNER

- a. Remove 3 screws (⑭). (Fig. 4)
- b. Remove the TUNER. (Fig. 5)

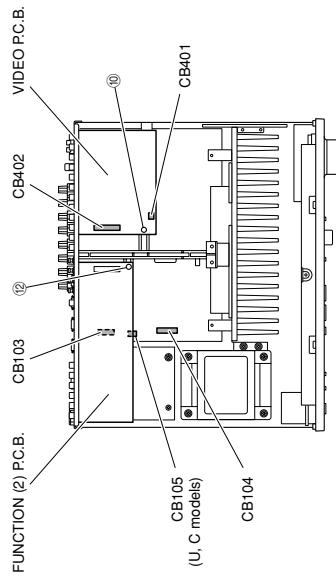

Fig. 3

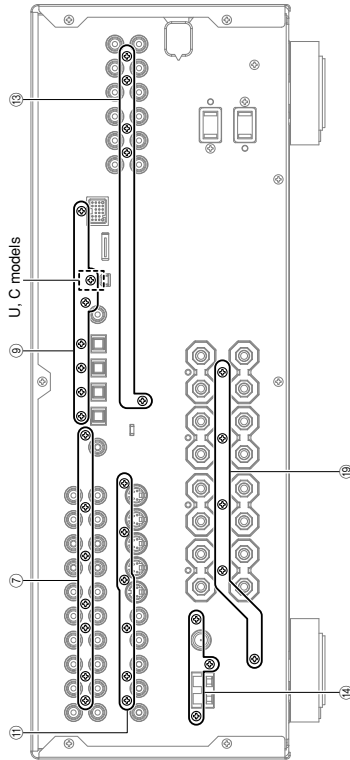

Fig. 4

8. Removal of MAIN (1), (2), (4) and (5) P.C.B.s

- a. Remove the Arbase/P.C.B.. (Fig. 5)
- b. Remove 2 screws (⑮), 1 screw (⑯), 2 screws (⑰) and 1 screw (⑱). (Fig. 5)
- c. Remove 5 screws (⑲). (Fig. 4)
- d. Remove CB103, CB104 and CB105 (U, C models). (Fig. 3)
- e. Remove MAIN (1), (2), (4) and (5) P.C.B.s together with the Heat Sink. (Fig. 5)

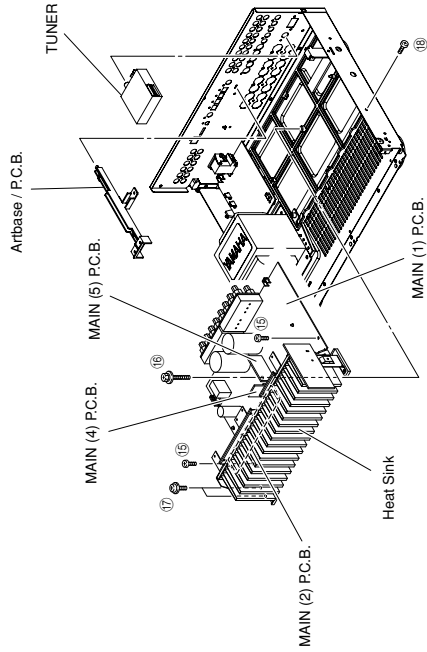

Fig. 5

When checking the P.C.B.:

- Put a Cloth over the equipment. Put the P.C.B.s together with the heat sink upright on the Cloth and check them. (Fig. 6)
- Reconnect all cables (connectors) that have been disconnected.
- When connecting the flat cable, use care for the polarity.
- The P.C.B. removed from the chassis does not work because its grounding is loose. Be sure to connect the ground of Rear Panel, MAIN (1) P.C.B. (G1001) and OPERATION (4) P.C.B. (G3001) to the chassis with a ground lead or the like.

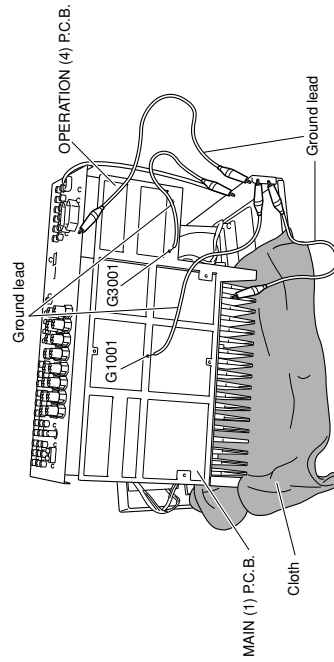

Fig. 6

■ SELF DIAGNOSIS FUNCTION (DIAG)/自己診断機能 (ダイアグ)

This unit has self diagnosis functions that are intended for inspection, measurement and location of faulty point. There are 23 DIAG menu items, each of which has sub-menu items.
Listed in the table below are menu items and sub-menu items.

Note that not all menu items listed will apply to the models covered in this service manual.

本機には、検査、測定、不良箇所の発見を目的とした自己診断機能(ダイアグ)があります。
ダイアグメニューは23個あり、それぞれにサブメニューがあります。(ダイアグのメニュー操作は本機で行います。) 下表はメニュー一覧です。
下表の全メニュー項目が、このサービスマニュアル記載のモデルに適用されるとは限りません。

No.	MAIN MENU	SUB MENU
1	BYPASS	1. ANALOG BYPASS 2. DSP BYPASS
2	RAM THR	1. RAM MARGIN 2. RAM FULL BIT
3	PRO LOGIC	1. Pro Logic
4	SPEAKERS SET	1. FRONT : SMALL 0dB 2. CENTER : NONE 3. LFE/B : FRNT 4. Pres Mix : 5ch 5. Front GAIN 1 6. Front GAIN 2 7. SURR B Check
5	XCH-INPUT	1. XCH INPUT_6 2. XCH INPUT_8 3. LIMIT SET (Not applied to these models / このモデルには適用されません)
6	MIC CHECK (Not applied to these models / このモデルには適用されません)	1. MIC CHECK --dB
7	DISPLAY CHECK	1. STRAIGHT (Initial display) 2. VFD DISP OFF / OSD OFF 3. VFD DISP ALL / OSD CHARACTER PATTERN 4. VFD DIMMER / OSD CHARACTER PATTERN 5. CHECK PATTERN / OSD CHARACTER PATTERN
8	MANUAL TEST	1. TEST ALL 2. TEST FRNT L 3. TEST CENTER 4. TEST FRNT R 5. TEST SURR R 6. TEST SB R (Not applied to these models / このモデルには適用されません) 7. TEST SBL 8. TEST SURR L 9. TEST PRES L (Not applied to these models / このモデルには適用されません) 10. TEST PRES R (Not applied to these models / このモデルには適用されません) 11. TEST LFE 1. PRESET INHI (memory initialization inhibited) 2. PRESET RSRV (memory initialized)
9	FACTORY PRESET	1. PS1/PS2
10	AD DATA CHECK	1. DC/TH 2. DC/TH 3. IMP SW/POWER LIMITER DISP
11	VIDEO	1. I2C Read Check 2. DIGITAL THR CVBS 3. DIGITAL THR Y/C 4. ANALOG BYPASS 5. TEST PATTERN 6. LOOP BACK CVBS (Not applied to these models / このモデルには適用されません) 7. LOOP BACK Y/C (Not applied to these models / このモデルには適用されません) 1. 1k -1dB / 44.1k 2. 1k -61dB / 44.1k 3. Mute / 44.1k 4. XM Tone / 44.1k 5. ISO Tone / 44.1k 6. 1k -1dB / 32k 7. 1k -61dB / 32k 8. Mute / 32k
12	XM STATUS (U.C models)	
13	iPod	
14	IF STATUS	9. XM Tone / 32k 10. ISO Tone / 32k 11. XM /DT Bus Power : OFF 1. DOCK : OK/NG
15	DSP STATUS (5Byte)	1. DSP STATUS (5Byte) (Not applied to these models / このモデルには適用されません)
16	DECODE MODE (2Byte)	2. DECODE MODE (2Byte) (Not applied to these models / このモデルには適用されません)
17	DIR INFO (2Byte)	3. DIR INFO (2Byte) (Not applied to these models / このモデルには適用されません)
18	Pc (2Byte)	4. Pc (2Byte) (Not applied to these models / このモデルには適用されません)
19	CHS 1 (5Byte)	5. CHS 1 (5Byte) (Not applied to these models / このモデルには適用されません)
20	CHS 2 (1Byte)	6. CHS 2 (1Byte) (Not applied to these models / このモデルには適用されません)
21	DEC INFO (5Byte)	7. DEC INFO (5Byte) (Not applied to these models / このモデルには適用されません)
22	BSI 1 (5Byte)	8. BSI 1 (5Byte) (Not applied to these models / このモデルには適用されません)
23	BSI 2 (5Byte)	9. BSI 2 (5Byte) (Not applied to these models / このモデルには適用されません)
24	BSI 3 (5Byte)	10. BSI 3 (5Byte) (Not applied to these models / このモデルには適用されません)
25	BSI 4 (5Byte)	11. BSI 4 (5Byte) (Not applied to these models / このモデルには適用されません)
26	BSI 5 (5Byte)	12. BSI 5 (5Byte) (Not applied to these models / このモデルには適用されません)
27	BSI 6 (5Byte)	13. BSI 6 (5Byte) (Not applied to these models / このモデルには適用されません)
28	BSI 7 (5Byte)	14. BSI 7 (5Byte) (Not applied to these models / このモデルには適用されません)
29	BSI 8 (1Byte)	15. BSI 8 (1Byte) (Not applied to these models / このモデルには適用されません)
30	Mute Trigger (5Byte)	16. Mute Trigger (5Byte) (Not applied to these models / このモデルには適用されません)
31	Digital Info (5Byte)	17. Digital Info (5Byte) (Not applied to these models / このモデルには適用されません)
32	TI (DSP) BUS CHECK	1. TI (DSP) BUS CHECK
33	RDS-IC CHECK	1. RDS-IC CHECK
34	SWFR CUT OFF (Not applied to these models / このモデルには適用されません)	1. L CUT OFF
35	H CUT OFF	2. H CUT OFF
36	PROTECTION SETTING (Not applied to these models / このモデルには適用されません)	1. PS L 2. PS H 3. DC L 4. DC H 5. TEMP 6. PL J 8 L 7. PL J 8 H 8. PL U 8 L 9. PL U 8 H 10. PL U N L 11. PL U N H 12. PL G 8 L 13. PL G 8 H 14. PL G N L 15. PL G N H
37	HISTORY 1	1. HISTORY 1
38	HISTORY 2	2. HISTORY 2
39	HISTORY 3	3. HISTORY 3
40	HISTORY 4	4. HISTORY 4
41	SW MODE : PCB/MODEL/FNC	1. SW MODE : PCB/MODEL/FNC
42	MODEL : 759SE-5935	2. MODEL : 759SE-5935
43	DEST : JUC/R/T/K/A/BGE/L	3. DEST : JUC/R/T/K/A/BGE/L
44	TUNER DEST : JUC/ATK/BG/RL	4. TUNER DEST : JUC/ATK/BG/RL
45	TUNER TYPE : NRM/RDS/XM	5. TUNER TYPE : NRM/RDS/XM
46	VIDEO FORMAT : NTSC/PAL	6. VIDEO FORMAT : NTSC/PAL
47	ZONE2 EXIST : EXIST/NOT	7. ZONE2 EXIST : EXIST/NOT
48	AAC EXIST : EXIST/NOT	8. AAC EXIST : EXIST/NOT
49	TUNER EXIST : EXIST/NOT	9. TUNER EXIST : EXIST/NOT
50	ZONE2 AMP EXIST : EXIST/NOT	10. ZONE2 AMP EXIST : EXIST/NOT
51	OSD EXIST : EXIST/NOT	11. OSD EXIST : EXIST/NOT
52	YPAO EXIST : EXIST/NOT	12. YPAO EXIST : EXIST/NOT
53	MICROPROCESSOR VERSION	1. MICROPROCESSOR VERSION
54	SUM ALL / PROGRAM	2. SUM ALL / PROGRAM
55	OPF / DSP / XM VERSION	3. OPF / DSP / XM VERSION
56	PORT	4. PORT
57	TI (DSP) FLASH VERSION	5. TI (DSP) FLASH VERSION
58	TI (DSP) FLASH SUM	6. TI (DSP) FLASH SUM
59	EEPROM SUM	7. EEPROM SUM
60	TI (DSP) FLASH BOOT (Not applied to these models / このモデルには適用されません)	1. TI (DSP) FLASH BOOT

● Starting DIAG

Press the “MASTER ON/OFF” (RX-V559/DSP-AX559 models) / “STANDBY/ON” (HTR-5950 model) key while simultaneously pressing those two keys of the main unit as indicated in the figure below.

Keys of main unit / 本体キー

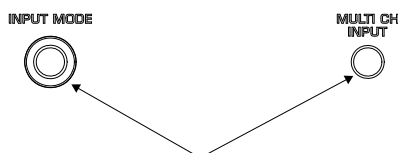

Turn on the power while pressing these keys.
これらのキーを同時に押しながら、パワーオンする。



RX-V559/DSP-AX559 models

HTR-5950 model

● Starting DIAG in the protection cancel mode

If the protection function works and causes hindrance to trouble diagnosis, cancel the protection function as described below, and it will be possible to enter the DIAG mode. (The protection functions other than the excess current detect function will be disabled.)

Press the “MASTER ON/OFF” (RX-V559/DSP-AX559 models) / “STANDBY/ON” (HTR-5950 model) key while simultaneously pressing those two keys indicated in the figure above. At this time, keep pressing those two keys for 3 seconds or longer.

In this mode, the “SLEEP” segment of the FL display of the main unit flashes to indicate that the mode is DIAG mode with the protection functions disabled.

CAUTION!

Using this product with the protection function disabled may cause damage to itself. Use special care for this point when using this mode.

● Canceling DIAG

- ① Before canceling DIAG, execute setting for FACTORY PRESET of DIAG menu No.9 (Memory initialization inhibited or Memory initialized).
 - * In order to keep the user memory stored, be sure to select PRESET INHIBITED (Memory initialization inhibited).
- ② Turn off the power by pressing the “MASTER ON/OFF” (RX-V559/DSP-AX559 models) / “STANDBY/ON” (HTR-5950 model) key of the main unit.

● ダイアグの起動

本体の下図に示すキーを同時に押しながら“MASTER ON/OFF”キーを押すと、ダイアグが起動します。

● プロテクション解除モードでの起動

プロテクションが動作することにより、故障箇所の診断に支障をきたすような場合は、次の方法によりプロテクションを解除した状態でダイアグモードに入ることができます。(過電流検出以外のプロテクション動作を解除する)

上図のキーを同時に押しながら“MASTER ON/OFF”キーを押します。このとき、上図のキーを3秒以上押し続けてください。このモードでは本体FLの“SLEEP”セグメントが点滅し、プロテクションを解除した状態でのダイアグモードであることを知らせます。

注意！

プロテクションを解除した状態でのダイアグモードは、危険な状態でもプロテクションが作動しないため、動作させると、機器を破壊することがあります。このモードを使用する場合は十分注意してください。

● ダイアグの解除

- ① ダイアグを解除する前に、ダイアグメニューNo.9のFACTORY PRESET (メモリーの初期化禁止/またはメモリーの初期化)の設定をします。
 - ※ ユーザーメモリーを保持したい場合は、必ずPRESET INHIBITED (メモリー初期化禁止)を選択してください。
- ② 本体の“MASTER ON/OFF”キーを押し、パワーオフにします。

● Display provided when DIAG started

When the monitor is connected, DIAGNOSTIC MENU appears on its screen as shown in the figure.

On the FL display of the main unit, an opening message (including the version and the protection history) appears for a few seconds followed by the diagnostic menu display (1. ANALOG BYPASS).

```

1.BYPASS      13.DOCK TEST
2.RAM THR     [14.Net]
3.PRO LOGIC   [15.DAB]
4.SP SET      16.IF STATUS
5.XCH INPUT   17.DSP BUS
6.MIC CHECK   18.SWF C. OFF
7.VFD CHECK   19.PRT SET
8.MAN'L TEST  20.PRT HIST
9.PRESET      21.SOFT SW
10.AD CHECK   22.VER/SUM/P
11.VC STATUS  23.TI BOOT
12.XM TEST
    
```

● ダイアグ起動時の表示

モニターを接続してある場合は、モニターの画面に図のようにダイアグメニューが表示されます。

本体FLディスプレイには、オープニング(プロテクション履歴/バージョン)が表示され、数秒後にダイアグメニュー表示(1. ANALOG BYPASS)となります。

When there is no history of protection function:

プロテクション履歴が無い場合:

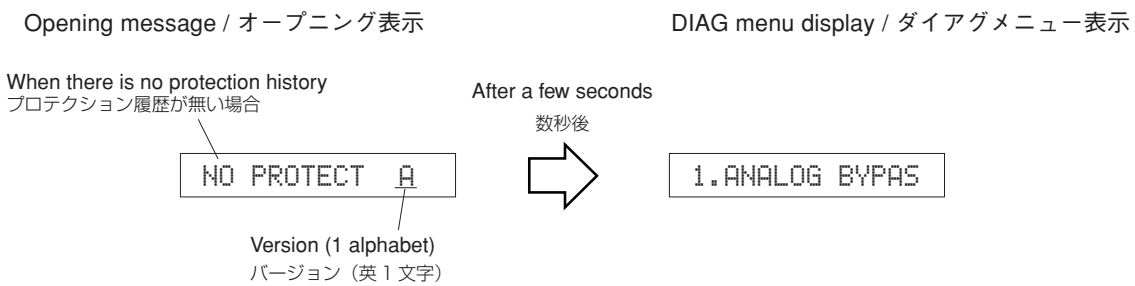

When there is a history of protection function:

プロテクション履歴がある場合:

The FL display appears as shown below depending on the type of the protection function.

プロテクションの種類によって下記の表示が現れます。

The protection function worked due to excessive current through the amplifier. Causes could be a short at the speaker terminal or a defect in the amplifier. The protection function activates immediately to turn off the power, with no history display at turn-on, if the amplifier is defective.

```
I PROTECT A
```

スピーカーをショートさせた時などが原因で、プロテクションが働いたことを示します。

The protection function worked due to a defect or overload in the power supply. If the power is turned on with the abnormality unsolved, the protection function works in about 1 second to turn off the power.

```
PS1 PRT:000 A
or
PS2 PRT:000 A
```

電源電圧による原因で、プロテクションが働いたことを示します。異常状態のままパワーオンすると、約1秒後にプロテクションが掛かり、電源が切れます。

The protection function worked due to a DC voltage appearing at the speaker terminal. A cause could be a defect in the amplifier. If the power is turned on with the abnormality unsolved, the protection function works in about 3 seconds to turn off the power.

```
DC PRT:000 A
```

アンプの故障でスピーカーに直流電圧が掛かるなどが原因で、プロテクションが働いたことを示します。異常状態のままパワーオンすると、約3秒後にプロテクションが掛かり、電源が切れます。

RX-V559/HTR-5950/DSP-AX559

The protection function worked due to the temperature limit being exceeded. Causes could be poor ventilation or a defect related to the thermal sensor. If the power is turned on with the abnormality unsolved, the protection function works in about 1 second to turn off the power.

TMP PRT:000 A

温度制限を越えた原因で、プロテクションが働いたことを示します。異常状態のままパワーオンすると、約1秒後にプロテクションが掛かり、電源が切れます。

For detection of each protection function (except I-PROTECT) , refer to DIAG MENU No.10 AD DATA.

各プロテクションの検出に関しては、後述のダイアグメニュー No. 10 AD DATAを参照してください。

History of protection function

When the protection function has worked, its history is stored in memory with a backup. Even if no abnormality is noted while servicing the unit, an abnormality which has occurred previously can be defined as long as the backup data has been stored.

The history of the protection function is cleared when DIAG is cancelled by selecting PRESET RESERVED (Memory initialized) of DIAG menu No.9 or when the backup data is erased.

プロテクションの履歴

プロテクションが働いた場合、履歴をバックアップして記憶しています。サービスのときに異常が認められなくても、バックアップが残っていれば、お客様のところで起きた異常を区別できます。

ダイアグメニュー No.9 で PRESET RESERVED (メモリーの初期化) を選んでダイアグを解除した場合、またはバックアップが消えた場合に、プロテクションの履歴はクリアされます。

● Display during menu operation

During the DIAG operation, the menu list described in the section of the startup screen appears on the monitor screen and the function at work is indicated on the FL indicator. The contents displayed during the function operation are described later in the “Details of DIAG menu” section.

● メニュー動作中の表示

ダイアグ中、モニター画面には起動画面の項で説明したメニュー一覧が表示されます。本体のFL ディスプレイには動作中の機能が表示されます。機能動作中の表示内容については、後述の機能詳細で記述します。

● Operation procedure of DIAG menu and SUB-MENU

There are 23 MENU items, each of which has some SUB-MENU items.

● ダイアグメニューとサブメニューの操作

ダイアグにはNo.1～23のメニューがあり、そのそれぞれにサブメニューがあります。

DIAG menu selection

Main unit: Select the menu using the PROGRAM knob (RX-V559/DSP-AX559) or ▷ (Forward) and ◁ (Reverse) keys of PROGRAM (HTR-5950).

ダイアグメニューの選択

本体キーでの操作：PROGRAMツマミで選択します。

SUB-MENU selection

Main unit: Select the sub-menu using ▷ (Forward) and ◁ (Reverse) keys of PRESET/TUNING.

サブメニューの選択

本体キーでの操作：PRESET/TUNING ▷ (順送り)、◁ (逆送り)キーで選択します。

Keys of main unit / 本体キー

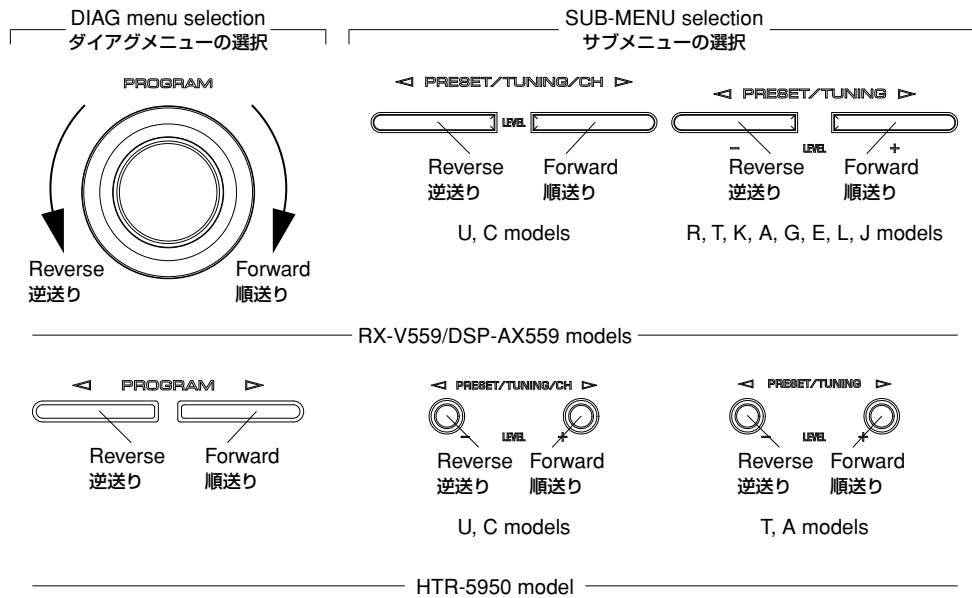

● Functions in DIAG mode

In addition to the DIAG menu items, functions as listed below are available.

- Input selection
- Center/Rear/Center/Sub-woofer level adjustment
- Speaker relay control of A and B
- Muting
- Power on/off
- Master volume
- * Functions related to the tuner and the set menu are not available.
- * It is possible to confirm Menu No.16 IF STATUS while keeping the signal process (operation status) of each DIAG menu by using the INPUT MODE key of the main unit.

● Initial settings used to start DIAG

The following settings are used when starting DIAG. When DIAG is canceled, these settings are restored to those before starting DIAG.

- Master volume: -20 dB
- Input: DVD (MULTI CH INPUT OFF)
- Effect level: 0 dB
- Audio mute: OFF
- Speaker relay of A and B: ON
- Speaker setting: LARGE / BASS OUT = SWFR
- DIAG menu: BYPASS (1. ANALOG BYPASS)

● ダイアグ中の機能

ダイアグメニューの他に、以下の機能が動作します。

- インプット切り換え
- センター、リア、リアセンター、サブウーファーレベル調整
- スピーカーリレーA/B
- ミューティング
- パワーオン/オフ
- マスターボリューム

※ チューナー関連、セットメニュー関連は機能しません。

※ 本体のINPUT MODEキーにより、各ダイアグメニューの信号処理(動作状態)を維持したままメニューNo.16 "IF STATUS"の確認ができます。

● ダイアグ開始時の初期設定

ダイアグ開始時に以下のような設定になります。ダイアグ解除時にはダイアグ開始前の状態に戻ります。

- マスターボリューム: -20 dB
- インプット: DVD (MULTI CH INPUT オフ)
- エフェクトレベル: 0 dB
- オーディオミュート: オフ
- スピーカーリレーA/B: ON
- スピーカー設定: LARGE / BASS OUT = SWFR
- ダイアグメニュー: BYPASS (1. ANALOG BYPASS)

RX-V559/HTR-5950/DSP-AX559

● Details of DIAG menu

● ダイアグメニュー詳細

1. BYPASS

Using the sub-menu, it is possible to select analog bypass output or DSP bypass output.

1. BYPASS

サブメニューによりANALOG BYPASS/DSP BYPASSが選択可能です。

ANALOG BYPASS

ANALOG BYPASS

1. ANALOG BYPAS

Reference data
 INPUT: DVD ANALOG
 SUBWOOFER OUTPUT: 50 Hz, Others: 1 kHz

Input level	Volume	SPEAKERS OUT				SUBWOOFER OUTPUT
		FRONT L/R	CENTER	SURROUND L/R	SURROUND BACK L/R	
Both ch, -20 dBm	+6.0 dB	+13.0 dBm	- ∞	- ∞	- ∞	- ∞

DSP BYPASS

DSP BYPASS

1. DSP BYPASS

Reference data
 INPUT: DVD ANALOG
 SUBWOOFER OUTPUT: 50 Hz, Others: 1 kHz

Input level	Volume	SPEAKERS OUT				SUBWOOFER OUTPUT
		FRONT L/R	CENTER	SURROUND L/R	SURROUND BACK L/R	
Both ch, -20 dBm	+6.0 dB	+13.5 dBm	- ∞	- ∞	- ∞	- ∞

ANALOG BYPASS

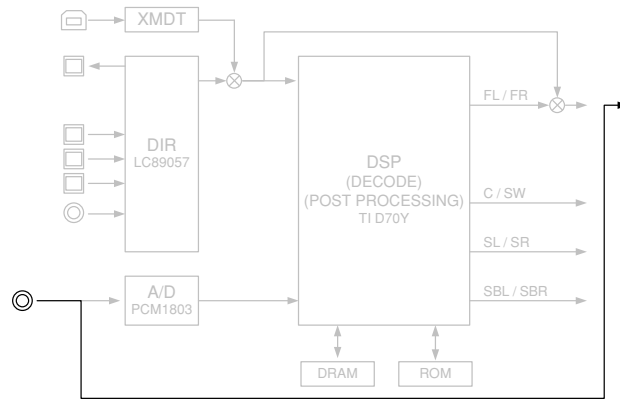

(Shaded items not used in this example)

DSP BYPASS

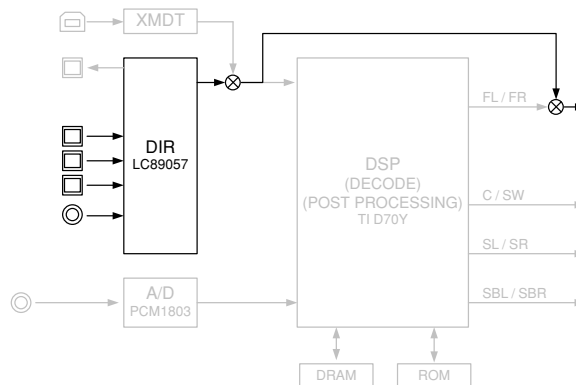

(Shaded items not used in this example)

RX-V559/HTR-5950/
 DSP-AX559

2. RAM THROUGH

Using the sub-menu, it is possible to select margin output or full-bit output.

RAM MARGIN

Following head margin is reserved.

FRONT	CENTER	SURROUND	SURROUND BACK	SUBWOOFER
+15.0 dB	+13.5 dB	+9.0 dB	+7.5 dB	+21.0 dB

2. RAM MARGIN

Reference data

INPUT: DVD ANALOG

SUBWOOFER OUTPUT: 50 Hz, Others: 1 kHz

Input level	Volume	SPEAKERS OUT				SUBWOOFER OUTPUT
		FRONT L/R	CENTER	SURROUND L/R	SURROUND BACK L/R	
Both ch, -20 dBm	+6.0 dB	+13.5 dBm	+13.5 dBm	+13.5 dBm	+13.5 dBm	+2.0 dBm

RAM FULL BIT

No head margin is reserved except SW.

FRONT	CENTER	SURROUND	SURROUND BACK	SUBWOOFER
0 dB	0 dB	0 dB	0 dB	+21.0 dB

2. RAM FULL BIT

Reference data

INPUT: DVD ANALOG

SUBWOOFER OUTPUT: 50 Hz, Others: 1 kHz

Input level	Volume	SPEAKERS OUT				SUBWOOFER OUTPUT
		FRONT L/R	CENTER	SURROUND L/R	SURROUND BACK L/R	
Both ch, -20 dBm	+6.0 dB	+13.5 dBm	+13.5 dBm	+13.5 dBm	+13.5 dBm	+2.0 dBm

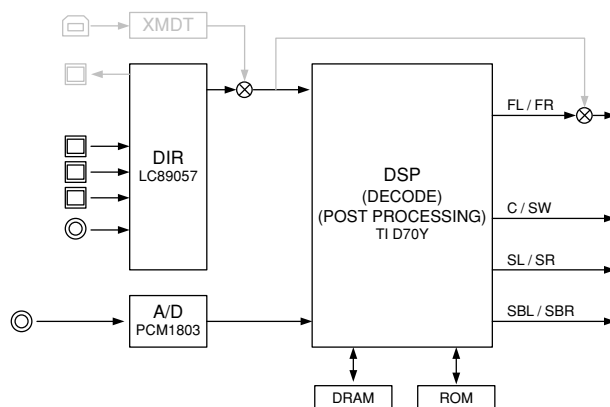

(Shaded items not used in this example)

When input source is stereo, signal is assigned as below.
2ch信号入力時、以下のように信号を振り分けて出力します。

- Front L → Center / Surround L / Surround Back L, R
- Front R → Surround R
- Front L +10 dB → SWFR

2. RAM THROUGH

サブメニューによりMARGIN/Full Bitが選択可能です。

RAM MARGIN

以下のヘッドマージンを取ります。

RAM FULL BIT

SW以外のヘッドマージンを取りません。

RX-V559/HTR-5950/DSP-AX559

3. PRO LOGIC

Dolby PRO LOGIC is applied to input stereo source.

3. PRO LOGIC

入力2ch信号にDolby PRO LOGIC処理を行います。

3. PRO LOGIC

Reference data

INPUT: DVD ANALOG

SUBWOOFER OUTPUT: 50 Hz, Others: 1 kHz

Input level	Volume	SPEAKERS OUT				SUBWOOFER OUTPUT
		FRONT L/R	CENTER	SURROUND L/R	SURROUND BACK L/R	
Each ch, -20 dBm	+6.0 dB	+13.5 dBm	- ∞	- ∞	- ∞	- ∞
Both ch, -20 dBm	+6.0 dB	-20.0 dBm	+16.5 dBm	- ∞	- ∞	- ∞

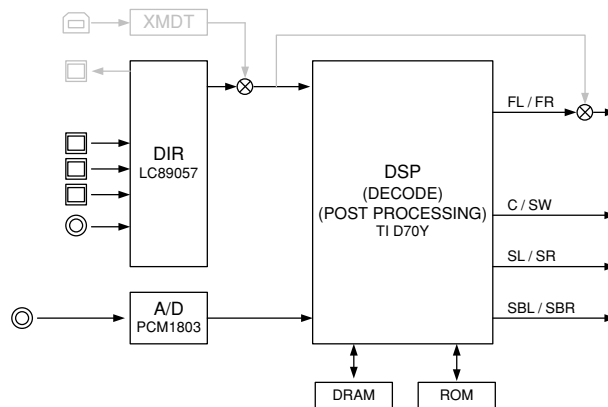

(Shaded items not used in this example)

4. SPEAKERS SET

The analog switch settings for each sub-menu are as shown in the table below.

4. SPEAKERS SET

各サブメニューにおけるアナログスイッチの設定は以下の通りです。

Sub-menu	FRONT L/R	CENTER	SUR. L/R	SUR. B L/R	LFE/BASS
1 FRNT: SML 0 dB	SMALL	LARGE	LARGE	LARGE	SWFR
2 CENTER: NONE	LARGE	NONE	LARGE	LARGE	SWFR
3 LFE/B: FRNT	LARGE	SMALL	SMALL	SMALL	FRONT
4 Pre Mix: 5ch	-	-	-	-	-
5 Front GAIN 1	-	-	-	-	-
6 Front GAIN 2	-	-	-	-	-
7 SURR B Check	-	-	-	-	-

- LARGE:** This mode is used with a speaker with high bass reproduction performance (a large unit). Full bandwidth signals are output.
- SMALL:** This mode is used with a speaker with low bass reproduction performance (a small unit). The signals of 80 Hz or less are mixed into the channel specified by LFE/BASS.
- NONE:** This mode is used with no center speaker. The center content is reduced by 3 dB and distributed to FRONT L/R.
- SWFR:** LFE of 5.1 ch signal or LFE/BASS lower than 90Hz is output through SUBWOOFER OUT.
- FRONT:** LFE of 5.1 ch signal or LFE/BASS lower than 90Hz is distributed to FRONT L/R.

- LARGE :** 低音再生能力の高い(ユニットの大きい)スピーカーを使用するモードです。全帯域が出力されます。
- SMALL :** 低音再生能力の低い(ユニットの小さい)スピーカーを使用するモードです。80 Hz以下がLFE/BASSで指定したチャンネルにミックスされます。
- NONE :** スピーカーを使用しないモードです。センター成分は-3 dBされて、FRONT L/R に振り分けられます。
- SWFR :** 5.1 ch信号のLFEまたは90Hz以下のLFE/BASSがSUBWOOFER OUTに出力されます。
- FRONT :** 5.1 ch信号のLFEまたは90Hz以下のLFE/BASSをFRONT L/Rに振り分けます。

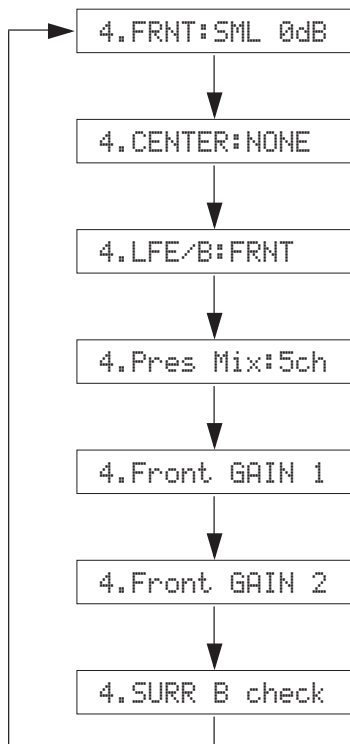

Reference data

INPUT: DVD ANALOG (Both ch)

SUBWOOFER OUTPUT: 50 Hz, Others: 1 kHz

	Sub-menu	Input level	Volume	SPEAKER OUT				SUBWOOFER OUTPUT
				FRONT L/R	CENTER	SURROUND L/R	SURROUND BACK L/R	
1	FRONT: SML 0dB	Both ch, -20 dBm	+6.0 dB	+13.5 dBm	+13.5 dBm	+13.5 dBm	+13.5 dBm	+5.5 dBm
2	CENTER: NONE	Both ch, -20 dBm	+6.0 dB	+10.5 dBm	- ∞	+13.5 dBm	+13.5 dBm	+2.0 dBm
3	LFE/B: FRNT (1 kHz)	Both ch, -20 dBm	+6.0 dB	- ∞	+13.5 dBm	+13.5 dBm	+13.5 dBm	- ∞
	LFE/B: FRNT (50 Hz)	Both ch, -20 dBm	+6.0 dB	+25.0 dBm	+13.5 dBm	+13.5 dBm	+13.5 dBm	- ∞
4	Pres Mix: 5ch	Both ch, -20 dBm	+6.0 dB	- ∞	+13.5 dBm	+18.5 dBm	- ∞	-0.5 dBm
5	Front Gain 1	Both ch, -20 dBm	+6.0 dB	+20.5 dBm	+13.5 dBm	+13.5 dBm	+13.5 dBm	+2.0 dBm
6	Front Gain 2	Both ch, -20 dBm	+6.0 dB	+20.5 dBm	+13.5 dBm	+13.5 dBm	+13.5 dBm	+2.0 dBm
7	SURR B check	Both ch, -20 dBm	+6.0 dB	- ∞	- ∞	- ∞	+13.5 dBm	- ∞

RX-V559/HTR-5950/DSP-AX559

5. XCH INPUT

The signal input through the multi ch input is output.
The speaker impedance can be selected.

XCH INPUT_6 (ohms)

5.XCH INPUT_6

Reference data

INPUT: MULTI CH INPUT

SUBWOOFER OUTPUT: 50 Hz, Others: 1 kHz

Input level	Volume	SPEAKERS OUT				SUBWOOFER OUTPUT
		FRONT L/R	CENTER	SURROUND L/R	SURROUND BACK L/R	
Both ch, -20 dBm	+6.0 dB	+13.5 dBm	+13.5 dBm	+13.5 dBm	- ∞	-10.0 dBm

5. XCH INPUT

マルチCH入力された信号が出力されます。
6オーム、8オームが選択されます。

XCH INPUT_6(ohms)

XCH INPUT_8 (ohms)

5.XCH INPUT_8

Reference data

INPUT: MULTI CH INPUT

SUBWOOFER OUTPUT: 50 Hz, Others: 1 kHz

Input level	Volume	SPEAKERS OUT				SUBWOOFER OUTPUT
		FRONT L/R	CENTER	SURROUND L/R	SURROUND BACK L/R	
Both ch, -20 dBm	+6.0 dB	+13.5 dBm	+13.5 dBm	+13.5 dBm	- ∞	-10.0 dBm

XCH INPUT_8(ohms)

LIMIT SET

Not applied to these models.

XXXXXXXXXXXXX_

LIMIT SET

このモデルには適用されません。

6. MIC CHECK

Not applied to these models.

6.MIC CHK --dB

6. MIC CHECK

このモデルには適用されません。

7. DISPLAY CHECK

This program is used to check the FL display section and video control section. The display condition varies as shown below according to the sub-menu operation. The signal route is STRAIGHT.

Checking FL display section / FL表示部のチェック

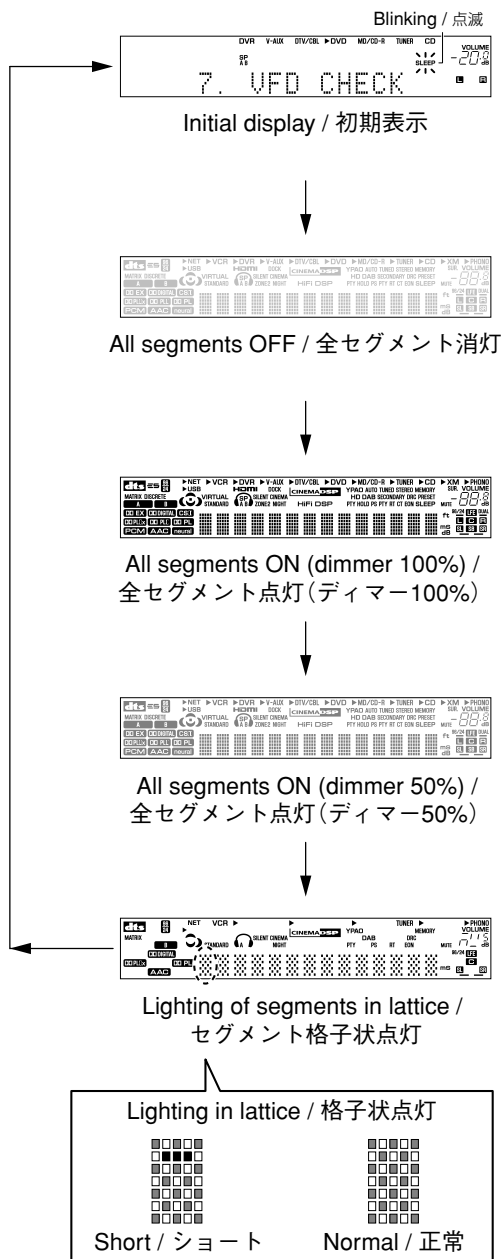

Segment conditions of the FL driver and the FL tube are checked by turning ON and OFF all segments. Next, the operation of the FL driver is checked by using the dimmer control. Then a short between segments next to each other is checked by turning ON and OFF all segments alternately (in lattice). (In the above example, the segments in the second row from the top are shorted.)

7. DISPLAY CHECK

FL表示部と映像制御部のチェックプログラムです。サブメニュー操作により、表示状態が以下のように変わります。信号処理はSTRAIGHTです。

Checking OSD section (Monitor Out) / 映像制御部のチェック (モニターアウト)

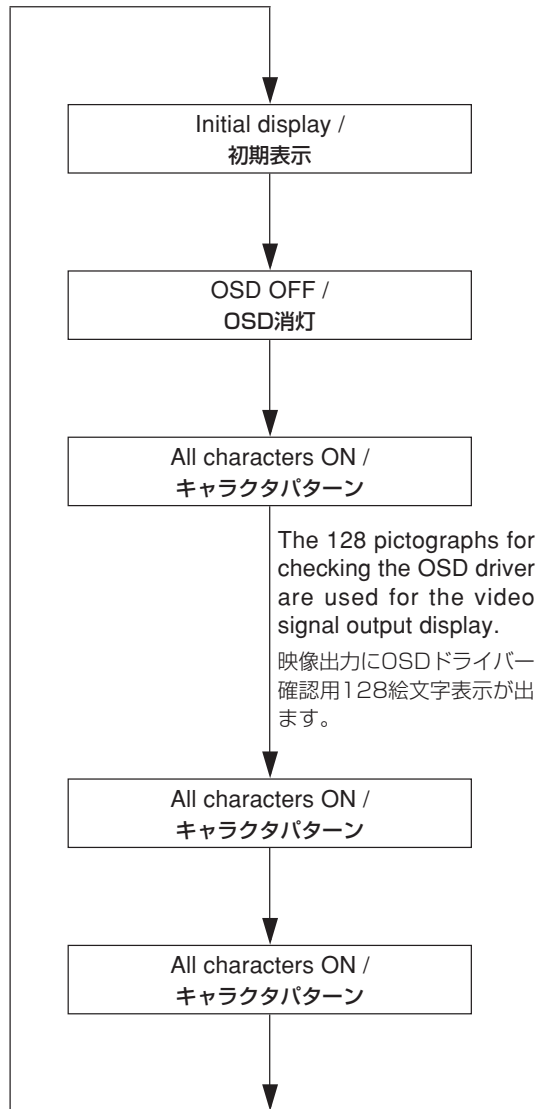

全セグメント消灯・全セグメント点灯によりFLドライバー、FL管のセグメントの不良を確認します。次に、ディマーコントロールによってFLドライバーの動作チェックを行います。さらに全セグメントを交互(格子状)に点灯/消灯することで、隣り合うセグメントのショートをチェックします。(上図の例では、上から2行目のセグメントがショートしていません。)

RX-V559/HTR-5950/DSP-AX559

8. MANUAL TEST

The test noise based THX is output to the channel specified by the sub-menu from the DSP.
The noise frequency for LFE is 35 to 250 Hz. Other than that, the center frequency is 800 Hz.

8. MANUAL TEST

DSPからサブメニューで指定したチャンネルへTHX準拠のテストノイズを出力します。
LFE用のノイズ周波数は35~250 Hz、それ以外は中心周波数800 Hzとなります。

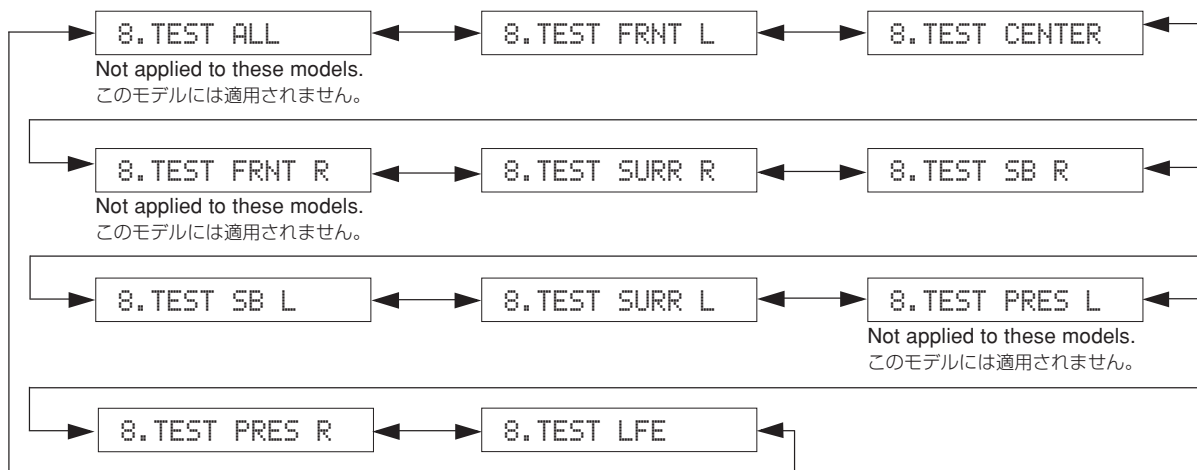

9. FACTORY PRESET

This menu is used to reserve/inhibit initialization of the backup RAM (Parameters and set menu contents, etc. of the sound field program).

9. FACTORY PRESET

バックアップ用RAM (音場プログラムのパラメーターやセットメニュー内容など)の初期化を予約/禁止します。

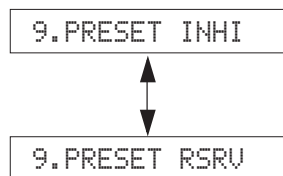

PRESET INHIBIT (Initialization inhibited) / **PRESET INHIBIT** (初期化禁止)
RAM initialization is not executed. Select this sub-menu to protect the values set by the user.
Note: The protection history will not be erased using PRESET INHIBIT.
RAMの初期化は行われません。ユーザーの設定値を保護するときは、こちらを選択してください。

PRESET RESERVED (Initialization reserved) / **PRESET RESERVED** (初期化予約)
Initialization of the back-up RAM is reserved. (Actually, initialization is executed the next time that the power is turned on.) Select this sub-menu to reset to the original factory settings or to reset the RAM. Use PRESET RESERVED to erase the protection history.
バックアップRAMの初期化が予約されます。(実際に初期化されるのは、次回の電源投入時です。) 工場出荷時やRAMをリセットしたいときは、こちらを選択してください。

CAUTION: Before setting to the PRESET RESERVED, write down the existing preset memory. Content of the Tuner in a table as shown below. (This is because setting to the PRESET RESERVED will cause ALL user memory contents to be erased.)

注意： PRESET RESERVEDを選んで初期化をする前に、チューナーのユーザーメモリー内容を下表に書き写してください。(初期化をすると、ユーザーメモリーの内容は消えてしまいます。)

Preset group	P1	P2	P3	P4	P5	P6	P7	P8
A								
B								
C								
D								
E								

• PRESET STATIONS / プリセット局

STATION		FM FACTORY PRESET DATA (MHz)			
PAGE	NO.	U, C	R, T, K, A, G, E, L	J	
A/C/E	1	87.5	87.50	76.0	
	2	90.1	90.10	83.0	
	3	95.1	95.10	84.0	
	4	98.1	98.10	86.0	
	5	107.9	108.00	90.0	
	6	88.1	88.10	78.0	
	7	106.1	106.10	88.0	
	8	107.9	108.00	82.1	

STATION		AM FACTORY PRESET DATA (kHz)			
PAGE	NO.	U, C, R, T, K	A, G, E, L	J	
B/D	1	630	630	630	
	2	1080	1080	1080	
	3	1440	1440	1440	
	4	530	531	531	
	5	1710	1611	1611	
	6	900	900	900	
	7	1350	1350	1350	
	8	1400	1404	1404	

10. AD DATA CHECK

This menu is used to display the A/D conversion value of the Microprocessor which detects panel keys of the main unit and protection functions in using the sub-menu. During audio signal processing, the condition before execution is maintained.

When K0/K1 menu is selected, keys become non-operable due to detection of the values of all keys. However, it is possible to advance to the next sub-menu by turning the VOLUME of the main unit. When using this function, note that turning the VOLUME more than 1 click would cause the volume value to change.

* The figures in the diagram are given as reference only.

PS1/PS2 (Power supply voltage protection detection)

Power supply voltage protection value (Normal value: PS1: 17 to 66, PS2: 36 to 53)

PS1: Detects +5S and +5.3X (U, C models).

PS2: Detects ±12V, ±5V, +5D, +3.3D and +5i.

* If PS is out of the normal value range, the protection function works to turn off the power.

(Reference voltage: 5 V=100 %)

PS1:039 2:044

DC/TH (protection detection/temperature detection)

DC: DC detect protection value (Normal value: 5 to 36)

* If DC is out of the normal value range, the protection function works to turn off the power.

(Reference voltage: 5 V=100 %)

TH: Detects the temperature of the heat sink.

Temperature detected value

(Normal value: 9 to 177) U, C, T, K, A, G, E, J models

(Normal value: 9 to 167) R, L models

(Reference voltage: 5 V=255)

DC:007 TH098

10. AD DATA CHECK

本機パネルキー、プロテクションなどを検出しているMicroprocessorのA/D変換の値を、サブメニューで表示します。オーディオ信号処理は実行前の状態を維持します。

K0/K1のメニューにすると、全キーの値を検出するためキー操作はできなくなりますが、本機のVOLUMEを回すことにより、次のサブメニューに進めることができます。このとき1クリック以上回すと、ボリューム値が変化するので注意してください。

※ 図中の数値は参考例です。

PS1/PS2 (電源電圧プロテクションの検出)

プロテクションの値(正常値 PS1: 17~66、PS2: 36~53)

PS1: +5Sを検出しています。

PS2: ±12V、±5V、+5D、+3.3D、+5iを検出しています。

※ PSは正常値を外れるとプロテクションが働き、電源オフされます。

(基準電圧: 5V=100%)

DC/TH (プロテクションの検出/温度検出)

DC: DC検出プロテクションの値(正常値5~36)

※ DCは正常値を外れるとプロテクションが働き、電源オフされます。

(基準電圧: 5V=100%)

TH: ヒートシンクの温度を検出しています。

温度検出値

(正常値: 9~177)

(基準電圧: 5V=255)

RX-V559/HTR-5950/
DSP-AX559

IMP SW/POWER LIMIT (impedance/power limiter detection)

IMP: Not applied to these models.

PL: Power limiter detection value

The voltage value of pin No. 123 of IC2 is displayed, using 5V/256 as standard.

The port (No. 6) output is controlled by using the input voltage value of pin No. 123 of IC2.

IMP SW/POWER LIMIT (インピーダンス/パワーリミッターの検出)

IMP: このモデルには適用されません。

PL: パワーリミッター検出の値

IC2 123ピンの入力電圧値を5V/256を基準にして表示します。IC2 123ピンの入力電圧値により、ポート(6ピン)を制御します。

IMP:8 PL:245

PANEL KEY (K0/K1)

(Panel key of main unit) [Remote control code: -]

A/D of the key fails to function properly when the standard value is deviated by ± 8 . In this case, check the constant of partial pressure resistor, solder condition, etc. Refer to table.

(Reference voltage: 5 V=100 %)

PANEL KEY (K0/K1)

(本機パネルキー)

キーのA/Dは基準値から ± 8 を外れると、正常な動きをしません。下表をご覧ください。各キーの分圧抵抗の定数、ハンダ不良等の確認をしてください。

(基準電圧: 5V=100%)

K0:100 K1:100

RX-V559/DSP-AX559

Display (%)	K0	K1
0 - 6	MAIN ZONE ON/OFF	ZONE ON/OFF
7 - 13	—	—
14 - 21	—	—
22 - 31	—	ZONE CONTROL
32 - 41	INPUT MODE	MULTI CH INPUT
42 - 53	STRAIGHT	FM/AM
54 - 63	TONE CONTROL	A/B/C/D/E
64 - 72	PRESET/TUNING	< PRESET
73 - 80	SPEAKERS B	PRESET >
81 - 88	SPEAKERS A	MEMORY
89 - 95	—	TUNING MODE
96 - 100	KEY OFF	KEY OFF

HTR-5950

Display (%)	K0	K1
0 - 6	< PROGRAM	—
7 - 13	PROGRAM >	—
14 - 21	BASS/TREBLE -	—
22 - 31	BASS/TREBLE +	—
32 - 41	INPUT MODE	MULTI CH INPUT
42 - 53	STRAIGHT	FM/AM
54 - 63	TONE CONTROL	A/B/C/D/E
64 - 72	PRESET/TUNING	< PRESET
73 - 80	SPEAKERS B	PRESET >
81 - 88	SPEAKERS A	MEMORY
89 - 95	—	TUNING MODE
96 - 100	KEY OFF	KEY OFF

11. VIDEO

The image signal is converted and output as follows.

I2C

Perform the read/write check between the microprocessor and ADV7180 (IC411) as well as ADV7172 (IC412).

11. VIDEO

映像信号が以下のように変換され、出力されます。

I2C

マイコンとADV7180(IC411)、およびADV7172(IC412)間のリード/ライトのチェックを行います。

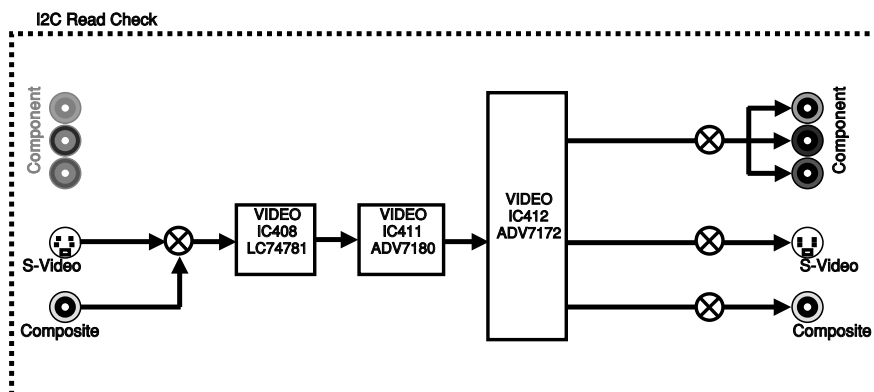
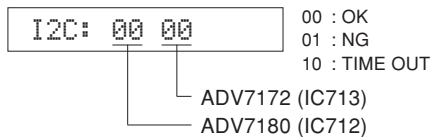

DIGITAL THR CVBS

DIGITAL THR CVBS

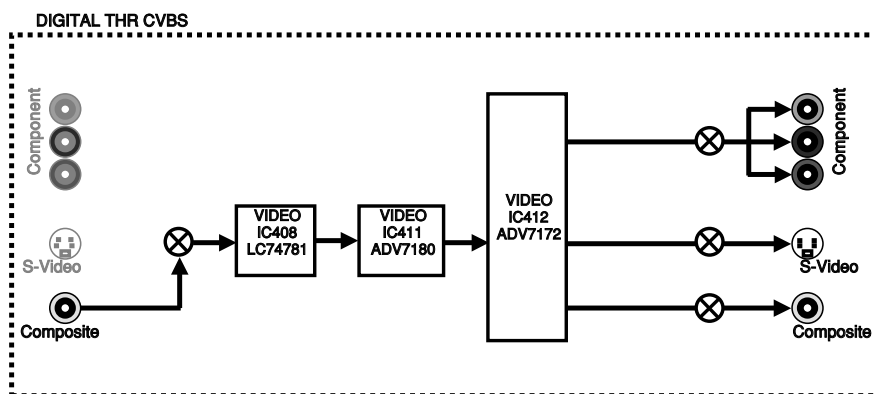
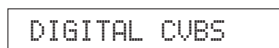

DIGITAL THR Y/C

DIGITAL THR Y/C

DIGITAL Y/C

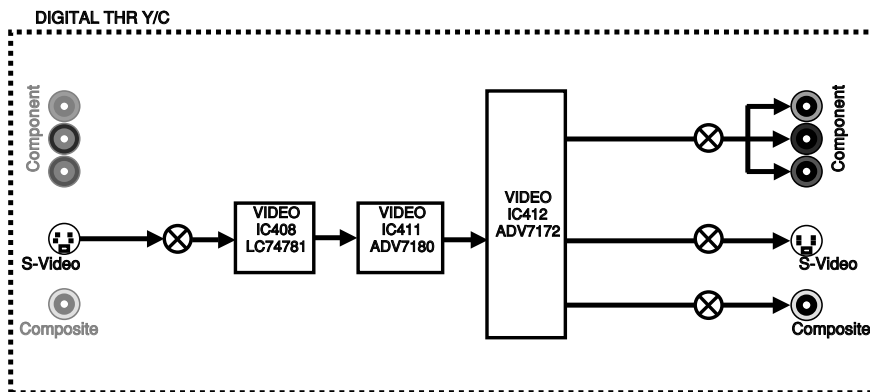

ANALOG BYPASS

ANALOG BYPASS

ANALOG BYPASS

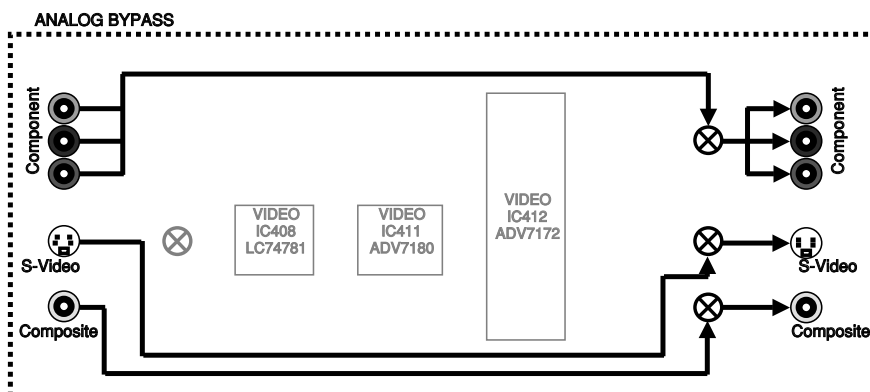

TEST PATTERN

TEST PATTERN

TEST PATTERN

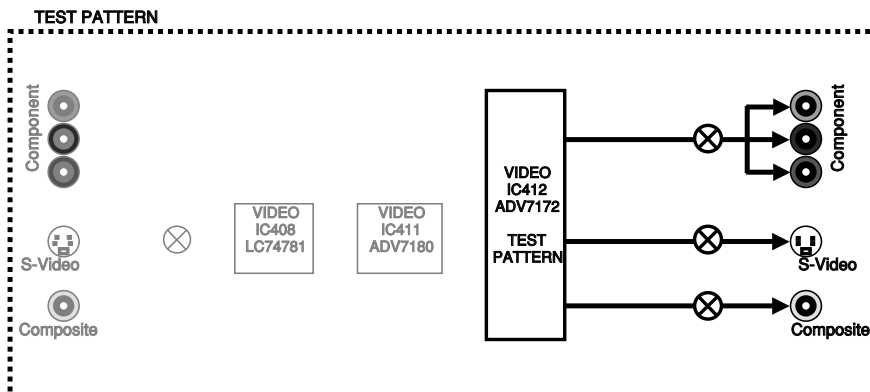

IC713 TEST Pattern (480i/576i)

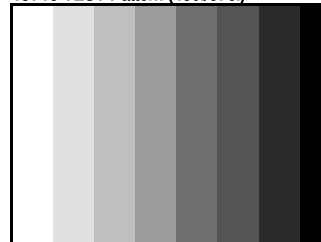

RX-V559/HTR-5950/
DSP-AX559

LOOP BACK CVBS

Not applied to these models.

LOOP BACK CVBS

このモデルには適用されません。

LPBK CVBS OK

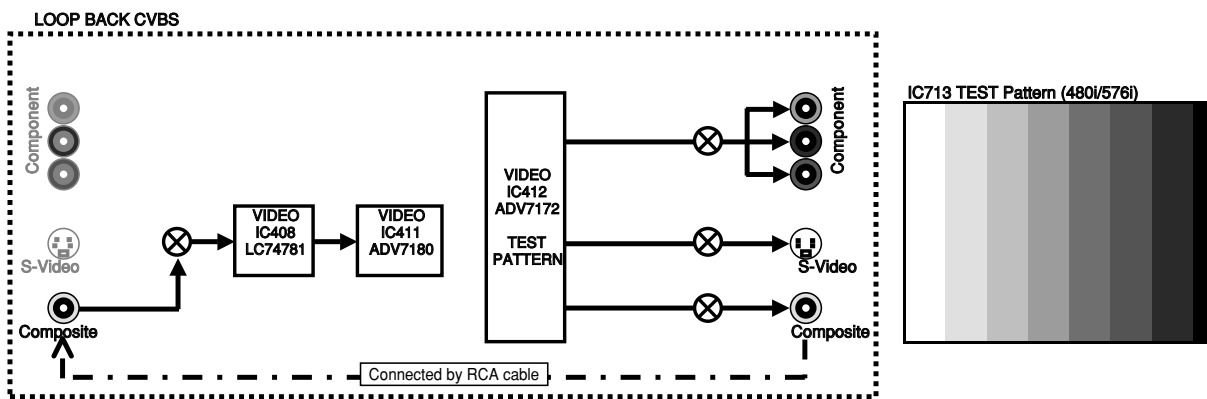

LOOP BACK Y/C

Not applied to these models.

LOOP BACK Y/C

このモデルには適用されません。

LPBK Y/C OK

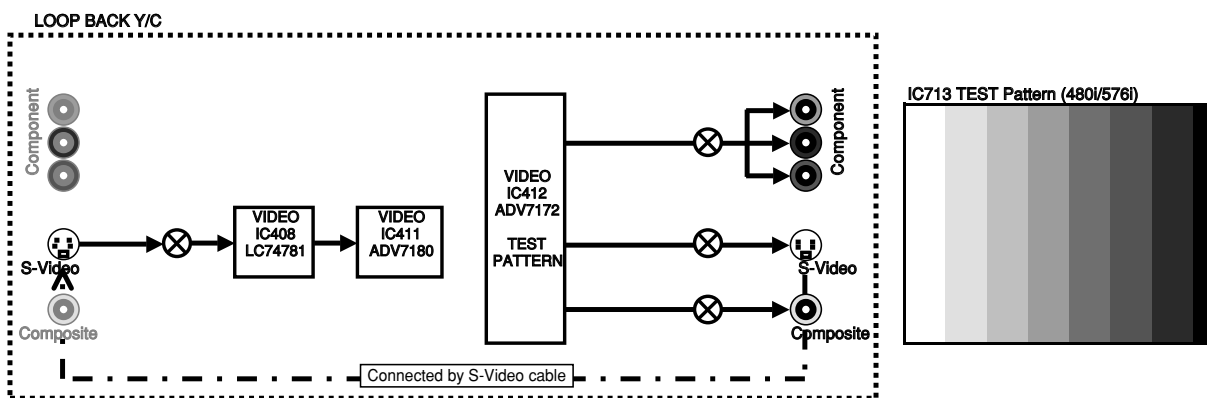

RX-V559/HTR-5950/
DSP-AX559

12. XM STATUS (U, C models)

Perform the output check of XM Radio Antenna connected to the XM terminal.

1k -1dB/44.1k

The test tone (1kHz, -1dB/44.1kHz) is output.

1k - 1dB/44

1k -61dB/44.1k

The test tone (1kHz, -61dB/44.1kHz) is output.

1k -61dB/44

Mute /44.1k

Nothing is output.

Mute /44

XM Tone/44.1k

The XM tone (44.1kHz) is output.

XM Tone/44

ISO Tone/44.1k

The ISO tone (44.1kHz) is output.

ISO Tone/44

1k -1dB/32k

The test tone (1kHz, -1dB/32kHz) is output.

1k - 1dB/32

1k -61dB/32k

The test tone (1kHz, -61dB/32kHz) is output.

1k -61dB/32

12. XM STATUS(U, C models)

XM端子に接続された、XM Radio Antennaの出力チェックを行います。

1k -1dB/44.1k

テストトーン(1kHz、-1dB/44.1kHz)を出力します。

1k -61dB/44.1k

テストトーン(1kHz、-61dB/44.1kHz)を出力します。

Mute /44.1k

何も出力されません。

XM Tone/44.1k

XMトーン(44.1kHz)を出力します。

ISO Tone/44.1k

ISOトーン(44.1kHz)を出力します。

1k -1dB/32k

テストトーン(1kHz、-1dB/32kHz)を出力します。

1k -61dB/32k

テストトーン(1kHz、-61dB/32kHz)を出力します。

Mute /32k

Nothing is output.

Mute /32

Mute /32k

何も出力されません。

XM Tone/32k

The XM tone (32kHz) is output.

XM Tone/32

XM Tone/32k

XMトーン(32kHz)を出力します。

ISO Tone/32k

The ISO tone (32kHz) is output.

ISO Tone/32

ISO Tone/32k

ISOトーン(32kHz)を出力します。

XM/DT Bus Power: OFF

The power of XM module is turned off.

Bus Power:OFF

XM/DT Bus Power: OFF

XMモジュールの電源をOFFします。

13. iPod

This menu is used to test the DOCK connector without the iPod itself. After turning off the power, short between pins No. 14 (TX) and No. 18 (RX), between pins No. 1 (PWR) and No. 17 (ACCPow) and between pins No. 4 (iPDET) and No. 8 (DGND). (Make sure that the power is turned off when shorting pins.)

Start the DIAG function and select the menu.

The check result is displayed according to the following display specifications.

Note) Be sure to return the shorted locations to their original state.

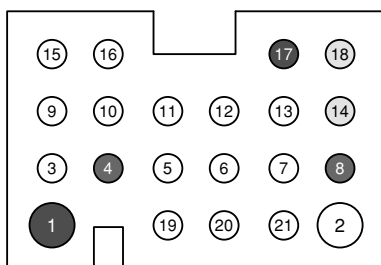

DOCK

13. iPod

iPod本体無しで、DOCKコネクタの検査を行うメニューです。パワーオフ状態にしてから、DOCKコネクタの14ピン(TX)と18ピン(RX)、1ピン(PWR)と17ピン(ACCPow)、4ピン(iPDET)と8ピン(DGND)をショートさせます。(ショートさせる時は、必ず電源を切ってください。)

ダイグを起動してメニューを選択します。

下記表示仕様に従って、チェック結果が表示されます。

注) ショート箇所は、必ず元に戻してください。

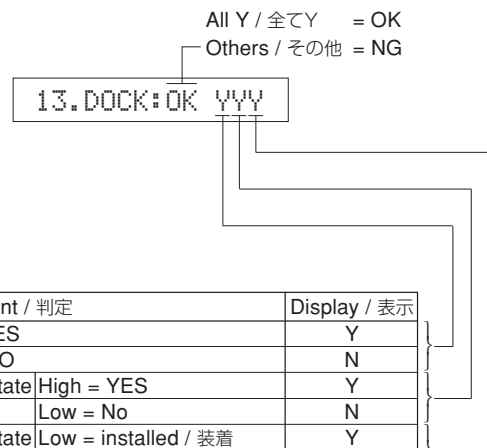

Check item / チェック項目	Judgment / 判定	Display / 表示
Is UART loop pack check result OK? / UARTループバックチェック結果はOK?	YES	Y
	NO	N
Is detect function of iPod Accessory Power OK? / iPod Accessory Powerの検出機能はOK?	IC2 (DSP P.C.B.) pin No. 45 state High = YES	Y
	IC2 (DSP P.C.B.) 45pinの状態 Low = No	N
Is detect function of iPod installation to DOCK OK? / DOCKへのiPod装着の検出機能はOK?	IC2 (DSP P.C.B.) pin No. 44 state Low = installed / 装着	Y
	IC2 (DSP P.C.B.) 44pinの状態 High = not installed / 非装着	N

16. IF STATUS (Input function status)

Using the sub-menu, the status data is displayed one after another in the hexadecimal notation.

During signal processing, the status before execution of this menu is maintained.

* Numeric values in the figure example are for reference.

DST: DSP status

16. IF STATUS

サブメニュー操作により、以下のステータス情報を順次16進数で表示します。信号処理は、本メニュー実行前の状態を維持します。

※図中の数値は参考例です。

DST : DSPステータス

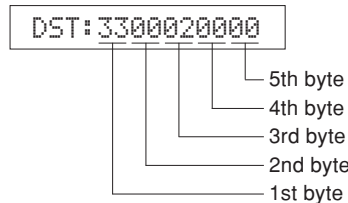

<1st byte> Digital input/output setting value
Upper 4 bits: REC OUT selected /
lower 4 bits: INPUT selected

<第1バイト> デジタル入出力設定値
上位4 bit REC OUT選択 /
下位4 bit INPUT選択

Value	Choice	Preset name
0	NONE	-
1	OPT FRONT	-
2	OPT 1	MD/CD-R
3	OPT 2	DVD
4	OPT 3	DTV/CBL
8	COAX 1	CD
9	COAX 2	-

<2nd byte> / <第2バイト>
Fs information of reproduction signal /
再生信号のFs情報

Display	Fs (kHz)
00	Analog
01	32 kHz
02	44.1 kHz
03	48 kHz
04	64 kHz
05	88.2 kHz
06	96 kHz
07	128 kHz
08	176.4 kHz
09	192 kHz
0A	Unknown NRM
0B	Unknown DBL
0C	Unknown QUAD
0D	Unknown
0E	Undefined

<3rd byte> / <第3バイト>
Audio code mode information of
reproduction signal /
再生信号のオーディオコードモード情報

Display	Audio code
00	1+1
01	1/0
02	2/0
03	3/0
04	2/1
05	3/1
06	2/2
07	3/2
08	2/3
09	3/3
0A	3/4
0B	over 6.1
0C	Milti-Mono
0D	Milti-PCE
0E	Unknown
0F	Undefined

<4th byte> / <第4バイト>
Format information of reproduction signal /
再生信号のフォーマット情報

Display	Signal format
00	Analog
01	Err
10	PCM Audio
20	Digital Data
21	IEC1937
22	None PCM
23	Unknown
50	dts
51	dts-CD
52	dts 96/24
54	dts-ES (Matrix)
58	dts-ES (Discrete)
5C	dts-ES (Both)
60	AAC
C0	Dolby Digital
C1	Dolby Digital Karaoke
C4	Dolby Digital EX
FF	Undefined

<5th byte> / <第5バイト>
 Signal processing status information /
 信号処理ステータス情報

bit	Fs (kHz)
bit 7	Digital mute
bit 6	—
bit 5	6.1 (7.1) processing
bit 4	Analog mute
bit 3	—
bit 2	PCM through
bit 1	—
bit 0	dts analog mute

DMD: Decoder mode information
 Not applied to these models.

DMD: デコーダー情報
 このモデルには適用されません。

```
DMD: 03C00000
```

DIF: DIR information
 Not applied to these models.

DIF: DIR情報
 このモデルには適用されません。

```
DIF: 0001000600
```

PC: Preamble C information
 Not applied to these models.

PC: Preamble C情報
 このモデルには適用されません。

```
PC : 0000
```

CS1, 2: Channel status information
 Not applied to these models.

CS1, 2: チャンネルステータス情報
 このモデルには適用されません。

```
CS1: 000000000000 ————— CS2: 00
```

DEI: Decoder information
 Not applied to these models.

DEI: デコーダー情報
 このモデルには適用されません。

```
DEI: 0303000600
```

BS1-8: Bit stream information
 Not applied to these models.

BS1-8: ビットストリーム情報
 このモデルには適用されません。

```
BS1: 000000000000 ————— BS8: 00
```

MTT: Mute Trigger
 Not applied to these models.

MTT: Mute Trigger
 このモデルには適用されません。

```
MTT: 0018001820
```

RX-V559/HTR-5950/
DSP-AX559

DGI: Digital information
Not applied to these models.

DGI: DIGITAL系情報
このモデルには適用されません。

DGI:EE6464F95E

17. DSP BUS CHECK

This menu is used to self-diagnose whether or not the bus connection for the TI (DA70Y) and the external ROM/RAM is made properly.
When no error is detected, "NoEr" appears on display.

17. DSP BUS CHECK

TI(DA70Y)と外付けROM/RAMとのバス接続の正否を自己診断します。
エラーが検出されなかった場合は、"NoEr"と表示されます。

TI BUS:NoEr

No error detected.
不良検出なし

or

TI BUS:Boot

When this indication is displayed with in seconds or displayed alternately "NoEr" and "Boot", it is highly possible that there are errors.
数秒間この状態、またはNoErと交互に表示される場合、異常が発生している可能性があります。



RDS IC:OK

or

RDS IC:NG

No applied to these models.
このモデルは適用されません。

18. SWFR CUT OFF

Not applied to these models.

18. SWFR CUT OFF

このモデルには適用されません。

18.LFE LPF 200



18.LFE HPF THR

19. PROTECTION SETTING

Not applied to these models.

19. PROTECTION SETTING

このモデルには適用されません。

PS_Lo: 0043



PL_6_N_H:0154

20. PROTECTION HISTORY

Four protection histories are display.

20. PROTECTION HISTORY

過去のプロテクション履歴を4つまで表示します。

20-1:NoPRT



20-4:NoPRT

RX-V559/HTR-5950/
DSP-AX559

21. SOFT SW

Note) Changing the function setting may hinder the proper operation.

This menu is used to switch the function settings on P.C.B. through the software so as to activate the product. The protection function follows the P.C.B. settings. When connected to AC or in the maker preset state, the unit is initialized to the P.C. B. setting. Display of each function after initialization varies depending on settings on P.C.B. The operation mode can be changed by selecting the sub-menu and then using the STRAIGHT key.

SW MODE: PCB, MODEL or FNC can be selected.

21.SW :PCB

MODEL SETTING: 759SE, V659, H5960, V559, H5950, V459 or H5935 can be selected. (SW MODE: Selectable when MODEL has been selected.)

21.MODEL:V559

DESTINATION: J, U, C, R, T, K, A, B, G (E) or L can be selected. (SW MODE: Selectable when MODEL has been selected.)

21.DEST :G

TUNER DESTINATION: J, UC, ABG or RL can be selected. (SW MODE: Selectable when FNC has been selected.)

21.TuDst:ABG

TUNER TYPE: NRM, RDS or XM can be selected. (SW MODE: Selectable when FNC has been selected.)

21.TuDyp:RDS

VIDEO FORMAT: NTSC or PAL can be selected. (SW MODE: Selectable when FNC has been selected.)

21.VIDEO:PAL

21. SOFT SW

注) 機能設定を変更した場合、正常に動作しないことがあります。

P.C.B.上の機能設定をソフト的に切り替えて、製品を動作させる機能です。プロテクション機能は、P.C.B.の設定にしがいます。AC接続またはメーカープリセットで、P.C.B.の設定に初期化されます。初期化後の各機能の表示は、P.C.B.上の設定によります。操作は、サブメニューを選んだ後、STRAIGHTキーで切り替えます。

SW MODE : PCB、MODELまたはFNCを選択できます。

MODEL SETTING : 759SE、V659、H5960、V559、H5950、V459、H5935のいずれかを選択できます。(SW MODE : MODEL時選択できます。)

DESTINATION : J、U、C、R、T、K、A、B、G(E)、Lのいずれかを選択できます。(SW MODE : MODEL時選択できます。)

TUNER DESTINATION : J、UC、ABG、RLのいずれかを選択できます。(SW MODE : FNC時選択できます。)

TUNER TYPE : NRM、RDS、XMのいずれかを選択できます。(SW MODE : FNC時選択できます。)

VIDEO FORMAT : NTSCまたはPALを選択できます。(SW MODE : FNC時選択できます。)

ZONE2: NOT or EXIST can be selected. (SW MODE: Selectable when FNC has been selected.)

ZONE2 : NOTまたはEXISTを選択できます。(SW MODE : FNC時選択できます。)

21.ZONE2:EXIST

AAC: NOT or EXIST can be selected. (SW MODE: Selectable when FNC has been selected.)

AAC : NOTまたはEXISTを選択できます。(SW MODE : FNC時選択できます。)

21.AAC :NOT

TUNER: NOT or EXIST can be selected. (SW MODE: Selectable when FNC has been selected.)

TUNER : NOTまたはEXISTを選択できます。(SW MODE : FNC時選択できます。)

21.TUNER:EXIST

ZONE2 AMP: NOT or EXIST can be selected. (SW MODE: Selectable when FNC has been selected.)

ZONE2 AMP : NOTまたはEXISTを選択できます。(SW MODE : FNC時選択できます。)

21.Z2AMP:NOT

OSD: NOT or EXIST can be selected. (SW MODE: Selectable when FNC has been selected.)

OSD : NOTまたはEXISTを選択できます。(SW MODE : FNC時選択できます。)

21.OSD :EXIST

YPAO: NOT or EXIST can be selected. (SW MODE: Selectable when FNC has been selected.)

YPAO : NOTまたはEXISTを選択できます。(SW MODE : FNC時選択できます。)

21.YPAO :NOT

22. SOFTWARE VERSION

The version, checksum and the port specified by the microprocessor are displayed. The signal is processed using EFFECT OFF. The checksum is obtained by adding the data at every 16 bits for each program area and expressing the result as a 4-figure hexadecimal data.

* Numeric values in the figure example are for reference.

22. SOFTWARE VERSION

ソフトウェアのバージョン、チェックサム、マイコンの指定ポートを表示します。
信号はエフェクトOFFです。チェックサムは、プログラムエリア別にデータを16ビットごとに加算していき、4桁の16進データで現したものです。

※図中の数値は参考例です。

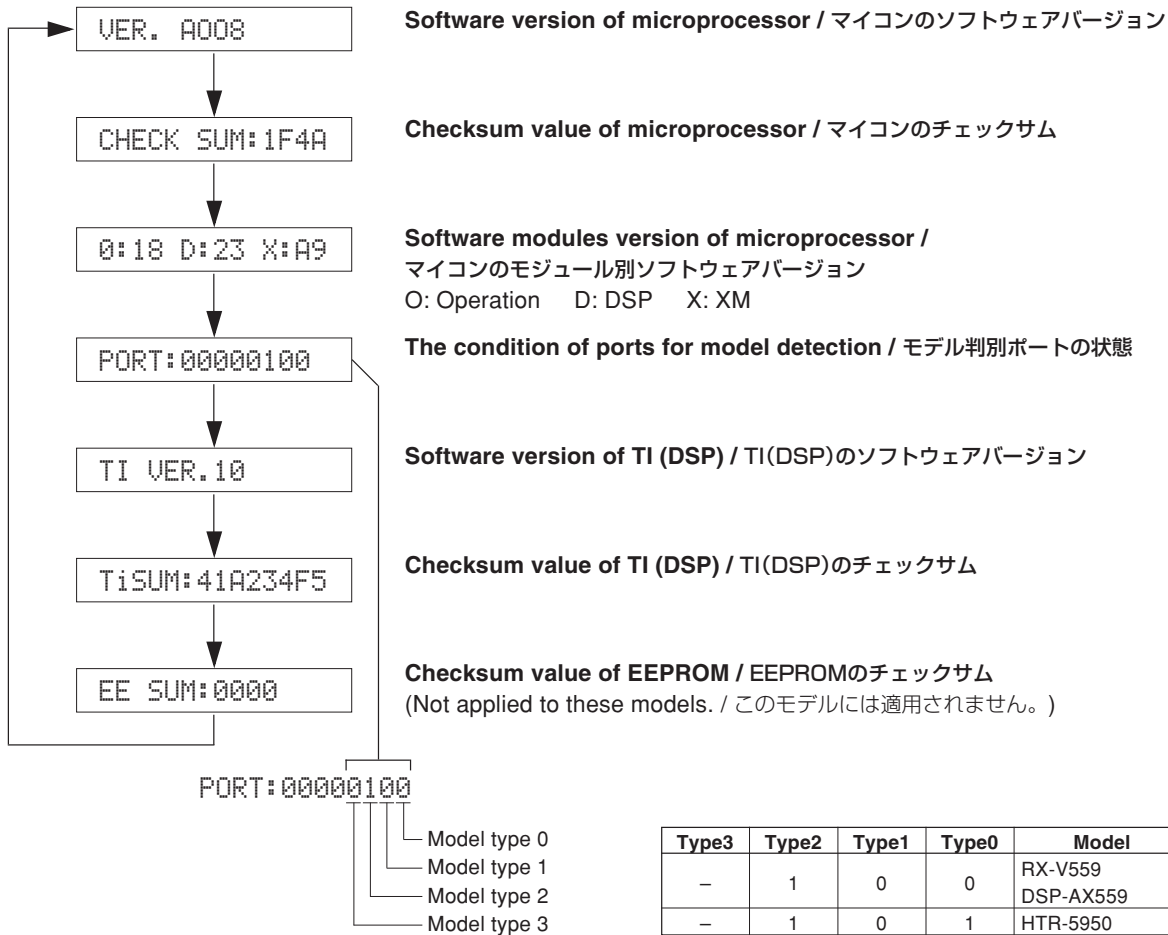

23. TI (DSP) BOOT

The rewriting mode of TI (DSP) software.
(Not applied to these models.)

23. TI(DSP)BOOT

TI(DSP)のソフトウェア書き換えモードです。
(このモデルには適用されません。)

23.TI BOOT ?

■ AMP ADJUSTMENT / アンプ部調整

Confirmation of Idling Current of MAIN (1) P. C. B.

- Right after power is turned on, confirm that each measured voltage across the terminals of R1149 (FRONT Lch), R1150 (FRONT Rch), R1153 (CENTER), R1154 (SURROUND Lch), R1152 (SURROUND Rch), R1151 (SURROUND BACK) is between 0.1 mV and 10.0 mV.
- If it exceeds 10.0 mV, open (cutoff) R1104 (FRONT Lch), R1106 (FRONT Rch), R1112 (CENTER), R1114 (SURROUND Lch), R1110 (SURROUND Rch), R1108 (SURROUND BACK) and reconfirm the voltage.

Attention

If the measured voltage exceeds 10.0 mV. after an amplifier repair, first check for a defective component before cutting the bias resistor.

- Confirm that the voltage is 0.2 mV ~ 15.0 mV. after 60 minutes.

メイン(1)基板のアイドル電流の確認

- 電源投入直後、R1149(FRONT Lch)、R1150(FRONT Rch)、R1153(CENTER)、R1154(SURROUND Lch)、R1152(SURROUND Rch)、R1151(SURROUND BACK)の端子間電圧を測定し、0.1 mVから10.0 mVの間であることを確認してください。

- 電圧が10 mVを超えている場合は、R1104(FRONT Lch)、R1106(FRONT Rch)、R1112(CENTER)、R1114(SURROUND Lch)、R1110(SURROUND Rch)、R1108(SURROUND BACK)をカットし、電圧を再確認してください。

注意

パワーアンプ修理後に10.0 mV.を超えている場合は、抵抗をカットする前に故障箇所を調べてください。

- 60分後、電圧が0.2 mV~15.0 mV.であることを確認してください。

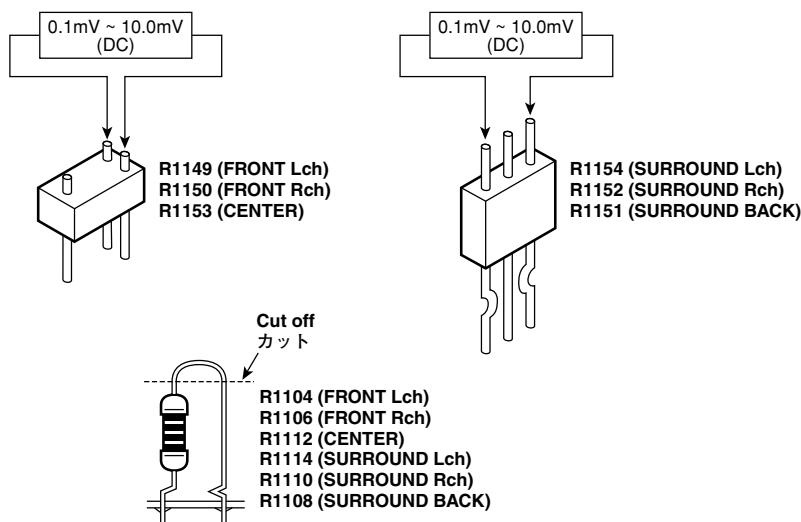

RX-V559/DSP-AX559

■ DISPLAY DATA

● V3000 : HNA-17MM03T (WG474000)

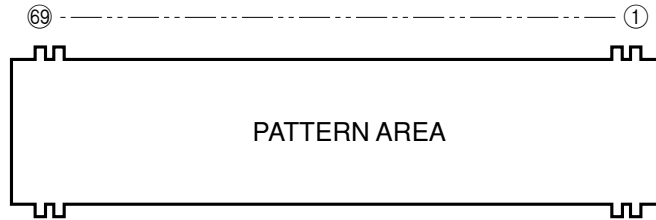

● PIN CONNECTION

Pin No.	69	68	67	66	65	64	63	62	61	60	59	58	57	56	55	54	53	52	51	50	49	48	47	46	45	44	43	42	41	40	39	38	37	36	35
Connection	F2	F2	NP	NP	P1	P2	P3	P4	P5	P6	P7	P8	P9	P10	P11	P12	P13	P14	P15	P16	P17	P18	P19	P20	P21	P22	P23	P24	P25	P26	P27	P28	P29	P30	P31

Pin No.	34	33	32	31	30	29	28	27	26	25	24	23	22	21	20	19	18	17	16	15	14	13	12	11	10	9	8	7	6	5	4	3	2	1	
Connection	P32	P33	P34	P35	P36	P37	NX	NX	NX	NX	NX	NX	NX	NX	17G	16G	15G	14G	13G	12G	11G	10G	9G	8G	7G	6G	5G	4G	3G	2G	1G	NP	NP	F1	F1

Note : 1) Fn Filament pin 2) nG Grid pin 3) Pn Anode pin 4) NP No pin 5) NX No extended pin

● GRID ASSIGNMENT

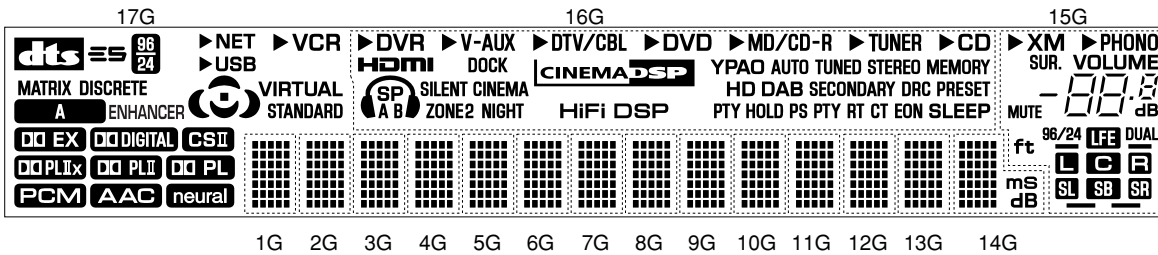

1G 2G 3G 4G 5G 6G 7G 8G 9G 10G 11G 12G 13G 14G

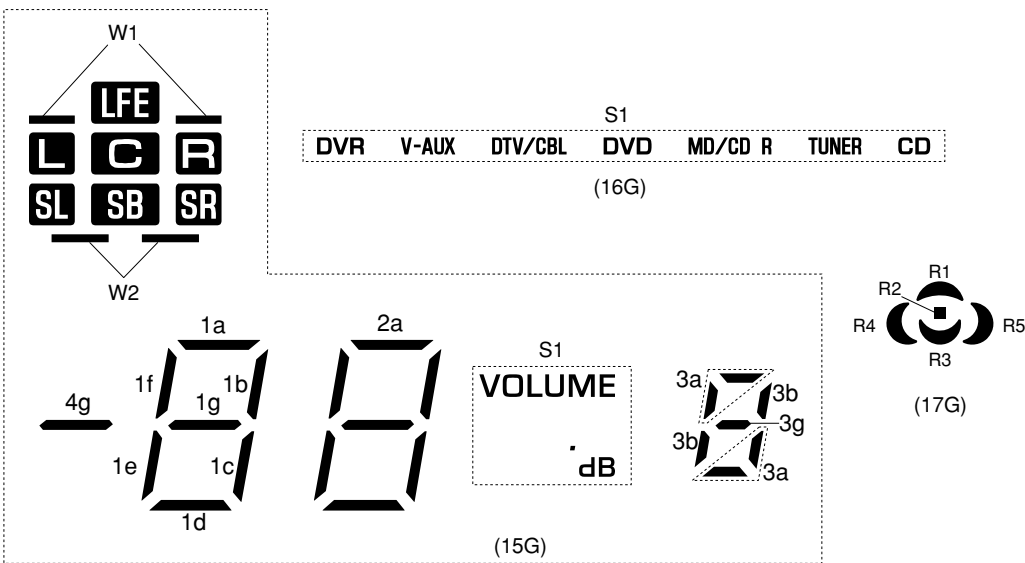
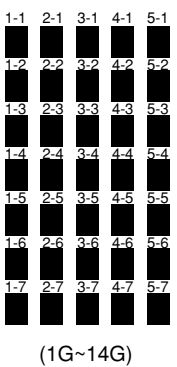

RX-V559/HTR-5950/DSP-AX559

● ANODE CONNECTION

	17G	16G	15G	14G	13G~1G
P1		S1	S1	1-1	1-1
P2		▶ DVR	W1	2-1	2-1
P3	MATRIX	▶ V-AUX	W2	3-1	3-1
P4	DISCRETE	▶ DTV/CBL	4g	4-1	4-1
P5		▶ DVD	1a	5-1	5-1
P6		▶ MD/CD-R	1b	1-2	1-2
P7	ENHANCER	▶ TUNER	1c	2-2	2-2
P8		▶ CD	1d	3-2	3-2
P9		HDMI	1e	4-2	4-2
P10			1f	5-2	5-2
P11		SP	1g	1-3	1-3
P12		A	2a	2-3	2-3
P13		B	2b	3-3	3-3
P14		SILENT CINEMA	2c	4-3	4-3
P15		ZONE2	2d	5-3	5-3
P16		NIGHT	2e	1-4	1-4
P17	NET	DOCK	2f	2-4	2-4
P18	USB		2g	3-4	3-4
P19	VCR	HiFi DSP	3g	4-4	4-4
P20	▶ NET	YPAO	3b	5-4	5-4
P21	▶ USB	AUTO	3a	1-5	1-5
P22	▶ VCR	TUNED	XM	2-5	2-5
P23	R1	STEREO	PHONO	3-5	3-5
P24	R2	MEMORY	▶ XM	4-5	4-5
P25	R3	HD	▶ PHONO	5-5	5-5
P26	R4	DAB	SUR.	1-6	1-6
P27	R5	SECONDARY	MUTE	2-6	2-6
P28	VIRTUAL	DRC	DUAL	3-6	3-6
P29	STANDARD	PRESET	96/24	4-6	4-6
P30	—	PTY HOLD	ft	5-6	5-6
P31	—	HOLD		1-7	1-7
P32	—	PS		2-7	2-7
P33	—	PTY		3-7	3-7
P34	—	RT		4-7	4-7
P35	—	CT		5-7	5-7
P36	—	EON		ms	—
P37	—	SLEEP		dB	—

HTR-5950

■ DISPLAY DATA

- V3000 : 17-BT-26GNK (WG473900)

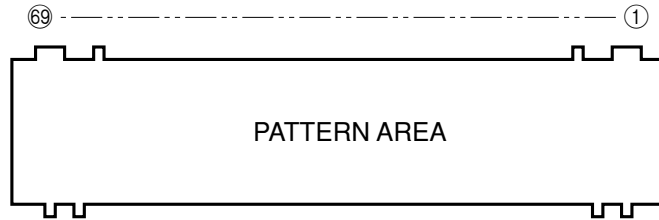

● PIN CONNECTION

Pin No.	69	68	67	66	65	64	63	62	61	60	59	58	57	56	55	54	53	52	51	50	49	48	47	46	45	44	43	42	41	40	39	38	37	36	35
Connection	F2	NX	NP	NP	P1	P2	P3	P4	P5	P6	P7	P8	P9	P10	P11	P12	P13	P14	P15	P16	P17	P18	P19	P20	P21	P22	P23	P24	P25	P26	P27	P28	P29	P30	P31

Pin No.	34	33	32	31	30	29	28	27	26	25	24	23	22	21	20	19	18	17	16	15	14	13	12	11	10	9	8	7	6	5	4	3	2	1
Connection	P32	P33	P34	P35	P36	P37	NX	NX	NX	NX	NX	NX	NX	17G	16G	15G	14G	13G	12G	11G	10G	9G	8G	7G	6G	5G	4G	3G	2G	1G	NP	NP	NX	F1

Note : 1) F1, F2 Filament pin 2) NP No pin 3) NX No extend pin 4) 1G~17G Grid pin

● GRID ASSIGNMENT

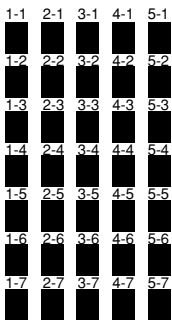
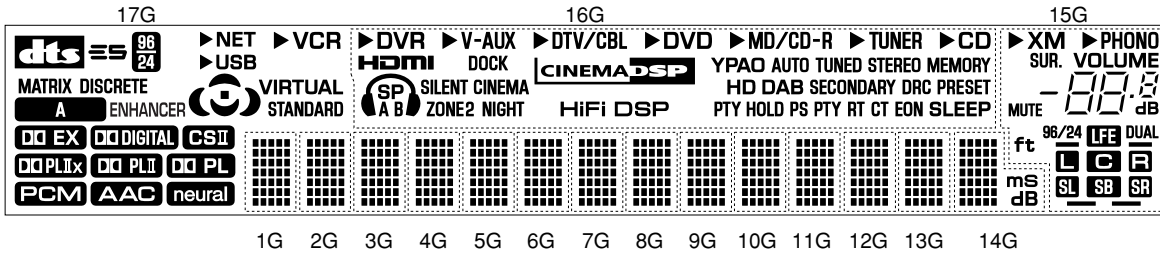



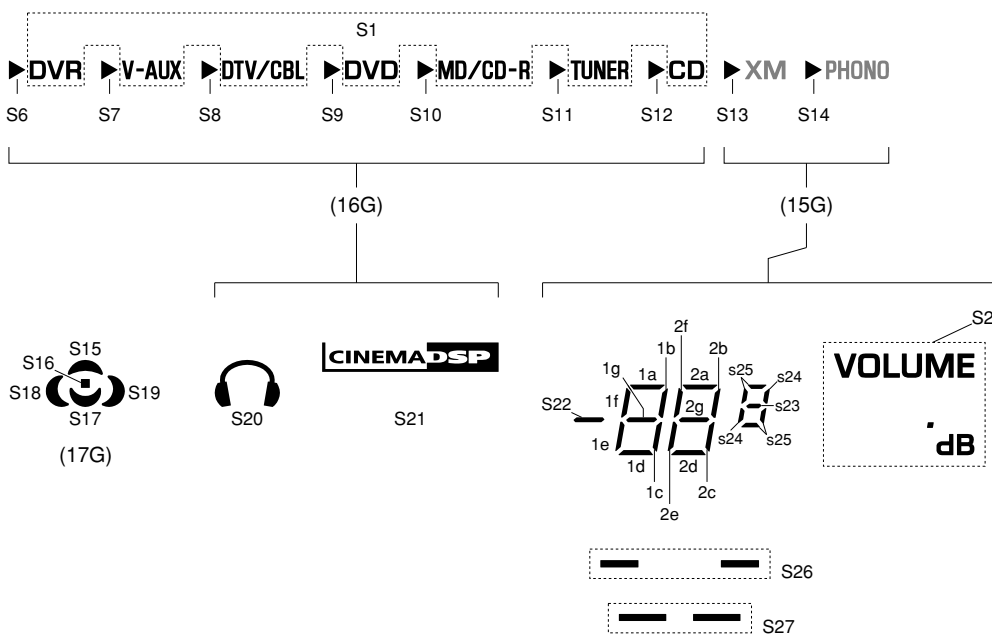

















(1G~14G)



RX-V559/HTR-5950/DSP-AX559

● ANODE CONNECTION

	1G~13G	14G	15G	16G	
1P	1-1	1-1	S2	S1	
2P	2-1	2-1	S26	S6	
3P	3-1	3-1	S27	S7	MATRIX
4P	4-1	4-1	S22	S8	DISCRETE
5P	5-1	5-1	1a	S9	
6P	1-2	1-2	1b	S10	
7P	2-2	2-2	1c	S11	ENHANCER
8P	3-2	3-2	1d	S12	
9P	4-2	4-2	1e	HDMI	
10P	5-2	5-2	1f	S20	
11P	1-3	1-3	1g	SP	
12P	2-3	2-3	2a	A	
13P	3-3	3-3	2b	B	
14P	4-3	4-3	2c	SILENT CINEMA	
15P	5-3	5-3	2d	ZONE2	
16P	1-4	1-4	2e	NIGHT	
17P	2-4	2-4	2f	DOCK	NET
18P	3-4	3-4	2g	S21	USB
19P	4-4	4-4	S23	HiFi DSP	VCR
20P	5-4	5-4	S24	YPAO	
21P	1-5	1-5	S25	AUTO	
22P	2-5	2-5	XM	TUNED	
23P	3-5	3-5	PHONO	STEREO	
24P	4-5	4-5	S13	MEMORY	
25P	5-5	5-5	S14	HD	
26P	1-6	1-6	SUR.	DAB	
27P	2-6	2-6	MUTE	SECONDARY	
28P	3-6	3-6	DUAL	DRC	VIRTUAL
29P	4-6	4-6	96/24	PRESET	STANDARD
30P	5-6	5-6	ft	PTY HOLD	
31P	1-7	1-7		HOLD	
32P	2-7	2-7		PS	
33P	3-7	3-7		PTY	
34P	4-7	4-7		RT	
35P	5-7	5-7		CT	
36P	—	mS		EON	
37P	—	dB		SLEEP	

IC DATA

IC2 : M30625MHP-A98GP (DSP P.C.B.)
Microprocessor

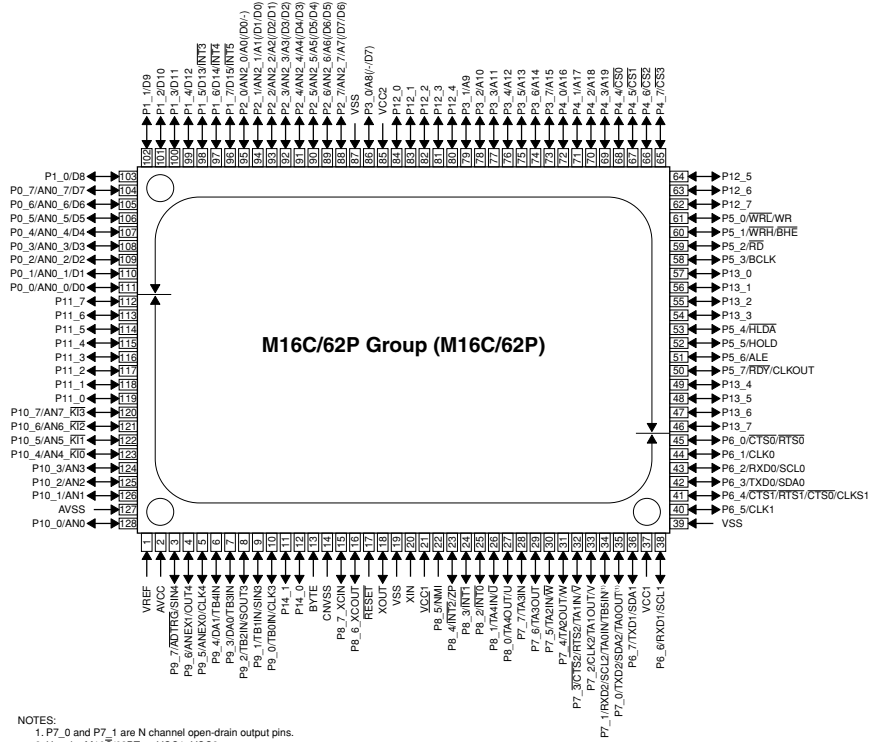

NOTES:
1. P7_0 and P7_1 are N channel open-drain output pins.
2. Use the M16C/62PT on VCC1=VCC2.

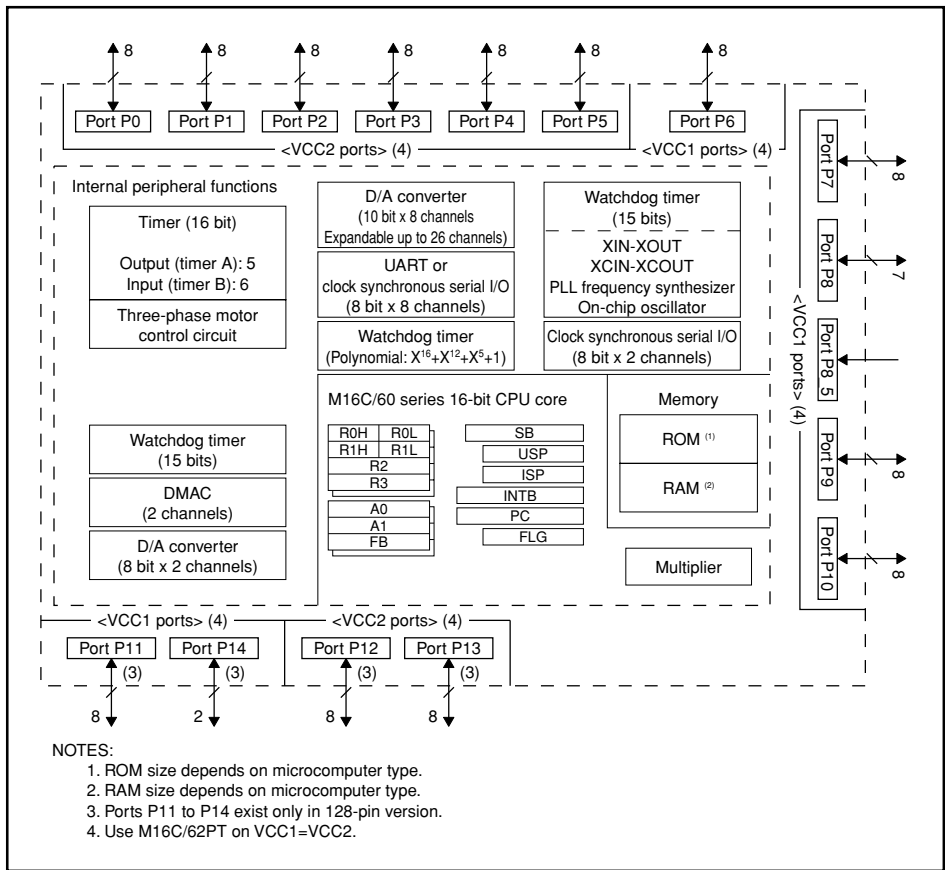

NOTES:
1. ROM size depends on microcomputer type.
2. RAM size depends on microcomputer type.
3. Ports P11 to P14 exist only in 128-pin version.
4. Use M16C/62PT on VCC1=VCC2.

RX-V559/HTR-5950/
DSP-AX559

IC2 : M30625MHP-A98GP (DSP P.C.B.)
Microprocessor

No.	Port Name	Terminal Name	I/O				Function
			PowerOn	Pure Direct	Standby	Sleep	
1	Vref	Vref	MCU		MCU	MCU	AD reference
2	Avcc	Avcc	MCU		MCU	MCU	AD power supply
3	P97/Adtrg/Sin4	CEFD	O		O	O	FL Driver CE
		MOD0			I		MODEL distinction 0
4	P96/ANEX1/SOUT4	DTFD	SO		O	O	FL Driver TxD
5	P95/ANEX0/CLK4	CKFD	SO		O	O	FL Driver CLOCK
6	P94/DA1/TB4in	LC	DA		O	O	Limiter control output
7	P93/DA0/TB3in	XMPWR	O		O	O	XM/DT BUS POWER CONTROL (U model)
8	P92/TB2in/SOUT3	SDM	SO		O	O	Serial data output to DIR, TI (DA70Y), DAC / DIR: 4M, LSBF/TI: 1M, MSBF
9	P91/TB1in/SIN3	SDD	SI		O	O	Serial data input from DIR, TI (DA70Y)
10	P90/TB0in/CLK3	SCK	SO		O	O	Serial clock output to DIR, TI (DA70Y) DAC
11	P141	/ICCNV	O	O	O	O	Reset I2C device of CONV (RX-V559 model)
12	P140	NW_RST	O		O	O	Reset signal to Net-module (RX-V559 model)
13	BYTE	BYTE	MCU		MCU	MCU	Vss : When single chip mode is used
14	CNVss	CNVss	MCU		MCU	MCU	Vss : When single chip mode is used, Vcc : When flash writing is used
15	P87/Xcin	MUTETI	O		O	O	MUTE of TI decoder DSP DA70Y (HI=MUTE)
16	P86/Xcout	/TIBUSY	I		O	O	TI BUSY detection / CDDA writing DATA input
17	/RESET	/RES	MCU		MCU	MCU	Reset
18	Xout	Xout	MCU		MCU	MCU	Oscillation output
19	Vss	Vss	MCU		MCU	MCU	Ground for microprocessor
20	Xin	Xin	MCU		MCU	MCU	Oscillation input
21	Vcc1	Vcc	MCU		MCU	MCU	Power supply +5V for microprocessor
22	P85/NMI	NMI	MCU		MCU	MCU	No used, connect Vss
23	P84/INT2	/INTTI	IRQ		O	O	Interrupt of TI decoder DSP DA70Y
24	P83/INT1	/INTDIR	IRQ		O	O	Interrupt of DIR
25	P82/INT0	/VSY	IRQ	O	O	O	Interrupt of Vertical sync Pulse (RX-V559/DSP-AX559 models)
26	P81/TA4in/U	/CSDIR	O		O	O	Chip enable of DIR
27	P80/TA4out/U	/CSTI	O		O	O	Chip enable of TI decoder DSP DA70Y
28	P77/TA3in	/CSDAC	O		O	O	Chip enable of DAC (2ch/8ch common)
29	P76/TA3out	/ICDIR	O		O	O	DIR reset
30	P75/TA2in/W	/ICTI	O		O	O	Reset of TI decoder DSP DA70Y
31	P74/TA2out/W	/SPIRDY	I		O	O	TI DA70Y Serial Ready / WCK input for CDDA writing
32	P73/CTS2/RTS2/TA1in/V	/CEEEP	O		O	O	EEPROM CE
33	P72/CLK2/TA1out/V	FET	O		O	O	Control of flash writing
34	P71/RXD2/SCL2/TA0in/TB5in	DRXM	SI		O	O	XMDT IC RxDU (U model)
35	P70/TXD2/SDA2/TA0out	DTXM	SO		O	O	XMDT IC TxDU
36	P67/TXD1/SDA1	SDA	SO	I	I	I	IIC data I/O for VIDEO (RX-V559/DSP-AX559 models)
		TXDF	SO				Data transmission terminal of AF220
37	Vcc1	Vcc	MCU		MCU	MCU	Power supply +5V for microprocessor
38	P66/RXD1/SCL1	SCL	SO	I	I	I	IIC clock I/O for VIDEO, Clock speed: 100kHz (RX-V559/DSP-AX559 models)
		RXDF	SO				Flash ROM RxD
39	Vss	Vss	MCU		MCU	MCU	Ground for microprocessor
40	P65/CLK1	N.C.	O		O	O	
		CLKF	SO				Clock transmission terminal signal output for AF220
41	P64/CTS1/RTS1/CTS0/CLKS1	BSY	O				BUSY signal output for AF220
42	P63/TXD0/SDA0	TXDi	SO		O	O	serial data output for iPod (HTR-5950 model)
		TXDNW	SO		O	O	serial data output for iPod/Net-module (RX-V559/DSP-AX559 models)
43	P62/RXD0/SCL0	RXDi	SI		O	O	Serial data input for iPod (HTR-5950 model)
		RXDNW	SI		O	O	Serial data output for iPod/Net-module (RX-V559/DSP-AX559 models)
44	P61/CLK0	iPDET	I		O	O	iPod detection
45	P60/CTS0/RTS0	iPAP	I		O	O	iPod accessories power detection
46	P137	Z2RY	O		O	O	
		YST	O		O	O	
47	P136	/4ohm	O		O	O	IMPEDANCE control / ±B voltage control
48	P135	SBRY	O		O	O	SURROUND BACK SP relay output
49	P134	SPC	O		O	O	CENTER and SURROUND SP relay output
50	P57/RDY/CLKout	SPB	O		O	O	FRONT B SP relay output

IC2 : M30625MHP-A98GP (DSP P.C.B.)
Microprocessor

No.	Port Name	Terminal Name	I/O				Function
			PowerOn	Pure Direct	Standby	Sleep	
51	P56/ALE	SPA	O		O		FRONT A SP relay output
52	P55/HOLD	/EMP	I				For FLASH writing (LO)
53	P54/HLDA	PRI	I		O	O	Protection overcurrent detection
54	P133	PSV	O		O	O	Power Save
55	P132	PRY	O		O	O	Power relay output
56	P131	MASTER	I		O	O	MASTER ON/OFF
57	P130	/BLK	O		O	O	FL Driver turning off
58	P53/BCLK	ISA	I		O	O	INPUT Selector Rotary A
59	P52/RD	ISB	I		O	O	INPUT Selector Rotary B
60	P51/WRH/BHE	TONEA	I		O	O	Tone Control Rotary A
61	P50/WRL/WR	/CE	I				For FLASH writing (HI)
62	P127	TONEB	I		O	O	Tone Control Rotary B
63	P126	VRA	I		O	O	Volume Rotary A
64	P125	VRB	I		O	O	Volume Rotary B
65	P47/CS3	VIA	O	O	O	O	VIDEO Selector A
66	P46/CS2	VIB	O	O	O	O	VIDEO Selector B
67	P45/CS1	VIC	O	O	O	O	VIDEO Selector C
68	P44/CS0	S/V	O	O	O	O	OSD input S/Composite change (RX-V559/DSP-AX559 models)
69	P43/A19	/CES	O	O	O	O	OSD Enable (RX-V559/DSP-AX559 models)
		MOD1	I				MODEL distinction 1
70	P42/A18	SVIDD	I	O	O	O	S-Video Signal Detector
71	P41/A17	BYPASS	O	O	O	O	VIDEO Bypass/ conversion change
72	P40/A16	/INTCNV	I	O	O	O	Interrupt request of VIDEO DEC/ENC IC (RX-V559/DSP-AX559 models)
73	P37/A15	/VR1	O	O	O	O	VIDEO Rec Out 1 MUTE
74	P36/A14	/VR2	O	O	O	O	
75	P35/A13	/PURD	O			I	
76	P34/A12	/MON	O	O	O	O	VIDEO Mon Out MUTE
77	P33/A11	CPNTD	I	O	O	O	Component Signal Detector (DVD)
78	P32/A10	CMP0	O	O	O	O	Component Selector 0
79	P31/A9	CMP1	O	O	O	O	Component Selector 1
80	P124	CBYPASS	O	O	O	O	Component Bypass/Conversion change (RX-V559/DSP-AX559 models)
81	P123	/CNONE	O	O	O	O	Component MonOut MUTE
82	P122	TRIG	O		O	O	DC TRIGGER input
83	P121	TMT	O		O	O	TUNER MUTE
84	P120	SDRN	I		O	O	RDS RxDBG
85	Vcc2	Vcc	MCU		MCU	MCU	Power supply +5V for microprocessor
86	P30/A8	SCKN	O		O	O	RDS IC Clock (G model)
			O	O	O	O	OSD IC Clock (RX-V559/DSP-AX559 models)
87	Vss	Vss	MCU		MCU	MCU	Ground for micro-processor
88	P27/A7	SDTN	O		O	O	RDS IC TxD (G model)
			O	O	O	O	OSD IC TxD (RX-V559/DSP-AX559 models)
89	P26/A6	RDSE	O		O	O	RDS Enable (G model)
		/ICXM	O		O	O	DABIC IC reset (U model)
90	P25/A5	SCKP	O		O	O	PLL IC Clock
91	P24/A4	SDTP	O		O	O	PLL IC TxD
92	P23/A3	CEP	O		O	O	PLL IC Enable
93	P22/A2	SDRP	I+		O	O	PLL IC RxD
94	P21/A1	/ST	I+		O	O	TUNER /ST
95	P20/A0	TUNED	I+		O	O	TUNED
96	P17/D15/INT5	PDET	IRQ		IRQ	O	Power Down DETECT INT
97	P16/D14/INT4	/PSW	IRQ		IRQ	O	Interrupt MASTER / MAIN / Zone2 Power SW
98	P15/D13/INT3	REM	IRQ		IRQ	O	Remote Control input
99	P14/D12	/HP	I		O	O	HEAD PHONE detection
100	P13/D11	/MTHP	O		O	O	HEAD PHONE MUTE input
101	P12/D10	/MTFS	O		O	O	MUTE Front/Surround, PreOUT
102	P11/D9	/MTCT	O		O	O	MUTE Center
103	P10/D8	/MTSW	O		O	O	MUTE SW
104	P07/D7	/MTZ2	O		O	O	Zone 2 MUTER
105	P06/D6	CKEV	O		O	O	Electron volume IC Clock

RX-V559/HTR-5950/
DSP-AX559

IC2 : M30625MHP-A98GP (DSP P.C.B.)
Microprocessor

No.	Port Name	Terminal Name	I/O				Function
			PowerOn	Pure Direct	Standby	Sleep	
106	P05/D5	DTEV	O		O	O	Electron volume IC DATA
107	P04/D4	CKZ2	O		O	O	Zone2 Selector (BD3841) Clock (R model)
108	P03/D3	DTZ2	O		O	O	Zone2 Selector (BD3841) DATA (R model)
109	P02/D2	N.C.	O		O	O	
110	P01/D1	N.C.	O		O	O	
111	P00/D0	CKEX	O		O	O	EX. INPUT Selector Clock
112	P117	DTEX	O		O	O	EX. INPUT Selector DATA
113	P116	CKBD	O		O	O	
114	P115	DTBD	O		O	O	
		MOD2			I		MODEL distinction 2
115	P114	DTSEL	O		O	O	
116	P113	CKSEL	O		O	O	
117	P112	CESEL	O		O	O	
		MOD4			I		MODEL distinction (RX-V559/DSP-AX559 models)
118	P111	ICEV	O		O	O	
119	P110	CEEV	O		O	O	
		MOD3			I		MODEL distinction (RX-V559 model)
120	P107/AN7/KI3	PRV2	AD		O	O	
121	P106/AN6/KI2	PRV1	AD		O	O	AD protection power-supply voltage detection
122	P105/AN5/KI1	PRD	AD		O	O	AD protection DC detection
123	P104/AN4/KI0	PLDET	AD		O	O	AD POWER LIMITER detection
124	P103/AN3	THM	AD		O	O	AD temperature detection
125	P102/AN2	ADKEY0	AD		O	O	AD Key 0
126	P101/AN1	ADKEY1	AD		O	O	AD Key 1
127	Avss	Avss	MCU		MCU	MCU	Ground for AD
128	P100/AN0	DEST	AD		O	O	AD model detection

RX-V559/DSP-AX559

Key Input(A-D) Pull-Up Resistance 10 k-Ohms

Ohm	+0.0k	+1.0k	+1.0k	+1.5k	+2.2k	+3.3k	+4.7k	+4.7k	+6.8k	+10.0k	+22.0k
V	~0.3	~0.7	~1.0	~1.5	~2.0	~2.6	~3.1	~3.4	~3.7	~4.0	~4.4
ADKEY0 94pin/AN2	MAIN/ZONE ON/OFF	-	-	-	INPUT MODE	STRAIGHT	TONE CONTROL	PRESET/TUNING	SPEAKER B	SPEAKER A	-
ADKEY1 95pin/AN1	ZONE2 ON/OFF	-	-	ZONE CONTROL	MULTI CH INPUT	FM/AM	A/B/C/D/E	PRESET/TUNING <	PRESET/TUNING >	MEMORY	TUNING MODE

HTR-5950

Key Input(A-D) Pull-Up Resistance 10 k-Ohms

Ohm	+0.0k	+1.0k	+1.0k	+1.5k	+2.2k	+3.3k	+4.7k	+4.7k	+6.8k	+10.0k	+22.0k
V	~0.3	~0.7	~1.0	~1.5	~2.0	~2.6	~3.1	~3.4	~3.7	~4.0	~4.4
ADKEY0 94pin/AN2	PROGRAM <	PROGRAM <	BASS/TREBLE -	BASS/TREBLE +	INPUT MODE	STRAIGHT	TONE CONTROL	PRESET/TUNING	SPEAKER B	SPEAKER A	PURE DIRECT
ADKEY1 95pin/AN1	-	-	-	-	MULTI CH INPUT	FM/AM	A/B/C/D/E	PRESET/TUNING <	PRESET/TUNING >	MEMORY	TUNING MODE

MODEL Distinction Port / モデル判別ポート

Pin	Function	Name	RX-V559/DSP-AX559	HTR-5950
3	P97/Adtrg/Sin4	CEFD/MOD0	0	1
69	P43/A19	CES/MOD1	0	0
114	P115	DTBD/MOD2	1	1
119	P110	CEEV/MOD3	0	0
117	P112	CESEL/MOD4	0	0

Distinction for AD Port / 仕向け先判別ポート

Pull-Up Resistance 10 k-Ohms

Ohm	0.0k	1.2k	2.7k	4.7k	6.8k	10.0k	15.0k	27.0k	47.0k	100.0k	∞
V	0-0.2	0.3-0.8	0.9-1.3	1.4-1.8	1.8-2.2	2.3-2.7	2.8-3.3	3.4-3.8	3.9-4.3	4.4-4.7	4.8-5.0
A-D (5V=255)	0-13	14-40	41-68	69-92	93-115	116-140	141-170	171-198	199-221	222-244	245-255
DEST 129pin	J	U, C	-	R	T	K	A	-	G, E	L	-

IC56 : LC89057W-VF4-E (DSP P.C.B)
Digital Audio Interface Transceiver

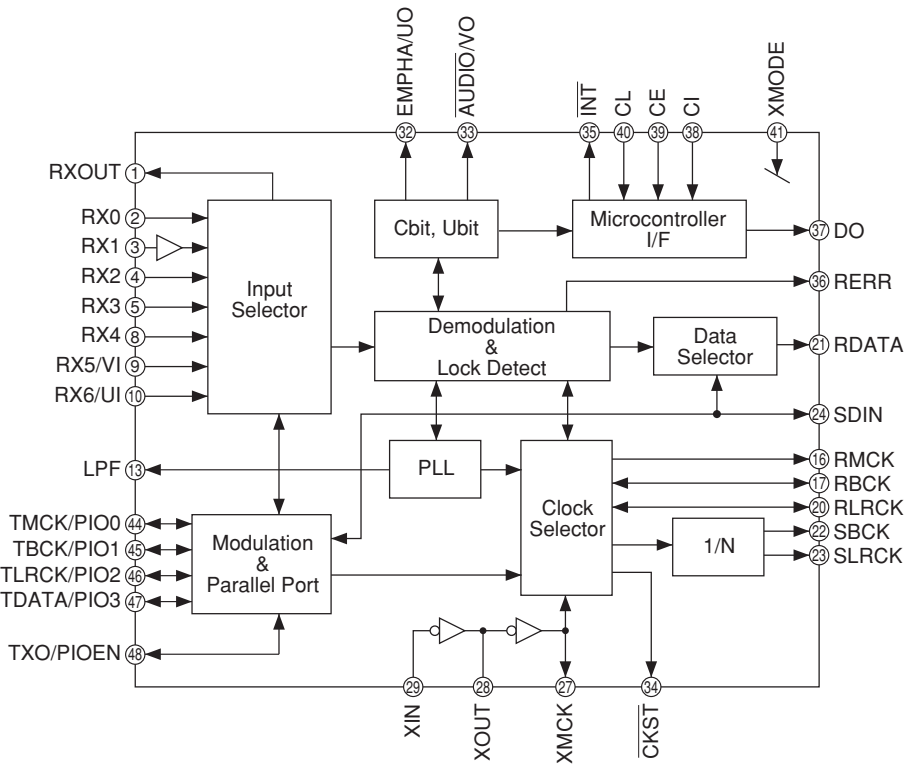
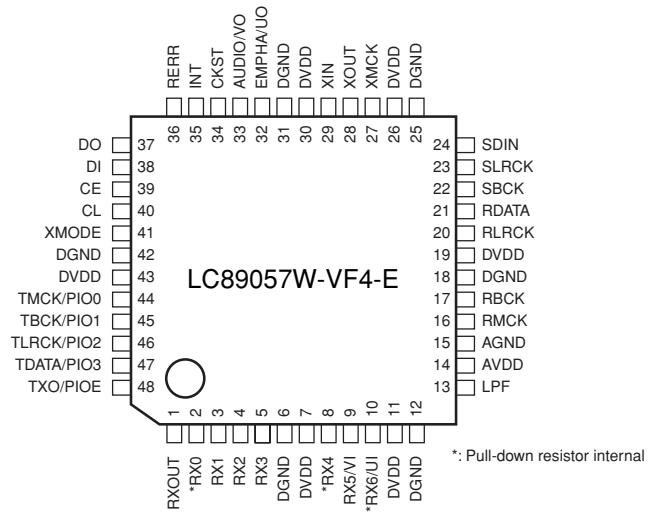

RX-V559/HTR-5950/
DSP-AX559

IC56 : LC89057W-VF4-E (DSP P.C.B)
Digital Audio Interface Transceiver

No.	Name	I/O	Function
1	RXOUT	O	Input bi-phase selection data output pin
2	RX0	Is	TTL-compatible digital data input pin
3	RX1	I	Coaxial-compatible digital data input pin with built-in amplifier
4	RX2	Is	TTL-compatible digital data input pin
5	RX3	Is	TTL-compatible digital data input pin
6	DGND		Digital GND
7	DVDD		Digital power supply
8	RX4	Is	TTL-compatible digital data input pin
9	RX5/VI	Is	TTL-compatible digital data / Validity flag input pin for modulation
10	RX6/UI	Is	TTL-compatible digital data / User data input pin for modulation
11	DVDD		PLL digital power supply
12	DGND		PLL digital GND
13	LPF	O	PLL loop filter connection pin
14	ACDD		PLL analog power supply
15	AGND		PLL analog GND
16	RMCK	O	R system clock output pin (256fs, 512fs, XIN, VCO)
17	RBCK	O/I	R bit clock input/output pin
18	DGND		Digital GND
19	DVDD		Digital power supply
20	RLRCK	O/I	R LR clock input/output pin (fs)
21	RDATA	O	Serial audio data input pin
22	SBCK	O	S bit clock output pin (32fs, 64fs, 128fs)
23	SLRCK	O	S LR clock output pin (fs/s, fs, 2fs)
24	SDIN	Is	Serial audio data input pin
25	DGND		Digital GND
26	DVDD		Digital power supply
27	XMCK	O	Oscillation amplifier output pin
28	XOUT	O	Crystal resonator connection output pin
29	XIN	I	Crystal resonator connection, external supply clock input pin (24.576 MHz or 12.288 MHz)
30	DVDD		Digital power supply
31	DGND		Digital GND
32	EMPHA/UO	I/O	Emphasis information / U data output / Chip address setting pin
33	AUDIO/VO	I/O	Non-PCM output / V flag output / Chip address setting pin
34	CKST	I/O	Clock switch transition period signal / Demodulation master or slave function switch pin
35	INT	I/O	Microcontroller interrupt output / Modulation or general-purpose I/O switch pin
36	RERR	O	PLL clock error, data error flag output
37	DO	O	Microcontroller I/F read data output pin (3-state)
38	DI	Is	Microcontroller I/F write data input pin
39	CE	Is	Microcontroller I/F chip enable input pin
40	CL	Is	Microcontroller I/F clock input pin
41	XMODE	Is	System reset input pin
42	DGND		Digital GND
43	DVDD		Digital power supply
44	TMCK/PIO0	I/O	Modulation 256fs system clock input / General-purpose I/O input/output pin
45	TMCK/PIO1	I/O	Modulation 64fs bit clock input / General-purpose I/O input/output pin
46	TLRCK/PIO2	I/O	Modulation fs clock input / General-purpose I/O input/output pin
47	TLRCK/PIO3	I/O	Modulation serial audio data input / General-purpose I/O input/output pin
48	TXO/PIOEN	O/I	Modulation data output / General-purpose I/O enable input pin

- 1) Input/output I or O = -0.3 to 3.6V, Is = -0.3 to 5.5V
- 2) Pins 32 and 33 are latch address setting input pins when pin 41 = "L".
- 3) Pin 34 is a demodulation function master or slave setting input pin when pin 41 = "L".
- 4) Pin 35 is a modulation function or general-purpose I/O function switch setting input pin when pin 41 = "L".
- 5) Perform ON/OFF for all power supplies with the same timing as a latch-up countermeasure.

IC60 : D70YE101RFP250 (DSP P.C.B)
Decoder/Post Processor

* No replacement part available. / サービス部品供給なし

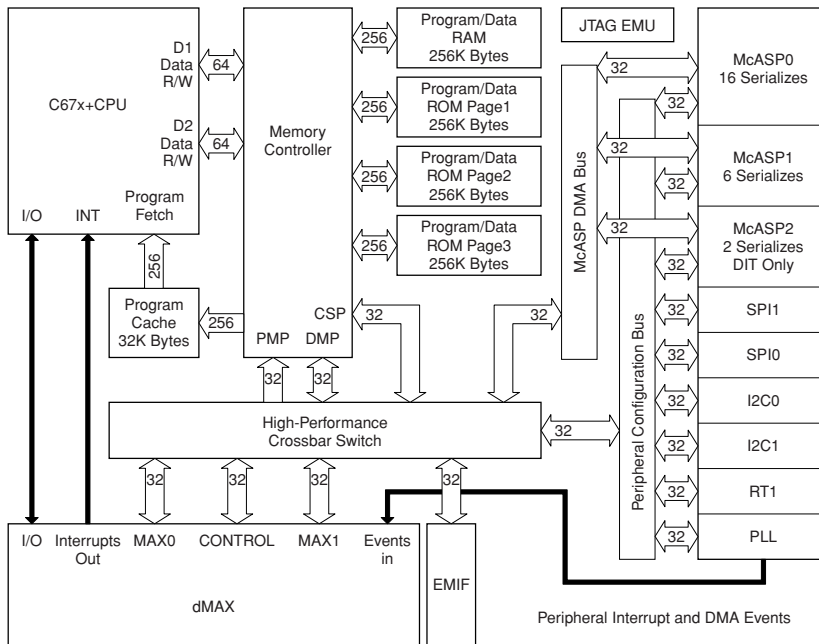
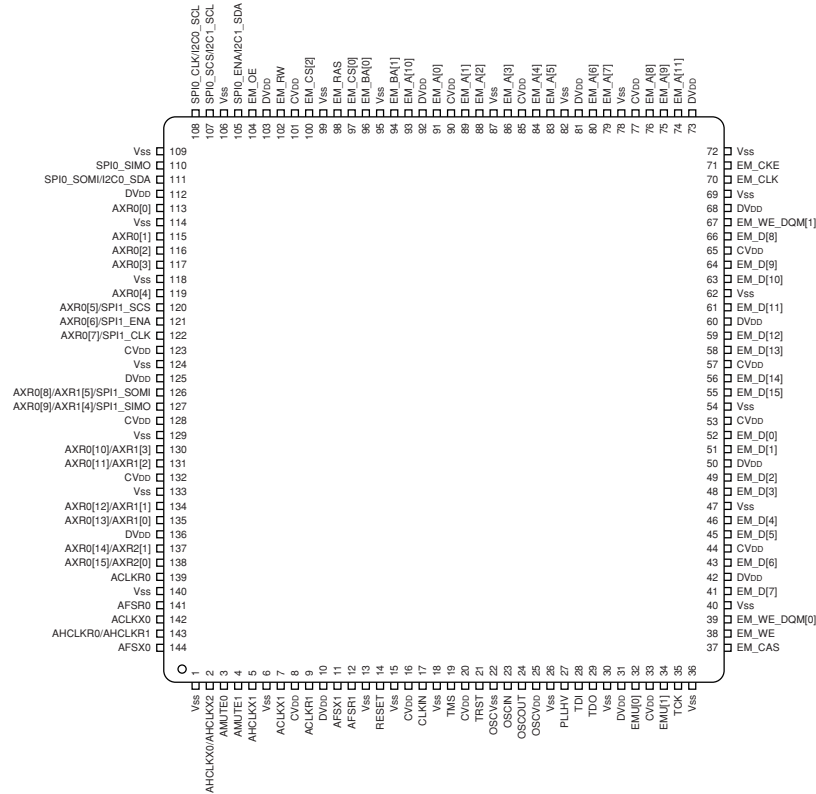

RX-V559/HTR-5950/
DSP-AX559

IC60 : D70YE101RFP250 (DSP P.C.B)
Decoder/Post Processor

PIN NO.	SIGNAL NAME	TYPE ⁽¹⁾	PULL ⁽²⁾	GPIO ⁽³⁾	DESCRIPTION
1	Ground(Vss)				
2	AHCLKX0/AHCLKX2	IO	-	Y	McASP0 and McASP2 Transmit Master Clock
3	AMUTE0	IO	-	Y	McASP0 MUTE Output
4	AMUTE1	IO	-	Y	McASP1 MUTE Output
5	AHCLKX1	IO	-	Y	McASP1 Transmit Master Clock
6	Ground(Vss)				
7	ACLKX1	IO	-	Y	McASP1 Transmit Bit Clock
8	Core Supply (CVpp)				
9	ACLKR1	IO	-	Y	McASP1Receive Bit Clock
10	IO Supply (DVpp)				
11	AFSX1	IO	-	Y	McASP1 Transmit Frame Sync (L/R Clock)
12	AFSR1	IO	-	Y	McASP1Receive Frame Sync (L/R Clock)
13	Ground(Vss)				
14	RESET	IO	-	N	Device reset pin
15	Ground(Vss)				
16	Core Supply (CVpp)				
17	CLKIN	IO	-	N	Alternate clock input (3.3-V LVCMOS Input)
18	Ground(Vss)				
19	TMS	IO	IPU	N	Test mode Select
20	Core Supply (CVpp)				
21	TRST	IO	IPU	N	Test Reset
22	OSCVss	PWR	-	N	Oscillator Vss tap point (for filter only)
23	OSCIN	IO	-	N	1.2-V Oscillator Input
24	OSCOUT	O	-	N	1.2-V Oscillator Output
25	OSCVpp	PWR	-	N	Oscillator 1.2-V Vpp tap point (for filter only)
26	Ground(Vss)				
27	PLLHV	PWR	-	N	PLL 3.3-V Supply Input (requires external filter)
28	TDI	IO	IPU	N	Test Data In
29	TDO	OZ	IPU	N	Test Data Out
30	Ground(Vss)				
31	IO Supply (DVpp)				
32	EMU[0]	IO	IPU	N	Emulation Pin 0
33	Core Supply (CVpp)				
34	EMU[1]	IO	IPU	N	Emulation Pin 1
35	TCK	IO	IPU	N	Test Clock
36	Ground(Vss)				
37	EM_CAS	O	-	N	SDRAM Column Address Strobe
38	EM_WE	O	-	N	SDRAM Write Enable
39	EM_WE_DQM[0]	O	-	N	Write Enable or Byte Enable for EM_D[7:0]
40	Ground(Vss)				
41	EM_D[7]	IO	-	N	EMIF Data Bus [lower 16 Bits]
42	IO Supply (DVpp)				
43	EM_D[6]	IO	-	N	EMIF Data Bus [lower 16 Bits]
44	Core Supply (CVpp)				
45	EM_D[5]	IO	-	N	EMIF Data Bus [lower 16 Bits]
46	EM_D[4]	IO	-	N	EMIF Data Bus [lower 16 Bits]
47	Ground(Vss)				
48	EM_D[3]	IO	-	N	EMIF Data Bus [lower 16 Bits]
49	EM_D[2]	IO	-	N	EMIF Data Bus [lower 16 Bits]
50	IO Supply (DVpp)				
51	EM_D[1]	IO	-	N	EMIF Data Bus [lower 16 Bits]
52	EM_D[0]	IO	-	N	EMIF Data Bus [lower 16 Bits]
53	Core Supply (CVpp)				
54	Ground(Vss)				
55	EM_D[15]	IO	-	N	EMIF Data Bus [lower 16 Bits]

IC60 : D70YE101RFP250 (DSP P.C.B)
Decoder/Post Processor

PIN NO.	SIGNAL NAME	TYPE ⁽¹⁾	PULL ⁽²⁾	GPIO ⁽³⁾	DESCRIPTION
56	EM_D[14]	IO	-	N	EMIF Data Bus [lower 16 Bits]
57	Core Supply (CVpp)				
58	EM_D[13]	IO	-	N	EMIF Data Bus [lower 16 Bits]
59	EM_D[12]	IO	-	N	EMIF Data Bus [lower 16 Bits]
60	IO Supply (DVpp)				
61	EM_D[11]	IO	-	N	EMIF Data Bus [lower 16 Bits]
62	Ground(Vss)				
63	EM_D[10]	IO	-	N	EMIF Data Bus [lower 16 Bits]
64	EM_D[9]	IO	-	N	EMIF Data Bus [lower 16 Bits]
65	Core Supply (CVpp)				
66	EM_D[8]	IO	-	N	EMIF Data Bus [lower 16 Bits]
67	EM_WE_DQM[1]	O	-	N	Write Enable or Byte Enable for EM_D[15:8]
68	IO Supply (DVpp)				
69	Ground(Vss)				
70	EM_CLK	O	-	N	SDRAM Clock
71	EM_CKE	O	-	N	SDRAM Clock Enable
72	Ground(Vss)				
73	IO Supply (DVpp)				
74	EM_A[11]	O	-	N	EMIF Address Bus
75	EM_A[9]	O	-	N	EMIF Address Bus
76	EM_A[8]	O	-	N	EMIF Address Bus
77	Core Supply (CVpp)				
78	Ground(Vss)				
79	EM_A[7]	O	-	N	EMIF Address Bus
80	EM_A[6]	O	-	N	EMIF Address Bus
81	IO Supply (DVpp)				
82	Ground(Vss)				
83	EM_A[5]	O	-	N	EMIF Address Bus
84	EM_A[4]	O	-	N	EMIF Address Bus
85	Core Supply (CVpp)				
86	EM_A[3]	O	-	N	EMIF Address Bus
87	Ground(Vss)				
88	EM_A[2]	O	-	N	EMIF Address Bus
89	EM_A[1]	O	-	N	EMIF Address Bus
90	Core Supply (CVpp)				
91	EM_A[0]	O	-	N	EMIF Address Bus
92	IO Supply (DVpp)				
93	EM_A[10]	O	-	N	EMIF Address Bus
94	EM_BA[1]	O	-	N	SDRAM Bank Address and Asynchronous Memory LOW-Order Address
95	Ground(Vss)				
96	EM_BA[0]	O	-	N	SDRAM Bank Address and Asynchronous Memory LOW-Order Address
97	EM_CS[0]	O	-	N	SDRAM Chip Select
98	EM_RAS	O	-	N	SDRAM Row Address Strobe
99	Ground(Vss)				
100	EM_CS[2]	O	-	N	Asynchronous Memory Chip Select
101	Core Supply (CVpp)				
102	EM_RW	O	-	N	Asynchronous Memory Read/not Write
103	IO Supply (DVpp)				
104	EM_OE	O	-	N	SDRAM Output Enable
105	SPI0_ENA/I2C1_SDA	IO	-	Y	SPI0 Enable (Ready) or I2c1 Serial Data
106	Ground(Vss)				
107	SPI0_SCS/I2C1_SCL	IO	-	Y	SPI0 Slave Chip Select or I2c1 Serial Clock
108	SPI0_CLK/I2C0_SCL	IO	-	Y	SPI0 Serial Clock or I2c0 Serial Clock
109	Ground(Vss)				
110	SPI0_SIMO	IO	-	Y	SPI0 Data Pin Slave In Master Out

RX-V559/HTR-5950/
DSP-AX559

IC60 : D70YE101RFP250 (DSP P.C.B)
Decoder/Post Processor

PIN NO.	SIGNAL NAME	TYPE ⁽¹⁾	PULL ⁽²⁾	GPIO ⁽³⁾	DESCRIPTION
111	SPI0_SOMI/I2C0_SDA	IO	-	Y	SPI0 Data Pin Slave Out Master In or I2C0 Serial Data
112	IO Supply (DVpp)				
113	AXR0[0]	IO	-	Y	McASP0 Serial Data 0
114	Ground(Vss)				
115	AXR0[1]	IO	-	Y	McASP0 Serial Data 1
116	AXR0[2]	IO	-	Y	McASP0 Serial Data 2
117	AXR0[3]	IO	-	Y	McASP0 Serial Data 3
118	Ground(Vss)				
119	AXR0[4]	IO	-	Y	McASP0 Serial Data 4
120	AXR0[5]/SOI1_SCS	IO	-	Y	McASP0 Serial Data 5 or SPI1 Slave Chip Select
121	AXR0[6]/SPI1_ENA	IO	-	Y	McASP0 Serial Data 6 or SPI1 Enable (Ready)
122	AXR0[7]/SPI1_CLK	IO	-	Y	McASP0 Serial Data 7 or SPI1 Serial Clock
123	Core Supply (CVpp)				
124	Ground(Vss)				
125	IO Supply (DVpp)				
126	AXR0[8]/AXR1[5]/SPI1_SOMI	IO	-	Y	McASP0 Serial Data 8 or McASP1 Serial Data 5 or SPI1 Data Pin Slave Out Master In
127	AXR0[9]/AXR1[4]/SPI1_SIMO	IO	-	Y	McASP0 Serial Data 9 or McASP1 Serial Data 4 or SPI1 Data Pin Slave In Master Out
128	Core Supply (CVpp)				
129	Ground(Vss)	IO	-	Y	
130	AXR0[10]/AXR1[3]	IO	-	Y	McASP0 Serial Data 10 or McASP1 Serial Data 3
131	AXR0[11]/AXR1[2]				McASP0 Serial Data 11 or McASP1 Serial Data 2
132	Core Supply (CVpp)				
133	Ground(Vss)	IO	-	Y	
134	AXR0[12]/AXR1[1]	IO	-	Y	McASP0 Serial Data 12 or McASP1 Serial Data 1
135	AXR0[13]/AXR1[0]				McASP0 Serial Data 13 or McASP1 Serial Data 0
136	IO Supply (DVpp)	IO	-	Y	
137	AXR0[14]/AXR2[1]	IO	-	Y	McASP0 Serial Data 14 or McASP2 Serial Data 1
138	AXR0[15]/AXR2[0]	IO	-	Y	McASP0 Serial Data 15 or McASP2 Serial Data 0
139	ACLKR0				McASP0 Receive bit Clock
140	Ground(Vss)	IO	-	Y	
141	AFSR0	IO	-	Y	McASP0 Receive Frame Sync (L/R Clock)
142	ACLKX0	IO	-	Y	McASP0 Transmit Bit Clock
143	AHCLKR0/AHCLKR1	IO	-	Y	McASP0 and McASP1 Receive Master Clock
144	AFSX0				McASP0 Transmit Frame Sync (L/R Clock)

PIN CONNECTION DIAGRAM

• ICs

BD3816K1

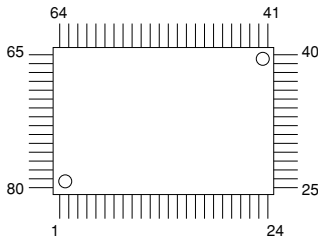

BD3841FS

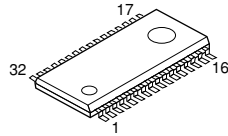

TC74HC4051AF
TC74HC4052AF
TC74HC4053AF
NJM2581M

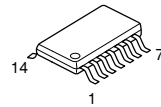

F2602E-01
YAC523-EVR2

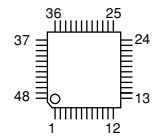

LA7106M-TLM-E
PCM1780DBQR
PCM1781DBQR
PCM1803DBR

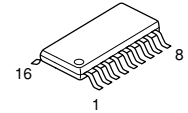

BD3816K1

LA73050-TLM-E

LC72722PM

LC89057W-VF4A-E

LM61CIZ THERMAL

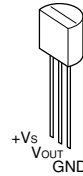
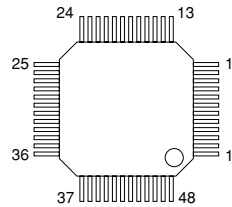
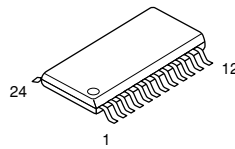
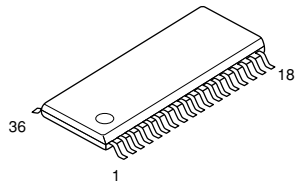
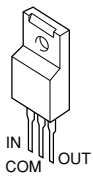

M30625MHP-A98GP

M66003-0131FP

NE5532DR OP AMP

NJM2068LD
NJM2068MD-TE2
NJM4556AL

NJM2388F05 5.0V
NJM2388F33

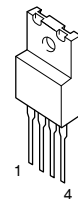
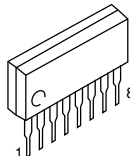
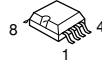
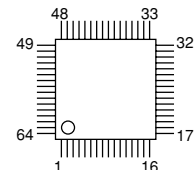
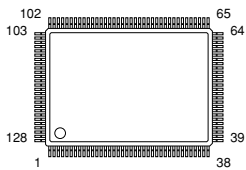

NJM2581M VIDEO AMP

NJM2885DL1-18
NJM2885DL1-33

NJM4565M (TE1)

NJM7812FA

NJM78M05DL1A (TE1)

NJM7805FA 5V
NJM79M05FA
NJM79M12FA

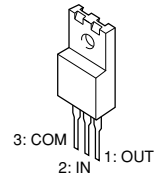
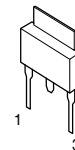
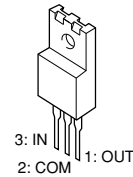
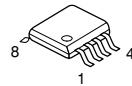
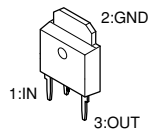
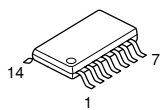

NJU7311AM
NJU7312AM
NJU7313AM

PCM1680DBQR

R1172S121D-E2-F

RH5RE58AA-T1-FA

SN74AHC1G08DCKR

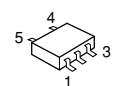
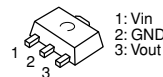
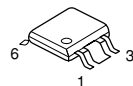
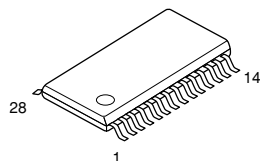
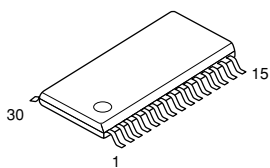

SN74AHCT08PWR

SN74AHCT1G32DCKR

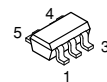
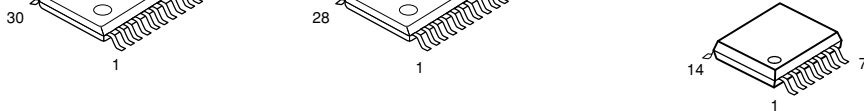

SN74LV157APWR
SN74LVU04APWR

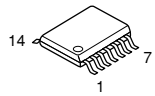

SN74LV245APWR TRAN

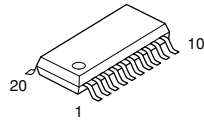

TC4013BP FF
TC74VHCU04FT INVER

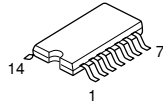

W9816G6CH-7 SDRAM

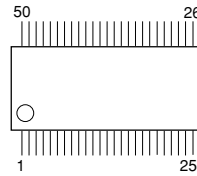

YAC520-EE2

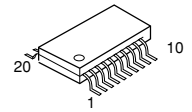

ADV7180

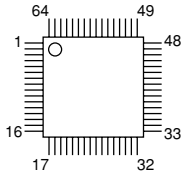

ADV7172

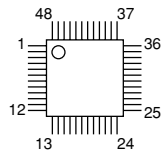

S29AL004D70TF1020

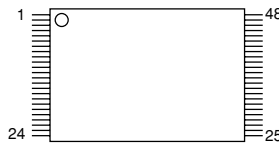

• Diodes

1N4002S
1SS133,176
1SS270A
1SS355
1SS380
1T2
MTZJ13A 13V
MTZJ15A 15V
MTZJ15B 15V
MTZJ2.4B 2.4V
MTZJ27B 27V
MTZJ30A 30V
MTZJ5.1C 5.1V

RB441Q-40 T-77
RB441Q-40 T-77

D2SBA20 1.5A 200V
D5SB20 5A 200V

MA8030-L 2.9V
MA8051-M 5.1V
MA8056-M 5.6V
MA8068-L 6.6V
MA8068-M 6.8V
MA8075-H 7.7V
MA8091-M 9.1V
MA8100-M 10V

RB500V-40
RB501V-40
UDZ 3.6BTE-17 3.6V
UDZ5.1B 5.1V

MA8082-H 8.5V

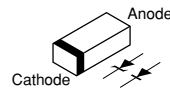
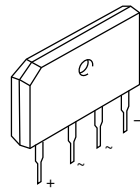
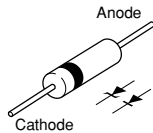
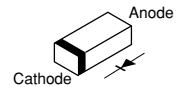

S1NB20 1A 200V
S1NB60 1.0A 600V

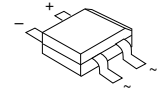

• Transistors

2SA1015 Y
2SA933S Q,R
2SA949 O,Y
2SC1740S QRS
2SC1815 Y
2SC1890A D,E
2SC2229 O,Y
2SC2240 GR,BL

2SC3326 A,B
2SC3837K T146 N,P
2SC3906K T146 R,S

2SB1257
2SB1274 Q,R,S

2SA1695 O,P,Y
2SC4468 O,P,Y
2SD1915F S,T
2SD2014
2SK2158-T2B-A
2SK246 Y
2SK3288
2SK3850

2SA1708 S,T
2SA1770 S,T
2SC4488 S,T
2SC4614 S,T
2SD1938F S,T

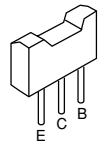
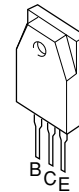
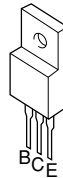
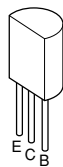

2SA1037K Q,R,S
2SC2412K Q,R,S
DTA114ES
DTC114EKA
DTC114ES
DTC124EKA
DTC144ES



MEMO



BLOCK DIAGRAMS

AUDIO BLOCK DIAGRAM

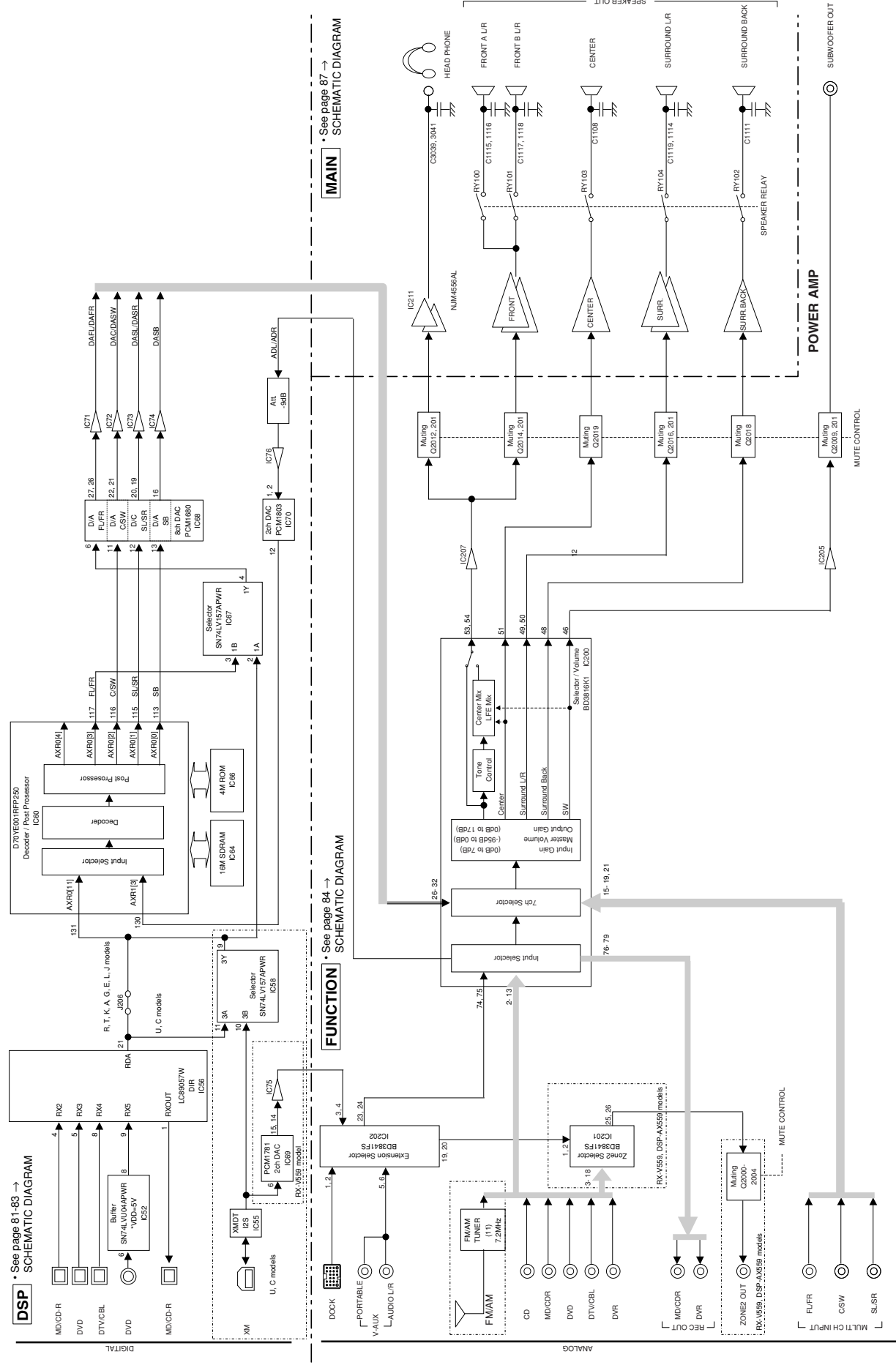

• See page 81-83 → SCHEMATIC DIAGRAM

• See page 84 → SCHEMATIC DIAGRAM

• See page 87 → SCHEMATIC DIAGRAM

VIDEO BLOCK DIAGRAM

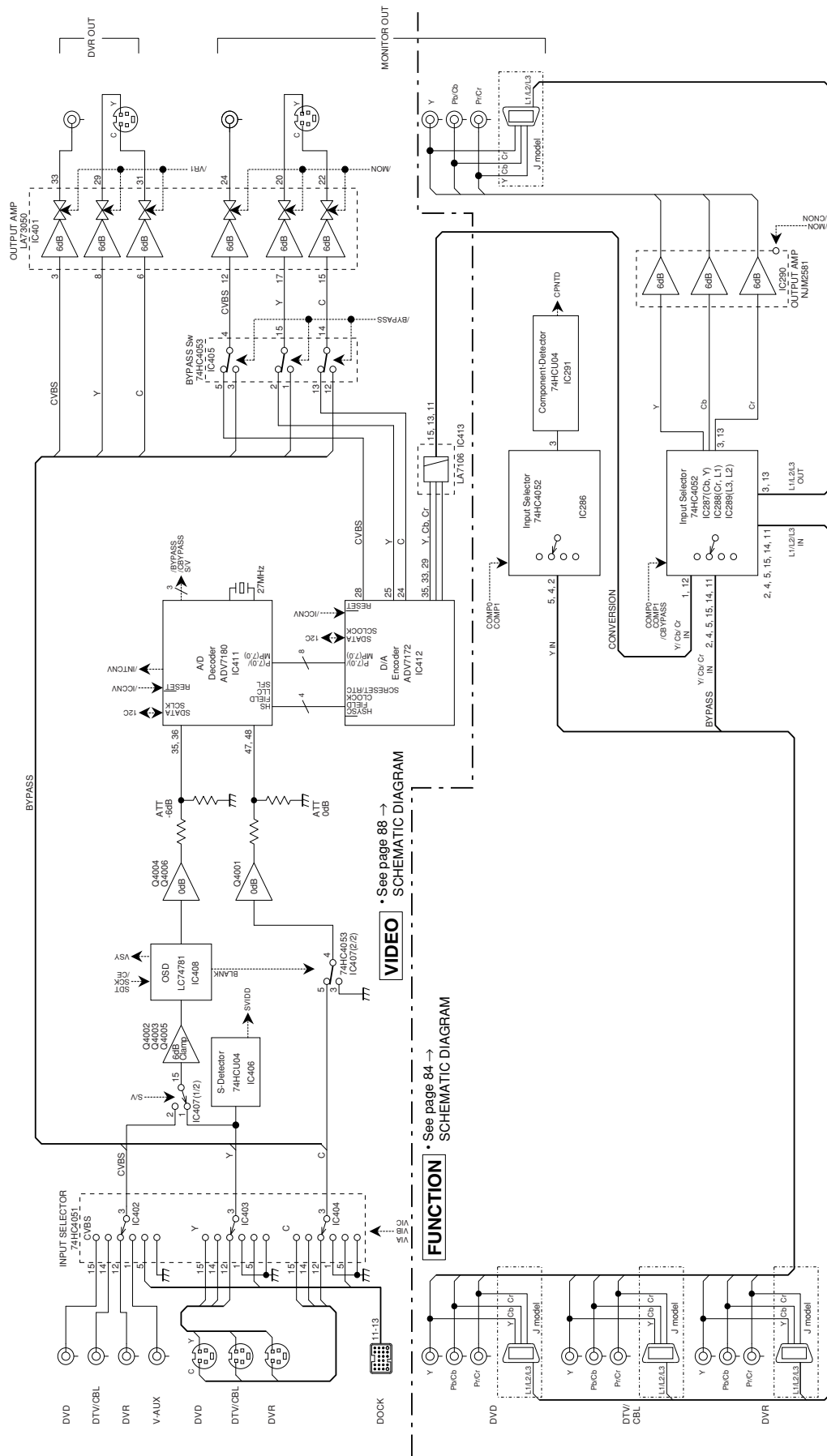

VIDEO SCHEMATIC DIAGRAM

See page 88

FUNCTION SCHEMATIC DIAGRAM

See page 84

A B C D E F G H I J

A B C D E F G H I J

CONTROL/POWER BLOCK DIAGRAM

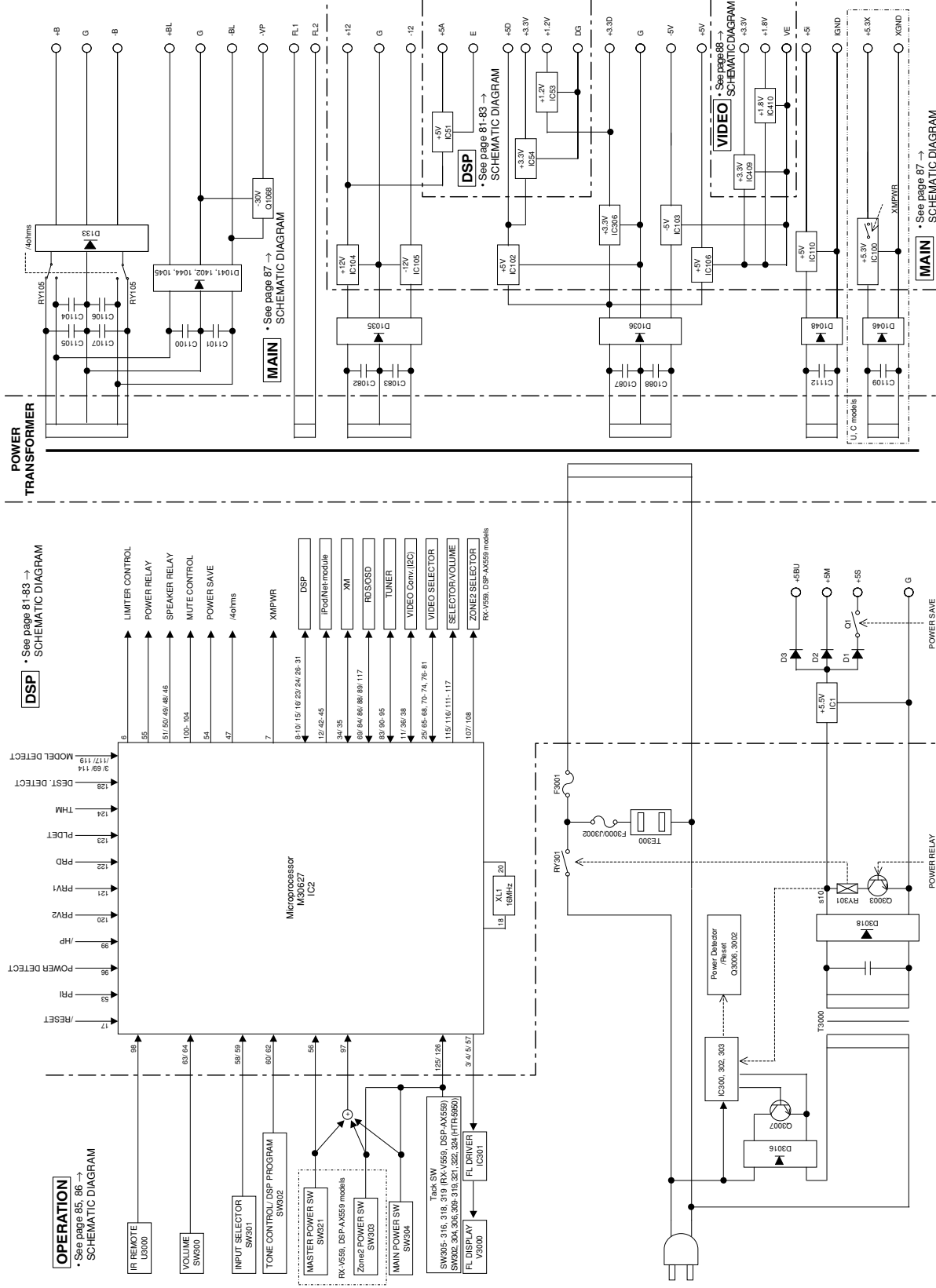

FUNCTION (1) P.C.B. (Side A)

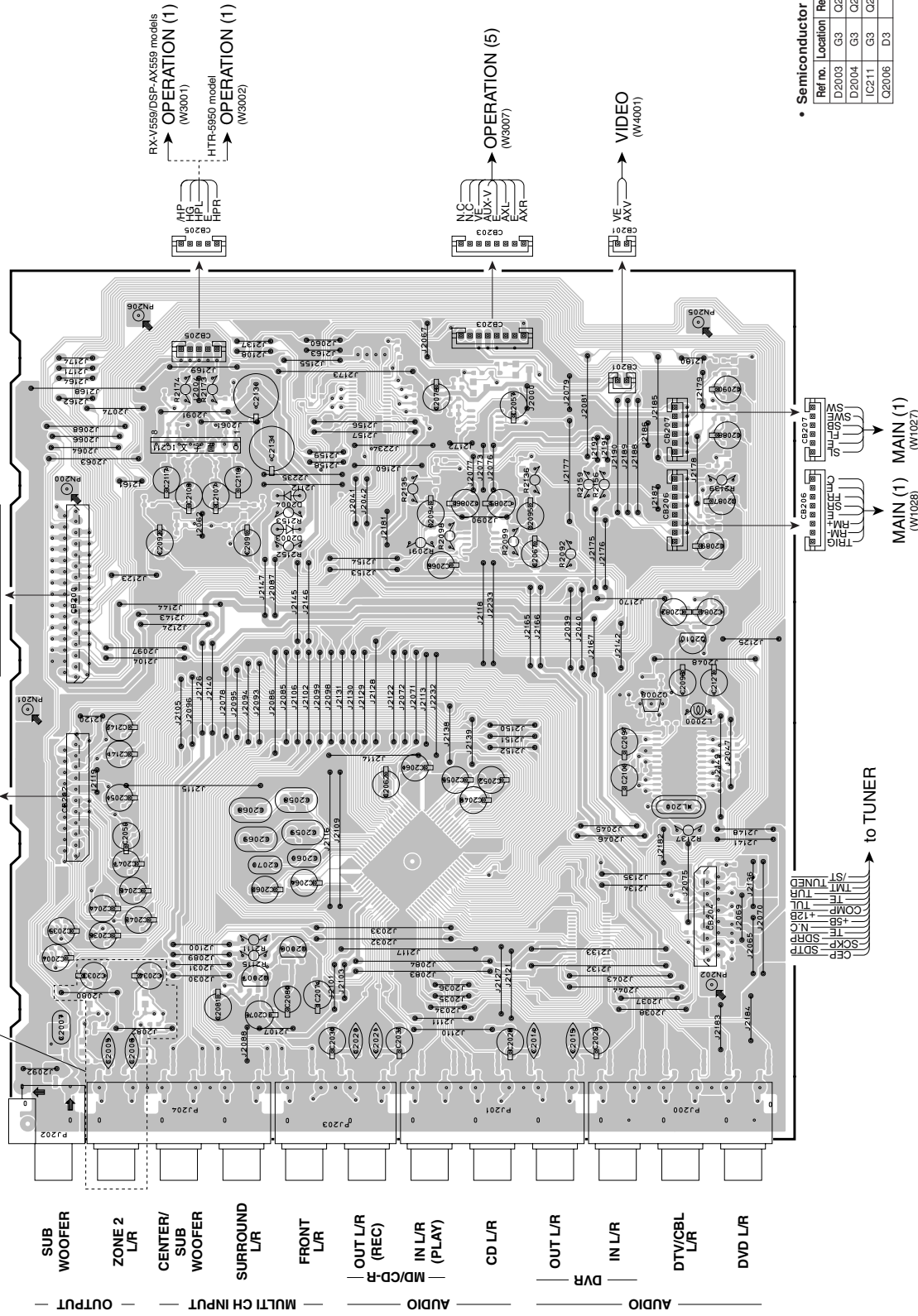

• Semiconductor Location

Ref no.	Location	Ref no.	Location
D2003	G3	Q2007	D3
D2004	G3	Q2008	F6
IC211	G3	Q2010	F6
Q2006	D3		

A B C D E F G H I J

FUNCTION (1) P.C.B. (Side B)

Lead Free Solder Used

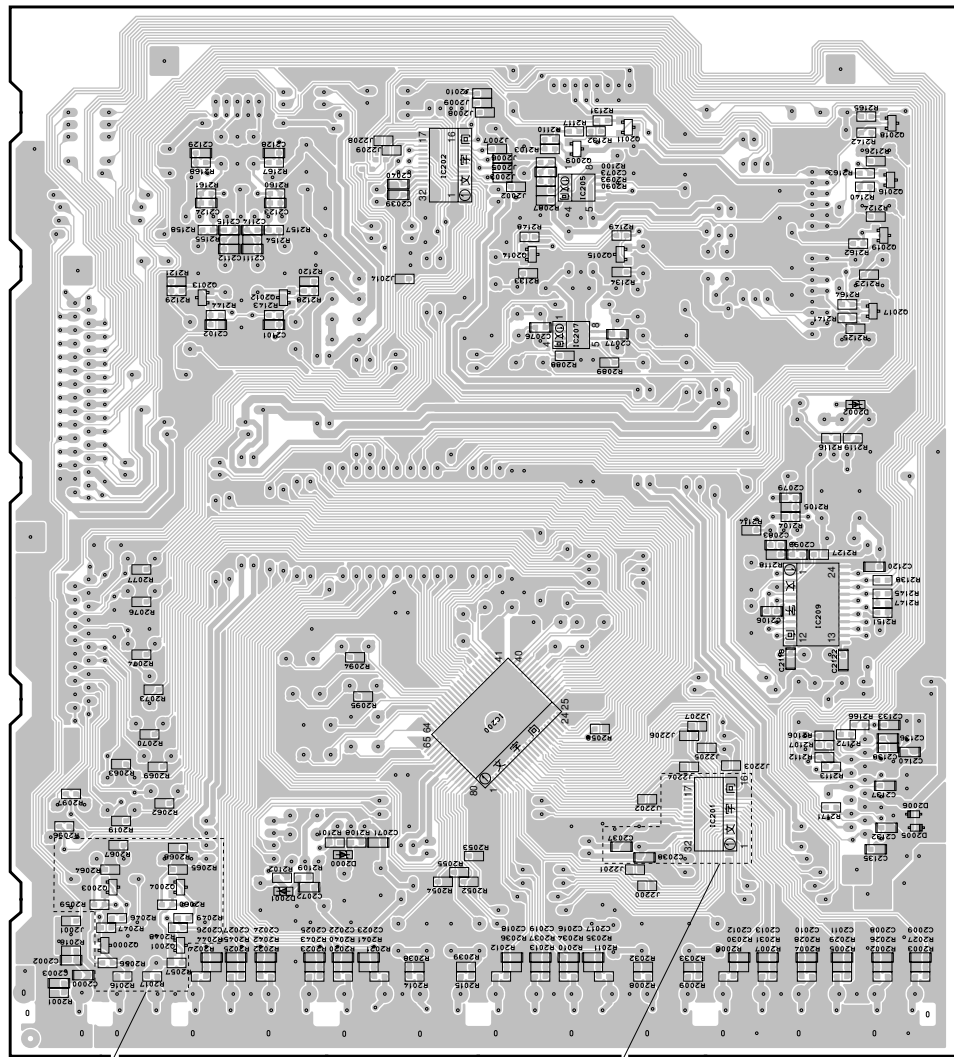

RX-V559/DSP-AX559 models

RX-V559/DSP-AX559 models

• **Semiconductor Location**

Ref no.	Location	Ref no.	Location
D2000	D3	Q2003	D2
D2001	D3	Q2004	D3
D2002	F6	Q2009	G5
D2005	D6	Q2011	H5
D2006	D6	Q2012	G3
IC200	E4	Q2013	G3
IC201	D5	Q2014	G4
IC202	G4	Q2015	G5
IC205	G6	Q2016	G6
IC207	G5	Q2017	G6
IC209	E6	Q2018	H6
Q2000	D2	Q2019	G6
Q2001	D3		

1

2

3

4

5

6

7

FUNCTION (2) P.C.B. (Side B)
Lead Free Solder Used

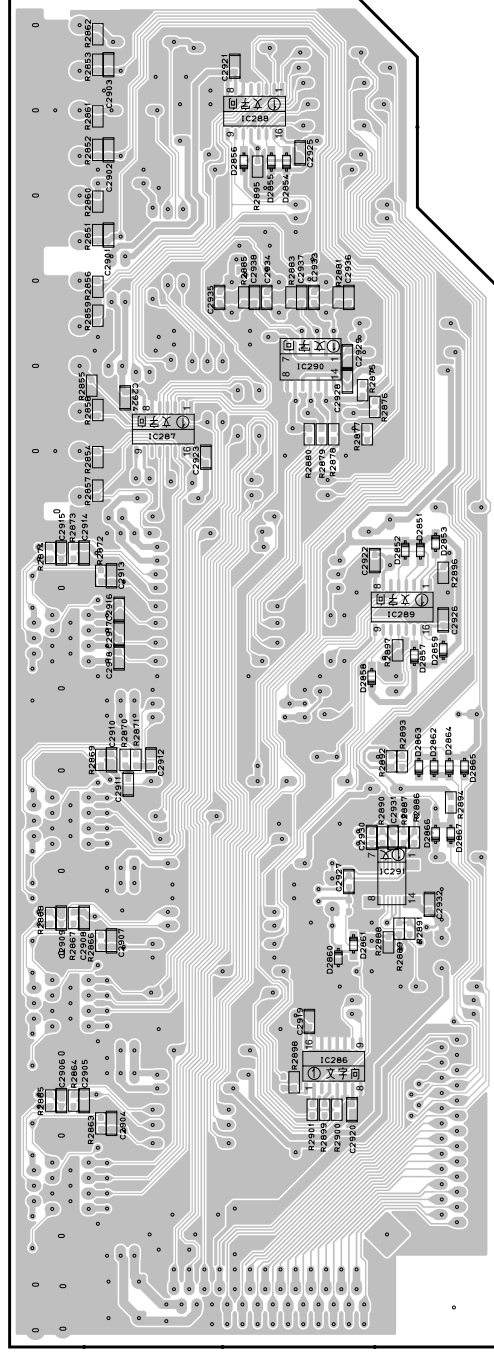

• Semiconductor Location

Ref no.	Location	Ref no.	Location
D2851	F5	D2863	E5
D2852	F5	D2864	E5
D2853	F5	D2865	E5
D2854	H4	D2866	E5
D2855	H4	D2867	E5
D2856	H4	IC286	D5
D2857	F5	IC287	G4
D2858	F5	IC288	H4
D2859	F5	IC289	F5
D2860	D5	IC290	G5
D2861	D5	IC291	E5
D2862	E5		

RX-V559/DSP-AX559

OPERATION (1) P.C.B. (Side A)

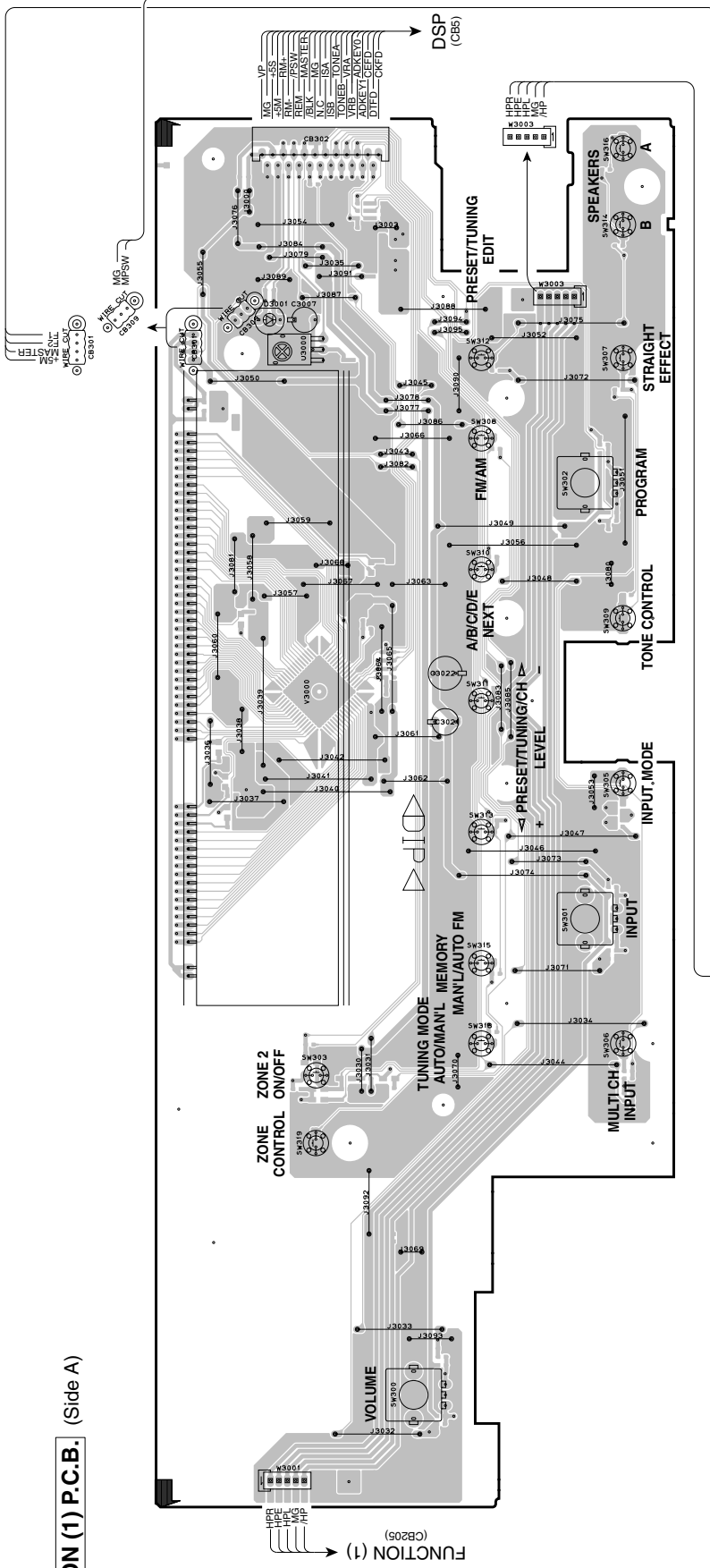

OPERATION (2) P.C.B. (Side A)

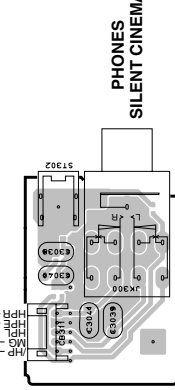
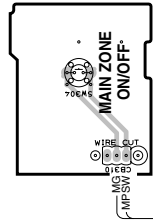

OPERATION (3) P.C.B. (Side A)

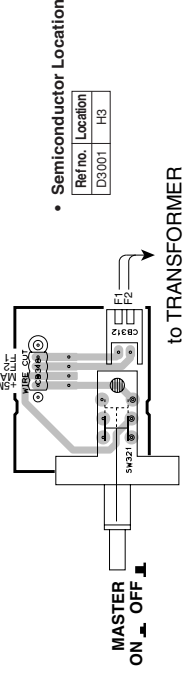

OPERATION (6) P.C.B. (Side A)

- Semiconductor Location
- | Ref no. | Location |
|---------|----------|
| D3001 | H3 |

A B C D E F G H I J

RX-V559/DSP-AX559

OPERATION (1) P.C.B. (Side B)
Lead Free Solder Used

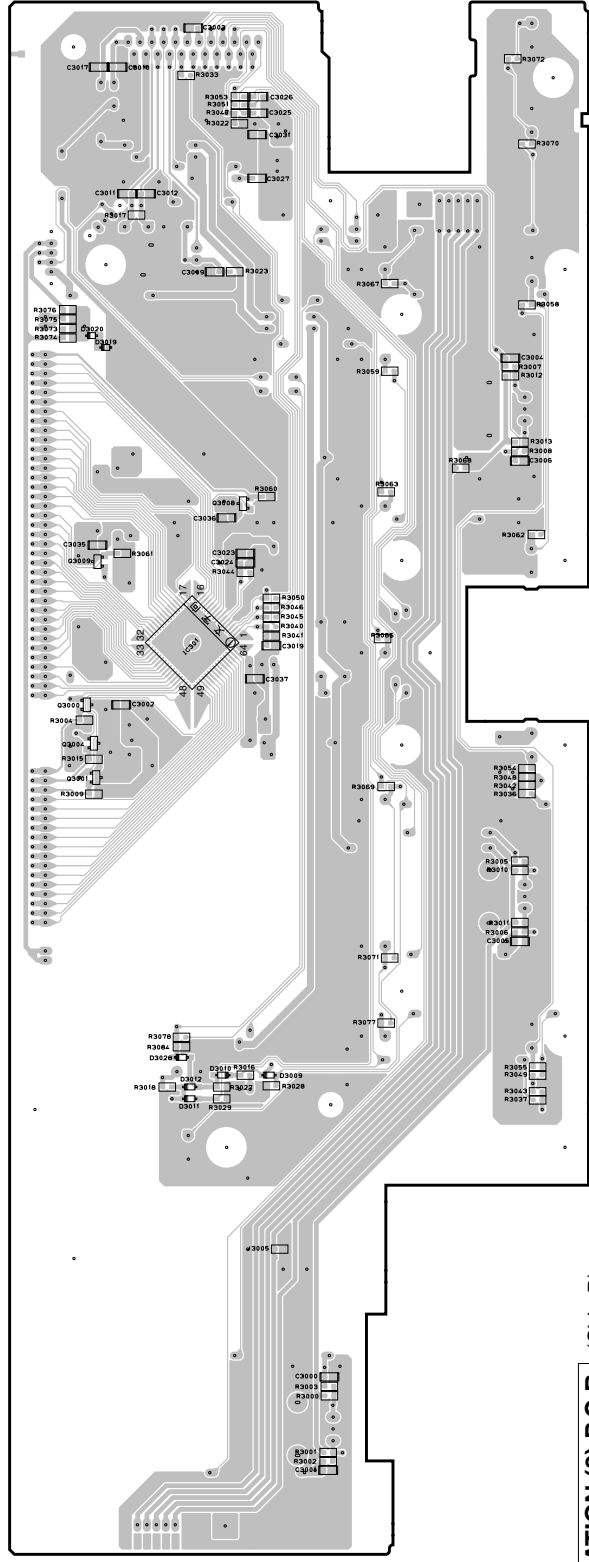

OPERATION (3) P.C.B. (Side B)
Lead Free Solder Used

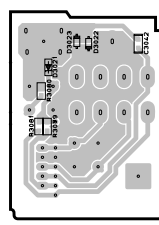

• Semiconductor Location

Ref no.	Location	Ref no.	Location
D3009	D4	D3023	C6
D3010	D3	D3028	D3
D3011	D3	IC301	F3
D3012	D3	Q3000	F3
D3019	H3	Q3001	F3
D3020	H3	Q3004	F3
D3021	G6	Q3008	G3
D3022	C6	Q3009	G3

RX-V559/DSP-AX559

OPERATION (4) P.C.B. (Side B)

Lead Free Solder Used

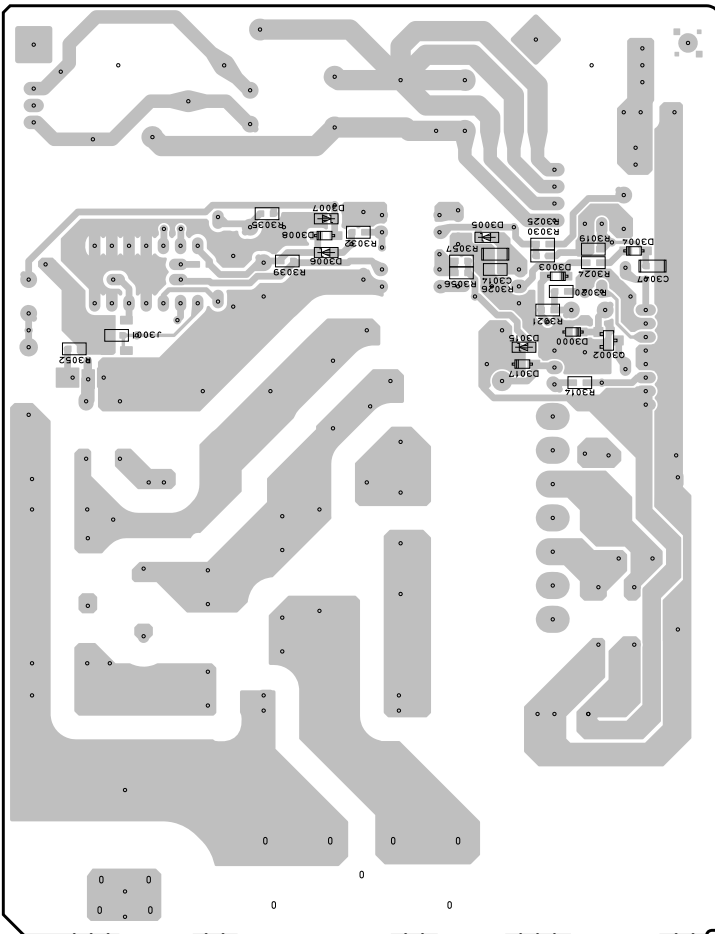

OPERATION (5) P.C.B. (Side B)

Lead Free Solder Used

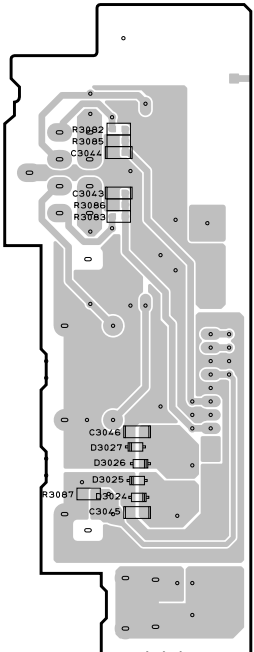

Semiconductor Location

Ref no.	Location	Ref no.	Location
D3000	D5	D3015	D5
D3003	E5	D3017	D5
D3004	E6	D3024	G3
D3005	E5	D3025	G3
D3006	E4	D3026	G3
D3007	E4	D3027	G3
D3008	E4	C3002	D5

HTR-5950

OPERATION (1) P.C.B. (Side A)

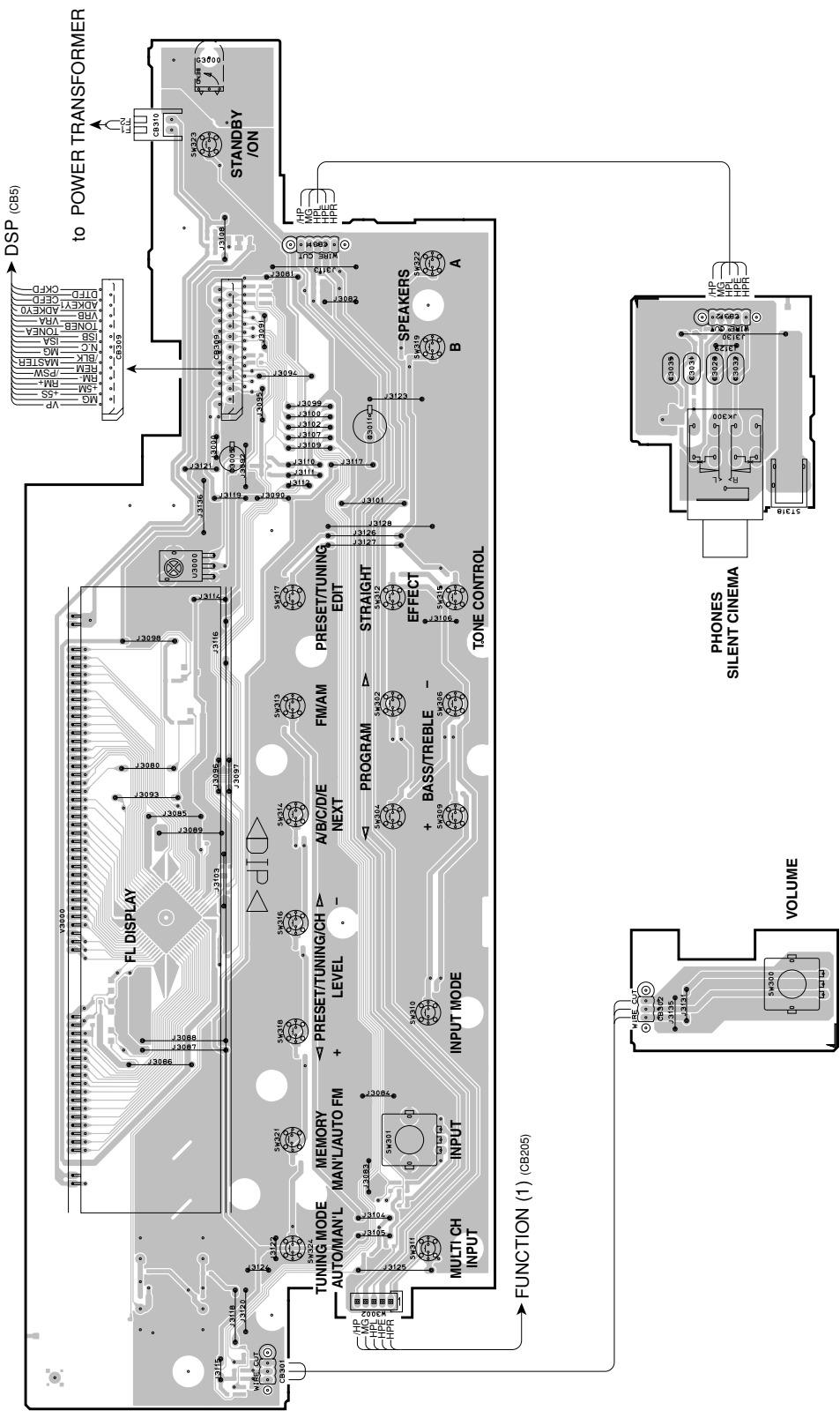

OPERATION (3) P.C.B. (Side A)

OPERATION (6) P.C.B. (Side A)

A B C D E F G H I J

HTR-5950

OPERATION (1) P.C.B. (Side B)

Lead Free Solder Used

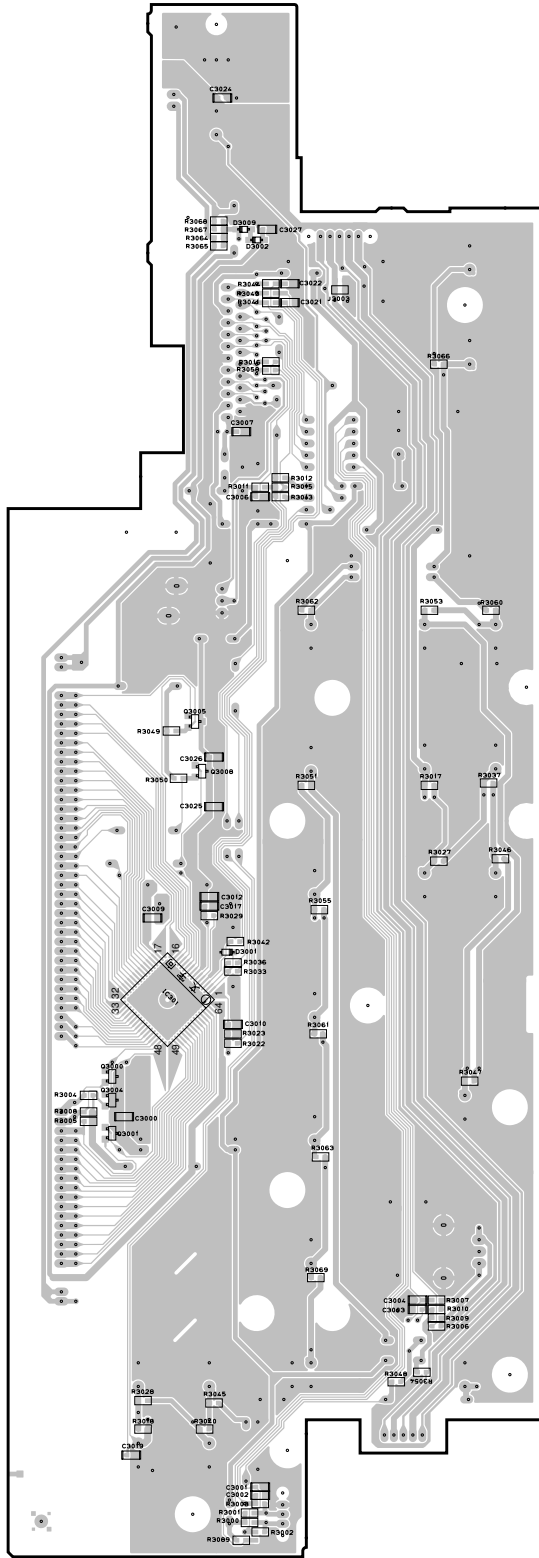

OPERATION (3) P.C.B. (Side B)

Lead Free Solder Used

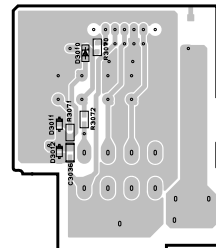

• **Semiconductor Location**

Ref no.	Location	Ref no.	Location
D3001	E3	IC301	D3
D3002	H3	C3000	D2
D3009	H3	Q3001	D2
D3010	C6	C3004	D2
D3011	B6	C3005	F3
D3012	B6	C3008	F3

HTR-5950

OPERATION (4) P.C.B. (Side A)

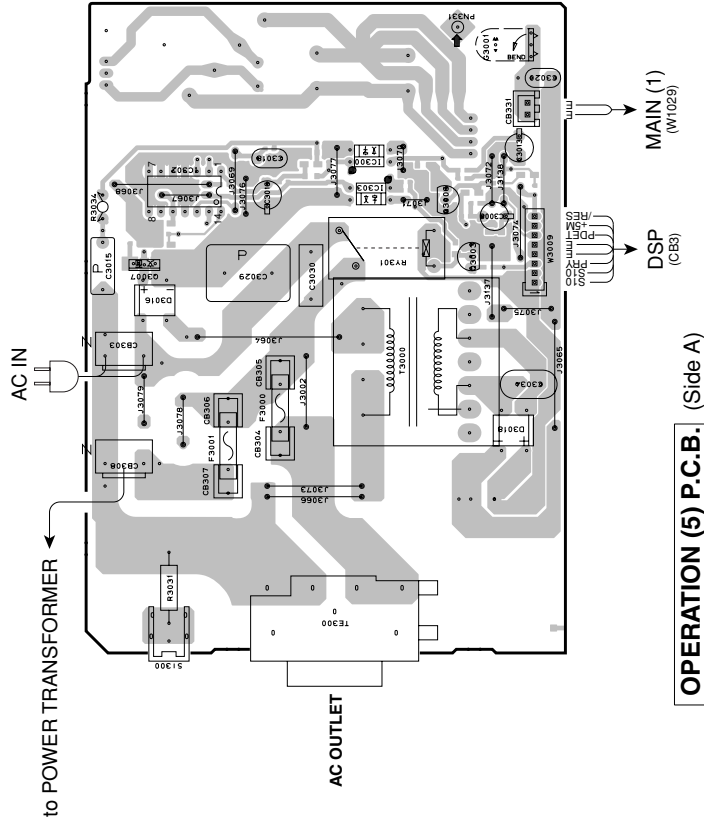

OPERATION (5) P.C.B. (Side A)

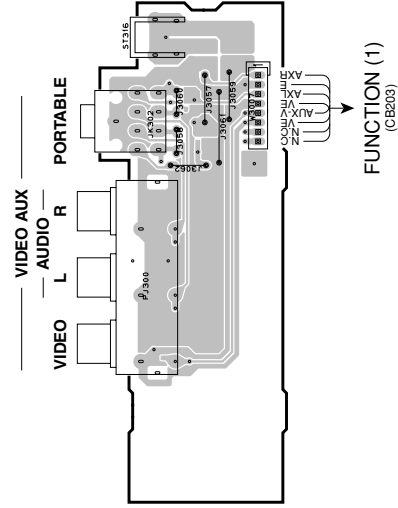

OPERATION (4) P.C.B. (Side B)

Lead Free Solder Used

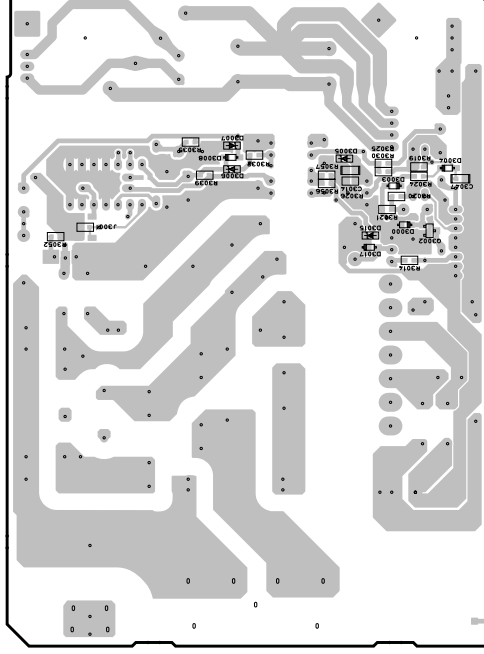

OPERATION (5) P.C.B. (Side B)

Lead Free Solder Used

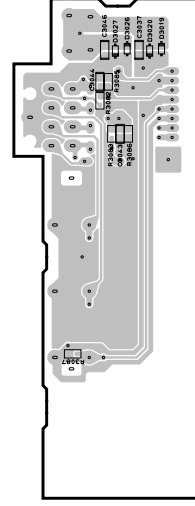

• **Semiconductor Location**

Ref no.	Location	Ref no.	Location
D3000	H4	D3019	I6
D3003	H4	D3020	I6
D3004	I4	D3026	I6
D3005	I4	D3027	I6
D3006	I3	IC300	D3
D3007	I3	IC302	D3
D3008	I3	IC303	D3
D3015	H4	Q3002	H4
D3016	D2	Q3003	D4
D3017	H4	Q3006	D4
D3018	C4	Q3007	D2

A B C D E F G H I J

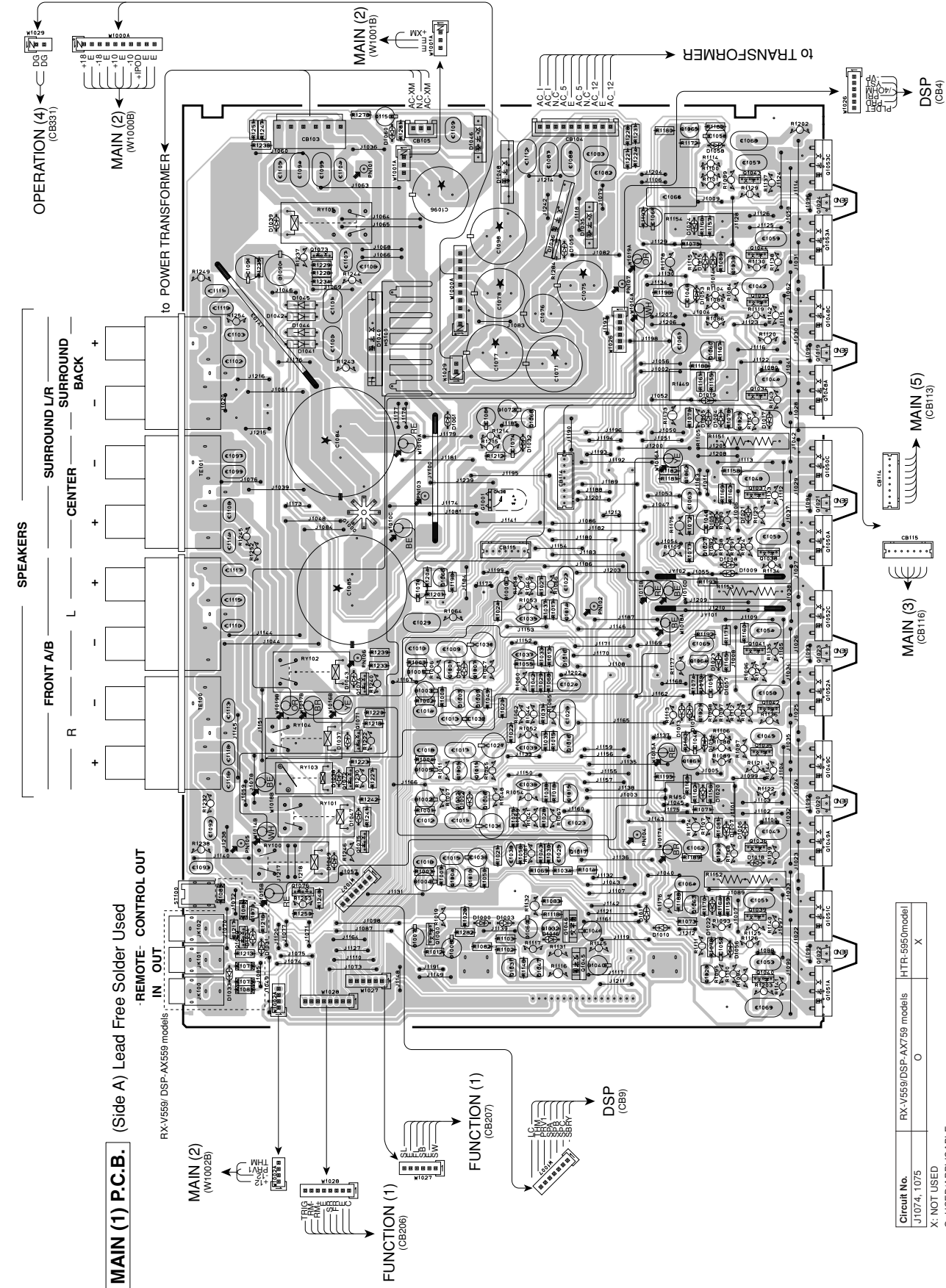

• Semiconductor Location

Ref. no.	Location	Ref. no.	Location
D1000	C4	Q1011	D4
D1001	E4	Q1014	E5
D1002	D4	Q1015	D5
D1003	C4	Q1016	E5
D1004	F6	Q1017	D5
D1005	F6	Q1018	D5
D1006	D6	Q1019	G6
D1007	D6	Q1020	D6
D1008	F6	Q1021	F6
D1009	E6	Q1022	G6
D1010	C5	Q1023	E6
D1011	C5	Q1024	H6
D1012	D5	Q1025	F6
D1013	D5	Q1026	D6
D1014	G6	Q1027	F6
D1015	G6	Q1028	C6
D1016	C5	Q1029	E6
D1017	F6	Q1030	G6
D1018	D6	Q1031	C4
D1019	G6	Q1032	C5
D1020	D6	Q1033	G6
D1021	F6	Q1034	G6
D1022	C6	Q1035	D6
D1023	H6	Q1036	F6
D1024	E6	Q1037	F6
D1031	C3	Q1038	F6
D1032	F4	Q1039	C6
D1033	C2	Q1040	C6
D1034	C3	Q1041	E6
D1035	H5	Q1042	E6
D1036	H5	Q1043	H6
D1037	D3	Q1044	H6
D1038	D3	Q1045	C5
D1039	H3	Q1046	C5
D1040	G3	Q1047	C4
D1041	G3	Q1048A	G6
D1042	G3	Q1048C	G6
D1043	E3	Q1049A	D6
D1044	G3	Q1049C	D6
D1045	G3	Q1050A	F6
D1046	H4	Q1050C	F6
D1047	D3	Q1051A	C6
D1048	H4	Q1051C	C6
D1049	D3	Q1052A	E6
D1050	H5	Q1052C	E6
D1053	G6	Q1053A	H6
D1054	D6	Q1053C	H6
D1055	F6	Q1060	G6
D1056	C6	Q1061	D5
D1057	E6	Q1062	F5
D1058	H6	Q1063	C5
D1060	H3	Q1064	H5
D1061	F4	Q1065	H5
Q1000	C4	Q1066	E4
Q1001	E4	Q1068	F4
Q1002	D4	Q1069	C2
Q1003	E4	Q1070	C3
Q1004	C4	Q1071	D3
Q1005	D4	Q1072	D3
Q1007	E4	Q1073	H3
Q1008	D4	Q1074	E3
Q1009	E4	Q1075	D3
Q1010	C4	Q1076	C3

Circuit No.	RX-V559/DSP-AX759 models	HTR-5950model
J1074, 1075	O	X

X: NOT USED
O: USED/APPLICABLE

MAIN (2) P.C.B. (Side A) Lead Free Solder Used

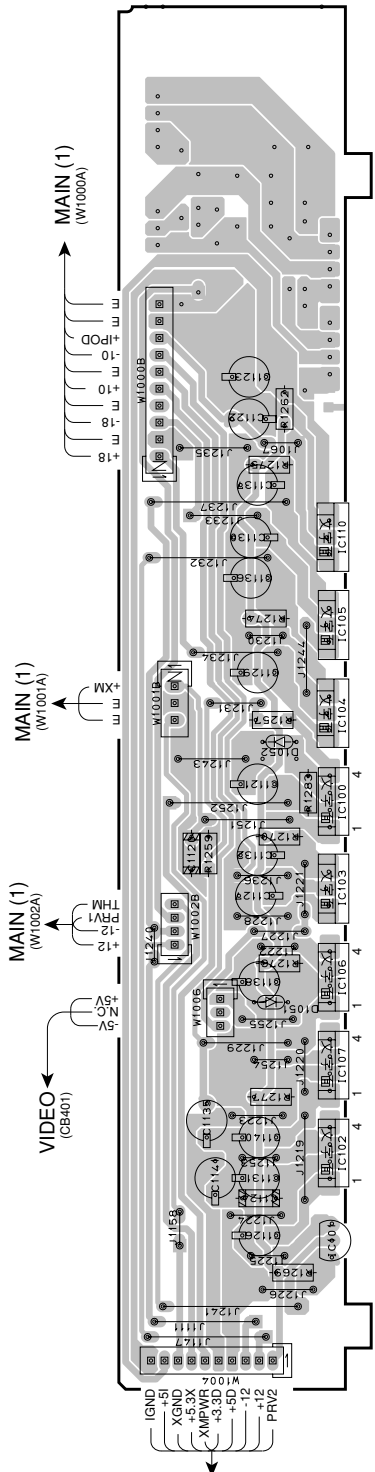

MAIN (4) P.C.B. (Side A) Lead Free Solder Used

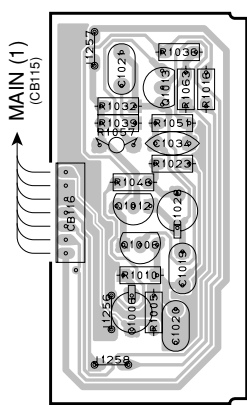

MAIN (5) P.C.B. (Side A) Lead Free Solder Used

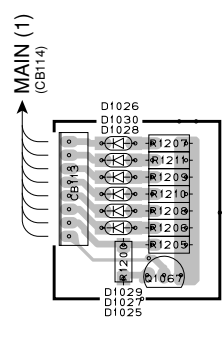

• Semiconductor Location

Ref no.	Location	Ref no.	Location
D1025	G5	IC103	E4
D1026	H5	IC104	F4
D1027	H5	IC105	F4
D1028	H5	IC106	E4
D1029	H5	IC107	D4
D1030	H5	IC110	G4
D1051	D3	Q1006	D5
D1052	F4	Q1012	D5
IC100	E4	Q1013	D5
IC101	C4	Q1067	G6
IC102	D4		

A B C D E F G H I J

VIDEO P.C.B. (Side A)
Lead Free Solder Used

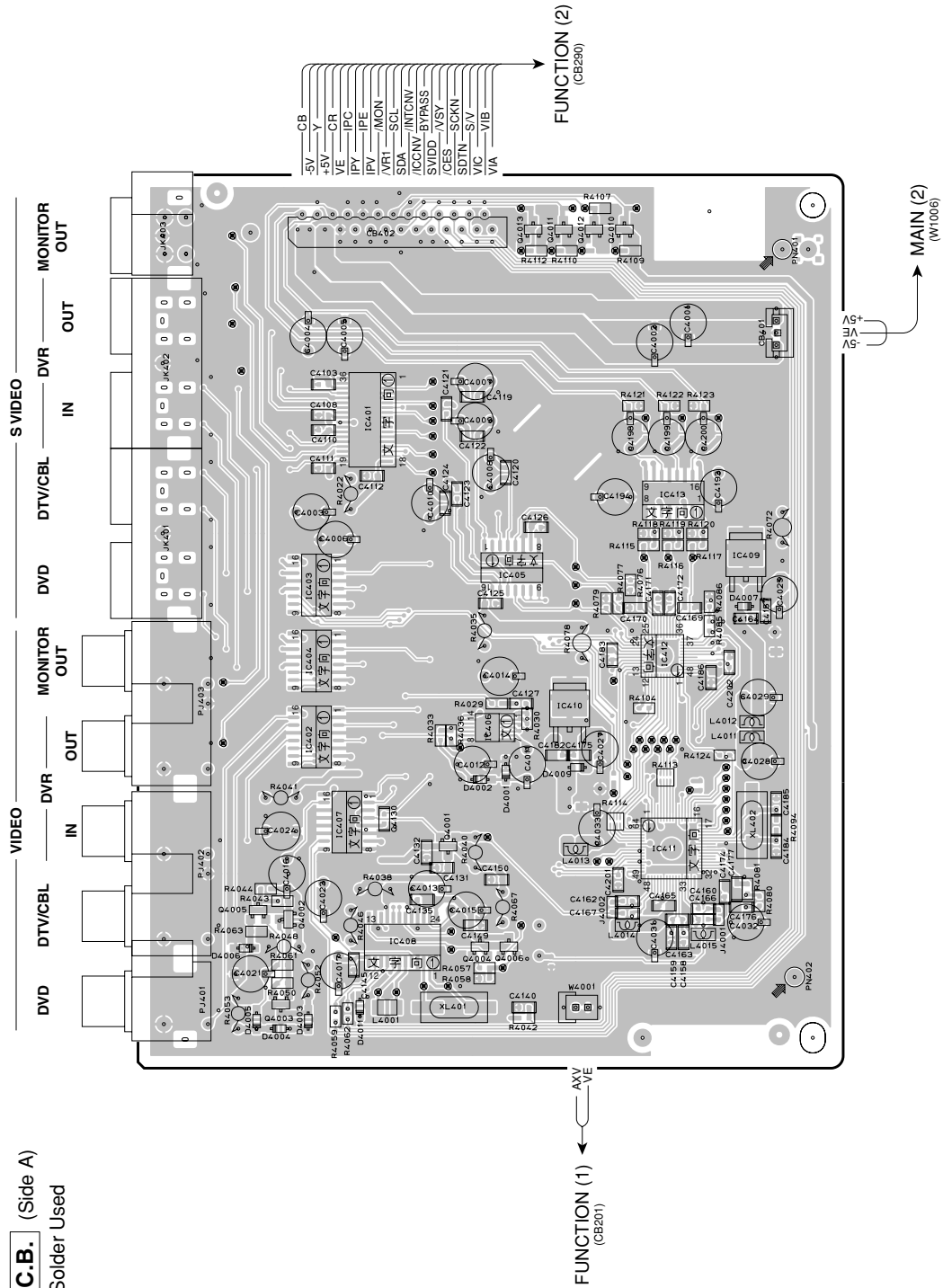

• **Semiconductor Location**

Ref no.	Location	Ref no.	Location
D4001	E4	IC408	D4
D4002	E4	IC409	F6
D4003	C3	IC410	E5
D4004	C3	IC411	D5
D4005	C3	IC412	E5
D4006	F3	IC413	F5
D4007	F6	IC401	D4
D4009	E5	IC402	D3
D4011	C4	IC403	C3
IC402	E3	IC404	D4
IC403	F3	IC405	D3
IC404	E3	IC406	D4
IC405	F4	IC407	H5
IC406	E4	IC408	H5
IC407	D3	IC409	H5

VIDEO P.C.B. (Side B)
Lead Free Solder Used

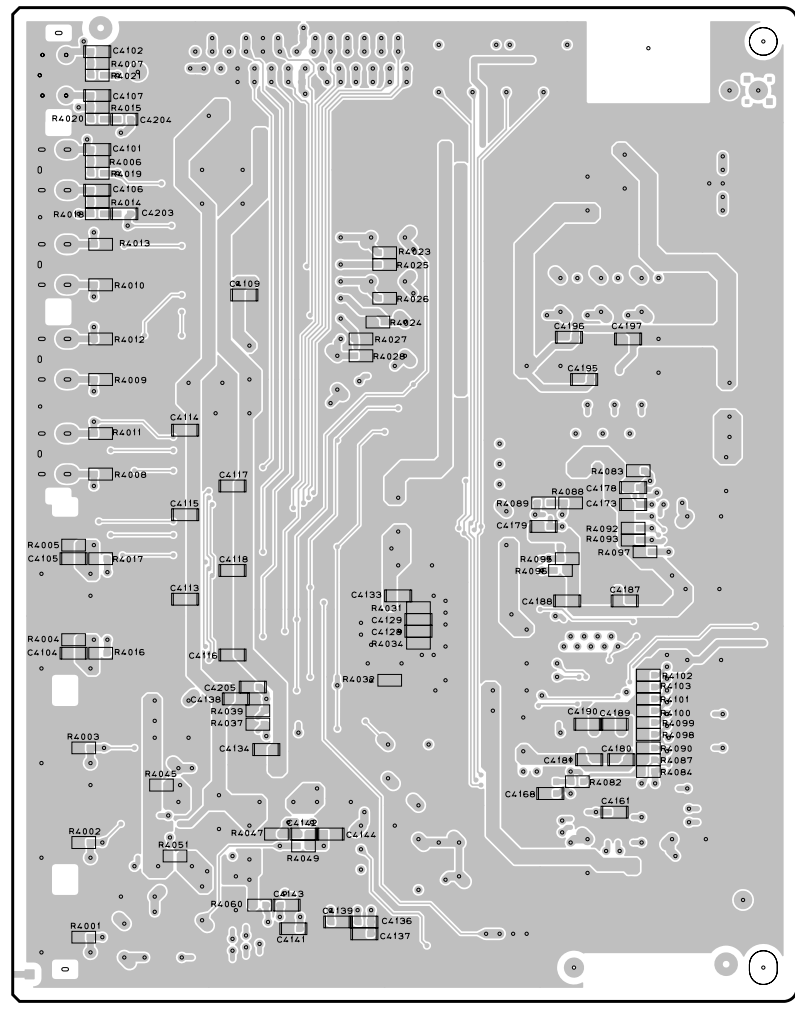

SCHEMATIC DIAGRAMS
DSP 1/3

DSP

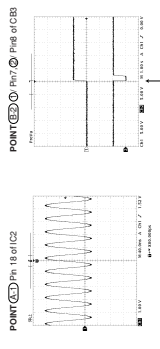
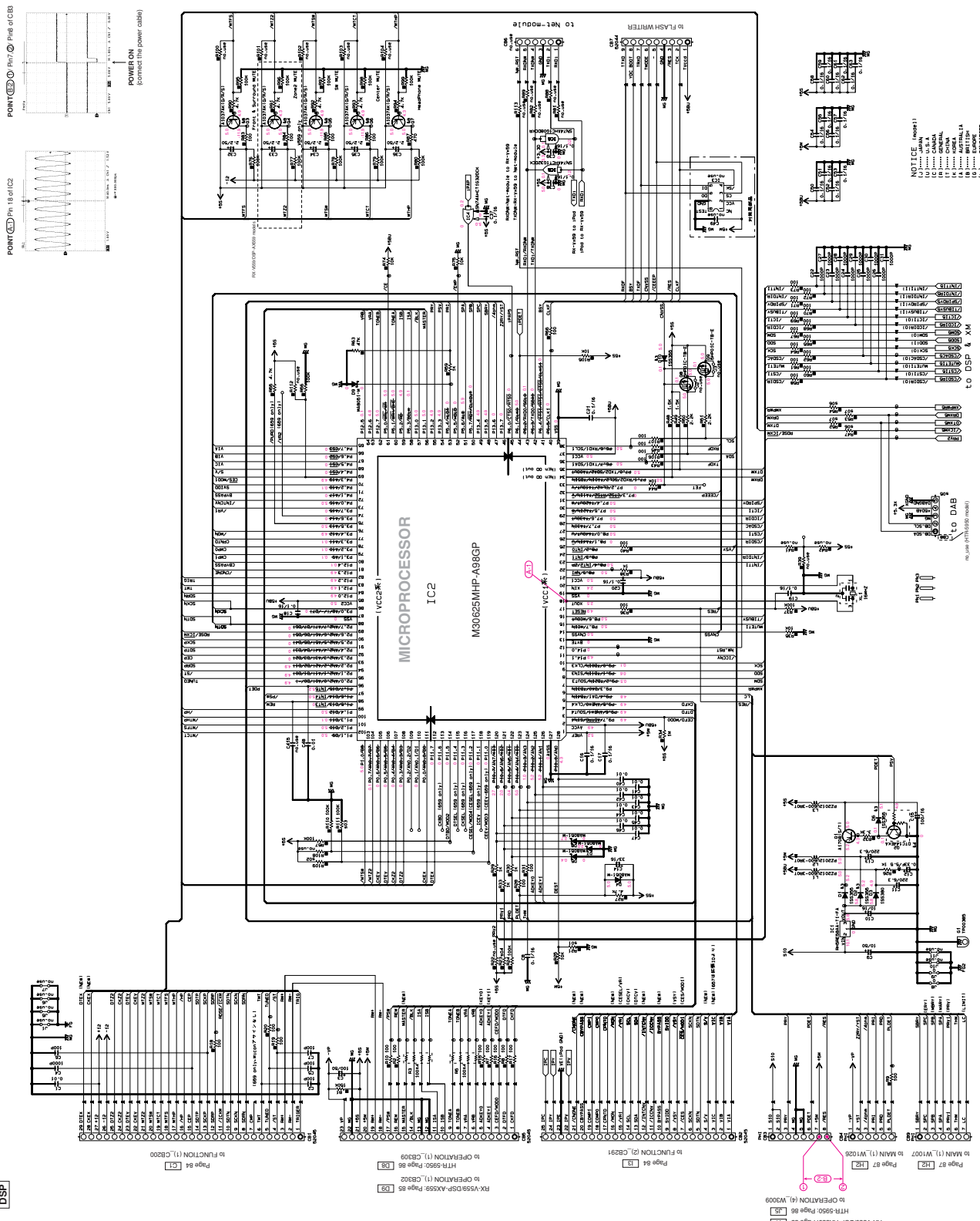

POWER ON (connect the power cable)

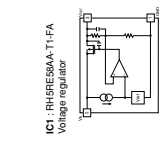

IC1: RH5958AA-T1-FA
Voltage regulator

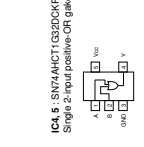

IC3: SN74AHC08BDRR
2-input positive AND gate

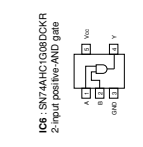

IC4: M30025MHP-A98GP
2-input positive AND gate

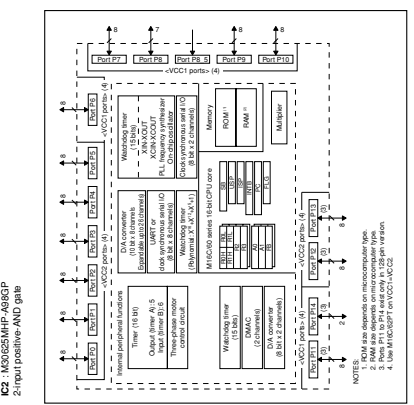

IC2: M30025MHP-A98GP
2-input positive AND gate

- NOTE (IC2: pins 1)
- A GND
 - B GND
 - C GND
 - D GND
 - E GND
 - F GND
 - G GND
 - H GND
 - I GND
 - J GND
 - K GND
 - L GND
 - M GND
 - N GND
 - O GND
 - P GND
 - Q GND
 - R GND
 - S GND
 - T GND
 - U GND
 - V GND
 - W GND
 - X GND
 - Y GND
 - Z GND

* All voltages are measured with a 10MΩ VDC electronic volt meter.
 * Components having special characteristics are marked with a star.
 * Schematic diagram is subject to change without notice.

DSP 2/3

DSP

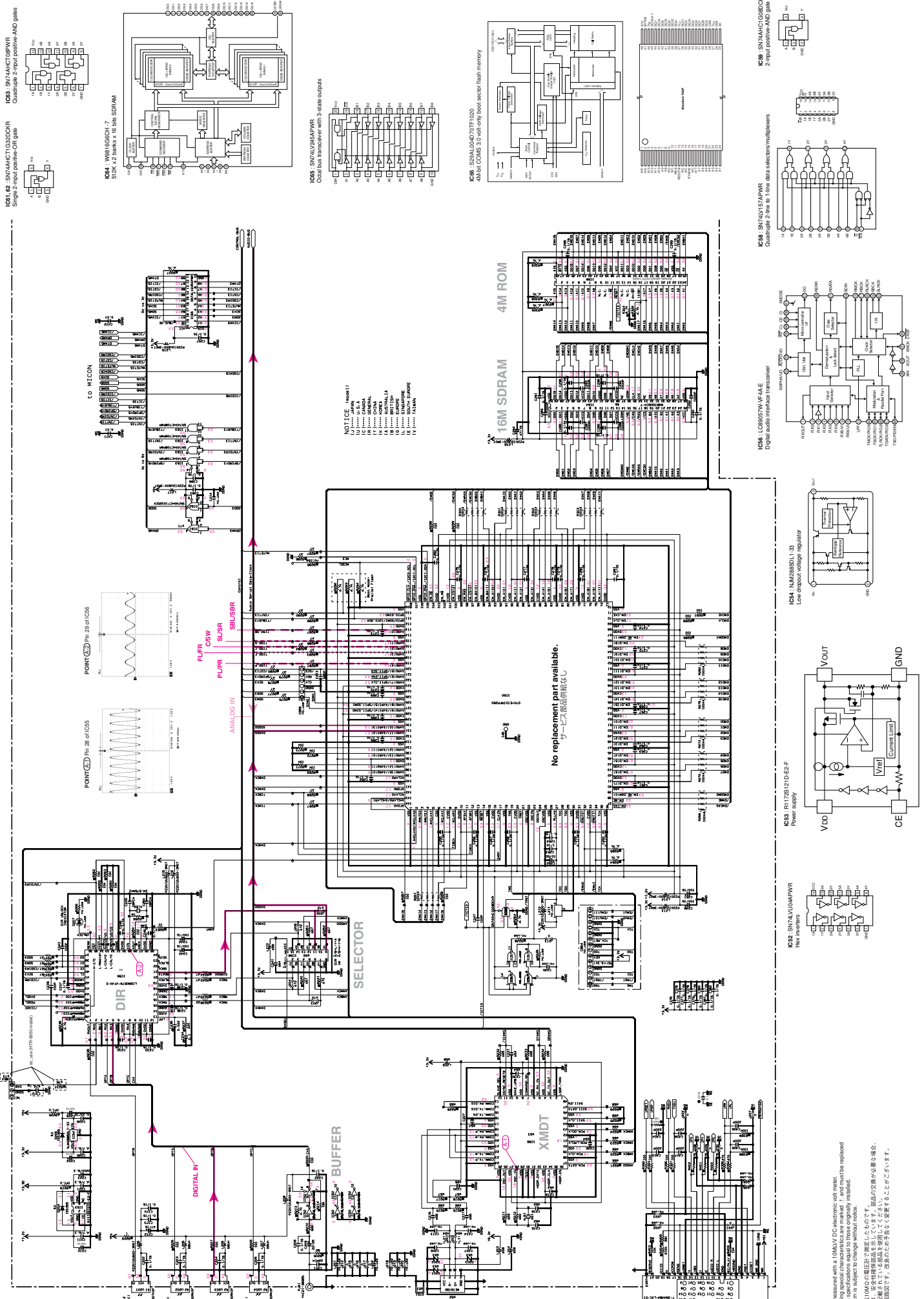

NOTICE (重要)!

① 部品名は必ず確認してください。
 ② 部品名は必ず確認してください。
 ③ 部品名は必ず確認してください。
 ④ 部品名は必ず確認してください。
 ⑤ 部品名は必ず確認してください。
 ⑥ 部品名は必ず確認してください。
 ⑦ 部品名は必ず確認してください。
 ⑧ 部品名は必ず確認してください。

No replacement part available.
 代替部品供給なし

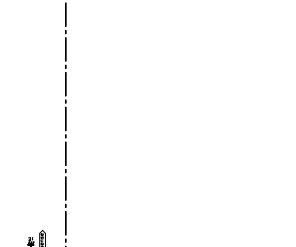
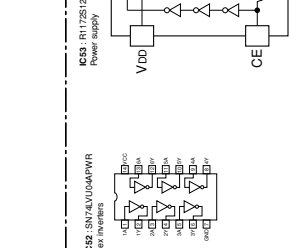
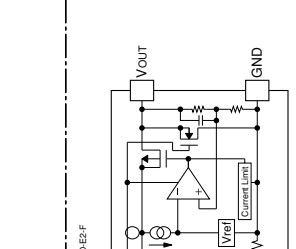
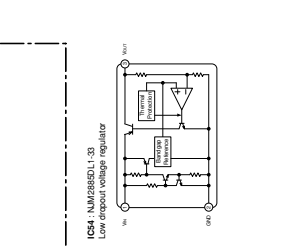
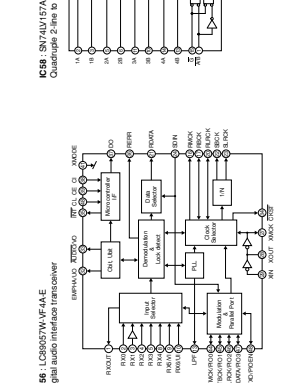
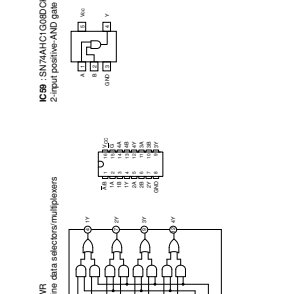
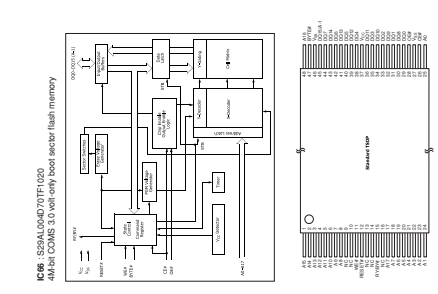
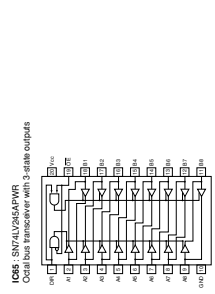
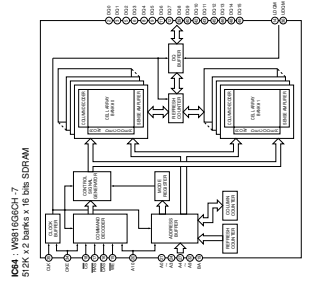
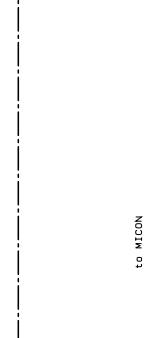
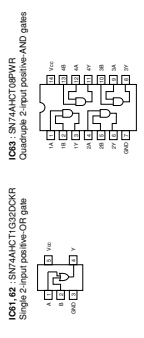

* All voltages are measured with a 10MΩ DC electronic volt meter.
 * Component having special characters for marking is and must be replaced.
 * Schematic diagram is subject to change without notice.
 ● 電圧は、10MΩの電圧計で測定したものです。
 ● 1印のある部品は、特別な印記を付している場合があります。部品の交換がなされる場合、
 ● 1印のない部品は、特別な印記を付している場合があります。部品の交換がなされる場合、
 ● 本図面は予告なく変更される場合があります。

Page 84 of 122
FUNCTION 11, CB02
10 MAIN(2), VTI04

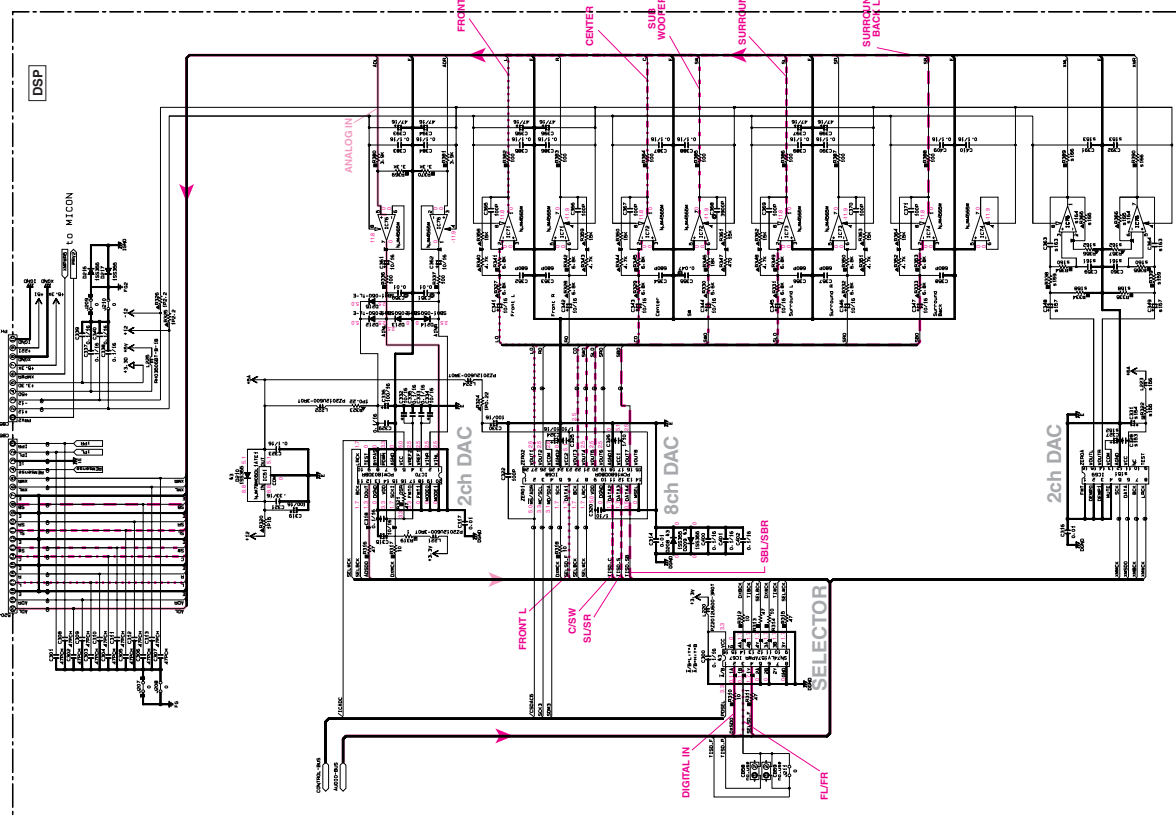

NOTICE (page 11)

RESISTOR

1	RESISTOR
2	RESISTOR
3	RESISTOR
4	RESISTOR
5	RESISTOR
6	RESISTOR
7	RESISTOR
8	RESISTOR
9	RESISTOR
10	RESISTOR
11	RESISTOR
12	RESISTOR
13	RESISTOR
14	RESISTOR
15	RESISTOR
16	RESISTOR
17	RESISTOR
18	RESISTOR
19	RESISTOR
20	RESISTOR
21	RESISTOR
22	RESISTOR
23	RESISTOR
24	RESISTOR
25	RESISTOR
26	RESISTOR
27	RESISTOR
28	RESISTOR
29	RESISTOR
30	RESISTOR
31	RESISTOR
32	RESISTOR
33	RESISTOR
34	RESISTOR
35	RESISTOR
36	RESISTOR
37	RESISTOR
38	RESISTOR
39	RESISTOR
40	RESISTOR
41	RESISTOR
42	RESISTOR
43	RESISTOR
44	RESISTOR
45	RESISTOR
46	RESISTOR
47	RESISTOR
48	RESISTOR
49	RESISTOR
50	RESISTOR
51	RESISTOR
52	RESISTOR
53	RESISTOR
54	RESISTOR
55	RESISTOR
56	RESISTOR
57	RESISTOR
58	RESISTOR
59	RESISTOR
60	RESISTOR
61	RESISTOR
62	RESISTOR
63	RESISTOR
64	RESISTOR
65	RESISTOR
66	RESISTOR
67	RESISTOR
68	RESISTOR
69	RESISTOR
70	RESISTOR
71	RESISTOR
72	RESISTOR
73	RESISTOR
74	RESISTOR
75	RESISTOR
76	RESISTOR
77	RESISTOR
78	RESISTOR
79	RESISTOR
80	RESISTOR
81	RESISTOR
82	RESISTOR
83	RESISTOR
84	RESISTOR
85	RESISTOR
86	RESISTOR
87	RESISTOR
88	RESISTOR
89	RESISTOR
90	RESISTOR
91	RESISTOR
92	RESISTOR
93	RESISTOR
94	RESISTOR
95	RESISTOR
96	RESISTOR
97	RESISTOR
98	RESISTOR
99	RESISTOR
100	RESISTOR

RESISTOR	VALUE	TYPE	TEMPERATURE COEFFICIENT	POWER RATING	REMARKS
R1	10K	1/4W	±1%	0.25W	RESISTOR
R2	10K	1/4W	±1%	0.25W	RESISTOR
R3	10K	1/4W	±1%	0.25W	RESISTOR
R4	10K	1/4W	±1%	0.25W	RESISTOR
R5	10K	1/4W	±1%	0.25W	RESISTOR
R6	10K	1/4W	±1%	0.25W	RESISTOR
R7	10K	1/4W	±1%	0.25W	RESISTOR
R8	10K	1/4W	±1%	0.25W	RESISTOR
R9	10K	1/4W	±1%	0.25W	RESISTOR
R10	10K	1/4W	±1%	0.25W	RESISTOR
R11	10K	1/4W	±1%	0.25W	RESISTOR
R12	10K	1/4W	±1%	0.25W	RESISTOR
R13	10K	1/4W	±1%	0.25W	RESISTOR
R14	10K	1/4W	±1%	0.25W	RESISTOR
R15	10K	1/4W	±1%	0.25W	RESISTOR
R16	10K	1/4W	±1%	0.25W	RESISTOR
R17	10K	1/4W	±1%	0.25W	RESISTOR
R18	10K	1/4W	±1%	0.25W	RESISTOR
R19	10K	1/4W	±1%	0.25W	RESISTOR
R20	10K	1/4W	±1%	0.25W	RESISTOR
R21	10K	1/4W	±1%	0.25W	RESISTOR
R22	10K	1/4W	±1%	0.25W	RESISTOR
R23	10K	1/4W	±1%	0.25W	RESISTOR
R24	10K	1/4W	±1%	0.25W	RESISTOR
R25	10K	1/4W	±1%	0.25W	RESISTOR
R26	10K	1/4W	±1%	0.25W	RESISTOR
R27	10K	1/4W	±1%	0.25W	RESISTOR
R28	10K	1/4W	±1%	0.25W	RESISTOR
R29	10K	1/4W	±1%	0.25W	RESISTOR
R30	10K	1/4W	±1%	0.25W	RESISTOR
R31	10K	1/4W	±1%	0.25W	RESISTOR
R32	10K	1/4W	±1%	0.25W	RESISTOR
R33	10K	1/4W	±1%	0.25W	RESISTOR
R34	10K	1/4W	±1%	0.25W	RESISTOR
R35	10K	1/4W	±1%	0.25W	RESISTOR
R36	10K	1/4W	±1%	0.25W	RESISTOR
R37	10K	1/4W	±1%	0.25W	RESISTOR
R38	10K	1/4W	±1%	0.25W	RESISTOR
R39	10K	1/4W	±1%	0.25W	RESISTOR
R40	10K	1/4W	±1%	0.25W	RESISTOR
R41	10K	1/4W	±1%	0.25W	RESISTOR
R42	10K	1/4W	±1%	0.25W	RESISTOR
R43	10K	1/4W	±1%	0.25W	RESISTOR
R44	10K	1/4W	±1%	0.25W	RESISTOR
R45	10K	1/4W	±1%	0.25W	RESISTOR
R46	10K	1/4W	±1%	0.25W	RESISTOR
R47	10K	1/4W	±1%	0.25W	RESISTOR
R48	10K	1/4W	±1%	0.25W	RESISTOR
R49	10K	1/4W	±1%	0.25W	RESISTOR
R50	10K	1/4W	±1%	0.25W	RESISTOR
R51	10K	1/4W	±1%	0.25W	RESISTOR
R52	10K	1/4W	±1%	0.25W	RESISTOR
R53	10K	1/4W	±1%	0.25W	RESISTOR
R54	10K	1/4W	±1%	0.25W	RESISTOR
R55	10K	1/4W	±1%	0.25W	RESISTOR
R56	10K	1/4W	±1%	0.25W	RESISTOR
R57	10K	1/4W	±1%	0.25W	RESISTOR
R58	10K	1/4W	±1%	0.25W	RESISTOR
R59	10K	1/4W	±1%	0.25W	RESISTOR
R60	10K	1/4W	±1%	0.25W	RESISTOR
R61	10K	1/4W	±1%	0.25W	RESISTOR
R62	10K	1/4W	±1%	0.25W	RESISTOR
R63	10K	1/4W	±1%	0.25W	RESISTOR
R64	10K	1/4W	±1%	0.25W	RESISTOR
R65	10K	1/4W	±1%	0.25W	RESISTOR
R66	10K	1/4W	±1%	0.25W	RESISTOR
R67	10K	1/4W	±1%	0.25W	RESISTOR
R68	10K	1/4W	±1%	0.25W	RESISTOR
R69	10K	1/4W	±1%	0.25W	RESISTOR
R70	10K	1/4W	±1%	0.25W	RESISTOR
R71	10K	1/4W	±1%	0.25W	RESISTOR
R72	10K	1/4W	±1%	0.25W	RESISTOR
R73	10K	1/4W	±1%	0.25W	RESISTOR
R74	10K	1/4W	±1%	0.25W	RESISTOR
R75	10K	1/4W	±1%	0.25W	RESISTOR
R76	10K	1/4W	±1%	0.25W	RESISTOR
R77	10K	1/4W	±1%	0.25W	RESISTOR
R78	10K	1/4W	±1%	0.25W	RESISTOR
R79	10K	1/4W	±1%	0.25W	RESISTOR
R80	10K	1/4W	±1%	0.25W	RESISTOR
R81	10K	1/4W	±1%	0.25W	RESISTOR
R82	10K	1/4W	±1%	0.25W	RESISTOR
R83	10K	1/4W	±1%	0.25W	RESISTOR
R84	10K	1/4W	±1%	0.25W	RESISTOR
R85	10K	1/4W	±1%	0.25W	RESISTOR
R86	10K	1/4W	±1%	0.25W	RESISTOR
R87	10K	1/4W	±1%	0.25W	RESISTOR
R88	10K	1/4W	±1%	0.25W	RESISTOR
R89	10K	1/4W	±1%	0.25W	RESISTOR
R90	10K	1/4W	±1%	0.25W	RESISTOR
R91	10K	1/4W	±1%	0.25W	RESISTOR
R92	10K	1/4W	±1%	0.25W	RESISTOR
R93	10K	1/4W	±1%	0.25W	RESISTOR
R94	10K	1/4W	±1%	0.25W	RESISTOR
R95	10K	1/4W	±1%	0.25W	RESISTOR
R96	10K	1/4W	±1%	0.25W	RESISTOR
R97	10K	1/4W	±1%	0.25W	RESISTOR
R98	10K	1/4W	±1%	0.25W	RESISTOR
R99	10K	1/4W	±1%	0.25W	RESISTOR
R100	10K	1/4W	±1%	0.25W	RESISTOR

IC7174, 75, 76: NJM4558M
Dual operational amplifier

1	RESISTOR
2	RESISTOR
3	RESISTOR
4	RESISTOR
5	RESISTOR
6	RESISTOR
7	RESISTOR
8	RESISTOR
9	RESISTOR
10	RESISTOR
11	RESISTOR
12	RESISTOR
13	RESISTOR
14	RESISTOR
15	RESISTOR
16	RESISTOR
17	RESISTOR
18	RESISTOR
19	RESISTOR
20	RESISTOR
21	RESISTOR
22	RESISTOR
23	RESISTOR
24	RESISTOR
25	RESISTOR
26	RESISTOR
27	RESISTOR
28	RESISTOR
29	RESISTOR
30	RESISTOR
31	RESISTOR
32	RESISTOR
33	RESISTOR
34	RESISTOR
35	RESISTOR
36	RESISTOR
37	RESISTOR
38	RESISTOR
39	RESISTOR
40	RESISTOR
41	RESISTOR
42	RESISTOR
43	RESISTOR
44	RESISTOR
45	RESISTOR
46	RESISTOR
47	RESISTOR
48	RESISTOR
49	RESISTOR
50	RESISTOR
51	RESISTOR
52	RESISTOR
53	RESISTOR
54	RESISTOR
55	RESISTOR
56	RESISTOR
57	RESISTOR
58	RESISTOR
59	RESISTOR
60	RESISTOR
61	RESISTOR
62	RESISTOR
63	RESISTOR
64	RESISTOR
65	RESISTOR
66	RESISTOR
67	RESISTOR
68	RESISTOR
69	RESISTOR
70	RESISTOR
71	RESISTOR
72	RESISTOR
73	RESISTOR
74	RESISTOR
75	RESISTOR
76	RESISTOR
77	RESISTOR
78	RESISTOR
79	RESISTOR
80	RESISTOR
81	RESISTOR
82	RESISTOR
83	RESISTOR
84	RESISTOR
85	RESISTOR
86	RESISTOR
87	RESISTOR
88	RESISTOR
89	RESISTOR
90	RESISTOR
91	RESISTOR
92	RESISTOR
93	RESISTOR
94	RESISTOR
95	RESISTOR
96	RESISTOR
97	RESISTOR
98	RESISTOR
99	RESISTOR
100	RESISTOR

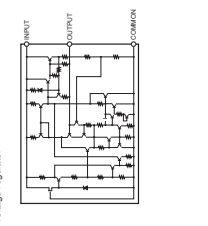
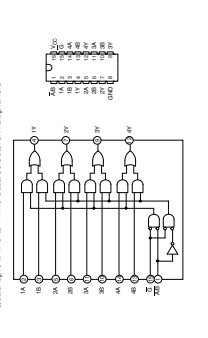
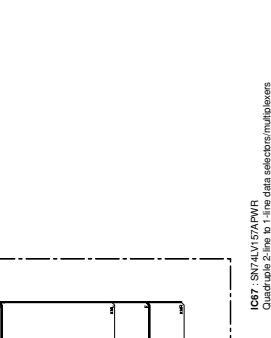
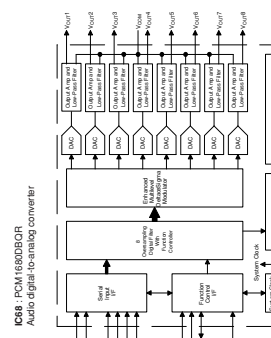
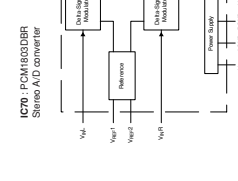
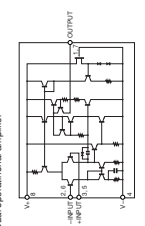

●電圧は、内部抵抗10Ωの電圧降下で測定したものです。
●1印のある部品は、安全性能部品を示しています。部品の交換が厳禁の部品。
●本回路図は標準回路です。改修の必要なく交換することができません。

★ All voltages are measured with a 10MΩV DC electronic volt meter.
★ Components having special characteristics are marked "1", and must be replaced with the same type.
★ Schematic diagram is subjected to change without notice.

OPERATION RX-V559/DSP-AX559

REF. NO.	LOC.	QTY.	DESCRIPTION	MANUFACTURER	REMARKS
41	CB18	1	RESISTOR	DAIICHI	
42	CB18	1	RESISTOR	DAIICHI	
43	F101	1	FUSE	DAIICHI	
44	CB18	1	RESISTOR	DAIICHI	
45	CB18	1	RESISTOR	DAIICHI	
46	CB18	1	RESISTOR	DAIICHI	
47	CB18	1	RESISTOR	DAIICHI	
48	F100	1	FUSE	DAIICHI	
49	T100	1	TRANSFORMER	DAIICHI	
50	CB18	1	RESISTOR	DAIICHI	
51	CB18	1	RESISTOR	DAIICHI	
52	CB18	1	RESISTOR	DAIICHI	
53	CB18	1	RESISTOR	DAIICHI	
54	CB18	1	RESISTOR	DAIICHI	
55	CB18	1	RESISTOR	DAIICHI	
56	CB18	1	RESISTOR	DAIICHI	
57	CB18	1	RESISTOR	DAIICHI	
58	CB18	1	RESISTOR	DAIICHI	
59	CB18	1	RESISTOR	DAIICHI	
60	CB18	1	RESISTOR	DAIICHI	
61	CB18	1	RESISTOR	DAIICHI	
62	CB18	1	RESISTOR	DAIICHI	
63	CB18	1	RESISTOR	DAIICHI	
64	CB18	1	RESISTOR	DAIICHI	
65	CB18	1	RESISTOR	DAIICHI	
66	CB18	1	RESISTOR	DAIICHI	
67	CB18	1	RESISTOR	DAIICHI	
68	CB18	1	RESISTOR	DAIICHI	
69	CB18	1	RESISTOR	DAIICHI	
70	CB18	1	RESISTOR	DAIICHI	
71	CB18	1	RESISTOR	DAIICHI	
72	CB18	1	RESISTOR	DAIICHI	
73	CB18	1	RESISTOR	DAIICHI	
74	CB18	1	RESISTOR	DAIICHI	
75	CB18	1	RESISTOR	DAIICHI	
76	CB18	1	RESISTOR	DAIICHI	
77	CB18	1	RESISTOR	DAIICHI	
78	CB18	1	RESISTOR	DAIICHI	
79	CB18	1	RESISTOR	DAIICHI	
80	CB18	1	RESISTOR	DAIICHI	
81	CB18	1	RESISTOR	DAIICHI	
82	CB18	1	RESISTOR	DAIICHI	
83	CB18	1	RESISTOR	DAIICHI	
84	CB18	1	RESISTOR	DAIICHI	
85	CB18	1	RESISTOR	DAIICHI	
86	CB18	1	RESISTOR	DAIICHI	
87	CB18	1	RESISTOR	DAIICHI	
88	CB18	1	RESISTOR	DAIICHI	
89	CB18	1	RESISTOR	DAIICHI	
90	CB18	1	RESISTOR	DAIICHI	
91	CB18	1	RESISTOR	DAIICHI	
92	CB18	1	RESISTOR	DAIICHI	
93	CB18	1	RESISTOR	DAIICHI	
94	CB18	1	RESISTOR	DAIICHI	
95	CB18	1	RESISTOR	DAIICHI	
96	CB18	1	RESISTOR	DAIICHI	
97	CB18	1	RESISTOR	DAIICHI	
98	CB18	1	RESISTOR	DAIICHI	
99	CB18	1	RESISTOR	DAIICHI	
100	CB18	1	RESISTOR	DAIICHI	

REF. NO.	LOC.	QTY.	DESCRIPTION	MANUFACTURER	REMARKS
101	CB18	1	RESISTOR	DAIICHI	
102	CB18	1	RESISTOR	DAIICHI	
103	CB18	1	RESISTOR	DAIICHI	
104	CB18	1	RESISTOR	DAIICHI	
105	CB18	1	RESISTOR	DAIICHI	
106	CB18	1	RESISTOR	DAIICHI	
107	CB18	1	RESISTOR	DAIICHI	
108	CB18	1	RESISTOR	DAIICHI	
109	CB18	1	RESISTOR	DAIICHI	
110	CB18	1	RESISTOR	DAIICHI	
111	CB18	1	RESISTOR	DAIICHI	
112	CB18	1	RESISTOR	DAIICHI	
113	CB18	1	RESISTOR	DAIICHI	
114	CB18	1	RESISTOR	DAIICHI	
115	CB18	1	RESISTOR	DAIICHI	
116	CB18	1	RESISTOR	DAIICHI	
117	CB18	1	RESISTOR	DAIICHI	
118	CB18	1	RESISTOR	DAIICHI	
119	CB18	1	RESISTOR	DAIICHI	
120	CB18	1	RESISTOR	DAIICHI	
121	CB18	1	RESISTOR	DAIICHI	
122	CB18	1	RESISTOR	DAIICHI	
123	CB18	1	RESISTOR	DAIICHI	
124	CB18	1	RESISTOR	DAIICHI	
125	CB18	1	RESISTOR	DAIICHI	
126	CB18	1	RESISTOR	DAIICHI	
127	CB18	1	RESISTOR	DAIICHI	
128	CB18	1	RESISTOR	DAIICHI	
129	CB18	1	RESISTOR	DAIICHI	
130	CB18	1	RESISTOR	DAIICHI	
131	CB18	1	RESISTOR	DAIICHI	
132	CB18	1	RESISTOR	DAIICHI	
133	CB18	1	RESISTOR	DAIICHI	
134	CB18	1	RESISTOR	DAIICHI	
135	CB18	1	RESISTOR	DAIICHI	
136	CB18	1	RESISTOR	DAIICHI	
137	CB18	1	RESISTOR	DAIICHI	
138	CB18	1	RESISTOR	DAIICHI	
139	CB18	1	RESISTOR	DAIICHI	
140	CB18	1	RESISTOR	DAIICHI	

REF. NO.	LOC.	QTY.	DESCRIPTION	MANUFACTURER	REMARKS
141	CB18	1	RESISTOR	DAIICHI	
142	CB18	1	RESISTOR	DAIICHI	
143	CB18	1	RESISTOR	DAIICHI	
144	CB18	1	RESISTOR	DAIICHI	
145	CB18	1	RESISTOR	DAIICHI	
146	CB18	1	RESISTOR	DAIICHI	
147	CB18	1	RESISTOR	DAIICHI	
148	CB18	1	RESISTOR	DAIICHI	
149	CB18	1	RESISTOR	DAIICHI	
150	CB18	1	RESISTOR	DAIICHI	
151	CB18	1	RESISTOR	DAIICHI	
152	CB18	1	RESISTOR	DAIICHI	
153	CB18	1	RESISTOR	DAIICHI	
154	CB18	1	RESISTOR	DAIICHI	
155	CB18	1	RESISTOR	DAIICHI	
156	CB18	1	RESISTOR	DAIICHI	
157	CB18	1	RESISTOR	DAIICHI	
158	CB18	1	RESISTOR	DAIICHI	
159	CB18	1	RESISTOR	DAIICHI	
160	CB18	1	RESISTOR	DAIICHI	
161	CB18	1	RESISTOR	DAIICHI	
162	CB18	1	RESISTOR	DAIICHI	
163	CB18	1	RESISTOR	DAIICHI	
164	CB18	1	RESISTOR	DAIICHI	
165	CB18	1	RESISTOR	DAIICHI	
166	CB18	1	RESISTOR	DAIICHI	
167	CB18	1	RESISTOR	DAIICHI	
168	CB18	1	RESISTOR	DAIICHI	
169	CB18	1	RESISTOR	DAIICHI	
170	CB18	1	RESISTOR	DAIICHI	
171	CB18	1	RESISTOR	DAIICHI	
172	CB18	1	RESISTOR	DAIICHI	
173	CB18	1	RESISTOR	DAIICHI	
174	CB18	1	RESISTOR	DAIICHI	
175	CB18	1	RESISTOR	DAIICHI	
176	CB18	1	RESISTOR	DAIICHI	
177	CB18	1	RESISTOR	DAIICHI	
178	CB18	1	RESISTOR	DAIICHI	
179	CB18	1	RESISTOR	DAIICHI	
180	CB18	1	RESISTOR	DAIICHI	

REF. NO.	LOC.	QTY.	DESCRIPTION	MANUFACTURER	REMARKS
181	CB18	1	RESISTOR	DAIICHI	
182	CB18	1	RESISTOR	DAIICHI	
183	CB18	1	RESISTOR	DAIICHI	
184	CB18	1	RESISTOR	DAIICHI	
185	CB18	1	RESISTOR	DAIICHI	
186	CB18	1	RESISTOR	DAIICHI	
187	CB18	1	RESISTOR	DAIICHI	
188	CB18	1	RESISTOR	DAIICHI	
189	CB18	1	RESISTOR	DAIICHI	
190	CB18	1	RESISTOR	DAIICHI	
191	CB18	1	RESISTOR	DAIICHI	
192	CB18	1	RESISTOR	DAIICHI	
193	CB18	1	RESISTOR	DAIICHI	
194	CB18	1	RESISTOR	DAIICHI	
195	CB18	1	RESISTOR	DAIICHI	
196	CB18	1	RESISTOR	DAIICHI	
197	CB18	1	RESISTOR	DAIICHI	
198	CB18	1	RESISTOR	DAIICHI	
199	CB18	1	RESISTOR	DAIICHI	
200	CB18	1	RESISTOR	DAIICHI	
201	CB18	1	RESISTOR	DAIICHI	
202	CB18	1	RESISTOR	DAIICHI	
203	CB18	1	RESISTOR	DAIICHI	
204	CB18	1	RESISTOR	DAIICHI	
205	CB18	1	RESISTOR	DAIICHI	
206	CB18	1	RESISTOR	DAIICHI	
207	CB18	1	RESISTOR	DAIICHI	
208	CB18	1	RESISTOR	DAIICHI	
209	CB18	1	RESISTOR	DAIICHI	
210	CB18	1	RESISTOR	DAIICHI	
211	CB18	1	RESISTOR	DAIICHI	
212	CB18	1	RESISTOR	DAIICHI	
213	CB18	1	RESISTOR	DAIICHI	
214	CB18	1	RESISTOR	DAIICHI	
215	CB18	1	RESISTOR	DAIICHI	
216	CB18	1	RESISTOR	DAIICHI	
217	CB18	1	RESISTOR	DAIICHI	
218	CB18	1	RESISTOR	DAIICHI	
219	CB18	1	RESISTOR	DAIICHI	
220	CB18	1	RESISTOR	DAIICHI	

U.C.T. K. A. G. models
to POWER TRANSFORMER

Page 84 [E2]
to FUNCTION (3) W005A W005B

NOTICE (more!)

R.L. models

U.C.T. K. A. G. models

U.S.A.

CANADA

CHINA

INDONESIA

ITALY

JAPAN

KOREA

NETHERLANDS

PHILIPPINES

RUSSIA

SOUTH AFRICA

SOUTH KOREA

TAIWAN

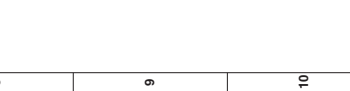
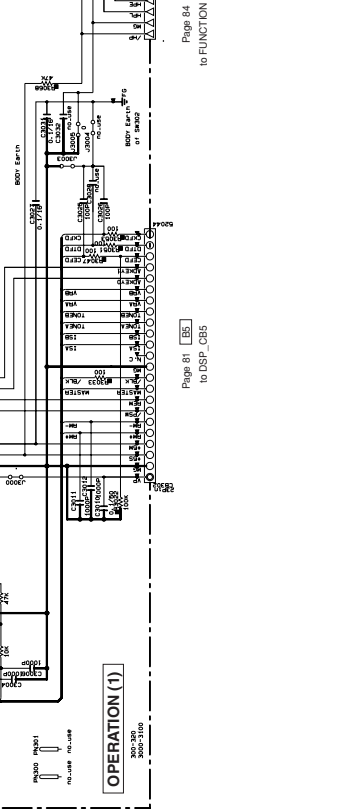
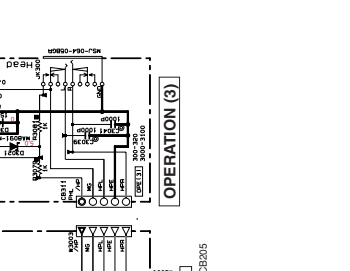
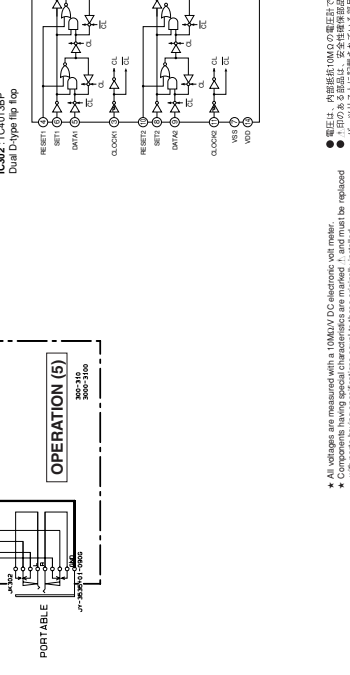
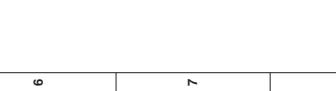
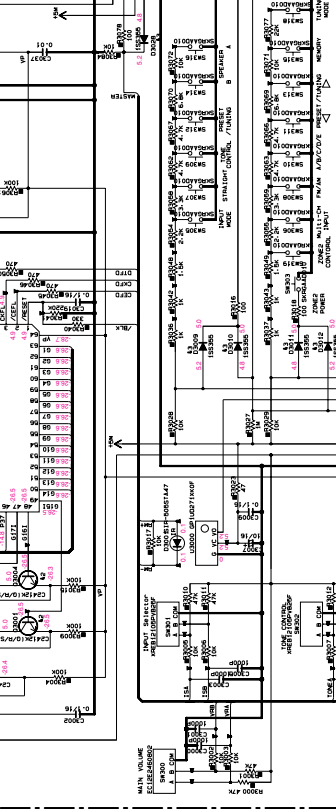
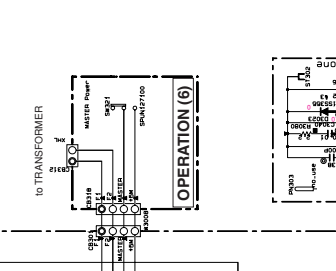
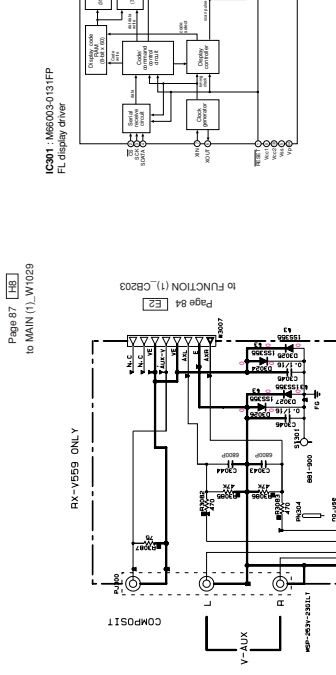
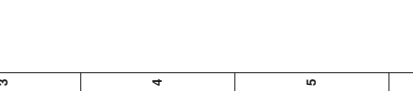
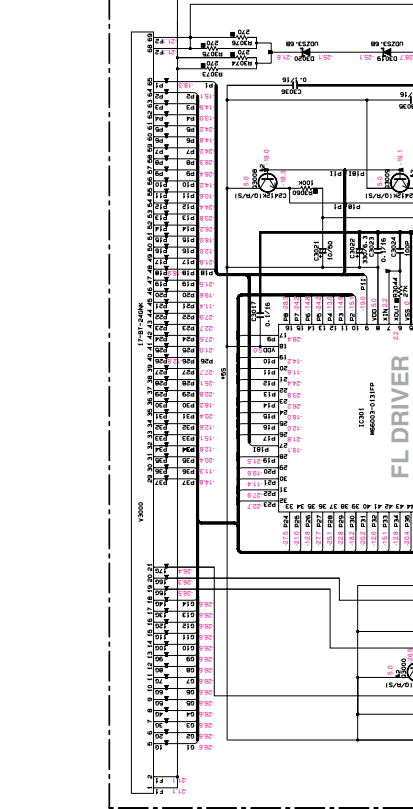
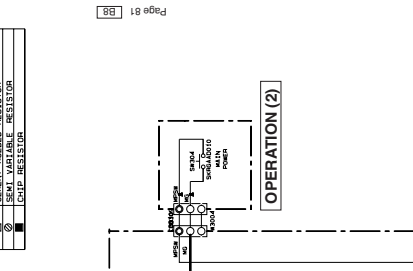
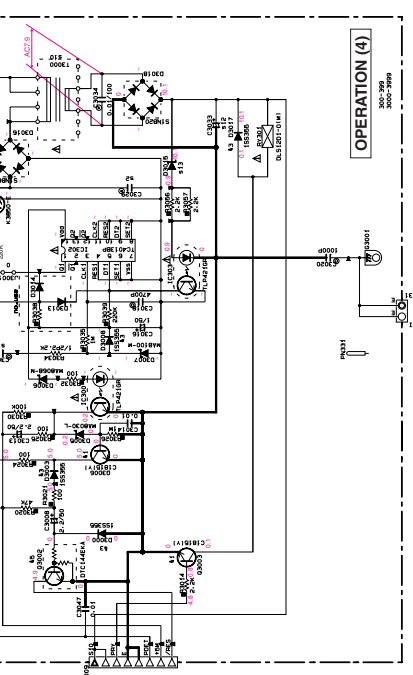

★ All voltages are measured with a 10MΩV DC electronic volt meter.
★ 1印のある部品は、安全特種部品を示しています。部品の交換が厳禁されます。
★ 1印のある部品は、安全特種部品を示しています。部品の交換が厳禁されます。
★ 本回路図は修正版です。改訂の必要がなくなり変更することがあります。

OPERATION HTR-5950

Notes (Cont. from Page 1)

RESISTOR	PARTS NAME	DATE1	DATE2
1	CARBON FILM RESISTOR (D.F.O.)		
2	META OXIDE FILM RESISTOR		
3	META PLATE RESISTOR		
4	FIBRE PAPER CARBON FILM RESISTOR		
5	TEMPERATURE COMPENSATED CARBON FILM RESISTOR		
6	CHIP RESISTOR		

CAPACITOR	PARTS NAME	DATE1	DATE2
1	NON POLARIZED ELECTROLYTIC CAPACITOR		
2	ALUMINUM ELECTROLYTIC CAPACITOR		
3	NO MARK CERAMIC CAPACITOR		
4	CERAMIC CAPACITOR		
5	DIAPHRAGM CERAMIC CAPACITOR		
6	DISC CERAMIC CAPACITOR		
7	MONOLITHIC CERAMIC CAPACITOR		
8	SEMI CONDUCTIVE CERAMIC CAPACITOR		

NOTICE (Impor 1)

(U)..... U.S.A
 (C)..... CANADA
 (T)..... TAIWAN
 (K)..... KOREA
 (B)..... BRITISH I.
 (G)..... EUROPE
 (E)..... SOUTH EUROPE
 (V)..... TAIWAN

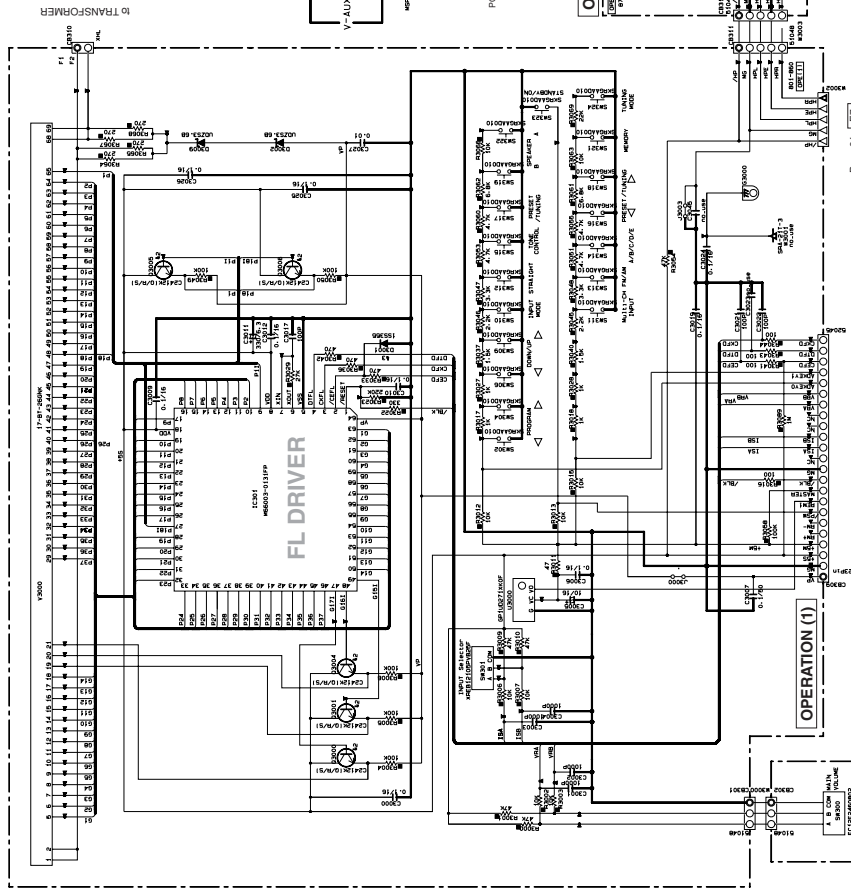

Page 54 [E7] to FUNCTION (1)_CB205

Page 51 [E5] to DSP_CB5

OPERATION (6)

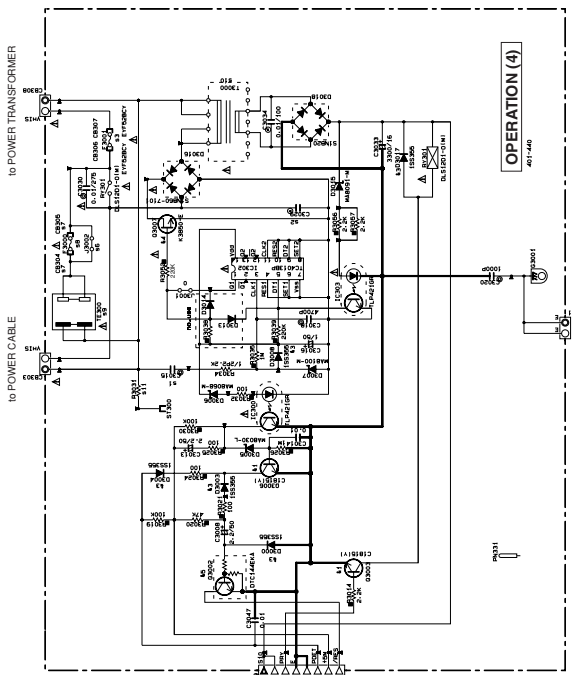

OPERATION (4)

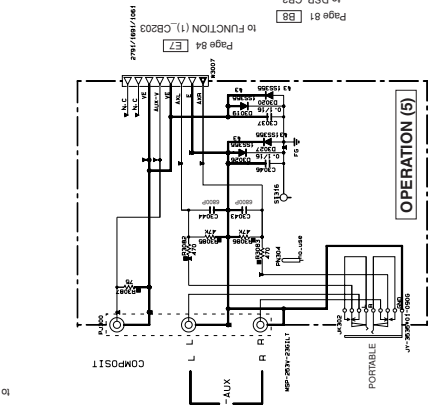

OPERATION (5)

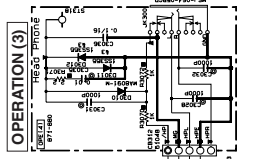

OPERATION (3)

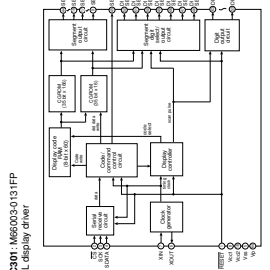

IC301: M6503-0151FP FT display driver

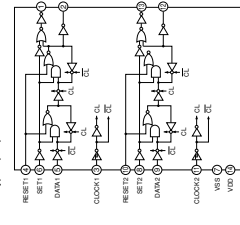

IC302: TC4013BP Dual D-type flip flop

* All voltages are measured with a 100MΩ/100pF impedance with meter.
 * Components having special characteristics are marked 1, and must be replaced with parts having specifications equals to those originally installed.
 * Schematic diagram is subject to change without notice.

■ REPLACEMENT PARTS LIST

• ELECTRICAL COMPONENT PARTS

WARNING

- Components having special characteristics are marked \triangle and must be replaced with parts having specifications equal to those originally installed.
- \triangle 印のある部分は、安全確保部品を示しています。部品の交換が必要な場合、パーツリストに記載されている部品を使用してください。
- 部品価格ランクは、予告なく変更することがあります。

ABBREVIATIONS IN THIS LIST ARE AS FOLLOWS:

C.A.EL.CHP	: CHIP ALUMI.ELECTROLYTIC CAP	L.EMIT	: LIGHT EMITTING MODULE
C.CE	: CERAMIC CAP	LED.DSPLY	: LED DISPLAY
C.CE.ARRAY	: CERAMIC CAP ARRAY	LED.INFRD	: LED, INFRARED
C.CE.CHP	: CHIP CERAMIC CAP	MODUL.RF	: MODULATOR, RF
C.CE.ML	: MULTILAYER CERAMIC CAP	PHOT.CPL	: PHOTO COUPLER
C.CE.M.CHP	: CHIP MULTILAYER CERAMIC CAP	PHOT.INTR	: PHOTO INTERRUPTER
C.CE.SAFTY	: RECOGNIZED CERAMIC CAP	PHOT.RFLCT	: PHOTO REFLECTOR
C.CE.TUBLR	: CERAMIC TUBULAR CAP	PIN.TEST	: PIN, TEST POINT
C.CE.SMI	: SEMI CONDUCTIVE CERAMIC CAP	PLST.RIVET	: PLASTIC RIVET
C.EL	: ELECTROLYTIC CAP	R.ARRAY	: RESISTOR ARRAY
C.MICA	: MICA CAP	R.CAR.	: CARBON RESISTOR
C.ML.FLM	: MULTILAYER FILM CAP	R.CAR.CHP	: CHIP RESISTOR
C.MP	: METALLIZED PAPER CAP	R.CAR.FP	: FLAME PROOF CARBON RESISTOR
C.MYLAR	: MYLAR FILM CAP	R.FUS	: FUSABLE RESISTOR
C.MYLAR.ML	: MULTILAYER MYLAR FILM CAP	R.MTL.CHP	: CHIP METAL FILM RESISTOR
C.PAPER	: PAPER CAPACITOR	R.MTL.FLM	: METAL FILM RESISTOR
C.PLS	: POLYSTYRENE FILM CAP	R.MTL.OXD	: METAL OXIDE FILM RESISTOR
C.POL	: POLYESTER FILM CAP	R.MTL.PLAT	: METAL PLATE RESISTOR
C.POLY	: POLYETHYLENE FILM CAP	RSNR.CE	: CERAMIC RESONATOR
C.PP	: POLYPROPYLENE FILM CAP	RSNR.CRYS	: CRYSTAL RESONATOR
C.TNTL	: TANTALUM CAP	R.TW.CEM	: TWIN CEMENT FIXED RESISTOR
C.TNTL.CHP	: CHIP TANTALUM CAP	R.CEMENT	: CEMENT RESISTOR
C.TRIM	: TRIMMER CAP	SCR.BND.HD	: BIND HEAD B-TIGHT SCREW
CN	: CONNECTOR	SCR.BW.HD	: BW HEAD TAPPING SCREW
CN.BS.PIN	: CONNECTOR, BASE PIN	SCR.CUP	: CUP TIGHT SCREW
CN.CANNON	: CONNECTOR, CANNON	SCR.TERM	: SCREW TERMINAL
CN.DIN	: CONNECTOR, DIN	SCR.TR	: SCREW, TRANSISTOR
CN.FLAT	: CONNECTOR, FLAT CABLE	SUPRT.PCB	: SUPPORT, P.C.B.
CN.POST	: CONNECTOR, BASE POST	SURG.PRTCT	: SURGE PROTECTOR
COIL.MX.AM	: COIL, AM MIX	SW.TACT	: TACT SWITCH
COIL.AT.FM	: COIL, FM ANTENNA	SW.LEAF	: LEAF SWITCH
COIL.DT.FM	: COIL, FM DETECT	SW.LEVER	: LEVER SWITCH
COIL.MX.FM	: COIL, FM MIX	SW.MICRO	: MICRO SWITCH
COIL.OUTPT	: OUTPUT COIL	SW.PUSH	: PUSH SWITCH
DIOD.ARRAY	: DIODE ARRAY	SW.RT.ENC	: ROTARY ENCODER
DIODE.BRG	: DIODE BRIDGE	SW.RT.MTR	: ROTARY SWITCH WITH MOTOR
DIODE.CHP	: CHIP DIODE	SW.RT	: ROTARY SWITCH
DIODE.VAR	: VARACTOR DIODE	SW.SLIDE	: SLIDE SWITCH
DIOD.Z.CHP	: CHIP ZENER DIODE	TERM.SP	: SPEAKER TERMINAL
DIODE.ZENR	: ZENER DIODE	TERM.WRAP	: WRAPPING TERMINAL
DSCR.CE	: CERAMIC DISCRIMINATOR	THRMST.CHP	: CHIP THERMISTOR
FER.BEAD	: FERRITE BEADS	TR.CHP	: CHIP TRANSISTOR
FER.CORE	: FERRITE CORE	TR.DGT	: DIGITAL TRANSISTOR
FET.CHP	: CHIP FET	TR.DGT.CHP	: CHIP DIGITAL TRANSISTOR
FL.DSPLY	: FLUORESCENT DISPLAY	TRANS	: TRANSFORMER
FLTR.CE	: CERAMIC FILTER	TRANS.PULS	: PULSE TRANSFORMER
FLTR.COMB	: COMB FILTER MODULE	TRANS.PWR	: POWER TRANSFORMER ASS'Y
FLTR.LC.RF	: LC FILTER, EMI	TUNER.AM	: TUNER PACK, AM
GND.MTL	: GROUND PLATE	TUNER.FM	: TUNER PACK, FM
GND.TERM	: GROUND TERMINAL	TUNER.PK	: FRONT-END TUNER PACK
HOLDER.FUS	: FUSE HOLDER	VR	: ROTARY POTENTIOMETER
IC.PRTCT	: IC PROTECTOR	VR.MTR	: POTENTIOMETER WITH MOTOR
JUMPER.CN	: JUMPER CONNECTOR	VR.SW	: POTENTIOMETER WITH ROTARY SW
JUMPER.TST	: JUMPER, TEST POINT	VR.SLIDE	: SLIDE POTENTIOMETER
L.DTCT	: LIGHT DETECTING MODULE	VR.TRIM	: TRIMMER POTENTIOMETER

RX-V559/DSP-AX559

HTR-5950

P.C.B. DSP

Ref. No.	Part No.	Description	Remarks	Markets	部 品 名	Rank	
	WG681000	P. C. B.	DSP	559	J	P C B D S P	
	WG681100	P. C. B.	DSP	559	UC	P C B D S P	
	WG681200	P. C. B.	DSP	559	R	P C B D S P	
	WG681300	P. C. B.	DSP	559	T	P C B D S P	
	WG681400	P. C. B.	DSP	559	K	P C B D S P	
	WG681500	P. C. B.	DSP	559	A	P C B D S P	
	WG681700	P. C. B.	DSP	559	GE	P C B D S P	
	WG681800	P. C. B.	DSP	559	L	P C B D S P	
	WG682000	P. C. B.	DSP	5950	UC	P C B D S P	
	WG956300	P. C. B.	DSP	5950	T	P C B D S P	
	WG682100	P. C. B.	DSP	5950	A	P C B D S P	
CB1	VQ047900	CN	29P			F F C コネクタ	03
CB2	VP082900	CN. BS. PIN	25P			F F C コネクタ	02
CB3	VB390400	CN. BS. PIN	8P			ベースピン	01
CB4	VB390200	CN. BS. PIN	6P			コネクタベースポスト	01
CB5	VM689000	CN. BS. PIN	23P			F F C コネクタ	02
CB7	VQ044400	CN. BS. PIN	9P			F F C コネクタ	01
CB9	VB390300	CN. BS. PIN	7P			ベースピン	01
CB52	WE161800	CN. BS. PIN	4P		UC	シリアルバスコネクタ	
CB56	VQ047500	CN. BS. PIN	20P			F F C コネクタ	01
CB57	VB390600	CN. BS. PIN	10P			コネクタベースポスト	01
C1	US064100	C. CE. CHP	0.01uF	50V B		チップセラコン	01
C2	US062100	C. CE. CHP	100pF	50V B		チップセラコン	01
C3	UR868100	C. EL	100uF	50V		ケミコン	01
C4	US063100	C. CE. CHP	1000pF	50V B		チップセラコン	01
C5-7	US062100	C. CE. CHP	100pF	50V B		チップセラコン	01
C8	US135100	C. CE. CHP	0.1uF	16V		チップセラコン	01
C9	UR867100	C. EL	10uF	50V		ケミコン	01
C10	UR837100	C. EL	10uF	16V		ケミコン	01
C11	UR818220	C. EL	220uF	6.3V		ケミコン	01
C12	WB165500	C. EL	0.33F	5.5V		ゴールドキャパシタ	
C13	UR818220	C. EL	220uF	6.3V		ケミコン	01
C14	UR837330	C. EL	33uF	16V		ケミコン	01
C15	UR838100	C. EL	100uF	16V		ケミコン	01
C16-21	US135100	C. CE. CHP	0.1uF	16V		チップセラコン	01
C22-31	US063100	C. CE. CHP	1000pF	50V B		チップセラコン	01
C32-36	UR866220	C. EL	2.2uF	50V		ケミコン	01
C37-39	US135100	C. CE. CHP	0.1uF	16V		チップセラコン	01
C40-48	US064100	C. CE. CHP	0.01uF	50V B		チップセラコン	01
C50-63	US135100	C. CE. CHP	0.1uF	16V		チップセラコン	01
C201	US061220	C. CE. CHP	22pF	50V B		チップセラコン	01
C202-205	US135100	C. CE. CHP	0.1uF	16V		チップセラコン	01
C208	US135100	C. CE. CHP	0.1uF	16V		チップセラコン	01
C209	UR847220	C. EL	22uF	25V		ケミコン	01
C210	UR238100	C. EL	100uF	16V		ケミコン	
C211	WG251600	C. CE. CHP	4.7uF	6.3V		チップセラ	
C212	UR237470	C. EL	47uF	16V		ケミコン	
C215	US060500	C. CE. CHP	5pF	50V B	UC	チップセラコン	01
C216-217	US035100	C. CE. CHP	0.1uF	16V B	UC	チップセラコン	01
C218	US060500	C. CE. CHP	5pF	50V B	UC	チップセラコン	01
C219	US135100	C. CE. CHP	0.1uF	16V	UC	チップセラコン	01
C220	US035100	C. CE. CHP	0.1uF	16V B	UC	チップセラコン	01
C221	WG251600	C. CE. CHP	4.7uF	6.3V		チップセラ	
C222	US135100	C. CE. CHP	0.1uF	16V		チップセラコン	01
C223	UR019220	C. EL	2200uF	6.3V		ケミコン	
C224	UR238100	C. EL	100uF	16V		ケミコン	
C225	WG251600	C. CE. CHP	4.7uF	6.3V		チップセラ	
C226-227	US135100	C. CE. CHP	0.1uF	16V	UC	チップセラコン	01
C228	US135330	C. CE. CHP	0.33uF	16V		チップセラコン	01
C229	UR038100	C. EL	100uF	16V		ケミコン	

* New Parts * 新規部品

RX-V559/HTR-5950/
DSP-AX559

RX-V559/DSP-AX559

HTR-5950

P.C.B. DSP

Ref. No.	Part No.	Description	Remarks	Markets	部 品 名	Rank	
C230-231	US135100	C. CE. CHP	0.1uF 16V		UC	チップセラコン	01
C232-233	US135100	C. CE. CHP	0.1uF 16V			チップセラコン	01
C234	VE326000	C. MYLAR	0.1uF 50V			マイラーコン	01
C235	UA654220	C. MYLAR	0.022uF 50V J			マイラーコン	01
C236-238	US135100	C. CE. CHP	0.1uF 16V			チップセラコン	01
C239	US062100	C. CE. CHP	100pF 50V B			チップセラコン	01
C241	US135100	C. CE. CHP	0.1uF 16V		UC	チップセラコン	01
C242	UR238100	C. EL	100uF 16V			ケミコン	01
C243	US062100	C. CE. CHP	100pF 50V B			チップセラコン	01
C244	UR238100	C. EL	100uF 16V			ケミコン	01
C245-246	US135100	C. CE. CHP	0.1uF 16V			チップセラコン	01
C247	US062100	C. CE. CHP	100pF 50V B			チップセラコン	01
C248	UR238100	C. EL	100uF 16V			ケミコン	01
C249-250	US061180	C. CE. CHP	18pF 50V B			チップセラコン	01
C251	UR238100	C. EL	100uF 16V			ケミコン	01
C252	UR867100	C. EL	10uF 50V			ケミコン	01
C253	US126100	C. CE. CHP	1uF 10V			チップセラコン	01
C254	US035100	C. CE. CHP	0.1uF 16V B			チップセラコン	01
C255-283	US135100	C. CE. CHP	0.1uF 16V			チップセラコン	01
C284	UR837470	C. EL	47uF 16V			ケミコン	01
C285-286	US135100	C. CE. CHP	0.1uF 16V			チップセラコン	01
C287-289	US063100	C. CE. CHP	1000pF 50V B			チップセラコン	01
C290	US035100	C. CE. CHP	0.1uF 16V B			チップセラコン	01
C291	US135100	C. CE. CHP	0.1uF 16V			チップセラコン	01
C292-294	US063100	C. CE. CHP	1000pF 50V B			チップセラコン	01
C295-299	US135100	C. CE. CHP	0.1uF 16V			チップセラコン	01
C300	US135100	C. CE. CHP	0.1uF 16V			チップセラコン	01
C301-313	US061470	C. CE. CHP	47pF 50V B			チップセラコン	01
C314	US064100	C. CE. CHP	0.01uF 50V B			チップセラコン	01
C315	UR837100	C. EL	10uF 16V			ケミコン	01
C316-317	US064100	C. CE. CHP	0.01uF 50V B			チップセラコン	01
C318	US135100	C. CE. CHP	0.1uF 16V			チップセラコン	01
C319	UR238100	C. EL	100uF 16V			ケミコン	01
C320	US126100	C. CE. CHP	1uF 10V			チップセラコン	01
C321	US135330	C. CE. CHP	0.33uF 16V			チップセラコン	01
C322	US062100	C. CE. CHP	100pF 50V B			チップセラコン	01
C323	US035100	C. CE. CHP	0.1uF 16V B			チップセラコン	01
C324	UR837100	C. EL	10uF 16V			ケミコン	01
C325-326	US126100	C. CE. CHP	1uF 10V			チップセラコン	01
C327	UR837100	C. EL	10uF 16V	559	UC	ケミコン	01
C328	US135100	C. CE. CHP	0.1uF 16V	559	UC	チップセラコン	01
C329	US135100	C. CE. CHP	0.1uF 16V			チップセラコン	01
C330	UR238100	C. EL	100uF 16V			ケミコン	01
C331	UR838100	C. EL	100uF 16V	559	UC	ケミコン	01
C332	UR837100	C. EL	10uF 16V			ケミコン	01
C333	US135100	C. CE. CHP	0.1uF 16V			チップセラコン	01
C334	UR837100	C. EL	10uF 16V			ケミコン	01
C335	US135100	C. CE. CHP	0.1uF 16V			チップセラコン	01
C336	UR238100	C. EL	100uF 16V			ケミコン	01
C337-340	US135100	C. CE. CHP	0.1uF 16V			チップセラコン	01
C341-347	UR837100	C. EL	10uF 16V			ケミコン	01
C348-349	UR837470	C. EL	47uF 16V	559	UC	ケミコン	01
C350-351	UA654100	C. MYLAR	0.01uF 50V J			マイラーコン	01
C352-354	US062680	C. CE. CHP	680pF 50V B			チップセラコン	01
C355	UA654470	C. MYLAR	0.047uF 50V J			マイラーコン	01
C356-358	US062680	C. CE. CHP	680pF 50V B			チップセラコン	01
C359-360	US163100	C. CE. CHP	1000pF 50V	559	UC	チップセラコン	01
C361-362	UR837100	C. EL	10uF 16V			ケミコン	01
C363-364	US163100	C. CE. CHP	1000pF 50V	559	UC	チップセラコン	01
C365-367	US062100	C. CE. CHP	100pF 50V B			チップセラコン	01

* New Parts * 新規部品

RX-V559/DSP-AX559

HTR-5950

P.C.B. DSP

Ref. No.	Part No.	Description	Remarks	Markets	部 品 名	Rank
C368	UA653390	C. MYLAR	3900pF 50V J		マイラーコン	01
C369-371	US062100	C. CE. CHP	100pF 50V B		チップセラコン	01
C373-390	US135100	C. CE. CHP	0.1uF 16V		チップセラコン	01
C391-392	US135100	C. CE. CHP	0.1uF 16V	559	チップセラコン	01
C393-398	UR237470	C. EL	47uF 16V		ケミコン	01
C399	US135100	C. CE. CHP	0.1uF 16V		チップセラコン	01
C400-402	US135100	C. CE. CHP	0.1uF 16V		チップセラコン	01
C403-408	US062220	C. CE. CHP	220pF 50V B		チップセラコン	01
C409-410	US135100	C. CE. CHP	0.1uF 16V		チップセラコン	01
C411-412	US064100	C. CE. CHP	0.01uF 50V B		チップセラコン	01
C413	US062680	C. CE. CHP	680pF 50V B		チップセラコン	01
C416	US135100	C. CE. CHP	0.1uF 16V		チップセラコン	01
D1-2	VT332900	DIODE	1SS355		ダイオード	01
D3	VV833200	DIODE	1SS380		ダイオード	01
D4-5	VU992600	DIODE. ZENR	MA8051-M 5.1V		ツェナーダイオード	01
D6	VT332900	DIODE	1SS355		ダイオード	01
D7-9	VU992600	DIODE. ZENR	MA8051-M 5.1V		ツェナーダイオード	01
D10	VT332900	DIODE	1SS355		ダイオード	01
D201-203	WE674800	DIODE	AVRL161A1R1NTB		チップバリスタ	01
D204	VT332900	DIODE	1SS355		ダイオード	01
D206	VT332900	DIODE	1SS355		ダイオード	01
D208-210	VT332900	DIODE	1SS355		ダイオード	01
D212-215	WB081800	DIODE	SB01-05Q		ショットキーダイオード	01
D216-217	VT332900	DIODE	1SS355		ダイオード	01
IC1	X5886A00	IC	RH5RE58AA-T1-FA		電源IC	04
* IC2	X7361A00	IC. CPU	M30625MHP-A98GP	MASK ROM	IC CPU	
IC4-5	X2080A00	IC	SN74AHCT1G32DCKR		ロジックIC	01
IC6	X3833A00	IC	SN74AHC1G08DCKR		ロジックIC	01
IC51	XS534A00	IC	NJM78M05DL1A (TE1)		電源IC	02
IC52	X3936A00	IC	SN74LVU04APWR		ロジックIC	
* IC53	X7195A00	IC	R1172S121D-E2-F		電源IC	
* IC54	X6869A00	IC	NJM2885DL1-33		電源IC	03
IC55	X6227B00	IC	F2602E-01		UC CPU/周辺IC	
IC56	X6989A00	IC	LC89057W-VF4A-E		IC	07
IC58	X6123A00	IC	SN74LV157APWR		UC ロジックIC	02
IC59	X3833A00	IC	SN74AHC1G08DCKR		ロジックIC	01
IC61	X2080A00	IC	SN74AHCT1G32DCKR		UC ロジックIC	01
IC62	X2080A00	IC	SN74AHCT1G32DCKR		ロジックIC	01
IC63	X3824A00	IC	SN74AHC08PWR		ロジックIC	01
IC64	X2590B00	IC	W9816G6CH-7 SDRAM		メモリIC 16M	06
IC65	X3693A00	IC	SN74LV245APWR TRAN		ロジックIC	
* IC66	X7577A00	IC	S29AL004D70TF1020		メモリIC 4M	
IC67	X6123A00	IC	SN74LV157APWR		ロジックIC	02
* IC68	X7355A00	IC	PCM1680DBQR		IC	
* IC69	X7375A00	IC	PCM1781DBQR	559	UC IC	
* IC70	X7357A00	IC	PCM1803DBR		IC	
* IC71-74	X7378A00	IC	NJM4565M (TE1)		アンプIC	
* IC75	X7378A00	IC	NJM4565M (TE1)	559	UC アンプIC	
* IC76	X7378A00	IC	NJM4565M (TE1)		アンプIC	
J201-202		R. CHP	0Ω 1/16W J		UC チップ抵抗	
J203-206		R. CHP	0Ω 1/16W J		JRTKAGEL チップ抵抗	
PJ51	V4483900	JACK. PIN	1P YKC21-3895N		ピンジャック	02
PN1-3	V9637500	PIN	L=70 #18		スタイルピン	
Q1	VP872600	TR	2SA1708 S, T		トランジスタ	01
Q2	VV655700	TR. DGT	DTC144EKA		デジタルトランジスタ	01
Q3-7	VV565500	TR	2SA1037K Q, R, S		トランジスタ	01
Q8	WF767900	FET	5HP01C-TB-E		FET	01
Q9	WF767900	FET	5HP01C-TB-E		FET	01
R21		R. CHP	10Ω 1/16W J		J チップ抵抗	
R21		R. CHP	1.2KΩ 1/16W J		UC チップ抵抗	

* New Parts * 新規部品

RX-V559/HTR-5950/
DSP-AX559

RX-V559/DSP-AX559

HTR-5950

P.C.B. DSP & P.C.B. FUNCTION

Ref. No.	Part No.	Description	Remarks	Markets	部 品 名	Rank	
R21		R. CHP	4.7K Ω 1/16W J		R	チップ抵抗	
R21		R. CHP	6.8K Ω 1/16W J		T	チップ抵抗	
R21		R. CHP	10K Ω 1/16W J		K	チップ抵抗	
R21		R. CHP	15K Ω 1/16W J		A	チップ抵抗	
R21		R. CHP	47K Ω 1/16W J		GE	チップ抵抗	
R21		R. CHP	100K Ω 1/16W J		L	チップ抵抗	
R23		R. CHP	15K Ω 1/16W J		JRTKAGEL	チップ抵抗	
R47		R. CHP	100 Ω 1/16W J		UC	チップ抵抗	
R52-54		R. CHP	100 Ω 1/16W J		UC	チップ抵抗	
R209	HV753100	R. CAR. FP	1 Ω 1/4W			不燃化カーボン抵抗	01
R211		R. CHP	470 Ω 1/16W J		UC	チップ抵抗	
R212		R. CHP	1M Ω 1/16W J		UC	チップ抵抗	
R215-216		R. CHP	100 Ω 1/16W J		UC	チップ抵抗	
R217-218		R. CHP	1K Ω 1/16W J		UC	チップ抵抗	
R219	V8070000	R. MTL. FLM	1 Ω 1W			金属被膜抵抗	01
R221-224		R. CHP	270 Ω 1/16W J		UC	チップ抵抗	
R225		R. CHP	470K Ω 1/16W J		UC	チップ抵抗	
R226	V8070000	R. MTL. FLM	1 Ω 1W			金属被膜抵抗	01
R228		R. CHP	100K Ω 1/16W J		UC	チップ抵抗	
R229		R. CHP	470K Ω 1/16W J		UC	チップ抵抗	
R232-234		R. CHP	100K Ω 1/16W J		UC	チップ抵抗	
R240		R. CHP	47 Ω 1/16W J		UC	チップ抵抗	
R241		R. CHP	22 Ω 1/16W J		UC	チップ抵抗	
R251-252		R. CHP	47 Ω 1/16W J		UC	チップ抵抗	
R319	HV753100	R. CAR. FP	1 Ω 1/4W			不燃化カーボン抵抗	01
R320	V8070400	R. MTL. FLM	15 Ω 1W			金属被膜抵抗	
R322	HV753100	R. CAR. FP	1 Ω 1/4W	559	UC	不燃化カーボン抵抗	01
R323-324	VU224000	R. MTL. FLM	0.22 Ω 1W			金属被膜抵抗	01
R325-326	V8070100	R. MTL. FLM	2.2 Ω 1W			金属被膜抵抗	01
R334-335		R. CHP	10K Ω 1/16W J	559	UC	チップ抵抗	
R338-339		R. CHP	3.9K Ω 1/16W J	559	UC	チップ抵抗	
R354-355		R. CHP	2.7K Ω 1/16W J	559	UC	チップ抵抗	
R356-357		R. MTL. CHP	3.3K Ω 1/16W D	559	UC	チップ金属被膜抵抗	
R365-366		R. MTL. CHP	1.5K Ω 1/16W D	559	UC	チップ金属被膜抵抗	
R389-390		R. CHP	100 Ω 1/16W J	559	UC	チップ抵抗	
U201	WG559700	CN. PHOTO	1P GP1FAV50TK0F			光ファイバデータリンク	
U202-204	WG559800	CN. PHOTO	1P GP1FAV50RK0F			光ファイバ受信器	
XL1	WA674700	RSNR. CE	16MHz CSTLS16M0X51			セラミック振動子	
XL51	WE436500	RSNR. CRY5	45.1584MHz		UC	水晶振動子	
XL52	V3625700	RSNR. CRY5	24.576MHz			水晶振動子	03
	WG686000	P. C. B.	FUNCTION	559	J	P C B ファンクション	
	WG686100	P. C. B.	FUNCTION	559	UCTKA	P C B ファンクション	
	WG686200	P. C. B.	FUNCTION	559	R	P C B ファンクション	
	WG686400	P. C. B.	FUNCTION	559	GE	P C B ファンクション	
	WG686500	P. C. B.	FUNCTION	559	L	P C B ファンクション	
	WG689100	P. C. B.	FUNCTION	5950	UCTA	P C B ファンクション	
CB200	VQ047900	CN	29P			F F Cコネクタ	03
CB201	VB389800	CN. BS. PIN	2P			ベースピン	01
CB202	VQ047500	CN. BS. PIN	20P			F F Cコネクタ	01
CB203	VB390400	CN. BS. PIN	8P			ベースピン	01
CB204	VM859600	CN. BS. PIN	15P			F F Cコネクタ	01
CB205	VB390100	CN. BS. PIN	5P			ベースピン	01
CB206	VB390400	CN. BS. PIN	8P			ベースピン	01
CB207	VB390200	CN. BS. PIN	6P			コネクタベースポスト	01
CB286-289	WE262500	CN	14P SE		J	D端子コネクタ	05
CB290	VN520900	CN. BS. PIN	52045 26P TE			F F Cコネクタ	02
CB291	VQ045400	CN. BS. PIN	25P			F F Cコネクタ	03

* New Parts * 新規部品

P.C.B. FUNCTION

Ref. No.	Part No.	Description	Remarks	Markets	部 品 名	Rank	
* CB313	V9377800	CN. BS. PIN	3P		RL	ベース付ポスト	
* CB314	V9377900	CN. BS. PIN	4P		RL	ベース付ポスト	
CB315	WC050700	CLIP. FUSE	EYF-52BCY		R	ヒューズクリップ	01
CB317	WC050700	CLIP. FUSE	EYF-52BCY		R	ヒューズクリップ	01
C2000	US064100	C. CE. CHP	0.01uF 50V B			チップセラコン	01
C2002-2003	US064100	C. CE. CHP	0.01uF 50V B			チップセラコン	01
C2004	UR837100	C. EL	10uF 16V			ケミコン	01
C2005-2006	FG651470	C. CE	47pF 50V	559		セラコン	01
C2007	UA654100	C. MYLAR	0.01uF 50V J			マイラーコン	01
C2008-2013	US062220	C. CE. CHP	220pF 50V B			チップセラコン	01
C2014-2015	FG651470	C. CE	47pF 50V			セラコン	01
C2016-2019	US062220	C. CE. CHP	220pF 50V B			チップセラコン	01
C2020-2021	FG651470	C. CE	47pF 50V			セラコン	01
C2022-2027	US062220	C. CE. CHP	220pF 50V B			チップセラコン	01
C2028-2030	UR837100	C. EL	10uF 16V			ケミコン	01
C2031	UR837100	C. EL	10uF 16V			ケミコン	01
C2033-2034	UR837100	C. EL	10uF 16V	559		ケミコン	01
C2035	UR837100	C. EL	10uF 16V			ケミコン	01
C2036	UR237100	C. EL	10uF 50V			ケミコン	
C2037-2038	US135100	C. CE. CHP	0.1uF 16V	559		チップセラコン	01
C2039-2040	US135100	C. CE. CHP	0.1uF 16V			チップセラコン	01
C2043	UR237100	C. EL	10uF 50V			ケミコン	
C2044	UR237100	C. EL	10uF 16V			ケミコン	01
C2046-2047	UR237100	C. EL	10uF 16V			ケミコン	01
C2049	UR837100	C. EL	10uF 16V			ケミコン	01
C2050-2051	UR237100	C. EL	10uF 16V			ケミコン	01
C2052	UR837100	C. EL	10uF 16V			ケミコン	01
C2055	UR837100	C. EL	10uF 16V			ケミコン	01
C2057	UR837100	C. EL	10uF 16V			ケミコン	01
C2058-2059	VE326300	C. MYLAR	0.18uF 50V			マイラーコン	01
C2060	UA653470	C. MYLAR	4700pF 50V J			マイラーコン	01
C2061-2064	UR837100	C. EL	10uF 16V			ケミコン	01
C2066-2067	UR837100	C. EL	10uF 16V			ケミコン	01
C2068-2069	VE326200	C. MYLAR	0.15uF 50V			マイラーコン	
C2070	UA653470	C. MYLAR	4700pF 50V J			マイラーコン	01
C2071-2072	US135100	C. CE. CHP	0.1uF 16V			チップセラコン	01
C2073	US062150	C. CE. CHP	150pF 50V B			チップセラコン	01
C2074-2075	UR867470	C. EL	47uF 50V			ケミコン	01
C2076-2077	US062100	C. CE. CHP	100pF 50V B			チップセラコン	01
C2078	UR837100	C. EL	10uF 16V			ケミコン	01
C2079	US135100	C. CE. CHP	0.1uF 16V		GE	チップセラコン	01
C2080-2082	UR837100	C. EL	10uF 16V			ケミコン	01
C2083	US062330	C. CE. CHP	330pF 50V B		GE	チップセラコン	01
C2084	UR837470	C. EL	47uF 16V			ケミコン	01
C2085-2086	UR867470	C. EL	47uF 50V			ケミコン	01
C2087-2092	UR837100	C. EL	10uF 16V			ケミコン	01
C2093	US062330	C. CE. CHP	330pF 50V B		GE	チップセラコン	01
C2094	UR837100	C. EL	10uF 16V			ケミコン	01
C2095	UR837100	C. EL	10uF 16V			ケミコン	01
C2096	UR837470	C. EL	47uF 16V			ケミコン	01
C2097	UR837470	C. EL	47uF 16V		GE	ケミコン	01
C2100	UR837470	C. EL	47uF 16V		GE	ケミコン	01
C2101-2102	US135100	C. CE. CHP	0.1uF 16V			チップセラコン	01
C2106	US062560	C. CE. CHP	560pF 50V B		GE	チップセラコン	01
C2107-2108	UR837100	C. EL	10uF 16V			ケミコン	01
C2111-2112	US062100	C. CE. CHP	100pF 50V B			チップセラコン	01
C2114-2115	US061470	C. CE. CHP	47pF 50V B			チップセラコン	01
C2116-2117	UR837100	C. EL	10uF 16V			ケミコン	01
C2118	US061270	C. CE. CHP	27pF 50V B		GE	チップセラコン	01
C2120	US135100	C. CE. CHP	0.1uF 16V		GE	チップセラコン	01

* New Parts * 新規部品

RX-V559/HTR-5950/
DSP-AX559

RX-V559/DSP-AX559

HTR-5950

P.C.B. FUNCTION

Ref. No.	Part No.	Description	Remarks	Markets	部 品 名	Rank	
C2122	US061270	C. CE. CHP	27pF 50V B		GE	チップセラコン	01
C2123-2124	US061220	C. CE. CHP	22pF 50V B			チップセラコン	01
C2127	UR837470	C. EL	47uF 16V		GE	ケミコン	01
C2128-2129	US062100	C. CE. CHP	100pF 50V B			チップセラコン	01
C2130-2131	UR839100	C. EL	1000uF 16V			ケミコン	01
C2132-2133	US062100	C. CE. CHP	100pF 50V B			チップセラコン	01
C2135	US063100	C. CE. CHP	1000pF 50V B			チップセラコン	01
C2136	US062100	C. CE. CHP	100pF 50V B			チップセラコン	01
C2137	US064100	C. CE. CHP	0.01uF 50V B			チップセラコン	01
C2138	US062100	C. CE. CHP	100pF 50V B			チップセラコン	01
C2140	US064100	C. CE. CHP	0.01uF 50V B			チップセラコン	01
C2141-2142	UR837100	C. EL	10uF 16V		UCTKA	ケミコン	01
C2851-2852	UR837100	C. EL	10uF 16V			ケミコン	01
C2853-2855	UR837470	C. EL	47uF 16V			ケミコン	01
C2856	UR837100	C. EL	10uF 16V			ケミコン	01
C2857	UR837470	C. EL	47uF 16V			ケミコン	01
C2858	UR837100	C. EL	10uF 16V			ケミコン	01
C2901-2903	US060800	C. CE. CHP	8pF 50V B			チップセラコン	01
C2904-2912	US060800	C. CE. CHP	8pF 50V B		J	チップセラコン	01
C2913-2915	US064100	C. CE. CHP	0.01uF 50V B		J	チップセラコン	01
C2916-2918	US060800	C. CE. CHP	8pF 50V B		J	チップセラコン	01
C2919-2921	US135100	C. CE. CHP	0.1uF 16V			チップセラコン	01
C2922	US135100	C. CE. CHP	0.1uF 16V		J	チップセラコン	01
C2923-2925	US135100	C. CE. CHP	0.1uF 16V			チップセラコン	01
C2926	US135100	C. CE. CHP	0.1uF 16V		J	チップセラコン	01
C2927	US064100	C. CE. CHP	0.01uF 50V B			チップセラコン	01
C2928-2929	US135100	C. CE. CHP	0.1uF 16V			チップセラコン	01
C2930	US061220	C. CE. CHP	22pF 50V B			チップセラコン	01
C2931	US062560	C. CE. CHP	560pF 50V B			チップセラコン	01
C2932-2935	US135100	C. CE. CHP	0.1uF 16V			チップセラコン	01
C2936-2938	US061220	C. CE. CHP	22pF 50V B			チップセラコン	01
D2000-2001	VU994300	D1ODE. ZENR	MA8075-H 7.7V			ツェナーダイオード	
D2002	VU993000	D1ODE. ZENR	MA8056-M 5.6V			ツェナーダイオード	01
D2003-2004	VV307700	D1ODE	1N4002S			ダイオード	01
D2005-2006	VT332900	D1ODE	1SS355			ダイオード	01
D2851-2859	VT332900	D1ODE	1SS355		J	ダイオード	01
D2860-2867	VT332900	D1ODE	1SS355			ダイオード	01
F3002	KB000790	FUSE	T4A 250V		R	ヒューズ	01
IC200	X5092A00	IC	BD3816K1	559		IC	
IC201	X3547A00	IC	BD3841FS			IC	06
IC202	X3547A00	IC	BD3841FS			IC	06
IC205	X7378A00	IC	NJM4565M(Te1)			アンプIC	
IC207	X7378A00	IC	NJM4565M(Te1)			アンプIC	
IC209	X0082A00	IC	LC72722PM		GE	IC	
IC211	XP844A00	IC	NJM4556AL			IC	02
IC286-288	XS790A00	IC	TC74HC4052AF MPX			ロジックIC	
IC289	XS790A00	IC	TC74HC4052AF MPX		J	ロジックIC	
IC290	X2904A00	IC	NJM2581M V1DEO AMP			アンプIC	06
IC291	XZ509A00	IC	TC74VHC04FT INVER			ロジックIC	01
PJ200	V7046800	JACK. PIN	6P			ピンジャック	
PJ200-201	V7046800	JACK. PIN	6P			ピンジャック	
PJ201	V7046800	JACK. PIN	6P			ピンジャック	
PJ202	V7189700	JACK. PIN	1P			ピンジャック	01
PJ202	V7189700	JACK. PIN	1P			ピンジャック	01
PJ203	V7046700	JACK. PIN	4P			ピンジャック	03
PJ203	V7046700	JACK. PIN	4P			ピンジャック	03
PJ204	WG674800	JACK. PIN	6P	559		ピンジャック	
PJ204	WG674900	JACK. PIN	4P	5950		ピンジャック	
PJ286	WG471900	JACK. PIN	6P			ピンジャック	
PJ286-287	WG471900	JACK. PIN	6P			ピンジャック	

* New Parts * 新規部品

RX-V559/HTR-5950/
DSP-AX559

P.C.B. FUNCTION

Ref. No.	Part No.	Description	Remarks	Markets	部 品 名	Rank
* PJ287	WG471900	JACK. PIN	6P		ピンジャック	
PN200	V9637500	PIN	L=70 #18		スタイルピン	
PN200-201	V9637500	PIN	L=70 #18		スタイルピン	
PN201-202	V9637500	PIN	L=70 #18		スタイルピン	
PN202-203	V9637500	PIN	L=70 #18		スタイルピン	
PN203-204	V9637500	PIN	L=70 #18		スタイルピン	
PN204-205	V9637500	PIN	L=70 #18		スタイルピン	
PN205-206	V9637500	PIN	L=70 #18		スタイルピン	
PN206	V9637500	PIN	L=70 #18		スタイルピン	
PN286	V9637500	PIN	L=70 #18		スタイルピン	
PN286	V9637500	PIN	L=70 #18		スタイルピン	
Q2000-2001	VZ725900	TR	2SD1938F S, T	559	トランジスタ	01
Q2003-2004	VZ725900	TR	2SD1938F S, T	559	トランジスタ	01
Q2006	iC181510	TR	2SC1815 Y		トランジスタ	01
Q2007	iA101510	TR	2SA1015 Y		トランジスタ	01
Q2008	iC174020	TR	2SC1740S QRS	GE	トランジスタ	01
Q2009	VZ725900	TR	2SD1938F S, T		トランジスタ	01
Q2010	iC181510	TR	2SC1815 Y		トランジスタ	01
Q2011	VZ725900	TR	2SD1938F S, T		トランジスタ	01
Q2012-2019	VD303700	TR	2SC3326 A, B		トランジスタ	01
R2016-2017			100Ω 1/16W J	559	チップ抵抗	
R2046-2049			10KΩ 1/16W J	559	チップ抵抗	
R2056-2057			220Ω 1/16W J	559	チップ抵抗	
R2059-2060			1KΩ 1/16W J	559	チップ抵抗	
R2064-2065			100KΩ 1/16W J	559	チップ抵抗	
R2067-2068			100KΩ 1/16W J	559	チップ抵抗	
R2091-2092	HF356560	R. CAR	5.6KΩ 1/2W		カーボン抵抗	
R2098-2099	HF356150	R. CAR	1.5KΩ 1/2W		カーボン抵抗	
R2104		R. CHP	100KΩ 1/16W J	GE	チップ抵抗	
R2105		R. CHP	33KΩ 1/16W J	GE	チップ抵抗	
R2111	HV754470	R. CAR. FP	47Ω 1/4W		不燃化カーボン抵抗	01
R2114		R. CHP	3.3KΩ 1/16W J	GE	チップ抵抗	
R2115	HV754470	R. CAR. FP	47Ω 1/4W		不燃化カーボン抵抗	01
R2118		R. CHP	22KΩ 1/16W J	GE	チップ抵抗	
R2127		R. CHP	100Ω 1/16W J	GE	チップ抵抗	
R2135-2136	HF356100	R. CAR	1KΩ 1/2W		カーボン抵抗	
R2137	HV753220	R. CAR. FP	2.2Ω 1/4W		不燃化カーボン抵抗	01
R2138		R. CHP	470Ω 1/16W J	GE	チップ抵抗	
R2139	HF356100	R. CAR	1KΩ 1/2W		カーボン抵抗	
R2145		R. CHP	470Ω 1/16W J	GE	チップ抵抗	
R2147		R. CHP	10KΩ 1/16W J	GE	チップ抵抗	
R2151		R. CHP	10KΩ 1/16W J	GE	チップ抵抗	
R2152	HV755220	R. CAR. FP	220Ω 1/4W		不燃化カーボン抵抗	01
R2153	HV755150	R. CAR. FP	150Ω 1/4W		不燃化カーボン抵抗	01
R2156	HF353220	R. CAR	2.2Ω 1/2W		カーボン抵抗	
R2159	HF353220	R. CAR	2.2Ω 1/2W		カーボン抵抗	
R2173-2174	HV755100	R. CAR. FP	100Ω 1/4W		不燃化カーボン抵抗	01
R2863-2874		R. CHP	100Ω 1/16W J	J	チップ抵抗	
R2878-2880		R. CHP	75Ω 1/16W J	J	チップ抵抗	
R2884	HV753220	R. CAR. FP	2.2Ω 1/4W		不燃化カーボン抵抗	01
R2895-2897		R. CHP	10KΩ 1/16W J	J	チップ抵抗	
ST286	V4040500	SCR. TERM	M3		スクリュー/ターミナル	01
* SW320	WB493700	VOLT. SELECT	R8140246	R	電圧切替器	
* SW320	WD073700	VOLT. SELECT	R8140254	L	電圧切替器	
XL200	V3930900	RSNR. CRY	4.332MHz	GE	水晶振動子	05

* New Parts * 新規部品

RX-V559/HTR-5950/
DSP-AX559

RX-V559/DSP-AX559

RX-V559/DSP-AX559 P.C.B. OPERATION

Ref. No.	Part No.	Description	Remarks	Markets	部 品 名	Rank	
	WG769900	P. C. B.	OPERATION	559	J	P C B オペレーション	
	WG770000	P. C. B.	OPERATION	559	UC	P C B オペレーション	
	WG770100	P. C. B.	OPERATION	559	R	P C B オペレーション	
	WG770200	P. C. B.	OPERATION	559	TK	P C B オペレーション	
	WG770300	P. C. B.	OPERATION	559	A	P C B オペレーション	
	WG770500	P. C. B.	OPERATION	559	GE	P C B オペレーション	
	WG770600	P. C. B.	OPERATION	559	L	P C B オペレーション	
	CB302	VQ045300	CN. BS. PIN	23P	559	FFCコネクター	01
	CB303	VG879900	CN. BS. PIN	2P	559	ベースピン	01
	CB304-305	WC050700	CLIP. FUSE	EYF-52BCY	559	ヒューズクリップ	01
	CB306-307	WC050700	CLIP. FUSE	EYF-52BCY	559	ヒューズクリップ	01
	CB308	VG879900	CN. BS. PIN	2P	559	ベースピン	01
	CB311	VB858400	CN. BS. PIN	5P	559	ベースピン	01
	CB312	LB919020	CN. BS. PIN	2P	559	ベース付ポスト	01
	CB331	LB918020	CN. BS. PIN	2P	559	ベース付ポスト	01
	C3000-3001	US063100	C. CE. CHP	1000pF 50V B	559	チップセラコン	01
	C3002	US135100	C. CE. CHP	0.1uF 16V	559	チップセラコン	01
	C3003-3006	US063100	C. CE. CHP	1000pF 50V B	559	チップセラコン	01
	C3007	UM397100	C. EL	10uF 16V	559	ケミコン	01
	C3008	UR866220	C. EL	2.2uF 50V	559	ケミコン	01
	C3009	US135100	C. CE. CHP	0.1uF 16V	559	チップセラコン	01
	C3010	US065100	C. CE. CHP	0.1uF 50V B	559	チップセラコン	
	C3011-3012	US063100	C. CE. CHP	1000pF 50V B	559	チップセラコン	01
	C3013	UR866220	C. EL	2.2uF 50V	559	ケミコン	01
	C3014	US064100	C. CE. CHP	0.01uF 50V B	559	チップセラコン	01
	C3015	WB687100	C. POL. MTL	0.047uF 400V	559	メタライズドポリコン	01
	C3015	WC041600	C. PP	0.022uF 630V	559	P Pコン	01
	C3016	UR866100	C. EL	1uF 50V	559	ケミコン	01
	C3017	US135100	C. CE. CHP	0.1uF 16V	559	チップセラコン	01
	C3018	UA653470	C. MYLAR	4700pF 50V J	559	マイラーコン	01
	C3019	US135100	C. CE. CHP	0.1uF 16V	559	チップセラコン	01
	C3020	UA653100	C. MYLAR	1000pF 50V J	559	マイラーコン	03
	C3021	UM417100	C. EL	10uF 50V	559	ケミコン	01
	C3022	UM388330	C. EL	330uF 6.3V	559	ケミコン	01
	C3023	US135100	C. CE. CHP	0.1uF 16V	559	チップセラコン	01
	C3024-3026	US062100	C. CE. CHP	100pF 50V B	559	チップセラコン	01
	C3027	US135100	C. CE. CHP	0.1uF 16V	559	チップセラコン	01
	C3029	WB696300	C. POL. MTL	0.1uF 400V	559	メタライズドポリコン	
	C3029	WD257600	C. PP	0.047uF 800V	559	P Pコン	
	C3030	V6185300	C. CE. SAFTY	0.01uF 275V	559	規格認定コン	
	C3031	US135100	C. CE. CHP	0.1uF 16V	559	チップセラコン	01
	C3033	UR239330	C. EL	3300uF 16V	559	ケミコン	02
	C3033	UR269330	C. EL	3300uF 50V	559	ケミコン	
	C3034	WE102900	C. PP	0.01uF 100V	559	P Pコン	
	C3035-3036	US135100	C. CE. CHP	0.1uF 16V	559	チップセラコン	01
	C3037	US064100	C. CE. CHP	0.01uF 50V B	559	チップセラコン	01
	C3038-3039	UA653100	C. MYLAR	1000pF 50V J	559	マイラーコン	03
	C3040	UA654100	C. MYLAR	0.01uF 50V J	559	マイラーコン	01
	C3041	UA653100	C. MYLAR	1000pF 50V J	559	マイラーコン	03
	C3042	US135100	C. CE. CHP	0.1uF 16V	559	チップセラコン	01
	C3043-3044	US062220	C. CE. CHP	220pF 50V B	559	チップセラコン	01
	C3045-3046	US135100	C. CE. CHP	0.1uF 16V	559	チップセラコン	01
	C3047	US064100	C. CE. CHP	0.01uF 50V B	559	チップセラコン	01
	D3000	VT332900	D1ODE	1SS355	559	ダイオード	01
	D3001	V2598200	LED	S1R-505ST	559	L E D	
	D3003-3004	VT332900	D1ODE	1SS355	559	ダイオード	01
	D3005	VU990500	D1ODE. ZENR	MA8030-L 2.9V	559	ツェナーダイオード	01
	D3006	VU993800	D1ODE. ZENR	MA8068-M 6.8V	559	ツェナーダイオード	01
	D3007	VU995400	D1ODE. ZENR	MA8100-M 10V	559	ツェナーダイオード	
	D3008-3012	VT332900	D1ODE	1SS355	559	ダイオード	01

* New Parts * 新規部品

RX-V559/DSP-AX559

HTR-5950

RX-V559/DSP-AX559 P.C.B. OPERATION & HTR-5950 P.C.B. OPERATION

Ref. No.	Part No.	Description	Remarks	Markets	部 品 名	Rank
D3015	VU995000	DIODE. ZENR	MA8091-M 9.1V	559	JUCTKAGEL	ツェナーダイオード
D3015	VU994700	DIODE. ZENR	MA8082-H 8.5V	559	R	ツェナーダイオード
D3016	V4756800	DIODE	S1NB60 1.0A 600V	559		D i スタック
D3017	VT332900	DIODE	1SS355	559		ダイオード
D3018	VR253700	DIODE. BRG	S1NB20 1A 200V	559		D I ブリッジ X 4
D3019-3020	VU171500	DIODE. ZENR	UDZ 3.6BTE-17 3.6V	559		ツェナーダイオード
D3021	VU995000	DIODE. ZENR	MA8091-M 9.1V	559		ツェナーダイオード
D3022-3028	VT332900	DIODE	1SS355	559		ダイオード
F3000	WG410700	FUSE	8A 125V	559	UC	ヒューズ
F3000	VT942900	FUSE	T2.5A 250V	559	GE	ヒューズ
F3001	WG410700	FUSE	8A 125V	559	JUCR	ヒューズ
F3001	KB000790	FUSE	T4A 250V	559	TKAGEL	ヒューズ
IC300	V8100500	PHOT. CPL	TLP421 GR	559		フォトカブラ
IC301	X6386A00	IC	M66003-0131FP	559		I C
IC302	iG001180	IC	TC4013BP FF	559		ロジック I C
IC303	V8100500	PHOT. CPL	TLP421 GR	559		フォトカブラ
JK300	V9408200	JACK. PHONE	MSJ-064-05B GR	559		ホーンジャック
JK302	WG514200	JACK. MNI	JY-3535+01-090G	559		ミニジャック
PJ300	V7190100	JACK. PIN	3P	559		ピンジャック
PN331	V9637500	PIN	L=70 #18	559		スタイルピン
Q3000-3001	VV556400	TR	2SC2412K Q, R, S	559		トランジスタ
Q3002	VV655700	TR. DGT	DTC144EKA	559		デジタルトランジスタ
Q3003	iC181510	TR	2SC1815 Y	559		トランジスタ
Q3004	VV556400	TR	2SC2412K Q, R, S	559		トランジスタ
Q3006	iC181510	TR	2SC1815 Y	559		トランジスタ
Q3007	WC741200	FET	2SK3850	559		F E T
Q3008-3009	VV556400	TR	2SC2412K Q, R, S	559		トランジスタ
R3031	V6730000	R. CAR.	2.2MΩ 1/2W	559	UC	放電抵抗
R3034	HF356220	R. CAR	2.2KΩ 1/2W	559		カーボン抵抗
RY301	V6434900	RELAY	DC DLS12D1-0(M)	559		リレー 12V TV-8
ST300	V4040500	SCR. TERM	M3	559		スクリュー/ターミナル
ST301	WA246200	SCR. TERM	3.5	559		スクリューターミナル
ST302	V4040500	SCR. TERM	M3	559		スクリュー/ターミナル
SW300	V9597100	SW. RT. ENC	EC12E2460802	559		ロータリーエンコーダ
SW301-302	V9266400	SW. RT. ENC	XREB12105PVB25F	559		ロータリーエンコーダ
SW303-316	WD483100	SW. TACT	SKRGAAD010	559		タクト SW
SW318-319	WD483100	SW. TACT	SKRGAAD010	559		タクト SW
SW321	WF875900	SW. PUSH	SPUN127100	559		プッシュSW
T3000	XW605A00	TRANS. PWR		559	J	電源トランス
T3000	XW606A00	TRANS. PWR		559	UC	電源トランス
T3000	X6351A00	TRANS. PWR		559	R	電源トランス
T3000	XW608A00	TRANS. PWR		559	TKAGEL	電源トランス
TE300	VU543100	OUTLET. AC	2P	559	JUC	A C アウトレット
TE300	V5867400	OUTLET. AC	2P AC-182-GB-11V	559	RTK	A C アウトレット
TE300	VT915000	OUTLET. AC	1P	559	A	A C アウトレット
TE300	VU543400	OUTLET. AC	2P	559	GEL	A C アウトレット
U3000	V8210200	L. DTCT	GP1UD271XK	559		リモコン受光ユニット
V3000	WG474000	FL. DSPLY	HNA-17MM03T	559		蛍光表示管
	V6880300	SHEET		559		シート/F L
	V6007100	SPACER. FL	4.6/10/32	559		スペーサ F L
	WG771400	P. C. B.	OPERATION	5950	UC	P C B オペレーション
	WG956400	P. C. B.	OPERATION	5950	T	P C B オペレーション
	WG771500	P. C. B.	OPERATION	5950	A	P C B オペレーション
CB303	VG879900	CN. BS. PIN	2P	5950		ベースピン
CB304-305	WC050700	CLIP. FUSE	EYF-52BCY	5950	UC	ヒューズクリップ
CB306-307	WC050700	CLIP. FUSE	EYF-52BCY	5950		ヒューズクリップ
CB308	VG879900	CN. BS. PIN	2P	5950		ベースピン

* New Parts * 新規部品

RX-V559/HTR-5950/
DSP-AX559

HTR-5950

HTR-5950 P.C.B. OPERATION

Ref. No.	Part No.	Description	Remarks	Markets	部 品 名	Rank	
CB309	VM689000	CN. BS. PIN	23P	5950		F F C コネクター	02
CB310	LB919020	CN. BS. PIN	2P	5950		ベース付ポスト	01
CB331	LB918020	CN. BS. PIN	2P	5950		ベース付ポスト	01
C3000	US135100	C. CE. CHP	0.1uF 16V	5950		チップセラコン	01
C3001-3004	US063100	C. CE. CHP	1000pF 50V B	5950		チップセラコン	01
C3005	UM397100	C. EL	10uF 16V	5950		ケミコン	01
C3006	US135100	C. CE. CHP	0.1uF 16V	5950		チップセラコン	01
C3007	US065100	C. CE. CHP	0.1uF 50V B	5950		チップセラコン	01
C3008	UR866220	C. EL	2.2uF 50V	5950		ケミコン	01
C3009-3010	US135100	C. CE. CHP	0.1uF 16V	5950		チップセラコン	01
C3011	UM388330	C. EL	330uF 6.3V	5950		ケミコン	01
C3012	US135100	C. CE. CHP	0.1uF 16V	5950		チップセラコン	01
C3013	UR866220	C. EL	2.2uF 50V	5950		ケミコン	01
C3014	US064100	C. CE. CHP	0.01uF 50V B	5950		チップセラコン	01
C3015	WB687100	C. POL. MTL	0.047uF 400V	5950	UC	メタライズドポリコン	01
C3015	WC041600	C. PP	0.022uF 630V	5950	TA	P P コン	01
C3016	UR866100	C. EL	1uF 50V	5950		ケミコン	01
C3017	US062100	C. CE. CHP	100pF 50V B	5950		チップセラコン	01
C3018	UA653470	C. MYLAR	4700pF 50V J	5950		マイラーコン	01
C3019	US135100	C. CE. CHP	0.1uF 16V	5950		チップセラコン	01
C3020	UA653100	C. MYLAR	1000pF 50V J	5950		マイラーコン	03
C3021-3022	US062100	C. CE. CHP	100pF 50V B	5950		チップセラコン	01
C3024-3026	US135100	C. CE. CHP	0.1uF 16V	5950		チップセラコン	01
C3027	US064100	C. CE. CHP	0.01uF 50V B	5950		チップセラコン	01
C3028	UA653100	C. MYLAR	1000pF 50V J	5950		マイラーコン	03
C3029	WB696300	C. POL. MTL	0.1uF 400V	5950	UC	メタライズドポリコン	01
C3029	WD257600	C. PP	0.047uF 800V	5950	TA	P P コン	01
C3030	V6185300	C. CE. SAFTY	0.01uF 275V	5950		規格認定コン	01
C3031-3032	UA653100	C. MYLAR	1000pF 50V J	5950		マイラーコン	03
C3033	UR239330	C. EL	3300uF 16V	5950		ケミコン	02
C3034	WE102900	C. PP	0.01uF 100V	5950		P P コン	01
C3035	UA654100	C. MYLAR	0.01uF 50V J	5950		マイラーコン	01
C3036-3037	US135100	C. CE. CHP	0.1uF 16V	5950		チップセラコン	01
C3043-3044	US063680	C. CE. CHP	6800pF 50V B	5950		チップセラコン	01
C3046	US135100	C. CE. CHP	0.1uF 16V	5950		チップセラコン	01
C3047	US064100	C. CE. CHP	0.01uF 50V B	5950		チップセラコン	01
D3000-3001	VT332900	D I O D E	1SS355	5950		ダイオード	01
D3002	VU171500	D I O D E. ZENR	UDZ 3.6BTE-17 3.6V	5950		ツェナーダイオード	01
D3003-3004	VT332900	D I O D E	1SS355	5950		ダイオード	01
D3005	VU990500	D I O D E. ZENR	MA8030-L 2.9V	5950		ツェナーダイオード	01
D3006	VU993800	D I O D E. ZENR	MA8068-M 6.8V	5950		ツェナーダイオード	01
D3007	VU995400	D I O D E. ZENR	MA8100-M 10V	5950		ツェナーダイオード	01
D3008	VT332900	D I O D E	1SS355	5950		ダイオード	01
D3009	VU171500	D I O D E. ZENR	UDZ 3.6BTE-17 3.6V	5950		ツェナーダイオード	01
D3010	VU995000	D I O D E. ZENR	MA8091-M 9.1V	5950		ツェナーダイオード	01
D3011-3012	VT332900	D I O D E	1SS355	5950		ダイオード	01
D3015	VU995000	D I O D E. ZENR	MA8091-M 9.1V	5950		ツェナーダイオード	01
D3016	V4756800	D I O D E	S1NB60 1.0A 600V	5950		D i スタック	01
D3017	VT332900	D I O D E	1SS355	5950		ダイオード	01
D3018	VR253700	D I O D E. BRG	S1NB20 1A 200V	5950		D l ブリッジ X 4	02
D3019-3020	VT332900	D I O D E	1SS355	5950		ダイオード	01
D3026-3027	VT332900	D I O D E	1SS355	5950		ダイオード	01
F3000	WG410700	F U S E	8A 125V	5950	UC	ヒューズ	01
F3001	WG410700	F U S E	8A 125V	5950	UC	ヒューズ	01
F3001	KB000790	F U S E	T4A 250V	5950	TA	ヒューズ	01
IC300	V8100500	P H O T. C P L	TLP421 GR	5950		フォトカプラ	01
IC301	X6386A00	I C	M66003-0131FP	5950		I C	07
IC302	iG001180	I C	TC4013BP FF	5950		ロジック I C	05
IC303	V8100500	P H O T. C P L	TLP421 GR	5950		フォトカプラ	01
JK300	V9408200	J A C K. P H O N E	MSJ-064-05B GR	5950		ホーンジャック	03

* New Parts * 新規部品

RX-V559/DSP-AX559

HTR-5950

HTR-5950 P.C.B. OPERATION & P.C.B. MAIN

Ref. No.	Part No.	Description	Remarks	Markets	部 品 名	Rank	
* JK302	WG514200	JACK. MNI	JY-3535+01-090G	5950		ミニジャック	
PJ300	V7190100	JACK. PIN	3P	5950		ピンジャック	
PN331	V9637500	PIN	L=70 #18	5950		スタイルピン	
Q3000-3001	VV556400	TR	2SC2412K Q, R, S	5950		トランジスタ	01
Q3002	VV655700	TR. DGT	DTC144EKA	5950		デジタルトランジスタ	01
Q3003	iC181510	TR	2SC1815 Y	5950		トランジスタ	01
Q3004-3005	VV556400	TR	2SC2412K Q, R, S	5950		トランジスタ	01
Q3006	iC181510	TR	2SC1815 Y	5950		トランジスタ	01
Q3007	WC741200	FET	2SK3850	5950		F E T	
Q3008	VV556400	TR	2SC2412K Q, R, S	5950		トランジスタ	01
R3031	V6730000	R. CAR.	2. 2MΩ 1/2W	5950	UC	放電抵抗	01
* ⚠ RY301	V6434900	RELAY	DC DLS12D1-0(M)	5950		リレー 12V TV-8	03
ST300	V4040500	SCR. TERM	M3	5950		スクリュー/ターミナル	01
ST316	WA246200	SCR. TERM	3. 5	5950		スクリューターミナル	
ST318	WA246200	SCR. TERM	3. 5	5950		スクリューターミナル	
SW300	V9597100	SW. RT. ENC	EC12E2460802	5950		ロータリーエンコーダ	04
SW301	V9266400	SW. RT. ENC	XREB12105PVB25F	5950		ロータリーエンコーダ	02
SW302	WD483100	SW. TACT	SKRGAAD010	5950		タクト SW	01
SW304	WD483100	SW. TACT	SKRGAAD010	5950		タクト SW	01
SW306	WD483100	SW. TACT	SKRGAAD010	5950		タクト SW	01
SW309-319	WD483100	SW. TACT	SKRGAAD010	5950		タクト SW	01
SW321-324	WD483100	SW. TACT	SKRGAAD010	5950		タクト SW	01
* ⚠ T3000	XW606A00	TRANS. PWR		5950	UC	電源トランス	
* ⚠ T3000	XW608A00	TRANS. PWR		5950	TA	電源トランス	
TE300	VU543100	OUTLET. AC	2P	5950	UC	ACアウトレット	03
TE300	V5867400	OUTLET. AC	2P	5950	T	ACアウトレット	
TE300	VT915000	OUTLET. AC	1P	5950	A	ACアウトレット	06
U3000	V8210200	L. DTCT	GP1UD271XK	5950		リモコン受光ユニット	03
* V3000	WG473900	FL. DSPLY	17-BT-XXGNK	5950		蛍光表示管	
	V6880300	SHEET		5950		シート/FL	
	V6007100	SPACER. FL	4. 6/10/32	5950		スペーサ FL	
* * * * *	WG700000	P. C. B.	MAIN	559	JRTA	P C B メイン	
	WG700100	P. C. B.	MAIN	559	UC	P C B メイン	
	WG700200	P. C. B.	MAIN	559	KGEL	P C B メイン	
	WG701000	P. C. B.	MAIN	5950	UC	P C B メイン	
	WG701100	P. C. B.	MAIN	5950	TA	P C B メイン	
CB103	LB932060	CN. BS. PIN	6P			ベースポスト	01
CB104	LB918100	CN. BS. PIN	10P			ベース付ポスト	02
CB105	LB918030	CN. BS. PIN	3P		UC	ベース付ポスト	01
CB113	V7827500	SOCKET	8P SE TUC SERIES			コネクタースocket	
CB114	V7825800	CN	8P TE TUC SERIES			コネクタープラグ	
CB115	V7825700	CN	7P TE TUC SERIES			コネクタープラグ	
CB116	V7827400	SOCKET	7P TE TUC SERIES			コネクタースocket	
C1000	UR238100	C. EL	100uF 16V			ケミコン	
C1001-1002	UR066470	C. EL	4. 7uF 50V			ケミコン	
C1003-1004	UR066470	C. EL	4. 7uF 50V			ケミコン	01
C1005	UR066470	C. EL	4. 7uF 50V			ケミコン	
C1006	UR066470	C. EL	4. 7uF 50V			ケミコン	01
C1007	UR237100	C. EL	10uF 16V			ケミコン	
C1008	UR248100	C. EL	100uF 25V			ケミコン	
C1009	UT652100	C. PP	100pF 100V			PPコン	01
C1010	UA652220	C. MYLAR	220pF 50V J			マイラーコン	01
C1011	UT652100	C. PP	100pF 100V			PPコン	01
C1012	UA652220	C. MYLAR	220pF 50V J			マイラーコン	01
C1013	UA652100	C. MYLAR	100pF 50V J			マイラーコン	01
C1014	UA652220	C. MYLAR	220pF 50V J			マイラーコン	01
C1015	UA652100	C. MYLAR	100pF 50V J			マイラーコン	01

* New Parts * 新規部品

RX-V559/DSP-AX559

HTR-5950

P.C.B. MAIN

Ref. No.	Part No.	Description	Remarks	Markets	部 品 名	Rank
C1016	UA652220	C. MYLAR	220pF 50V J		マイラーコン	01
C1017	UT652100	C. PP	100pF 100V		PPコン	01
C1018	UA652220	C. MYLAR	220pF 50V J		マイラーコン	01
C1019	UA652100	C. MYLAR	100pF 50V J		マイラーコン	01
C1020	UA652220	C. MYLAR	220pF 50V J		マイラーコン	01
C1021	UA653330	C. MYLAR	3300pF 50V J		マイラーコン	01
C1022-1023	UT653330	C. PP	3300pF 100V		PPコン	03
C1024-1025	UA653330	C. MYLAR	3300pF 50V J		マイラーコン	01
C1026	UT653330	C. PP	3300pF 100V		PPコン	03
C1027	UR268100	C. EL	100uF 50V		ケミコン	
C1028	UR837470	C. EL	47uF 16V		ケミコン	01
C1029	UT654100	C. PP	0.01uF 100V		PPコン	01
C1030-1031	UR268100	C. EL	100uF 50V		ケミコン	
C1032-1033	UR837470	C. EL	47uF 16V		ケミコン	01
C1034-1039	WG211700	C. CE	22pF 500V		セラコン	
C1040-1041	UR297100	C. EL	10uF 100V		ケミコン	
C1042	UT652150	C. PP	150pF 100V		PPコン	01
C1043	UR297100	C. EL	10uF 100V		ケミコン	
C1044-1045	UT652150	C. PP	150pF 100V		PPコン	01
C1046	UR297100	C. EL	10uF 100V		ケミコン	
C1047-1048	UT652150	C. PP	150pF 100V		PPコン	01
C1049	UR297100	C. EL	10uF 100V		ケミコン	
C1050-1051	UT652150	C. PP	150pF 100V		PPコン	01
C1052	UR297100	C. EL	10uF 100V		ケミコン	
C1053-1054	UT652150	C. PP	150pF 100V		PPコン	01
C1055	UR297100	C. EL	10uF 100V		ケミコン	
C1056-1057	UT652150	C. PP	150pF 100V		PPコン	01
C1058	UR297100	C. EL	10uF 100V		ケミコン	
C1059	UT652150	C. PP	150pF 100V		PPコン	01
C1060	UR297100	C. EL	10uF 100V		ケミコン	
C1061-1065	VR324700	C. MYLAR	0.022uF 100V		マイラーコン	
C1066	UT654220	C. PP	0.022uF 100V		PPコン	01
C1067	UR818100	C. EL	100uF 6.3V		ケミコン	01
C1068-1069	WE100900	C. PP	220pF 630V		PPコン	
C1070	UR866470	C. EL	4.7uF 50V		ケミコン	01
C1071	WG601900	C. EL	10000uF 16V		ケミコン	
C1072	UR867470	C. EL	47uF 50V		ケミコン	01
C1073	VF467000	C. CE. TUBLR	1000pF 50V	559	円筒セラコン	01
C1074	UR858100	C. EL	100uF 35V		ケミコン	01
C1075	UR249470	C. EL	4700uF 25V		ケミコン	
C1076	UR249220	C. EL	2200uF 25V		ケミコン	
C1077	WG602000	C. EL	15000uF 16V		ケミコン	
C1078	WG601700	C. EL	4700uF 16V		ケミコン	
C1079	VF467000	C. CE. TUBLR	1000pF 50V	559	円筒セラコン	01
C1080	VF467300	C. CE. TUBLR	0.01uF 16V	559	円筒セラコン	01
C1081	UR866470	C. EL	4.7uF 50V		ケミコン	01
C1082-1083	VR325200	C. MYLAR	0.022uF 100V		マイラーコン	01
C1084-1085	WG416300	C. EL	10000uF 71V		ケミコン	
C1086	VF467300	C. CE. TUBLR	0.01uF 16V	559	円筒セラコン	01
C1087-1088	VR325400	C. MYLAR	0.1uF 100V		マイラーコン	01
C1089	VF467300	C. CE. TUBLR	0.01uF 16V	559	円筒セラコン	01
C1090	UR268330	C. EL	330uF 50V		ケミコン	
C1091	UR268100	C. EL	100uF 50V		ケミコン	
C1092-1093	UA654220	C. MYLAR	0.022uF 50V J		マイラーコン	01
C1094-1095	VR325400	C. MYLAR	0.1uF 100V		マイラーコン	01
C1096	WG602000	C. EL	15000uF 16V		ケミコン	
C1097	UA654100	C. MYLAR	0.01uF 50V J		マイラーコン	01
C1098	WG602000	C. EL	15000uF 16V		ケミコン	
C1099	UA654100	C. MYLAR	0.01uF 50V J		マイラーコン	01
C1100-1101	VR325400	C. MYLAR	0.1uF 100V		マイラーコン	01

* New Parts * 新規部品

RX-V559/DSP-AX559

HTR-5950

P.C.B. MAIN

Ref. No.	Part No.	Description	Remarks	Markets	部 品 名	Rank
C1102	UA654100	C. MYLAR	0.01uF 50V J		マイラーコン	01
C1103	UA354100	C. MYLAR	0.01uF 50V		マイラーコン	01
C1104-1107	WA747600	C. MYLAR	1000pF 100V		マイラーコン	01
C1108	UA654220	C. MYLAR	0.022uF 50V J		マイラーコン	01
C1109	VE326000	C. MYLAR	0.1uF 50V	UC	マイラーコン	01
C1110	UA354100	C. MYLAR	0.01uF 50V		マイラーコン	01
C1111	UA654220	C. MYLAR	0.022uF 50V J		マイラーコン	01
C1112	VR325400	C. MYLAR	0.1uF 100V		マイラーコン	01
C1113	UA354100	C. MYLAR	0.01uF 50V		マイラーコン	01
C1114	UA654220	C. MYLAR	0.022uF 50V J		マイラーコン	01
C1115-1118	UA653470	C. MYLAR	4700pF 50V J		マイラーコン	01
C1119	UA654220	C. MYLAR	0.022uF 50V J		マイラーコン	01
C1120	VJ599100	C. CE. TUBLR	0.1uF 50V	UC	円筒セラコン	01
C1121	UR237470	C. EL	47uF 16V	UC	ケミコン	
C1122-1123	UR266100	C. EL	1uF 50V		ケミコン	
C1124	VJ599100	C. CE. TUBLR	0.1uF 50V		円筒セラコン	01
C1126-1127	UR266100	C. EL	1uF 50V		ケミコン	
C1129-1130	UR266100	C. EL	1uF 50V		ケミコン	
C1131	UR238100	C. EL	100uF 16V		ケミコン	
C1132	UR266100	C. EL	1uF 50V		ケミコン	
C1135-1137	UR266100	C. EL	1uF 50V		ケミコン	
C1138	UR238100	C. EL	100uF 16V		ケミコン	
C1140	UR266100	C. EL	1uF 50V		ケミコン	
C1141	UR238100	C. EL	100uF 16V		ケミコン	
C1150	UR237100	C. EL	10uF 16V	UC	ケミコン	
D1000	VG440700	DIODE. ZENR	MTZJ15A 15V		ツェナーダイオード	
D1001-1016	VD631600	DIODE	1SS133, 176		ダイオード	01
D1017-1018	VG435500	DIODE. ZENR	MTZJ2. 4B 2.4V		ツェナーダイオード	01
D1019-1030	VN008700	DIODE	1SS270A		ダイオード	01
D1031	VD631600	DIODE	1SS133, 176	559	ダイオード	01
D1032	VG443200	DIODE. ZENR	MTZJ30A 30V		ツェナーダイオード	01
D1033-1034	VD631600	DIODE	1SS133, 176	559	ダイオード	01
D1035	WA653100	DIODE. BRG	KBP103G 1.0A 200V		ダイオードブリッジ	02
D1036	WF300200	DIODE. BRG	TS4B03G C2		ダイオードブリッジ	
D1037-1039	VG442900	DIODE. ZENR	MTZJ27B 27V		ツェナーダイオード	01
D1040	WA653200	DIODE. BRG	TS6P03G 6.0A 200V		ダイオードブリッジ	04
D1041-1042	VS997800	DIODE	1T2		ダイオード	01
D1043	VG442900	DIODE. ZENR	MTZJ27B 27V		ツェナーダイオード	01
D1044-1045	VS997800	DIODE	1T2		ダイオード	01
D1046	WA653100	DIODE. BRG	KBP103G 1.0A 200V		ダイオードブリッジ	02
D1047	VG442900	DIODE. ZENR	MTZJ27B 27V		ツェナーダイオード	01
D1048	V4269600	DIODE. BRG	D2SBA20 1.5A 200V		ダイオードブリッジ	
D1049	VG442900	DIODE. ZENR	MTZJ27B 27V		ツェナーダイオード	01
D1050	VG440800	DIODE. ZENR	MTZJ15B 15V		ツェナーダイオード	01
D1051	VU647200	DIODE. SHOT	RB441Q-40 T-77		ショットキーダイオード	01
D1052	VU647200	DIODE. SHOT	RB441Q-40 T-77		ショットキーダイオード	01
D1053-1058	VG437500	DIODE. ZENR	MTZJ5. 1C 5. 1V		ツェナーダイオード	01
D1060	VG437500	DIODE. ZENR	MTZJ5. 1C 5. 1V		ツェナーダイオード	01
D1061	VG435500	DIODE. ZENR	MTZJ2. 4B 2.4V		ツェナーダイオード	01
G1000	V5995800	PLATE. GND			アースプレート	
IC100	X6143A00	IC	NJM2388F05 5.0V		電源IC	
IC101	X0515A00	IC	LM61C1Z THERMAL		電源IC	03
IC102	X6143A00	IC	NJM2388F05 5.0V		電源IC	
IC103	XE436A00	IC	NJM79M05FA		IC	03
IC104	XJ608A00	IC	NJM7812FA		IC	02
IC105	XD343A00	IC	NJM79M12FA		IC	03
IC106	X6143A00	IC	NJM2388F05 5.0V		電源IC	
IC107	X6248A00	IC	NJM2388F33		電源IC	04
IC110	XJ607A00	IC	NJM7805FA 5V		IC	02
JK100-102	V9435700	JACK. MNI	MSJ-035-12APC	559	モノラル ミニジャック	01

* New Parts * 新規部品

RX-V559/HTR-5950/
DSP-AX559

RX-V559/DSP-AX559

HTR-5950

P.C.B. MAIN

Ref. No.	Part No.	Description	Remarks	Markets	部 品 名	Rank
PN101-107	V9637500	PIN	L=70 #18		スタイルピン	
Q1000	VP872600	TR	2SA1708 S,T		トランジスタ	01
Q1001-1012	VP883100	TR	2SC1890A D,E		トランジスタ	01
Q1013-1018	V3966800	TR	2SA949 O,Y		トランジスタ	02
⚠ Q1019-1024	VK432900	TR	2SD1915F S,T		トランジスタ	01
Q1025-1030	VR325600	TR	2SC2229 O,Y		トランジスタ	01
Q1031	WC398400	TR	2N5551C-AT		トランジスタ	
Q1032	WC397700	TR	2N5401C-AT		トランジスタ	
Q1033	V4096100	TR	2SC4614 S,T		トランジスタ	02
Q1034	V4096000	TR	2SA1770 S,T		トランジスタ	03
Q1035	V4096100	TR	2SC4614 S,T		トランジスタ	02
Q1036	V4096000	TR	2SA1770 S,T		トランジスタ	03
Q1037	V4096100	TR	2SC4614 S,T		トランジスタ	02
Q1038	V4096000	TR	2SA1770 S,T		トランジスタ	03
⚠ Q1039	V4096100	TR	2SC4614 S,T		トランジスタ	02
⚠ Q1040	V4096000	TR	2SA1770 S,T		トランジスタ	03
Q1041	V4096100	TR	2SC4614 S,T		トランジスタ	02
Q1042	V4096000	TR	2SA1770 S,T		トランジスタ	03
Q1043	V4096100	TR	2SC4614 S,T		トランジスタ	02
Q1044	V4096000	TR	2SA1770 S,T		トランジスタ	03
Q1045-1046	VC614000	TR	2SB1274 Q,R,S		トランジスタ	02
Q1047	WC398400	TR	2N5551C-AT		トランジスタ	
⚠ Q1048A	iX630850	TR	2SA1695 O,P,Y		トランジスタ	04
⚠ Q1048C	iX630860	TR	2SC4468 O,P,Y		トランジスタ	04
⚠ Q1049A	iX630850	TR	2SA1695 O,P,Y		トランジスタ	04
⚠ Q1049C	iX630860	TR	2SC4468 O,P,Y		トランジスタ	04
⚠ Q1050A	iX630850	TR	2SA1695 O,P,Y		トランジスタ	04
⚠ Q1050C	iX630860	TR	2SC4468 O,P,Y		トランジスタ	04
⚠ Q1051A	iX630850	TR	2SA1695 O,P,Y		トランジスタ	04
⚠ Q1051C	iX630860	TR	2SC4468 O,P,Y		トランジスタ	04
⚠ Q1052A	iX630850	TR	2SA1695 O,P,Y		トランジスタ	04
⚠ Q1052C	iX630860	TR	2SC4468 O,P,Y		トランジスタ	04
⚠ Q1053A	iX630850	TR	2SA1695 O,P,Y		トランジスタ	04
⚠ Q1053C	iX630860	TR	2SC4468 O,P,Y		トランジスタ	04
Q1060-1065	WC398400	TR	2N5551C-AT		トランジスタ	
⚠ Q1066	WC397700	TR	2N5401C-AT		トランジスタ	
Q1067	iC181510	TR	2SC1815 Y		トランジスタ	01
Q1068	iA101510	TR	2SA1015 Y		トランジスタ	01
Q1069	VP872600	TR	2SA1708 S,T	559	トランジスタ	01
Q1070	VG722000	TR. DGT	DTC144ES	559	デジタルトランジスタ	01
Q1071-1076	VP872700	TR	2SC4488 S,T		トランジスタ	01
R1006-1007	HF356100	R. CAR	1KΩ 1/2W		カーボン抵抗	
R1011	HF356100	R. CAR	1KΩ 1/2W		カーボン抵抗	
R1019	HV756100	R. CAR. FP	1KΩ 1/4W		不燃化カーボン抵抗	01
R1040-1041	HF355330	R. CAR	330Ω 1/2W		カーボン抵抗	
R1044	HF355330	R. CAR	330Ω 1/2W		カーボン抵抗	
R1045	HF356120	R. CAR	1.2KΩ 1/2W		カーボン抵抗	
R1047-1048	HF356120	R. CAR	1.2KΩ 1/2W		カーボン抵抗	
R1052-1054	HF357330	R. CAR	33KΩ 1/2W		カーボン抵抗	
R1057-1062	HV755100	R. CAR. FP	100Ω 1/4W		不燃化カーボン抵抗	01
R1064	HF353220	R. CAR	2.2Ω 1/2W		カーボン抵抗	
R1065-1067	HF355470	R. CAR	470Ω 1/2W		カーボン抵抗	
R1084	HL006270	R. MTL. OXD	2.7KΩ 1/2W		酸化金属被膜抵抗	
R1085	HL005470	R. MTL. OXD	470Ω 1/2W		酸化金属被膜抵抗	
R1086	HL005820	R. MTL. OXD	820Ω 1/2W		酸化金属被膜抵抗	
R1087	HL006270	R. MTL. OXD	2.7KΩ 1/2W		酸化金属被膜抵抗	
R1088	HL005470	R. MTL. OXD	470Ω 1/2W		酸化金属被膜抵抗	
R1089	HL005820	R. MTL. OXD	820Ω 1/2W		酸化金属被膜抵抗	
R1090	HL006270	R. MTL. OXD	2.7KΩ 1/2W		酸化金属被膜抵抗	
R1091	HL005470	R. MTL. OXD	470Ω 1/2W		酸化金属被膜抵抗	

* New Parts * 新規部品

RX-V559/DSP-AX559

HTR-5950

P.C.B. MAIN

Ref. No.	Part No.	Description	Remarks	Markets	部 品 名	Rank
R1092	HL005820	R. MTL. OXD	820Ω 1/2W		酸化金属被膜抵抗	
R1093	HL006270	R. MTL. OXD	2.7KΩ 1/2W		酸化金属被膜抵抗	
R1094	HL005470	R. MTL. OXD	470Ω 1/2W		酸化金属被膜抵抗	
R1095	HL005820	R. MTL. OXD	820Ω 1/2W		酸化金属被膜抵抗	
R1096	HL006270	R. MTL. OXD	2.7KΩ 1/2W		酸化金属被膜抵抗	
R1097	HL005470	R. MTL. OXD	470Ω 1/2W		酸化金属被膜抵抗	
R1098	HL005820	R. MTL. OXD	820Ω 1/2W		酸化金属被膜抵抗	
R1099	HL006270	R. MTL. OXD	2.7KΩ 1/2W		酸化金属被膜抵抗	
R1100	HL005470	R. MTL. OXD	470Ω 1/2W		酸化金属被膜抵抗	
R1101	HL005820	R. MTL. OXD	820Ω 1/2W		酸化金属被膜抵抗	
R1104	HL006100	R. MTL. OXD	1KΩ 1/2W		酸化金属被膜抵抗	
R1105	HV755100	R. CAR. FP	100Ω 1/4W		不燃化カーボン抵抗	01
R1106	HL006100	R. MTL. OXD	1KΩ 1/2W		酸化金属被膜抵抗	
R1107	HV755100	R. CAR. FP	100Ω 1/4W		不燃化カーボン抵抗	01
R1108	HL006100	R. MTL. OXD	1KΩ 1/2W		酸化金属被膜抵抗	
R1109	HV755100	R. CAR. FP	100Ω 1/4W		不燃化カーボン抵抗	01
R1110	HL006100	R. MTL. OXD	1KΩ 1/2W		酸化金属被膜抵抗	
R1111	HV755100	R. CAR. FP	100Ω 1/4W		不燃化カーボン抵抗	01
R1112	HL006100	R. MTL. OXD	1KΩ 1/2W		酸化金属被膜抵抗	
R1113	HV755100	R. CAR. FP	100Ω 1/4W		不燃化カーボン抵抗	01
R1114	HL006100	R. MTL. OXD	1KΩ 1/2W		酸化金属被膜抵抗	
R1115	HV755100	R. CAR. FP	100Ω 1/4W		不燃化カーボン抵抗	01
⚠ R1116	V8072100	R. MTL. OXD	5.6KΩ 1W		酸化金属被膜抵抗	
R1117	HV755560	R. CAR. FP	560Ω 1/4W		不燃化カーボン抵抗	01
⚠ R1119-1130	HV755100	R. CAR. FP	100Ω 1/4W		不燃化カーボン抵抗	01
R1131	HV756470	R. CAR. FP	4.7KΩ 1/4W		不燃化カーボン抵抗	01
R1132	V8072000	R. MTL. OXD	4.7KΩ 1W		酸化金属被膜抵抗	
⚠ R1133-1144	HV753470	R. CAR. FP	4.7Ω 1/4W		不燃化カーボン抵抗	01
R1145	HV754100	R. CAR. FP	10Ω 1/4W		不燃化カーボン抵抗	01
R1147-1148	HV754100	R. CAR. FP	10Ω 1/4W		不燃化カーボン抵抗	01
⚠ R1149-1150	V3873200	R. CEMENT	0.22Ω 3W		セメント抵抗	02
* ⚠ R1151-1153	WG471300	R. WW	0.22Ω+0.22Ω		セメント抵抗	
⚠ R1154	V3873200	R. CEMENT	0.22Ω 3W		セメント抵抗	02
⚠ R1173-1178	V8070300	R. MTL. FLM	10Ω 1W		金属被膜抵抗	
R1202-1203	V8070200	R. MTL. FLM	4.7Ω 1W		金属被膜抵抗	
⚠ R1214	HV755100	R. CAR. FP	100Ω 1/4W		不燃化カーボン抵抗	01
R1215	HV756100	R. CAR. FP	1KΩ 1/4W		不燃化カーボン抵抗	01
R1222	HV755180	R. CAR. FP	180Ω 1/4W		不燃化カーボン抵抗	01
R1230	HV755180	R. CAR. FP	180Ω 1/4W		不燃化カーボン抵抗	01
R1232	HV753470	R. CAR. FP	4.7Ω 1/4W		不燃化カーボン抵抗	01
R1237	HV755180	R. CAR. FP	180Ω 1/4W		不燃化カーボン抵抗	01
R1238	HV753470	R. CAR. FP	4.7Ω 1/4W		不燃化カーボン抵抗	01
R1240	HV755180	R. CAR. FP	180Ω 1/4W		不燃化カーボン抵抗	01
⚠ R1243-1244	HV753100	R. CAR. FP	1Ω 1/4W		不燃化カーボン抵抗	01
R1245	HV753470	R. CAR. FP	4.7Ω 1/4W		不燃化カーボン抵抗	01
R1246	HV755180	R. CAR. FP	180Ω 1/4W		不燃化カーボン抵抗	01
R1249	HV753470	R. CAR. FP	4.7Ω 1/4W		不燃化カーボン抵抗	01
R1252	HV753470	R. CAR. FP	4.7Ω 1/4W		不燃化カーボン抵抗	01
R1253	HV755180	R. CAR. FP	180Ω 1/4W		不燃化カーボン抵抗	01
R1254	HV753470	R. CAR. FP	4.7Ω 1/4W		不燃化カーボン抵抗	01
RY100-102	WA544800	RELAY	DC G5PA-28		リレー 24V	04
RY103	V5178900	RELAY	DC DQ24D1-OS(M)		リレー 24V	
RY104	WA544800	RELAY	DC G5PA-28		リレー 24V	04
RY105	WE648700	RELAY	DC DH24D2-0-0		リレー 24V	06
ST100	V4040500	SCR. TERM	M3		スクリュー/ターミナル	01
TE100	WC631900	TERM. SP	LTS0810-1017FM	JUCRTA	スピーカーターミナル	06
* TE100	WD477500	TERM. SP	LTS0810-1015FM	KGEL	スピーカーターミナル	
TE101	WC631900	TERM. SP	LTS0810-1017FM	JUCRTA	スピーカーターミナル	06
* TE101	WD477500	TERM. SP	LTS0810-1015FM	KGEL	スピーカーターミナル	
	WE774200	SCR. BND. HD	3x10 MFZN2W3		バインドBタイトネジ	01

* New Parts * 新規部品

RX-V559/HTR-5950/
DSP-AX559

RX-V559/DSP-AX559

HTR-5950

P.C.B. VIDEO

Ref. No.	Part No.	Description	Remarks	Markets	部 品 名	Rank
	WG769500	P.C.B.	VIDEO		P C B V I D E O	
	WG769600	P.C.B.	VIDEO		P C B V I D E O	
CB401	VB389900	CN.BS.PIN	3P		ベースピン	01
CB402	VN520900	CN.BS.PIN	52045 26P TE		FFCコネクタ	02
C4001-4002	UR837470	C.EL	47uF 16V		ケミコン	01
C4003	UR837100	C.EL	10uF 16V		ケミコン	01
C4004-4005	UR818100	C.EL	100uF 6.3V		ケミコン	01
C4006	UR837100	C.EL	10uF 16V		ケミコン	01
C4007-4010	UR837470	C.EL	47uF 16V		ケミコン	01
C4011	UR837100	C.EL	10uF 16V		ケミコン	01
C4012	UR837470	C.EL	47uF 16V		ケミコン	01
C4013	UR818100	C.EL	100uF 6.3V		ケミコン	01
C4014	UR818470	C.EL	470uF 6.3V		ケミコン	01
C4015	UR866100	C.EL	1uF 50V		ケミコン	01
C4016	UR837100	C.EL	10uF 16V		ケミコン	01
C4017	UR818100	C.EL	100uF 6.3V		ケミコン	01
C4021	UR866470	C.EL	4.7uF 50V		ケミコン	01
C4023	UR818100	C.EL	100uF 6.3V		ケミコン	01
C4024	UR818330	C.EL	330uF 6.3V		ケミコン	01
C4025	UR818100	C.EL	100uF 6.3V		ケミコン	01
C4027-4029	UR818100	C.EL	100uF 6.3V		ケミコン	01
C4031-4033	UR818100	C.EL	100uF 6.3V		ケミコン	01
C4101-4102	US062100	C.CE.CHP	100pF 50V B		チップセラコン	01
C4103	US135100	C.CE.CHP	0.1uF 16V		チップセラコン	01
C4104-4107	US062100	C.CE.CHP	100pF 50V B		チップセラコン	01
C4108-4126	US135100	C.CE.CHP	0.1uF 16V		チップセラコン	01
C4127	US064100	C.CE.CHP	0.01uF 50V B		チップセラコン	01
C4128	US062120	C.CE.CHP	120pF 50V B		チップセラコン	01
C4129	US062220	C.CE.CHP	220pF 50V B		チップセラコン	01
C4130-4135	US135100	C.CE.CHP	0.1uF 16V		チップセラコン	01
C4136	US060500	C.CE.CHP	5pF 50V B	JUCRK	チップセラコン	01
C4136	US060300	C.CE.CHP	3pF 50V B	TAGEL	チップセラコン	01
C4137	US060800	C.CE.CHP	8pF 50V B	JUCRK	チップセラコン	01
C4137	US060300	C.CE.CHP	3pF 50V B	TAGEL	チップセラコン	01
C4138	US135100	C.CE.CHP	0.1uF 16V		チップセラコン	01
C4139	US060800	C.CE.CHP	8pF 50V B	JUCRK	チップセラコン	01
C4139	US060300	C.CE.CHP	3pF 50V B	TAGEL	チップセラコン	01
C4140	US062470	C.CE.CHP	470pF 50V B		チップセラコン	01
C4141	US061240	C.CE.CHP	24pF 50V B		チップセラコン	01
C4142	US135100	C.CE.CHP	0.1uF 16V		チップセラコン	01
C4143	US061240	C.CE.CHP	24pF 50V B		チップセラコン	01
C4144	US063120	C.CE.CHP	1200pF 50V B		チップセラコン	01
C4145	US135100	C.CE.CHP	0.1uF 16V		チップセラコン	01
C4149-4150	US135100	C.CE.CHP	0.1uF 16V		チップセラコン	01
C4157-4163	US135100	C.CE.CHP	0.1uF 16V		チップセラコン	01
C4164	WG251600	C.CE.CHP	4.7uF 6.3V		チップセラ	01
C4165	US064100	C.CE.CHP	0.01uF 50V B		チップセラコン	01
C4166-4168	US135100	C.CE.CHP	0.1uF 16V		チップセラコン	01
C4169-4172	US064100	C.CE.CHP	0.01uF 50V B		チップセラコン	01
C4173	US135100	C.CE.CHP	0.1uF 16V		チップセラコン	01
C4174	US064100	C.CE.CHP	0.01uF 50V B		チップセラコン	01
C4175	US135100	C.CE.CHP	0.1uF 16V		チップセラコン	01
C4176	US034820	C.CE.CHP	0.082uF 16V K		チップセラコン	01
C4177	US064100	C.CE.CHP	0.01uF 50V B		チップセラコン	01
C4178-4179	US135100	C.CE.CHP	0.1uF 16V		チップセラコン	01
C4180-4181	US064100	C.CE.CHP	0.01uF 50V B		チップセラコン	01
C4182	WG251600	C.CE.CHP	4.7uF 6.3V		チップセラ	01
C4183	US064100	C.CE.CHP	0.01uF 50V B		チップセラコン	01
C4184-4185	US060900	C.CE.CHP	9pF 50V B		チップセラコン	01
C4186-4190	US064100	C.CE.CHP	0.01uF 50V B		チップセラコン	01

* New Parts * 新規部品

P.C.B. VIDEO

Ref. No.	Part No.	Description	Remarks	Markets	部 品 名	Rank
C4193-4194	UR818100	C. EL	100uF 6.3V		ケミコン	01
C4195-4197	US135100	C. CE. CHP	0.1uF 16V		チップセラコン	01
C4198-4200	UR837100	C. EL	10uF 16V		ケミコン	01
C4201-4202	US062100	C. CE. CHP	100pF 50V B		チップセラコン	01
C4203-4205	US135100	C. CE. CHP	0.1uF 16V		チップセラコン	01
D4001-4007	VT332900	DIODE	1SS355		ダイオード	01
D4009	VT332900	DIODE	1SS355		ダイオード	01
D4011	VT332900	DIODE	1SS355		ダイオード	01
IC401	X6742A00	IC	LA73050-TLM-E		アンプIC	04
IC402-404	XY549A00	IC	TC74HC4051AFEL		ロジックIC	
IC405	XY879A00	IC	TC74HC4053AF(EL)		ロジックIC	
IC406	XZ509A00	IC	TC74VHC04FT INVER		ロジックIC	01
IC407	XY879A00	IC	TC74HC4053AF(EL)		ロジックIC	
IC408	X5597A00	IC	LC74781JM-9798		IC アナログ	07
IC409	X6869A00	IC	NJM2885DL1-33		電源IC	03
IC410	X6868A00	IC	NJM2885DL1-18		電源IC	03
IC411	X7325A00	IC	ADV7180BSTZ		IC	
IC412	X6671A00	IC	ADV7172KSTZ		IC	
IC413	X6741A00	IC	LA7106M-TLM-E		アンプIC	
JK401-402	V9273500	CN. DIN	2P YKF51-5605		D I Nコネクタ	
JK403	VS867300	CN. DIN	4P YKF51-5501		D I Nコネクタ	03
PJ401	V7189800	JACK. PIN	1P		ピンジャック	01
PJ402-403	V7190000	JACK. PIN	2P		ピンジャック	
PN401-402	V9637500	PIN	L=70 #18		スタイルピン	
Q4001	VV556400	TR	2SC2412K Q, R, S		トランジスタ	01
Q4002	WF550000	TR	2SC3837K T146 N, P		トランジスタ	01
Q4003	VV556500	TR	2SA1037K Q, R, S		トランジスタ	01
Q4004	VV556400	TR	2SC2412K Q, R, S		トランジスタ	01
Q4005	WF549900	TR	2SC3906K T146 R, S		トランジスタ	01
Q4006	VV556400	TR	2SC2412K Q, R, S		トランジスタ	01
Q4010-4013	WG261200	FET	2SK2158-T2B-A		F E T	01
R4022	HV753100	R. CAR. FP	1Ω 1/4W		不燃化カーボン抵抗	01
R4035	HV753220	R. CAR. FP	2.2Ω 1/4W		不燃化カーボン抵抗	01
R4038	HV753100	R. CAR. FP	1Ω 1/4W		不燃化カーボン抵抗	01
R4040	HV757100	R. CAR. FP	10KΩ 1/4W		不燃化カーボン抵抗	01
R4041	HV753220	R. CAR. FP	2.2Ω 1/4W		不燃化カーボン抵抗	01
R4046	HV753100	R. CAR. FP	1Ω 1/4W		不燃化カーボン抵抗	01
R4048	HV755470	R. CAR. FP	470Ω 1/4W		不燃化カーボン抵抗	01
R4052-4053	HV755470	R. CAR. FP	470Ω 1/4W		不燃化カーボン抵抗	01
R4067	HV755470	R. CAR. FP	470Ω 1/4W		不燃化カーボン抵抗	01
R4072	V8070000	R. MTL. FLM	1Ω 1W		金属被膜抵抗	01
R4078	V8070000	R. MTL. FLM	1Ω 1W		金属被膜抵抗	01
XL401	WD280800	RSNR. CRY	14.31818M SMD-49	JUCRK	水晶振動子	
XL401	WD280900	RSNR. CRY	17.734475M SMD-49	TAGEL	水晶振動子	
XL402	VZ772700	RSNR. CRY	28.63636MHz		水晶振動子	03

* New Parts * 新規部品

RX-V559/HTR-5950/
DSP-AX559

HTR-5950

RX-V559/DSP-AX559

Chip Resistors

● The chip resistor is not supplied as a replacement part.
 * When a chip resistor is necessary, use the following part.
 AAX60720: CHIP RESISTOR SAMPLE BOOK

● チップ抵抗はリピーズ部品として供給しません。
 * チップ抵抗が必要の場合は、下記の部品表をご利用ください。
 AAX60720: CHIP RESISTOR SAMPLE BOOK

Ref. No.	Part No.	Description	Remarks	Markets	部 品 名	Rank
	R_CHP	0Ω			チップ抵抗	
	R_CHP	2.2Ω	1/16W J		チップ抵抗	
	R_CHP	10Ω	1/16W J		チップ抵抗	
	R_CHP	75Ω	1/16W J		チップ抵抗	
	R_CHP	100Ω	1/16W J		チップ抵抗	
	R_CHP	220Ω	1/16W J		チップ抵抗	
	R_CHP	270Ω	1/16W J		チップ抵抗	
	R_CHP	330Ω	1/16W J		チップ抵抗	
	R_CHP	470Ω	1/16W J		チップ抵抗	
	R_CHP	1kΩ	1/16W J		チップ抵抗	
	R_CHP	3.3kΩ	1/16W J		チップ抵抗	
	R_CHP	4.7kΩ	1/16W J		チップ抵抗	
	R_CHP	10kΩ	1/16W J		チップ抵抗	
	R_CHP	15kΩ	1/16W J		チップ抵抗	
	R_CHP	22kΩ	1/16W J		チップ抵抗	
	R_CHP	33kΩ	1/16W J		チップ抵抗	
	R_CHP	47kΩ	1/16W J		チップ抵抗	
	R_CHP	100kΩ	1/16W J		チップ抵抗	
	R_CHP	470kΩ	1/16W J		チップ抵抗	
	R_CHP	680kΩ	1/16W J		チップ抵抗	
	R_CHP	820Ω	1/16W D		チップ金属被膜抵抗	
	R_MTL_CHP	4.7kΩ	1/16W D		チップ金属被膜抵抗	
	R_MTL_CHP	5.6kΩ	1/16W D		チップ金属被膜抵抗	
	R_MTL_CHP	47kΩ	1/16W D		チップ金属被膜抵抗	

Carbon Resistors

Value	1/4W Type Part No.	1/6W Type Part No.	Value	1/4W Type Part No.	1/6W Type Part No.
1.0 Ω	HJ35 3100	HF85 3100	10 kΩ	HF45 7100	HF45 7100
1.8 Ω	HJ35 3180	*	11 kΩ	HF45 7110	HF45 7110
2.2 Ω	HJ35 3220	HF85 3220	12 kΩ	HJ35 7120	HF85 7120
3.3 Ω	HJ35 3330	HF85 3330	13 kΩ	HF45 7130	HF45 7130
4.7 Ω	HJ35 3470	HF85 3470	15 kΩ	HF45 7150	HF45 7150
5.6 Ω	HJ35 3560	HF85 3560	18 kΩ	HF45 7180	HF45 7180
10 Ω	HJ35 4100	HF45 4100	22 kΩ	HF45 7220	HF45 7220
15 Ω	HJ35 4150	HF85 4150	24 kΩ	HF45 7240	HF45 7240
22 Ω	HF45 4220	HF45 4220	27 kΩ	HJ35 7270	HF85 7270
27 Ω	HJ35 4270	HF85 4270	30 kΩ	HF45 7300	HF45 7300
33 Ω	HF45 4330	HF45 4330	33 kΩ	HF45 7330	HF45 7330
39 Ω	HJ35 4470	HF85 4390	36 kΩ	HF45 7360	HF45 7360
47 Ω	HF45 4470	HF45 4470	39 kΩ	HF45 7390	HF45 7390
56 Ω	HF45 4560	HF45 4560	47 kΩ	HF45 7470	HF45 7470
68 Ω	HF45 4680	HF45 4680	51 kΩ	HF45 7510	HF45 7510
75 Ω	HF45 4750	HF45 4750	56 kΩ	HF45 7560	HF45 7560
82 Ω	HF45 4820	HF45 4820	62 kΩ	HF45 7620	HF45 7620
91 Ω	HF45 4910	HF45 4910	68 kΩ	HF45 7680	HF45 7680
100 Ω	HF45 5100	HF45 5100	82 kΩ	HF45 7820	HF45 7820
110 Ω	HJ35 5110	HF85 5110	91 kΩ	HF45 7910	HF45 7910
120 Ω	HF45 5120	HF45 5120	100 kΩ	HF45 8100	HF45 8100
150 Ω	HF45 5150	HF45 5150	110 kΩ	HF45 8110	HF45 8110
160 Ω	HJ35 5160	*	120 kΩ	HF45 8120	HF45 8120
180 Ω	HF45 5180	HF45 5180	150 kΩ	HF45 8150	HF45 8150
200 Ω	HF45 5200	HF45 5200	180 kΩ	HF45 8180	HF45 8180
220 Ω	HF45 5220	HF45 5220	220 kΩ	HJ35 8220	HF85 8220
270 Ω	HF45 5270	HF45 5270	270 kΩ	HF45 8270	HF45 8270
300 Ω	HF45 5300	HF45 5300	300 kΩ	HF45 8300	HF45 8300
390 Ω	HF45 5390	HF45 5390	330 kΩ	HF45 8330	HF45 8330
430 Ω	HF45 5430	HF45 5430	390 kΩ	HJ35 8390	HF85 8390
470 Ω	HF45 5470	HF45 5470	470 kΩ	HF45 8470	HF45 8470
510 Ω	HF45 5510	HF45 5510	560 kΩ	HJ35 8560	HF85 8560
560 Ω	HF45 5560	HF45 5560	680 kΩ	HJ35 8680	HF85 8680
680 Ω	HF45 5680	HF45 5680	820 kΩ	HJ35 8820	HF85 8820
820 Ω	HF45 5820	HF45 5820	1.0 MΩ	HF45 9100	HF45 9100
910 Ω	HF45 5910	HF45 5910	1.2 MΩ	HJ35 9120	*
1.0 kΩ	HF45 6100	HF45 6100	1.5 MΩ	HJ35 9150	HF85 9150
1.2 kΩ	HF45 6120	HF45 6120	1.8 MΩ	HJ35 9180	HF85 9180
1.5 kΩ	HF45 6150	HF45 6150	2.2 MΩ	HJ35 9220	HF85 9220
1.8 kΩ	HF45 6180	HF45 6180	3.3 MΩ	HJ35 9330	HF85 9330
2.0 kΩ	HJ35 6200	HF85 6200	3.9 MΩ	HJ35 9390	*
2.2 kΩ	HF45 6220	HF45 6220	4.7 MΩ	HJ35 9470	HF85 9470
2.4 kΩ	HJ35 6240	HF85 6240			
2.7 kΩ	HF45 6270	HF45 6270			
3.0 kΩ	HF45 6300	HF45 6300			
3.3 kΩ	HF45 6330	HF45 6330			
3.6 kΩ	HJ35 6360	HF85 6360			
3.9 kΩ	HF45 6390	HF45 6390			
4.7 kΩ	HF45 6470	HF45 6470			
5.1 kΩ	HF45 6510	HF45 6510			
5.6 kΩ	HF45 6560	HF45 6560			
6.8 kΩ	HF45 6680	HF45 6680			
8.2 kΩ	HF45 6820	HF45 6820			
9.1 kΩ	HF45 6910	HF45 6910			

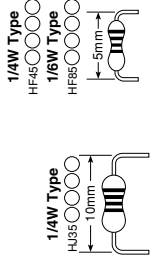

* : Not available

*: New Parts * 新部品

1 • OVERALL ASSY RX-V559/DSP-AX559

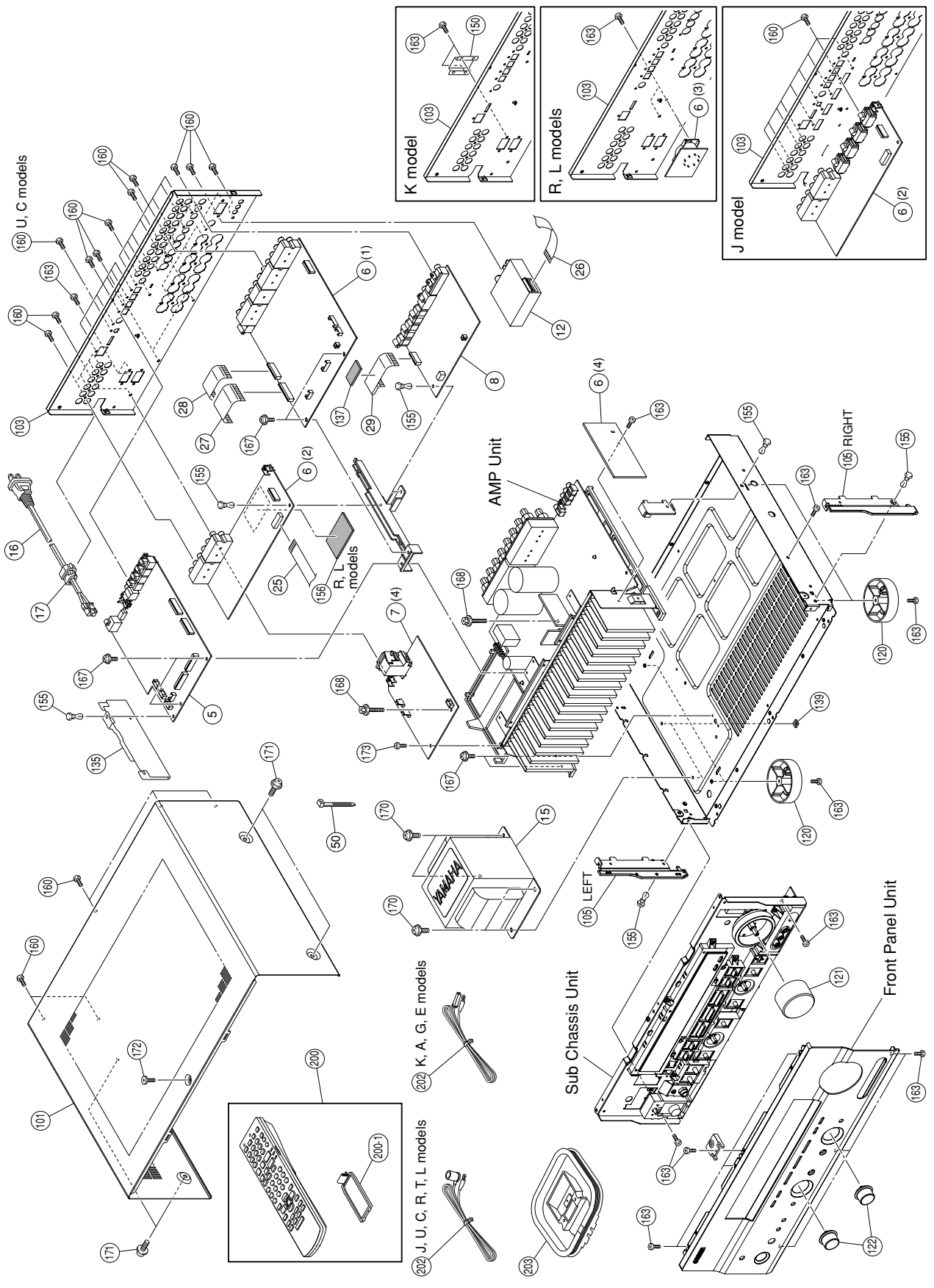

● OVERALL ASS'Y RX-V559/DSP-AX559

Ref. No.	Part No.	Description	Remarks	Markets	部 品 名	Rank
5	W6681000	P.C.B. ASS'Y		J	P.C.B. DSP	
5	W6681100	P.C.B. ASS'Y		UC	P.C.B. DSP	
5	W6681200	P.C.B. ASS'Y		R	P.C.B. DSP	
5	W6681300	P.C.B. ASS'Y		T	P.C.B. DSP	
5	W6681400	P.C.B. ASS'Y		K	P.C.B. DSP	
5	W6681500	P.C.B. ASS'Y		A	P.C.B. DSP	
5	W6681700	P.C.B. ASS'Y		GE	P.C.B. DSP	
5	W6681800	P.C.B. ASS'Y		L	P.C.B. DSP	
5	W6686000	P.C.B. ASS'Y	FUNCTION	UCTKA	P.C.B. ファンクション	
6	W6686100	P.C.B. ASS'Y	FUNCTION	R	P.C.B. ファンクション	
6	W6686200	P.C.B. ASS'Y	FUNCTION	R	P.C.B. ファンクション	
6	W6686400	P.C.B. ASS'Y	FUNCTION	GE	P.C.B. ファンクション	
6	W6686500	P.C.B. ASS'Y	FUNCTION	L	P.C.B. ファンクション	
7	W6769900	P.C.B. ASS'Y	OPERATION	J	P.C.B. オペレーション	
7	W6770000	P.C.B. ASS'Y	OPERATION	UC	P.C.B. オペレーション	
7	W6770200	P.C.B. ASS'Y	OPERATION	TK	P.C.B. オペレーション	
7	W6770300	P.C.B. ASS'Y	OPERATION	A	P.C.B. オペレーション	
7	W6770500	P.C.B. ASS'Y	OPERATION	GE	P.C.B. オペレーション	
7	W6770600	P.C.B. ASS'Y	OPERATION	L	P.C.B. オペレーション	
8	W6769500	P.C.B. ASS'Y	VIDEO	JUCKR	P.C.B. ビデオ	
8	W6769600	P.C.B. ASS'Y	VIDEO	TABEL	P.C.B. ビデオ	
12	V6782200	AM/FM TUNER	TFCEJ117A	J	AM/FMチューナー	
12	V6782300	AM/FM TUNER	TFCEJ115A	J	AM/FMチューナー	
12	V6782400	AM/FM TUNER	TFCEJ137A	KAGE	AM/FMチューナー	
15	X7499A00	POWER TRANSFORMER		J	電源トランス	
15	X7500A00	POWER TRANSFORMER		UC	電源トランス	
15	X7501A00	POWER TRANSFORMER		RL	電源トランス	
15	X7502A00	POWER TRANSFORMER		TK	電源トランス	
15	X7503A00	POWER TRANSFORMER		A	電源トランス	
15	X7504A00	POWER TRANSFORMER		GE	電源トランス	
16	W723000	POWER CABLE	2m	J	電源コード	
16	V2727500	POWER CABLE	2m	UC	電源コード	
16	W6992700	POWER CABLE	2m	R	電源コード	
16	W8120600	POWER CABLE	2m	T	電源コード	
16	W753000	POWER CABLE	2m	K	電源コード	
16	W743700	POWER CABLE	2m	A	電源コード	
16	W863600	POWER CABLE	2m	GE	電源コード	
17	V2438700	CORD STOPPER	1UP1		コードストッパー	
25	MF125200	FLEXIBLE FLAT CABLE	2.9P 200mm P=1.25		カード電線 C&C	
26	MF115140	FLEXIBLE FLAT CABLE	1.9P 140mm P=1.25		カード電線 C&C	
27	MF129070	FLEXIBLE FLAT CABLE	2.9P 70mm P=1.25		カード電線 C&C	
28	MF126100	FLEXIBLE FLAT CABLE	2.9P 70mm P=1.25		カード電線 C&C	
29	MF126100	FLEXIBLE FLAT CABLE	2.9P 100mm P=1.25		カード電線 C&C	
50	VU590000	BINDING TIE			インシロックタイ	
101	W6364700	TOP COVER			トップカバー	
101	W6364600	TOP COVER		GD	トップカバー	
101	W6364800	TOP COVER		BL	トップカバー	
103	W6367600	REAR PANEL		TI	リアパネル	
103	W6366600	REAR PANEL		J	リアパネル	
103	W6366900	REAR PANEL		UC	リアパネル	
103	W6367000	REAR PANEL		R	リアパネル	
103	W6367100	REAR PANEL		T	リアパネル	
103	W6367200	REAR PANEL		K	リアパネル	
103	W6367400	REAR PANEL		A	リアパネル	
103	W6367500	REAR PANEL		GE	リアパネル	
105	W6975100	PLATE SIDE			プレートサイド	
105	W6975000	PLATE SIDE			プレートサイド	
105	W6975200	PLATE SIDE			プレートサイド	

* New Parts * 新規部品

Ref. No.	Part No.	Description	Remarks	Markets	部 品 名	Rank
120	V0042500	LEG			レッグ	
120	VS025000	LEG		GD	レッグ	
121	W6375500	VOLUME		BL, TI	ノブ D50	
121	W6375400	VOLUME		GD	ノブ D50	
121	W6375600	VOLUME		BL	ノブ D50	
122	W6375800	PROGRAM, INPUT		TI	ノブ D21.5	
122	W6375700	PROGRAM, INPUT		GD	ノブ D21.5	
122	W6375900	PROGRAM, INPUT		BL	ノブ D21.5	
122	W6376000	PROGRAM, INPUT		TI	ノブ D21.5	
135	W6918400	BARRIER FFC			バリヤー/FFC	
137	W6742300	DAMPER	3/30/60		ダンパー	
139	W6379000	DAMPER			ダンパー	
150	W8466300	COVER AC OUTLETS		K	カバー/ACアウトレット	
155	V0368600	PUSH RIVET	P3555-B		プッシュリベット	
156	W1137300	DAMPER	1/35/55	RL	ダンパー 1/35/55	
160	W2774100	BIND HEAD B-TIGHT SCREW	MFZM23		ボンドヘッドBタイトネジ	
163	W2774300	BIND HEAD B-TIGHT SCREW	MFZM23		ボンドヘッドBタイトネジ	
167	W6002600	PW HEAD B-TIGHT SCREW	MFZM23		PWヘッドBタイトネジ	
168	W6010900	SCREW TC	3x8		スクルー TC	
170	W2774700	BIND HEAD S-TIGHT SCREW	3x20		ボンドヘッドSタイトネジ	
171	V0069600	PW HEAD S-TIGHT SCREW	4x8-10	GD, TI	PWヘッドSタイトネジ	
171	W8132000	PW HEAD S-TIGHT SCREW	4x8-10	BL	PWヘッドSタイトネジ	
172	W2004000	DISH HEAD B-TIGHT SCREW	3x6	GD, TI	DISH Bタイトネジ	
172	W2005000	DISH HEAD B-TIGHT SCREW	3x6	BL	DISH Bタイトネジ	
173	W2774800	BIND HEAD P-TIGHT SCREW	3x8		ボンドヘッドPタイトネジ	
200	W6646400	ACCESSORIES	RAV323	JRTKABEL	付属品	
200	W6646600	REMOTE CONTROL	RAV322	UC	リモコン	
200-1	AAK76600	BATTERY COVER			電池蓋	
202	W6267000	INDOOR FM ANTENNA	1.4m 1pc	JUCRTL	FM簡易アンテナ	
202	V0147100	INDOOR FM ANTENNA	1.4m 1pc	KAGE	FM簡易アンテナ	
203	VR2465000	AM LOOP ANTENNA	1.0m 1pc		AMループアンテナ	
203		BATTERY	SUM-3N 2pcs		乾電池 2PCS	

* New Parts * 新規部品

1 FRONT PANEL UNIT & SUB CHASSIS UNIT RX-V559/DSP-AX559

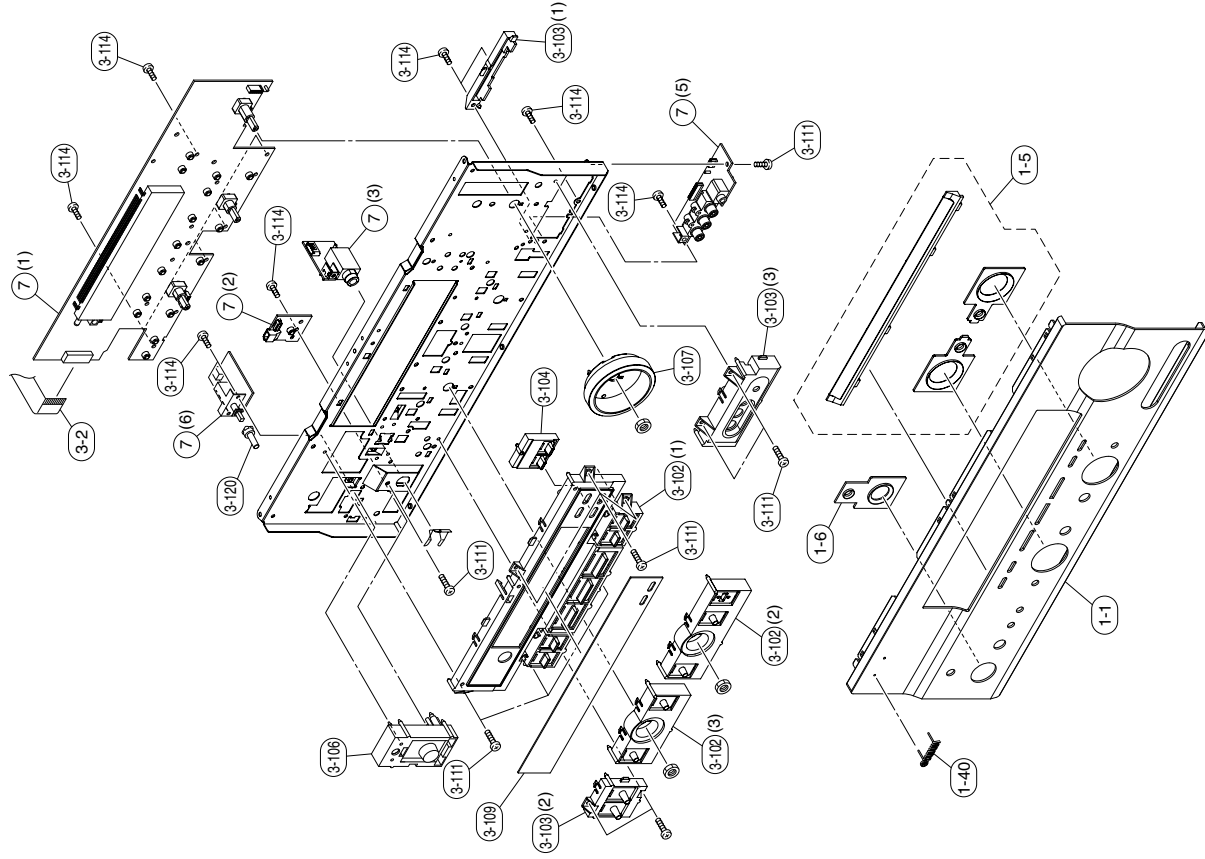

• FRONT PANEL UNIT & SUB CHASSIS UNIT RX-V559/DSP-AX559

Ref. No.	Part No.	Description	Remarks	Markets	部 品 名	Rank
1-1	WG371700	FRONT PANEL	AX559GD	J	フロントパネル	03
1-1	WG371600	FRONT PANEL	V559CD	RTK	フロントパネル	03
1-1	WG371100	FRONT PANEL	V559BL	UC	フロントパネル	
1-1	WG372100	FRONT PANEL	V559BL	PAGE	フロントパネル	
1-1	WG372200	FRONT PANEL	V559TI	C	フロントパネル	
1-1	WG372200	FRONT PANEL	V559TI	RGEL	フロントパネル	
1-5	WG478300	ESCUTCHEON 657	GD		エスカッション657	
1-5	WG478200	ESCUTCHEON 657	BL		エスカッション657	
1-5	WG478400	ESCUTCHEON 657	TI		エスカッション657	
1-6	WG374600	ESCUTCHEON 659	GD		エスカッション659	
1-6	WG374500	ESCUTCHEON 659	BL		エスカッション659	
1-6	WG374700	ESCUTCHEON 659	TI		エスカッション659	
1-40	V6034200	EMBLEM	GD		エンブレム	
1-40	V6034100	EMBLEM	BL, TI		エンブレム	
3-2	MFT23350	FLEXIBLE FLAT CABLE	23P 350mm P=1.25		カード電線 C&C	
3-102	WG490900	BUTTONCASE 650	GD		ボタンケース650	
3-102	WG490800	BUTTONCASE 650	BL		ボタンケース650	
3-102	WG491000	BUTTONCASE 650	TI		ボタンケース650	
3-103	WG374800	ESCUTCHEON PJ	GD		エスカッション PJ	
3-103	WG374800	ESCUTCHEON PJ	BL		エスカッション PJ	
3-103	WG375000	ESCUTCHEON PJ	TI		エスカッション PJ	
3-104	WE182400	BUTTON ZONE2	GD		ボタン/ZONE 2	
3-106	WG374300	BUTTON MAIN	BL		ボタン/メイン	
3-106	WG374200	BUTTON MAIN	TI		ボタン/メイン	
3-106	WG374400	BUTTON MAIN	TI		ボタン/メイン	
3-107	WG375200	ESCUTCHEON VOL	GD		エスカッションVOL	
3-107	WG375100	ESCUTCHEON VOL	BL		エスカッションVOL	
3-107	WG375300	ESCUTCHEON VOL	TI		エスカッションVOL	
3-109	WG542600	SHEET WINDOW	SI		シート/ウインドウ	
3-109	WG542500	SHEET WINDOW	JRTKAGEL		シート/ウインドウ	
3-111	WE774300	BLIND HEAD B-TIGHT SCREW	3x8		ハインドヘッドネジ	01
3-114	WE774800	BLIND HEAD P-TIGHT SCREW	3x8		ハインドヘッドネジ	01
3-120	V6876200	BUTTON D5	GD		ボタン/D5	
3-120	V6876100	BUTTON D5	BL		ボタン/D5	
3-120	V6540300	BUTTON D5	TI		ボタン/D5	
7	WG769900	P.C.B. ASS'Y	OPERATION	J	オブレーション	
7	WG770000	P.C.B. ASS'Y	OPERATION	UC	オブレーション	
7	WG770100	P.C.B. ASS'Y	OPERATION	R	オブレーション	
7	WG770200	P.C.B. ASS'Y	OPERATION	TK	オブレーション	
7	WG770300	P.C.B. ASS'Y	OPERATION	A	オブレーション	
7	WG770500	P.C.B. ASS'Y	OPERATION	GE	オブレーション	
7	WG770600	P.C.B. ASS'Y	OPERATION	L	オブレーション	

* New Parts * 新規部品

1 • AMP UNIT RX-V559/DSP-AX559 HTR-5950

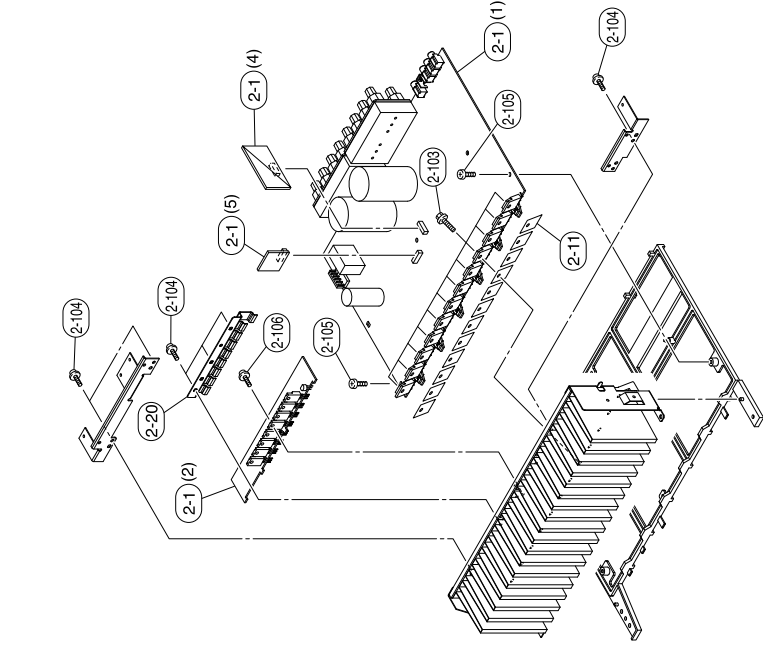

*
*
*
*
*
*
*

Ref. No.	Part No.	Description	Remarks	Markets	部 品 名	Rank
2-1	W6700000	P. C. B. ASS'Y	AX559, V559	JRTA	PCB メイン	
2-1	W6700100	P. C. B. ASS'Y	V559	UC	PCB メイン	
2-1	W6700200	P. C. B. ASS'Y	V559	KGEL	PCB メイン	
2-1	W6701000	P. C. B. ASS'Y	5950	UC	PCB メイン	
2-1	W6701100	P. C. B. ASS'Y	5950	TA	PCB メイン	
2-11	VW849300	RADIATION SHEET			シート/放射	
2-20	W6440600	SUPPORT TH-8			サポート/TR-8	
2-103	VK173200	SCREW TRANSISTOR	3x15 SP MFC2		スクリュー TR	
2-104	WF002600	PM HEAD B-TIGHT SCREW	3x8 MF2N2/3		PWヘッドBタイトネジ	
2-105	WE718000	BIND HEAD P-TIGHT SCREW	3x8 MF2N2/3		バインドPタイトネジ	
2-106	WE714300	BIND HEAD B-TIGHT SCREW	3x8 MF2N2/3		バインドBタイトネジ	

※ New Parts * 新規部品

• OVERALL ASS'Y HTR-5950

Ref. No.	Part No.	Description	Remarks	Markets
* 5	WG682000	P. C. B. ASS'Y	DSP	UC
* 5	WG6956300	P. C. B. ASS'Y	DSP	T
* 5	WG682100	P. C. B. ASS'Y	DSP	A
* 6	WG689100	P. C. B. ASS'Y	FUNCTION OPERATION	UC
* 7	WG671400	P. C. B. ASS'Y	OPERATION	T
* 7	WG6956400	P. C. B. ASS'Y	OPERATION	A
* 7	WG771500	P. C. B. ASS'Y	OPERATION	UC
* 8	WG769500	P. C. B. ASS'Y	VIDEO	TA
* 8	WG769600	P. C. B. ASS'Y	VIDEO	UC
* 12	V6782300	AM/FM TUNER	TFCE1U115A	UCT
* 12	V6782400	AM/FM TUNER	TFCE1E317A	A
* 15	X7500A00	POWER TRANSFORMER		UC
* 15	X7502A00	POWER TRANSFORMER		T
* 15	X7503A00	POWER TRANSFORMER		A
* 16	V2727500	POWER CABLE	2m	UC
* 16	WB120600	POWER CABLE	2m	T
* 16	WC743700	POWER CABLE	2m	A
* 17	V2438700	CORD STOPPER	10P1	A
* 25	MF125200	FLEXIBLE FLAT CABLE	25P 200mm P=1.25	
* 26	MF115140	FLEXIBLE FLAT CABLE	15P 140mm P=1.25	
* 27	MF129070	FLEXIBLE FLAT CABLE	29P 70mm P=1.25	
* 28	MF120070	FLEXIBLE FLAT CABLE	20P 70mm P=1.25	
* 29	MF126100	FLEXIBLE FLAT CABLE	26P 100mm P=1.25	
* 50	VU590000	BINDING TIE	CBTD001B	
* 101	WG437900	TOP COVER		GD
* 101	WG437800	TOP COVER		BL
* 101	WG438100	TOP COVER		SI
* 103	WG438200	REAR PANEL		UC
* 103	WG438300	REAR PANEL		T
* 103	WG438500	REAR PANEL		A
* 103	WG438200	REAR PANEL		
* 120	V0042500	LEG		
* 120	VV544300	LEG	D60XH21	GD
* 120	V5025000	LEG	D60XH21	BL
* 121	WG442700	KNOB D48	VOLUME	SI
* 121	WG442600	KNOB D48	VOLUME	GD
* 121	WG442900	KNOB D48	VOLUME	BL
* 122	WG443300	KNOB D23	VOLUME	SI
* 122	WG443200	KNOB D23	INPUT	GD
* 122	WG443500	KNOB D23	INPUT	BL
* 135	WG918400	BARRIER FFC	INPUT	SI
* 137	V6742300	DAMPER	3/30/60	
* 139	WC879000	DAMPER		
* 155	V0368600	PUSH RIVET	P3555-B	
* 160	WE774100	BIND HEAD BONDING B-T. SCREW	3x8	MFZIN2B3
* 163	WF774300	BIND HEAD B-TIGHT SCREW	3x8	MFZIN2W3
* 167	WF002600	PW HEAD B-TIGHT SCREW	3x8	MFZIN2W3
* 168	WH010900	SCREW IC	3x20	MFZIN2W3
* 170	WE774700	BIND HEAD S-TIGHT SCREW	4x10	MFZIN2W3
* 171	V0069600	PW HEAD S-TIGHT SCREW	4x8-10	MFNI333
* 171	VH313200	PW HEAD S-TIGHT SCREW	4x8-10	MFNI3BL
* 172	WE200400	DISH HEAD B-TIGHT SCREW	3x6	MFNI333
* 172	WE200500	DISH HEAD B-TIGHT SCREW	3x6	MFNI3BL
* 173	WE774800	BIND HEAD P-TIGHT SCREW	3x8	MFZIN2W3

:: New Parts

Ref. No.	Part No.	Description	Remarks	Markets
* 200	WG646300	ACCESSORIES		UC
* 200	WG646400	REMOTE CONTROL	RAV322	TA
* 200-1	AAAX76600	REMOTE CONTROL	RAV323	
* 202	V6267000	BATTERY COVER	1.4m 1pc	UCT
* 202	V0147100	INDOOR FM ANTENNA	1.4m 1pc	A
* 203	VR248500	INDOOR FM ANTENNA	1.0m 1pc	
		AM LOOP ANTENNA	SUM-3N 2pcs	
		BATTERY		

:: New Parts

• FRONT PANEL UNIT HTR-5950

• FRONT PANEL UNIT HTR-5950

Ref. No.	Part No.	Description	Remarks	Markets
1-2	MF123400	FLEXIBLE FLAT CABLE	23P 400mm P=1.25	
1-4	WG517000	FRONT PANEL ASS'Y		UC
1-4	WG516300	FRONT PANEL ASS'Y		A
1-4	WG445500	FRONT PANEL ASS'Y		
1-4	WG445600	FRONT PANEL ASS'Y		
1-5	WG441300	BUTTON CASE		
1-5	WG441100	BUTTON CASE		
1-5	WG441500	BUTTON CASE		
1-13	WG443600	SHEET WINDOW		
1-13	WG443800	SHEET WINDOW		
1-13	WG443700	SHEET WINDOW		
1-13	WG443600	SHEET WINDOW		
1-25	WE774800	BLIND HEAD P-TIGHT SCREW	3x8 MFZM2W3	UC
1-40	V6034200	EMBLEM		A
1-40	V6034100	EMBLEM		
7	WG771400	P.C.B. ASS'Y	OPERATION	UC
7	WG956400	P.C.B. ASS'Y	OPERATION	T
7	WG771500	P.C.B. ASS'Y	OPERATION	A

* * * * *

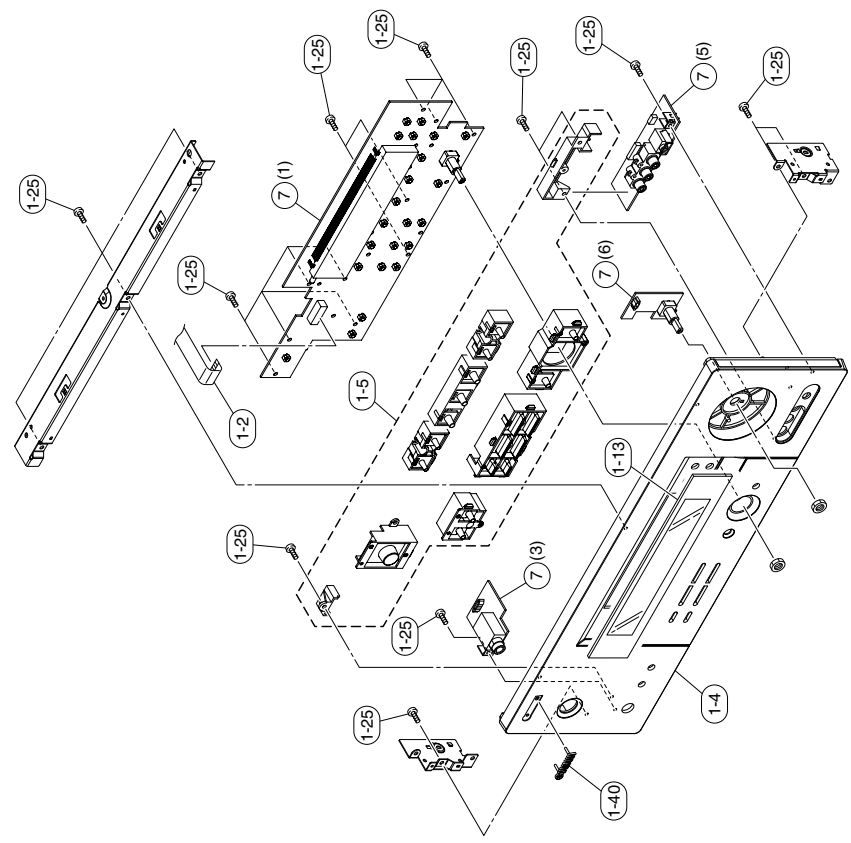

:: New Parts

**1 ■ REMOTE CONTROL RAV322: RX-V559 (U, C models), HTR-5950 (U, C models),
RAV323: RX-V559 (R, T, K, A, G, E, L models), HTR-5950 (T, A models), DSP-AX557 (J model)**

• SCHEMATIC DIAGRAM

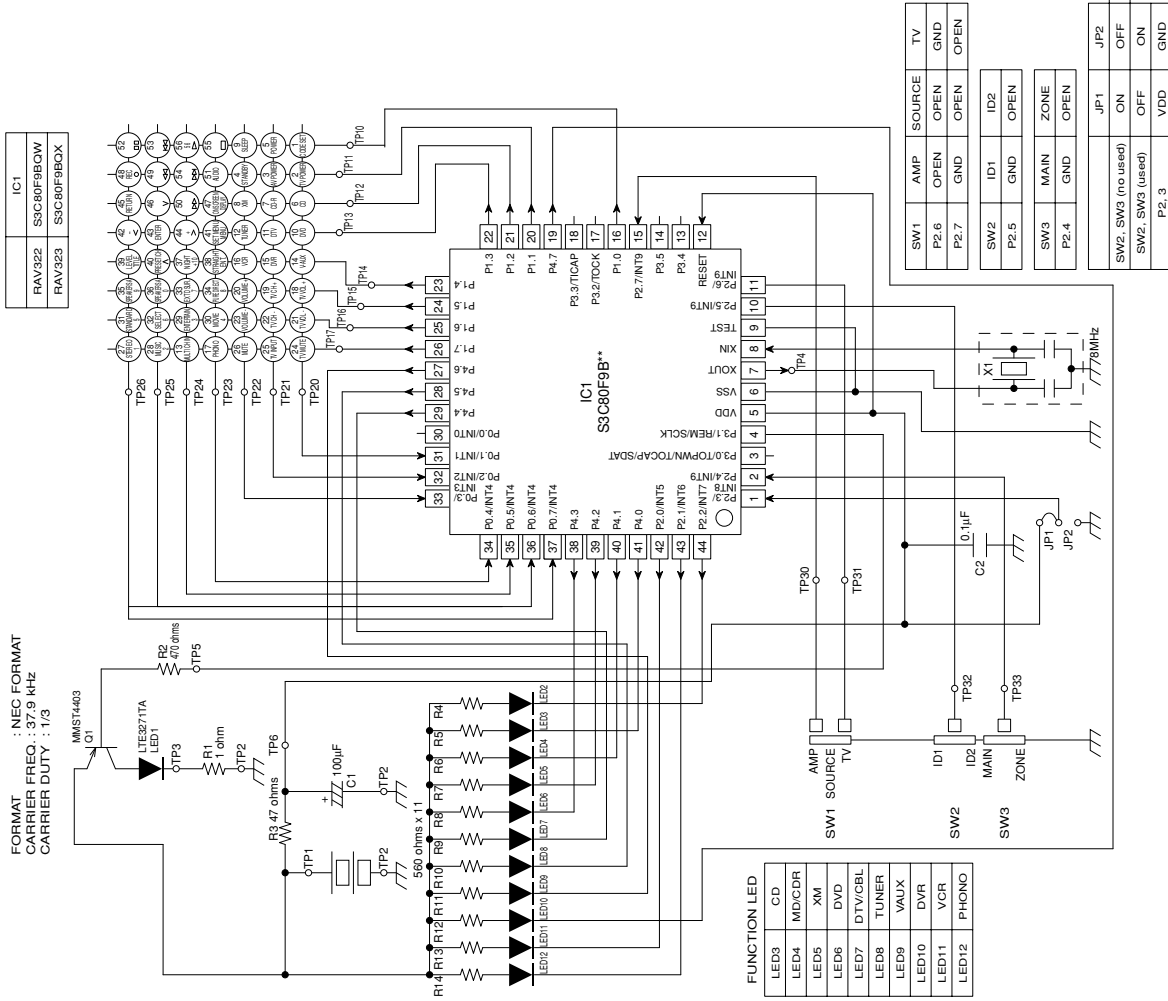

• KEY LAYOUT • KEY CODE

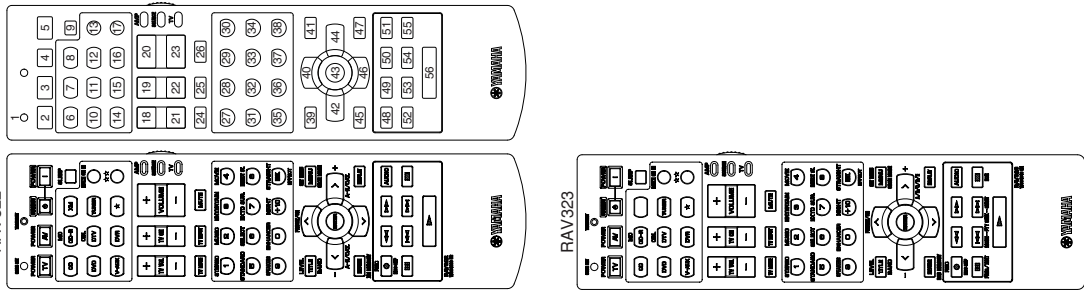

Key No.	Key Label	RCV [00001]	DVD [40839]	DVD-R [51544]	YAMAHA D-TUNER [81916]	D-TUNER [81916]	CD [81907]	UNIVERSAL MID [70888]
1	CODE SET							
2	TV POWER							
3	AV POWER							
4	STANDBY							
5	POWER		004-012	048-012				
6	CD							
7	CD-R (MD)							
8	XM							
9	SLEEP							
10	DVD							
11	DTV (CBL)							
12	TUNER							
13	(MULTI CH IN)							
14	V.AUX							
15	DVR							
16	VCR							
17	(PHONO / S+)							
18	(TV VOL)							
19	(TV CH)							
20	(VOLUME)							
21	(TV VOL)							
22	(TV CH)							
23	(VOLUME)							
24	TV MUTE							
25	TV INPUT							
26	MUTE							
27	1 (STEREO)	7A-1C						
28	2 (MUSIC)	7A-8B	004-001	048-001	7A-E5	7A-E5	7A-61	79-85
29	3 (ENTERTAIN)	7A-89	004-002	048-002	7A-E6	7A-E6	7A-62	79-12
30	4 (MOVIE)	7A-8B	004-003	048-003	7A-E7	7A-E7	7A-63	79-13
31	5 (STANDARD)	7A-8B	004-004	048-004	7A-E8	7A-E8	7A-64	79-14
32	6 (SELECT)	7A-96	004-005	048-005	7A-E9	7A-E9	7A-65	79-15
33	7 (EXTD SUR.)	7A-97	004-006	048-006	7A-EA	7A-EA	7A-66	79-16
34	8 (PURE DIRECT)	7A-DD	004-007	048-007	7A-EB	7A-EB	7A-67	79-8B
35	9 (SPEAKERS)	7A-9A	004-008	048-008	7A-EC	7A-EC	7A-68	79-18
36	0 (ENHANCER)	7A-9A	004-009	048-009	7A-B1	7A-B1	7A-69	79-19
37	+10 (NIGHT)	7A-95	004-000	048-000	7A-B2	7A-B2	7A-60	79-10
38	ENT. (STRAIGHT / EFFECT)	7A-95	004-120	7A-B3	7A-B3	7A-6F	79-9F
39	△ (PRESET / BAND)	7A-96	004-113	048-200	7A-AE	7A-70		
40	▽ (PRESET / CH)	7A-98	004-088	048-088	7A-10	7A-6A		
41	MENU (SET MENU)	7A-9C	004-084	048-084	7A-AB	7A-6D		
42	< (C)	7A-93	004-080	048-080	7A-AC	7A-6E		
43	ENTER	7A-DE	004-092	048-092	7A-AD	7A-6F		
44	> (A/B/C/D/E)	7A-92	004-091	048-091	7A-12	7A-6C		
45	RETURN	7A-9A	004-131	048-131	7A-AF	7A-71		
46	>>	7A-99	004-089	048-089	7A-11	7A-6B		
47	DISPLAY (ON SCREEN)	7A-C2	004-015	048-015	7A-B0	7A-72	79-0A	79-AS
48	REC / DISC (SKIP)		004-127	048-355			7A-4F	7A-4F
49	SKIP		004-041	048-041			7A-0D	7A-AC
50	SKIP		004-040	048-040			7A-0C	7A-AD
51	AUDIO		004-078	048-078				
52	⏮ (FREQUENT)		004-048	048-048				
53	⏪ (MODE-PTY)		004-033	048-033	7A-4A	7A-4A	7A-09	7A-A9
54	⏩ (SEEK-START)		004-032	048-032	7A-A7	7A-A7	7A-0A	7A-AE
55	⏭ (EON)		004-049	048-049	7A-A5	7A-A5	7A-09	7A-AA
56	⏮		004-044	048-044			7A-08	7A-AB

ADVANCED SETUP

This unit has additional menus that are displayed in the front panel display. The advanced settings (indicated in bold under each parameter) to reflect the needs of your listening environment.

Notes

- The settings you make are reflected next time you press MASTER ON/OFF inward to the ON position to turn on this unit.
- Only MASTER ON/OFF, STRAIGHT (EFFECT) and the PROGRAM selector are effective while you are using the advanced setup menu.
- The advanced setup menu is only available in the front panel display.

- 1 Press MASTER ON/OFF on the front panel to turn off this unit.
- 2 Press and hold STRAIGHT (EFFECT) on the front panel and then press MASTER ON/OFF inward to the ON position to turn on this unit. This unit turns on, and the advanced setup menu appears in the front panel display.
- 3 Rotate the PROGRAM selector on the front panel to select the parameter you want to adjust. The name of the selected parameter appears in the front panel display.
- 4 Press STRAIGHT (EFFECT) on the front panel repeatedly to change the selected parameter setting.
- 5 Press MASTER ON/OFF on the front panel to release it outward to the OFF position to save the new setting and turn off this unit.

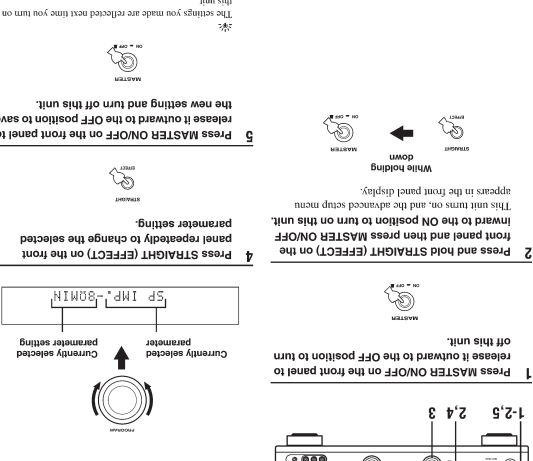

* The settings you make are reflected next time you turn on this unit.

本機の設定を変更する (ADVANCED SETUP)

ADVANCED SETUPにより、本機の設定を初期設定に戻したり、リモコンIDを変更することが出来ます。

● ADVANCED SETUPの操作を始めるにあたり、本機から音が出なくなる場合があります。

- MASTER ON/OFF、STRAIGHT/EFFECTキー、PROGRAMセレクトキー以外を押さないでください。

手順 ADVANCED SETUPの操作

1 MASTER ON/OFFスイッチを押して、本機のを電源をオフにする。

2 STRAIGHT/EFFECTキーを押しながら、もう一度MASTER ON/OFFスイッチを押す。

3 PROGRAMセレクトキーを一回りして設定したメニューを選び、メニュー項目を戻す。

ADVANCED SETUPのメニュー項目

必須に応じて初期設定を変更してください。

2 STRAIGHT/EFFECTキーを押しながら、もう一度MASTER ON/OFFスイッチを押す。

3 PROGRAMセレクトキーを一回りして設定したメニューを選び、メニュー項目を戻す。

1 MASTER ON/OFFスイッチを押して、本機のを電源をオフにする。



ADVANCED SETUP

Use this feature to set the speaker impedance of this unit. Choose: 8ΩMIN, 6ΩMIN, 4ΩMIN, 2ΩMIN. The advanced setup menu offers additional parameters) to reflect the needs of your listening environment.

Notes

- The settings you make are reflected next time you press MASTER ON/OFF inward to the ON position to turn on this unit.
- Only MASTER ON/OFF, STRAIGHT (EFFECT) and the PROGRAM selector are effective while you are using the advanced setup menu.
- The advanced setup menu is only available in the front panel display.

- 1 Press MASTER ON/OFF on the front panel to turn off this unit.
- 2 Press and hold STRAIGHT (EFFECT) on the front panel and then press MASTER ON/OFF inward to the ON position to turn on this unit. This unit turns on, and the advanced setup menu appears in the front panel display.
- 3 Rotate the PROGRAM selector on the front panel to select the parameter you want to adjust. The name of the selected parameter appears in the front panel display.
- 4 Press STRAIGHT (EFFECT) on the front panel repeatedly to change the selected parameter setting.
- 5 Press MASTER ON/OFF on the front panel to release it outward to the OFF position to save the new setting and turn off this unit.

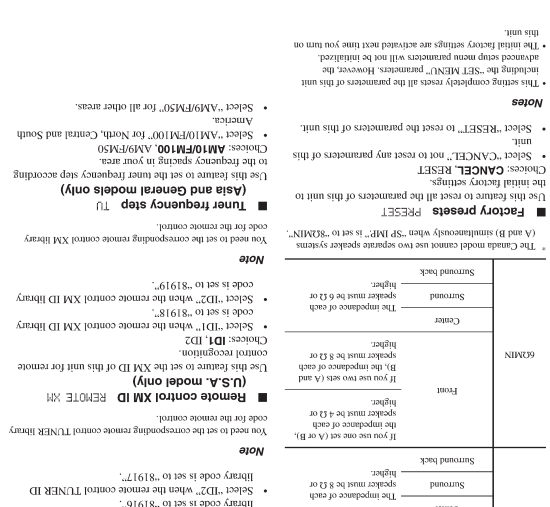

* The settings you make are reflected next time you turn on this unit.

本機の設定を初期設定に戻す

リモコンIDを変更することが出来ます。

● ADVANCED SETUPの操作を始めるにあたり、本機から音が出なくなる場合があります。

- MASTER ON/OFF、STRAIGHT/EFFECTキー、PROGRAMセレクトキー以外を押さないでください。

手順 本機の設定を初期設定に戻す

1 MASTER ON/OFFスイッチを押して、本機のを電源をオフにする。

2 STRAIGHT/EFFECTキーを押しながら、もう一度MASTER ON/OFFスイッチを押す。

3 PROGRAMセレクトキーを一回りして、本機のを電源を戻す。

ADVANCED SETUPのメニュー項目

必須に応じて初期設定を変更してください。

2 STRAIGHT/EFFECTキーを押しながら、もう一度MASTER ON/OFFスイッチを押す。

3 PROGRAMセレクトキーを一回りして設定したメニューを選び、メニュー項目を戻す。

1 MASTER ON/OFFスイッチを押して、本機のを電源をオフにする。

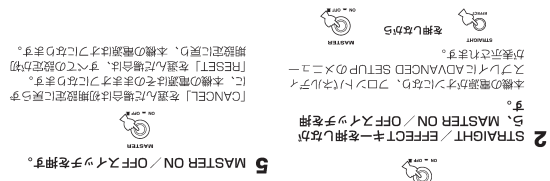

* The settings you make are reflected next time you turn on this unit.

この機能は、本機の設定を初期設定に戻すために使用します。本機の設定を初期設定に戻すには、本機の設定を初期設定に戻す必要があります。本機の設定を初期設定に戻すには、本機の設定を初期設定に戻す必要があります。