

AV RECEIVER RX-V461/HTR-6040/ RX-V461DAB SERVICE MANUAL

For T, B, G and E models

This service manual is the RX-V461/HTR-6040/RX-V461DAB (T, B, G and E models).
For the RX-V461/HTR-6040/DSP-AX461 (U, C, R, K, A, L and J models) service manual, please refer to the following service manual:

RX-V461/HTR-6040/DSP-AX461 (U, C, R, K, A, L and J models): 101041

IMPORTANT NOTICE

This manual has been provided for the use of authorized YAMAHA Retailers and their service personnel. It has been assumed that basic service procedures inherent to the industry, and more specifically YAMAHA Products, are already known and understood by the users, and have therefore not been restated.

WARNING: Failure to follow appropriate service and safety procedures when servicing this product may result in personal injury, destruction of expensive components, and failure of the product to perform as specified. For these reasons, we advise all YAMAHA product owners that any service required should be performed by an authorized YAMAHA Retailer or the appointed service representative.

IMPORTANT: The presentation or sale of this manual to any individual or firm does not constitute authorization, certification or recognition of any applicable technical capabilities, or establish a principle-agent relationship of any form.

The data provided is believed to be accurate and applicable to the unit(s) indicated on the cover. The research, engineering, and service departments of YAMAHA are continually striving to improve YAMAHA products. Modifications are, therefore, inevitable and specifications are subject to change without notice or obligation to retrofit. Should any discrepancy appear to exist, please contact the distributor's Service Division.

WARNING: Static discharges can destroy expensive components. Discharge any static electricity your body may have accumulated by grounding yourself to the ground buss in the unit (heavy gauge black wires connect to this buss).

IMPORTANT: Turn the unit OFF during disassembly and part replacement. Recheck all work before you apply power to the unit.

■ CONTENTS

TO SERVICE PERSONNEL	2	DISPLAY DATA	30-31
FRONT PANELS	3	IC DATA	32-47
REAR PANELS	4-5	BLOCK DIAGRAMS	49-50
REMOTE CONTROL PANELS	6	PIN CONNECTION DIAGRAMS	51
SPECIFICATIONS	7-9	PRINTED CIRCUIT BOARDS	52-66
INTERNAL VIEW	10	SCHEMATIC DIAGRAMS	67-80
DISASSEMBLY PROCEDURES	10-12	REPLACEMENT PARTS LIST	81-91
UPDATING FIRMWARE	13-14	REMOTE CONTROL	92-93
SELF DIAGNOSIS FUNCTION (DIAG)	15-29	Advanced setup	94



このサービスマニュアルは、エコマーク認定の再生紙を使用しています。
This Service Manual uses recycled paper.

101048

© 2007 YAMAHA CORPORATION. All rights reserved.
This manual is copyrighted by YAMAHA and may not be copied or
redistributed either in print or electronically without permission.



YAMAHA

YAMAHA CORPORATION
P.O.Box 1, Hamamatsu, Japan

'07.07

RX-V461/HTR-6040/
RX-V461DAB

■ TO SERVICE PERSONNEL

1. Critical Components Information

Components having special characteristics are marked  and must be replaced with parts having specifications equal to those originally installed.

2. Leakage Current Measurement (For 120V Models Only)

When service has been completed, it is imperative to verify that all exposed conductive surfaces are properly insulated from supply circuits.

- Meter impedance should be equivalent to 1500 ohms shunted by 0.15µF.

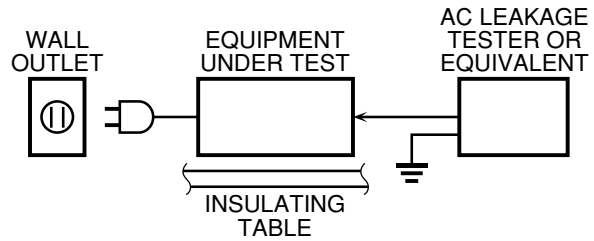

- Leakage current must not exceed 0.5mA.
- Be sure to test for leakage with the AC plug in both polarities.

WARNING: CHEMICAL CONTENT NOTICE!

The solder used in the production of this product contains LEAD. In addition, other electrical/electronic and/or plastic (where applicable) components may also contain traces of chemicals found by the California Health and Welfare Agency (and possibly other entities) to cause cancer and/or birth defects or other reproductive harm.

DO NOT PLACE SOLDER, ELECTRICAL/ELECTRONIC OR PLASTIC COMPONENTS IN YOUR MOUTH FOR ANY REASON WHATSOEVER!

Avoid prolonged, unprotected contact between solder and your skin! When soldering, do not inhale solder fumes or expose eyes to solder/flux vapor!

If you come in contact with solder or components located inside the enclosure of this product, wash your hands before handling food.

About lead free solder

All of the P.C.B.s installed in this unit and solder joints are soldered using the lead free solder.

Among some types of lead free solder currently available, it is recommended to use one of the following types for the repair work.

- Sn + Ag + Cu (tin + silver + copper)
- Sn + Cu (tin + copper)
- Sn + Zn + Bi (tin + zinc + bismuth)

Caution:

As the melting point temperature of the lead free solder is about 30°C to 40°C (50°F to 70°F) higher than that of the lead solder, be sure to use a soldering iron suitable to each solder.

RX-V461/HTR-6040/
RX-V461DAB

FRONT PANELS

RX-V461 (T, G, E models)

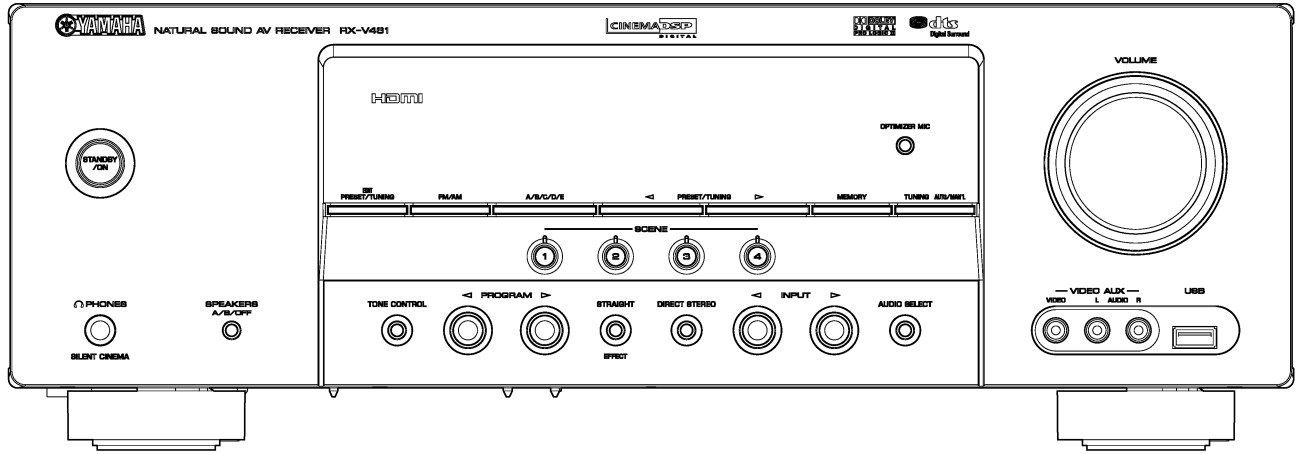

HTR-6040 (T, G, E models)

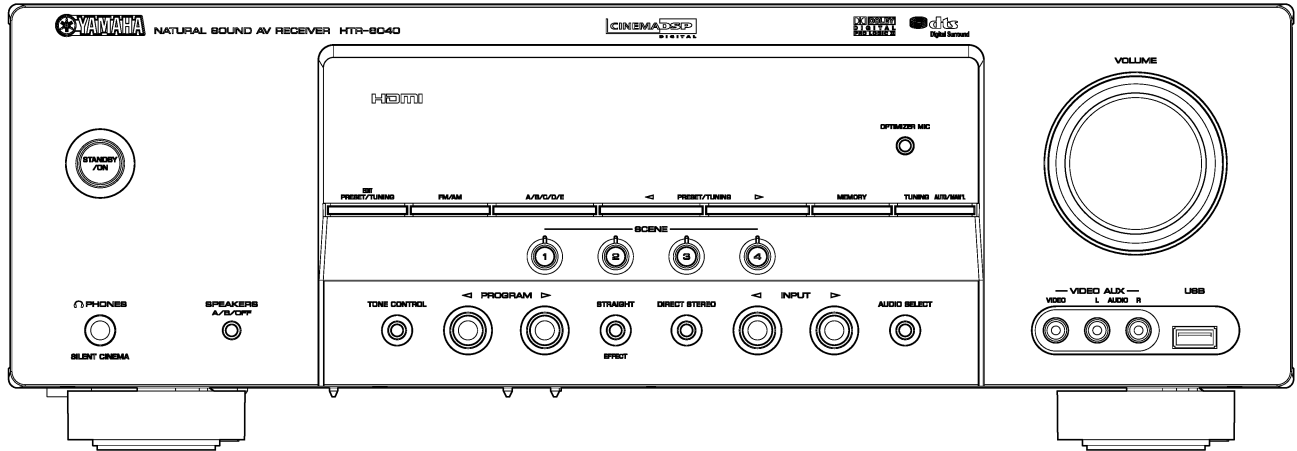

RX-V461DAB (B model)

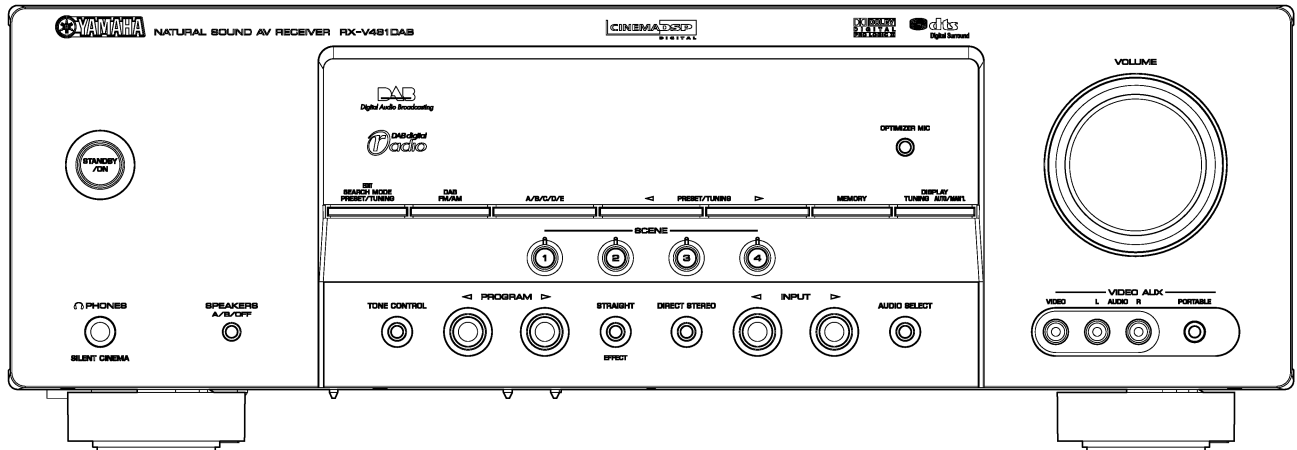

RX-V461/HTR-6040/
RX-V461DAB

REAR PANELS

RX-V461 (T model)

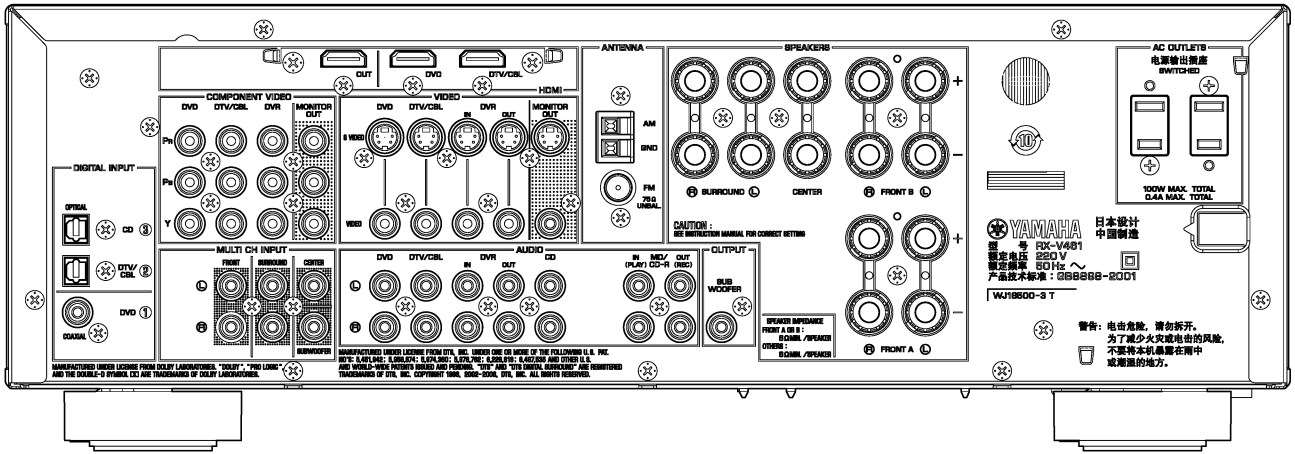

RX-V461 (G, E models)

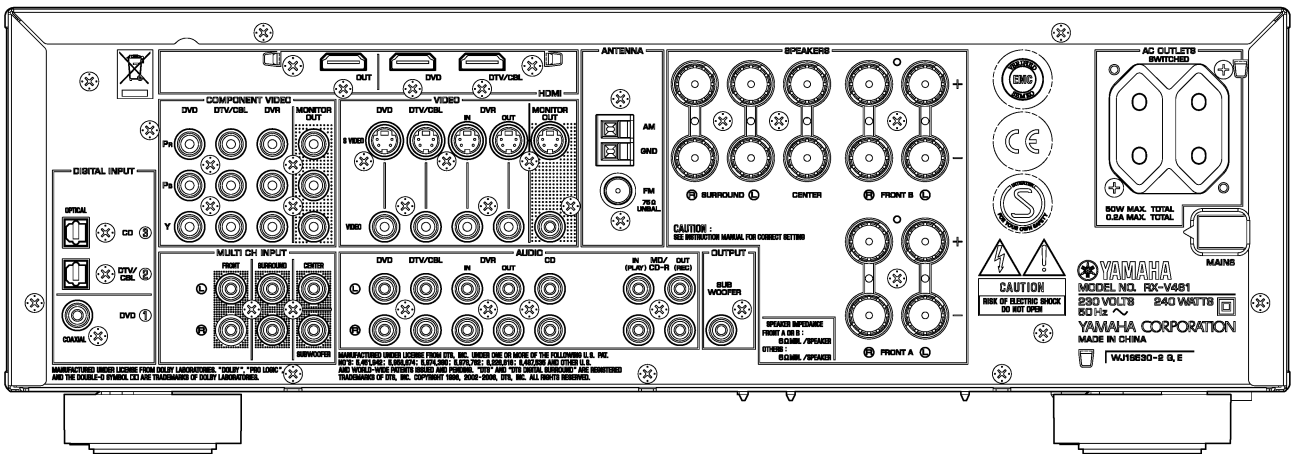

HTR-6040 (T model)

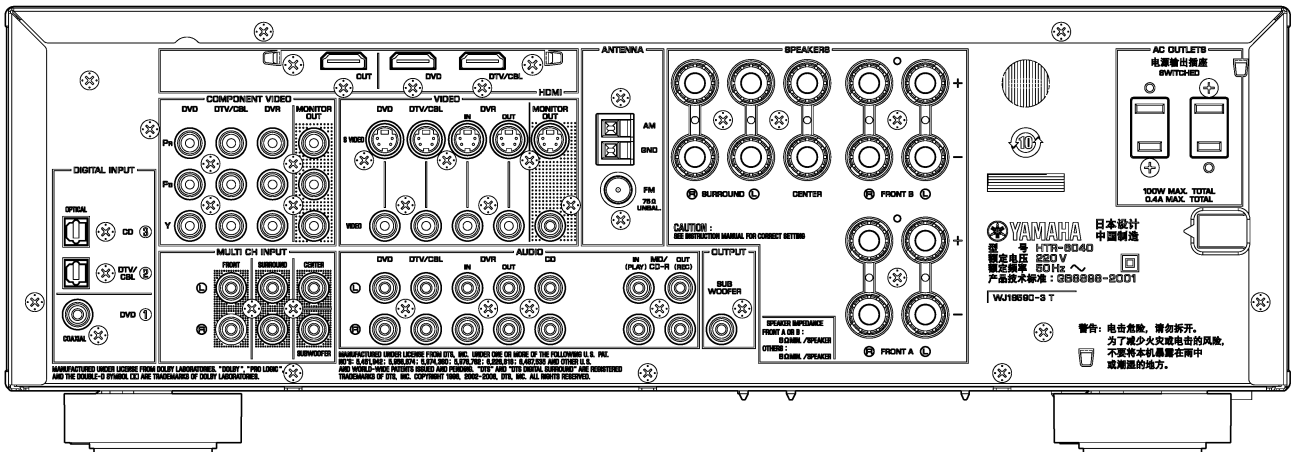

RX-V461/HTR-6040/
RX-V461DAB

HTR-6040 (G, E models)

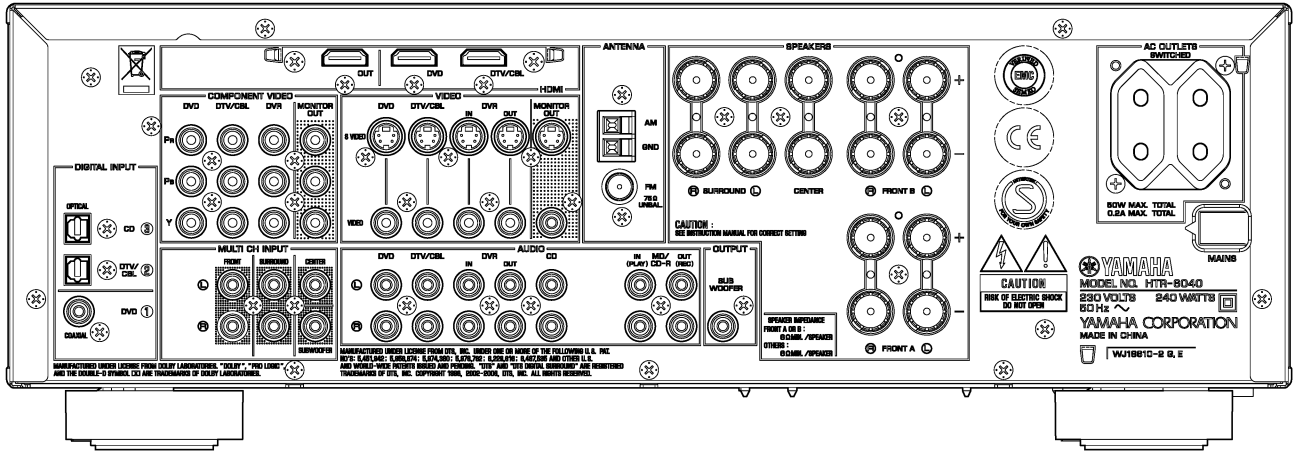

RX-V461DAB (B model)

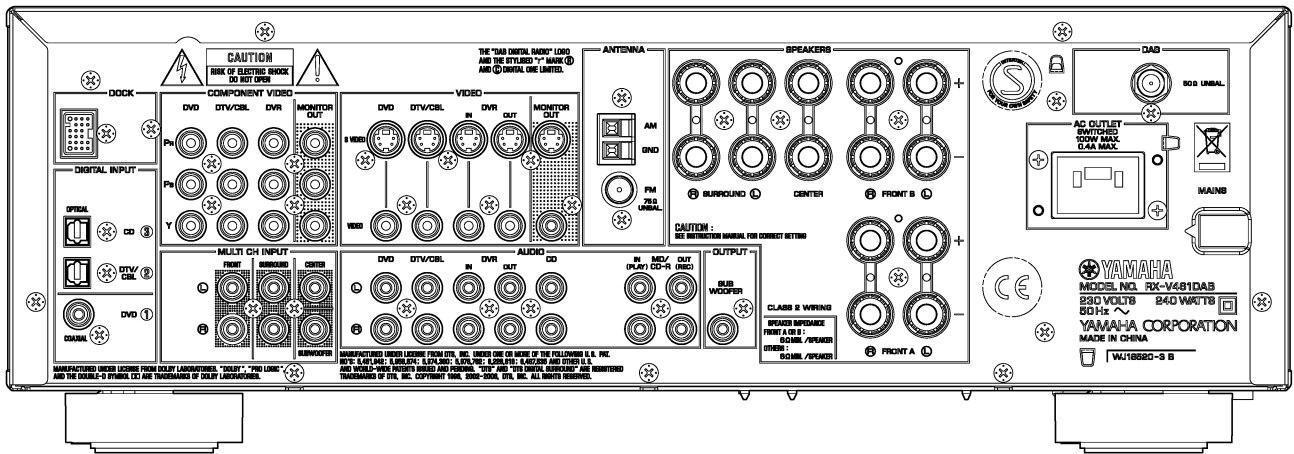

RX-V461/HTR-6040/
RX-V461DAB

■ REMOTE CONTROL PANELS

- RAV315
RX-V461 (T, G, E models)
HTR-6040 (T, G, E models)

- RAV310
RX-V461DAB (B model)

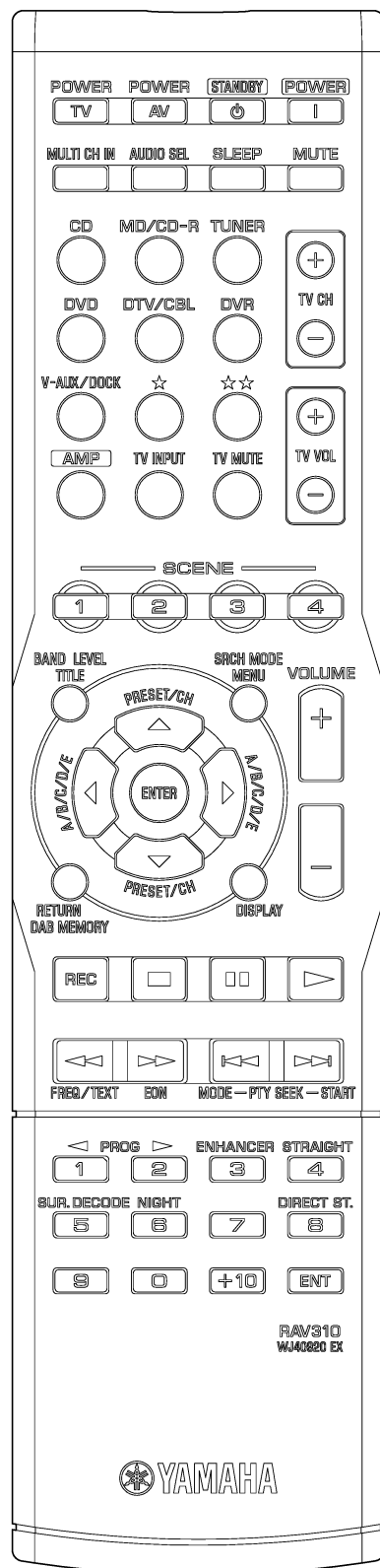
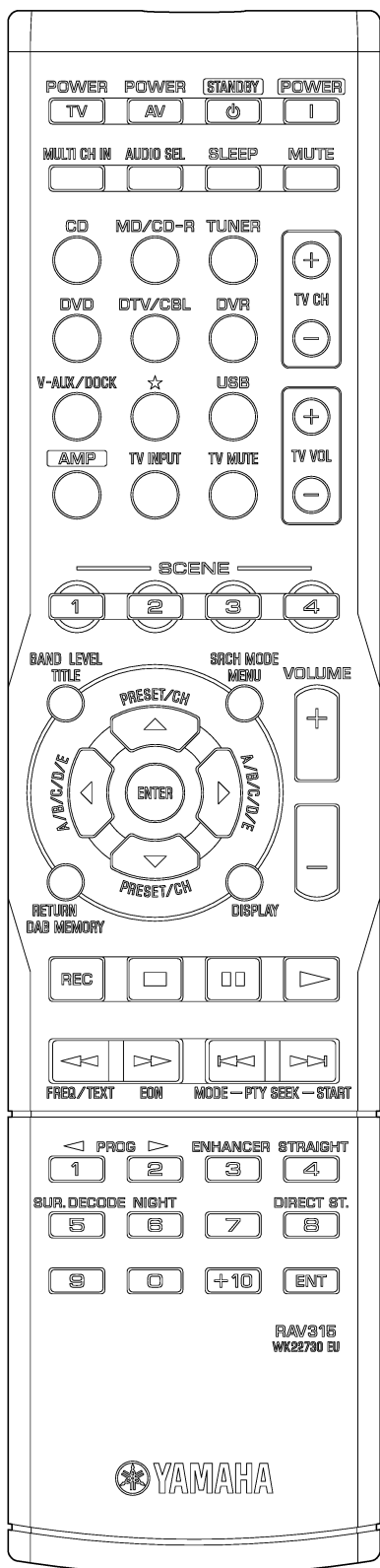

■ SPECIFICATIONS

■ Audio Section

Minimum RMS Output Power (Power Amp. Section)

FRONT L/R, CENTER, SURROUND L/R
1 kHz, 0.9 % THD, 6 ohms 100 W/ch

Maximum Power (JEITA)

FRONT L/R, CENTER, SURROUND L/R
1 kHz, 10 % THD, 6 ohms 135 W/ch

Dynamic Power Per Channel (IHF)

6/4/2 ohms 105/130/150 W

Input Sensitivity/Input Impedance (1 kHz, 100 W, 8 ohms)

CD, etc. 200 mV / 47 k-ohms

MULTI CH INPUT

FRONT L/R, CENTER, SURROUND L/R, SUBWOOFER
..... 200 mV / 47 k-ohms

Maximum Input Signal (1 kHz, 0.5 % THD, Effect on)

CD, etc. 2.0 V or more

Output Level/Output Impedance

REC OUT 200 mV / 1.2 k-ohms

SUBWOOFER (2 ch STEREO and FRONT SP: Small)
..... 4 V / 1.2 k-ohms

Headphone Jack Rated Output/Impedance

CD, etc. (1 kHz, 200 mV, 8 ohms) 0.4 V / 470 ohms

Frequency Response (10 Hz to 100 kHz)

CD, etc. to FRONT L/R 0 / -3.0 dB

Total Harmonic Distortion (Direct stereo to FRONT L/R SP OUT)

1 kHz, 50 W, 6 ohms 0.06 % or less

Signal to Noise Ratio (IHF-A Network)

(Direct stereo to input shorted SP OUT)

200 mV 98 dB or more

250 mV 100 dB or more

Residual Noise (IHF-A Network)

FRONT L/R SP OUT 150 µV or less

Channel Separation (Input 5.1 k-ohms shorted, 1 kHz / 10 kHz)

CD, etc. 60 dB or more / 45 dB or more

Tone Control Characteristics

BASS

Boost/Cut ±10 dB (100 Hz)

TREBLE

Boost/Cut ±10 dB (20 kHz)

Filter Characteristics

FRONT, CENTER, SURROUND, SURROUND BACK small (H.P.F.)

..... fc=40/60/80/90/100/110/120/160/200 Hz, 12 dB/oct.

SUBWOOFER (L.P.F.)

..... fc=40/60/80/90/100/110/120/160/200 Hz, 24 dB/oct.

Multimedia (USB) Applications

T, G, E models Connections USB mass storage class device

Playback Formats (USB device)

T, G, E models WAV (PCM format), MP3, WMA

Supported USB Devices (FAT16 or FAT32 format)

T, G, E models USB memory device, Portable audio player

■ Video Section

Video Signal Type (Gray Back)

..... PAL

Composite Video Signal Level

..... 1 Vp-p / 75 ohms

S-Video Signal Level

Y 1 Vp-p / 75 ohms

C 0.286 Vp-p / 75 ohms

Component Video Signal Level

Y 1 Vp-p / 75 ohms

Pb/Pr 0.7 Vp-p / 75 ohms

Video Maximum Input Level

..... 1.5 Vp-p or more

Signal to Noise Ratio (IHF)

..... 50 dB or more

Monitor Out Frequency Response (VIDEO CONV. OFF)

Component video signal 5 Hz to 60 MHz, -3 dB

HDMI (HDMI 1.2a)

T, G, E models Type A (IN x 2, OUT x 1)

■ FM Section

Tuning Range

..... 87.50 to 108.00 MHz

50dB Quieting Sensitivity (IHF) (1 kHz, 100 % Mod.)

Mono

T, G, E models 2.8 µV (20.2 dBf)

B model 2.0 µV (17.3 dBf)

Signal to Noise Ratio (IHF)

Mono

T, G, E models 73 dB

B model 76 dB

Stereo

..... 70 dB

Harmonic Distortion (1 kHz)

Mono / Stereo

T, G, E models 0.5 % / 0.5 %

B model 0.2 % / 0.3 %

Antenna Input

..... 75 ohms unbalanced

■ AM Section

Tuning Range

..... 531 to 1,611 kHz

Sensitivity (B model)

..... 300 µV/m

Antenna Input

..... Loop antenna

■ DAB Section (B model)

Tuning Range

Band III 174 to 240 MHz

L-Band 1,452 to 1,492 MHz

Sensitivity

Band III -99 dBm

L-Band -95 dBm

Selectivity (For adjacent channel)

Band III / L-Band 40 dB

Signal to Noise Ratio

..... 97 dB

Total Harmonic Distortion

..... 0.01 %

Stereo Separation

1 kHz 95 dB

Frequency Response

20 Hz to 20 kHz +0.5/-0.5 dB

Antenna Input

..... 75 ohms unbalanced

■ General

Power Supply

T model AC 220 V, 50 Hz

B, G, E models AC 230 V, 50 Hz

Power Consumption

..... 240 W

Standby Power Consumption (reference data)

..... 0.8 W

AC Outlets

2 switched outlets

T model 100 W max. total

G, E models 50 W max. total

1 switched outlet

B model 50 W max. total

Dimensions (W x H x D)

..... 435 x 151 x 317.6 mm (17-1/8" x 5-15/16" x 12-1/2")

Weight

..... 8.1 kg (17 lbs. 14 oz.)

Finish

[RX-V461]

Gold color T model

Black color G, E models

Titanium color G, E models

[HTR-6040]

Gold color T model

Black color G model

Silver color G, E models

[RX-V461DAB]

Black color B model

Titanium color B model

Accessories

Remote control x 1, Batteries (R03, AAA, UM-4) x 2, Indoor FM antenna x 1, AM loop antenna x 1, Optimizer microphone x 1, DAB wire antenna x 1 (B model)

* Specifications are subject to change without notice due to product improvements.

T Chinese model
G European model

B British model
E South European model



Manufactured under license from Dolby Laboratories.

"Dolby", "Pro Logic", and the double-D symbol are trademarks of Dolby Laboratories.

SILENT™
CINEMA

"SILENT CINEMA" is a trademark of YAMAHA CORPORATION.



"HDMI", the "HDMI" logo and "High-Definition Multimedia Interface" are trademarks or registered trademarks of HDMI Licensing LLC.



"DTS" and "DTS Digital Surround" are registered trademarks of DTS, Inc.

iPod™

"iPod" is a trademark of Apple Computer, Inc., registered in the U.S. and other countries.



The "DAB Digital Radio" logo and the stylised "r" mark ® and © Digital One Limited.



Digital Audio Broadcasting

This receiver supports DAB tuning.

• DIMENSIONS

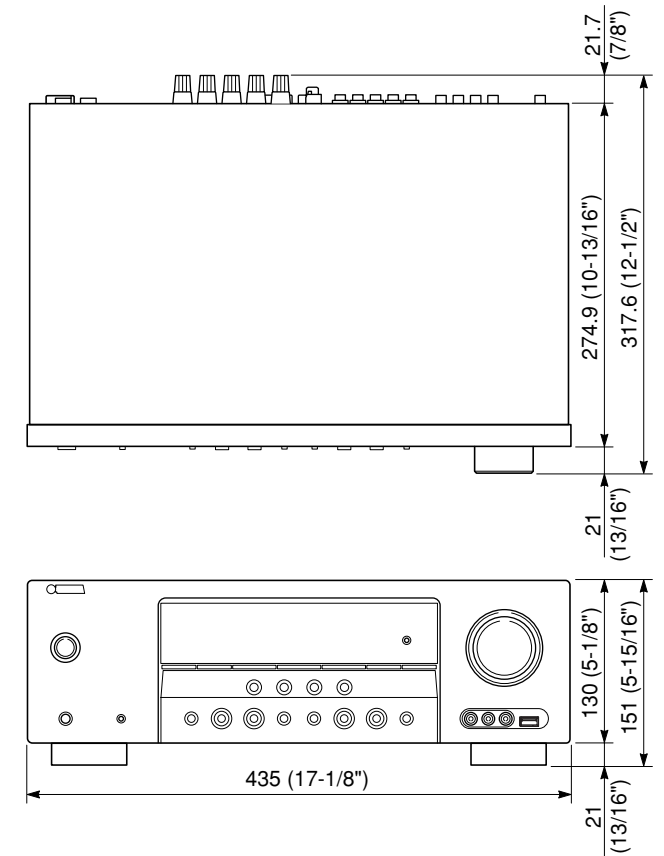

Unit: mm (inch)

• **SCENE TEMPLATE**

SCENE name	Contents		Source	Program		Select (Default)		
				Mode	Sub-mode	T model	B model	G, E models
DVD Viewing	DVD	Movie	DVD	STRAIGHT	–	<input type="radio"/>	<input type="radio"/>	<input type="radio"/>
DVD Movie Viewing			DVD	MOVIE THEATER	Movie Dramatic	<input type="radio"/> (SCENE 1)	<input type="radio"/> (SCENE 1)	<input type="radio"/> (SCENE 1)
DVD Live Viewing			DVD	MUSIC	Pop/Rock	<input type="radio"/>	<input type="radio"/>	<input type="radio"/>
DVR Viewing	DVR		DVR	MOVIE THEATER	Movie Dramatic	<input type="radio"/>	<input type="radio"/>	<input type="radio"/>
Disc Hi-fi Listening	DVD-Audio / SA-CD / CD	Music Disc	DVD	DIRECT STEREO	–	<input type="radio"/>	<input type="radio"/>	<input type="radio"/>
Music Disc Listening			DVD	STEREO	2ch Stereo	<input type="radio"/> (SCENE 2)	<input type="radio"/> (SCENE 2)	<input type="radio"/> (SCENE 2)
Disc Listening			DVD	STEREO	5ch Stereo	<input type="radio"/>	<input type="radio"/>	<input type="radio"/>
CD Hi-fi Listening	CD	Music Disc	CD	DIRECT STEREO	–	<input type="radio"/>	<input type="radio"/>	<input type="radio"/>
CD Listening			CD	STEREO	2ch Stereo	<input type="radio"/>	<input type="radio"/>	<input type="radio"/>
CD Music Listening			CD	STEREO	5ch Stereo	<input type="radio"/>	<input type="radio"/>	<input type="radio"/>
Radio Listening	TUNER/RADIO	FM/AM	FM/AM (TUNER)	MUSIC ENHANCER	5ch Stereo	<input type="radio"/> (SCENE 4)	<input type="radio"/> (SCENE 4)	<input type="radio"/> (SCENE 4)
DAB Listening		DAB	DAB (TUNER)	MUSIC ENHANCER	5ch Stereo	–	<input type="radio"/>	–
iPod Listening	DIGITAL AUDIO PLAYER	iPod	DOCK (V-AUX)	MUSIC ENHANCER	5ch Stereo	<input checked="" type="radio"/>	<input type="radio"/>	<input checked="" type="radio"/>
USB Audio Listening		USB	USB	MUSIC ENHANCER	5ch Stereo	<input type="radio"/>	–	<input type="radio"/>
TV Viewing	TV		DTV/CBL	STRAIGHT	–	<input type="radio"/> (SCENE 3)	<input type="radio"/> (SCENE 3)	<input type="radio"/> (SCENE 3)
TV Sports Viewing			DTV/CBL	ENTERTAINMENT	TV Sports	<input type="radio"/>	<input type="radio"/>	<input type="radio"/>
Game Playing	GAME		V-AUX	ENTERTAINMENT	Game	<input type="radio"/>	<input type="radio"/>	<input type="radio"/>

• **SOUND/SURROUND SELECT MENU**

Sound Field Parameters

		DSP LEVEL MIN, [MID], MAX	MUSIC ENHANCER LOW, [HIGH]
STEREO	2ch Stereo		
	5ch Stereo		
MUSIC	Pop/Rock	<input type="radio"/>	
	Hall	<input type="radio"/>	
	Jazz	<input type="radio"/>	
ENTERTAIN	Game	<input type="radio"/>	
	TV Sports	<input type="radio"/>	
MOVIE	Movie Spacious	<input type="radio"/>	
	Movie Dramatic	<input type="radio"/>	
MUSIC ENHANCER	Music Enh. 2ch		<input type="radio"/>
	Music Enh. 5ch		<input type="radio"/>

Surround Decoders

		PANORAMA ON, [OFF]	DIMENSION -3, [STD], +3	CENTER WIDTH 0, 1, 2, [3], 4, 5, 6, 7
DECODING FORMAT	Dolby Digital			
	DTS			
POST DECODING FORMAT	Dolby Pro-Logic			
	Dolby Pro Logic II Music	<input type="radio"/>	<input type="radio"/>	<input type="radio"/>
	Dolby Pro Logic II Movie			
	Dolby Pro Logic II Game			

• SET MENU TABLE

CATEGORY	MAIN MENU	SUB MENU	SELECT MENU	VALUE [INITIAL]
AUTO SETUP	Use this feature to automatically adjust speaker and system parameters.			
MANUAL SETUP	1 SOUND MENU	A) SPEAKER SET	FRONT B : FRONT	[FRONT] / ZONE B
			FRONT SP : LARGE	SMALL / [LARGE]
			CENTER SP : SML	NONE / [SML] / LRG
			SUR. L/R SP : SML	NONE / [SML] / LRG
			LFE/BASS OUT : BOTH	SWFR / FRONT / [BOTH]
			CROSSOVER : 80 Hz	40 / 60 / [80] / 90 / 100 / 110 / 120 / 160 / 200 Hz
			SUBWOOFER PHASE : NORMAL	[NORMAL] / REVERSE
	B) SPEAKER LEVEL		FL ***** *****	
			FR ***** *****	
			C ***** *****	
			SL ***** *****	
			SR ***** *****	
			SWFR ***** *****	
	C) SP DISTANCE		UNIT : feet	feet / meters
			FRONT L : 10.0 ft	
		FRONT R : 10.0 ft		
		CENTER : 10.0 ft		
		SUR. L : 10.0 ft		feet : 1.0 to 80.0 ft [10.0 ft], 0.5 ft step
		SUR. R : 10.0 ft		
		SWFR : 10.0 ft		
		FRONT L : 3.00 m		
		FRONT R : 3.00 m		
		CENTER : 3.00 m		
		SUR. L : 3.00 m		meters : 0.30 to 24.00 m [3.00 m], 0.10 m step
		SUR. R : 3.00 m		
		SWFR : 3.00 m		
	D) CENTER GEQ		TEST : > OFF ON	[OFF] / ON
			100 Hz -- -- 0 dB	
		300 Hz -- -- 0 dB		
		1 kHz -- -- 0 dB		
		3 kHz -- -- 0 dB		-6.0 dB to +6.0 dB [0 dB], 0.5 dB step
		10 kHz -- -- 0 dB		
	E) LFE LEVEL		SPEAKER : 0 dB	-20 dB to 0 dB [0 dB], 1 dB step
			HEADPHONE : 0 dB	-20 dB to 0 dB [0 dB], 1 dB step
	F) DYNAMIC RANGE		SP D. R. : MAX	MIN / STD / [MAX]
			HP D. R. : MAX	MIN / STD / [MAX]
	G) AUDIO SET		MUTE TYPE : FULL	[FULL] / -20 dB
			A. DELAY : 0 ms	[0 ms] to 160 ms, 1 ms step
			MAX VOL. : +16 dB	[+16 dB] / +10 dB / +5 dB / 0 dB / -5 dB / -10 dB / -15 dB / -20 dB / -25 dB / -30 dB
			INI. VOL. : OFF	[OFF] / -80 dB to +16 dB, 1 dB step
2 INPUT MENU	A) INPUT ASSIGN		COAXIAL IN (1) : DVD	CD / MD/CD-R / [DVD] / DTV/CBL / V-AUX / DVR
			OPTICAL IN (2) : DTV/CBL	CD / MD/CD-R / DVD / [DTV/CBL] / V-AUX / DVR
			OPTICAL IN (3) : CD	[CD] / MD/CD-R / DVD / DTV/CBL / V-AUX / DVR
B) INPUT RENAME				CD / MD/CD-R / DVD / DTV/CBL / V-AUX / DVR
				Input is possible to 8 characters Input possible Character type: Capital/ A to Z, Small/ a to z, Figure/ 0 to 9, Space, Marks/ # * + , - . / : < > ?
C) VOLUME TRIM				CD / MD/CD-R / TUNER / DVD / DTV/CBL / V-AUX / DVR / DOCK (B model) / MULTI CH INPUT
				-6.0 dB to +6.0 dB, [0.0 dB], 1.0 dB step
D) DECODER MODE				[AUTO] / LAST
				[AUTO] / DTS
E) MULTI CH SET				[LAST] / DVR / V-AUX / DTV/CBL / DVD
	A) INIT SCAN		SCAN : FULL	[FULL] / UK BAND3
			Execution confirmation	"SCAN? [ENTER]"
			Progress display	0 to 100%, "BREAK? [ENTER]"
			Result display	"FINISH [xxx]"
B) TUNE AID				"5A LEVEL: XX", "5B LEVEL: XX"
				[AUTO] / OFF
C) DRC MODE				"OK? [ENTER]"
				"FINISH", "DELETE FAILED"
D) PRUNE LIST				"DELETE --", 1 to 99
				"OK? [ENTER]"
E) PRESET DEL				"FINISH", "DELETE FAILED"
				-4 to [0], 1 step
3 OPTION MENU (T, G, E models)	A) DISPLAY SET		DIMMER : 0	[CONT] / ONCE
			FL SCROLL : CONT	-5 to +5, [0], 1step
4 OPTION MENU (B model)			OSD-SOURCE : 30 s	10s / [30s] / ON
			OSD-AMP : 30 s	10s / [30s] / ON
B) MEMORY GUARD			MEMORY GUARD : OFF	[OFF] / ON
			DEFAULT : AUTO	[AUTO] / LAST
C) AUDIO SELECT				[NO] / YES
				[OFF] / SINGLE / ALL
D) PARAM. INI				[OFF] / ON
E) USB PLAY STYLE (T, G, E models)				
SIGNAL INFO	1 FORMAT (Signal format)			Analog / PCM / DolbyD / DTS / Digital / --- / ???
	2 SAMPLING			xxx kHz
	3 CHANNEL			3/2/0.1 (Front/Surround/LFE) / 1+1
	4 BITRATE (Bit rate)			xxx kbps
	5 FLAG			DolbyD / DTS / PCM / None

INTERNAL VIEW

Top view

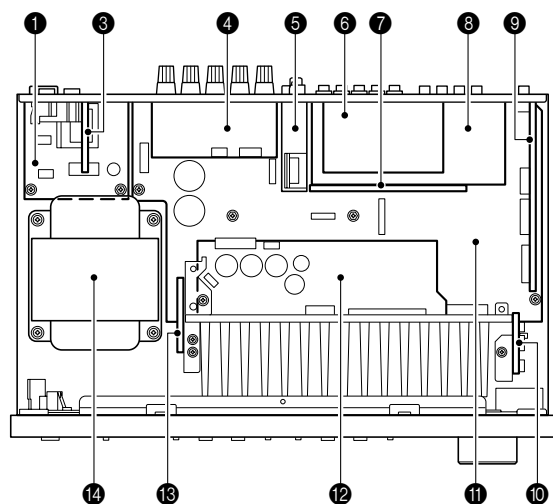
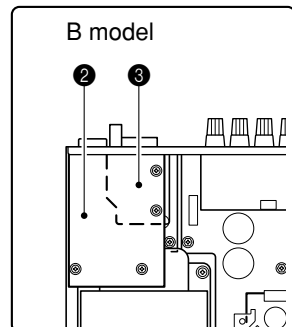

Front view

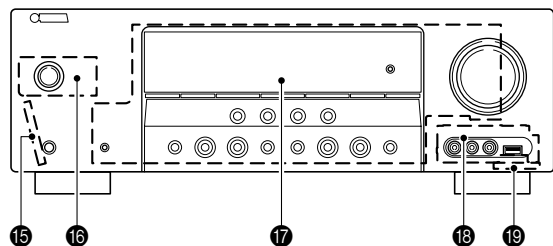

Rear view

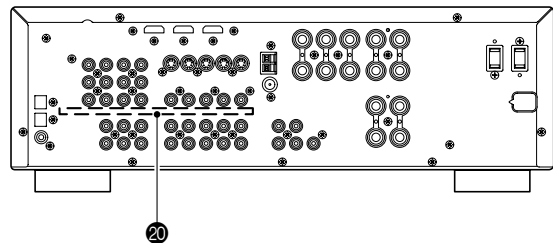

- ① OPERATION (3) P.C.B.
- ② DAB P.C.B. (B model)
- ③ OPERATION (4) P.C.B.
- ④ VIDEO (4) P.C.B.
- ⑤ Tuner
- ⑥ HDMI P.C.B. (T, G, E models)
- ⑦ VIDEO (3) P.C.B.
- ⑧ VIDEO (1) P.C.B.
- ⑨ DSP P.C.B.
- ⑩ MAIN (4) P.C.B.
- ⑪ MAIN (1) P.C.B.
- ⑫ OPERATION (2) P.C.B.
- ⑬ OPERATION (11) P.C.B.
- ⑭ Power Transformer
- ⑮ OPERATION (6) P.C.B.
- ⑯ OPERATION (10) P.C.B.
- ⑰ OPERATION (1) P.C.B.
- ⑱ OPERATION (7) P.C.B. (B model)
OPERATION (8) P.C.B. (T, G, E models)
- ⑲ OPERATION (9) P.C.B. (T, G, E models)
- ⑳ VIDEO (2) P.C.B.

DISASSEMBLY PROCEDURES

(Remove parts in the order as numbered.)
Disconnect the power cable from the AC outlet.

1. Removal of Top Cover

- a. Remove 4 screws (①), 4 screws (②) and 1 screw (③). (Fig. 1)
- b. Slide the top cover rearward to remove it. (Fig. 1)

2. Removal of Front Panel Unit

- a. Remove 6 screws (④). (Fig. 1)
- b. Remove CB191, CB192, CB235, CB261 and CB408. (Fig. 1)
- c. Remove the front panel unit. (Fig. 1)

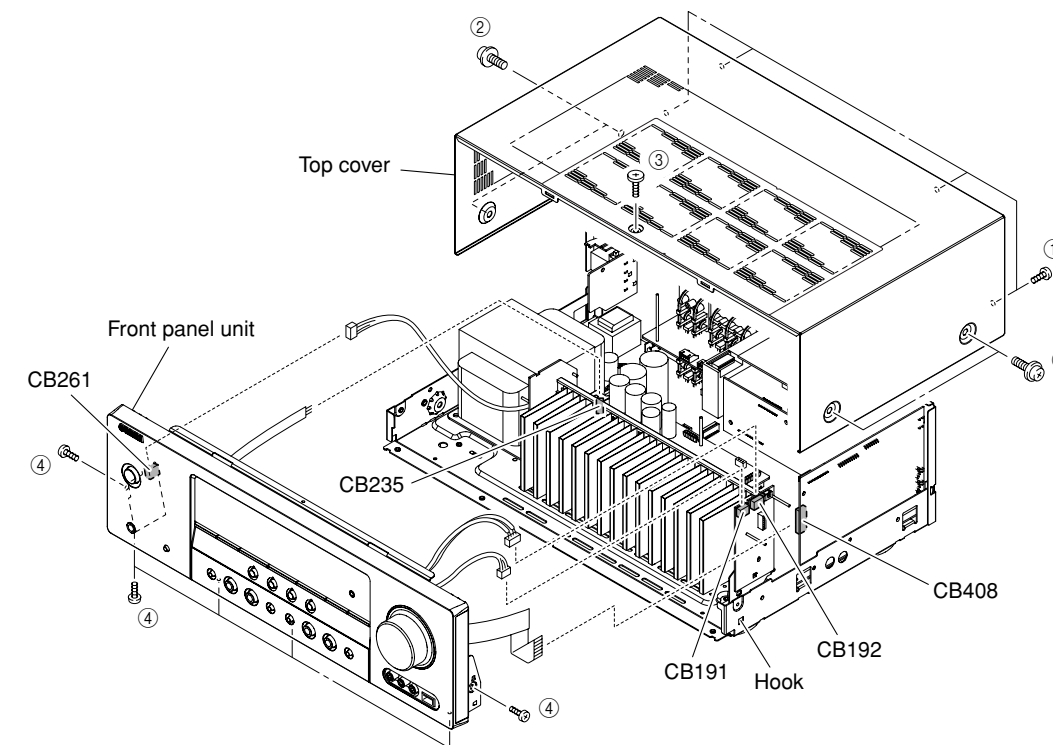

Fig. 1

3. Removal of HDMI P.C.B. (T, G, E models)

- a. Remove CB905 and CB906. (Fig. 2)
- b. Remove 5 screws (⑤). (Fig. 3)
- c. Remove HDMI P.C.B.. (Fig. 2)

4. Removal of DAB P.C.B. (B model)

- a. Remove screw (⑥). (Fig. 3)
- b. Remove nut and washer. (Fig. 3)
- c. Remove CB301, CB361 and CB362. (Fig. 2)
- d. Remove DAB P.C.B.. (Fig. 2)

5. Removal of VIDEO (1), (2) and (3) P.C.B.s

- a. Remove CB193, CB305 and CB322. (Fig. 2)
- b. Remove 11 screws (⑦). (Fig. 3)
- c. Remove VIDEO (1), (2) and (3) P.C.B.s. (Fig. 2)

6. Removal of DSP P.C.B.

- a. Remove 18 screws (T, G, E models)/19 screws (B model) (⑧), 3 screws (⑨) and 2 screws (⑩). (Fig. 3)
- b. Remove cord stopper. (Fig. 2)
- c. Remove rear panel. (Fig. 2)
- d. Remove CB512 and CB516. (Fig. 2)
- e. Remove screw (⑪). (Fig. 2)
- f. Remove the DSP P.C.B. which is connected directly to the MAIN (1) P.C.B. with connectors. (Fig. 2)

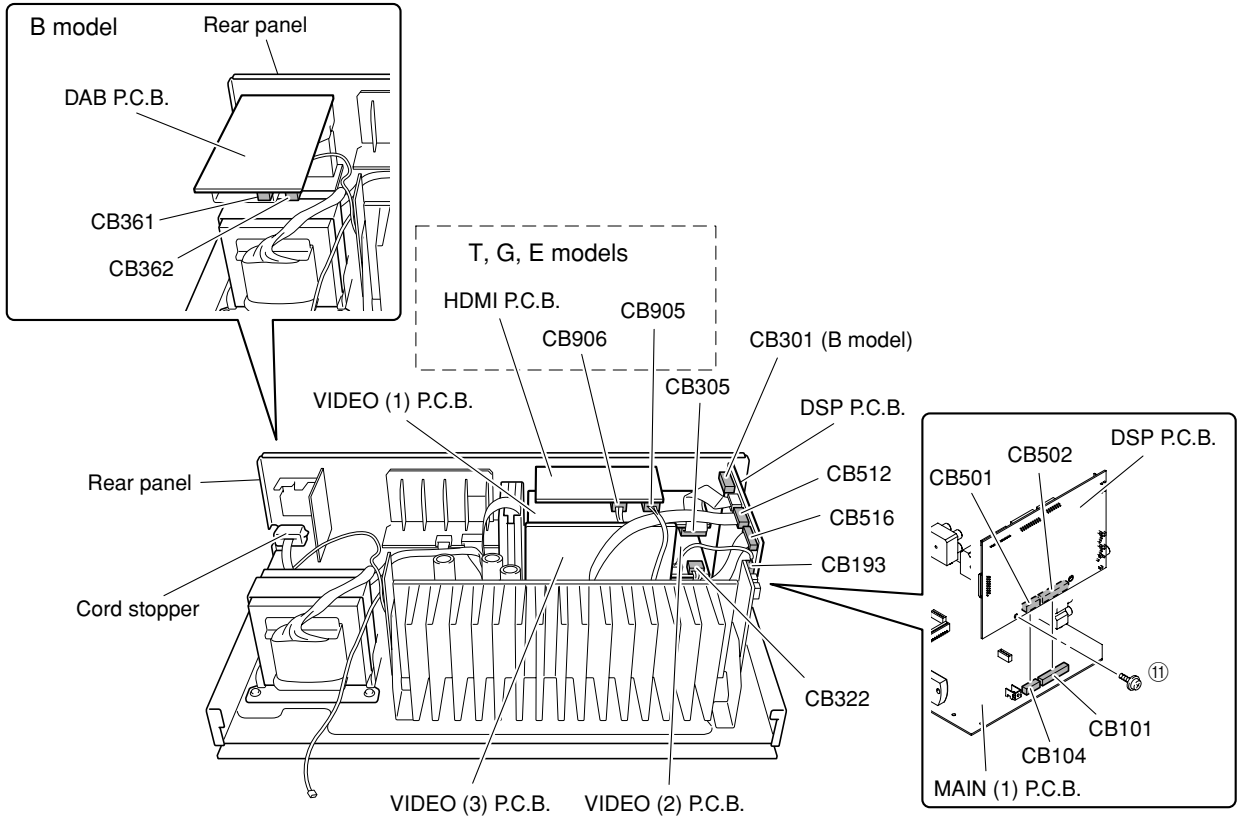
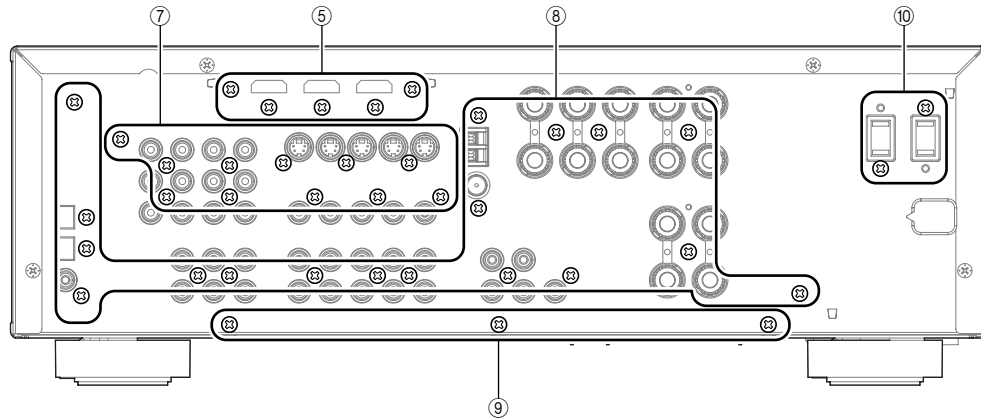

Fig. 2

T, G, E models



B model

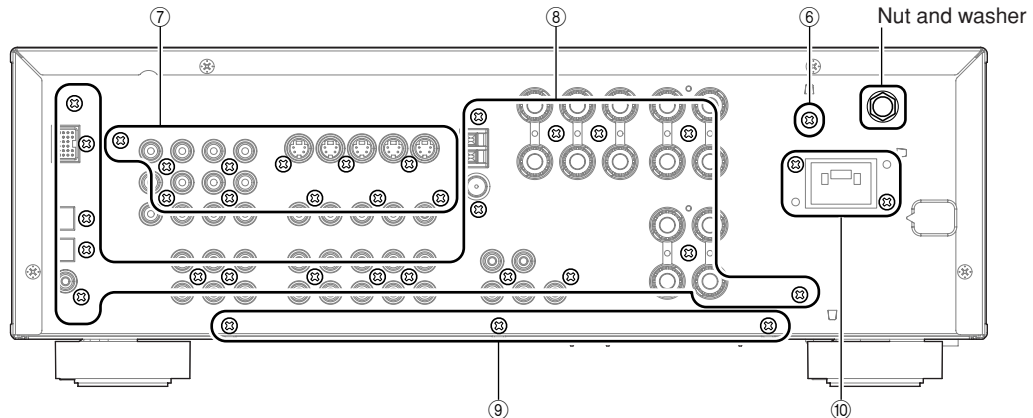

Fig. 3

When checking the P.C.B.:

- a. Remove the top cover. (Fig. 1)
- b. Remove 3 screws (9). (Fig. 3)
- c. Remove 5 screws (12) and 4 screws (13). (Fig. 4)
- d. Place the P.C.B. upright. (Fig. 5)
- e. The rear panel and P.C.B. removed from the chassis does not work because its grounding is loose.

Be sure to connect the ground of rear panel and MAIN (1) P.C.B. (G102, G103, G104 and G105) to the chassis with a ground lead or the like. (Fig. 5)

- Be sure to use the extension cable for servicing for the following section. (Fig. 6)

DSP P.C.B. CB408_OPERATION (1) P.C.B. CB202:
V2854400 (17P, 300mm)

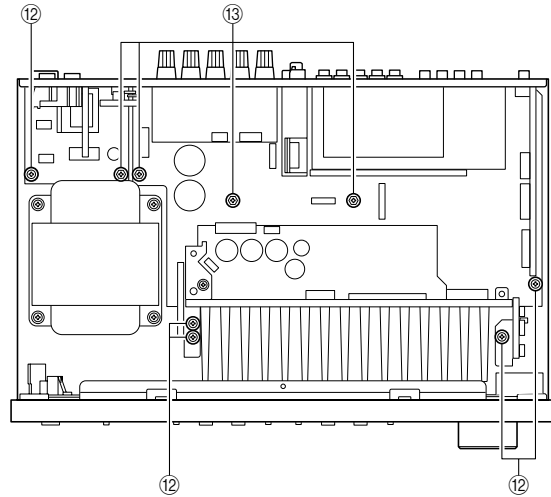

Fig. 4

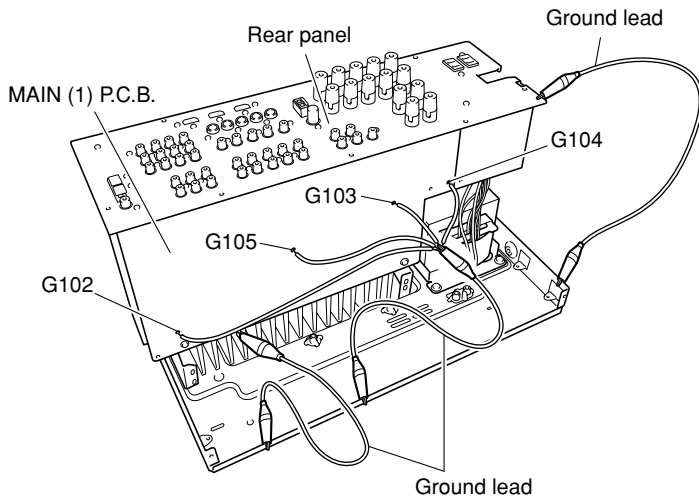

Fig. 5

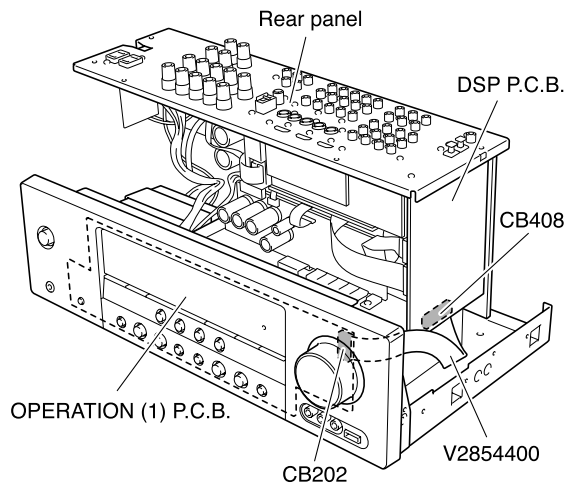

Fig. 6

RX-V461/HTR-6040/
RX-V461DAB

■ UPDATING FIRMWARE

After replacing the following parts with the replacement part, be sure to write the latest firmware.

- DSP P.C.B.
- IC201 (DSP P.C.B.)

● Required Tools

- DVD or CD player (with DIGITAL OUTPUT (OPTICAL or COAXIAL) terminal)
- Optical cable (when OPTICAL terminal is used)
- Digital audio pin cable (when COAXIAL terminal is used)
- Firmware CD
 - * To make the firmware CD, download the latest firmware from the specified download source to PC.

● Operation Procedures

1. Connect the main unit and DVD/CD player as shown below. (Fig. 1)

Example of OPTICAL terminal

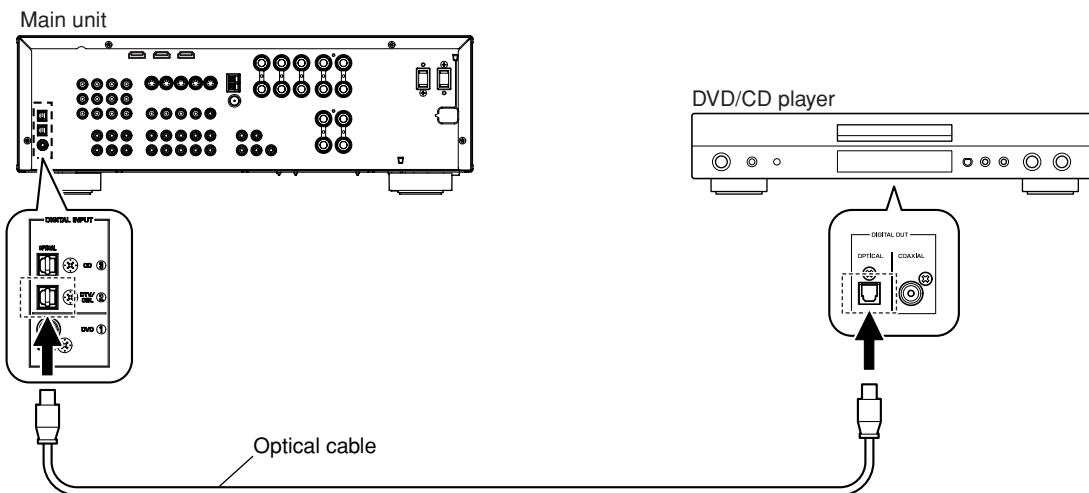

Example of COAXIAL terminal

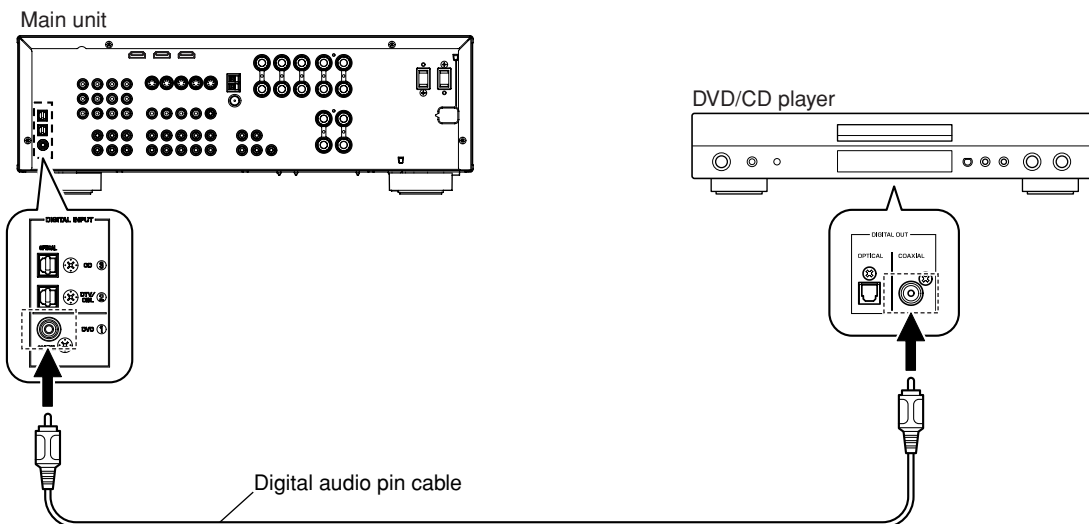

Fig. 1

2. While pressing the "STANDBY/ON" key and "SPEAKERS A/B/OFF" key of the main unit simultaneously, connect the power cable of the main unit to the AC outlet. (Fig. 2)
The FIRMWARE UPDATE mode will then be activated and "SPDIF Upgrade" is displayed. (Fig. 2)

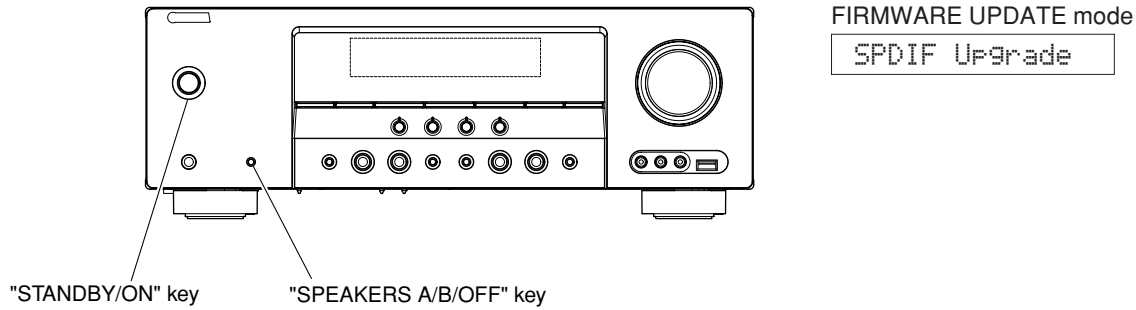

Fig. 2

3. Connect the power cable of DVD/CD player to the AC outlet.
4. Press the "STANDBY/ON" key of the DVD/CD player.
5. Press the "EJECT" key of the DVD/CD player to open the tray.
6. Put the firmware CD on the tray and close the tray.
7. Press the "PLAY" key of the DVD/CD player.
Then writing of the firmware is started. (Fig. 3)
8. When writing of the firmware is completed, "Upgrade OK", "Please..." and "Turn off!!" are displayed repeatedly. (Fig. 3)



Fig. 3

* When the version of the firmware to be written is the same as the one existing in the main unit, "Same Version", "Please..." and "Turn off!!" are displayed repeatedly. (Upgrading is not necessary.)

If the display remains unchanged for more than 10 seconds after starting the firmware CD play procedure, perform the firmware CD play procedure again from the beginning.

If "FILE CORRUPTED" is displayed after "Address:XXXXXX", check to make sure that the written data is not corrupted and perform Steps 1 to 8 of "Operation Procedures" again.

If "Upgrade Failed" is displayed, perform Steps 1 to 8 of "Operation Procedures" again.

9. Press the "STOP" key of the DVD/CD player.
10. Press the "EJECT" key of the DVD/CD player to open the tray.
11. Remove the firmware CD from the tray and close the tray.
12. Turn off the power of the DVD/CD player and disconnect the power cable from the AC outlet.
13. Turn off the power by pressing the "STANDBY/ON" key of the main unit.

* After updating the firmware, be sure to initialize the main unit.

● **Confirmation of firmware version and checksum**

Confirm that the firmware version and checksum value is updated successfully with the DIAG function.

For more information, refer to "SELF DIAGNOSIS FUNCTION (DIAG)".

* When the displayed firmware version and checksum are different from written firmware version and checksum, follow the steps from 1 to 13 of "Operation Procedures" again.

■ SELF DIAGNOSIS FUNCTION (DIAG)

This unit has self diagnosis functions that are intended for inspection, measurement and location of faulty point.

There are 18 DIAG menu items, each of which has sub-menu items.

Listed in the table below are menu items and sub-menu items.

Note that not all menu items listed will apply to the models covered in this service manual.

No.	DIAG menu	Sub-menu
1	BYPASS	ANLOG BYPASS DSP BYPASS
2	AUDIO CHECK	AUDIO CHECK
3	SPEAKERS SET	FRNT : SML 0dB CENTER NONE LFE/B : FRNT TONE : MAX TONE : MIN
4	6CH-INPUT	6ch INPUT 6-ohm 6ch INPUT 8-ohm LIM : , PLDET : , THM
5	MIC CHECK	MIC CHECK
6	FL/OSD CHECK	VFD CHECK VFD DISP OFF VFD DISP ALL VFD DIMMER CHECK PATTERN
7	TEST TONE	TEST ALL TEST FRNT L TEST CENTER TEST FRNT R TEST SURR R TEST SURR L TEST LFE
8	FACTORY PRESET	PRESET INHI PRESET RSRV
9	AD DATA CHECK	PD : , PV : TH : , PL : PI : , DE : K0 : , K1 :
10	XM STATUS (Not applied to these models.)	1k – 1dB/44 1k –61dB/44 MUTE /44 XM TONE /44 ISO TONE/44 1k – 1dB/32 1k –61dB/32 MUTE /32 XM TONE /32 ISO TONE/32 BUS PWR : OFF
11	DOCK (B model)	DOCK : DOCK IGNORE
12	USB (T, G, E models)	USB FILE 1 USB FILE 2
13	DAB (B model)	DAB SCAN DLS : Signal Q. :

No.	DIAG menu	Sub-menu
14	IF STATUS (Not applied to these models.)	IF 1 IF 2 IF 3 IF 4 IF 5 IF 6 IF 7 IF 8 IF 9 IF 10 IF 11 IF 12 IF 13 IF 14 IF 15 IF 16 IF 17
15	PROTECTION	PRD L : PRD H : PRV L : PRV H : THM : PLD8 L : PLD8 H : PLD6 L : PLD6 H : PRI PDET
16	PROTECTION HISTORY	History 1 History 2 History 3 History 4
17	SOFT SWITCH	SW MODE MODEL DESTINATION TUNER DESTINATION VIDEO FORMAT AAC (Not applied to these models.) OSD YPAO RDS XM (Not applied to these models.) DAB (B model) USB (T, G, E models) DOCK (iPod) (B model)
18	ROM VER/SUM	VERSION ALL CHECKSUM PROGRAM CHECKSUM SPI CHECKSUM SPD CHECKSUM XM VERSION (Not applied to these models.) DAB VERSION FlashROM TEST SDRAM TEST EEPROM TEST

• **Starting DIAG**

Press the “STANDBY/ON” key while simultaneously pressing those two keys of the main unit as indicated in the figure below.

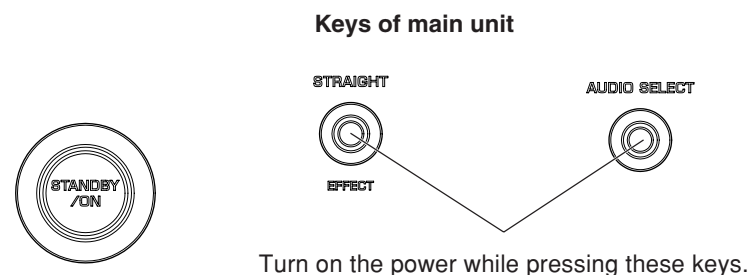

• **Starting DIAG in the protection cancel mode**

If the protection function works and causes hindrance to trouble diagnosis, cancel the protection function as described below, and it will be possible to enter the DIAG mode. (The protection functions other than the excess current detect function will be disabled.)

Press the “STANDBY/ON” key while simultaneously pressing those two keys indicated in the figure above. At this time, keep pressing those two keys for 3 seconds or longer. In this mode, the [SLEEP] segment of the FL display of the main unit flashes to indicate that the mode is DIAG mode with the protection functions disabled.

CAUTION!
Using this product with the protection function disabled may cause damage to the main unit. Use special care for this point when using this mode.

• **Canceling DIAG**

1. Before canceling DIAG, execute setting for FACTORY PRESET of DIAG menu No.8 (Memory initialization inhibited or Memory initialized).
 - * In order to keep the user memory stored, be sure to select PRESET INHIBITED (Memory initialization inhibited).
2. Turn off the power by pressing the “STANDBY/ON” key of the main unit.

• **Display provided when DIAG started**

On the FL display of the main unit, an opening message (including the protection history) appears for a few seconds followed by the DIAG menu display (1. ANALOG BYPASS).

When there is no history of protection function:

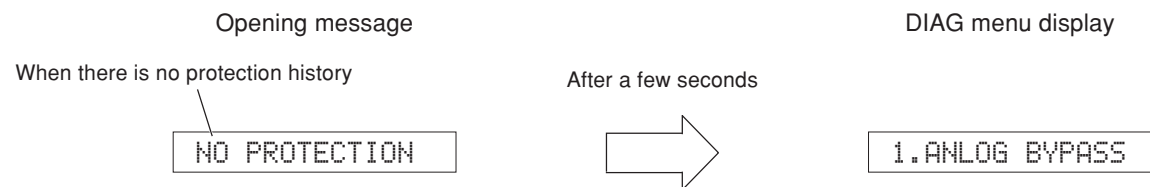

When there is a history of protection function:

When there is a history of protection function due to excess current

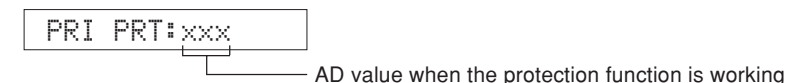

Cause: An excessive current flowed through the power amplifier.

Supplementary information:

As current of the power amplifier is detected, the abnormal channel can be identified by checking the current detect transistor. Turning on the power without correcting the abnormality will cause the protection function to work immediately and the power supply will instantly be shut off.

Note)

- Applying the power to the main unit without correcting the abnormality can be dangerous and cause additional circuit damage. To avoid this, if “PRI” and “PRD” protection function has been activated 3 times continuously, the power will not turn on even when the “STANDBY/ON” key is pressed. In order to turn on the power again, disconnect the power cable of the main unit from the AC outlet once and then reconnect it again.
- The output transistors in each amplifier channel should be checked for damage before applying power of the main unit.
- Amplifier current should be monitored by measuring across the emitter resistors for each channel.

When there is a history of protection function due to abnormal DC output

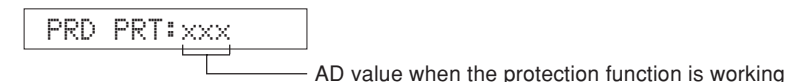

Cause: DC output of the power amplifier is abnormal.

Supplementary information:

The protection function worked due to a DC voltage appearing at the speaker terminal. A cause could be a defect in the amplifier. If the power is turned on with the abnormality unsolved, the protection function works in about 3 seconds to turn off the power.

When there is a history of protection function due to abnormal voltage in the power supply section

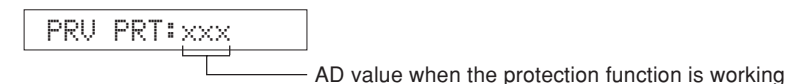

Cause: The voltage in the power supply section is abnormal.

Supplementary information:

The protection function worked due to a defect or overload in the power supply. If the power is turned on with the abnormality unsolved, the protection function works in about 1 second to turn off the power.

When there is a history of protection function due to excessive heat sink temperature

THM PRT: xxx

AD value when the protection function is working

Cause: The temperature of the heat sink is excessive.

Supplementary information:

The protection function worked due to the temperature limit being exceeded.

Causes could be poor ventilation or a defect related to the thermal sensor.

If the power is turned on with the abnormality unsolved, the protection function works in about 1 second to turn off the power.

For detection of each protection function, refer to DIAG menu described later.

History of protection function

When the protection function has worked, its history is stored in memory with a backup.

Even if no abnormality is noted while servicing the unit, an abnormality which has occurred previously can be defined as long as the backup data has been stored.

The history of the protection function is cleared when DIAG is canceled by selecting PRESET RESERVED (Memory initialized) of DIAG menu No. 8 or when the backup data is erased.

• Operation procedure of DIAG menu and Sub-menu

There are 18 menu items, each of having sub-menu items.

DIAG menu selection:

Select the menu using ">" (forward) and "<" (reverse) keys of PROGRAM.

Sub-menu selection:

Select the sub-menu using "SCENE 2" (forward) and "SCENE 1" (Reverse) keys.

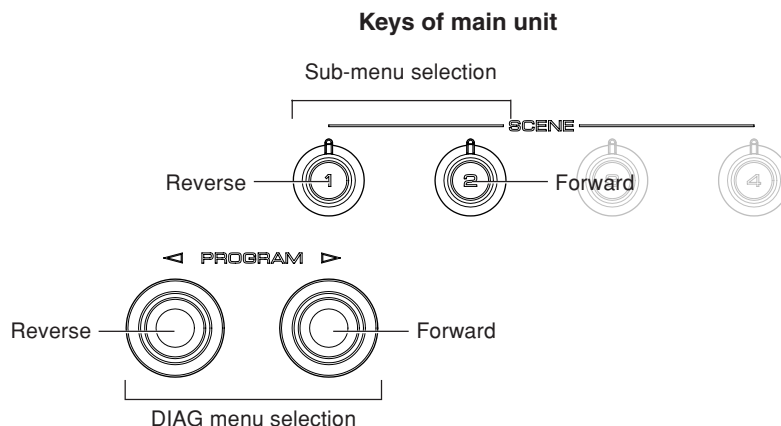

• Functions in DIAG mode

In addition to the DIAG menu items, functions as listed below are available.

- Power on/off
- Master volume
- Muting
- Speakers A/B/OFF
- Input selection
- Audio select
- Tone control

* Functions related to the tuner and the set menu are not available.

• Initial settings used to start DIAG

The following initial settings are used when starting DIAG.

When DIAG is canceled, these settings are restored to those before starting DIAG.

- Master volume: -20 dB
- Input: DVD (MULTI CHANNEL INPUT OFF)
- Effect level: 0 dB
- DIAG menu: 1. ANALOG BYPASS

• **Details of DIAG menu**

1. BYPASS

Using the sub-menu, it is possible to select ANALOG BYPASS output or DSP BYPASS output.

ANALOG BYPASS

The analog input sound signal is output to FRONT L/R with EFFECT OFF.

1. ANALOG BYPASS

INPUT: DVD ANALOG

SPEAKER OUT: 1 kHz, SUBWOOFER OUTPUT: 50 Hz

Input level	Volume	SPEAKER OUT			SUBWOOFER OUTPUT
		FRONT	CENTER	SURROUND	
Both ch, -20 dBm	+6.0 dB	+11.5 dBm	-∞	-∞	-∞

DSP BYPASS

The digital input sound signal is output to FRONT L/R with EFFECT OFF.

1. DSP BYPASS

INPUT: DVD ANALOG

SPEAKER OUT: 1 kHz, SUBWOOFER OUTPUT: 50 Hz

Input level	Volume	SPEAKER OUT			SUBWOOFER OUTPUT
		FRONT	CENTER	SURROUND	
Both ch, -20 dBm	+6.0 dB	+11.5 dBm	-∞	-∞	-∞

2. AUDIO CHECK

The input sound signal is output.

* When the inputted sound signal is 2 ch L/R, it is distributed as follows when output.

L ch: FRONT L, CENTER, SURROUND L,
LFE (L ch +10 dB)

R ch: SURROUND R

2. AUDIO CHECK

INPUT: DVD ANALOG

SPEAKER OUT: 1 kHz, SUBWOOFER OUTPUT: 50 Hz

Input level	Volume	SPEAKER OUT			SUBWOOFER OUTPUT
		FRONT	CENTER	SURROUND	
Both ch, -20 dBm	+6.0 dB	+11.5 dBm	+11.5 dBm	+11.5 dBm	0 dBm

RX-V461/HTR-6040/
RX-V461DAB

3. SPEAKER SET

The analog switch settings for each sub-menu are as shown in the table below.

FRONT : SML 0dB	SMALL	LARGE	LARGE	SWFR
CENTER : NONE	LARGE	NONE	LARGE	SWFR
LFE/B : FRNT	LARGE	SMALL	SMALL	FRONT
TONE : MAX	LARGE	LARGE	LARGE	SWFR
TONE : MIN	LARGE	LARGE	LARGE	SWFR

- LARGE:** This mode is used for a speaker with high bass reproduction performance (a large unit). Full bandwidth signals are output.
- SMALL:** This mode is used for a speaker with low bass reproduction performance (a small unit). The signals of 90 Hz or less are mixed into the channel specified by LFE/BASS.
- NONE:** This mode is used for no center speaker. The center content is reduced by 3 dB and distributed to FRONT L/R.
- SWFR:** LFE of 5.1 ch signal or LFE/BASS lower than 90 Hz is output through SUBWOOFER OUT.
- FRONT:** LFE of 5.1 ch signal or LFE/BASS lower than 90 Hz is distributed to FRONT L/R.

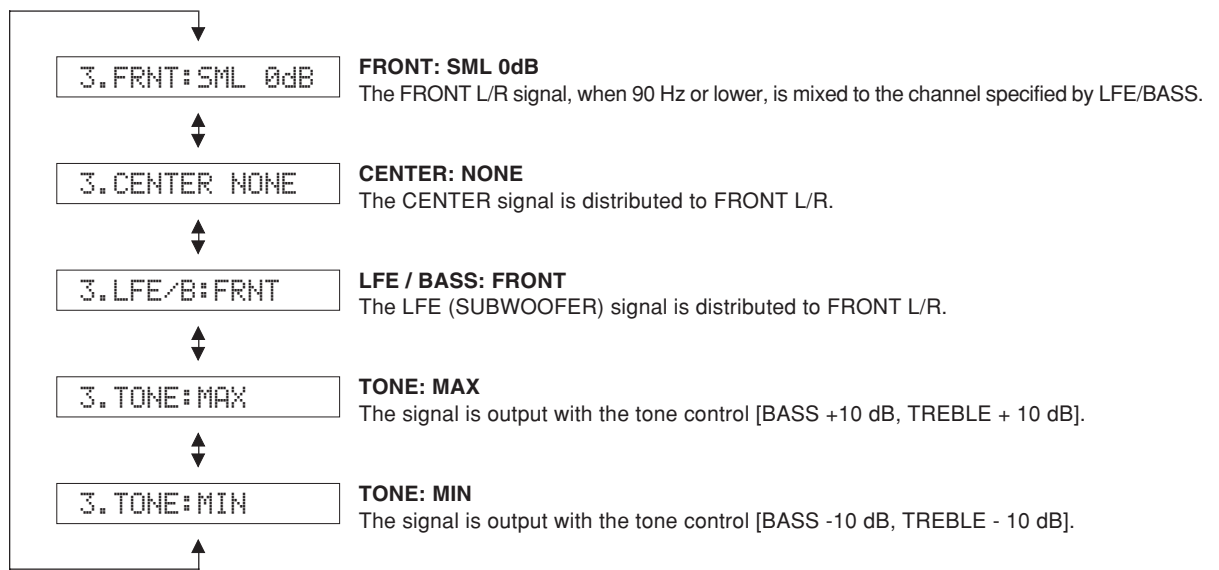

INPUT: DVD ANALOG

SPEAKER OUT: 1 kHz, SUBWOOFER OUTPUT: 50 Hz

Sub-menu	Input level	Volume	SPEAKER OUT			SUBWOOFER OUTPUT
			FRONT	CENTER	SURROUND	
FRONT : SML 0dB	Both ch, -20 dBm	+6.0 dB	+11.5 dBm	-∞	-∞	-3.5 dBm
CENTER : NONE	Both ch, -20 dBm	+6.0 dB	+11.5 dBm	-∞	-∞	-∞
LFE/B : FRNT	Both ch, -20 dBm	+6.0 dB	+11.5 dBm	-∞	-∞	-∞
TONE : MAX	Both ch, -20 dBm	+6.0 dB	+14.5 dBm	-∞	-∞	-∞
TONE : MIN	Both ch, -20 dBm	+6.0 dB	+8.5 dBm	-∞	-∞	-∞

4. 6CH INPUT

The input source [MULTI CHANNEL INPUT] is selected.
It is possible to select the 6-ohm/8-ohm by using the sub-menu.

6 ch INPUT 6-ohm

4.6ch INPUT 6Ω

INPUT: MULTI CH INPUT
SPEAKER OUT: 1 kHz, SUBWOOFER OUTPUT: 50 Hz

Sub-menu	Input level	Volume	SPEAKER OUT			SUBWOOFER OUTPUT
			FRONT	CENTER	SURROUND	
6 ch INPUT 6-ohm	Both ch, -20 dBm	+6.0 dB	+11.5 dBm	+11.5 dBm	+11.5 dBm	-3.5 dBm

6 ch INPUT 8-ohm

4.6ch INPUT 8Ω

INPUT: MULTI CH INPUT
SPEAKER OUT: 1 kHz, SUBWOOFER OUTPUT: 50 Hz

Sub-menu	Input level	Volume	SPEAKER OUT			SUBWOOFER OUTPUT
			FRONT	CENTER	SURROUND	
6 ch INPUT 8-ohm	Both ch, -20 dBm	+6.0 dB	+11.5 dBm	+11.5 dBm	+11.5 dBm	-3.5 dBm

LIM/PLDET/THM

- LIM:** Setting value of LIM (Limiter control)
* As this is a development menu, do not change the setting value.
- PLDET:** Power limiter detection
The A/D conversion value during operation is displayed.
- THM:** Thermo protection detection
The A/D conversion value during operation is displayed.
(Reference voltage: 3.3 V=255)

4.255:255: 69

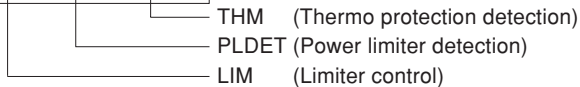

5. MIC CHECK

The signals input through the microphone are output of FRONT L/R via A/D and D/A.

5.MIC CHECK

7. TEST TONE

The noise generator with a built-in microprocessor outputs the noise through the channels specified by the submenu. The noise frequency for LFE (SUBWOOFER) is 35 to 80 Hz. Other than that, the noise frequency is 500 to 2 kHz.

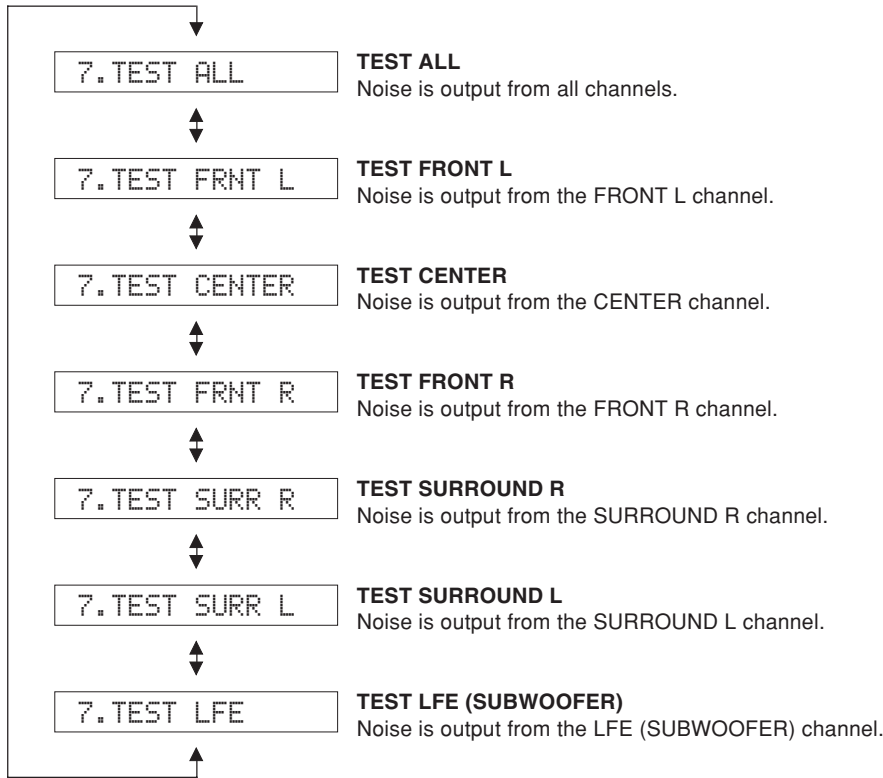

8. FACTORY PRESET

This menu is used to reserve and inhibit initialization of the back-up RAM. The signals are processed using EFFECT OFF (The L/R signal is output using ANALOG BYPASS).

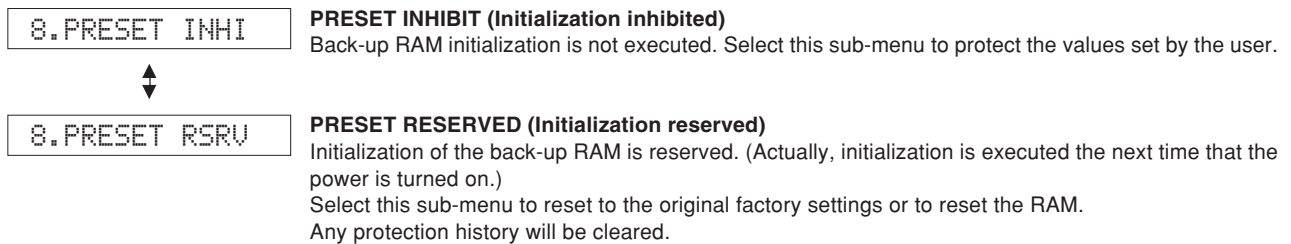

CAUTION: Before setting to the PRESET RESERVED, write down the existing preset memory content of the tuner in a table as shown below.
(This is because setting to the PRESET RESERVED will cause the user memory content of the tuner to be erased.)

Preset Group	P1	P2	P3	P4	P5	P6	P7	P8
A								
B								
C								
D								
E								

RX-V461/HTR-6040/
RX-V461DAB

9. A/D DATA CHECK

This menu is used to display the A/D conversion value of the microprocessor which detects panel keys of the main unit and protection functions in using the sub-menu.

When K0/K1 menu is selected, keys become non-operable due to detection of the values of all keys. However, it is possible to advance to the next sub-menu by turning the VOLUME of the main unit. When using this function, note that turning the VOLUME more than 1 click would cause the volume value to change.

During signal processing, the condition before execution is maintained.

* The figures in the diagram are given as reference only.

PD/PV

PD: PRD (Power amplifier DC protection detection)
The output of power amplifier DC (DC voltage) is detected.

Normal value: 35 to 81 (Reference voltage: 3.3 V=255)

PV: PRV (Voltage protection detection)

Voltage detects: ACL, AC2, 10V, S9, +12, -12, +5V and VP

Normal value: 84 to 153 (Reference voltage: 3.3 V=255)

* If PRD and PRV are out of the normal value range, the protection function works to turn off the power.

PD: 58 PV:119

TH/PL

TH: THM (Thermo protection detection)

The temperature of the heat sink is detected.
Normal value: 0 to 124 (Reference voltage: 3.3 V=255)

* If THM is out of the normal value range, the protection function works to turn off the power.

PL: PLDET (Power limiter detection)

The output voltage of power amplifier is detected.

TH: 69 PL:255

Reference voltage: 3.3 V=255

	During normal operation	Value for starting limiter operation	Value for canceling limiter operation
PLDET	255	100	131
LIM H: 255 / L: 90	H	L	H

(LIM: Limiter control)

PI/DE

PI: PRI (Current protection detection)
The current of the power amplifier is detected.

Normal value: 0 to 100 (Reference voltage: 3.3 V=255)

DE: PDET (Sub-trans power detection)

Normal value: 209 to 255 (Reference voltage: 3.3 V=255)

* If PRI and PDET are out of the normal value range, the protection function works to turn off the power.

PI: 6 DE:255

K0/K1

K0/K1: KEY0/KEY1 (Panel key of main unit)
A/D value of the key fails to function properly when the standard value is deviated by ± 4 . In this case, check the constant of partial pressure resistor, solder condition, etc. Refer to table.

(Reference voltage: 3.3 V=255)

K0:254 K1:255

Display	KEY0	KEY1
23 \pm 4	SCENE 1	SCENE 3
42 \pm 4	SCENE 2	SCENE 4
66 \pm 4	PROGRAM <	DIRECT
92 \pm 4	PROGRAM >	AUDIO SELECT
120 \pm 4	STRAIGHT	INPUT <
147 \pm 4	TONE CONTROL	INPUT >
165 \pm 4	SEARCH MODE	PRESET/TUNING <
182 \pm 4	FM/AM	PRESET/TUNING >
198 \pm 4	A/B/C/D/E	MEMORY
217 \pm 4	SPEAKERS	TUNING
255	(KEY OFF)	(KEY OFF)

10. XM STATUS

Not applied to these models.

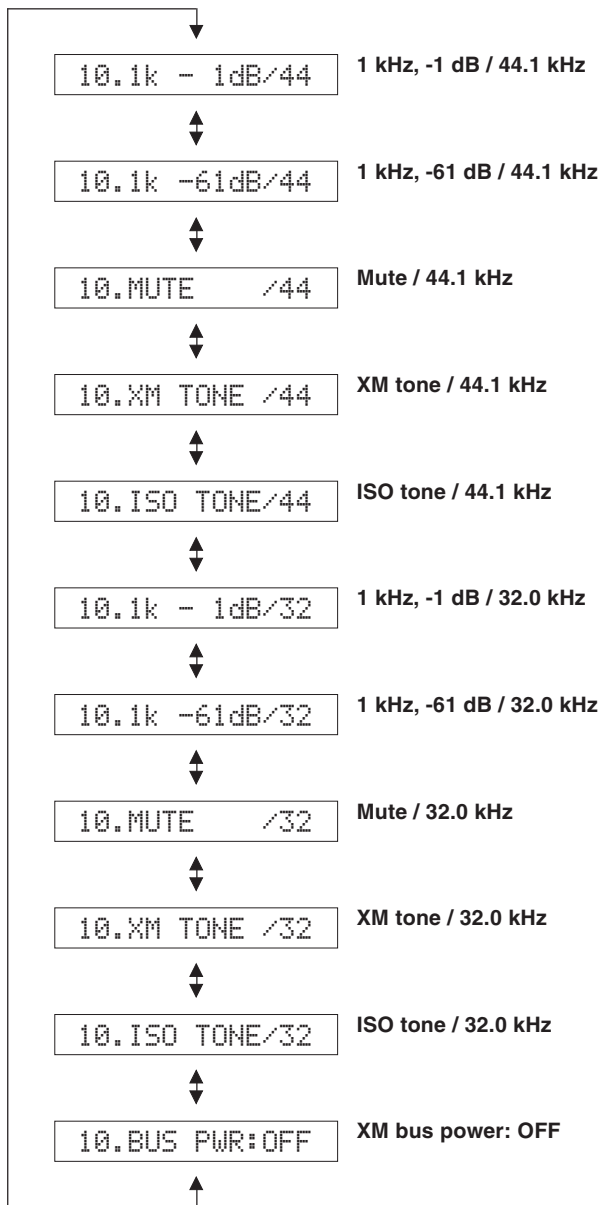

11. DOCK (B model)

This menu is used to test the DOCK connector without the iPod itself.

After turning off the power, short between pins No. 14 (TX) and No. 18 (RX), between pins No. 1 (PWR) and No. 17 (ACCPOW) and between pins No. 4 (iPDET) and No. 8 (DGND).

Start the DIAG function and select the menu.

The check result is displayed according to the following display specifications.

Note) Be sure to return the shorted locations to their original state.

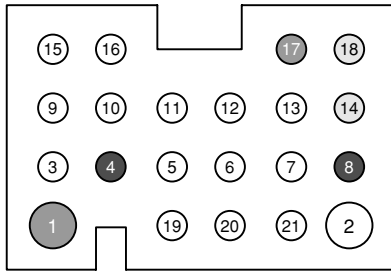

DOCK

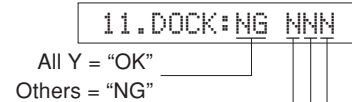

Check item	Result	Display
UART loop back test	OK	Y
	NG	N
iPAP (iPod accessory power) detection	IC402 pin No. 1 High	Y
	IC402 pin No. 1 Low	N
iPDET (iPod installation to DOCK) detection	IC402 pin No. 12 Low	Y
	IC402 pin No. 12 High	N

DOCK ignore

When DOCK and iPod are connected, the input source [DOCK (iPod)] is made invalid and [V-AUX] is selected.



12. USB CHECK

The music file recorded in the USB flash memory is reproduced.

- The music file is copied into the root folder of the USB flash memory.
- Insert the USB flash memory to the USB terminal of the main unit.

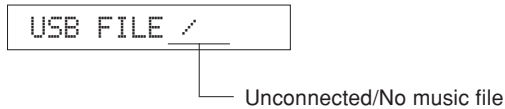

USB FILE1

The first piece of the music file is reproduced.

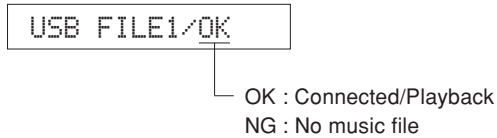

USB FILE2

The second piece of the music file is reproduced.

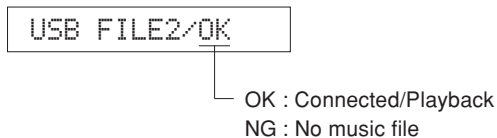

13. DAB CHECK (B model)

Using the DIAG menu, it is possible to select DAB SCAN, DLS, SIGNAL QUALITY.

DAB SCAN/SCL

The channel that can be received is searched. When reception is completed the SCL (Service Label) is displayed.

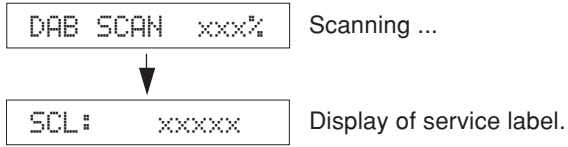

DLS (Dynamic Label Segment)

DLS (Dynamic Label Segment) of the channel being received is displayed.

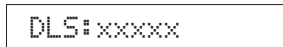

SIGNAL QUALITY

The reception level of the channel being received is displayed.

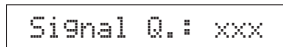

14. IF STATUS (Input function status)

Not applied to these models.



15. PROTECTION SETTING

The A/D setting value of each protection is displayed.

(Reference voltage: 3.3 V=255)

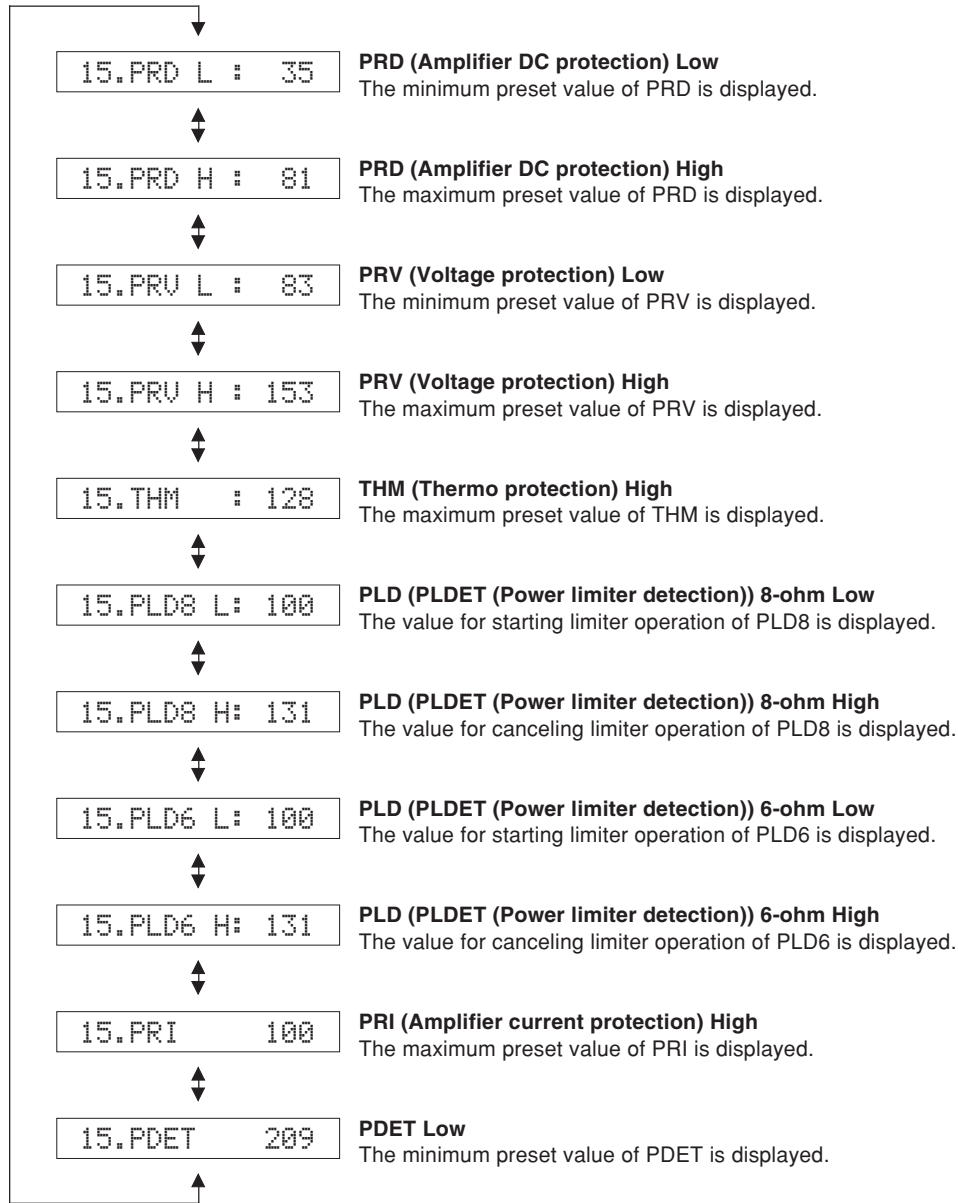

16. PROTECTION HISTORY

Four protection histories are displayed.

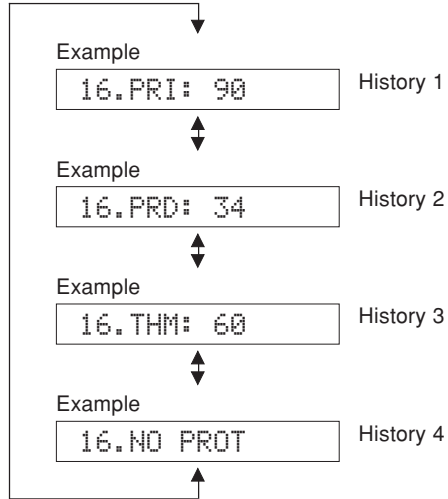

17. SOFT SWITCH

Note) As this is a development menu, do not change the function setting. Changing the function setting may hinder the proper operation.

This menu is used to switch the function settings on P.C.B. through the software to activate the main unit. The protection function follows the P.C.B. settings.

* As this is a development menu, it is not possible to describe the details.

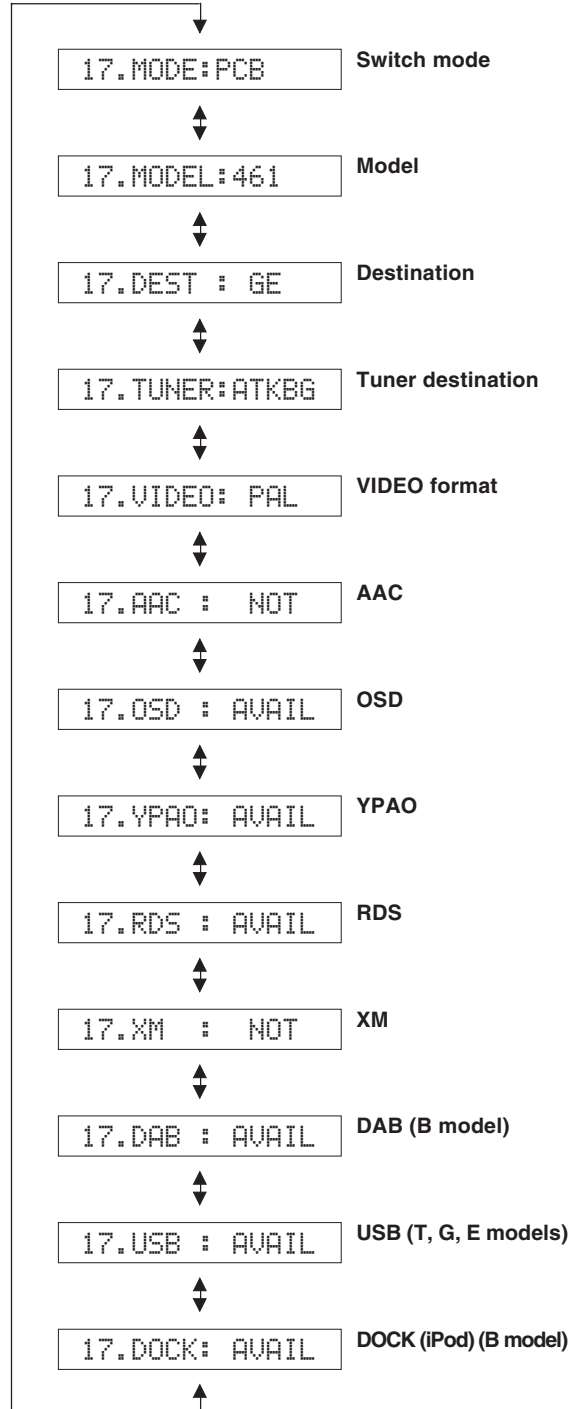

■ DISPLAY DATA

● V2001 : 17-BT-29GNK (OPERATION P.C.B.)

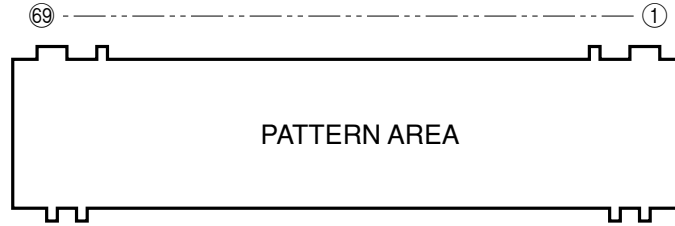

● PIN CONNECTION

Pin No.	69	68	67	66	65	64	63	62	61	60	59	58	57	56	55	54	53	52	51	50	49	48	47	46	45	44	43	42	41	40	39	38	37	36	35
Connection	F2	NX	NP	NP	P1	P2	P3	P4	P5	P6	P7	P8	P9	P10	P11	P12	P13	P14	P15	P16	P17	P18	P19	P20	P21	P22	P23	P24	P25	P26	P27	P28	P29	P30	P31

Pin No.	34	33	32	31	30	29	28	27	26	25	24	23	22	21	20	19	18	17	16	15	14	13	12	11	10	9	8	7	6	5	4	3	2	1
Connection	P32	P33	P34	P35	P36	P37	NX	NX	NX	NX	NX	NX	NX	17G	16G	15G	14G	13G	12G	11G	10G	9G	8G	7G	6G	5G	4G	3G	2G	1G	NP	NP	NX	F1

Note : 1) F1, F2 Filament pin 2) NP No pin 3) NX No extend pin 4) 1G~17G Grid pin

● GRID ASSIGNMENT

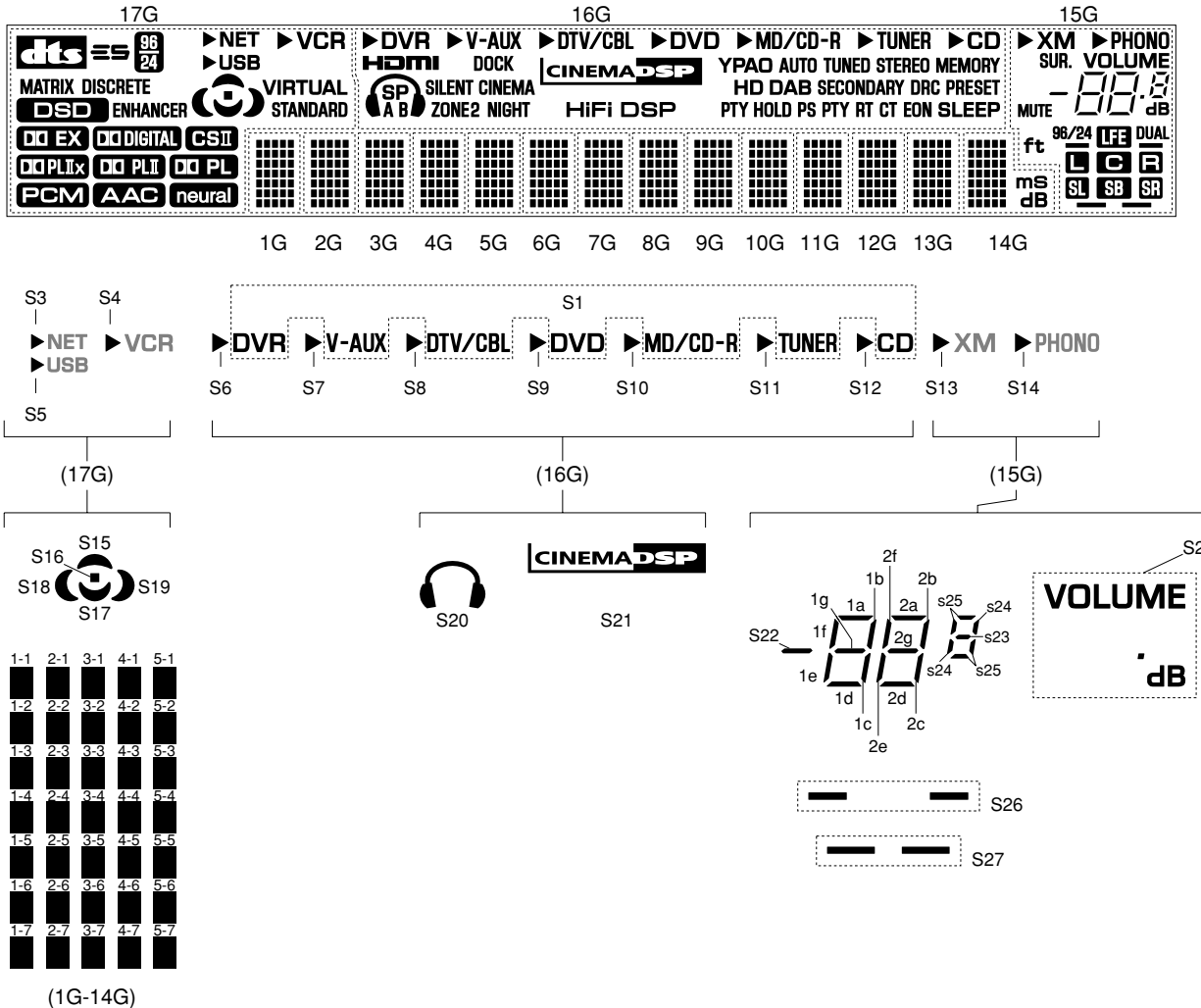

RX-V461/HTR-6040/RX-V461DAB

● ANODE CONNECTION

	17G	16G	15G	14G	13G-1G
1P	dtb	S1	S2	1-1	1-1
2P	ES	S6	S26	2-1	2-1
3P	MATRIX	S7	S27	3-1	3-1
4P	DISCRETE	S8	S22	4-1	4-1
5P	96 24	S9	1a	5-1	5-1
6P	DSD	S10	1b	1-2	1-2
7P	ENHANCER	S11	1c	2-2	2-2
8P	DD EX	S12	1d	3-2	3-2
9P	DD DIGITAL	HDMI	1e	4-2	4-2
10P	CSII	S20	1f	5-2	5-2
11P	DD PLIX	SP	1g	1-3	1-3
12P	DD PLI	A	2a	2-3	2-3
13P	DD PL	B	2b	3-3	3-3
14P	PCM	SILENT CINEMA	2c	4-3	4-3
15P	AAC	ZONE2	2d	5-3	5-3
16P	neural	NIGHT	2e	1-4	1-4
17P	NET	DOCK	2f	2-4	2-4
18P	USB	S21	2g	3-4	3-4
19P	VCR	HiFi DSP	S23	4-4	4-4
20P	S3	YPAO	S24	5-4	5-4
21P	S5	AUTO	S25	1-5	1-5
22P	S4	TUNED	XM	2-5	2-5
23P	S15	STEREO	PHONO	3-5	3-5
24P	S16	MEMORY	S13	4-5	4-5
25P	S17	HD	S14	5-5	5-5
26P	S18	DAB	SUR.	1-6	1-6
27P	S19	SECONDARY	MUTE	2-6	2-6
28P	VIRTUAL	DRC	DUAL	3-6	3-6
29P	STANDARD	PRESET	96/24	4-6	4-6
30P	–	PTY (HOLD)	ft	5-6	5-6
31P	–	HOLD	LFE	1-7	1-7
32P	–	PS	L	2-7	2-7
33P	–	PTY	C	3-7	3-7
34P	–	RT	R	4-7	4-7
35P	–	CT	SL	5-7	5-7
36P	–	EON	SB	ms	–
37P	–	SLEEP	SR	dB	–

IC DATA

IC101: ADSP-BF531 CPU (DSP P.C.B.)
Microprocessor with DSP

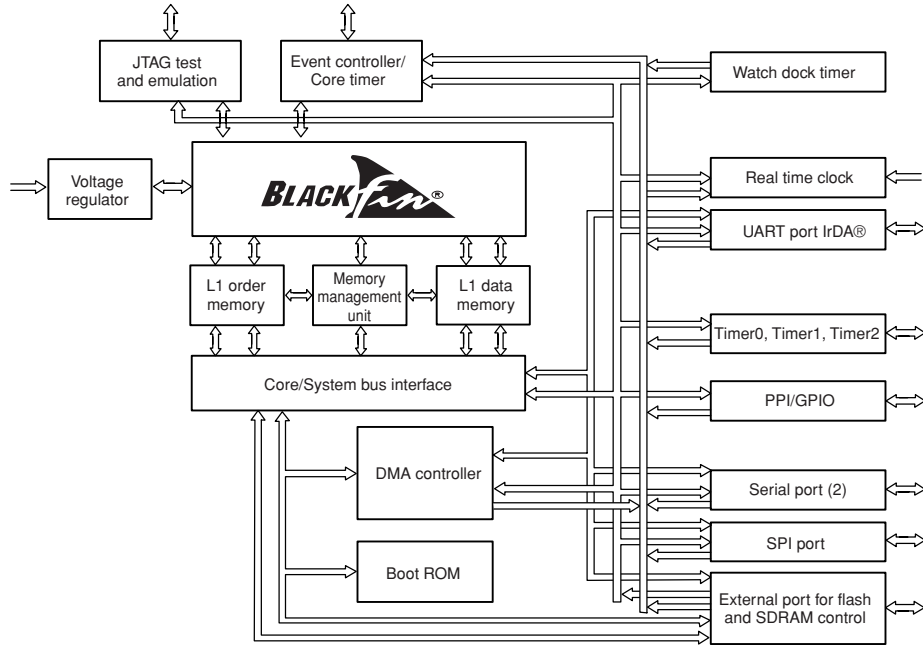

176	GND	132	GND
175	GND	131	GND
174	GND	130	GND
173	SCKE	129	GND
172	FSMS	128	GND
171	VDDEXT	127	ADDR13
169	CLKOUT	126	ADDR14
168	VDDINT	125	ADDR15
167	SRAS	124	ADDR16
166	SCAS	123	ADDR17
165	SWE	122	ADDR18
164	SA10	121	ADDR19
163	BR	120	BGH
162	ABDY	119	BG
161	AMSD	118	VDDEXT
160	AMS1	117	GND
159	AMS2	116	DATA0
158	AMS3	115	DATA1
157	VDDINT	114	DATA2
156	VDDEXT	113	DATA3
155	GND	112	DATA4
154	ADE	111	VDDINT
153	ARE	110	DATA5
152	AWE	109	DATA6
151	ABE0	108	DATA7
150	ABE1	107	VDDEXT
149	ADDR1	106	GND
148	ADDR2	105	DATA8
147	ADDR3	104	DATA9
146	ADDR4	103	DATA10
145	VDDEXT	102	DATA11
144	GND	101	DATA12
143	VDDINT	100	DATA13
142	ADDR5	99	DATA14
141	ADDR6	98	DATA15
140	ADDR7	97	GND
139	ADDR8	96	BMODE0
138	ADDR9	95	BMODE1
137	ADDR10	94	TCK
136	ADDR11	93	VDDEXT
135	ADDR12	92	GND
134	VDDEXT	91	GND
133	GND	90	GND
		89	GND

176	GND	45	VDDEXT
175	GND	46	PF5
174	GND	47	PF4
173	SCKE	48	PF3
172	FSMS	49	PF2
171	VDDEXT	50	PF1
169	CLKOUT	51	PF0
168	VDDINT	52	VDDINT
167	SRAS	53	SCK
166	SCAS	54	MISO
165	SWE	55	MOSI
164	SA10	56	GND
163	BR	57	VDDEXT
162	ABDY	58	DT1SEC
161	AMSD	59	DT1PRI
160	AMS1	60	TFS1
159	AMS2	61	TSCLK1
158	AMS3	62	DR1SEC
157	VDDINT	63	DR1PRI
156	VDDEXT	64	RFS1
155	GND	65	RSCLK1
154	ADE	66	VDDINT
153	ARE	67	DT0SEC
152	AWE	68	DT0PRI
151	ABE0	69	TFS0
150	ABE1	70	GND
149	ADDR1	71	VDDEXT
148	ADDR2	72	TSCLK0
147	ADDR3	73	DR0SEC
146	ADDR4	74	DR0PRI
145	VDDEXT	75	RFS0
144	GND	76	RSCLK0
143	VDDINT	77	TMR2
142	ADDR5	78	TMR1
141	ADDR6	79	TMR0
140	ADDR7	80	VDDINT
139	ADDR8	81	TX
138	ADDR9	82	RX
137	ADDR10	83	EMU
136	ADDR11	84	TRST
135	ADDR12	85	TMS
134	VDDEXT	86	TDI
133	GND	87	TDO
		88	GND

ADSP-BF531

IC101

Core Clock = 25M * 16 / 1
= 400 MHz (Max : 400M)

System Clock = 25M * 16 / 3
= 133 MHz (Max : 133M)

RX-V461/HTR-6040/
RX-V461DAB

Pin No.	Port Name	Function Name	I/O	Detail of Function
1	GND	DGND	–	Ground of external
2	GND	DGND	–	Ground of external
3	GND	DGND	–	Ground of external
4	VROUT2	/VINTSW	O	Voltage regulator drive for Q101
5	VROUT1	/VINTSW	O	Voltage regulator drive for Q101
6	VDDEXT	VDDEXT	–	I/O power supply (EX3.3)
7	GND	DGND	–	Ground of external
8	GND	DGND	–	Ground of external
9	GND	DGND	–	Ground of external
10	CLKIN	CLKIN	I	Clock/oscillation input
11	XTAL	XTAL	O	Oscillation output
12	VDDEXT	VDDEXT	–	I/O power supply (EX3.3)
13	/RESET	/DRESET	I	Delayed reset
14	NMI	NMI/DGND	I	(Pull-down)
15	GND	DGND	–	Ground of external
16	RTXO	–	O	
17	RTXI	RTXI/DGND	I	(Pull-down)
18	VDDRTC	–	–	
19	GND	DGND	–	Ground of external
20	VDDEXT	VDDEXT	–	I/O power supply (EX3.3)
21	PPI_CLK	–	I	
22	PP10	–	I/O	
23	PP11	–	I/O	
24	PP12	–	I/O	
25	VDDINT	VDDINT	–	Power supply of microprocessor (BF1.2)
26	PP13	–	I/O	
27	PF15	USB_DREQ1/SDT_DAB	I/O	DMA request from USB (T, G, E models) / I2C data for DAB (B model)
28	PF14	USB_INT/SCK_DAB	I/O	Interrupt from USB (T, G, E models) / I2C clock for DAB (B model)
29	PF13	RDDA	I	RDS data (B, G, E models)
30	GND	DGND	–	Ground of external
31	VDDEXT	VDDEXT	–	I/O power supply (EX3.3)
32	PF12	RDS_RDY	O	RDS ready (B, G, E models)
33	PF11	RDCL	O	RDS clock (B, G, E models)
34	PF10	INTAK	I	CODEC IC (IC301) interrupt
35	PF9	FSYNC/TFS0	I	Frame sync detect
36	PF8	R2A_DATA	I	DATA for R2A volume/selector IC (IC162)
37	PF7	R2A_CLK	O	CLK for R2A volume/selector IC (IC161)
38	PF6	VRB	I	Volume rotary B
39	GND	DGND	–	Ground of external
40	GND	DGND	–	Ground of external
41	GND	DGND	–	Ground of external
42	GND	DGND	–	Ground of external
43	GND	DGND	–	Ground of external
44	GND	DGND	–	Ground of external
45	VDDEXT	VDDEXT	–	I/O power supply (EX3.3)
46	PF5	VRA	I	Volume rotary A
47	PF4	REM	I	IR remote control pulse input
48	PF3	PSW	I	Power switch (STANDBY/ON)
49	PF2	/SPISEL2	O	CS for EEPROM (IC102)
50	PF1	/SPISEL1	O	CS for 4 ch ADC (IC401)
51	PF0	/EXPE	O	Extended port enable
52	VDDINT	VDDINT	–	Power supply of microprocessor (BF1.2)
53	SCK	SPISCK	O	SPI clock
54	MISO	SPIMI	I	Master input/slave output
55	MOSI	SPIMO	O	Master output/slave input
56	GND	DGND	–	Ground of external
57	VDDEXT	VDDEXT	–	I/O power supply (EX3.3)
58	DT1SEC	DT1SEC	O	Serial port 1, secondary transmission data
59	DT1PRI	DT1PRI	O	Serial port 1, primary transmission data
60	TFS1	TFS1	I	Serial port 1, frame asynchronous transmission

Pin No.	Port Name	Function Name	I/O	Detail of Function
61	TSCLK1	TSCLK1	I	Serial port 1, serial transmission clock
62	DR1SEC	DR1SEC	I	Serial port 1, secondary reception data
63	DR1PRI	DR1PRI	I	Serial port 1, primary reception data
64	RFS1	RFS1	I	Serial port 1, frame synchronization reception
65	RSCLK1	RSCLK1	I	Serial port 1, serial reception clock
66	VDDINT	VDDINT	-	Power supply of microprocessor (BF1.2)
67	DT0SEC	DT0SEC	O	Serial port 0, secondary transmission data
68	DT0PRI	DT0PRI	O	Serial port 0, primary transmission data
69	TFS0	TFS0	I	Serial port 0, frame asynchronous transmission
70	GND	DGND	-	Ground of external
71	VDDEXT	VDDEXT	-	I/O power supply (EX3.3)
72	TSCLK0	TSCLK0	I	Serial port 0, serial transmission clock
73	DR0SEC	DR0SEC	I	Serial port 0, secondary reception data
74	DR0PRI	DR0PRI	I	Serial port 0, primary reception data
75	RFS0	RFS0	I	Serial port 0, frame synchronization reception
76	RSCLK0	RSCLK0	I	Serial port 0, serial reception clock
77	TMR2	-	I/O	
78	TMR1	-	I/O	
79	TMR0	LIMITER	O	Limiter control output
80	VDDINT	VDDINT	-	Power supply of microprocessor (BF1.2)
81	TX	TxDi	O	UART transmission for DOCK (iPod) (B model)
82	RX	RxDi	I	UART reception for DOCK (iPod) (B model)
83	/EMU	-	O	
84	/TRST	-	I	
85	TMS	-	I	
86	TDI	-	I	
87	TDO	-	O	
88	GND	DGND	-	Ground of external
89	GND	DGND	-	Ground of external
90	GND	DGND	-	Ground of external
91	GND	DGND	-	Ground of external
92	GND	DGND	-	Ground of external
93	VDDEXT	VDDEXT	-	I/O power supply (EX3.3)
94	TCK	-	I	
95	BMODE1	BMODE1	I	(Pull-down)
96	BMODE0	BMODE0	I	(Pull-up)
97	GND	DGND	-	Ground of external
98	DATA15	D16	I/O	SDRAM data bus 16
99	DATA14	D15	I/O	SDRAM data bus 15
100	DATA13	D14	I/O	SDRAM data bus 14
101	DATA12	D13	I/O	SDRAM data bus 13
102	DATA11	D12	I/O	SDRAM data bus 12
103	DATA10	D11	I/O	SDRAM data bus 11
104	DATA9	D09	I/O	SDRAM data bus 09
105	DATA8	D08	I/O	SDRAM data bus 08
106	GND	DGND	-	Ground of external
107	VDDEXT	VDDEXT	-	I/O power supply (EX3.3)
108	DATA7	D07	I/O	SDRAM data bus 07
109	DATA6	D06	I/O	SDRAM data bus 06
110	DATA5	D05	I/O	SDRAM data bus 05
111	VDDINT	VDDINT	-	Power supply of microprocessor (BF1.2)
112	DATA4	D04	I/O	SDRAM data bus 04
113	DATA3	D03	I/O	SDRAM data bus 03
114	DATA2	D02	I/O	SDRAM data bus 02
115	DATA1	D01	I/O	SDRAM data bus 01
116	DATA0	D00	I/O	SDRAM data bus 00
117	GND	DGND	-	Ground of external
118	VDDEXT	VDDEXT	-	I/O power supply (EX3.3)
119	/BG	-	O	
120	/BGH	-	O	

RX-V461/HTR-6040/
RX-V461DAB

Pin No.	Port Name	Function Name	I/O	Detail of Function
121	ADDR19	A19	O	SDRAM address bus 19
122	ADDR18	A18	O	SDRAM address bus 18
123	ADDR17	A17	O	SDRAM address bus 17
124	ADDR16	A16	O	SDRAM address bus 16
125	ADDR15	A15	O	SDRAM address bus 15
126	ADDR14	A14	O	SDRAM address bus 14
127	ADDR13	A13	O	SDRAM address bus 13
128	GND	DGND	-	Ground of external
129	GND	DGND	-	Ground of external
130	GND	DGND	-	Ground of external
131	GND	DGND	-	Ground of external
132	GND	DGND	-	Ground of external
133	GND	DGND	-	Ground of external
134	VDDEXT	VDDEXT	-	I/O power supply (EX3.3)
135	ADDR12	A12	O	SDRAM address bus 12
136	ADDR11	A11	O	SDRAM address bus 11
137	ADDR10	A10	O	SDRAM address bus 10
138	ADDR9	A09	O	SDRAM address bus 09
139	ADDR8	A08	O	SDRAM address bus 08
140	ADDR7	A07	O	SDRAM address bus 07
141	ADDR6	A06	O	SDRAM address bus 06
142	ADDR5	A05	O	SDRAM address bus 05
143	VDDINT	VDDINT	-	Power supply of microprocessor (BF1.2)
144	GND	DGND	-	Ground of external
145	VDDEXT	VDDEXT	-	I/O power supply (EX3.3)
146	ADDR4	A04	O	SDRAM address bus 04
147	ADDR3	A03	O	SDRAM address bus 03
148	ADDR2	A02	O	SDRAM address bus 02
149	ADDR1	A01	O	SDRAM address bus 01
150	/ABE1	SDQM1	O	SDRAM byte enable/data mask 1
151	/ABE0	SDQM0	O	SDRAM byte enable/data mask 0
152	/AWE	/AWE	O	Write enable (Asynchronous)
153	/ARE	/ARE	O	Read enable
154	/AOE	/AOE	O	Output enable
155	GND	DGND	-	Ground of external
156	VDDEXT	VDDEXT	-	I/O power supply (EX3.3)
157	VDDINT	VDDINT	-	Power supply of microprocessor (BF1.2)
158	/AMS3	/AMS3	O	Bank select 3
159	/AMS2	/AMS2	O	Bank select 2
160	/AMS1	/AMS1	O	Bank select 1
161	/AMS0	/AMS0	O	Bank select 0
162	ARDY	ARDY	I	Hardware ready control
163	/BR	/BR	I	(Pull-up)
164	SA10	SA10	O	A10 pin
165	/SWE	/SWE	O	Write enable (Synchronization)
166	/SCAS	/SCAS	O	Sequence address strobe
167	/SRAS	/SRAS	O	Line address strobe
168	VDDINT	VDDINT	-	Power supply of microprocessor (BF1.2)
169	CLKOUT	CLKOUT	O	Clock output
170	GND	DGND	-	Ground of external
171	VDDEXT	VDDEXT	-	I/O power supply (EX3.3)
172	/SMS	/SMS	O	Bank select
173	SCKE	SCKE	O	Clock enable
174	GND	DGND	-	Ground of external
175	GND	DGND	-	Ground of external
176	GND	DGND	-	Ground of external

• **Microprocessor extended port**

IC204-IC207: SN74LV573APWR (DSP P.C.B.)
Octal 3-state D-latches with 3-state outputs

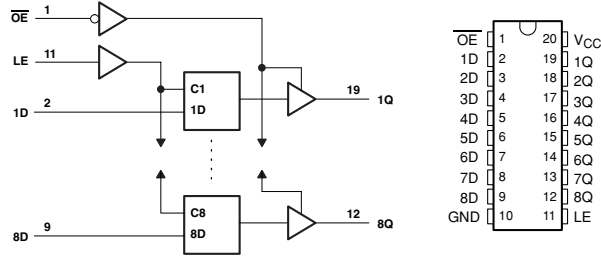

IC204

Pin No.	Port Name	Function Name	Detail of Function
1	/OE	/EXPE	Extended port enable
2	1D	D00	Data bus 00
3	2D	D01	Data bus 01
4	3D	D02	Data bus 02
5	4D	D03	Data bus 03
6	5D	D04	Data bus 04
7	6D	D05	Data bus 05
8	7D	D06	Data bus 06
9	8D	D07	Data bus 07
10	GND	DGND	Ground of external
11	LE	LEEX1	Bank select 1
12	8Q	/SPISEL3	CS for CODEC IC (IC301, DSP P.C.B.)
13	7Q	ADSEL2	4ch ADC input select 2
14	6Q	ADSEL1	4ch ADC input select 1
15	5Q	ADSEL0	4ch ADC input select 0
16	4Q	/CCBE	SPI bus switch
17	3Q	/CMT	Center mute
18	2Q	/SMT	Surround mute
19	1Q	/FMT	Front mute
20	VCC	EX3.3	Power supply

IC205

Pin No.	Port Name	Function Name	Detail of Function
1	/OE	/EXPE	Extended port enable
2	1D	D08	Data bus 08
3	2D	D09	Data bus 09
4	3D	D10	Data bus 10
5	4D	D11	Data bus 11
6	5D	D12	Data bus 12
7	6D	D13	Data bus 13
8	7D	D14	Data bus 14
9	8D	D15	Data bus 15
10	GND	DGND	Ground of external
11	LE	LEEX1	Bank select 1
12	8Q	Ex1-15/RDS_RST	RDS reset (B, G, E models)
13	7Q	SSEL3	SCENE select LED switch 3
14	6Q	SSEL2	SCENE select LED switch 2
15	5Q	SSEL1	SCENE select LED switch 1
16	4Q	/IC_AK	IC for CODEC IC (IC301, DSP P.C.B.), VFD (IC201, OPERATION P.C.B.) and USB (IC601, DSP P.C.B.) (T, G, E models)
17	3Q	/SPISEL4	CS for VFD (IC201, OPERATION P.C.B.)
18	2Q	/3.3SW	+3.3S switch
19	1Q	PRY	Power relay
20	VCC	EX3.3	Power supply

RX-V461/HTR-6040/
RX-V461DAB

IC206

Pin No.	Port Name	Function Name	Detail of Function
1	/OE	/EXPE	Extended port enable
2	1D	D00	Data bus 00
3	2D	D01	Data bus 01
4	3D	D02	Data bus 02
5	4D	D03	Data bus 03
6	5D	D04	Data bus 04
7	6D	D05	Data bus 05
8	7D	D06	Data bus 06
9	8D	D07	Data bus 07
10	GND	DGND	Ground of external
11	LE	LEEX2	Bank select 2
12	8Q	/VR1	Video select R
13	7Q	SPISEL5	CE for tuner
14	6Q	/8ohmSW	AC H/L relay (RY106, MAIN P.C.B.)
15	5Q	HPRY	Headphone relay (RY102, MAIN P.C.B.)
16	4Q	MRYA	Main speakers A relay (RY101, MAIN P.C.B.)
17	3Q	MRYB	Main speakers B relay (RY102, MAIN P.C.B.)
18	2Q	CSRY	Center/surround speakers relay (RY103/R Y105, MAIN P.C.B.)
19	1Q	/SWMT	Subwoofer mute
20	VCC	EX3.3	Power supply

IC207

Pin No.	Port Name	Function Name	Detail of Function
1	/OE	/EXPE	Extended port enable
2	1D	D08	Data bus 08
3	2D	D09	Data bus 09
4	3D	D10	Data bus 10
5	4D	D11	Data bus 11
6	5D	D12	Data bus 12
7	6D	D13	Data bus 13
8	7D	D14	Data bus 14
9	8D	D15	Data bus 15
10	GND	DGND	Ground of external
11	LE	LEEX2	Bank select 2
12	8Q	DST	Direct stereo
13	7Q	/OSDSEL	OSD/Video select
14	6Q	MON	Monitor mute
15	5Q	/SPISEL6	CS for OSD (IC342, VIDEO P.C.B.)
16	4Q	VIC	Video select C
17	3Q	Ex2-10/USB_N_DACK1	DMA ACK for USB (IC601, DSP P.C.B.) (T, G, E models)
18	2Q	Ex2-09/VIB	Video select B
19	1Q	Ex2-08/VIA	Video select A
20	VCC	EX3.3	Power supply

• **Microprocessor ADC select port**

IC401: ADC084S021CIMM (DSP P.C.B.)
4-channel, 200 kSPS, 8-bit A/D converter

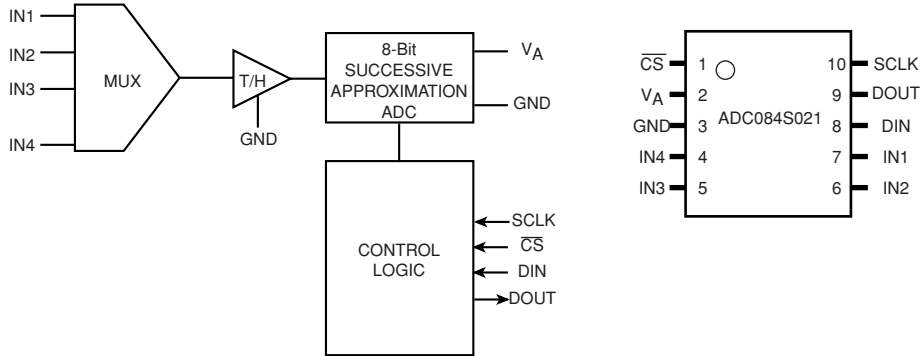

Pin No.	Port Name	Function Name	Detail of Function
1	/CS	/SPISEL1	CS for microprocessor
2	VA	VA	+3.3S
3	GND	DGND	Ground of external
4	IN4	IN4	Analog value from selector (IC402)
5	IN3	IN3	Analog value from selector (IC403)
6	IN2	KEY1	Key input 1
7	IN1	KEY0	Key input 0
8	DIN	SPIMO	Master output/slave input
9	DOUT	SPIMI	Master input/slave output
10	SCLK	SPISCK	SPI clock

Key input (A/D), pull-up resistance 10 k-ohms

Ohm [ohm]	+1.0 k	+1.0 k	+1.5 k	+2.2 k	+3.3 k	+4.7 k	+4.7 k	+6.8 k	+10.0 k	+22.0 k
V [V]	0.3	0.55	0.86	1.2	1.56	1.91	2.14	2.36	2.57	2.81
KEY0 (7 pin)	SCENE 1	SCENE 2	PROGRAM <	PROGRAM >	STRAIGHT	TONE CONTROL	SEARCH MODE	FM/AM	A/B/C/D/E	SPEAKERS
KEY1 (6 pin)	SCENE 3	SCENE 4	DIRECT	AUDIO SELECT	INPUT <	INPUT >	PRESET/TUNING <	PRESET/TUNING >	MEMORY	TUNING

IC402, IC403: SN74LV4051APWR (DSP P.C.B.)
8-channel analog multiplexers/demultiplexers

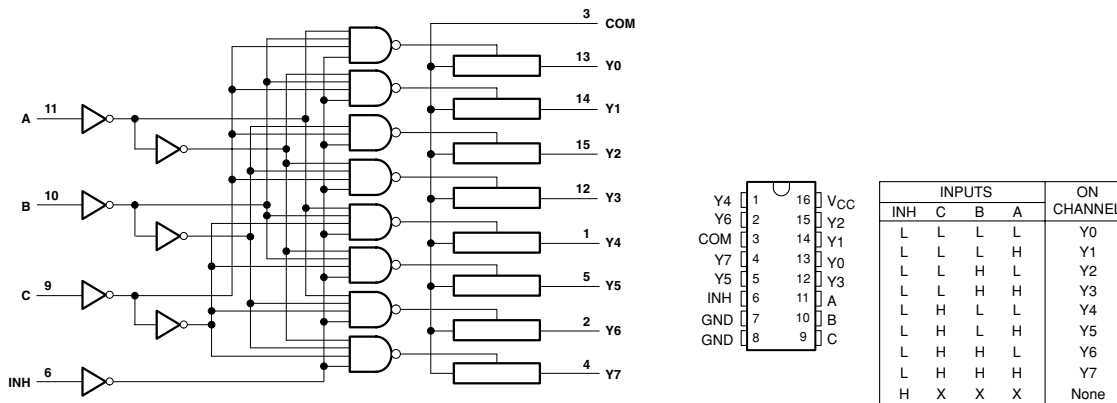

RX-V461/HTR-6040/RX-V461DAB

IC402

Pin No.	Port Name	Function Name	Detail of Function
1	Y4	iPAP	DOCK (iPod) detect (ACCPOW) (B model)
2	Y6	DEST2	Destination 2 *
3	COM	COM	Analog value to IN4 (IC401)
4	Y7	LINKACTIVE	
5	Y5	XM_MUTE	
6	INH	DGND	(Pull-down)
7	GND	DGND	Ground of external
8	GND	DGND	Ground of external
9	C	ADSEL2	Input select 2
10	B	ADSEL1	Input select 1
11	A	ADSEL0	Input select 0
12	Y3	iPDET	DOCK (iPod) detect (iPDET) (B model)
13	Y0	/MIC	MIC detect
14	Y1	/ST	Stereo for tuner
15	Y2	/TUNED	Tuned for tuner
16	Vcc	+3.3S	Power supply

* Destination for A/D port

R416 [ohm]	6.8 k	8.2 k	8.2 k
R410 [ohm]	5.6 k	2.2 k	1.0 k
DEST (1 pin) [V]	1.3-1.7	0.5-0.9	0.2-0.5
A/D value (3.3 V=255)	100-132	42-69	16-41
Destination	T	B	G, E

IC403

Pin No.	Port Name	Function Name	Detail of Function
1	Y4	DEST	Destination 1 (fixed)
2	Y6	/PDET	Sub-trans detect
3	COM	COM	Analog value to IN3 (IC401)
4	Y7	/HP	Headphone detect
5	Y5	PRIIN	Current protection
6	INH	DGND	(Pull-down)
7	GND	DGND	Ground of external
8	GND	DGND	Ground of external
9	C	ADSEL2	Input select 2
10	B	ADSEL1	Input select 1
11	A	ADSEL0	Input select 0
12	Y3	PLDET	Limiter detect
13	Y0	PRDIN	Amplifier DC detect
14	Y1	PRVIN	Voltage protection
15	Y2	THMIN	Thermo protection
16	Vcc	+3.3S	Power supply

IC301: AK4588VQ (DSP P.C.B.)
2/8-channel audio CODEC with DIR

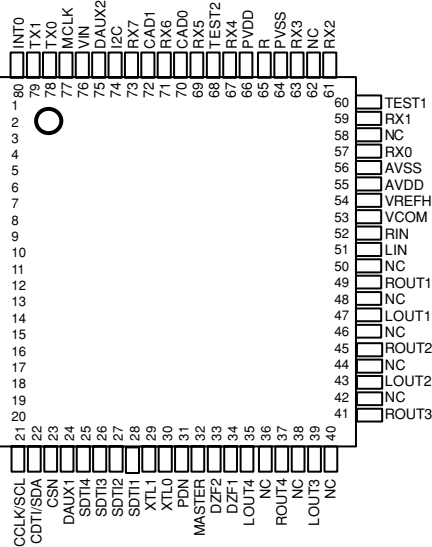
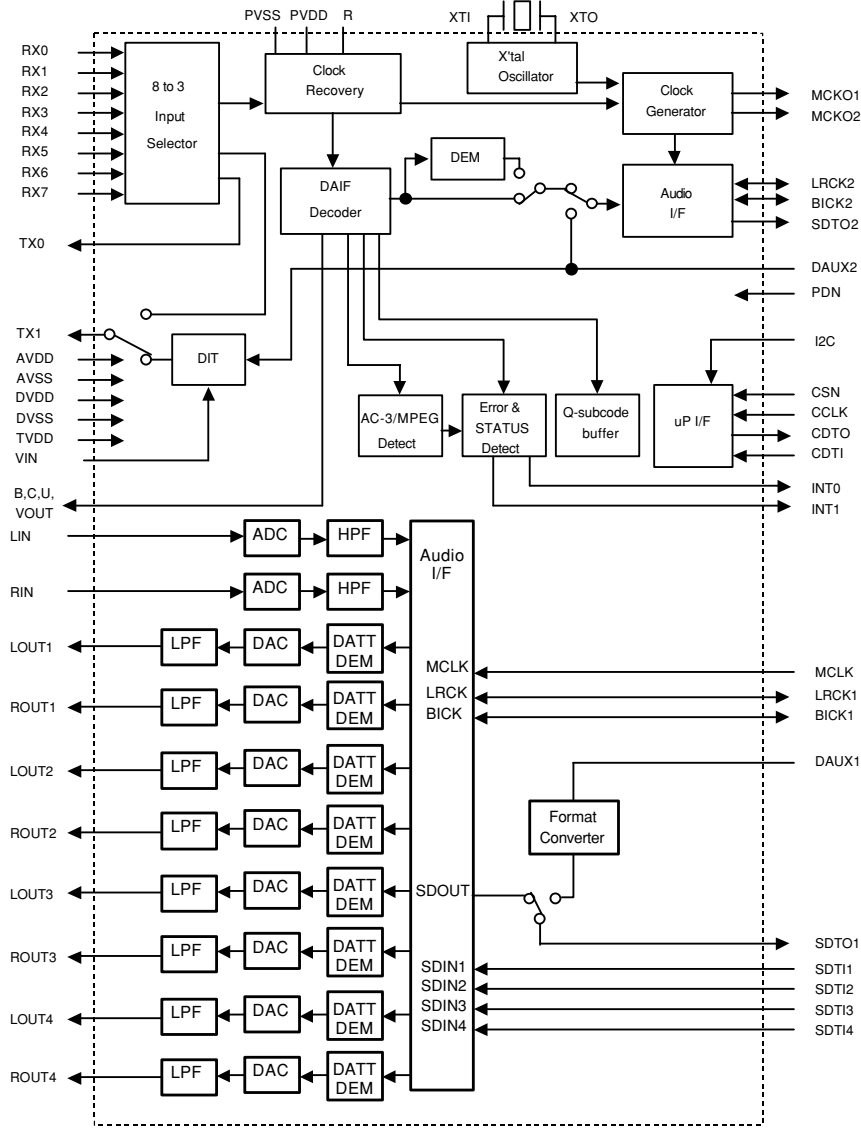

RX-V461/HTR-6040/
RX-V461DAB

Pin No.	Function Name	I/O	Detail of Function
1	INT1	O	Interrupt 1 pin
2	BOUT	O	Block-start output pin for receiver input "H" during first 40 flames
3	TVDD	–	Output buffer power supply pin, 2.7 V to 5.5 V
4	DVDD	–	Digital power supply pin, 4.5 V to 5.5 V
5	DVSS	–	Digital ground pin
6	XTO	O	X'tal clock output pin
7	XTI	I	X'tal / External clock input pin
8	TEST3	I	Test 3 pin This pin should be connected to DVSS
9	MCKO2	O	Master clock output 2 pin
10	MCKO1	O	Master clock output 1 pin
11	COUT	O	C-bit output pin for receiver input
12	UOUT	O	U-bit output pin for receiver input
13	VOUT	O	V-bit output pin for receiver input
14	SDTO2	O	Audio serial data output pin (DIR/DIT part)
15	BICK2	I/O	Audio serial data clock pin (DIR/DIT part)
16	LRCK2	I/O	Channel clock pin (DIR/DIT part)
17	SDTO1	O	Audio serial data output pin (ADC/DAC part)
18	BICK1	I/O	Audio serial data clock pin (ADC/DAC part)
19	LRCK1	I/O	Input channel clock pin
20	CDTO	O	Control data output pin in serial mode, I2C pin= "L"
21	CCLK	I	Control data clock pin in serial mode, I2C pin= "L"
	SCL	I	Control data clock pin in serial mode, I2C pin= "H"
22	CDTI	I	Control data input pin in serial mode, I2C pin= "L"
	SDA	I/O	Control data pin in serial mode, I2C pin= "H"
23	CSN	I	Chip select pin in serial mode, I2C pin="L"
		I	This pin should be connected to DVSS, I2C pin="H"
24	DAUX1	I	AUX audio serial data input pin (ADC/DAC part)
25	SDTI4	I	DAC4 audio serial data input pin
26	SDTI3	I	DAC3 audio serial data input pin
27	SDTI2	I	DAC2 audio serial data input pin
28	SDTI1	I	DAC1 audio serial data input pin
29	XTL1	I	X'tal frequency select 0 pin
30	XTL0	I	X'tal frequency select 1 pin
31	PDN	I	Power-down mode pin When "L", the AK4588 is powered-down, all output pin goes "L", all registers are reset When CAD1-0 pins are changed, the AK4588 should be reset by PDN pin
32	MASTER	I	Master mode select pin "H": Master mode, "L": Slave mode
33	DZF2	O	Zero input detect 2 pin (table 13) When the input data of the group 1 follow total 8192 LRCK cycles with "0" input data, this pin goes to "H" / When RSTN1 bit is "0" or PWDAN bit is "0", this pin goes to "H"
	OVF	O	Analog input overflow detect pin This pin goes to "H" if the analog input of L ch or R ch overflows This pin becomes OVF pin if OVFE bit is set to 1
34	DZF1	O	Zero input detect 1 pin (table 13) When the input data of the group 1 follow total 8192 LRCK cycles with "0" input data, this pin goes to "H" / When RSTN1 bit is "0" or PWDAN bit is "0", this pin goes to "H"
35	LOUT4	O	DAC4 L ch analog output pin
36	NC	–	No connect pin No internal bonding / This pin should be opened
37	ROUT4	O	DAC4 R ch analog output pin
38	NC	–	No connect pin No internal bonding / This pin should be opened
39	LOUT3	O	DAC3 L ch analog output pin
40	NC	–	No connect pin No internal bonding / This pin should be opened

Pin No.	Function Name	I/O	Detail of Function
41	ROUT3	O	DAC3 R ch analog output pin
42	NC	–	No connect pin No internal bonding / This pin should be opened
43	LOUT2	O	DAC2 L ch analog output pin
44	NC	–	No connect pin No internal bonding / This pin should be opened
45	ROUT2	O	DAC2 R ch analog output pin
46	NC	–	No connect pin No internal bonding / This pin should be opened
47	LOUT1	O	DAC1 L ch analog output pin
48	NC	–	No connect pin No internal bonding / This pin should be opened
49	ROUT1	O	DAC1 R ch analog output pin
50	NC	–	No connect pin No internal bonding / This pin should be opened
51	LIN	I	L ch analog input pin
52	RIN	I	R ch analog input pin
53	VCOM	–	Common voltage output pin 2.2 F capacitor should be connected to AVSS externally
54	VREFH	–	Positive voltage reference input pin, AVDD
55	AVDD	–	Analog power supply pin, 4.5 V to 4.5 V
56	AVSS	–	Analog ground pin, 0 V
57	RX0	I	Receiver channel 0 pin (Internal biased pin / Internally biased at PVDD/2)
58	NC	–	No connect pin No internal bonding / This pin should be connected to PVSS
59	RX1	I	Receiver channel 1 pin (Internal biased pin / Internally biased at PVDD/2)
60	TEST1	I	Test 1 pin This pin should be connected to PVSS
61	RX2	I	Receiver channel 2 pin (Internal biased pin / Internally biased at PVDD/2)
62	NC	–	No connect pin No internal bonding / This pin should be connected to PVSS
63	RX3	I	Receiver channel 3 pin (Internal biased pin / Internally biased at PVDD/2)
64	PVSS	–	PLL ground pin
65	R	–	External resistor pin 12 k-ohms +/-1 % resistor should be connected to PVSS externally
66	PVDD	–	PLL power supply pin, 4.5 V to 4.5 V
67	RX4	I	Receiver channel 4 pin (Internal biased pin / Internally biased at PVDD/2)
68	TEST2	I	Test 2 pin This pin should be connected to PVSS
69	RX5	I	Receiver channel 5 pin (Internal biased pin / Internally biased at PVDD/2)
70	CAD0	I	Chip address 0 pin (ADC/DAC part)
71	RX6	I	Receiver channel 6 pin (Internal biased pin / Internally biased at PVDD/2)
72	CAD1	I	Chip address 1 pin (ADC/DAC part)
73	RX7	I	Receiver channel 7 pin (Internal biased pin / Internally biased at PVDD/2)
74	I2C	I	Control mode select pin “L”: 4-wire serial, “H”: I2C bus
75	DAUX2	I	Auxiliary audio data input pin (DIR/DIT part)
76	VIN	I	V-bit input pin for transmitter output
77	MCLK	I	Master clock input pin
78	TX0	O	Transmit channel (through data) output 0 pin
79	TX1	O	Transmit channel output 1 pin When TX bit = “0”, transmit channel (through data) output 1 pin. When TX bit = “1”, transmit channel (DAUX2 data) output pin (default)
80	INT0	O	Interrupt 0 pin

Note: All input pins except internal biased pins and internal pull-down pin should not be left floating.

IC161: R2A15215FP (MAIN P.C.B.)

8-channel electronic volume with 11 input selector and tone control

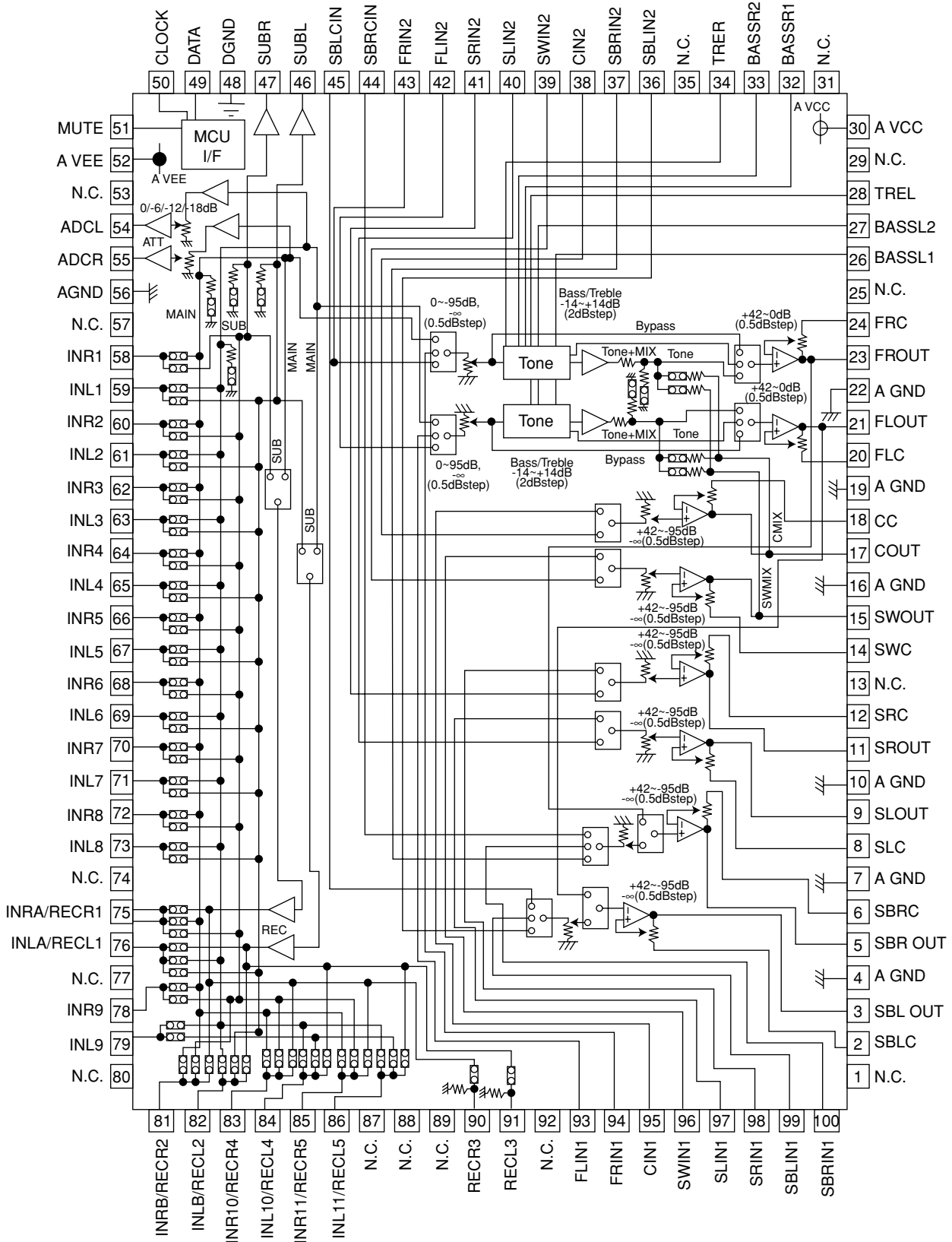

Pin No.	Function Name	Detail of Function
1	N.C.	No connected
2	SBLC	L/R/C/SW/SL/SR/SBL/SBR ch terminal to connect capacitor to reduce noise from changing the volume
3	SBLOUT	FL/FR/C/SW/SL/SR/SBL/SBR ch output terminal
4	AGND	Analog GND terminal
5	SBROUT	FL/FR/C/SW/SL/SR/SBL/SBR ch output terminal
6	SBRC	L/R/C/SW/SL/SR/SBL/SBR ch terminal to connect capacitor to reduce noise from changing the volume
7	AGND	Analog GND terminal
8	SLC	L/R/C/SW/SL/SR/SBL/SBR ch terminal to connect capacitor to reduce noise from changing the volume
9	SLOUT	FL/FR/C/SW/SL/SR/SBL/SBR ch output terminal
10	AGND	Analog GND terminal
11	SROUT	FL/FR/C/SW/SL/SR/SBL/SBR ch output terminal
12	SRC	L/R/C/SW/SL/SR/SBL/SBR ch terminal to connect capacitor to reduce noise from changing the volume
13	N.C.	No connected
14	SWC	L/R/C/SW/SL/SR/SBL/SBR ch terminal to connect capacitor to reduce noise from changing the volume
15	SWOUT	FL/FR/C/SW/SL/SR/SBL/SBR ch output terminal
16	AGND	Analog GND terminal
17	COUT	FL/FR/C/SW/SL/SR/SBL/SBR ch output terminal
18	CC	L/R/C/SW/SL/SR/SBL/SBR ch terminal to connect capacitor to reduce noise from changing the volume
19	AGND	Analog GND terminal
20	FLC	L/R/C/SW/SL/SR/SBL/SBR ch terminal to connect capacitor to reduce noise from changing the volume
21	FLOUT	FL/FR/C/SW/SL/SR/SBL/SBR ch output terminal
22	AGND	Analog GND terminal
23	FROUT	FL/FR/C/SW/SL/SR/SBL/SBR ch output terminal
24	FRC	L/R/C/SW/SL/SR/SBL/SBR ch terminal to connect capacitor to reduce noise from changing the volume
25	N.C.	No connected
26	BASSL1	L/R ch tone control (Bass) terminal for setting frequency characteristics
27	BASSL2	L/R ch tone control (Bass) terminal for setting frequency characteristics
28	TREL	L/R ch tone control (Treble) terminal for setting frequency characteristics
29	N.C.	No connected
30	AVCC	Positive side power terminal
31	N.C.	No connected
32	BASSR1	L/R ch tone control (Bass) terminal for setting frequency characteristics
33	BASSR2	L/R ch tone control (Bass) terminal for setting frequency characteristics
34	TRER	L/R ch tone control (Treble) terminal for setting frequency characteristics
35	N.C.	No connected
36	SBLIN2	L/R/C/SW/SL/SR/SBL/SBR ch input terminal (multi input 1/2)
37	SBRIN2	L/R/C/SW/SL/SR/SBL/SBR ch input terminal (multi input 1/2)
38	CIN2	L/R/C/SW/SL/SR/SBL/SBR ch input terminal (multi input 1/2)
39	SWIN2	L/R/C/SW/SL/SR/SBL/SBR ch input terminal (multi input 1/2)
40	SLIN2	L/R/C/SW/SL/SR/SBL/SBR ch input terminal (multi input 1/2)
41	SRIN2	L/R/C/SW/SL/SR/SBL/SBR ch input terminal (multi input 1/2)
42	FLIN2	L/R/C/SW/SL/SR/SBL/SBR ch input terminal (multi input 1/2)
43	FRIN2	L/R/C/SW/SL/SR/SBL/SBR ch input terminal (multi input 1/2)
44	SBRCIN	SBL/SBR ch volume input terminal
45	SBLCIN	SBL/SBR ch volume input terminal
46	SUBL	L/R ch SUB output terminal
47	SUBR	L/R ch SUB output terminal
48	DGND	Digital GND terminal
49	DATA	Control data input terminal
50	CLOCK	Control data input terminal
51	MUTE	External mute control terminal
52	AVEE	Negative side power terminal
53	N.C.	No connected
54	ADCL	L/R ch ADC output terminal
55	ADCR	L/R ch ADC output terminal

Pin No.	Function Name	Detail of Function
56	AGND	Analog GND terminal
57	N.C.	No connected
58	INR1	L/R ch input terminal (input selector)
59	INL1	L/R ch input terminal (input selector)
60	INR2	L/R ch input terminal (input selector)
61	INL2	L/R ch input terminal (input selector)
62	INR3	L/R ch input terminal (input selector)
63	INL3	L/R ch input terminal (input selector)
64	INR4	L/R ch input terminal (input selector)
65	INL4	L/R ch input terminal (input selector)
66	INR5	L/R ch input terminal (input selector)
67	INL5	L/R ch input terminal (input selector)
68	INR6	L/R ch input terminal (input selector)
69	INL6	L/R ch input terminal (input selector)
70	INR7	L/R ch input terminal (input selector)
71	INL7	L/R ch input terminal (input selector)
72	INR8	L/R ch input terminal (input selector)
73	INL8	L/R ch input terminal (input selector)
74	N.C.	No connected
75	INRA/RECR1	L/R ch input terminal (input selector) / L/R ch REC output terminal
76	INLA/RECL1	L/R ch input terminal (input selector) / L/R ch REC output terminal
77	N.C.	No connected
78	INR9	L/R ch input terminal (input selector)
79	INL9	L/R ch input terminal (input selector)
80	N.C.	No connected
81	INRB/RECR2	L/R ch input terminal (input selector) / L/R ch REC output terminal
82	INLB/RECL2	L/R ch input terminal (input selector) / L/R ch REC output terminal
83	INR10/RECR4	L/R ch input terminal (input selector) / L/R ch REC output terminal
84	INL10/RECL4	L/R ch input terminal (input selector) / L/R ch REC output terminal
85	INR11/RECR5	L/R ch input terminal (input selector) / L/R ch REC output terminal
86	INL11/RECL5	L/R ch input terminal (input selector) / L/R ch REC output terminal
87	N.C.	No connected
88	N.C.	No connected
89	N.C.	No connected
90	RECR3	L/R ch REC output terminal
91	RECL3	L/R ch REC output terminal
92	N.C.	No connected
93	FLIN1	L/R/C/SW/SL/SR/SBL/SBR ch input terminal (multi input 1/2)
94	FRIN1	L/R/C/SW/SL/SR/SBL/SBR ch input terminal (multi input 1/2)
95	CIN1	L/R/C/SW/SL/SR/SBL/SBR ch input terminal (multi input 1/2)
96	SWIN1	L/R/C/SW/SL/SR/SBL/SBR ch input terminal (multi input 1/2)
97	SLIN1	L/R/C/SW/SL/SR/SBL/SBR ch input terminal (multi input 1/2)
98	SRIN1	L/R/C/SW/SL/SR/SBL/SBR ch input terminal (multi input 1/2)
99	SBLIN1	L/R/C/SW/SL/SR/SBL/SBR ch input terminal (multi input 1/2)
100	SBRIN1	L/R/C/SW/SL/SR/SBL/SBR ch input terminal (multi input 1/2)

IC201: M66003-0131FP-R (OPERATION P.C.B.)
18 digit 5x7 segment VFD controller/driver

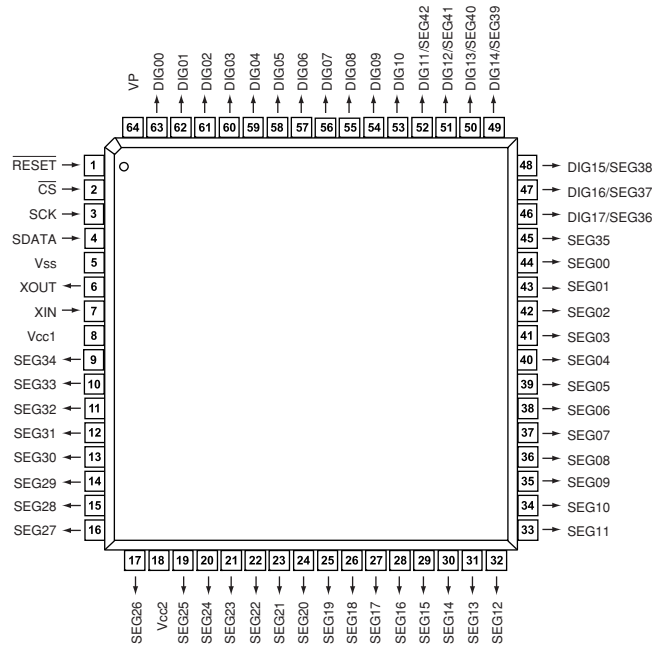
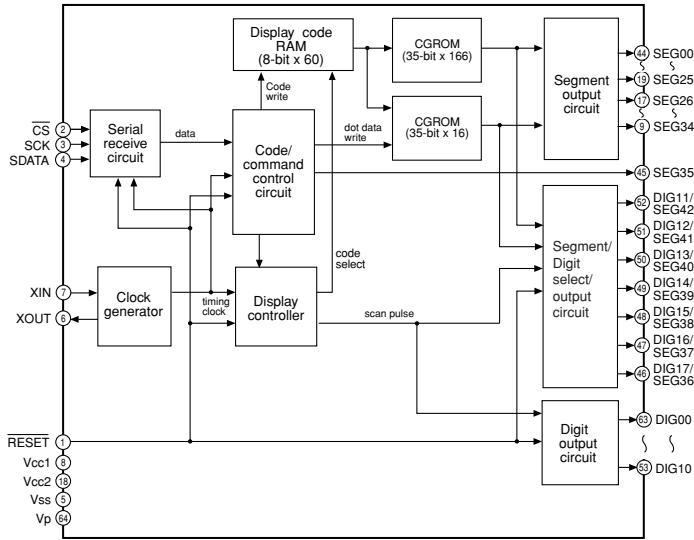

RX-V461/HTR-6040/
RX-V461DAB

Pin No.	Port Name	Function Name	I/O	Detail of Function
1	/RESET	Reset	Reset input	When "L", M66003 is initialized
2	/CEFL	CS	Chip select input	When "L", communication with the MCU is possible When "H", any instruction from the MCU is neglected
3	CKFL	SCK	Shift clock input	Serial input data is taken and shifted by the positive edge of SCK
4	DTFL	SDATA	Serial data input	
5	VSS	Vss		GND (0V)
6	XOUT	XOUT	Clock output	When use as a CR oscillator, connect external resistor and capacitor / When use an external clock, input external clock to XIN, and XOUT must be opened
7	XIN	XIN	Clock input	
8	VDD	Vcc1		Positive power supply for internal logic
9	P11	SEG34	Segment output	Positive power supply for DIG and SEG outputs
10	P2	SEG33	Segment output	
11	P3	SEG32	Segment output	
12	P4	SEG31	Segment output	
13	P5	SEG30	Segment output	
14	P6	SEG29	Segment output	
15	P7	SEG28	Segment output	
16	P8	SEG27	Segment output	
17	P9	SEG26	Segment output	
18	VDD	Vcc2		
19	P10	SEG25	Segment output	Connect to segment (anode) pins of VFD
20	P11	SEG24	Segment output	
21	P12	SEG23	Segment output	
22	P13	SEG22	Segment output	
23	P14	SEG21	Segment output	
24	P15	SEG20	Segment output	
25	P16	SEG19	Segment output	
26	P17	SEG18	Segment output	
27	P18I	SEG17	Segment output	
28	P19	SEG16	Segment output	
29	P20	SEG15	Segment output	
30	P21	SEG14	Segment output	
31	P22	SEG13	Segment output	
32	P23	SEG12	Segment output	
33	P24	SEG11	Segment output	
34	P25	SEG10	Segment output	
35	P26	SEG09	Segment output	
36	P27	SEG08	Segment output	
37	P28	SEG07	Segment output	
38	P29	SEG06	Segment output	
39	P30	SEG05	Segment output	
40	P31	SEG04	Segment output	
41	P32	SEG03	Segment output	
42	P33	SEG02	Segment output	
43	P34	SEG01	Segment output	
44	P35	SEG00	Segment output	
45	P36	SEG35	Segment output	
46	P37	DIG17/SEG36	Segment output	
47	G17I	DIG16/SEG37	Digit output	Connect to digit (grid) pins of VFD
48	G16I	DIG15/SEG38	Digit output	
49	G15I	DIG14/SEG39	Digit output	
50	G14	DIG13/SEG40	Digit output	
51	G13	DIG12/SEG41	Digit output	
52	G12	DIG11/SEG42	Digit output	
53	G11	DIG10	Digit output	
54	G10	DIG09	Digit output	
55	G9	DIG08	Digit output	
56	G8	DIG07	Digit output	
57	G7	DIG06	Digit output	
58	G6	DIG05	Digit output	
59	G5	DIG04	Digit output	
60	G4	DIG03	Digit output	
61	G3	DIG02	Digit output	
62	G2	DIG01	Digit output	
63	G1	DIG00	Digit output	
64	VP	Vp		Negative power supply to pull down

MEMO



Control Section

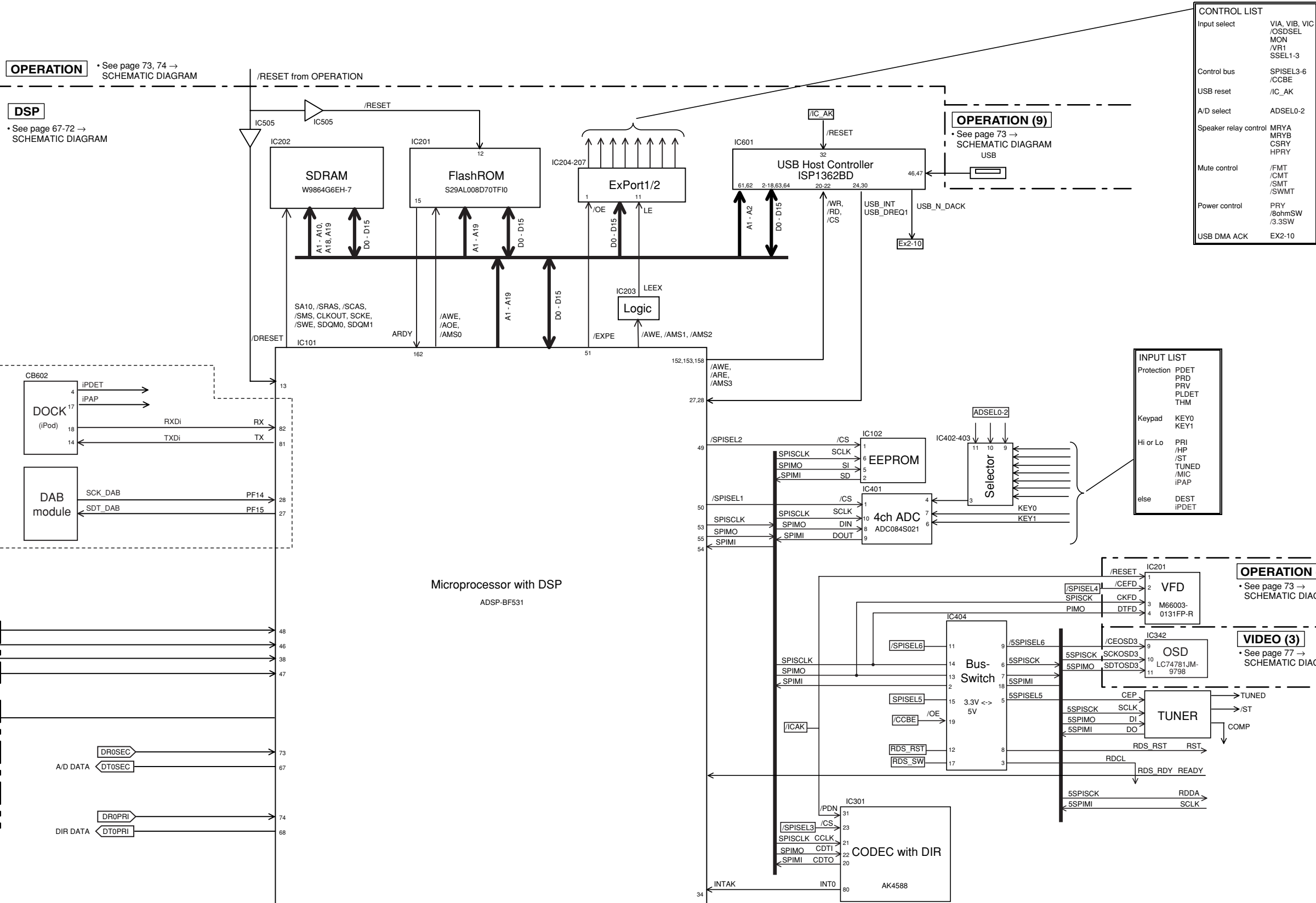

CONTROL LIST	
Input select	VIA, VIB, VIC /OSDSEL MON /VR1 SSEL1-3
Control bus	SPISSEL3-6 /CCBE
USB reset	/IC_AK
A/D select	ADSEL0-2
Speaker relay control	MRYA MRYB CSRY HPRY
Mute control	/FMT /CMT /SMT /SWMT
Power control	PRY /8ohmSW /3.3SW
USB DMA ACK	EX2-10

INPUT LIST	
Protection	PDET PRD PRV PLDET THM
Keypad	KEY0 KEY1
Hi or Lo	PRI /HP /ST /TUNED /MIC /PAP
else	DEST IPDET

OPERATION
• See page 73, 74 → SCHEMATIC DIAGRAM

MAIN
• See page 75, 76 → SCHEMATIC DIAGRAM

PIN CONNECTION DIAGRAMS

ICs

<p>ADC084S021 CIMM</p>	<p>ADSP-BF531 CPU</p>	<p>AK4588VQ</p>	<p>AZ4580MTR-E1</p>
<p>BR25L320F-W EEPROM</p>	<p>CXB1442AR-T4</p>	<p>KIA7805API KIA7812API</p>	<p>KIA79M05PI-U KIA7912PI</p>
<p>LA73050-TLM-E</p>	<p>LC74782JM-8A16-TLM</p>	<p>M66003-0131FP-R ISP1362BD</p>	<p>MM74HC4051SJX SN74CB3Q3257PWR</p>
<p>MIC2026-2BM</p>	<p>LC72725KM MM74HC4053SJX</p>	<p>NJM2388F05 NJM2388F33</p> <p>1. VIN 2. VOUT 3. GND 4. ON/OFF CONTROL</p>	<p>NJM2388F63</p> <p>1. IN 2. VOUT 3. GND 4. ON/OFF CONTROL</p>
<p>NJM2581M</p>	<p>NJM2867F3-05</p>	<p>NJM2885DL1-33</p> <p>1:VIN 2:GND 3:VOUT</p>	<p>R2A15215FP</p>
<p>SN74LVC2G17DCKR</p>	<p>SN74LVC1G08DCKR TC7S04FU TC7S32FU TC7S86FU TC7SZ08FU</p>	<p>S29AL016D70TFI020</p>	<p>SN74AHC02PWR SN74AHC08PWR SN74AHCT08PWR SN74LV08APWR SN74LVU04APWR</p>

<p>SN74CBTLV16210GR</p>	<p>SN74LV157APWR SN74LV4051APWR</p>	<p>SN74AHCT245PWR SN74LV573APWR</p>
<p>STK433-130-E</p>	<p>STK433-330-E</p>	<p>TC74HC4052AF</p>
<p>W9864G6EH-7</p>		

Diodes

<p>1SS133, 176 1SS270A MTZJ33B</p> <p>Anode Cathode</p>	<p>RB160L-40 TE25</p> <p>Anode Cathode</p>	<p>1SS355 MA8075-H MA8100-H RB500V-40 UDZ3.6BTE-17 UDZ5.1B UDZS3.3BTE-17 UDZS9.1B</p> <p>Anode Cathode</p>	<p>KDS160-RTK</p> <p>Anode Cathode</p>
<p>KBP103G 1.0A 200V</p> <p>AC +</p>	<p>1T2</p> <p>Anode Cathode</p>	<p>RS403M</p> <p>AC +</p>	<p>TS6P03G 6.0A 200V</p> <p>AC +</p>

Transistors

<p>2SA1015-AT 2N5401C-AT 2N5551C-AT</p> <p>E C B</p>	<p>2SA1037K 2SC2412K 2SC3326 2SD1938F</p> <p>C B E</p>	<p>2SA1708</p> <p>E C B</p>	<p>2SB1274</p> <p>B C E</p>
<p>2SC1740S</p> <p>B C E</p>	<p>2SC1815 2SC2705</p> <p>E C B</p>	<p>KRA102S-RTK/P KRA104S-RTK KRC102S-RTK KRC104S-RTK</p> <p>OUT COMMON IN</p>	<p>RTQ040P02</p> <p>1. Drain 2. Drain 3. Gate 4. Source 5. Drain 6. Drain</p>

PRINTED CIRCUIT BOARDS

DSP P.C.B. (Side A)

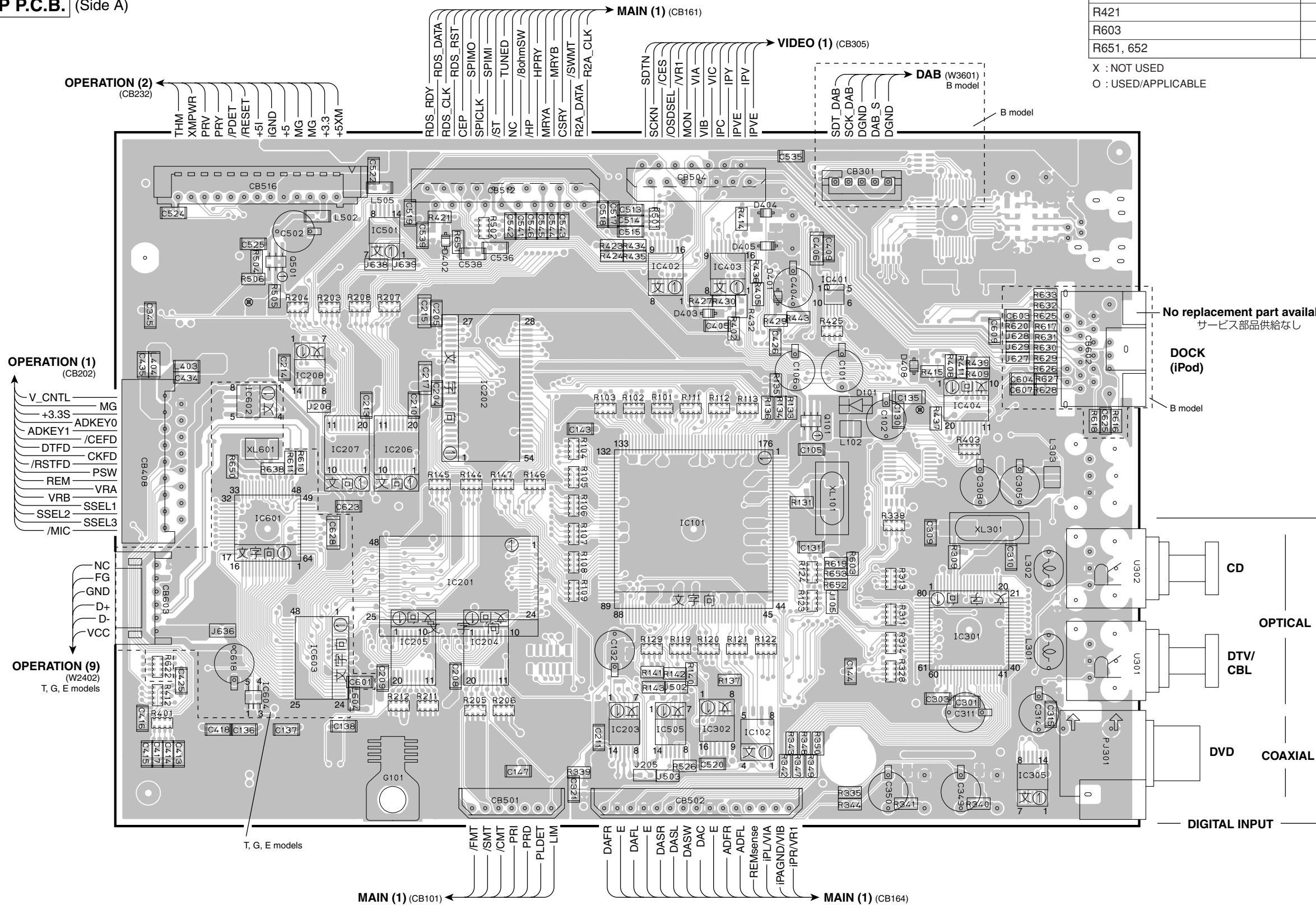

Circuit No.	T	B, G, E
D402	X	O
R409	X	O
R421	X	O
R603	X	O
R651, 652	X	O

X : NOT USED
O : USED/APPLICABLE

• Semiconductor Location

Ref no.	Location	Ref no.	Location
D101	G4	IC208	C4
D401	F3	IC301	G5
D402	D3	IC302	F6
D403	F3	IC305	H6
D404	F3	IC401	F3
D405	F3	IC402	E3
D408	G4	IC403	F3
IC101	F5	IC404	G4
IC102	F6	IC501	D3
IC201	D5	IC505	E6
IC202	D4	IC601	C5
IC203	E6	IC602	C5
IC204	D5	IC603	C5
IC205	D5	IC604	C6
IC206	D4	Q101	F4
IC207	D4	Q501	C3

No replacement part available.
サービス部品供給なし

DOCK (iPod)

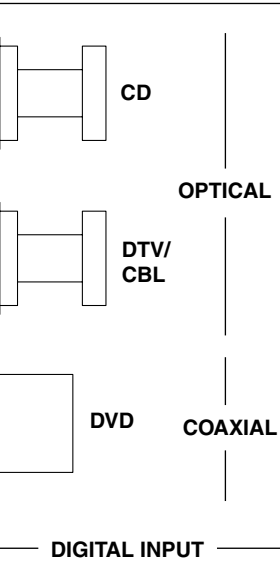

OPERATION (1) P.C.B. (Side A)

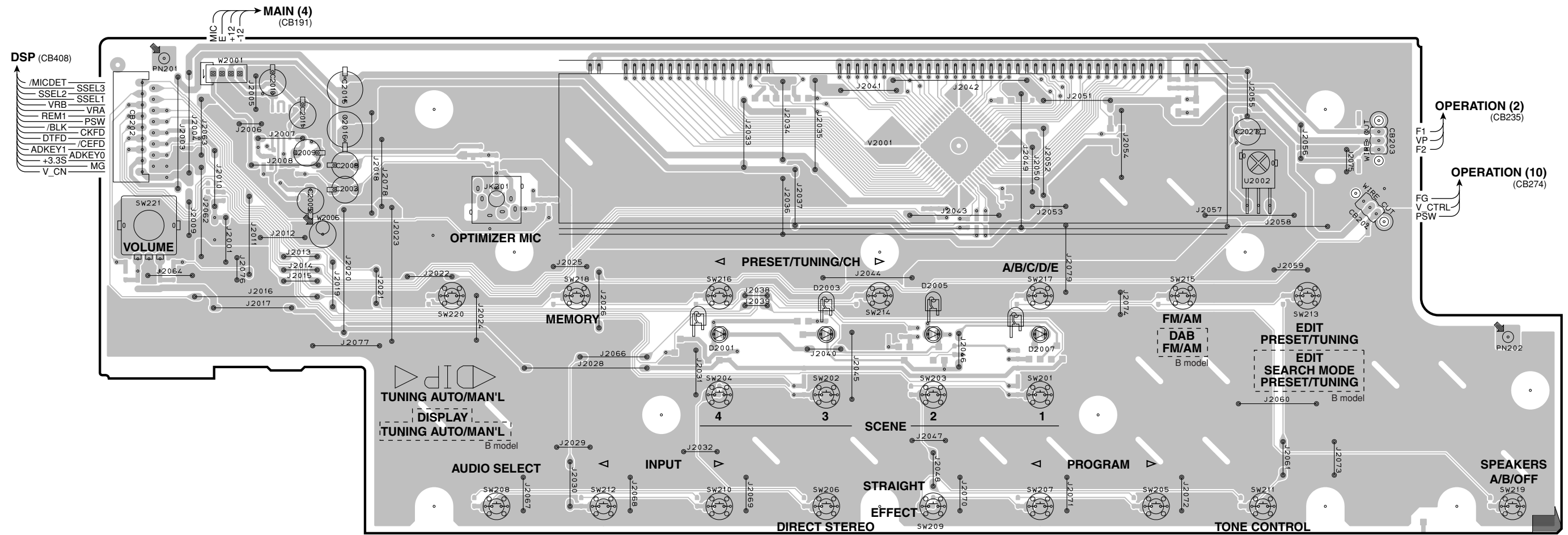

OPERATION (2)
(CB235)

OPERATION (10)
(CB274)

• **Semiconductor Location**

Ref no.	Location
D2001	E4
D2003	F4
D2005	F4
D2007	G4

OPERATION (1) P.C.B. (Side B)

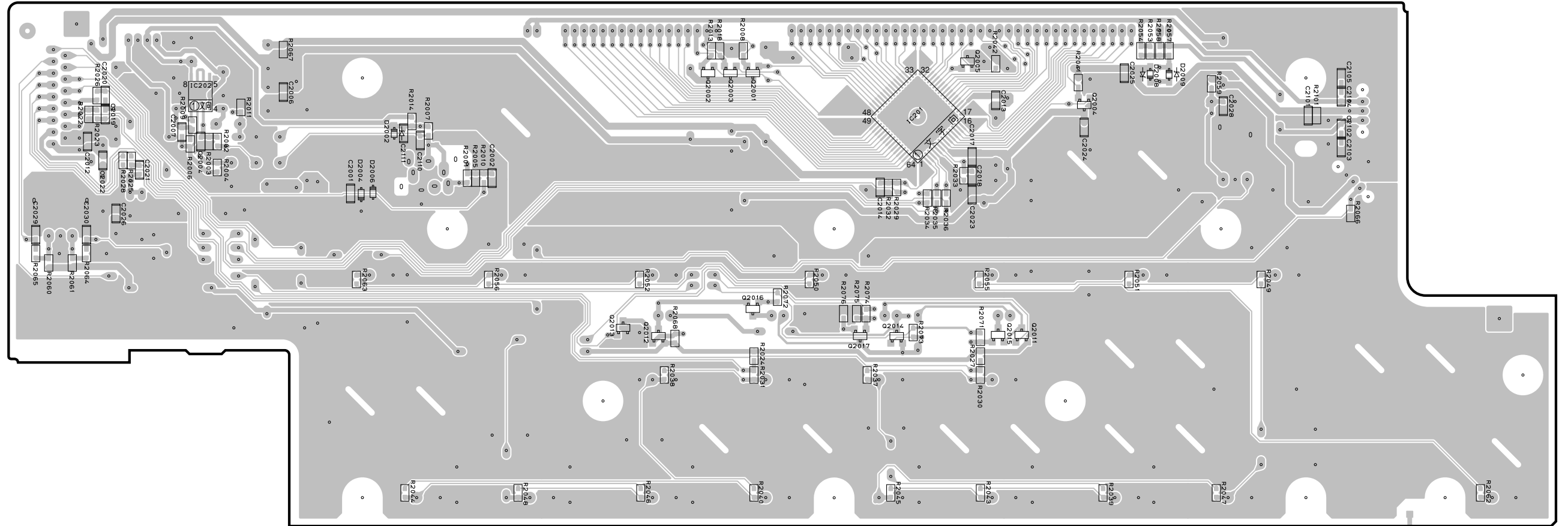

• **Semiconductor Location**

Ref no.	Location	Ref no.	Location
D2002	D3	Q2004	F3
D2004	C3	Q2005	G3
D2006	C3	Q2011	G4
D2008	H3	Q2012	E4
D2009	H3	Q2013	E4
IC201	G3	Q2014	F4
IC202	B3	Q2015	G4
Q2001	F3	Q2016	F4
Q2002	E3	Q2017	F4
Q2003	E3		

OPERATION (2) P.C.B. (Side A)

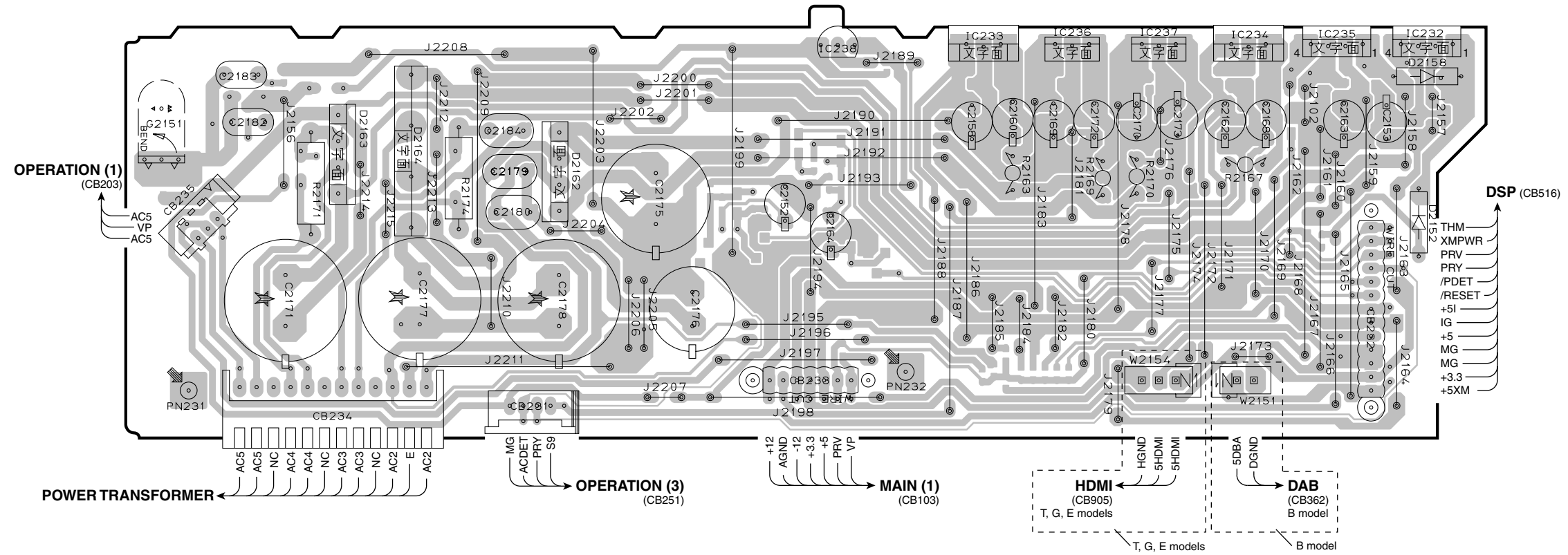

• Semiconductor Location

Ref no.	Location
D2152	H4
D2158	H3
D2162	D3
D2163	C3
D2164	C3
IC232	H3
IC233	F3
IC234	G3
IC235	H3
IC236	F3
IC237	G3
IC238	E3

OPERATION (2) P.C.B. (Side B)

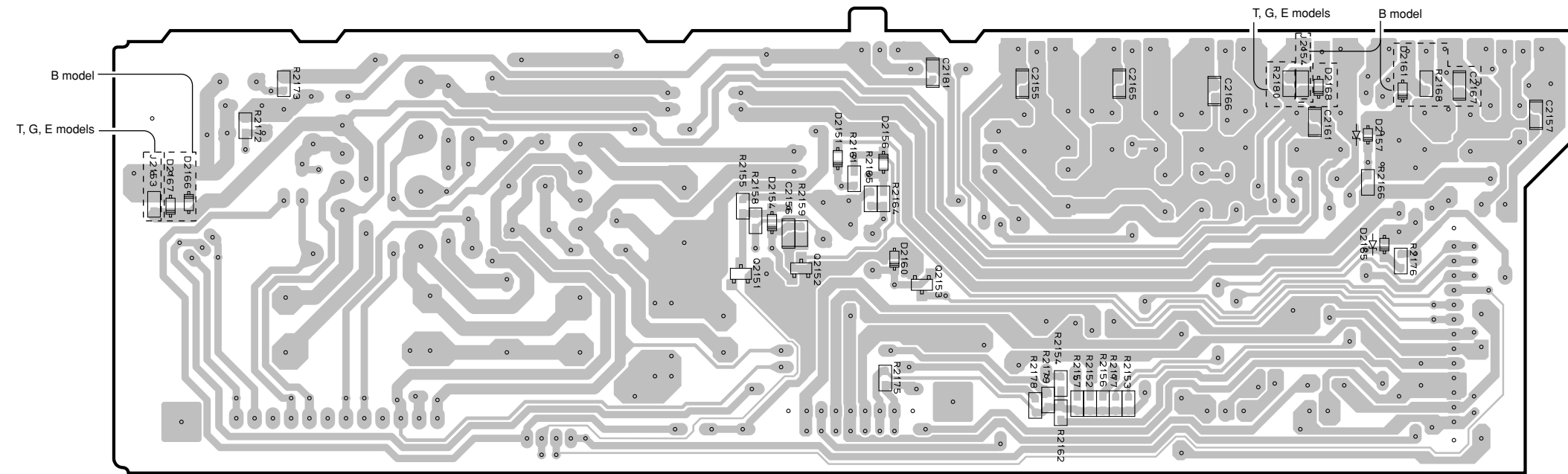

• Semiconductor Location

Ref no.	Location
D2151	E3
D2154	E4
D2156	E3
D2157	G3
D2160	E4
D2161	G3
D2165	G4
D2166	B3
D2167	B3
D2168	G3
Q2151	E4
Q2152	E4
Q2153	E4

OPERATION (3) P.C.B. (Side A)

OPERATION (3) P.C.B. (Side B)

OPERATION (4) P.C.B. (Side A)

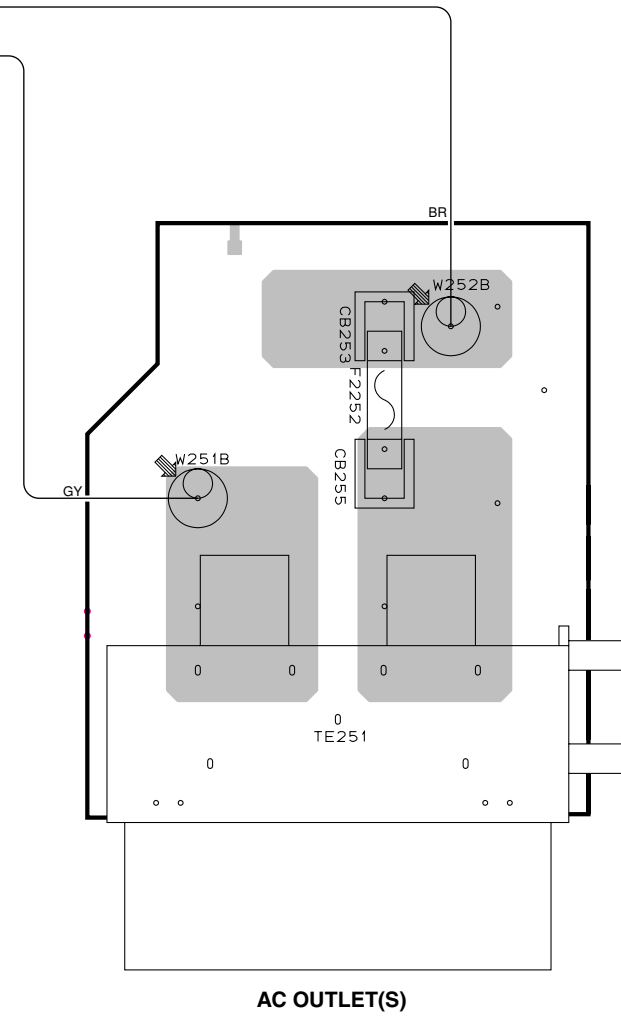
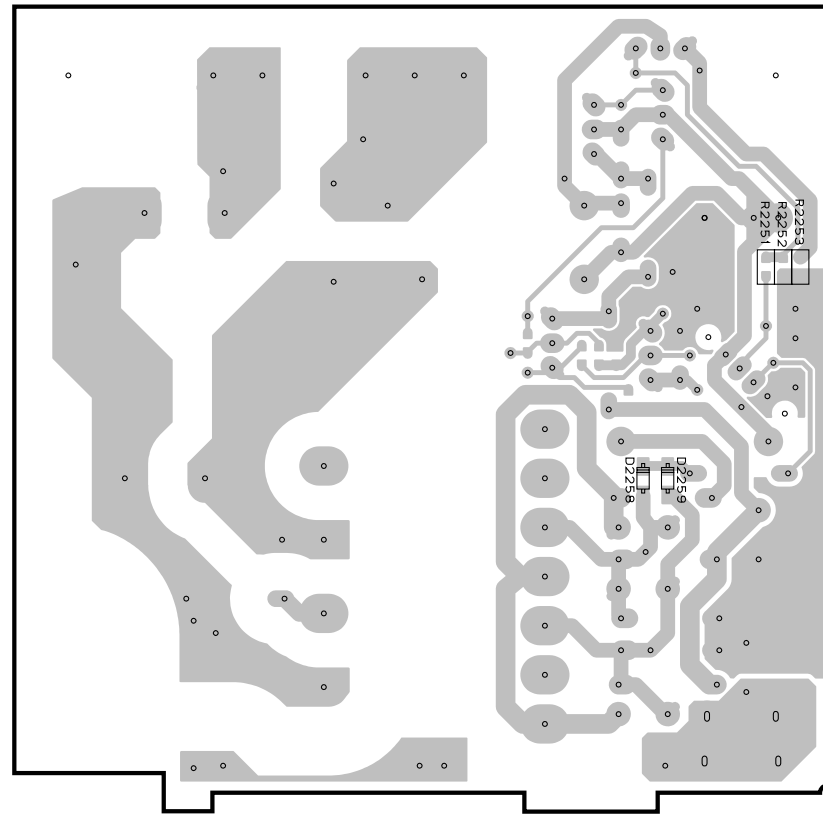
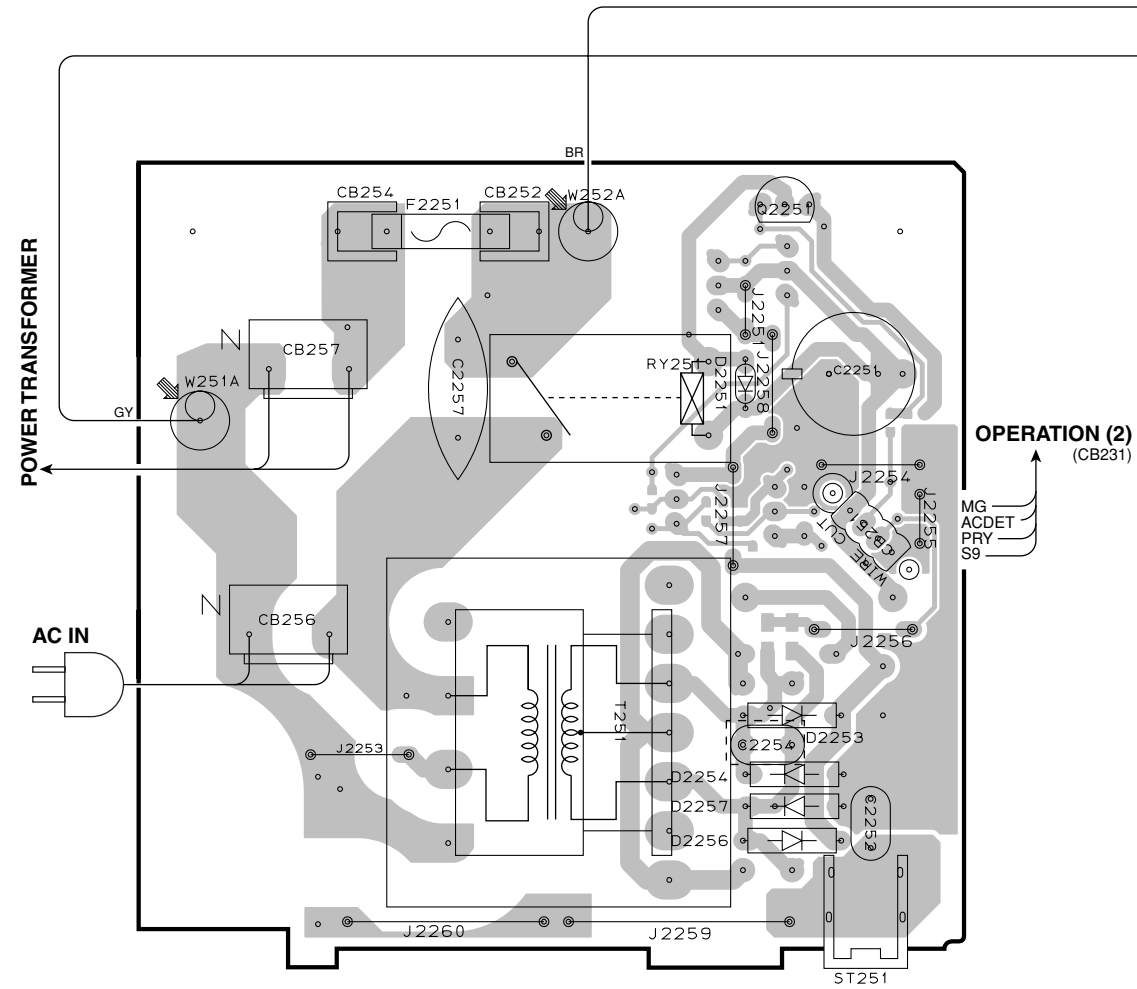

OPERATION (6) P.C.B. (Side A)

OPERATION (6) P.C.B. (Side B)

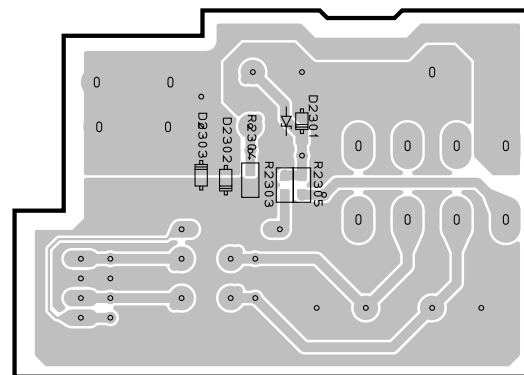
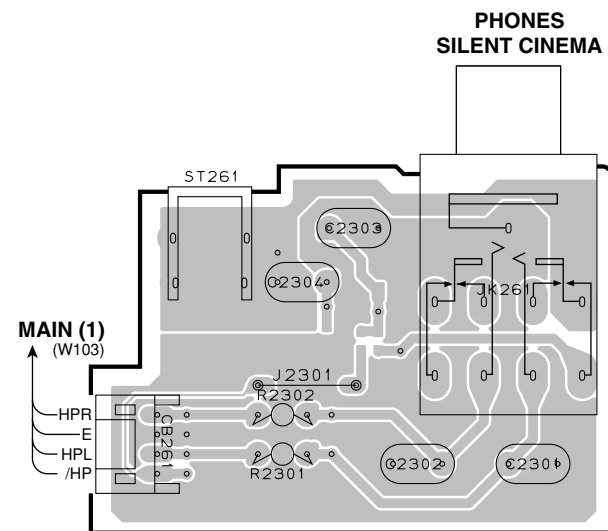

• Semiconductor Location

Ref no.	Location
D2251	C3
D2253	D4
D2254	D4
D2256	D4
D2257	D4
D2258	G4
D2259	G4
D2301	E6
D2302	E6
D2303	E6
Q2251	D2

MAIN (1) P.C.B. (Side B)

MAIN (4) P.C.B.

(Side B)

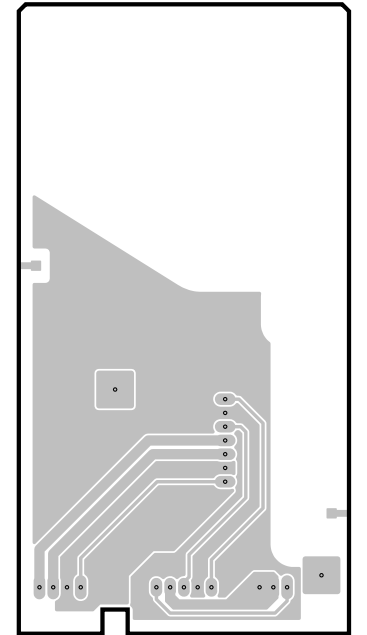
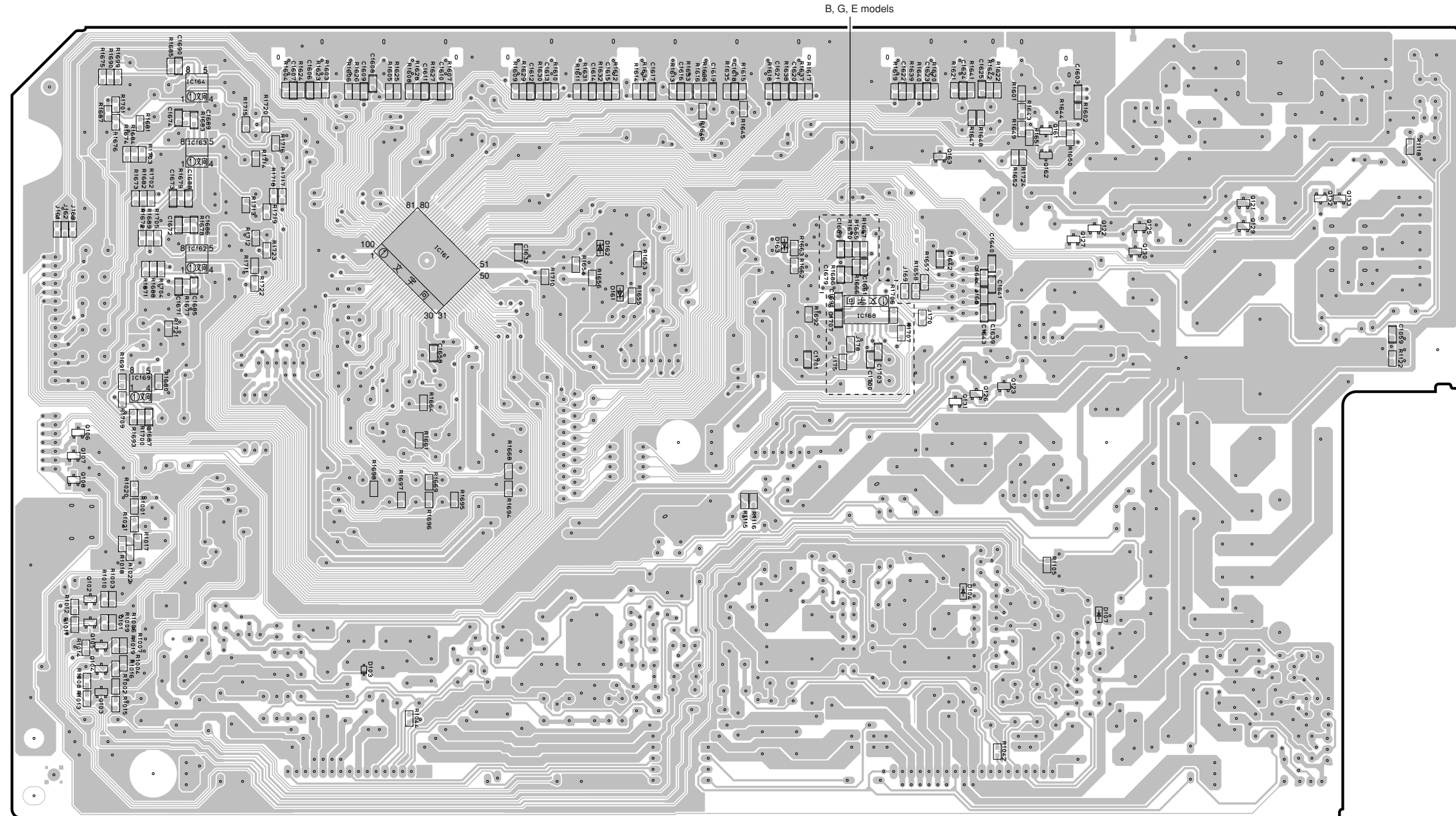

• **Semiconductor Location**

Ref no.	Location	Ref no.	Location
D103	C5	Q106	A4
D104	F5	Q107	A4
D107	G5	Q108	A4
D161	D3	Q121	G3
D162	D3	Q122	G3
D163	E3	Q123	F4
IC161	C3	Q125	G3
IC162	B3	Q126	F4
IC163	B3	Q127	G3
IC164	B2	Q129	G3
IC168	F3	Q130	G3
IC169	B4	Q131	F4
Q101	B5	Q132	H3
Q102	B5	Q133	H3
Q103	B5	Q161	F3
Q104	B5	Q162	F3
Q105	B5	Q163	F3

VIDEO (1) P.C.B. (Side A)

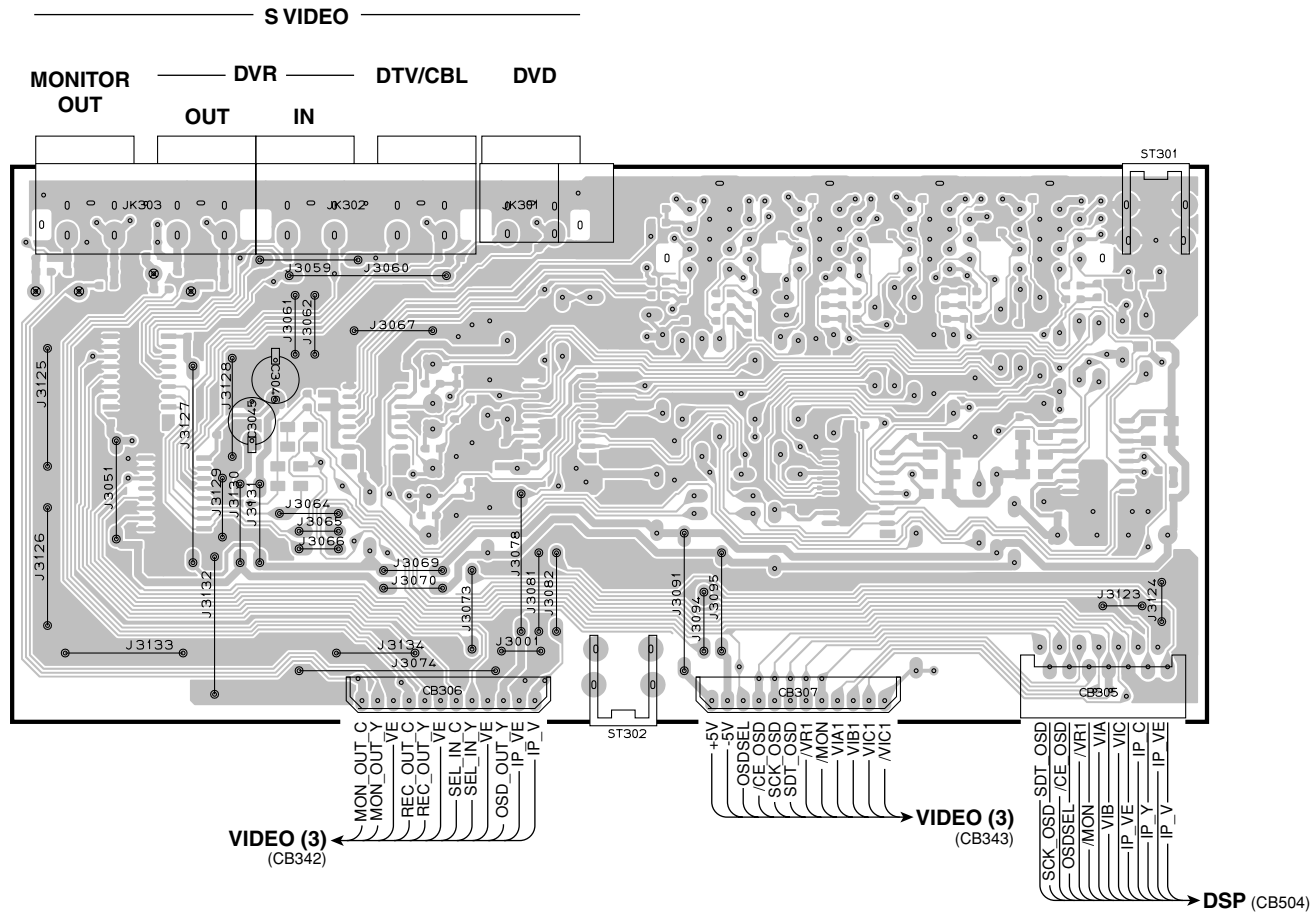

VIDEO (2) P.C.B. (Side A)

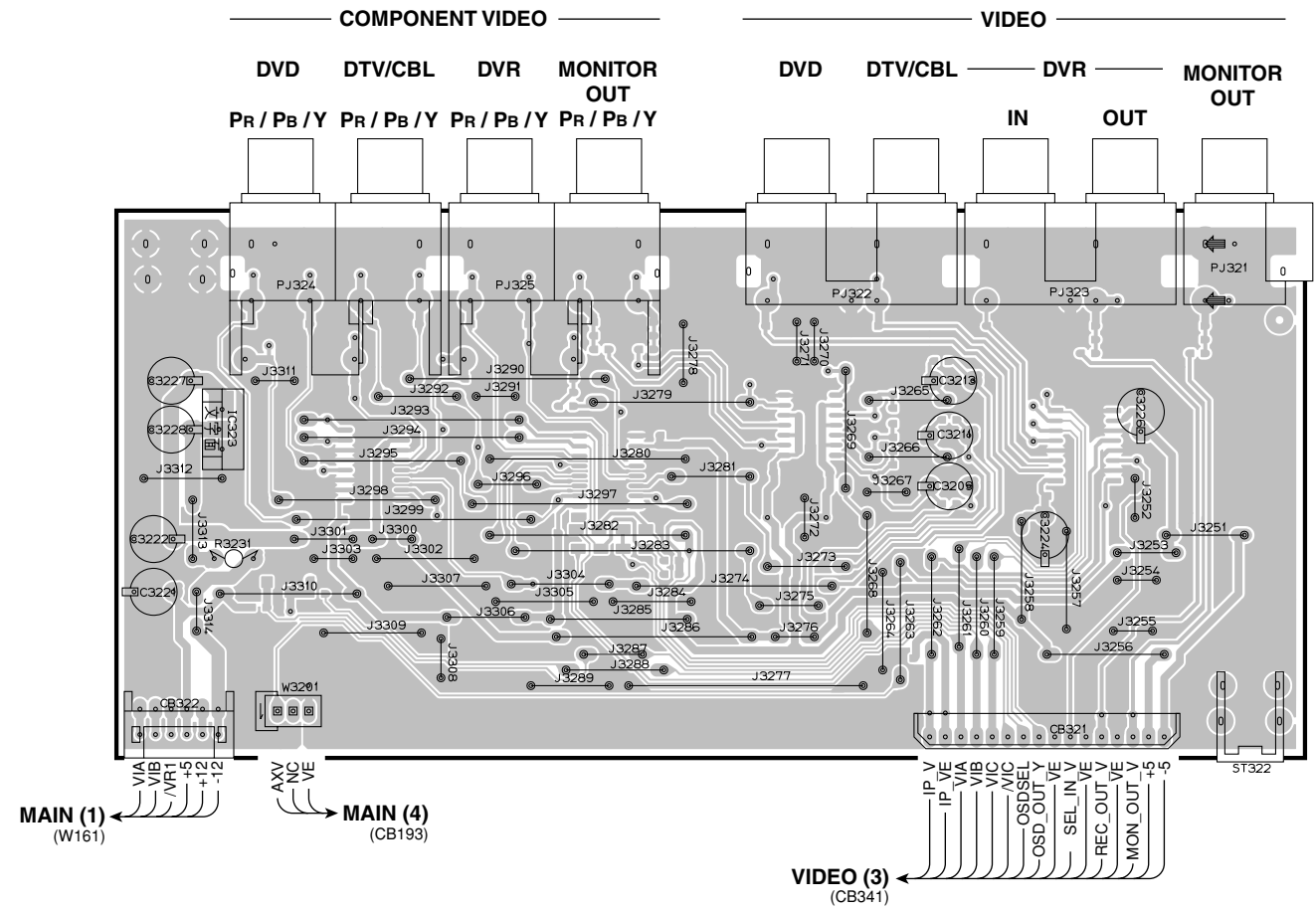

• **Semiconductor Location**

Ref no.	Location
IC323	F4

VIDEO (1) P.C.B. (Side B)

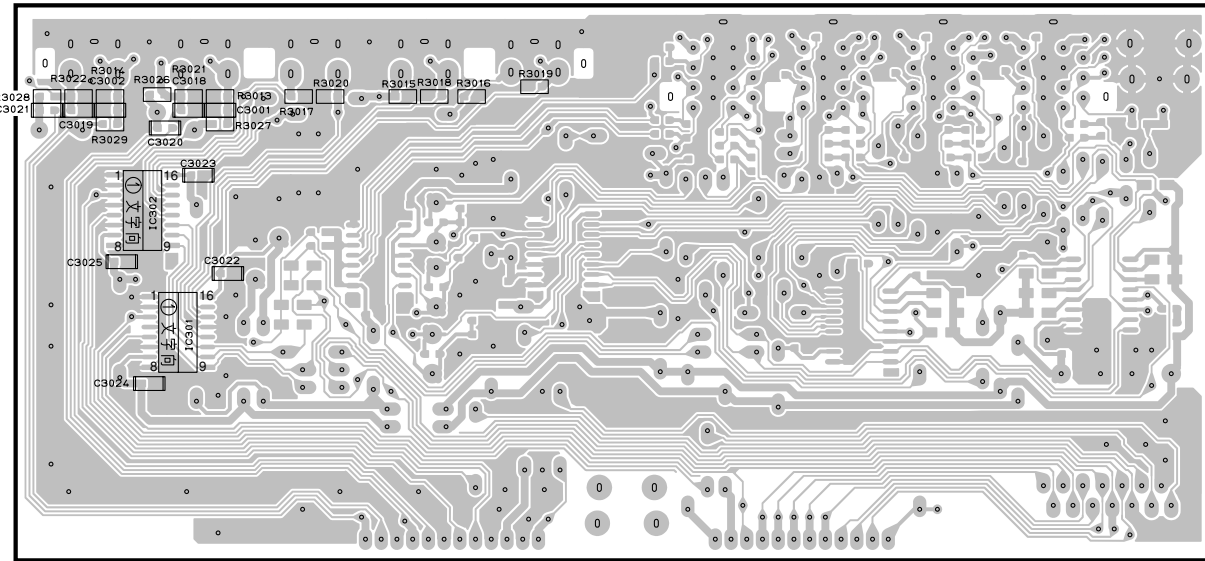

VIDEO (2) P.C.B. (Side B)

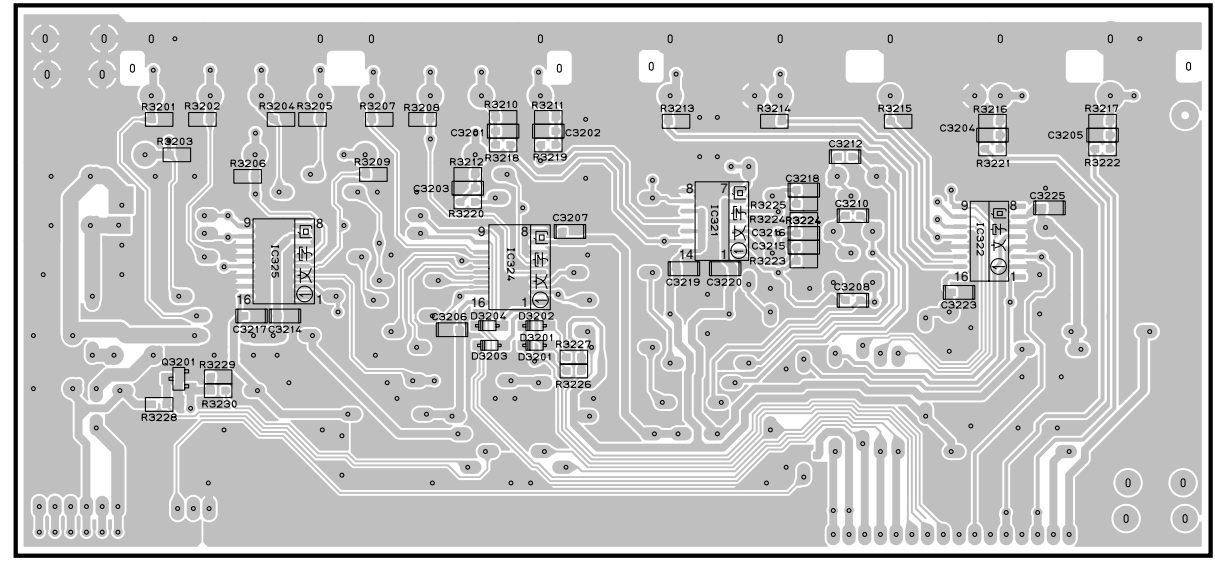

• Semiconductor Location

Ref no.	Location
D3201	H4
D3202	H4
D3203	G4
D3204	G4
IC301	A4
IC302	A4
IC321	H4
IC322	I4
IC324	G4
IC325	G4
Q3201	F4

• Semiconductor Location

Ref no.	Location
D4909	C4
D4910	C3
D4912	C4
D4913	C4
D4914	C4
D4915	C4
D4916	C4
D4917	C5
D4918	C5
D4919	C5
D4920	C4
D4921	C4
D4922	C4
D4923	C5
D4924	C5
D4925	C5
D4926	C5
D4927	C6
D4928	C6
D4929	C6
D4930	C6
D4931	C6
D4932	C5
D4933	E3
D4934	E3
D4936	E4
D4937	E4
IC902	C4
IC903	D4
IC904	D5
IC905	D3
IC906	D5
IC907	D5
IC908	E5
IC909	E4
IC910	E4
IC911	E4
Q4902	H4
Q4903	H4
Q4904	G4
Q4905	H6
Q4906	G6

HDMI P.C.B. (Side A)

T, G, E models

HDMI P.C.B. (Side B)

1
2
3
4
5
6
7

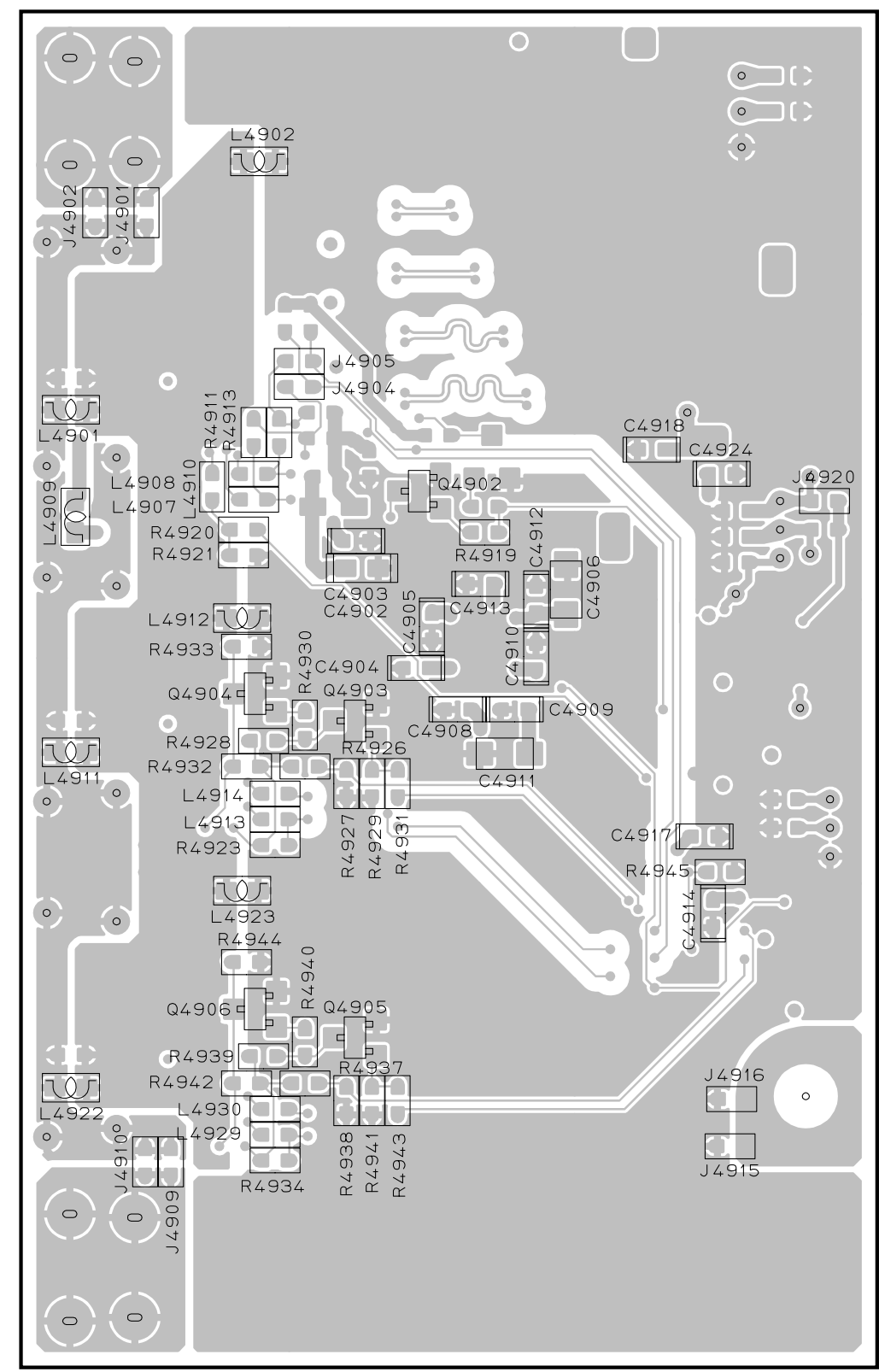
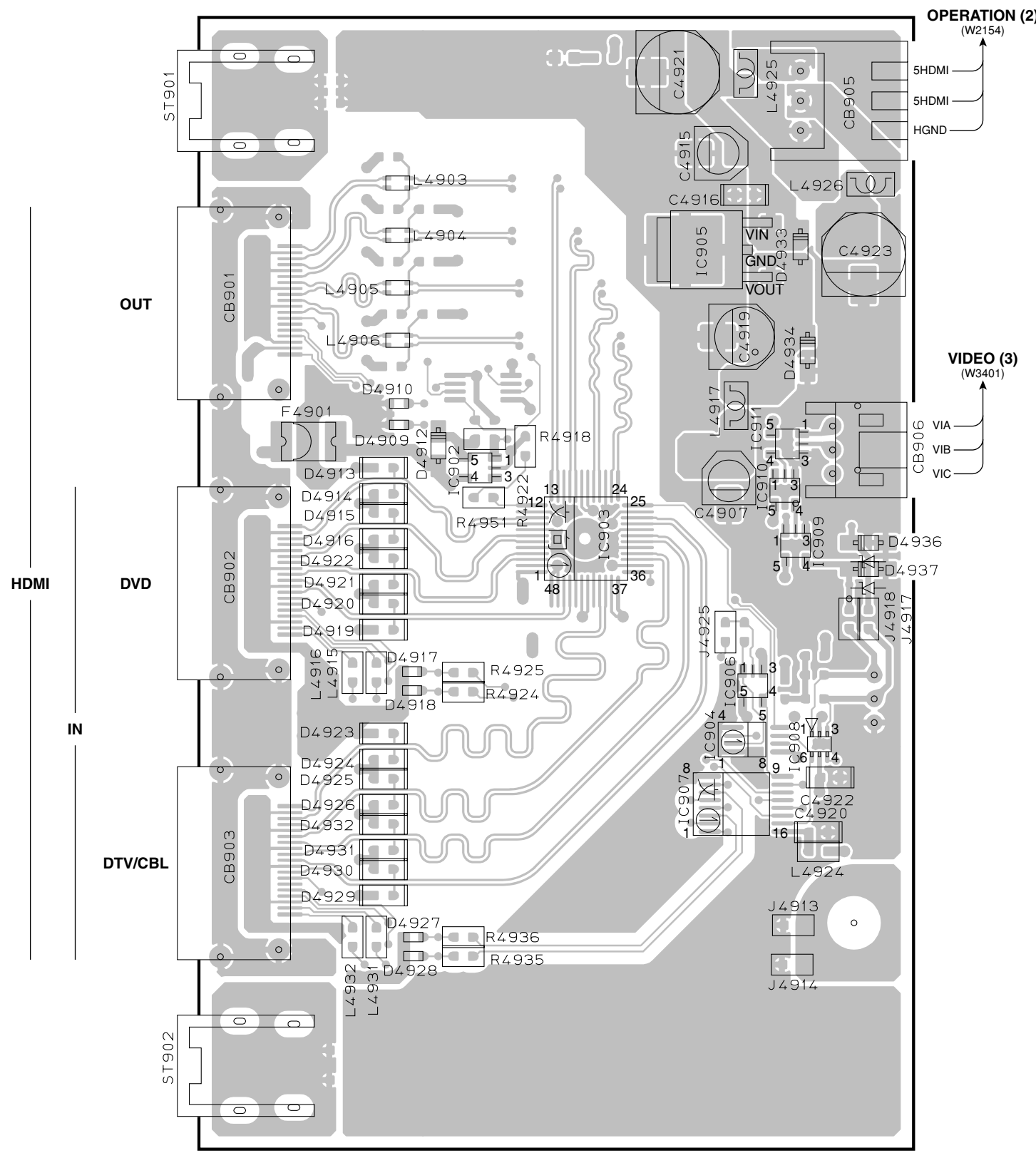

SCHEMATIC DIAGRAMS
DSP 1/6

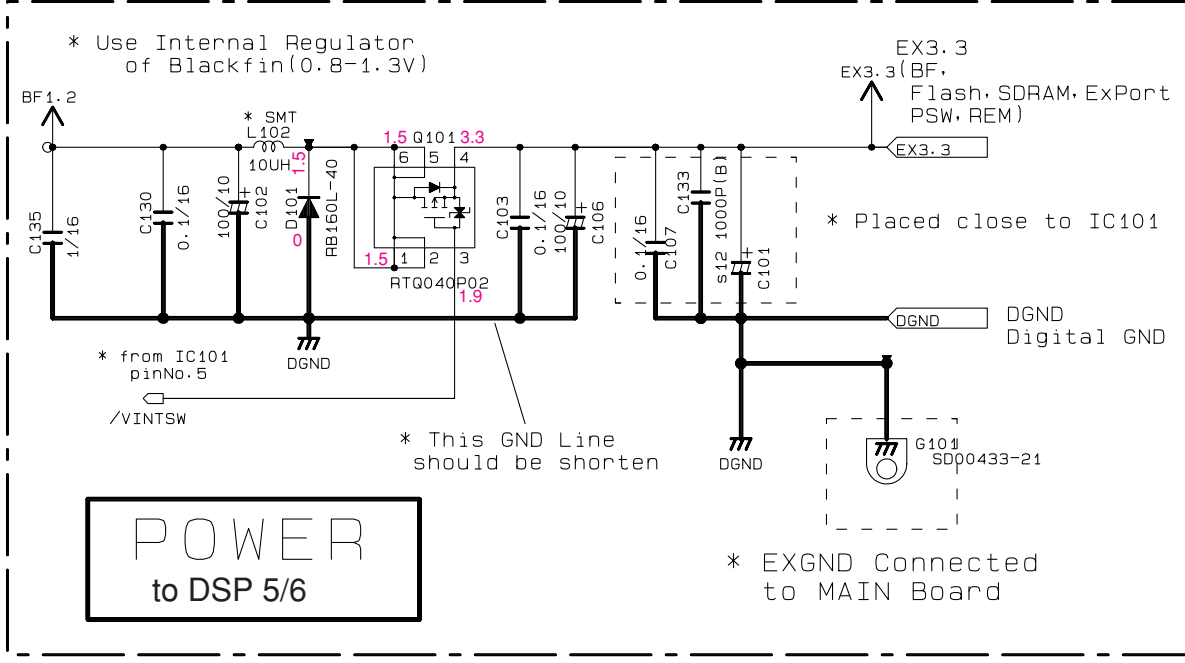
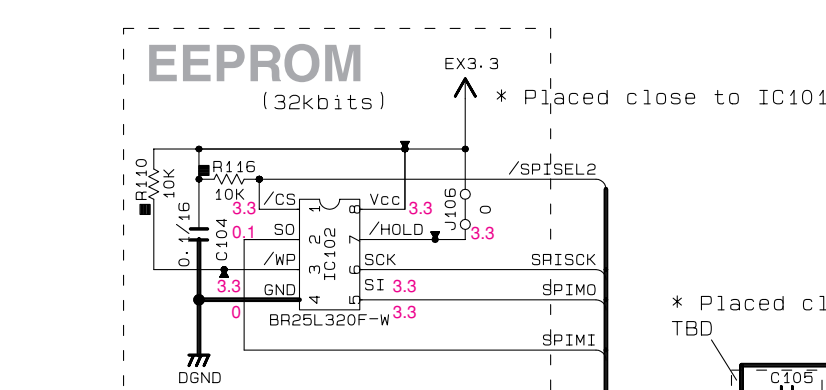
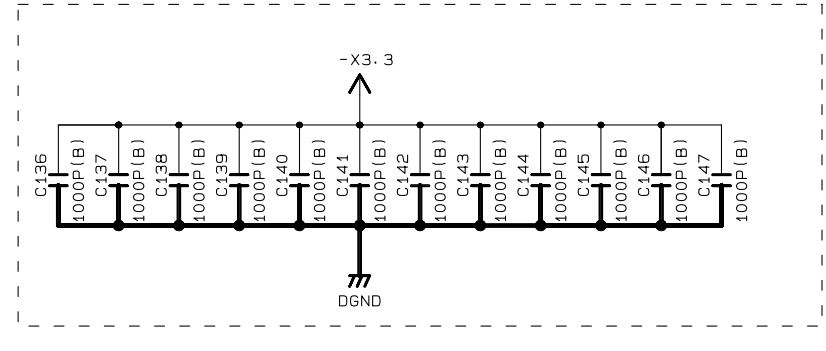
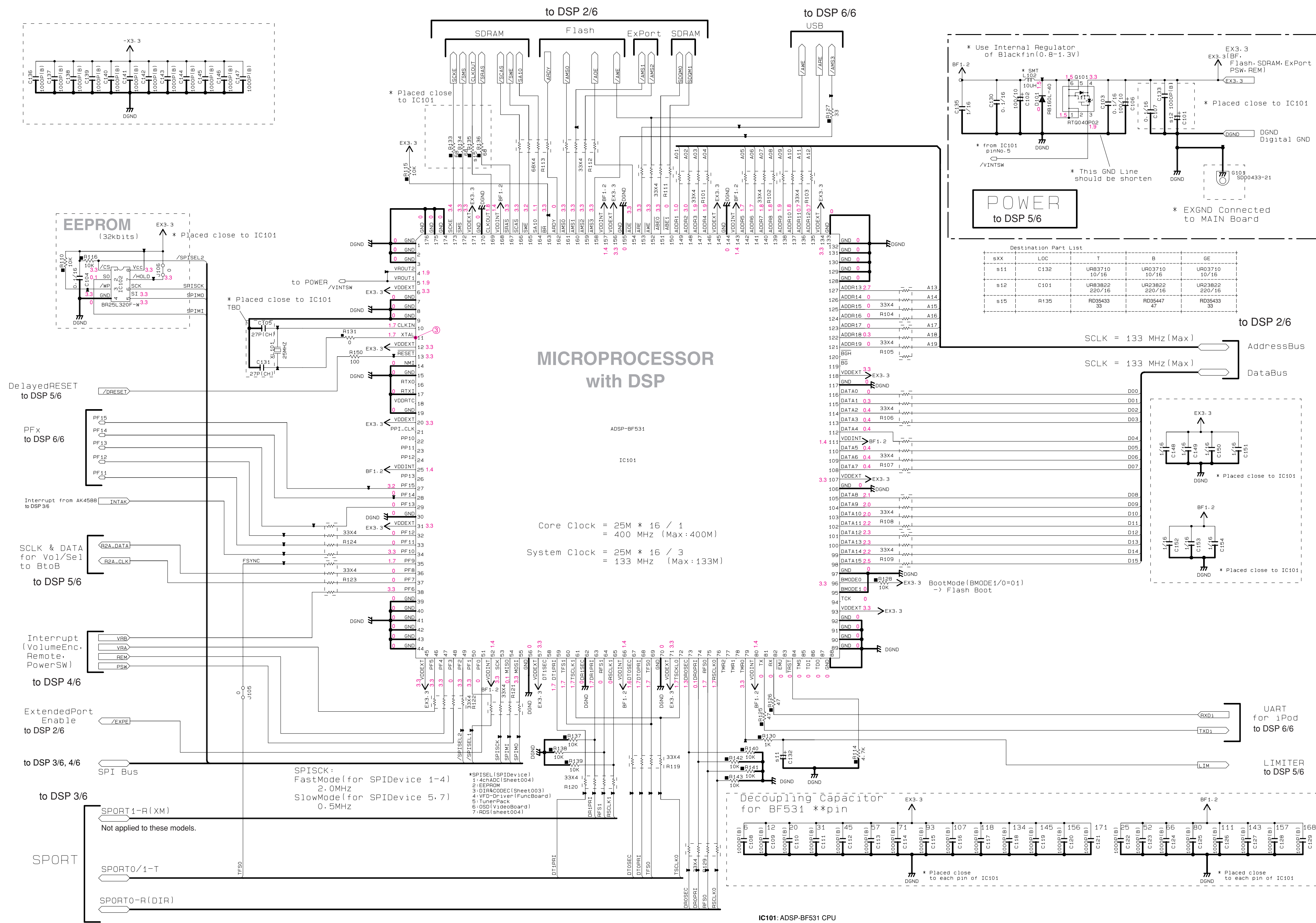

Delayed RESET to DSP 5/6

PFX to DSP 6/6

Interrupt from AK4588 to DSP 3/6

SCLK & DATA for Vo1/Se1 to BtoB to DSP 5/6

Interrupt (VolumeEnc, Remote, PowerSw) to DSP 4/6

ExtendedPort Enable to DSP 2/6

to DSP 3/6, 4/6

to DSP 3/6

SPORT

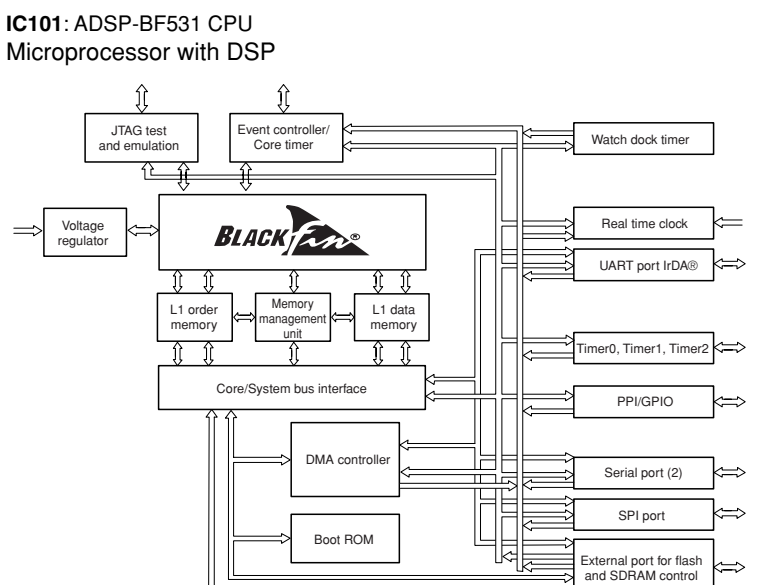
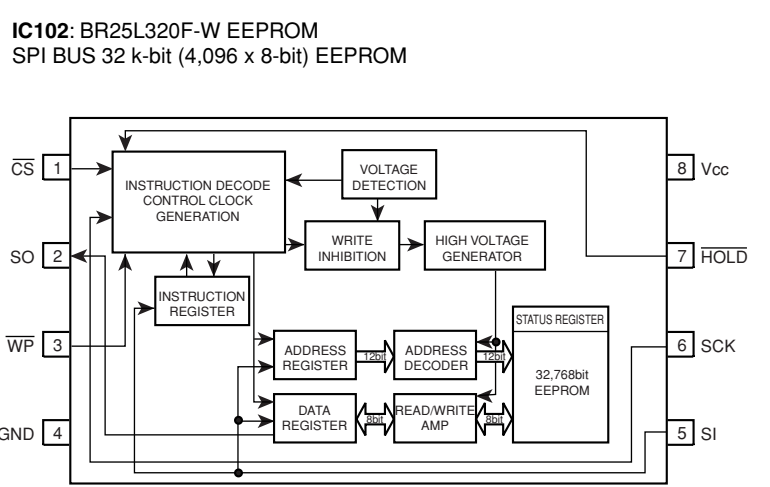
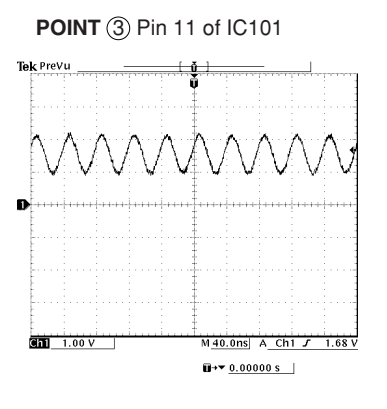

NOTICE (mod1)

(J)..... JAPAN
(U)..... U.S.A
(C)..... CANADA
(R)..... GENERAL
(T)..... CHINA
(K)..... KOREA
(A)..... AUSTRALIA
(B)..... BRITISH
(G)..... EUROPE
(L)..... SINGAPORE
(E)..... SOUTH EUROPE
(V)..... TAIWAN

* All voltages are measured with a 10MΩ/V DC electronic voltmeter.
* Components having special characteristics are marked Ⓢ, and must be replaced with parts having specifications equal to those originally installed.
* Schematic diagram is subject to change without notice.

DSP 2/6

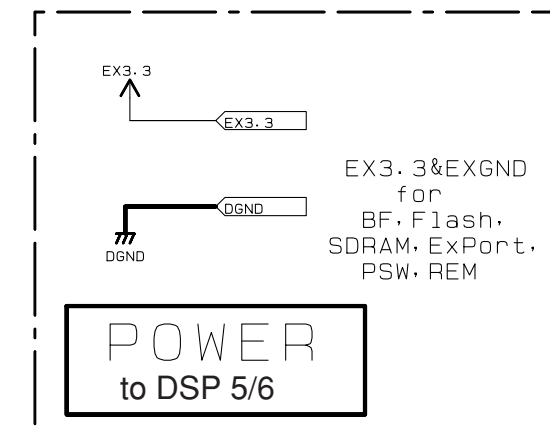
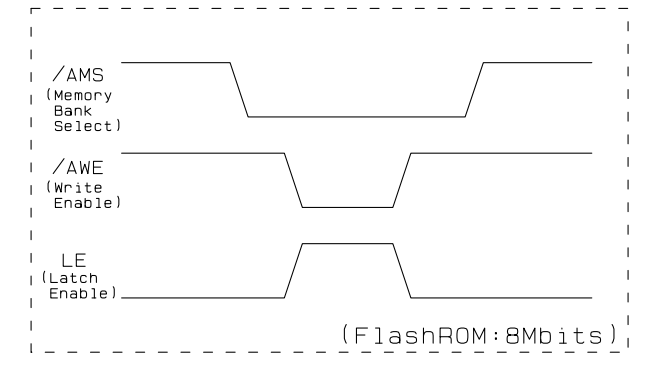
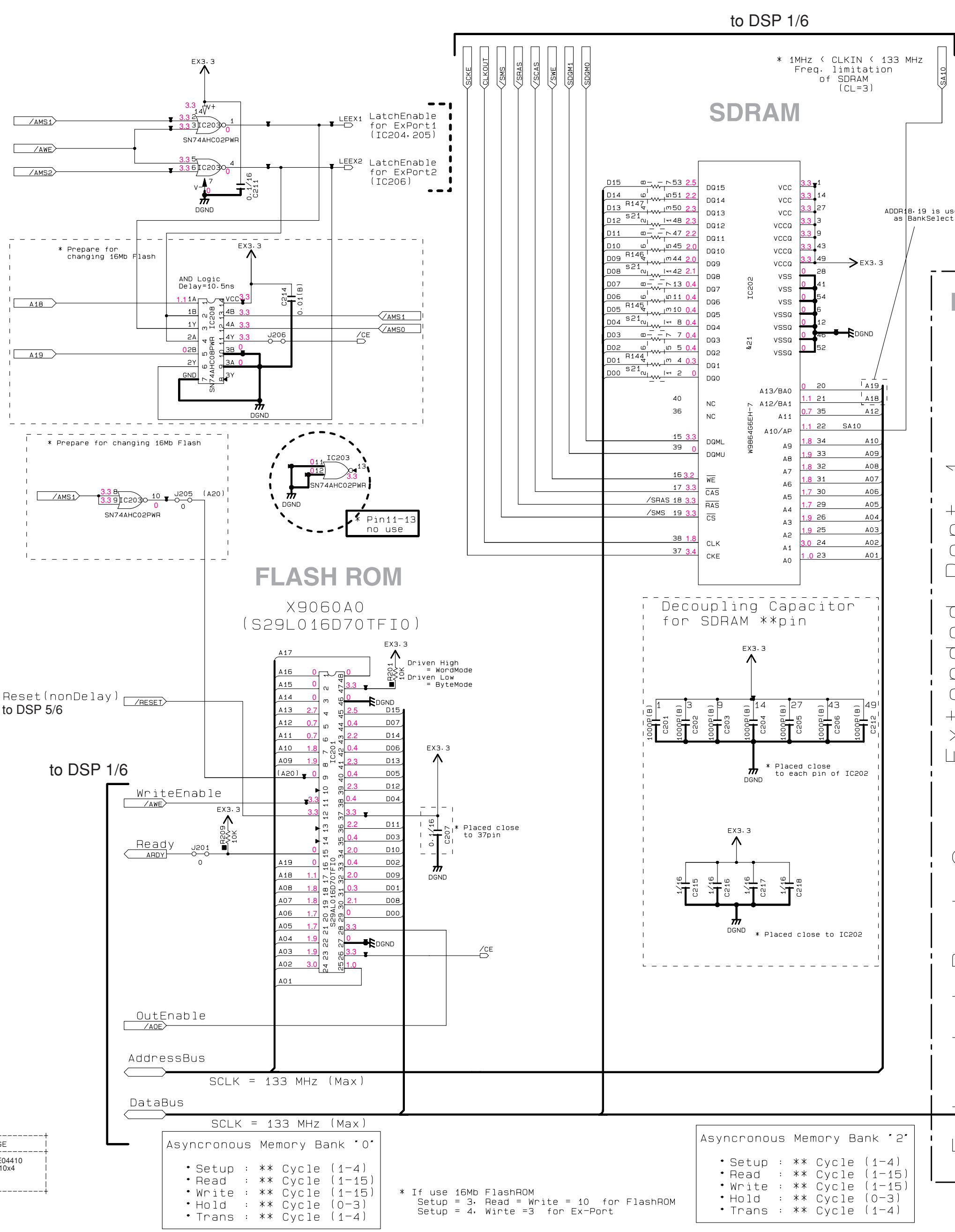

NOTICE (model)

(J)..... JAPAN
(U)..... U.S.A
(C)..... CANADA
(R)..... GENERAL
(T)..... CHINA
(K)..... KOREA
(A)..... AUSTRALIA
(B)..... BRITISH
(G)..... EUROPE
(L)..... SINGAPORE
(V)..... SOUTH EUROPE
(Y)..... TAIWAN

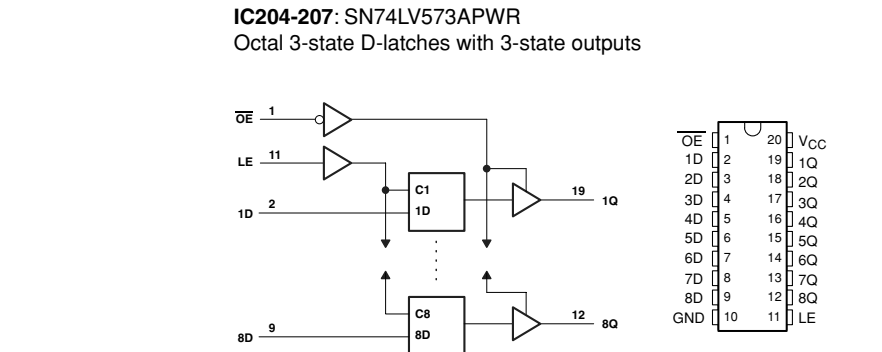
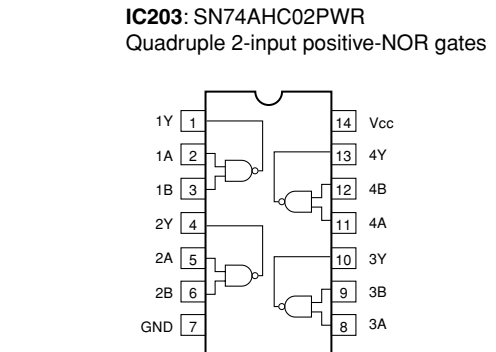
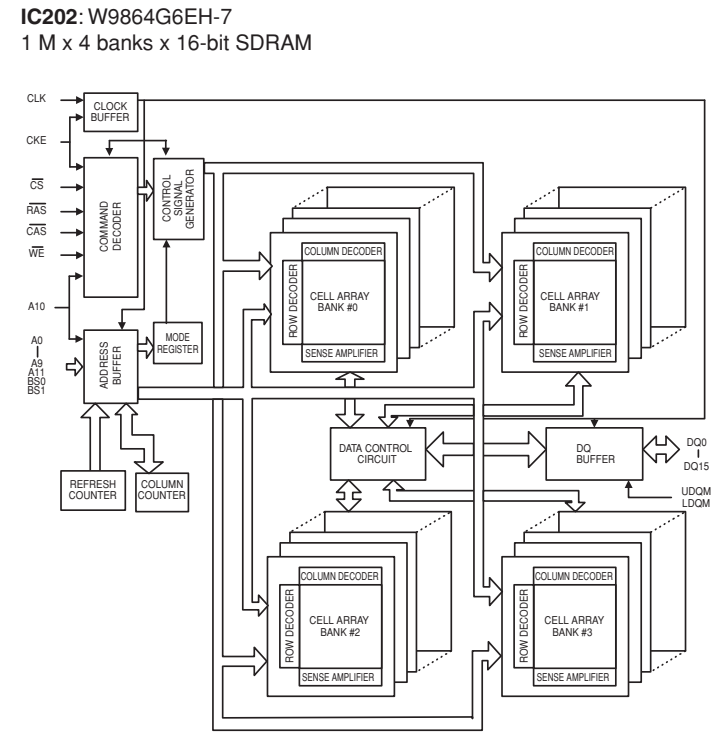
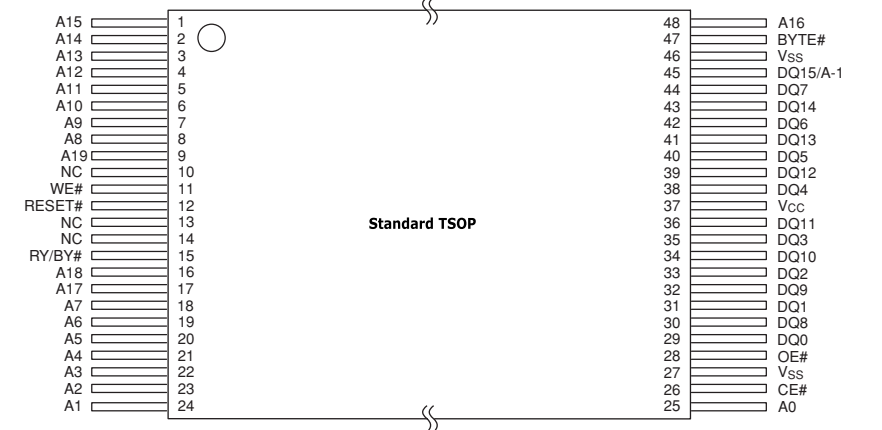
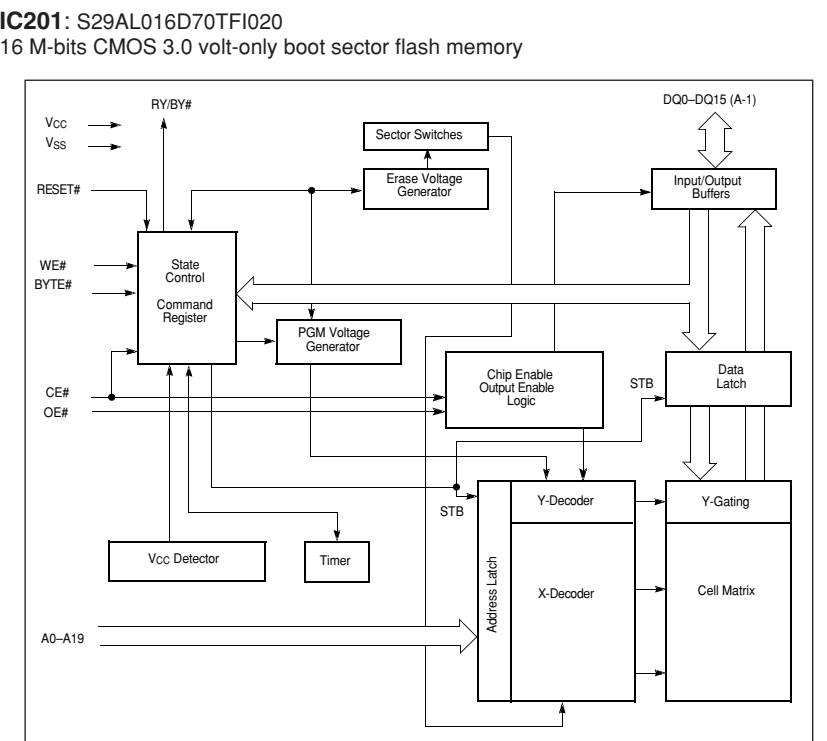
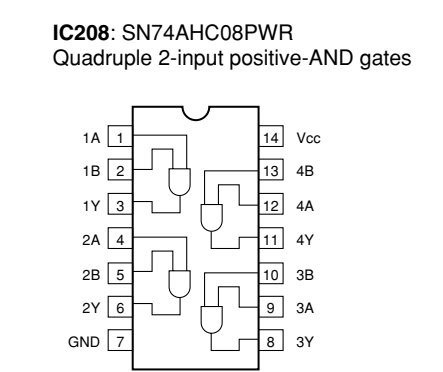
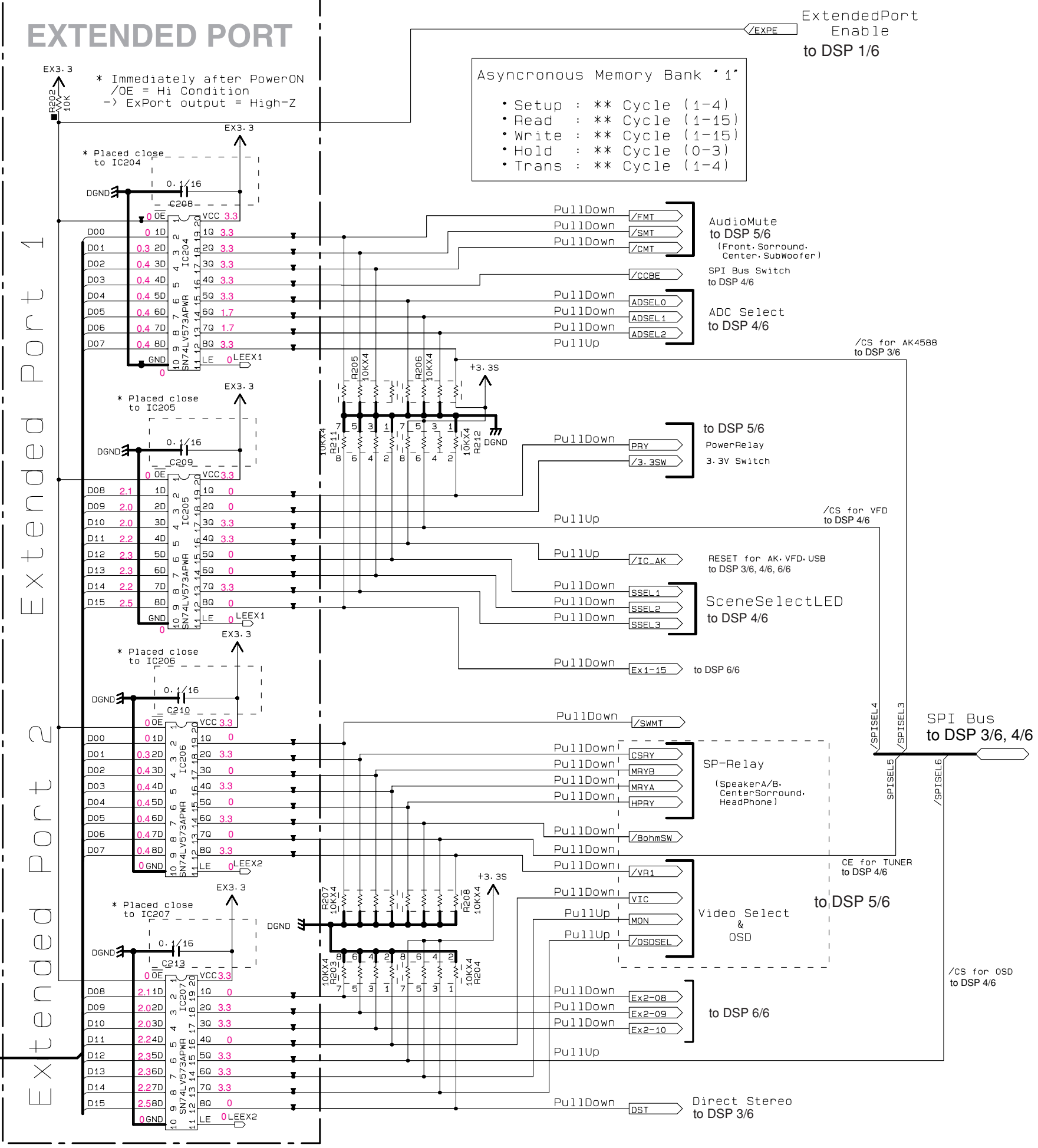

* All voltages are measured with a 10M Ω DC electronic voltmeter.
* Components having special characteristics are marked 1, and must be replaced with parts having specifications equal to those originally installed.
* Schematic diagram is subject to change without notice.

DSP 3/6

NOTICE (model)

(J)..... JAPAN
 (U)..... U.S.A
 (C)..... CANADA
 (R)..... GENERAL
 (T)..... CHINA
 (K)..... KOREA
 (A)..... AUSTRALIA
 (B)..... BRITISH
 (G)..... EUROPE
 (L)..... SINGAPORE
 (E)..... SOUTH EUROPE
 (V)..... TAIWAN

Destination Part List

93X	LOC	T	S	SE
931	C308 C348 C350	UR83710 10/16	UR83710 10/16	UR83710 10/16
932	C305	UR23810 47/16	UR23810 100/16	UR23810 100/16
933	C314	UR84722 22/25	UR84722 22/25	UR84722 22/25
934	DAB	X	O	X

Page 80 C4
to DAB_W3601 (B model)

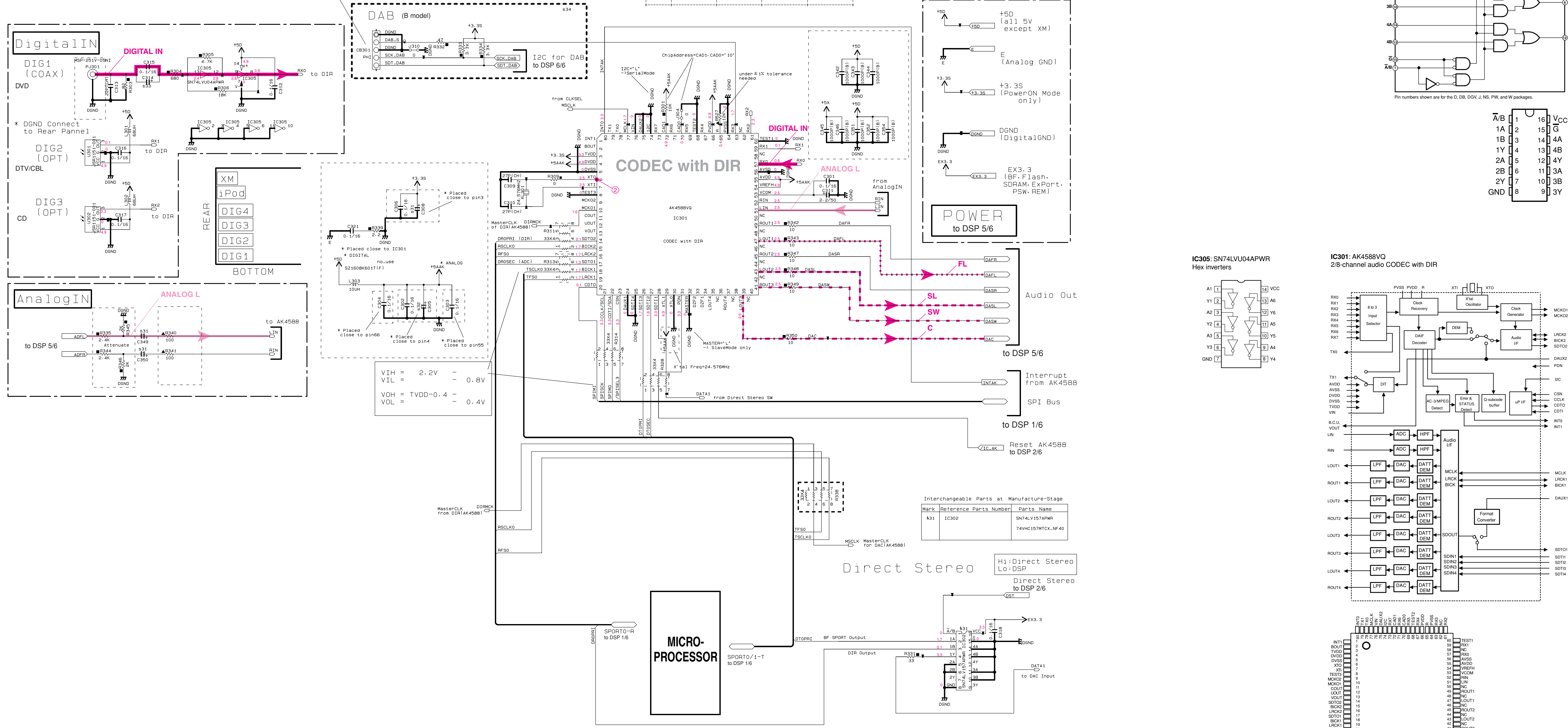

VIH = 2.2V - 0.8V
 VIL = TVDD - 0.4 - 0.4V

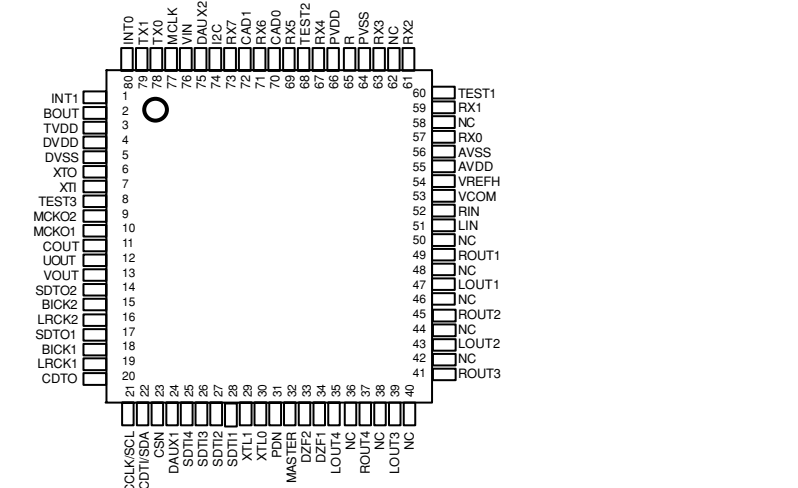
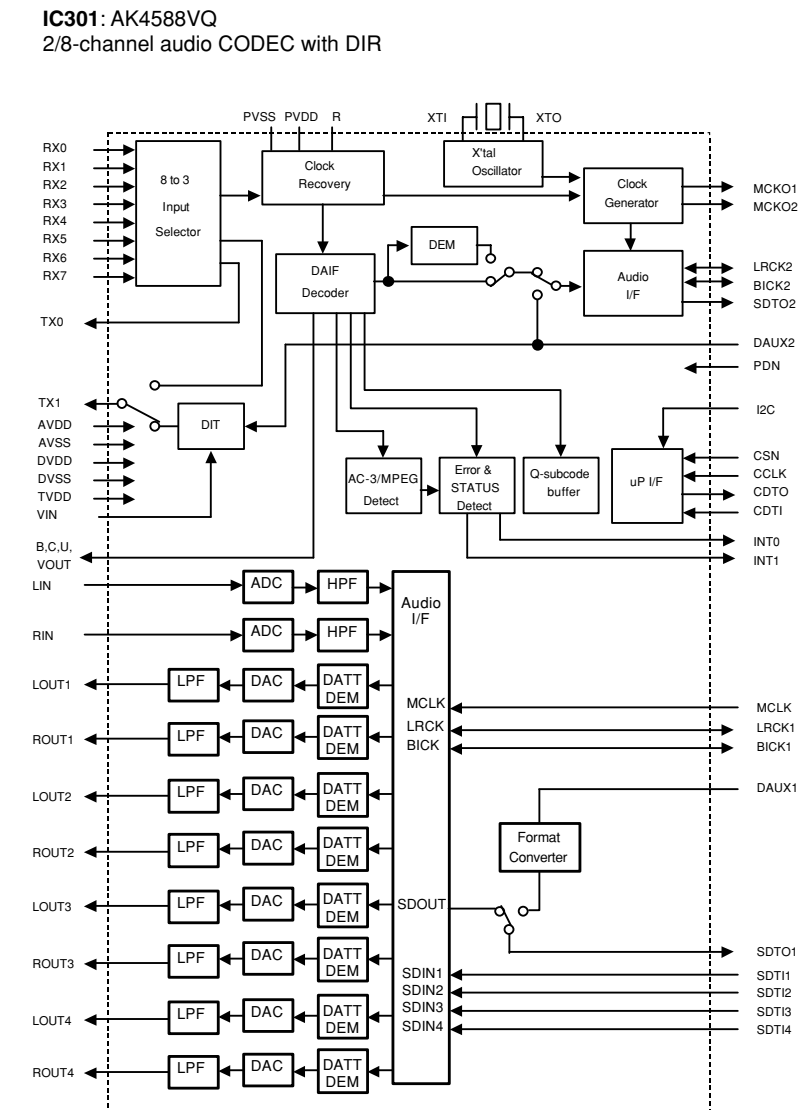
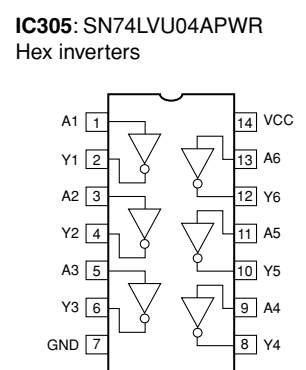
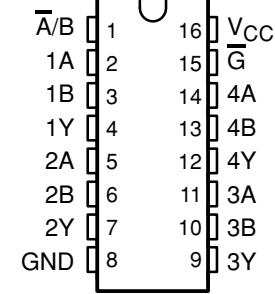
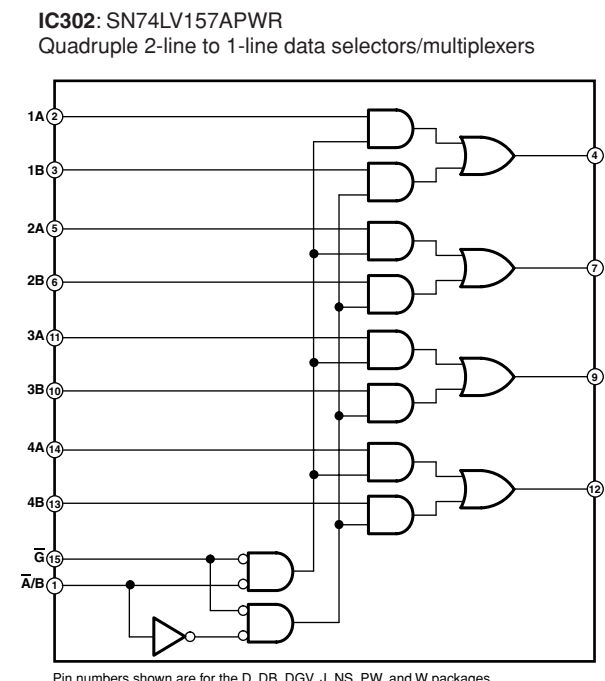
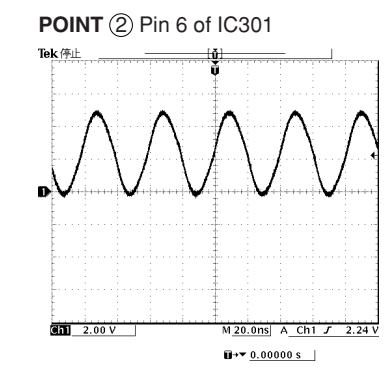

* All voltages are measured with a 10MΩ/V DC electronic voltmeter.
 * Components having special characteristics are marked with a triangle and must be replaced with parts having specifications equal to those originally installed.
 * Schematic diagram is subject to change without notice.

DSP 4/6

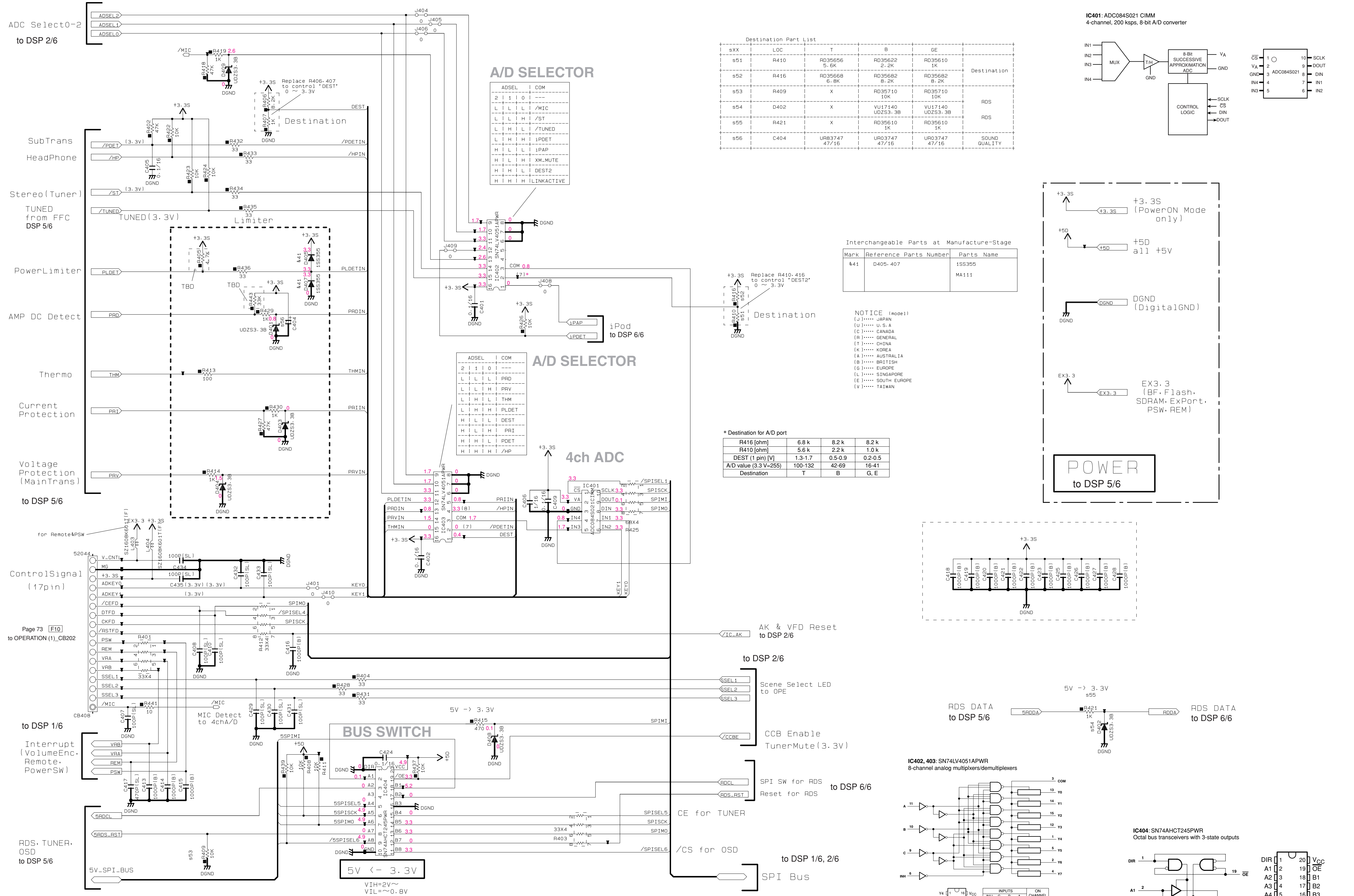

Destination Part List

sXX	LOC	T	B	GE	Destination
s51	R410	R035656 5.6K	R035622 2.2K	R035610 1K	
s52	R416	R035668 6.8K	R035682 8.2K	R035626 8.2K	
s53	R409	X	R035710 10K	R035710 10K	
s54	D402	X	VU17140 UDZ53.3B	VU17140 UDZ53.3B	RDS
s55	R421	X	R035610 1K	R035610 1K	RDS
s56	C404	UR03747 47/16	UR03747 47/16	UR03747 47/16	SOUND QUALITY

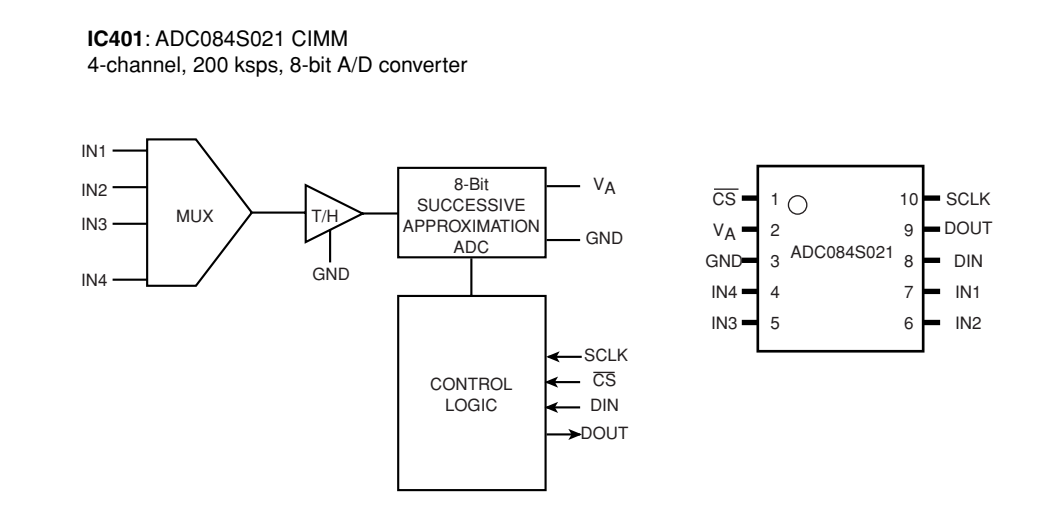

Interchangeable Parts at Manufacture-Stage

Mark	Reference Parts Number	Parts Name
441	D405-407	1SS355 MA111

NOTICE (model)
 (J)..... JAPAN
 (U)..... U.S.A
 (C)..... CANADA
 (R)..... GENERAL
 (T)..... CHINA
 (K)..... KOREA
 (A)..... AUSTRALIA
 (B)..... BRITISH
 (G)..... EUROPE
 (L)..... SINGAPORE
 (E)..... SOUTH EUROPE
 (V)..... TAIWAN

* Destination for A/D port

	6.8 k	8.2 k	8.2 k
R416 [ohm]	6.8 k	8.2 k	8.2 k
R410 [ohm]	5.6 k	2.2 k	1.0 k
DEST (1 pin) [V]	1.3-1.7	0.5-0.9	0.2-0.5
A/D value (3.3V-255)	100-132	42-69	16-41
Destination	T	B	G, E

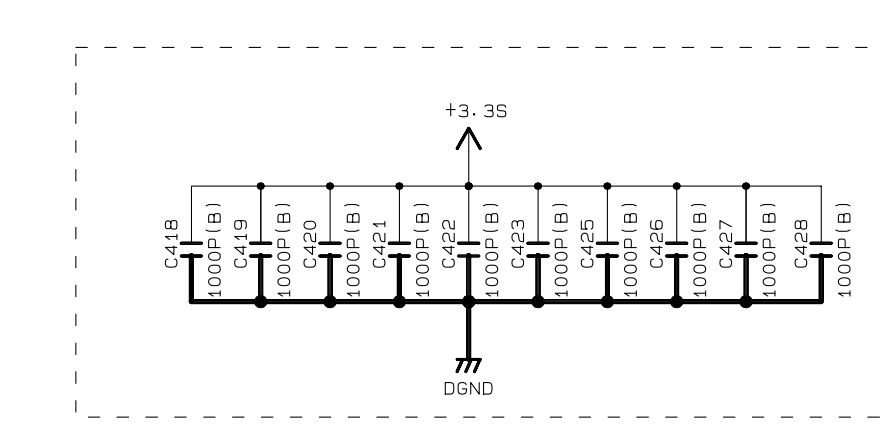

* All voltages are measured with a 10MΩ/V DC electronic voltmeter.
 * Components having special characteristics are marked Δ , and must be replaced with parts having specifications equal to those originally installed.
 * Schematic diagram is subject to change without notice.

DSP 6/6

IC601: ISP1362BD
Single-chip universal serial bus on-the-go controller

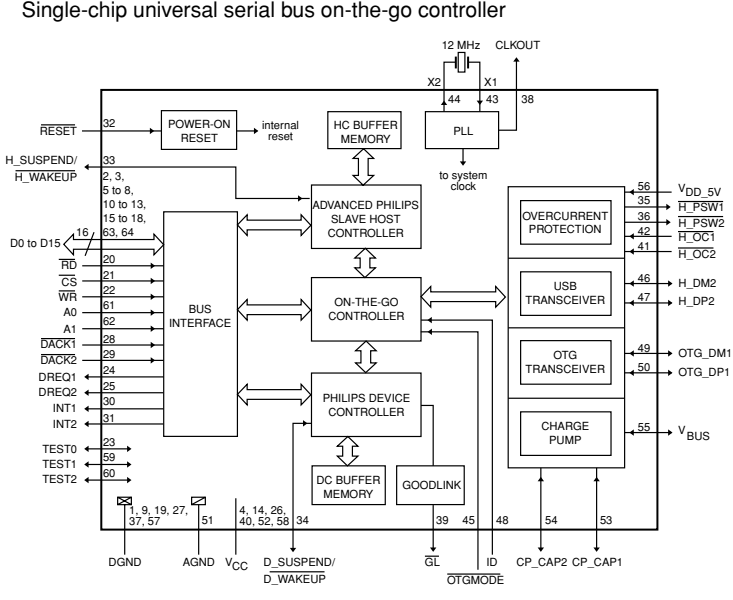

IC602: MIC2026-2BM
Dual-channel power distribution switch

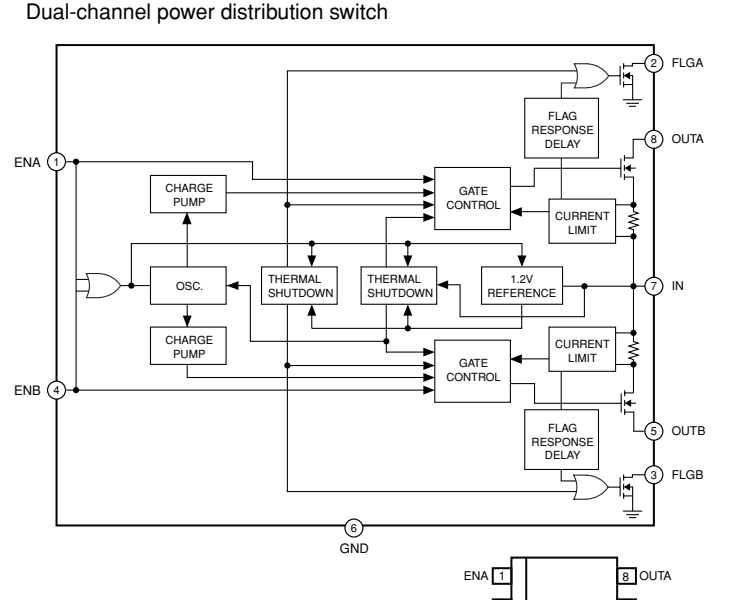

POINT (A2) XL601 (Pin 43 of IC601)

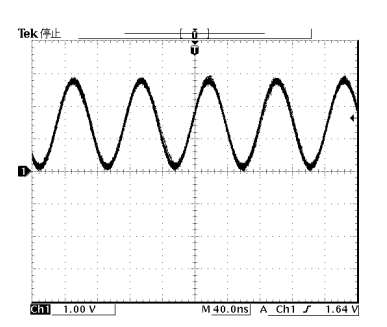

Destination Part List

sXX	LOC	T	B	GE
	iPod	X	O	X
s61	RE52	X		
s62	R603	X		
s63	J611	X		
s64	R602	X		
s65	J606	X		
s66	R608	X		
s70	R656	X		
s71	C609	X		

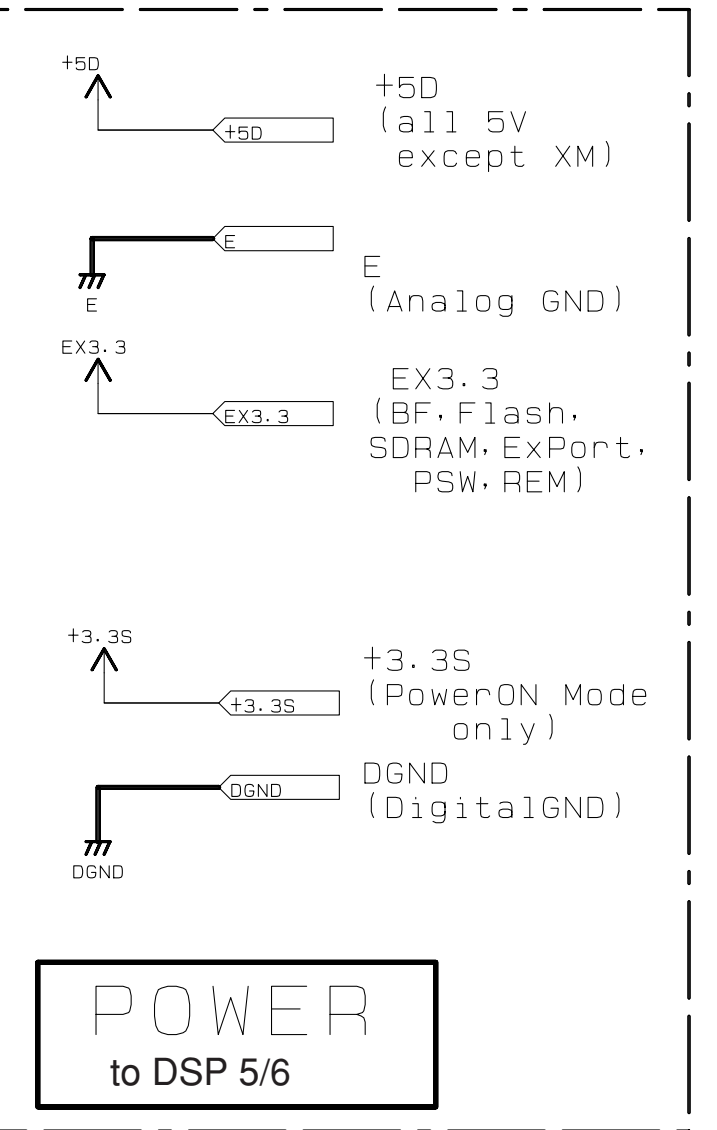

NOTICE (model)
 (J) JAPAN
 (U) U.S.A
 (C) CANADA
 (R) GENERAL
 (T) CHINA
 (K) KOREA
 (A) AUSTRALIA
 (B) BRITISH
 (E) EUROPE
 (L) SINGAPORE
 (V) SOUTH EUROPE
 (I) TAIWAN

Interchangeable Parts at Manufacture-Stage

Mark	Reference Parts Number	Parts Name
661	D602	1SS355
		MA111

iPod (B model)

18pin:Rx for uCOM
14pin:Tx for uCOM

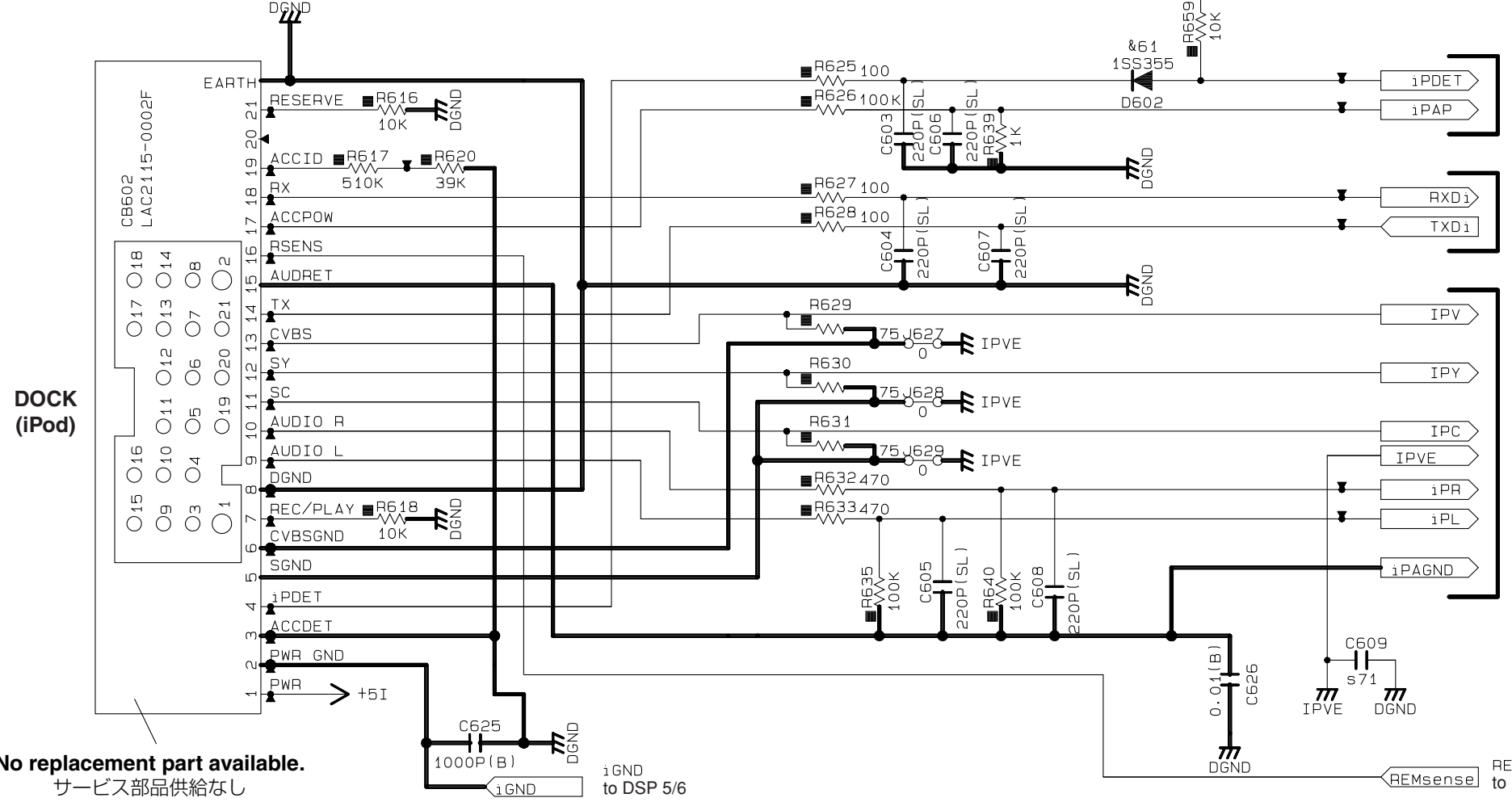

No replacement part available.
サービス部品供給なし

IC604: TC7SZ08FU
2-input OR gate

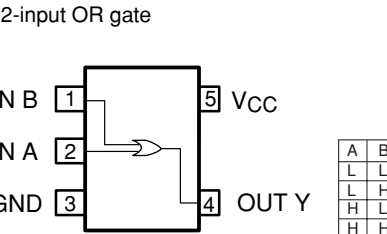

IC603: SN74CBTLV16210GR
Low voltage20-bit FET bus switch

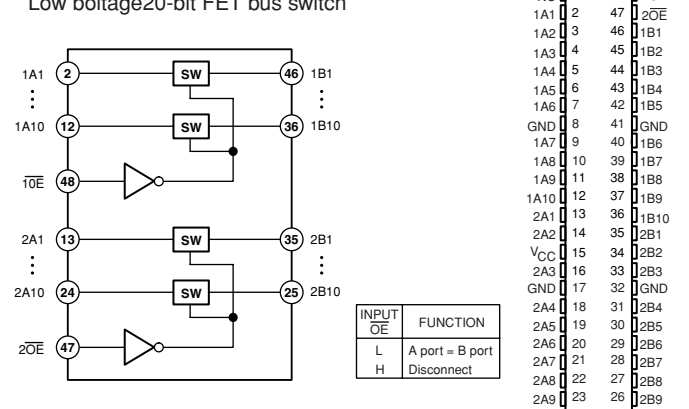

Destination Circuit

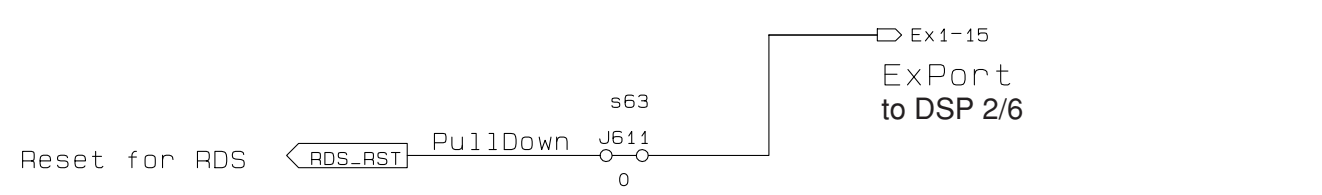
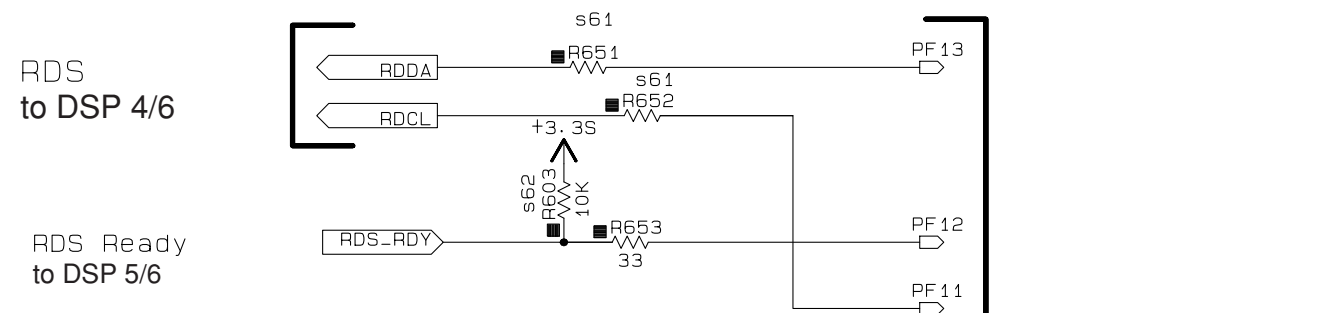
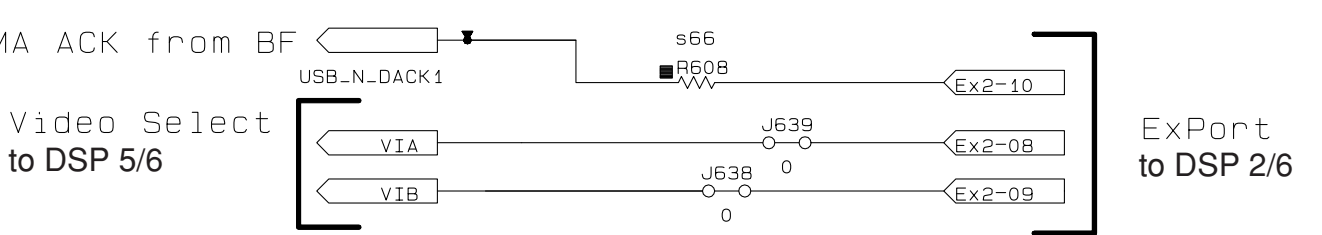
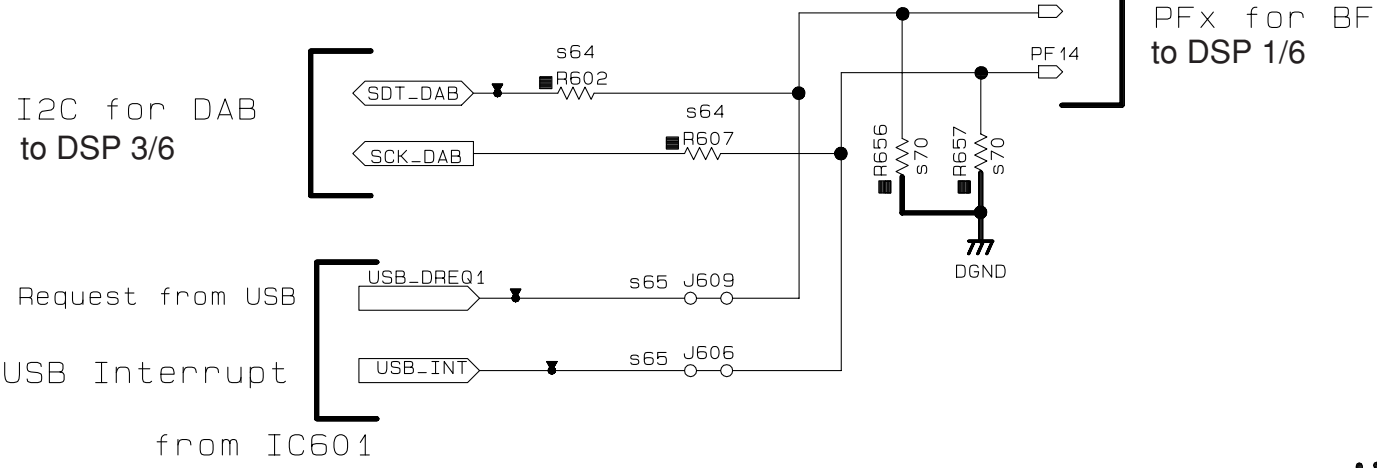

USB (T, G, E models)

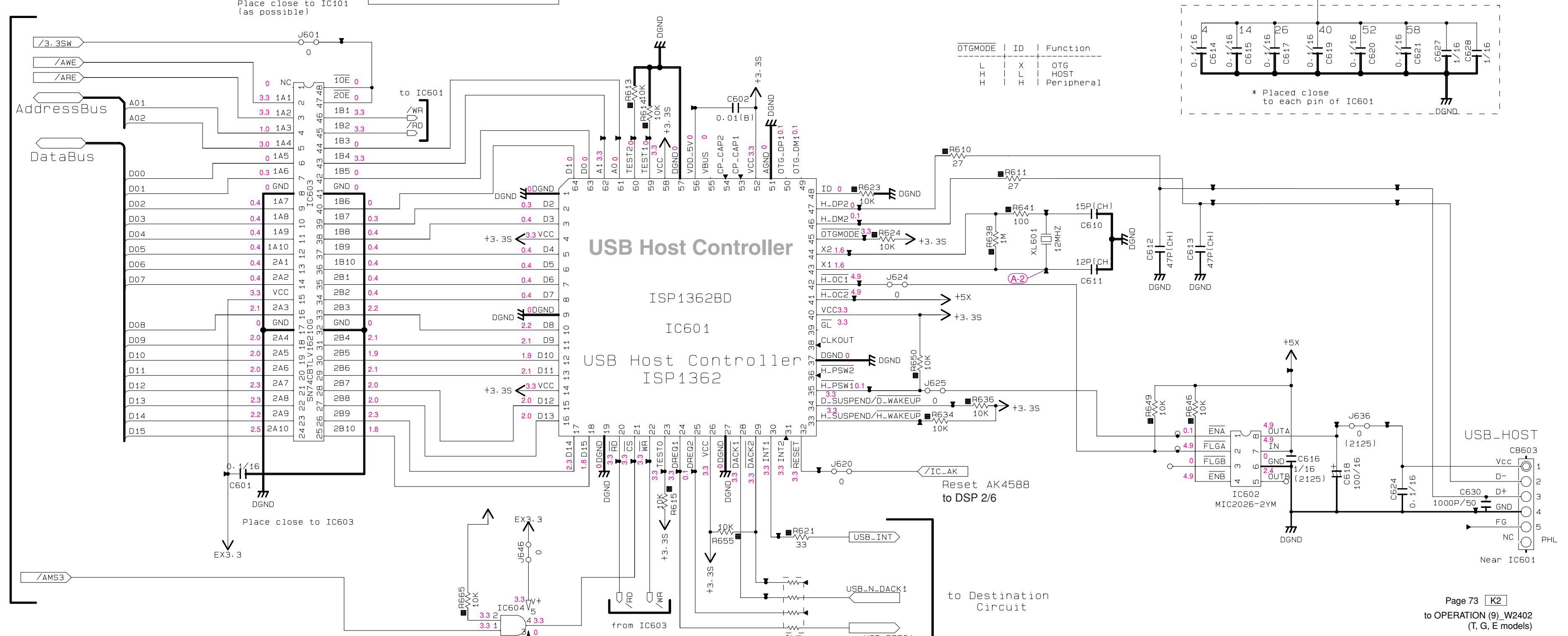

DTGMODE	ID	Function
H	X	DTG HOST
L	L	DTG Peripheral

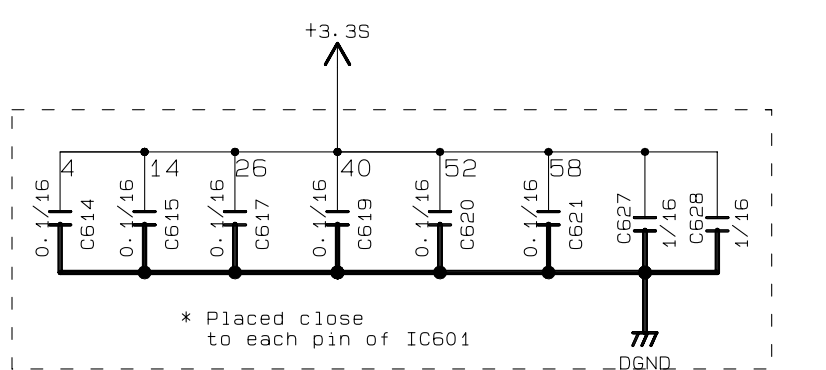

* All voltages are measured with a 10MΩ/V DC electronic voltmeter.
 * Components having special characteristics are marked 1 and must be replaced with parts having specifications equal to those originally installed.
 * Schematic diagram is subject to change without notice.

OPERATION 1/2

REMARKS	PARTS NAME
NO MARK	CARBON FILM RESISTOR (P=5)
⊠	CARBON FILM RESISTOR (P=10)
△	METAL OXIDE FILM RESISTOR
▴	METAL FILM RESISTOR
⊞	METAL PLATE RESISTOR
▩	FIRE PROOF CARBON FILM RESISTOR
⊞	CEMENT MOLDED RESISTOR
⊞	SEMI VARIABLE RESISTOR
⊞	CHIP RESISTOR

REMARKS	PARTS NAME
NO MARK	ELECTROLYTIC CAPACITOR
⊗	TANTALUM CAPACITOR
NO MARK	CERAMIC CAPACITOR
●	CERAMIC TUBULAR CAPACITOR
○	POLYESTER FILM CAPACITOR
○	POLYSTYRENE FILM CAPACITOR
⊖	MICA CAPACITOR
⊖	POLYPROPYLENE FILM CAPACITOR
⊖	SEMICONDUCTIVE CERAMIC CAPACITOR
⊖	POLYPHENYLENE SULFIDE FILM CAPACITOR

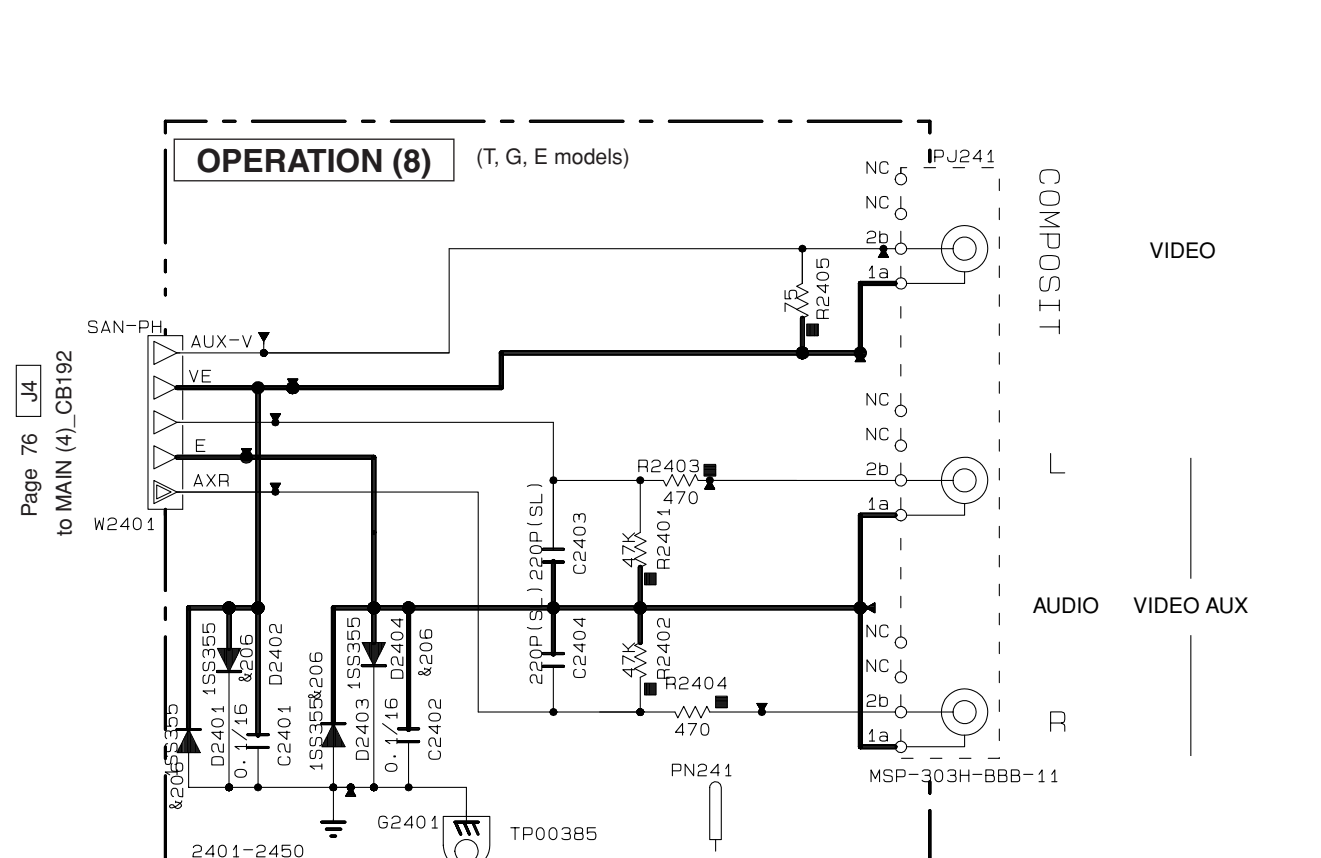
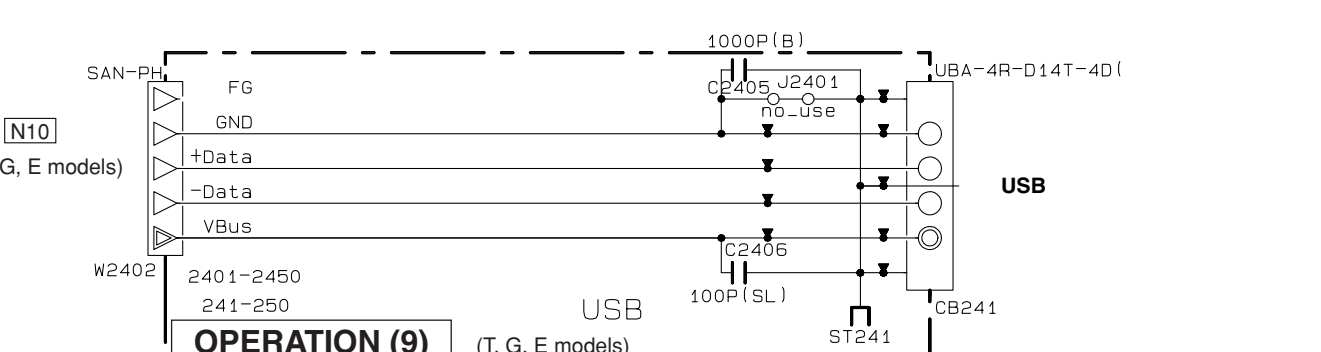
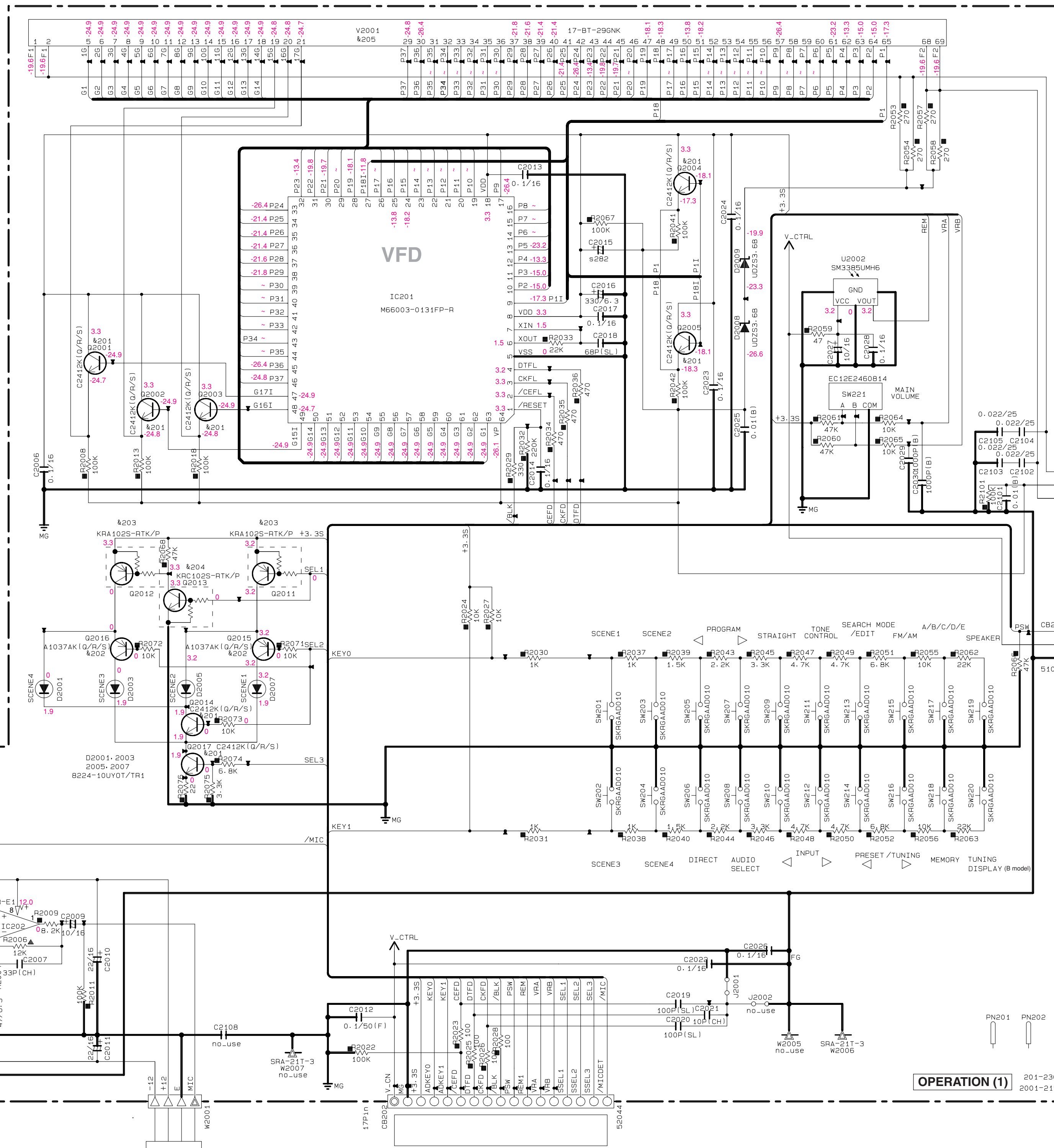
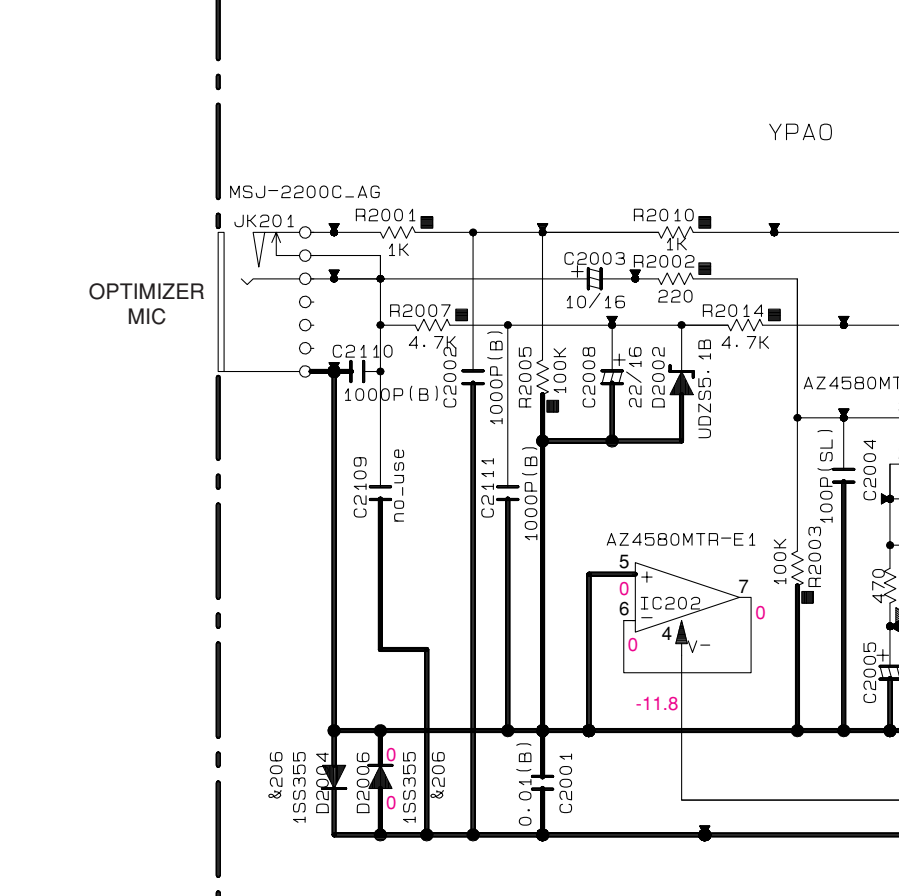
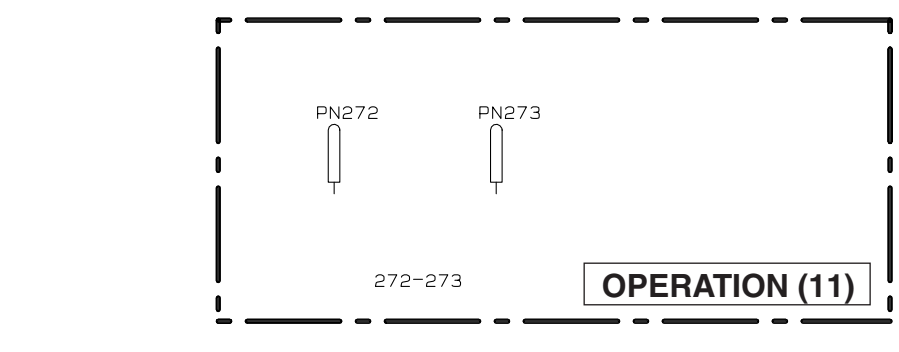
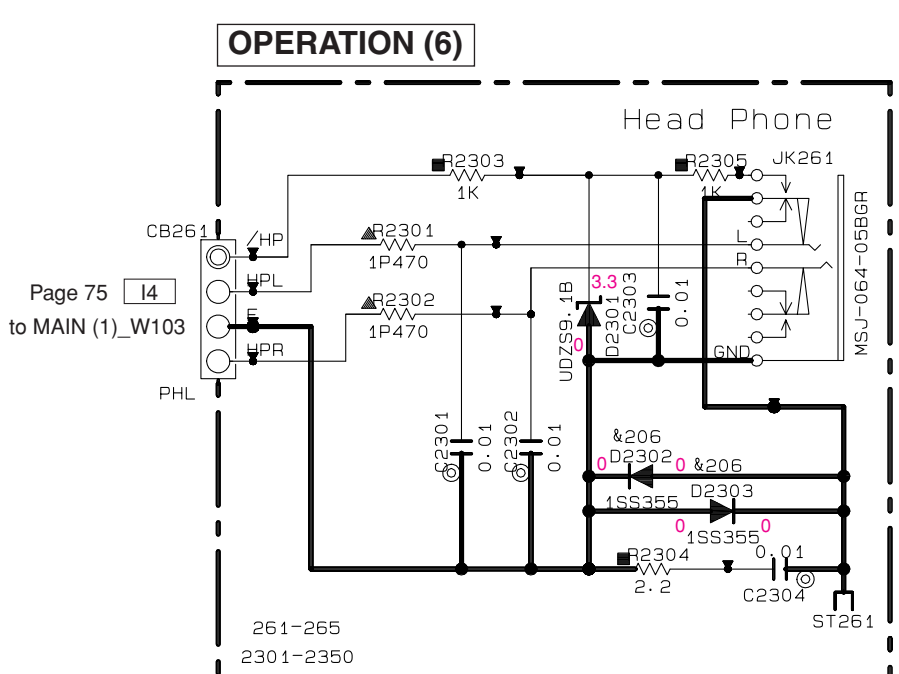

Mark	Reference Parts Number	Parts Name
&201	G2001-2005, 2014-2017	2SC2412K(G/R/S)
&202	G2015, 2016	2SA1037AK(G/R/S)
&203	G2011, 2012	DTA114EKA
&204	G2013	DTC114EKA
&205	V2001	KRC1025-RTK/P
&206	D2004, 2006, 2302, 2303	1SS335
	2401-2404, 2351-2354	MA111

Destination Part List	sXX	LOC	T	B	GE
OPERATION (7) P.C.B.			X	O	X
OPERATION (8) P.C.B.			O	X	O
OPERATION (9) P.C.B.			O	X	O

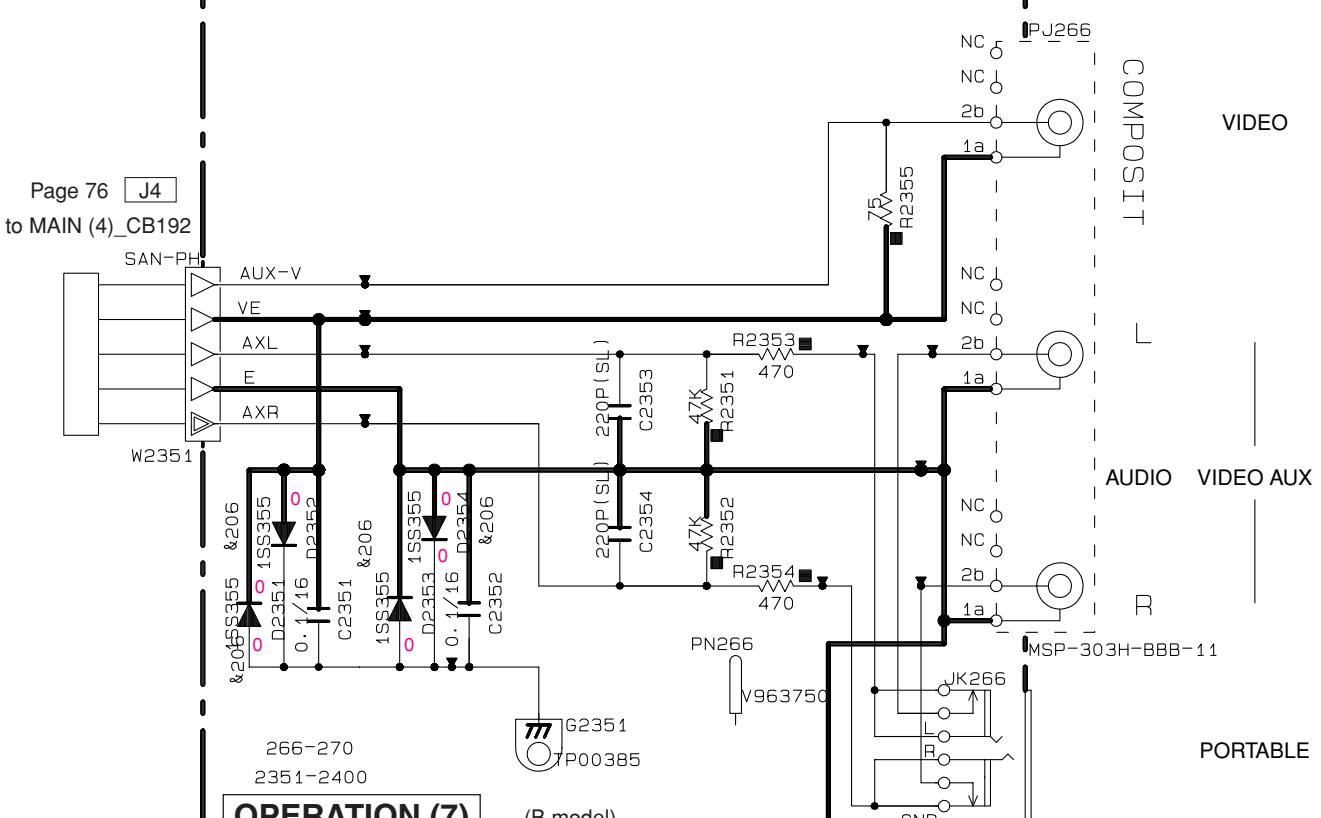

NOTICE (model1)
 (J)..... JAPAN
 (U)..... U. S. A
 (C)..... CANADA
 (R)..... GENERAL
 (T)..... CHINA
 (K)..... KOREA
 (A)..... AUSTRALIA
 (B)..... BRITISH
 (G)..... EUROPE
 (L)..... SINGAPORE
 (E)..... SOUTH EUROPE
 (V)..... TAIWAN

Page 76 [J4] to MAIN (4)_CB191
 Page 70 [B7] to DSP_CB408

* All voltages are measured with a 10MΩ/V DC electronic voltmeter.
 * Components having special characteristics are marked ⊠, and must be replaced with parts having specifications equal to those originally installed.
 * Schematic diagram is subject to change without notice.

VIDEO 1/2

Page 71 [B7] to DSP_CB504

Page 76 [K4] to MAIN (4)_CB193

Page 79 [M6] to HDMI_CB906 (T, G, E models)

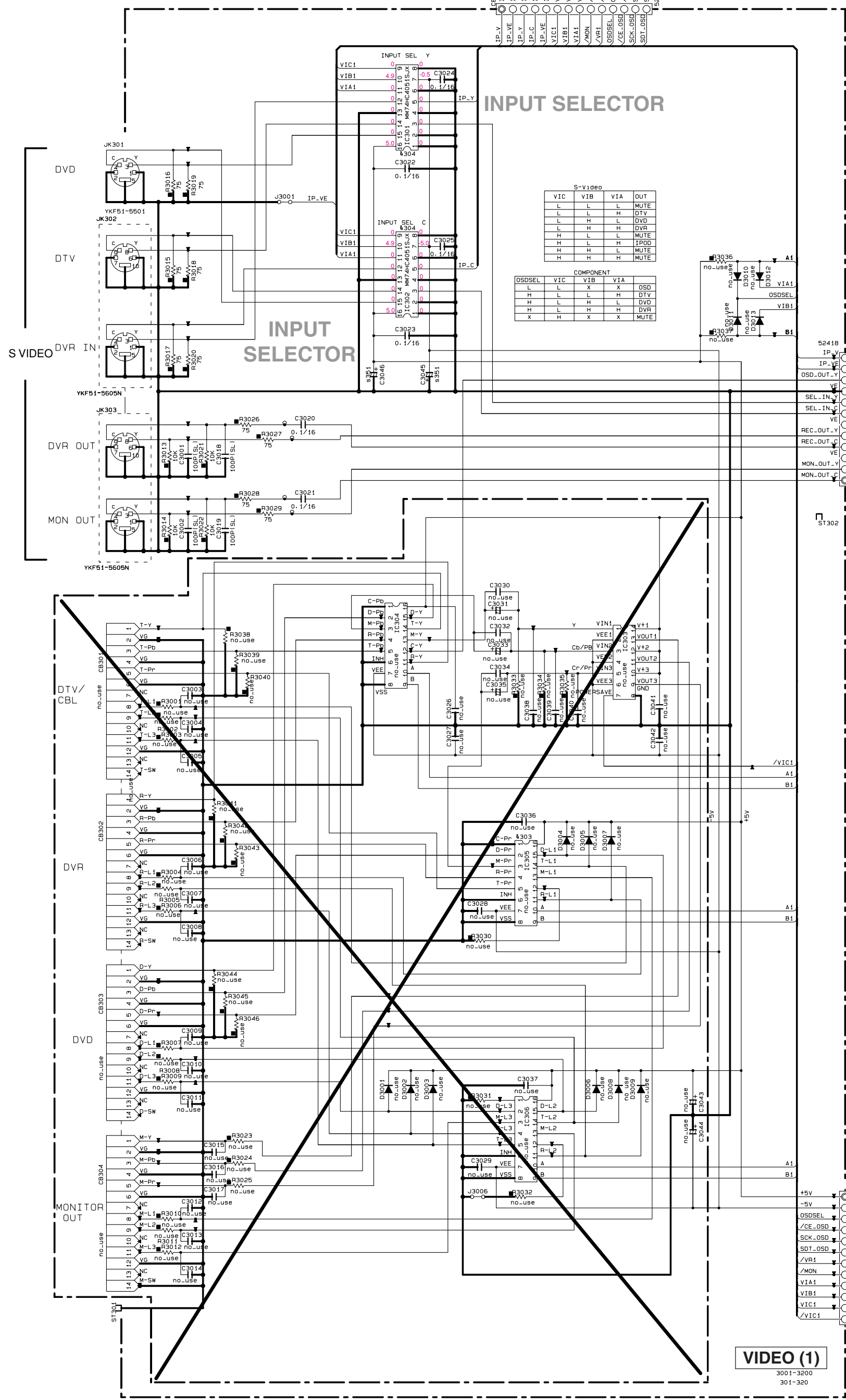

VIDEO (1) 3001-3000 301-300

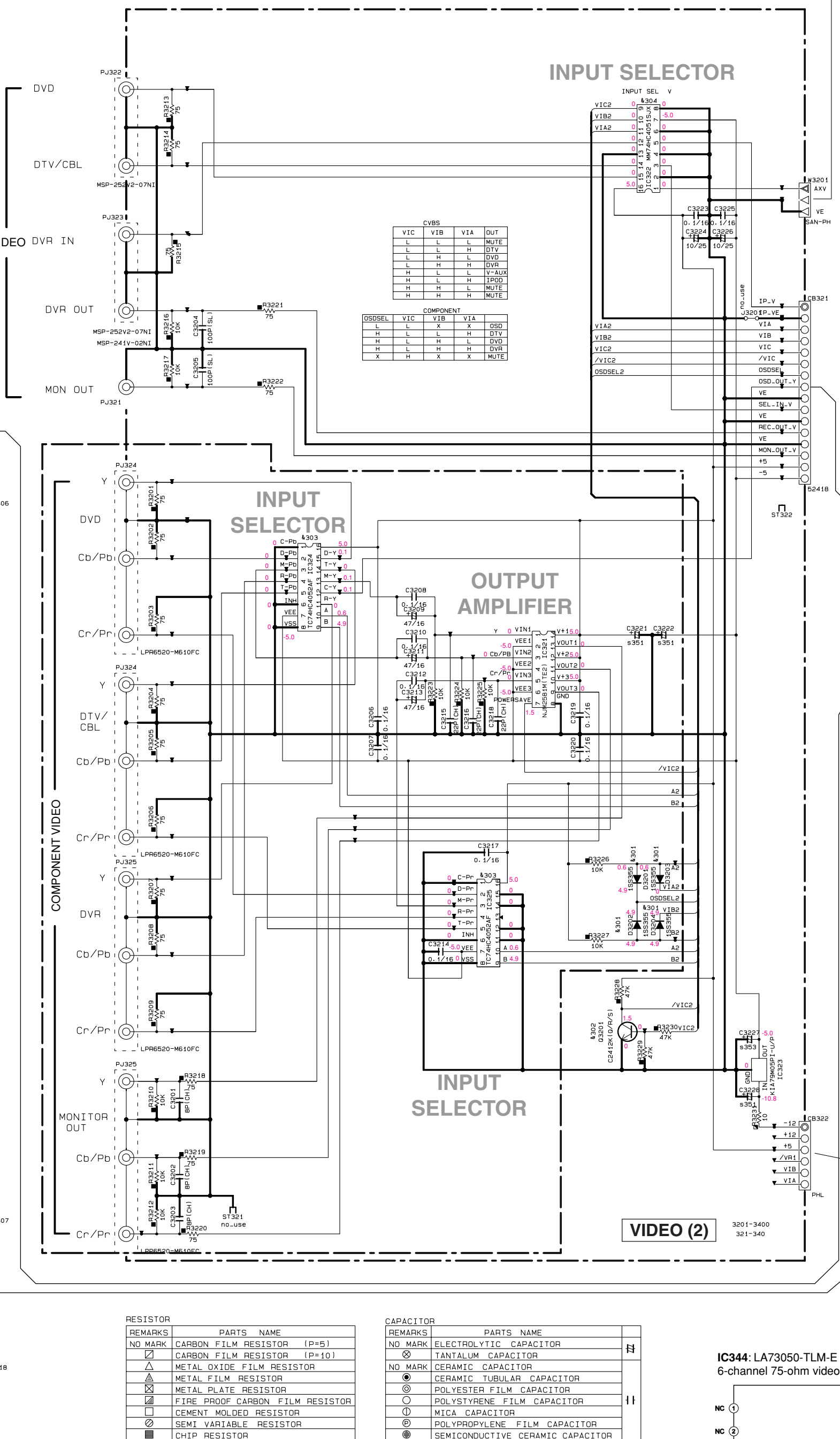

VIDEO (2) 3001-3000 301-300

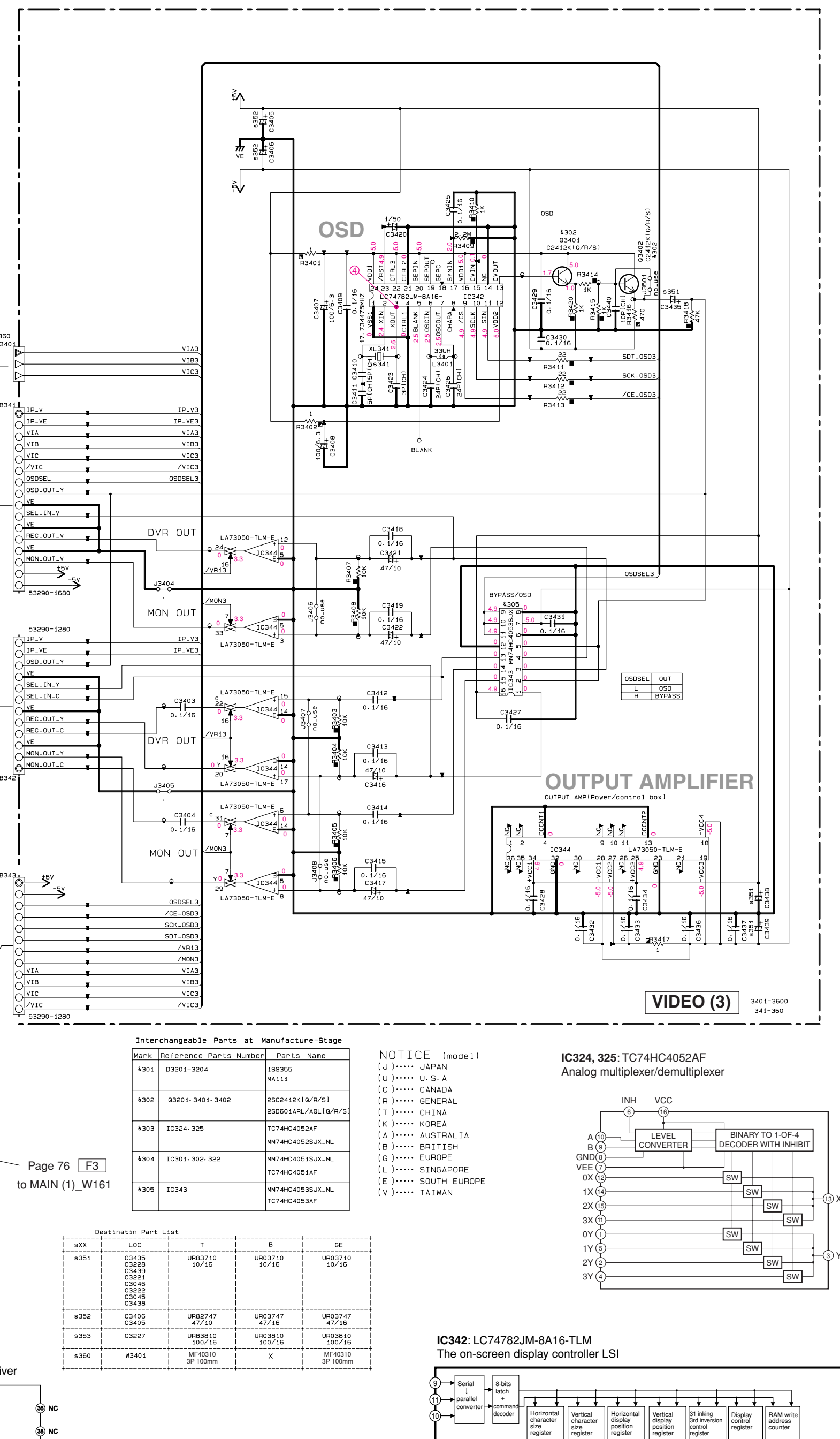

VIDEO (3) 3401-3600 341-360

REMARKS	PARTS NAME	REMARKS	PARTS NAME
NO MARK	CARBON FILM RESISTOR (P=5)	NO MARK	ELECTROLYTIC CAPACITOR
△	CARBON FILM RESISTOR (P=10)	∅	TANTALUM CAPACITOR
▲	METAL OXIDE FILM RESISTOR	⊙	CERAMIC CAPACITOR
△	METAL FILM RESISTOR	⊙	POLYESTER FILM CAPACITOR
▲	FINE PROOF CARBON FILM RESISTOR	⊙	POLYETHYLENE FILM CAPACITOR
⊙	CEMENT MOLDED RESISTOR	⊙	MICA CAPACITOR
⊙	POLYPROPYLENE FILM RESISTOR	⊙	SEMI-VARIABLE RESISTOR
⊙	CHIP RESISTOR	⊙	SEMICONDUCTIVE CERAMIC CAPACITOR

Interchangeable Parts at Manufacture-Stage

Mark	Reference Parts Number	Parts Name
[J]	0301-3004	39305 M4111
[U]	0301-3401-3402	29241K1G/W/S1 292601ARL/AGL/G/W/S1
[K]	IC324-325	TC74HC4052AF
[A]	IC301-302-322	M74HC4051JX.NL M74HC4051AF
[E]	IC343	M74HC4053JX.NL TC74HC4053AF

NOTICE (model)

[J] JAPAN
 [U] U.S.A
 [C] CANADA
 [R] GENERAL
 [T] CHINA
 [K] KOREA
 [A] AUSTRALIA
 [B] BRITISH
 [G] EUROPE
 [L] SINGAPORE
 [E] SOUTH EUROPE
 [V] TAIWAN

IC324, 325: TC74HC4052AF Analog multiplexer/demultiplexer

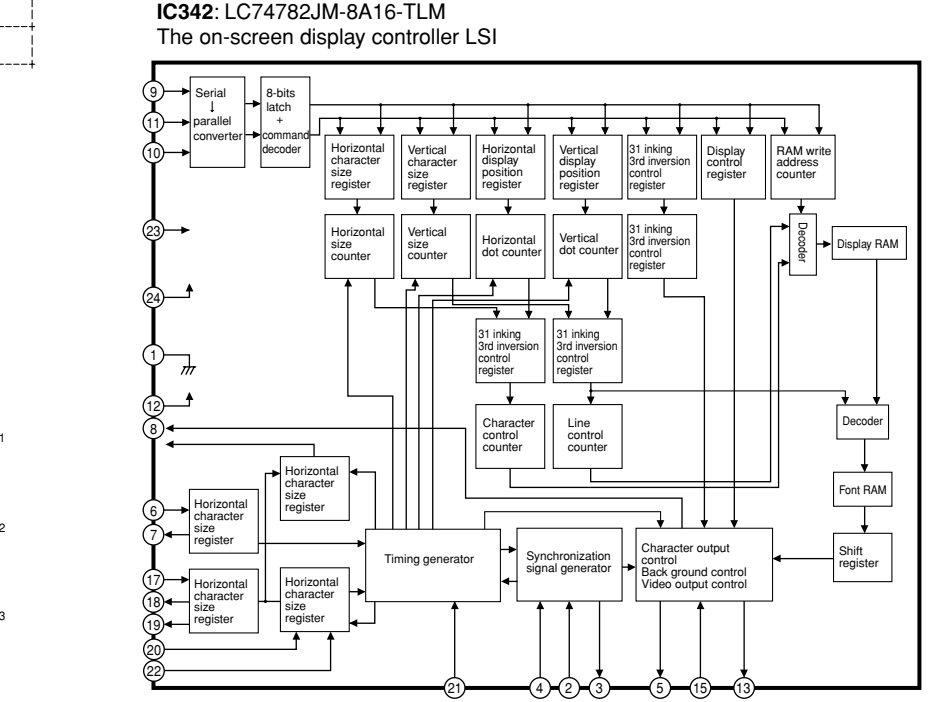
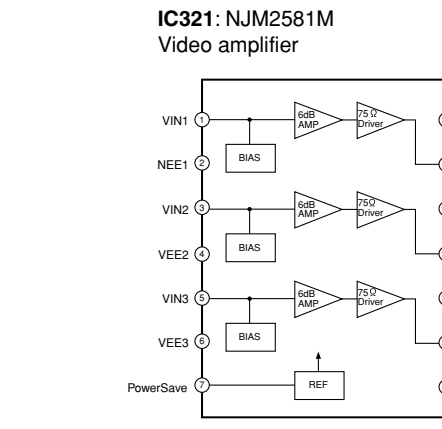
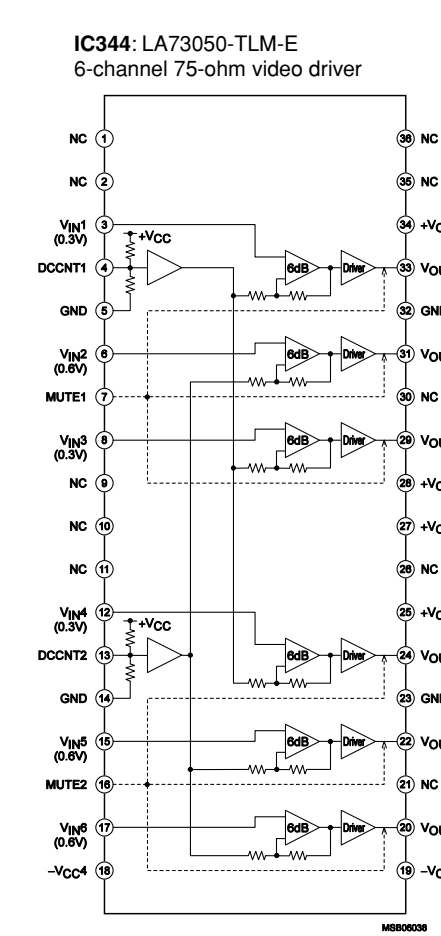
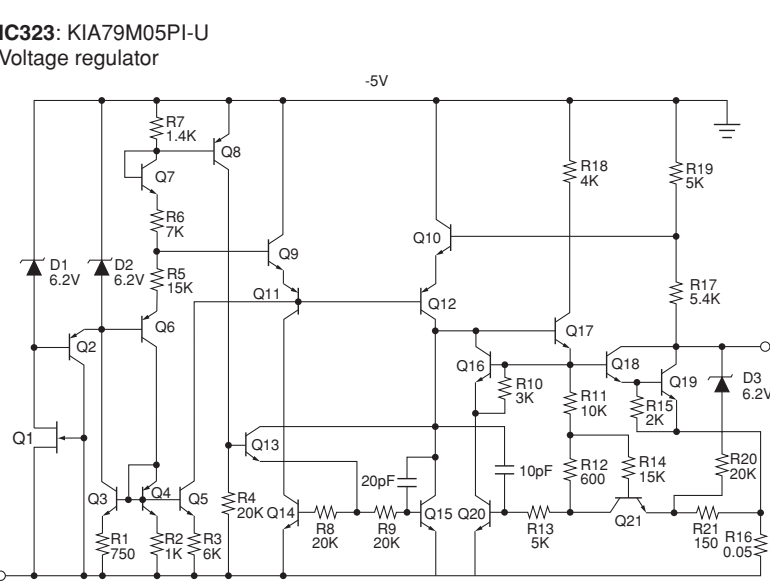
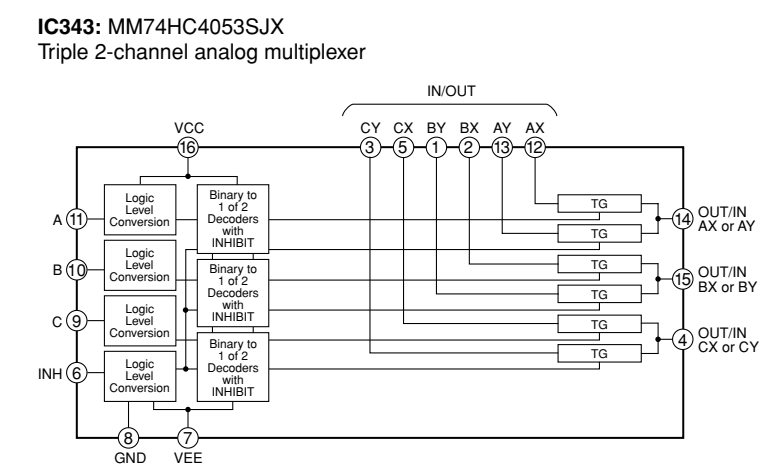
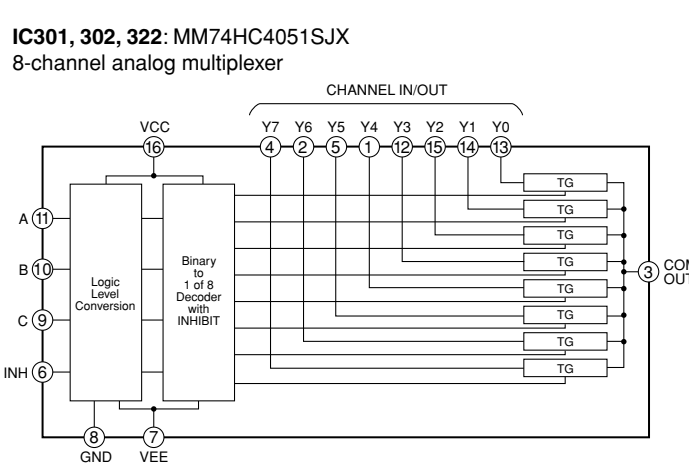
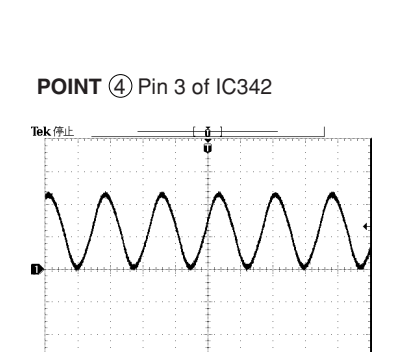
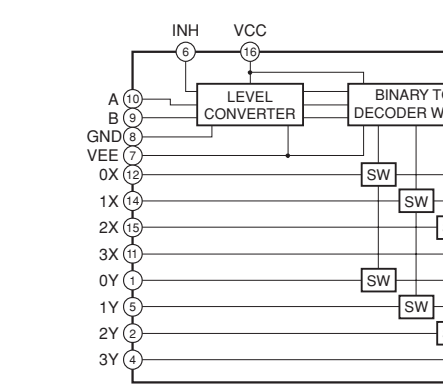

* All voltages are measured with a 10MΩ/V DC electronic voltmeter.
 * Components having special characteristics are marked 1, and must be replaced with parts having specifications equal to those originally installed.
 * Schematic diagram is subject to change without notice.

VIDEO 2/2

Destinatin Part List			
sXX	LOC	T	BGE
s383	TE381	WK56080 MST-204V1-01 NC	WK56090 MST-204V1-01 WC
s384	TE382	WK56100 MST-207V1-01 NC	WK56110 MST-207V1-01 WC

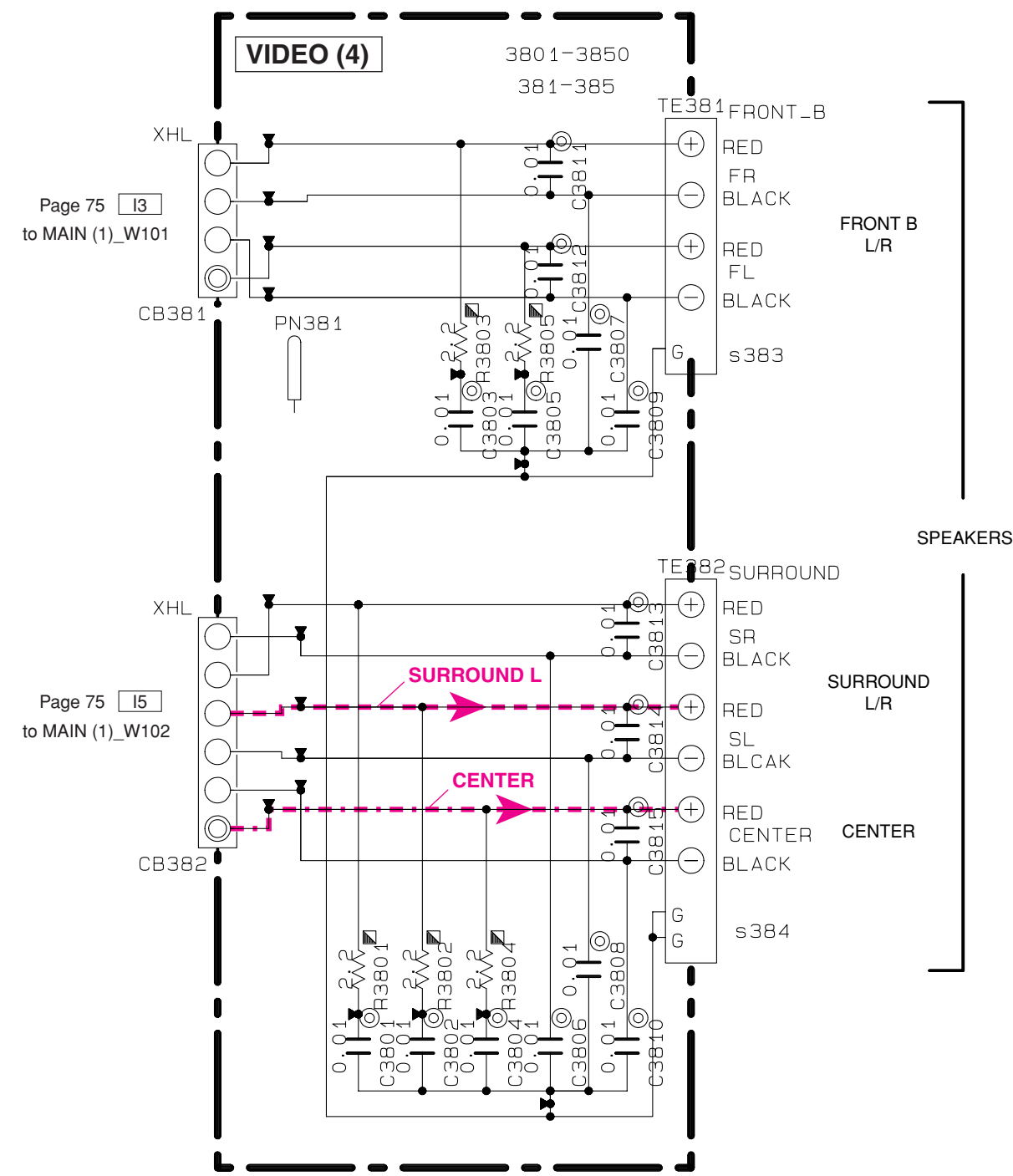

NOTICE (model)
 (J)..... JAPAN
 (U)..... U. S. A
 (C)..... CANADA
 (R)..... GENERAL
 (T)..... CHINA
 (K)..... KOREA
 (A)..... AUSTRALIA
 (B)..... BRITISH
 (G)..... EUROPE
 (L)..... SINGAPORE
 (E)..... SOUTH EUROPE
 (V)..... TAIWAN

RESISTOR

REMARKS	PARTS NAME
NO MARK	CARBON FILM RESISTOR (P=5)
☐	CARBON FILM RESISTOR (P=10)
△	METAL OXIDE FILM RESISTOR
▲	METAL FILM RESISTOR
⊠	METAL PLATE RESISTOR
⊞	FIRE PROOF CARBON FILM RESISTOR
□	CEMENT MOLDED RESISTOR
⊙	SEMI VARIABLE RESISTOR
■	CHIP RESISTOR

CAPACITOR

REMARKS	PARTS NAME
NO MARK	ELECTROLYTIC CAPACITOR
⊗	TANTALUM CAPACITOR
NO MARK	CERAMIC CAPACITOR
●	CERAMIC TUBULAR CAPACITOR
◎	POLYESTER FILM CAPACITOR
○	POLYSTYRENE FILM CAPACITOR
⊖	MICA CAPACITOR
Ⓟ	POLYPROPYLENE FILM CAPACITOR
⊙	SEMICONDUCTIVE CERAMIC CAPACITOR

★ All voltages are measured with a 10MΩ/V DC electronic voltmeter.
 ★ Components having special characteristics are marked with a triangle and must be replaced with parts having specifications equal to those originally installed.
 ★ Schematic diagram is subject to change without notice.

HDMI

(T, G, E models)

CXB1442R

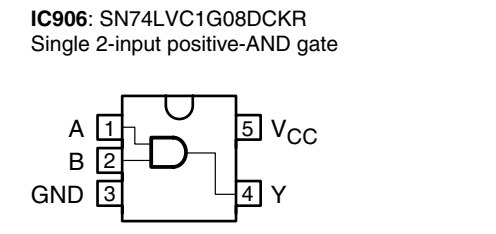
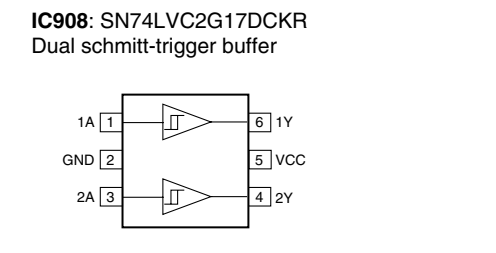
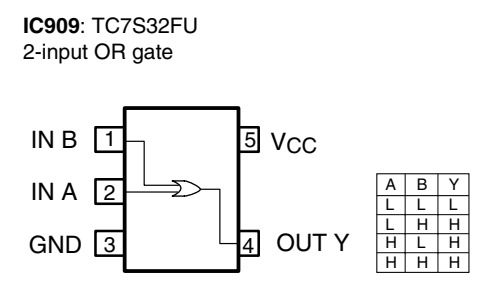
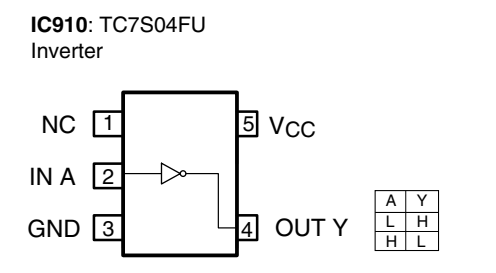
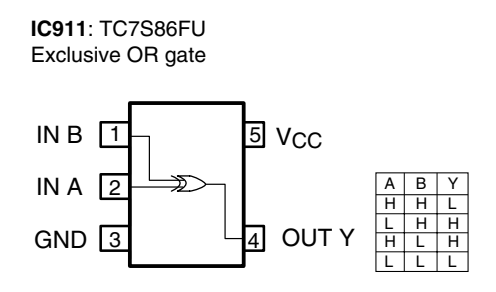
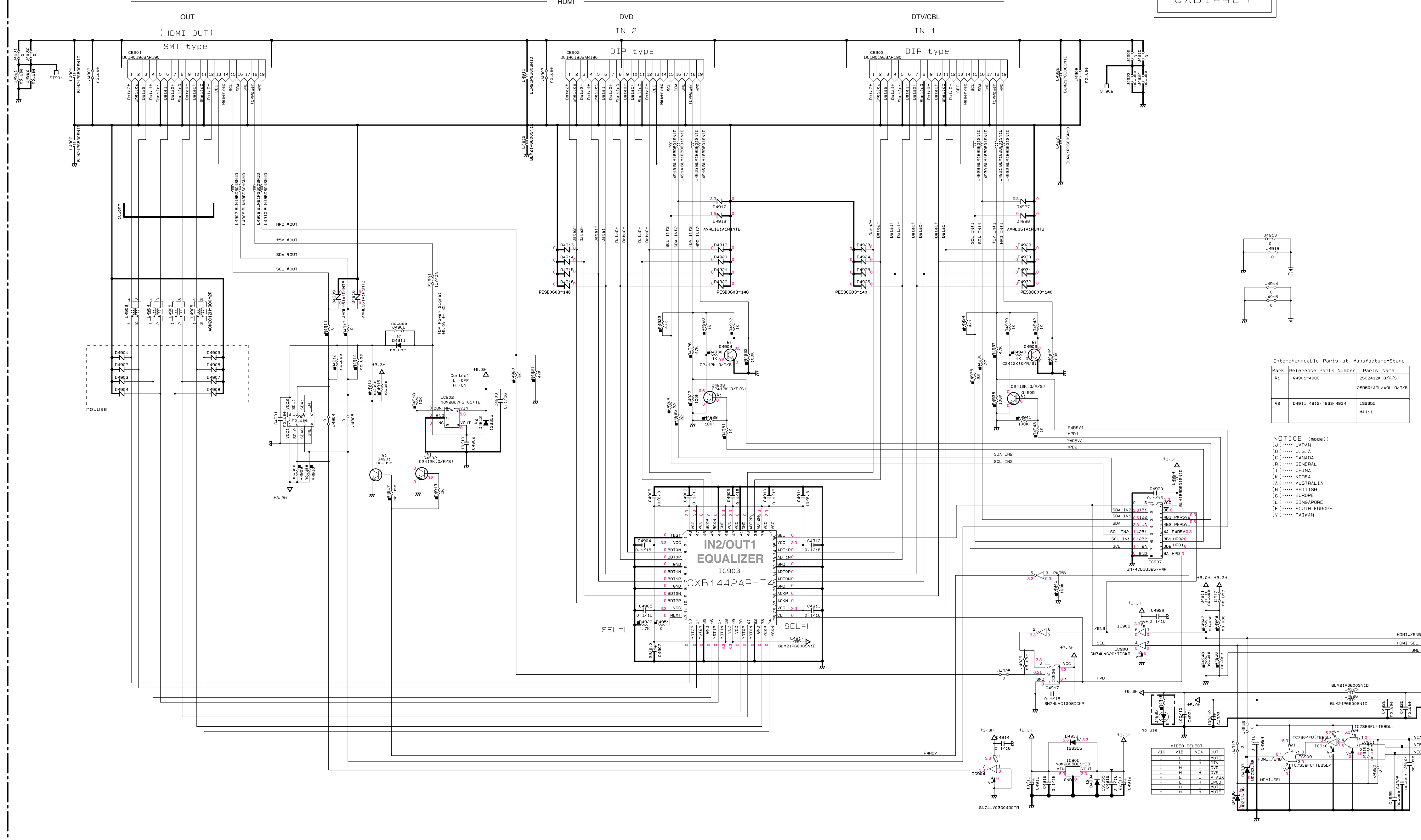

Interchangeable Parts at Manufacture-Stage

Mark	Reference	Parts Number	Parts Name
41	04901-4906	2SC2412N (Q/R/S)	
42	04911-4912-4933-4934	1S5355	2SD6014RL (Q/R/S)
		M4111	

NOTICE (note1)
 (J)..... JAPAN
 (U)..... U.S.A.
 (C)..... CANADA
 (H)..... GENERAL
 (T)..... CHINA
 (K)..... KOREA
 (A)..... AUSTRALIA
 (B)..... BRITISH
 (G)..... EUROPE
 (L)..... SINGAPORE
 (E)..... SOUTH EUROPE
 (Y)..... TAIWAN

Page 74 [A9] to OPERATION (2)_W2154 (T, G, E models)

Page 77 [I3] to VIDEO (3)_W3401 (T, G, E models)

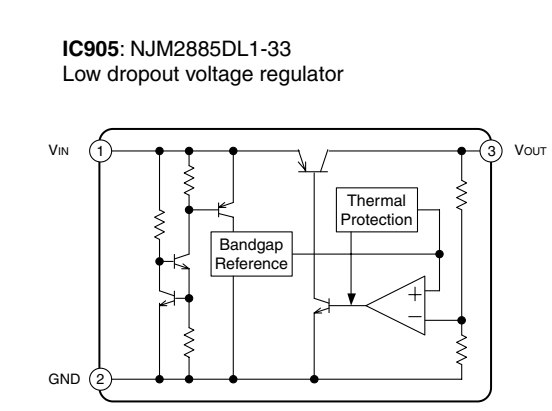
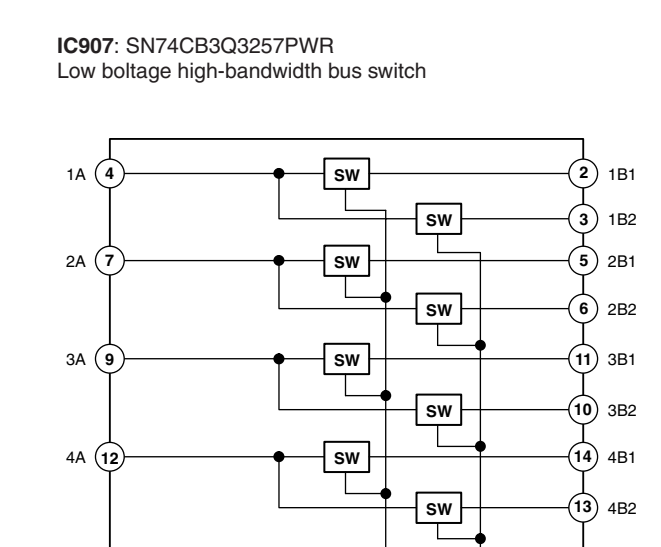
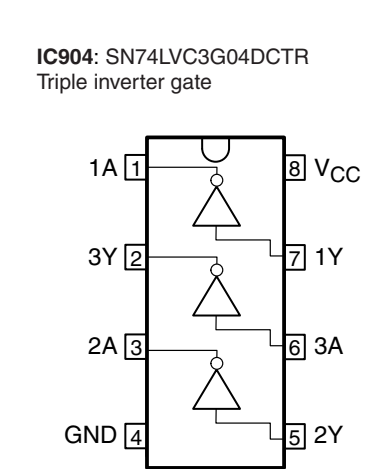
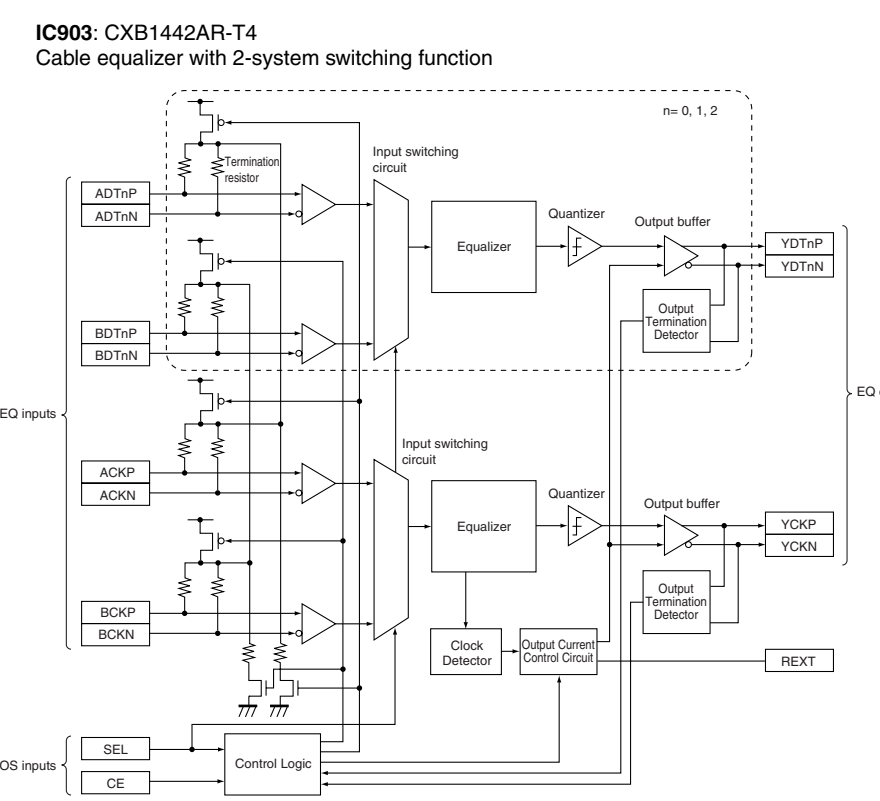
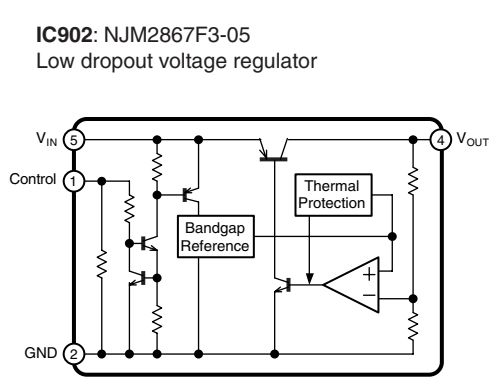

* All voltages are measured with a 10MΩ/V DC electronic voltmeter.
 * Components having special characteristics are marked with a triangle symbol and must be replaced with parts having specifications equal to those originally installed.
 * Schematic diagram is subject to change without notice.

DAB

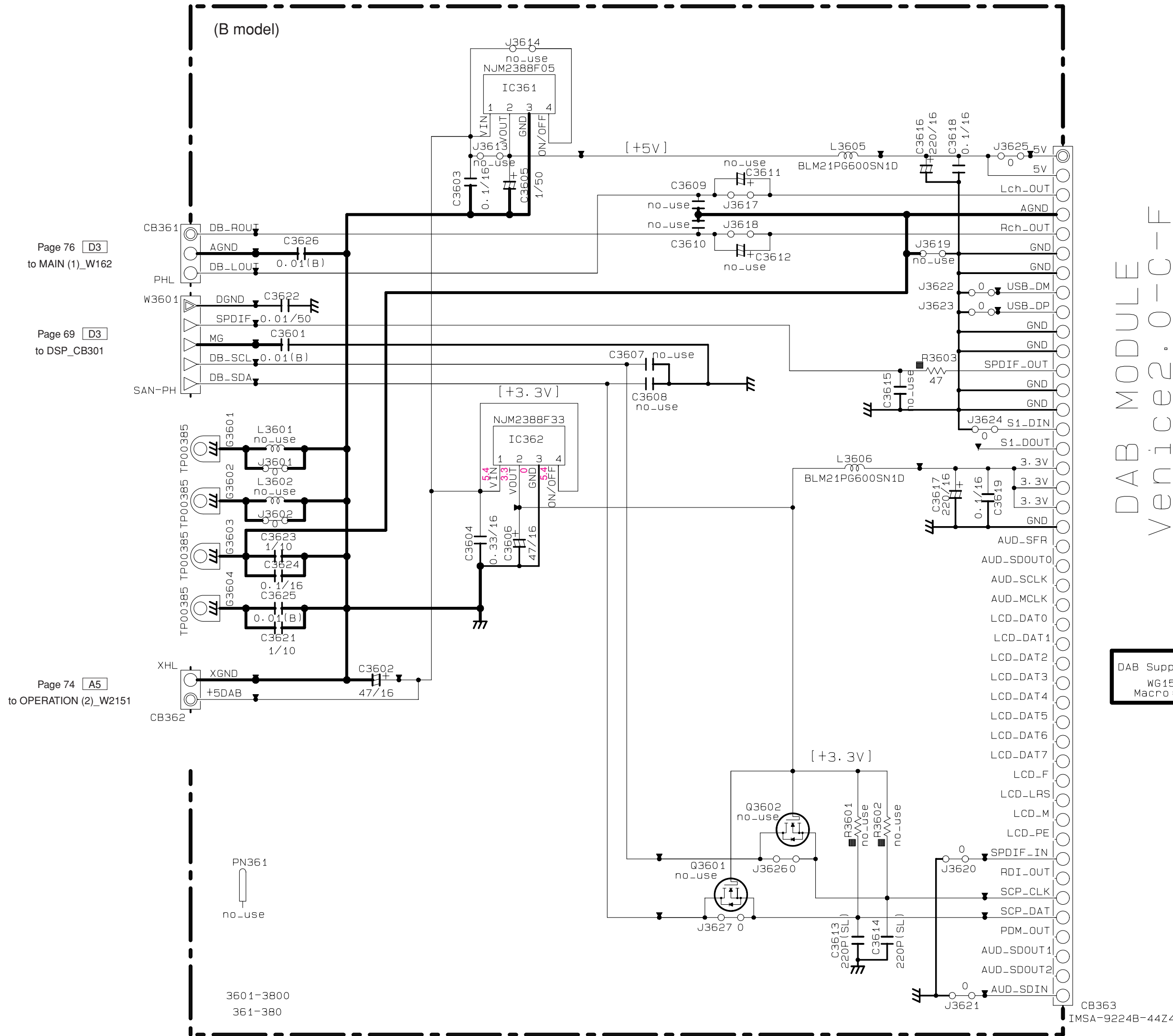

DAB MODULE Verice2.0-C-F

RESISTOR

REMARKS	PARTS NAME
NO MARK	CARBON FILM RESISTOR (P=5)
□	CARBON FILM RESISTOR (P=10)
△	METAL OXIDE FILM RESISTOR
▲	METAL FILM RESISTOR
⊠	METAL PLATE RESISTOR
▨	FIRE PROOF CARBON FILM RESISTOR
□	CEMENT MOLDED RESISTOR
⊗	SEMI VARIABLE RESISTOR
■	CHIP RESISTOR

CAPACITOR

REMARKS	PARTS NAME
NO MARK	ELECTROLYTIC CAPACITOR
⊗	TANTALUM CAPACITOR
NO MARK	CERAMIC CAPACITOR
●	CERAMIC TUBULAR CAPACITOR
⊙	POLYESTER FILM CAPACITOR
○	POLYSTYRENE FILM CAPACITOR
⊖	MICA CAPACITOR
⊕	POLYPROPYLENE FILM CAPACITOR
⊗	SEMICONDUCTIVE CERAMIC CAPACITOR

NOTICE (model)

- (J)..... JAPAN
- (U)..... U. S. A
- (C)..... CANADA
- (R)..... GENERAL
- (T)..... CHINA
- (K)..... KOREA
- (A)..... AUSTRALIA
- (B)..... BRITISH
- (G)..... EUROPE
- (L)..... SINGAPORE
- (E)..... SOUTH EUROPE
- (V)..... TAIWAN

IC361: NJM2388F05
Low dropout voltage regulator with ON/OFF control

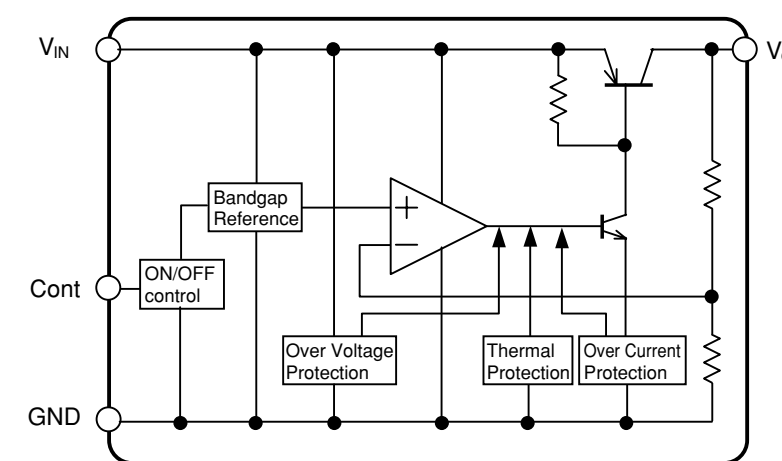

IC362: NJM2388F33
Low dropout voltage regulator with ON/OFF control

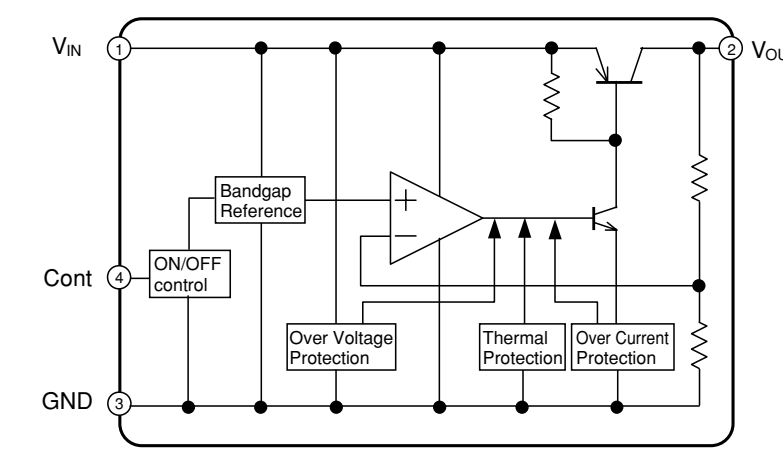

★ All voltages are measured with a 10MQ/V DC electronic voltmeter.
 ★ Components having special characteristics are marked with a triangle and must be replaced with parts having specifications equal to those originally installed.
 ★ Schematic diagram is subject to change without notice.

■ REPLACEMENT PARTS LIST

• ELECTRICAL COMPONENT PARTS

WARNING

- Components having special characteristics are marked \triangle and must be replaced with parts having specifications equal to those originally installed.
- The chip resistor is not supplied as a replacement part.
 - * When a chip resistor is necessary, use the following part.
AAX60720: CHIP RESISTOR SAMPLE BOOK

ABBREVIATIONS IN THIS LIST ARE AS FOLLOWS:

C.A.EL.CHP	: CHIP ALUMI.ELECTROLYTIC CAP	L.EMIT	: LIGHT EMITTING MODULE
C.CE	: CERAMIC CAP	LED.DSPLY	: LED DISPLAY
C.CE.ARRAY	: CERAMIC CAP ARRAY	LED.INFRD	: LED,INFRARED
C.CE.CHP	: CHIP CERAMIC CAP	MODUL.RF	: MODULATOR,RF
C.CE.ML	: MULTILAYER CERAMIC CAP	PHOT.CPL	: PHOTO COUPLER
C.CE.M.CHP	: CHIP MULTILAYER CERAMIC CAP	PHOT.INTR	: PHOTO INTERRUPTER
C.CE.SAFTY	: RECOGNIZED CERAMIC CAP	PHOT.RFLCT	: PHOTO REFLECTOR
C.CE.TUBLR	: CERAMIC TUBULAR CAP	PIN.TEST	: PIN,TEST POINT
C.CE.SMI	: SEMI CONDUCTIVE CERAMIC CAP	PLST.RIVET	: PLASTIC RIVET
C.EL	: ELECTROLYTIC CAP	R.ARRAY	: RESISTOR ARRAY
C.MICA	: MICA CAP	R.CAR.	: CARBON RESISTOR
C.ML.FLM	: MULTILAYER FILM CAP	R.CAR.CHP	: CHIP RESISTOR
C.MP	: METALLIZED PAPER CAP	R.CAR.FP	: FLAME PROOF CARBON RESISTOR
C.MYLAR	: MYLAR FILM CAP	R.FUS	: FUSABLE RESISTOR
C.MYLAR.ML	: MULTILAYER MYLAR FILM CAP	R.MTL.CHP	: CHIP METAL FILM RESISTOR
C.PAPER	: PAPER CAPACITOR	R.MTL.FLM	: METAL FILM RESISTOR
C.PLS	: POLYSTYRENE FILM CAP	R.MTL.OXD	: METAL OXIDE FILM RESISTOR
C.POL	: POLYESTER FILM CAP	R.MTL.PLAT	: METAL PLATE RESISTOR
C.POLY	: POLYETHYLENE FILM CAP	RSNR.CE	: CERAMIC RESONATOR
C.PP	: POLYPROPYLENE FILM CAP	RSNR.CRYS	: CRYSTAL RESONATOR
C.TNTL	: TANTALUM CAP	R.TW.CEM	: TWIN CEMENT FIXED RESISTOR
C.TNTL.CHP	: CHIP TANTALUM CAP	R.CEMENT	: CEMENT RESISTOR
C.TRIM	: TRIMMER CAP	SCR.BND.HD	: BIND HEAD B-TIGHT SCREW
CN	: CONNECTOR	SCR.BW.HD	: BW HEAD TAPPING SCREW
CN.BS.PIN	: CONNECTOR,BASE PIN	SCR.CUP	: CUP TIGHT SCREW
CN.CANNON	: CONNECTOR,CANNON	SCR.TERM	: SCREW TERMINAL
CN.DIN	: CONNECTOR,DIN	SCR.TR	: SCREW,TRANSISTOR
CN.FLAT	: CONNECTOR,FLAT CABLE	SUPRT.PCB	: SUPPORT,P.C.B.
CN.POST	: CONNECTOR,BASE POST	SURG.PRTCT	: SURGE PROTECTOR
COIL.MX.AM	: COIL,AM MIX	SW.TACT	: TACT SWITCH
COIL.AT.FM	: COIL,FM ANTENNA	SW.LEAF	: LEAF SWITCH
COIL.DT.FM	: COIL,FM DETECT	SW.LEVER	: LEVER SWITCH
COIL.MX.FM	: COIL,FM MIX	SW.MICRO	: MICRO SWITCH
COIL.OUTPT	: OUTPUT COIL	SW.PUSH	: PUSH SWITCH
DIOD.ARRAY	: DIODE ARRAY	SW.RT.ENC	: ROTARY ENCODER
DIODE.BRG	: DIODE BRIDGE	SW.RT.MTR	: ROTARY SWITCH WITH MOTOR
DIODE.CHP	: CHIP DIODE	SW.RT	: ROTARY SWITCH
DIODE.VAR	: VARACTOR DIODE	SW.SLIDE	: SLIDE SWITCH
DIOD.Z.CHP	: CHIP ZENER DIODE	TERM.SP	: SPEAKER TERMINAL
DIODE.ZENR	: ZENER DIODE	TERM.WRAP	: WRAPPING TERMINAL
DSCR.CE	: CERAMIC DISCRIMINATOR	THRMST.CHP	: CHIP THERMISTOR
FER.BEAD	: FERRITE BEADS	TR.CHP	: CHIP TRANSISTOR
FER.CORE	: FERRITE CORE	TR.DGT	: DIGITAL TRANSISTOR
FET.CHP	: CHIP FET	TR.DGT.CHP	: CHIP DIGITAL TRANSISTOR
FL.DSPLY	: FLUORESCENT DISPLAY	TRANS	: TRANSFORMER
FLTR.CE	: CERAMIC FILTER	TRANS.PULS	: PULSE TRANSFORMER
FLTR.COMB	: COMB FILTER MODULE	TRANS.PWR	: POWER TRANSFORMER ASS'Y
FLTR.LC.RF	: LC FILTER,EMI	TUNER.AM	: TUNER PACK,AM
GND.MTL	: GROUND PLATE	TUNER.FM	: TUNER PACK,FM
GND.TERM	: GROUND TERMINAL	TUNER.PK	: FRONT-ENDTUNER PACK
HOLDER.FUS	: FUSE HOLDER	VR	: ROTARY POTENTIOMETER
IC.PRTCT	: IC PROTECTOR	VR.MTR	: POTENTIOMETER WITH MOTOR
JUMPER.CN	: JUMPER CONNECTOR	VR.SW	: POTENTIOMETER WITH ROTARY SW
JUMPER.TST	: JUMPER,TEST POINT	VR.SLIDE	: SLIDE POTENTIOMETER
L.DTCT	: LIGHT DETECTING MODULE	VR.TRIM	: TRIMMER POTENTIOMETER

P.C.B. DSP

*
*
*

Ref. No.	Part No.	Description		Markets
	WK038500	P. C. B.	DSP	T
	WK038700	P. C. B.	DSP	B
	WK038600	P. C. B.	DSP	GE
CB301	VB390100	CN. BS. PIN	5P	B
CB408	VF982300	CN. BS. PIN	17P	
CB501	VQ961000	CN. BS. PIN	7P	
CB502	VQ961800	CN. BS. PIN	15P	
CB504	VN394900	CN. BS. PIN	14P	
CB512	VQ047500	CN. BS. PIN	20P	
CB516	VK025700	CN. BS. PIN	13P	
CB603	VB858500	CN. BS. PIN	6P	
C101	UR838220	C. EL	220uF 16V	T
C101	UR238220	C. EL	220uF 16V	BGE
C102	WH771300	C. EL	100uF 10V	
C103-104	US135100	C. CE. CHP	0. 1uF 16V	
C105	US061270	C. CE. CHP	27pF 50V B	
C106	WH771300	C. EL	100uF 10V	
C107	US135100	C. CE. CHP	0. 1uF 16V	
C108-129	US063100	C. CE. CHP	1000pF 50V B	
C130	US135100	C. CE. CHP	0. 1uF 16V	
C131	US061270	C. CE. CHP	27pF 50V B	
C132	UR837100	C. EL	10uF 16V	T
C132	URO37100	C. EL	10uF 16V	BGE
C133	US063100	C. CE. CHP	1000pF 50V B	
C135	UB446100	C. CE. CHP	1uF 16V	
C136-147	US063100	C. CE. CHP	1000pF 50V B	
C148-154	UB446100	C. CE. CHP	1uF 16V	
C201-206	US063100	C. CE. CHP	1000pF 50V B	
C207-211	US135100	C. CE. CHP	0. 1uF 16V	
C212	US063100	C. CE. CHP	1000pF 50V B	
C213	US135100	C. CE. CHP	0. 1uF 16V	
C214	US064100	C. CE. CHP	0. 01uF 50V B	
C215-218	UB446100	C. CE. CHP	1uF 16V	
C301-304	US135100	C. CE. CHP	0. 1uF 16V	
C305	UR837470	C. EL	47uF 16V	T
C305	UU238100	C. EL	100uF 16V	BGE
C306	US135100	C. CE. CHP	0. 1uF 16V	
C307	US063100	C. CE. CHP	1000pF 50V B	
C308	UR837100	C. EL	10uF 16V	T
C308	URO37100	C. EL	10uF 16V	BGE
C309-310	US061270	C. CE. CHP	27pF 50V B	
C311	UR866220	C. EL	2. 2uF 50V	
C312	US135100	C. CE. CHP	0. 1uF 16V	
C313	US061220	C. CE. CHP	22pF 50V B	
C314	UR847220	C. EL	22uF 25V	T
C314	UR247220	C. EL	22uF 25V	BGE
C315-318	US135100	C. CE. CHP	0. 1uF 16V	
C321	US135100	C. CE. CHP	0. 1uF 16V	
C342-346	US063100	C. CE. CHP	1000pF 50V B	
C349	UR837100	C. EL	10uF 16V	T
C349	URO37100	C. EL	10uF 16V	BGE
C350	UR837100	C. EL	10uF 16V	T
C350	URO37100	C. EL	10uF 16V	BGE
C351-352	US063100	C. CE. CHP	1000pF 50V B	
C354	US063100	C. CE. CHP	1000pF 50V B	
C401-402	US135100	C. CE. CHP	0. 1uF 16V	
C404	UR837470	C. EL	47uF 16V	T
C404	URO37470	C. EL	47uF 16V	BGE
C405	US135100	C. CE. CHP	0. 1uF 16V	
C406	UB446100	C. CE. CHP	1uF 16V	

* New Parts

Ref. No.	Part No.	Description			Markets
C407-408	US062100	C. CE. CHP	100pF 50V B		
C409	US135100	C. CE. CHP	0. 1uF 16V		
C410	US062100	C. CE. CHP	100pF 50V B		
C413-416	US063100	C. CE. CHP	1000pF 50V B		
C417	US062470	C. CE. CHP	470pF 50V B		
C418-423	US063100	C. CE. CHP	1000pF 50V B		
C424	US135100	C. CE. CHP	0. 1uF 16V		
C425-428	US063100	C. CE. CHP	1000pF 50V B		
C429-435	US062100	C. CE. CHP	100pF 50V B		
C501	US062100	C. CE. CHP	100pF 50V B		
C502	UR838220	C. EL	220uF 16V	T	
C502	UR238220	C. EL	220uF 16V	BGE	
C503-504	US062100	C. CE. CHP	100pF 50V B		
C513-515	US062100	C. CE. CHP	100pF 50V B		
C516	US035100	C. CE. CHP	0. 1uF 16V B		
C517-518	US062100	C. CE. CHP	100pF 50V B		
C519	US135100	C. CE. CHP	0. 1uF 16V		
C520	US035100	C. CE. CHP	0. 1uF 16V B		
C521	US063100	C. CE. CHP	1000pF 50V B		
C522-523	US135100	C. CE. CHP	0. 1uF 16V		
C524-525	US063100	C. CE. CHP	1000pF 50V B		
C527-528	US064100	C. CE. CHP	0. 01uF 50V B		
C529	US062100	C. CE. CHP	100pF 50V B		
C530	US064100	C. CE. CHP	0. 01uF 50V B		
C531-534	US062100	C. CE. CHP	100pF 50V B		
C535	US064100	C. CE. CHP	0. 01uF 50V B		
C536-549	US062100	C. CE. CHP	100pF 50V B		
C550	US064100	C. CE. CHP	0. 01uF 50V B		
C601	US135100	C. CE. CHP	0. 1uF 16V	TGE	
C602	US064100	C. CE. CHP	0. 01uF 50V B	TGE	
C603-608	US062220	C. CE. CHP	220pF 50V B	B	
C609	UA064100	C. CE. CHP	0. 01uF 50V	TGE	
C609	US135100	C. CE. CHP	0. 1uF 16V	B	
C610	US061150	C. CE. CHP	15pF 50V B	TGE	
C611	US061120	C. CE. CHP	12pF 50V B	TGE	
C612-613	US061470	C. CE. CHP	47pF 50V B	TGE	
C614-615	US135100	C. CE. CHP	0. 1uF 16V	TGE	
C616	UB446100	C. CE. CHP	1uF 16V	TGE	
C617	US135100	C. CE. CHP	0. 1uF 16V	TGE	
C618	UR838100	C. EL	100uF 16V	TGE	
C619-621	US135100	C. CE. CHP	0. 1uF 16V	TGE	
C623	US063100	C. CE. CHP	1000pF 50V B		
C624	US135100	C. CE. CHP	0. 1uF 16V	TGE	
C625	US063100	C. CE. CHP	1000pF 50V B	B	
C626	US064100	C. CE. CHP	0. 01uF 50V B	B	
C627-628	UB446100	C. CE. CHP	1uF 16V	TGE	
C630	US063100	C. CE. CHP	1000pF 50V B		
D101	VS597600	DIODE. CHP	RB160L-40 TE25		
D401	VU171400	DIODE. ZENR	UDZS3. 3BTE-17 3.3V		
D402	VU171400	DIODE. ZENR	UDZS3. 3BTE-17 3.3V	BGE	
D403-404	VU171400	DIODE. ZENR	UDZS3. 3BTE-17 3.3V		
D405	VT332900	DIODE	1SS355		
D407	VT332900	DIODE	1SS355		
D408-409	VU171400	DIODE. ZENR	UDZS3. 3BTE-17 3.3V		
D602	VT332900	DIODE	1SS355	B	
G101	WB438000	TERM. GND	M4 SD00433-21		
IC101	X7534A00	IC. CPU	ADSP-BF531 CPU		
IC102	X8653A00	IC	BR25L320F-W EEPROM		
IC201	X9060C00	IC	S29AL016D70TF1020	boot only	
IC202	X5665B00	IC	W9864G6EH-7 SDRAM		

* New Parts

RX-V461/HTR-6040/
RX-V461DAB

P.C.B. DSP and P.C.B. OPERATION

Ref. No.	Part No.	Description	Markets
IC203	X4201A00	IC SN74AHC02PWR	
IC204-207	X4285A00	IC SN74LV573APWR	
IC208	X2713A00	IC SN74AHC08PWR	
IC301	X7919A00	IC AK4588VQ	
IC302	X6123A00	IC SN74LV157APWR	
IC305	X3936A00	IC SN74LVU04APWR	
IC401	X6905A00	IC ADC084S021CIMM	
IC402-403	X5875A00	IC SN74LV4051APWR	
IC404	X2709A00	IC SN74AHCT245PWR	
IC501	X3824A00	IC SN74AHCT08PWR	
IC505	X4463A00	IC SN74LV08APWR	
* IC601	X8256A00	IC ISP1362BD USB	TGE
IC602	X4107A00	IC MIC2026-2BM	TGE
IC603	XY417A00	IC SN74CBTLV16210GR	TGE
IC604	X6068A00	IC TC7S208FU AND GATE	TGE
PJ301	V8795700	JACK. PIN 1P	
Q101	WE736300	FET RTQ040P02	
Q501	WE736300	FET RTQ040P02	
U301-302	WJ625100	CN. PHOTO. R 1P JSR1151-D	
XL101	VZ540700	RSNR. CRYST 25MHz SMD-49	
XL301	WJ625200	RSNR. CRYST 24.576MHz	
* XL601	WK878400	RSNR. CRYST 12MHz DSX530GA	TGE
	WK038800	P. C. B. OPERATION	T
	WK039100	P. C. B. OPERATION	B
	WK038900	P. C. B. OPERATION	GE
CB202	VF982300	CN. BS. PIN 17P	
CB231	VK026300	CN. BS. PIN 4P	
CB234	LB919120	CN. BS. PIN 12P	
CB235	VK024700	CN. BS. PIN 3P	
CB241	WG668100	CN. USB USB 4P SE	TGE
CB252-255	WC050700	CL. IP. FUSE EYF-52BCY	
CB256-257	VG879900	CN. BS. PIN 2P	
CB261	VB858300	CN. BS. PIN 4P	
C2001	US064100	C. CE. CHP 0.01uF 50V B	
C2002	US063100	C. CE. CHP 1000pF 50V B	
C2003	UM397100	C. EL 10uF 16V	
C2004	US062100	C. CE. CHP 100pF 50V B	
C2005	UM387470	C. EL 47uF 16V	
C2006	US135100	C. CE. CHP 0.1uF 16V	
C2007	US061330	C. CE. CHP 33pF 50V B	
C2008	UM397220	C. EL 22uF 25V	
C2009	UM397100	C. EL 10uF 16V	
C2010-2011	UM397220	C. EL 22uF 25V	
C2012	US065100	C. CE. CHP 0.1uF 50V B	
C2013-2014	US135100	C. CE. CHP 0.1uF 16V	
C2015	UR868100	C. EL 100uF 50V	T
C2015	UR068100	C. EL 100uF 50V	BGE
C2016	UM388330	C. EL 330uF 6.3V	
C2017	US135100	C. CE. CHP 0.1uF 16V	
C2018	US061680	C. CE. CHP 68pF 50V B	
C2019-2020	US062100	C. CE. CHP 100pF 50V B	
C2021	US061100	C. CE. CHP 10pF 50V B	
C2022-2024	US135100	C. CE. CHP 0.1uF 16V	
C2025	US064100	C. CE. CHP 0.01uF 50V B	
C2026	US135100	C. CE. CHP 0.1uF 16V	
C2027	UM397100	C. EL 10uF 16V	
C2028	US135100	C. CE. CHP 0.1uF 16V	

* New Parts

Ref. No.	Part No.	Description	Markets
C2029-2030	US063100	C. CE. CHP 1000pF 50V B	
C2101	US064100	C. CE. CHP 0.01uF 50V B	
C2102-2105	US044220	C. CE. CHP 0.022uF 25V B	
C2110-2111	US063100	C. CE. CHP 1000pF 50V B	
C2152	UR866100	C. EL 1uF 50V	
C2153	UR837470	C. EL 47uF 16V	
C2155	US135100	C. CE. CHP 0.1uF 16V	
C2156	US064100	C. CE. CHP 0.01uF 50V B	
C2157	US135100	C. CE. CHP 0.1uF 16V	
C2158	UR866100	C. EL 1uF 50V	
C2160	UR866100	C. EL 1uF 50V	
C2161	US135100	C. CE. CHP 0.1uF 16V	
C2162	UR866100	C. EL 1uF 50V	
C2163	UR837470	C. EL 47uF 16V	
C2164	UR837100	C. EL 10uF 16V	
C2165-2167	US135100	C. CE. CHP 0.1uF 16V	
C2168-2170	UR866100	C. EL 1uF 50V	
C2171	UR73A100	C. EL 10000uF 16V	
C2172-2173	UR866100	C. EL 1uF 50V	
C2175	UR749470	C. EL 4700uF 25V	
C2176	UR749220	C. EL 2200uF 25V	
C2177-2178	UR73A100	C. EL 10000uF 16V	
C2179-2180	VE326000	C. MYLAR 0.1uF 50V	
C2181	US135100	C. CE. CHP 0.1uF 16V	
C2182-2183	WJ605000	C. MYLAR 0.01uF 50V J	
C2184	VE326000	C. MYLAR 0.1uF 50V	
C2251	UR749220	C. EL 2200uF 25V	
C2252	WJ605000	C. MYLAR 0.01uF 50V J	
C2254	WJ605000	C. MYLAR 0.01uF 50V J	
C2257	WB121400	C. CE. SAFTY 0.01uF 295V	
C2301-2304	WJ605000	C. MYLAR 0.01uF 50V J	
C2351-2352	US135100	C. CE. CHP 0.1uF 16V	B
C2353-2354	US062220	C. CE. CHP 220pF 50V B	B
C2401-2402	US135100	C. CE. CHP 0.1uF 16V	TGE
C2403-2404	US062220	C. CE. CHP 220pF 50V B	TGE
C2405	US063100	C. CE. CHP 1000pF 50V B	TGE
C2406	US062100	C. CE. CHP 100pF 50V B	TGE
D2001	WJ249600	LED ORANGE	
D2002	VU171900	DIODE. ZENR UDZ5.1B 5.1V	
D2003	WJ249600	LED ORANGE	
D2004	VT332900	DIODE 1SS355	
D2005	WJ249600	LED ORANGE	
D2006	VT332900	DIODE 1SS355	
D2007	WJ249600	LED ORANGE	
D2008-2009	VU171500	DIODE. ZENR UDZ 3.6BTE-17 3.6V	
D2151	VT332900	DIODE 1SS355	
D2152	VS997800	DIODE 1T2	
D2154	VT332900	DIODE 1SS355	
D2156	VT332900	DIODE 1SS355	
D2157	VU171900	DIODE. ZENR UDZ5.1B 5.1V	
D2158	VS997800	DIODE 1T2	
D2160	VT332900	DIODE 1SS355	
D2162-2163	WA653100	DIODE. BRG KBP103G 1A 200V	
D2164	WJ286700	DIODE. BRG RS403M 4A 140V	
D2165	VU171900	DIODE. ZENR UDZ5.1B 5.1V	
D2166-2167	VT332900	DIODE 1SS355	
D2168	V2376600	DIODE. SHOT RB500V-40	
D2251	VD631600	DIODE 1SS133, 176	
D2253-2254	VS997800	DIODE 1T2	
D2256-2257	VS997800	DIODE 1T2	

* New Parts

RX-V461/HTR-6040/
RX-V461DAB

P.C.B. OPERATION and P.C.B. MAIN

Ref. No.	Part No.	Description	Markets
D2258-2259	WC398800	DIODE KDS160-RTK	
D2301	VU172500	DIODE.ZENR UDZS9.1B	
D2302-2303	VT332900	DIODE 1SS355	
D2351-2354	VT332900	DIODE 1SS355	B
D2401-2404	VT332900	DIODE 1SS355	TGE
△ F2251	VV071700	FUSE 3.15A 250V	
△ F2252	VT942900	FUSE T2.5A 250V	
IC201	X6386A00	IC M66003-0131FP	
IC202	X8302A00	IC AZ4580MTR-E1 OPAMP	
△ IC232	X6248A00	IC NJM2388F33	
△ IC233-234	X4928A00	IC KIA7805AP1 5V	
△ IC235	X7976A00	IC NJM2388F63 5V	
△ IC236	X4153A00	IC KIA7812AP1	
△ IC237	X4154A00	IC KIA7912P1	
△ IC238	X0515A00	IC LM61C1Z THERMAL	
JK201	WJ117300	JACK.PHONE PHONES	
JK261	V9408200	JACK.PHONE MSJ-064-05B GR	
JK266	WJ117400	JACK.MNI OPTIMIZER MIC	B
PJ241	WJ117500	CN 3P	TGE
PJ266	WJ117500	CN 3P	B
PN201-202	V9637500	PIN L=70 #18	
PN231-232	V9637500	PIN L=70 #18	
PN241	V9637500	PIN L=70 #18	TGE
PN266	V9637500	PIN L=70 #18	B
PN272-273	V9637500	PIN L=70 #18	
Q2001-2005	VV556400	TR 2SC2412K Q, R, S	
Q2011-2012	WC434800	TR.DGT KRA102S-RTK/P	
Q2013	WC435000	TR.DGT KRC102S-RTK	
Q2014	VV556400	TR 2SC2412K Q, R, S	
Q2015-2016	VV556500	TR 2SA1037K Q, R, S	
Q2017	VV556400	TR 2SC2412K Q, R, S	
Q2151	WC435100	TR.DGT KRC104S-RTK	
Q2152	VV556400	TR 2SC2412K Q, R, S	
Q2153	WC435100	TR.DGT KRC104S-RTK	
△ Q2251	VE198800	TR 2SC2705 O, Y	
△ R2163	HV753100	R. CAR. FP 1Ω 1/4W	
R2167	HV753100	R. CAR. FP 1Ω 1/4W	
△ R2169-2170	HV753100	R. CAR. FP 1Ω 1/4W	
△ R2171	WH820300	R. FUSE 1Ω 1W J	
△ R2174	WH819500	R. FUSE 0.47Ω 1W	
R2301-2302	WJ685600	R. MTL. FLM 470Ω 1W J	
△ RY251	V9366900	RELAY DLS9D1-0(M)0.25W	TGE
ST241	WA789700	SCR. TERM M3	
ST251	WA789600	SCR. TERM M3	
ST261	WA789700	SCR. TERM M3	
SW201-220	WD483100	SW. TACT SKRGAAD010	
SW221	V9597100	SW. RT. ENC EC12E2460802	
SW274	WD483100	SW. TACT SKRGAAD010	
* △ T251	X8523A00	TRANS. PWR	
△ TE251	V5867400	OUTLET. AC 2P	T
△ TE251	VU543300	OUTLET. AC 1P	B
△ TE251	VU543400	OUTLET. AC 2P	GE
U2002	WJ645300	L. DTCT SM3385UMH6	
V2001	WJ264400	FL. DSPLY 17-BT-29GNK	
	WA790900	SPACER 4.6/10/32	

* New Parts

Ref. No.	Part No.	Description	Markets
	WK038000	P. C. B. MAIN	T
	WK038200	P. C. B. MAIN	B
	WK038100	P. C. B. MAIN	GE
CB101	VQ962800	CN. BS. PIN 7P	
CB103	VK025100	CN. BS. PIN 7P	
CB104	LB932060	CN. BS. PIN 6P	
CB161	VQ047500	CN. BS. PIN 20P	
CB163	VM923600	CN. BS. PIN 13P	
CB164	VQ963600	CN. BS. PIN 15P	
CB191	VB858300	CN. BS. PIN 4P	
CB192	VB858400	CN. BS. PIN 5P	
CB193	VB858200	CN. BS. PIN 3P	
C1001	WJ605000	C. MYLAR 0.01uF 50V J	
C1002	UR837100	C. EL 10uF 16V	T
C1002	UR067100	C. EL 10uF 50V	BGE
C1003	UR837100	C. EL 10uF 16V	T
C1003	UR067100	C. EL 10uF 50V	BGE
C1004	UR866220	C. EL 2.2uF 50V	
C1005	UR837100	C. EL 10uF 16V	T
C1005	UR067100	C. EL 10uF 50V	BGE
C1006-1007	UR866220	C. EL 2.2uF 50V	
C1008-1009	UR837100	C. EL 10uF 16V	
C1010	UR877220	C. EL 22uF 63V	
C1011	WJ603300	C. MYLAR 470pF 50V J	
C1012	UR897100	C. EL 10uF 100V	T
C1012	UR297100	C. EL 10uF 100V	BGE
C1013	WJ603300	C. MYLAR 470pF 50V J	
C1014	UR897100	C. EL 10uF 100V	T
C1014	UR297100	C. EL 10uF 100V	BGE
C1015	UR877220	C. EL 22uF 63V	
C1016	UR897100	C. EL 10uF 100V	T
C1016	UR297100	C. EL 10uF 100V	BGE
C1017	UR897100	C. EL 10uF 100V	T
C1017	UR297100	C. EL 10uF 100V	BGE
C1018-1020	WJ603300	C. MYLAR 470pF 50V J	
C1021	WJ602900	C. MYLAR 100pF 50V K	
C1022	UR867330	C. EL 33uF 50V	T
C1022	UR067330	C. EL 33uF 50V	BGE
C1023	WJ602900	C. MYLAR 100pF 50V K	
C1024	UR867330	C. EL 33uF 50V	
C1025	UR867330	C. EL 33uF 50V	T
C1025	UR067330	C. EL 33uF 50V	BGE
C1026	WJ602900	C. MYLAR 100pF 50V K	
C1027	UR867330	C. EL 33uF 50V	T
C1027	UR067330	C. EL 33uF 50V	BGE
C1028	UR867330	C. EL 33uF 50V	
C1029	WJ602900	C. MYLAR 100pF 50V K	
C1030	UR897100	C. EL 10uF 100V	T
C1030	UR297100	C. EL 10uF 100V	BGE
C1031	WJ602900	C. MYLAR 100pF 50V K	
C1032	FG651100	C. CE 10pF 50V	
C1033	UR866100	C. EL 1uF 50V	
C1034-1037	FG650500	C. CE 5pF 50V	
C1038-1042	WJ605800	C. MYLAR 0.047uF 50V J	
C1043	UR866470	C. EL 4.7uF 50V	
C1044	UR828220	C. EL 220uF 10V	
C1045	UR858100	C. EL 100uF 35V	T
C1045	UR058100	C. EL 100uF 35V	BGE
C1046-1047	WJ605400	C. MYLAR 0.022uF 50V J	
C1048	UR866470	C. EL 4.7uF 50V	T

* New Parts

RX-V461/HTR-6040/
RX-V461DAB

P.C.B. MAIN

Ref. No.	Part No.	Description	Markets
C1048	UR066470	C. EL 4.7uF 50V	BGE
C1049	UR858100	C. EL 100uF 35V	T
C1049	UR058100	C. EL 100uF 35V	BGE
* ⚠ C1050-1051	WM457800	C. EL 6800uF 63V	
C1052-1055	WJ605000	C. MYLAR 0.01uF 50V J	
C1056-1057	WJ611400	C. MYLAR 0.1uF 100V J	
C1058	UR868100	C. EL 100uF 50V	T
C1058	UR068100	C. EL 100uF 50V	BGE
C1059	US064100	C. CE. CHP 0.01uF 50V B	
C1060	UR837330	C. EL 33uF 16V	
C1601	WJ605000	C. MYLAR 0.01uF 50V J	
C1602	WJ603300	C. MYLAR 470pF 50V J	
C1603	US064100	C. CE. CHP 0.01uF 50V B	
C1606-1617	US062220	C. CE. CHP 220pF 50V B	
C1618-1619	US061470	C. CE. CHP 47pF 50V B	
C1620-1623	US062220	C. CE. CHP 220pF 50V B	
C1624-1625	US061470	C. CE. CHP 47pF 50V B	
C1626-1629	UR837100	C. EL 10uF 16V	
C1631	UR866220	C. EL 2.2uF 50V	
C1632	US135100	C. CE. CHP 0.1uF 16V	
C1633	UR837100	C. EL 10uF 16V	T
C1633	UR037100	C. EL 10uF 16V	BGE
C1634	UR837100	C. EL 10uF 16V	T
C1634	UR037100	C. EL 10uF 16V	BGE
C1635	UR847470	C. EL 47uF 25V	T
C1635	UR037470	C. EL 47uF 16V	BGE
C1636	UR847470	C. EL 47uF 25V	T
C1636	UR037470	C. EL 47uF 16V	BGE
C1636	UR847470	C. EL 47uF 25V	T
C1637	UR038100	C. EL 100uF 16V	BGE
C1638	UR838100	C. EL 100uF 16V	T
C1638	UR038100	C. EL 100uF 16V	BGE
C1639-1641	US062100	C. CE. CHP 100pF 50V B	
C1642	US064100	C. CE. CHP 0.01uF 50V B	
C1643	US063100	C. CE. CHP 1000pF 50V B	
C1644	US062100	C. CE. CHP 100pF 50V B	
C1645	WJ605400	C. MYLAR 0.022uF 50V J	
C1646	WJ605800	C. MYLAR 0.047uF 50V J	
C1647	VE326200	C. MYLAR 0.15uF 50V	
C1648	UR837470	C. EL 47uF 16V	T
C1648	UR037470	C. EL 47uF 16V	BGE
C1649	WJ605400	C. MYLAR 0.022uF 50V J	
C1650-1655	UR837100	C. EL 10uF 16V	
C1656	UR837470	C. EL 47uF 16V	T
C1656	UR037470	C. EL 47uF 16V	BGE
C1657	VE326200	C. MYLAR 0.15uF 50V	
C1658	US135100	C. CE. CHP 0.1uF 16V	
C1659	WJ605800	C. MYLAR 0.047uF 50V J	
C1660	UR837470	C. EL 47uF 16V	T
C1660	UR037470	C. EL 47uF 16V	BGE
C1661	US135100	C. CE. CHP 0.1uF 16V	BGE
C1662	UR837100	C. EL 10uF 16V	T
C1662	UR067100	C. EL 10uF 50V	BGE
C1663	UR837100	C. EL 10uF 16V	T
C1663	UR067100	C. EL 10uF 50V	BGE
C1664-1665	UR837100	C. EL 10uF 16V	
C1666	UR837100	C. EL 10uF 16V	T
C1666	UR067100	C. EL 10uF 50V	BGE
C1667	UR837100	C. EL 10uF 16V	
C1668	UR838100	C. EL 100uF 16V	T

* New Parts

Ref. No.	Part No.	Description	Markets
C1668	UR038100	C. EL 100uF 16V	BGE
C1669	US062330	C. CE. CHP 330pF 50V B	BGE
C1670	UR866220	C. EL 2.2uF 50V	
C1671-1674	US162820	C. CE 820pF 50V J	
C1675	WJ603600	C. MYLAR 820pF 50V J	
C1676	WJ605800	C. MYLAR 0.047uF 50V J	
C1677-1678	UR837100	C. EL 10uF 16V	
C1679	US062330	C. CE. CHP 330pF 50V B	BGE
C1680-1682	UR837100	C. EL 10uF 16V	
C1683-1684	UR037470	C. EL 47uF 16V	BGE
C1685-1690	US062100	C. CE. CHP 100pF 50V B	
C1691	US062560	C. CE. CHP 560pF 50V B	BGE
C1692	WJ604400	C. MYLAR 3900pF 50V J	
C1693-1699	UR837100	C. EL 10uF 16V	
C1700	US061270	C. CE. CHP 27pF 50V B	BGE
C1701	US135100	C. CE. CHP 0.1uF 16V	BGE
C1702	UR838100	C. EL 100uF 16V	T
C1702	UR038100	C. EL 100uF 16V	BGE
C1703	US061270	C. CE. CHP 27pF 50V B	BGE
C1704	UR037470	C. EL 47uF 16V	BGE
C1705	UR838100	C. EL 100uF 16V	T
C1705	UR038100	C. EL 100uF 16V	BGE
C1706	UR838100	C. EL 100uF 16V	T
C1706	UR038100	C. EL 100uF 16V	BGE
C1707	US135100	C. CE. CHP 0.1uF 16V	BGE
D101-102	VD631600	DIODE 1SS133, 176	
D103	VU171900	DIODE. ZENR UDZ5.1B 5.1V	
D104	WC398800	DIODE KDS160-RTK	
D105-106	VN008700	DIODE 1SS270A	
D107	WC398800	DIODE KDS160-RTK	
D108-110	VN008700	DIODE 1SS270A	
D111-113	VD631600	DIODE 1SS133, 176	
D114-115	VN008700	DIODE 1SS270A	
⚠ D116	VG443700	DIODE. ZENR MTZJ33B 33V	
D117	VN008700	DIODE 1SS270A	
D118-119	VD631600	DIODE 1SS133, 176	
⚠ D120	WA653200	DIODE. BRG TS6P036 6A 200V	
D121	VD631600	DIODE 1SS133, 176	
D122-123	YS997800	DIODE 1T2	
D161-162	VU994300	DIODE. ZENR MA8075-H 7.7V	
D163	VU995500	DIODE. ZENR MA8100-H 10.3V	
⚠ IC101	X8190A00	IC STK433-330-E	
⚠ IC102	X7427A00	IC STK433-130-E	
IC161	X8155A00	IC R2A15215FP	
IC162-164	X8302A00	IC AZ4580MTR-E1 OPAMP	
* IC168	X8235A00	IC LC72725KM	BGE
IC169	X8302A00	IC AZ4580MTR-E1 OPAMP	
PJ161	WJ648900	JACK. PIN 6P	
PJ162	WJ649000	JACK. PIN 6P	
PJ163	WJ649300	JACK. PIN 1P	
PJ164-165	WJ649200	JACK. PIN 4P	
PN191-192	Y9637500	PIN L=70 #18	
Q101-105	VD303700	TR 2SC3326 A, B	
Q106-108	WC434800	TR. DGT KRA102S-RTK/P	
Q109	WC398400	TR 2N5551C-AT	
⚠ Q110-111	YC614000	TR 2SB1274 O, R, S	
⚠ Q112	WC398400	TR 2N5551C-AT	
⚠ Q113-114	WC397700	TR 2N5401C-AT	
⚠ Q115-119	WC398400	TR 2N5551C-AT	
⚠ Q120	WC397700	TR 2N5401C-AT	

* New Parts

RX-V461/HTR-6040/
RX-V461DAB

P.C.B. MAIN and P.C.B. VIDEO

Ref. No.	Part No.	Description	Markets
Q121-123	WC434900	TR. DGT KRA104S-RTK	
Q124	VP872600	TR 2SA1708 S, T	
Q125-126	WC434900	TR. DGT KRA104S-RTK	
Q127	WC435000	TR. DGT KRC102S-RTK	
Q128	iC181510	TR 2SC1815 Y	
Q129-132	WC435000	TR. DGT KRC102S-RTK	
Q133	WC434900	TR. DGT KRA104S-RTK	
Q161-162	VZ725900	TR 2SD1938F S, T	
Q163	WC434800	TR. DGT KRA102S-RTK/P	
Q164	iC181510	TR 2SC1815 Y	
Q165	iA101510	TR 2SA1015 Y	
Q166	iC181510	TR 2SC1815 Y	
Q167	iC174020	TR 2SC1740S QRS	BGE
R1027-1028	HV753220	R. CAR. FP 2.2Ω 1/4W	
R1031	HV755560	R. CAR. FP 560Ω 1/4W	
R1038	HV754100	R. CAR. FP 10Ω 1/4W	
R1043	HV754100	R. CAR. FP 10Ω 1/4W	
R1054	WB279900	R. CEMENT RGC55C 0.22+0.22	
R1057	WB279900	R. CEMENT RGC55C 0.22+0.22	
R1061	WB279900	R. CEMENT RGC55C 0.22+0.22	
R1069-1070	WB279900	R. CEMENT RGC55C 0.22+0.22	
R1085	HV754100	R. CAR. FP 10Ω 1/4W	
R1087	HV754100	R. CAR. FP 10Ω 1/4W	
R1089	HV754100	R. CAR. FP 10Ω 1/4W	
R1092-1093	HV754100	R. CAR. FP 10Ω 1/4W	
R1095	WB625100	R. MTL. FLM 4.7Ω 1W J	
R1099-1100	WB625100	R. MTL. FLM 4.7Ω 1W J	
R1103-1104	WB625100	R. MTL. FLM 4.7Ω 1W J	
R1106	HV756150	R. CAR. FP 1.5KΩ 1/4W	
R1107	HV753470	R. CAR. FP 4.7Ω 1/4W	
R1110	WB627300	R. MTL. OXD 470Ω 1W	
R1111	HV753470	R. CAR. FP 4.7Ω 1/4W	
R1659-1660	HV753220	R. CAR. FP 2.2Ω 1/4W	
RY101-105	WJ122400	RELAY 981-2A-24DS-SP7	
RY106	WE648700	RELAY DC DH24D2-0-0	
ST101	WA789600	SCR. TERM M3	
TE101	WK560800	TERM. SP 4P MST-204V1-01 NC	T
TE101	WK560900	TERM. SP 4P MST-204V1-01 WC	BGE
XL161	WJ588000	RSNR. CRYST 4.332MHz	BGE
	WE774200	SCR. BND. HD 3x10 MFZN2W3	
	WK038300	P. C. B. VIDEO	T
	WJ641700	P. C. B. VIDEO	B
	WK038400	P. C. B. VIDEO	GE
CB305	VF982200	CN. BS. PIN 14P	
CB306-307	VQ961500	CN. BS. PIN 12P	
CB321	VQ961900	CN 16P	
CB322	VB858500	CN. BS. PIN 6P	
CB341	VQ963700	CN. BS. PIN 16P	
CB342-343	VQ963300	CN. BS. PIN 12P	
CB381	LB919040	CN. BS. PIN 4P	
CB382	LB919060	CN. BS. PIN 6P	
C3001-3002	US062100	C. CE. CHP 100pF 50V B	
C3018-3019	US062100	C. CE. CHP 100pF 50V B	
C3020-3025	US135100	C. CE. CHP 0.1uF 16V	
C3045	UR837100	C. EL 10uF 16V	T
C3045	UR037100	C. EL 10uF 16V	BGE
C3046	UR837100	C. EL 10uF 16V	T

* New Parts

Ref. No.	Part No.	Description	Markets
C3046	UR037100	C. EL 10uF 16V	BGE
C3201-3203	US060800	C. CE. CHP 8pF 50V B	
C3204-3205	US062100	C. CE. CHP 100pF 50V B	
C3206-3208	US135100	C. CE. CHP 0.1uF 16V	
C3209	UR837470	C. EL 47uF 16V	
C3210	US135100	C. CE. CHP 0.1uF 16V	
C3211	UR837470	C. EL 47uF 16V	
C3212	US135100	C. CE. CHP 0.1uF 16V	
C3213	UR837470	C. EL 47uF 16V	
C3214	US135100	C. CE. CHP 0.1uF 16V	
C3215-3216	US061220	C. CE. CHP 22pF 50V B	
C3217	US135100	C. CE. CHP 0.1uF 16V	
C3218	US061220	C. CE. CHP 22pF 50V B	
C3219-3220	US135100	C. CE. CHP 0.1uF 16V	
C3221	UR837100	C. EL 10uF 16V	T
C3221	UR037100	C. EL 10uF 16V	BGE
C3222	UR837100	C. EL 10uF 16V	T
C3222	UR037100	C. EL 10uF 16V	BGE
C3223	US135100	C. CE. CHP 0.1uF 16V	
C3224	UR847100	C. EL 10uF 25V	
C3225	US135100	C. CE. CHP 0.1uF 16V	
C3226	UR847100	C. EL 10uF 25V	
C3227	UR838100	C. EL 100uF 16V	T
C3227	UR038100	C. EL 100uF 16V	BGE
C3228	UR837100	C. EL 10uF 16V	T
C3228	UR037100	C. EL 10uF 16V	BGE
C3403-3404	US135100	C. CE. CHP 0.1uF 16V	
C3405	UR827470	C. EL 47uF 10V	T
C3405	UR037470	C. EL 47uF 16V	BGE
C3406	UR827470	C. EL 47uF 10V	T
C3406	UR037470	C. EL 47uF 16V	BGE
C3407-3408	UR818100	C. EL 100uF 6.3V	
C3409	US135100	C. CE. CHP 0.1uF 16V	
C3410-3411	US060500	C. CE. CHP 5pF 50V B	
C3412-3415	US135100	C. CE. CHP 0.1uF 16V	
C3416-3417	UR827470	C. EL 47uF 10V	
C3418-3419	US135100	C. CE. CHP 0.1uF 16V	
C3420	UR866100	C. EL 1uF 50V	
C3421-3422	UR827470	C. EL 47uF 10V	
C3423	US060300	C. CE. CHP 3pF 50V B	
C3424	US061240	C. CE. CHP 24pF 50V B	
C3425	US135100	C. CE. CHP 0.1uF 16V	
C3426	US061240	C. CE. CHP 24pF 50V B	
C3427-3434	US135100	C. CE. CHP 0.1uF 16V	
C3435	UR837100	C. EL 10uF 16V	T
C3435	UR037100	C. EL 10uF 16V	BGE
C3436-3437	US135100	C. CE. CHP 0.1uF 16V	
C3438	UR837100	C. EL 10uF 16V	T
C3438	UR037100	C. EL 10uF 16V	BGE
C3439	UR837100	C. EL 10uF 16V	T
C3439	UR037100	C. EL 10uF 16V	BGE
C3440	US061100	C. CE. CHP 10pF 50V B	
C3801-3815	WJ605000	C. MYLAR 0.01uF 50V J	
D3201-3204	VT332900	DIODE 1SS355	
IC301-302	XY550A00	IC MM74HC4051SJX	
IC321	X2904A00	IC NJM2581M VIDEO AMP	
IC322	XY550A00	IC MM74HC4051SJX	
IC323	X7973A00	IC KIA79M05P1-U	
IC324-325	XS790A00	IC TC74HC4052AF MPX	
IC342	X7818A00	IC LC74782JM-8A16-TLM	

* New Parts

RX-V461/HTR-6040/
RX-V461DAB

P.C.B. VIDEO, P.C.B. HDMI and P.C.B. DAB

Carbon Resistors

Ref. No.	Part No.	Description	Markets
IC343	XY877A00	IC MM74HC4053SJX	
IC344	X6742A00	IC LA73050-TLM-E	
JK301	VS867300	CN. DIN 4P YKF51-5501	
JK302-303	V9273500	CN. DIN 2P YKF51-5605	
PJ321	V7189800	JACK. PIN 1P	
PJ322-323	V7190000	JACK. PIN 2P	
PJ324-325	WG505100	JACK. PIN 6P	
PN381	V9637500	PIN L=70 #18	
Q3201	VV556400	TR 2SC2412K Q, R, S	
Q3401-3402	VV556400	TR 2SC2412K Q, R, S	
R3231	HV754100	R. CAR. FP 10Ω 1/4W	
R3401-3402	HV753100	R. CAR. FP 1Ω 1/4W	
R3416	HV755470	R. CAR. FP 470Ω 1/4W	
R3417	HV753100	R. CAR. FP 1Ω 1/4W	
R3801-3805	HV753220	R. CAR. FP 2.2Ω 1/4W	
ST301-302	WA789600	SCR. TERM M3	
ST322	WA789600	SCR. TERM M3	
TE381	WK560800	TERM. SP 4P MST-204V1-01 NC	T
TE381	WK560900	TERM. SP 4P MST-204V1-01 WC	BGE
TE382	WK561000	TERM. SP 6P MST-207V1-01 NC	T
TE382	WK561100	TERM. SP 6P MST-207V1-01 WC	BGE
XL341	WK196100	RSNR. CRY5 17.734475MHz	
	WJ644800	P. C. B. HDMI	TGE
CB901-903	WH641400	CN. HDMI 19P SE	TGE
CB905	LB919030	CN. BS. PIN 3P	TGE
CB906	VB858200	CN. BS. PIN 3P	TGE
C4902	WD758300	C. CE. CHP 10uF 10V	TGE
C4903-4905	US135100	C. CE. CHP 0.1uF 16V	TGE
C4906	V5333500	C. CE. CHP 10uF 6.3V	TGE
C4907	UF017220	C. EL. CHP 22uF 6.3V	TGE
C4908-4910	US135100	C. CE. CHP 0.1uF 16V	TGE
C4911	V5333500	C. CE. CHP 10uF 6.3V	TGE
C4912-4914	US135100	C. CE. CHP 0.1uF 16V	TGE
C4915	UF037100	C. EL. CHP 10uF 16V	TGE
C4916-4918	US135100	C. CE. CHP 0.1uF 16V	TGE
C4919	UF027220	C. EL. CHP 22uF 10V	TGE
C4920	US135100	C. CE. CHP 0.1uF 16V	TGE
C4921	UF028100	C. EL. CHP 100uF 10V	TGE
C4922	US135100	C. CE. CHP 0.1uF 16V	TGE
C4923	UF028100	C. EL. CHP 100uF 10V	TGE
C4924	US135100	C. CE. CHP 0.1uF 16V	TGE
D4909-4910	WE674800	DIODE AVR161A1R1NTB	TGE
D4912	VT332900	DIODE 1SS355	TGE
D4913-4916	WH641900	ESD PESD0603-140	TGE
D4917-4918	WE674800	DIODE AVR161A1R1NTB	TGE
D4919-4926	WH641900	ESD PESD0603-140	TGE
D4927-4928	WE674800	DIODE AVR161A1R1NTB	TGE
D4929-4932	WH641900	ESD PESD0603-140	TGE
D4933-4934	VT332900	DIODE 1SS355	TGE
D4936-4937	VU171400	DIODE. ZENR UDZS3.3BTE-17 3.3V	TGE
F4901	V2997600	SW. POLY SMDC050-02	TGE
IC902	X7741A00	IC NJM2867F3-05 (TE1)	TGE
IC903	X8900A00	IC CXB1442AR-T4	TGE
IC904	X7854A00	IC SN74LVC3G04DCTR	TGE
IC905	X6869A00	IC NJM2885DL1-33	TGE
IC906	X5896A00	IC SN74LVC1G08DCKR	TGE
IC907	X7743A00	IC SN74CB303257PWR	TGE

* New Parts

Ref. No.	Part No.	Description	Markets
IC908	X4454A00	IC SN74LVC2G17DCKR	TGE
IC909	XP351A00	IC TC7S32FU (TE85L, F)	TGE
IC910	XP001A00	IC TC7S04FU (TE85L, F)	TGE
IC911	X7788A00	IC TC7S86FU (TE85L, F)	TGE
Q4902-4906	VV556400	TR 2SC2412K Q, R, S	TGE
ST901-902	V4040500	SCR. TERM M3	TGE
	WJ644900	P. C. B. DAB	B
CB361	VB858200	CN. BS. PIN 3P	B
CB362	LB919020	CN. BS. PIN 2P	B
CB363	WG222400	CN. BS. PIN 44P TE	B
C3601	US064100	C. CE. CHP 0.01uF 50V B	B
C3602	UR837470	C. EL 47uF 16V	B
C3603	US135100	C. CE. CHP 0.1uF 16V	B
C3604	US135330	C. CE. CHP 0.33uF 16V	B
C3605	UR866100	C. EL 1uF 50V	B
C3606	UR837470	C. EL 47uF 16V	B
C3613-3614	US062220	C. CE. CHP 220pF 50V B	B
C3616-3617	UR238220	C. EL 220uF 16V	B
C3618-3619	US135100	C. CE. CHP 0.1uF 16V	B
C3621	US126100	C. CE. CHP 1uF 10V	B
C3622	US064100	C. CE. CHP 0.01uF 50V B	B
C3623	US126100	C. CE. CHP 1uF 10V	B
C3624	US135100	C. CE. CHP 0.1uF 16V	B
C3625-3626	US064100	C. CE. CHP 0.01uF 50V B	B
IC361	X6143A00	IC NJM2388F05 5.0V	B
IC362	X6248A00	IC NJM2388F33	B
	WG158700	SUPPORT	B

* New Parts

Value	1/4W Type Part No.	1/6W Type Part No.	Value	1/4W Type Part No.	1/6W Type Part No.
1.0 Ω	HJ35 3100	HF85 3100	10 kΩ	HF45 7100	HF45 7100
1.8 Ω	HJ35 3180	*	11 kΩ	HF45 7110	HF45 7110
2.2 Ω	HJ35 3220	HF85 3220	12 kΩ	HJ35 7120	HF85 7120
3.3 Ω	HJ35 3330	HF85 3330	13 kΩ	HF45 7130	HF45 7130
4.7 Ω	HJ35 3470	HF85 3470	15 kΩ	HF45 7150	HF45 7150
5.6 Ω	HJ35 3560	HF85 3560	18 kΩ	HF45 7180	HF45 7180
10 Ω	HF45 4100	HF45 4100	22 kΩ	HF45 7220	HF45 7220
15 Ω	HJ35 4150	HF85 4150	24 kΩ	HF45 7240	HF45 7240
22 Ω	HF45 4220	HF45 4220	27 kΩ	HJ35 7270	HF85 7270
27 Ω	HJ35 4270	HF85 4270	30 kΩ	HF45 7300	HF45 7300
33 Ω	HF45 4330	HF45 4330	33 kΩ	HF45 7330	HF45 7330
39 Ω	HJ35 4470	HF85 4390	36 kΩ	HF45 7360	HF45 7360
47 Ω	HF45 4470	HF45 4470	39 kΩ	HF45 7390	HF45 7390
56 Ω	HF45 4560	HF45 4560	47 kΩ	HF45 7470	HF45 7470
68 Ω	HF45 4680	HF45 4680	51 kΩ	HF45 7510	HF45 7510
75 Ω	HF45 4750	HF45 4750	56 kΩ	HF45 7560	HF45 7560
82 Ω	HF45 4820	HF45 4820	62 kΩ	HF45 7620	HF45 7620
91 Ω	HF45 4910	HF45 4910	68 kΩ	HF45 7680	HF45 7680
100 Ω	HF45 5100	HF45 5100	82 kΩ	HF45 7820	HF45 7820
110 Ω	HJ35 5110	HF85 5110	91 kΩ	HF45 7910	HF45 7910
120 Ω	HF45 5120	HF45 5120	100 kΩ	HF45 8100	HF45 8100
150 Ω	HF45 5150	HF45 5150	110 kΩ	HF45 8110	HF45 8110
160 Ω	HJ35 5160	*	120 kΩ	HF45 8120	HF45 8120
180 Ω	HF45 5180	HF45 5180	150 kΩ	HF45 8150	HF45 8150
200 Ω	HF45 5200	HF45 5200	180 kΩ	HF45 8180	HF45 8180
220 Ω	HF45 5220	HF45 5220	220 kΩ	HJ35 8220	HF85 8220
270 Ω	HF45 5270	HF45 5270	270 kΩ	HF45 8270	HF45 8270
330 Ω	HF45 5330	HF45 5330	300 kΩ	HF45 8300	HF45 8300
390 Ω	HF45 5390	HF45 5390	330 kΩ	HF45 8330	HF45 8330
430 Ω	HF45 5430	HF45 5430	390 kΩ	HJ35 8390	HF85 8390
470 Ω	HF45 5470	HF45 5470	470 kΩ	HF45 8470	HF45 8470
510 Ω	HF45 5510	HF45 5510	560 kΩ	HJ35 8560	HF85 8560
560 Ω	HF45 5560	HF45 5560	680 kΩ	HJ35 8680	HF85 8680
680 Ω	HF45 5680	HF45 5680	820 kΩ	HJ35 8820	HF85 8820
820 Ω	HF45 5820	HF45 5820	1.0 MΩ	HF45 9100	HF45 9100
910 Ω	HF45 5910	HF45 5910	1.2 MΩ	HJ35 9120	*
1.0 kΩ	HF45 6100	HF45 6100	1.5 MΩ	HJ35 9150	HF85 9150
1.2 kΩ	HF45 6120	HF45 6120	1.8 MΩ	HJ35 9180	HF85 9180
1.5 kΩ	HF45 6150	HF45 6150	2.2 MΩ	HJ35 9220	HF85 9220
1.8 kΩ	HF45 6180	HF45 6180	3.3 MΩ	HJ35 9330	HF85 9330
2.0 kΩ	HJ35 6200	HF85 6200	3.9 MΩ	HJ35 9390	*
2.2 kΩ	HF45 6220	HF45 6220	4.7 MΩ	HJ35 9470	HF85 9470
2.4 kΩ	HJ35 6240	HF85 6240			
2.7 kΩ	HF45 6270	HF45 6270			
3.0 kΩ	HF45 6300	HF45 6300			
3.3 kΩ	HF45 6330	HF45 6330			
3.6 kΩ	HJ35 6360	HF85 6360			
3.9 kΩ	HF45 6390	HF45 6390			
4.7 kΩ	HF45 6470	HF45 6470			
5.1 kΩ	HF45 6510	HF45 6510			
5.6 kΩ	HF45 6560	HF45 6560			
6.8 kΩ	HF45 6680	HF45 6680			
8.2 kΩ	HF45 6820	HF45 6820			
9.1 kΩ	HF45 6910	HF45 6910			

* : Not available

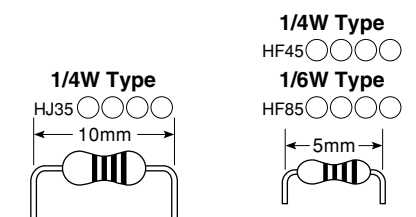

• OVERALL ASS'Y

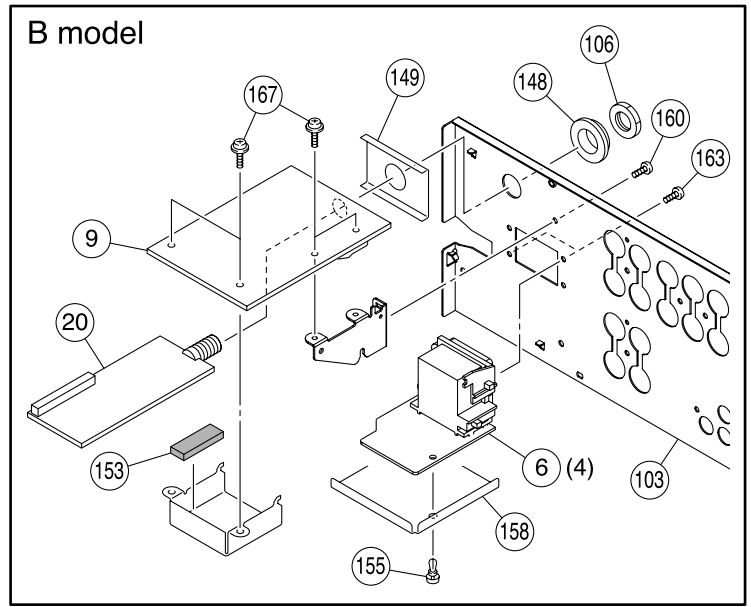
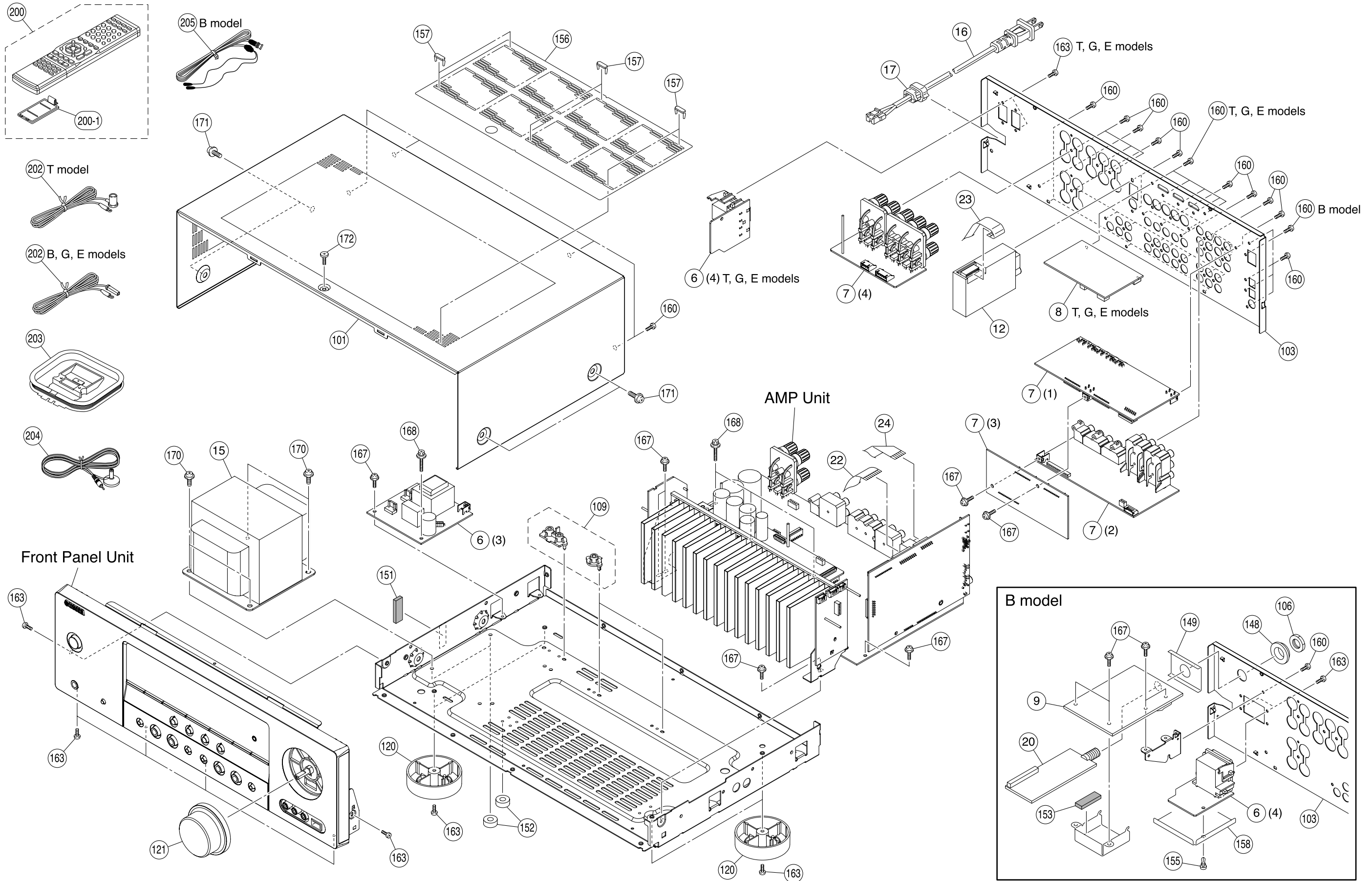

1
2
3
4
5
6
7

Ref. No.	Part No.	Description	Remarks	Markets	
*	6	WK038800	P. C. B. ASS' Y	OPERATION	T
*	6	WK039100	P. C. B. ASS' Y	OPERATION	B
*	6	WK038900	P. C. B. ASS' Y	OPERATION	GE
*	7	WK038300	P. C. B. ASS' Y	VIDEO	T
*	7	WJ641700	P. C. B. ASS' Y	VIDEO	B
*	7	WK038400	P. C. B. ASS' Y	VIDEO	GE
*	8	WJ644800	P. C. B. ASS' Y	HDMI	TGE
*	9	WJ644900	P. C. B. ASS' Y	DAB	B
	12	WB877300	AM/FM TUNER	FAE381-A07F	T
	12	WB424100	AM/FM TUNER	ENG07711Q	BGE
⚠	15	X8608A00	POWER TRANSFORMER		T
*	15	X8610A00	POWER TRANSFORMER		BGE
⚠	16	WB120600	POWER CABLE	2m	T
⚠	16	WB212200	POWER CABLE	2m	B
⚠	16	WB212300	POWER CABLE	2m	GE
	17	V2438700	CORD STOPPER	10P1	
	20	WG233000	DAB MODULE	VENICE3.0-C-F	B
	22	MF120180	FLEXIBLE FLAT CABLE	20P 180mm P=1.25	
	23	MF113120	FLEXIBLE FLAT CABLE	13P 120mm P=1.25	
	24	MF114100	FLEXIBLE FLAT CABLE	14P 100mm P=1.25	
	101	WE065200	TOP COVER	GD	
	101	WE065000	TOP COVER	BL	
	101	WE065100	TOP COVER	TI	
	101	WG481900	TOP COVER	SI	
*	103	WJ185000	REAR PANEL	V461	T
*	103	WJ185300	REAR PANEL	V461	GE
*	103	WJ185900	REAR PANEL	6040	T
*	103	WJ186100	REAR PANEL	6040	GE
*	103	WJ185200	REAR PANEL	V461DAB	B
	106	WG205000	NUT	3/8 UNEF-32	B
	109	WA796100	SUPPORT P. C. B.		
	120	WA790600	LEG	D60/H21 GD	GD
	120	WA790500	LEG	D60/H21 HS	V461BL, V461DAB BL, TI, SI
	120	WA790700	LEG	D60/H21 BL	6040BL
	121	WG362100	KNOB D48		GD
	121	WG362000	KNOB D48		BL
	121	WG466100	KNOB D48		TI
	121	WG362200	KNOB D48		SI
*	148	WM283900	WASHER DAB	D18/9.6 t=2.7	B
*	149	WM284000	SHEET DAB		B
	151	WB408400	DAMPER	10x30 t=4	
	152	WB484700	DAMPER	SCREW MASK	
	153	WJ992300	DAMPER	4x10x30	B
	155	VQ368600	PUSH RIVET	P3555-B	B
	156	WJ589800	SHEET TOP		
	157	WJ323900	RIVET TOP		
*	158	WK542800	SHEET OUTLET		B
	160	WE774100	BIND HEAD BONDING B-T. SCREW	3x8 MFZN2B3	
	163	WE774300	BIND HEAD B-TIGHT SCREW	3x8 MFZN2W3	
	167	WF002600	PW HEAD B-TIGHT SCREW	3x8 MFZN2W3	
	168	WE774600	SCREW IC	3x18 MFZN2W3	
	170	WE774700	BIND HEAD S-TIGHT SCREW	4x10 MFZN2W3	
	171	VD069600	PW HEAD S-TIGHT SCREW	4x8-10 MFN133	GD, TI, SI
	171	VH313200	PW HEAD S-TIGHT SCREW	4x8-10 MFN13BL	BL
	172	WE200400	DISH HEAD B-TIGHT SCREW	3x6 MFN133	GD, TI, SI
	172	WE200500	DISH HEAD B-TIGHT SCREW	3x6 MFN13BL	BL

* New Parts

Ref. No.	Part No.	Description	Remarks	Markets	
*	200	WK227300	ACCESSORIES		
	200	WJ409200	REMOTE CONTROL	RAV315	TGE
	200-1	AAX82380	REMOTE CONTROL	RAV310	B
	200-1	AAX82380	BATTERY COVER		CG-2209
	202	WB212500	INDOOR FM ANTENNA	1.4m 1pc	T
	202	WB212400	INDOOR FM ANTENNA	1.4m 1pc	BGE
	203	WB212600	AM LOOP ANTENNA	1.0m 1pc	
	204	WJ264300	OPTIMIZER MICROPHONE	6m 1pc	
*	205	WK532000	DAB WIRE ANTENNA	1.6m 1pc	B
			BATTERY	R03, AAA, UM-4 2pcs	
			SERVICE TOOL		
		V2854400	FLEXIBLE FLAT CABLE	17P 300mm P=1.25	

* New Parts

• FRONT PANEL UNIT

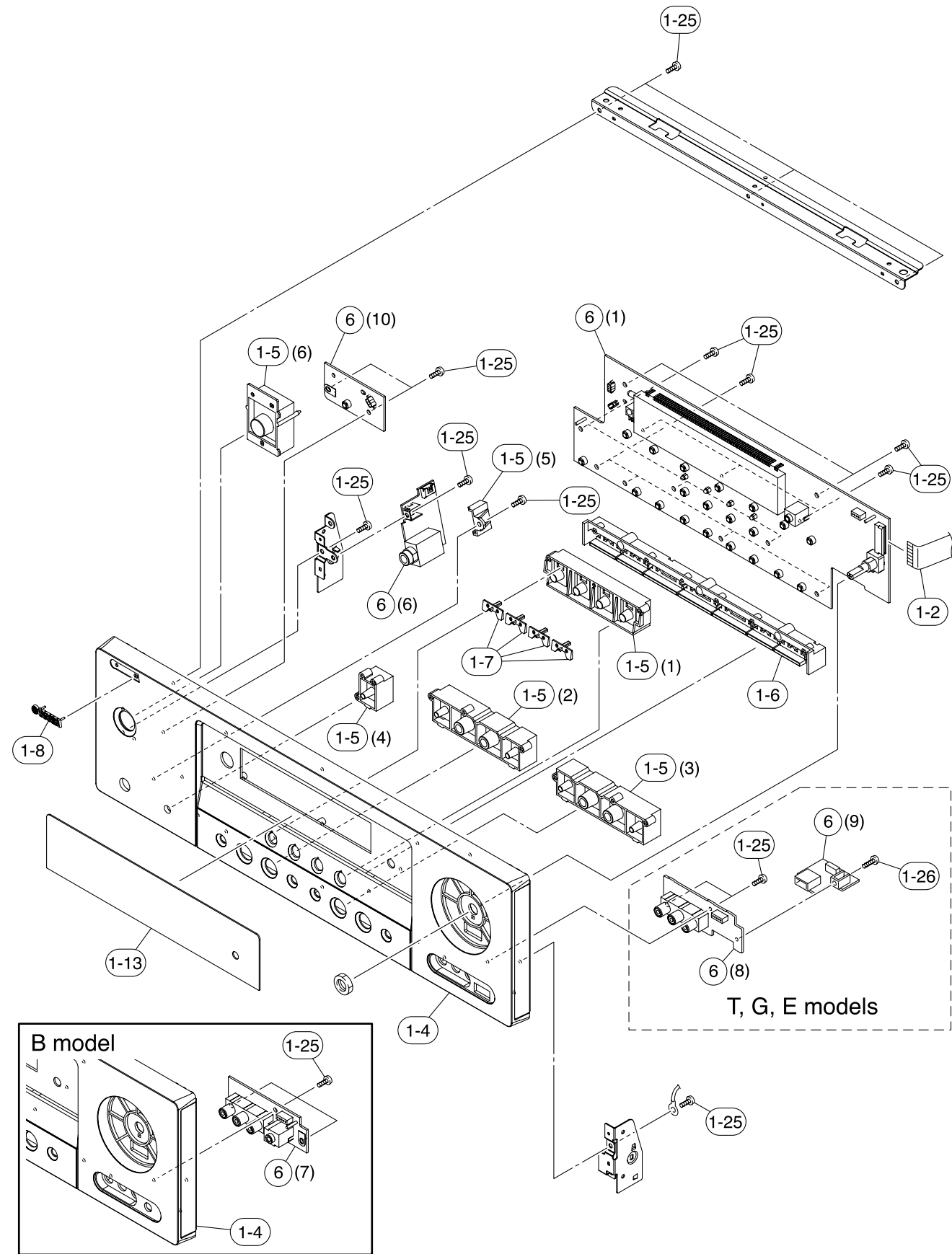

Ref. No.	Part No.	Description	Remarks	Markets
1-2	MF117180	FLEXIBLE FLAT CABLE	17P 180mm P=1.25	
* 1-4	WK122600	FRONT PANEL		V461GD
* 1-4	WK122800	FRONT PANEL		6040GD
* 1-4	WJ310000	FRONT PANEL		V461BL
* 1-4	WJ310200	FRONT PANEL		6040BL
* 1-4	WJ188200	FRONT PANEL		V461DAB BL
* 1-4	WJ310100	FRONT PANEL		V461TI
* 1-4	WJ189200	FRONT PANEL		V461DAB TI
* 1-4	WJ310400	FRONT PANEL		6040SI
1-5	WJ192500	BUTTON CASE		GD
1-5	WJ192300	BUTTON CASE		V461BL, V461DAB BL
1-5	WJ192400	BUTTON CASE		6040BL
1-5	WJ192700	BUTTON CASE		TI
1-5	WJ192600	BUTTON CASE		SI
1-6	WJ192800	BUTTON TUNER		
1-7	WJ193200	LENS BUTTON	SCENE	
1-8	WJ193400	EMBLEM	GOLD	GD, 6040BL
1-8	WJ193300	EMBLEM	BLACK	V461BL, V461DAB BL, TI, SI
* 1-13	WJ193900	SHEET WINDOW		V461, 6040GD, 6040SI
* 1-13	WJ456500	SHEET WINDOW		6040BL
* 1-13	WJ193700	SHEET WINDOW		V461DAB
1-25	WE774800	BIND HEAD P-TIGHT SCREW	3x8 MFZN2W3	
1-26	WF268000	BIND HEAD P-TIGHT SCREW	3x10 MFZN2B3	
6	WK038800	P. C. B. ASS'Y	OPERATION	TGE
6	WK039100	P. C. B. ASS'Y	OPERATION	B
6	WK038900	P. C. B. ASS'Y	OPERATION	GE

* New Parts

1 • AMP UNIT

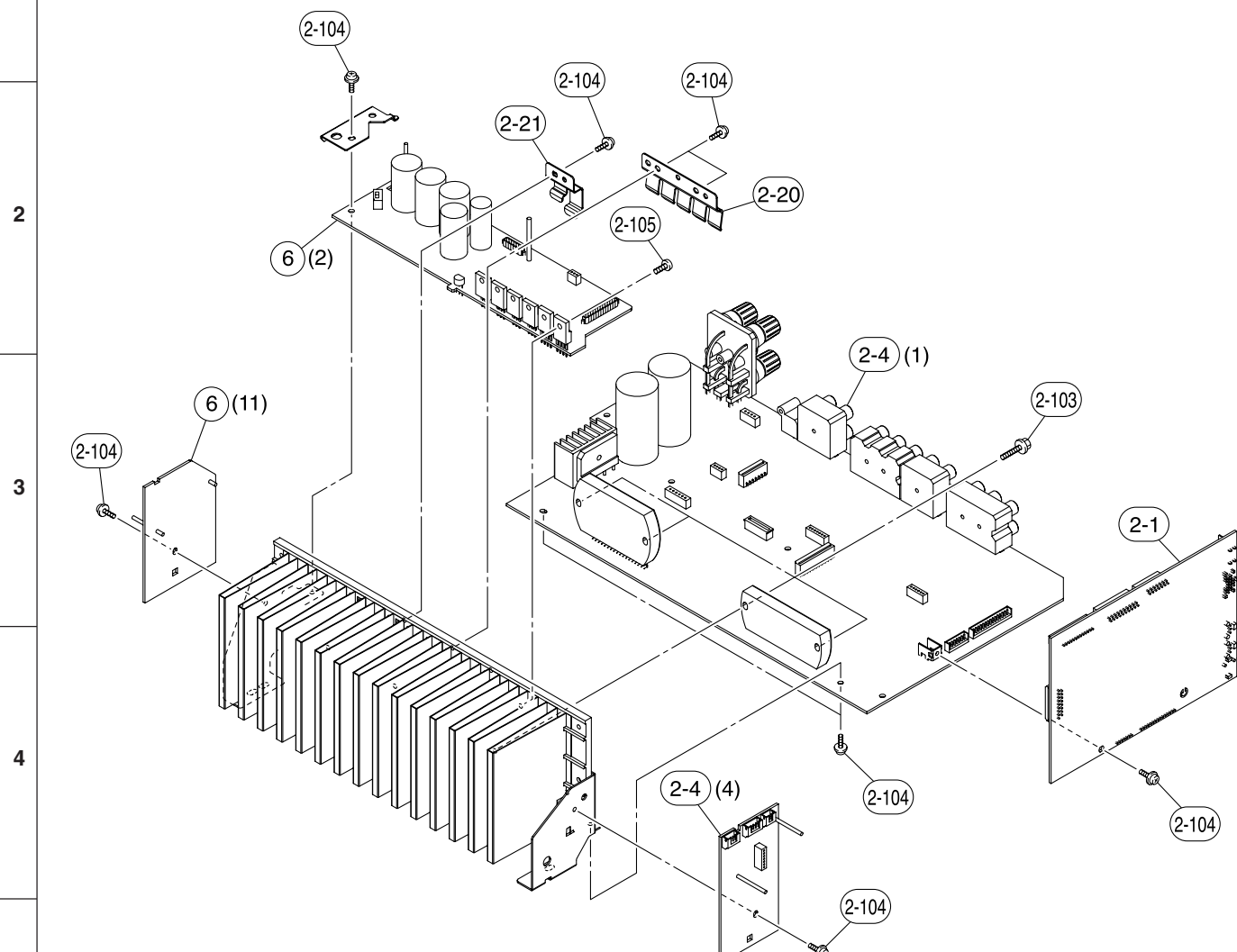

Ref. No.	Part No.	Description	Remarks	Markets	
*	2-1	WK038500	P. C. B. ASS'Y	DSP	T
*	2-1	WK038700	P. C. B. ASS'Y	DSP	B
*	2-1	WK038600	P. C. B. ASS'Y	DSP	GE
*	2-4	WK038000	P. C. B. ASS'Y	MAIN	T
*	2-4	WK038200	P. C. B. ASS'Y	MAIN	B
*	2-4	WK038100	P. C. B. ASS'Y	MAIN	GE
	2-20	WG451000	SUPPORT TR	5P	
	2-21	WJ187700	SUPPORT TR	2P	
	2-103	WE774600	SCREW IC	3x18 MFZN2W3	
	2-104	WF002600	PW HEAD B-TIGHT SCREW	3x8 MFZN2W3	
	2-105	WE774300	BIND HEAD B-TIGHT SCREW	3x8 MFZN2W3	
*	6	WK038800	P. C. B. ASS'Y	OPERATION	T
*	6	WK039100	P. C. B. ASS'Y	OPERATION	B
*	6	WK038900	P. C. B. ASS'Y	OPERATION	GE

* New Parts

REMOTE CONTROL

- RAV315 (T, G, E models), RAV310 (B model)
- SCHEMATIC DIAGRAM

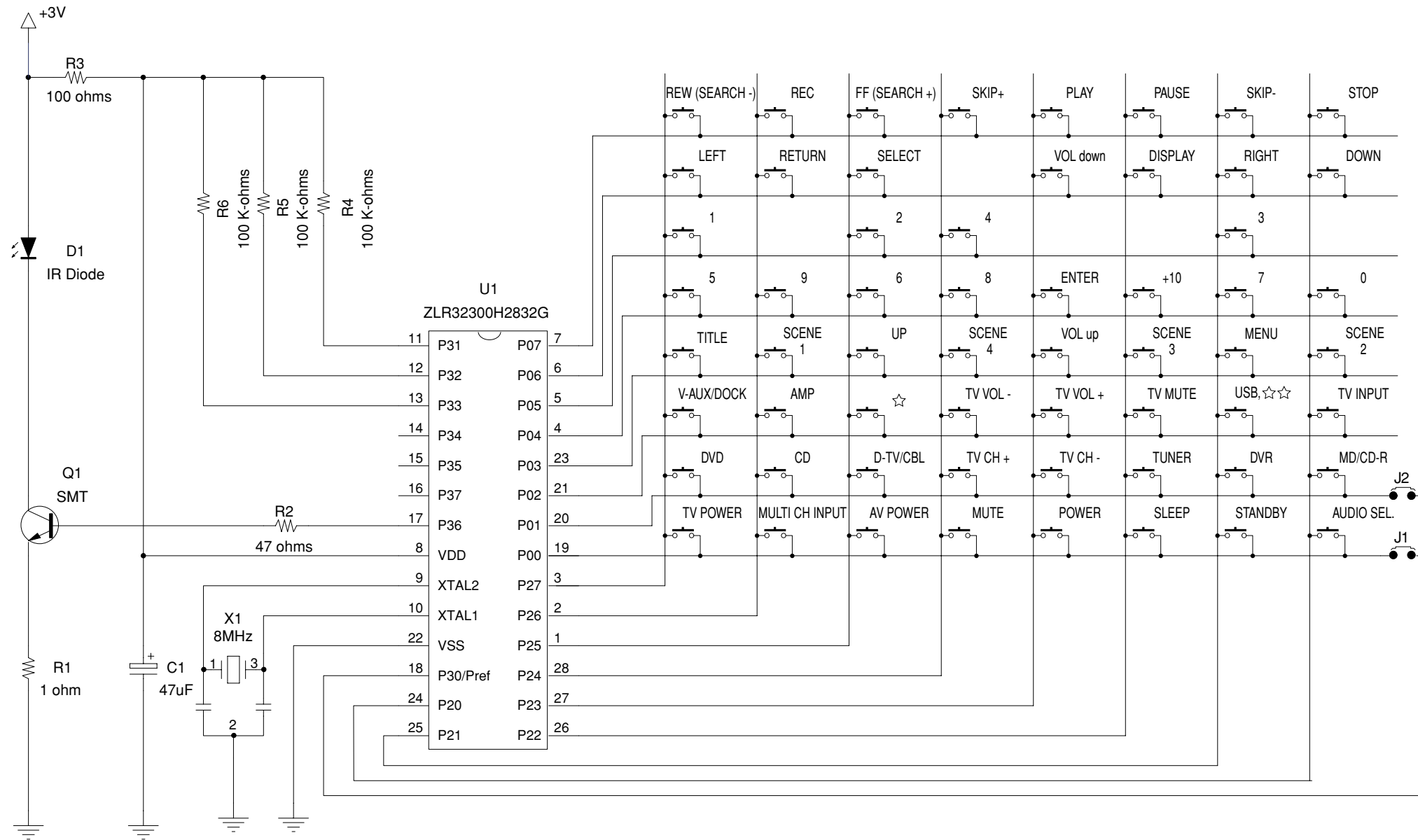

PANEL

RAV315
 RX-V461 (T, G, E models)
 HTR-6040 (T, G, E models)

RAV310
 RX-V461DAB (B model)

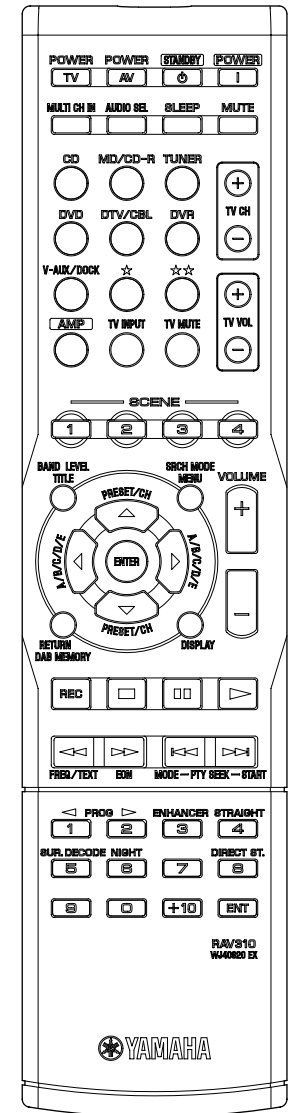
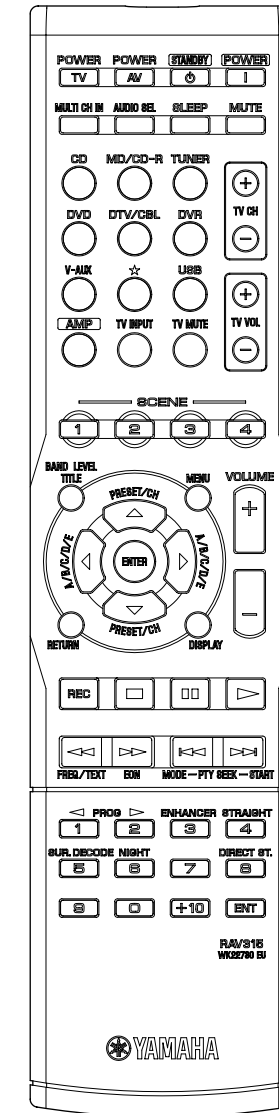

	RAV315	RAV310
J1	X	O
J2	O	X

1 • KEY NO. LAYOUT

• KEY CODE

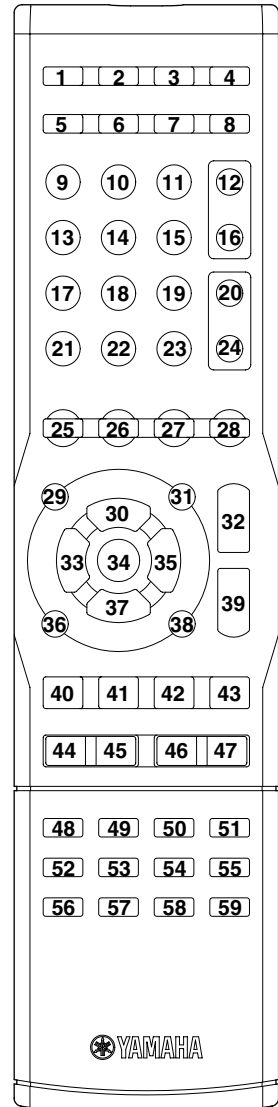

Key No.	Label	Command Key	YAMAHA signal													
			AMP	(TV Power)	(TV Power)	(TV Power)	(TV Power)	(DVR Power)	(TV Power)	(TV Power)	(TV Power)	(TV Power)	(TV Power)	(TV Power)		
1	TV POWER	-	-	(TV Power)	(TV Power)	(TV Power)	(TV Power)	-	(TV Power)	(TV Power)	(TV Power)	(TV Power)	(TV Power)	(TV Power)		
2	AV POWER	-	-	-	7F80	-	7F80	(DVR Power)	048.012	7F01-00	-	-	7F01-20	(TV Power)		
3	STANDBY	O	7E-7F	STANDBY												
4	POWER	O	7E-7E	POWER ON												
5	MULTI CH INPUT	O	7A-87	MULTI CH INPUT												
6	AUDIO SEL.	O	7A-C3	AUDIO SELECT												
7	SLEEP	O	7A-57	SLEEP												
8	MUTE	O	7A-1C	MUTE												
9	CD	O	7A-15	<INPUT key>	Output IR signal and change Device mode										Library	brand
10	MD/CD-R	O	7A-C9	<INPUT key>	Output IR signal and change Device mode										CD	YAMAHA-1
11	TUNER	O	7A-16	<INPUT key>	Output IR signal and change Device mode										CD-R	YAMAHA
12	TV CH +	-	-	(TV CH +)	(TV CH +)	(TV CH +)	(TV CH +)	-	(TV CH +)	(TV CH +)	(TV CH +)	(TV CH +)	(TV CH +)	(TV CH +)	(TV CH +)	
13	DVD	O	7A-C1	<INPUT key>	Output IR signal and change Device mode										TUNER	YAMAHA-2
14	D-TV/CBL	O	7A-54	<INPUT key>	Output IR signal and change Device mode										DVD	YAMAHA-1
15	DVR	O	7A-13	<INPUT key>	Output IR signal and change Device mode										TV	-
16	TV CH -	-	-	(TV CH -)	(TV CH -)	(TV CH -)	(TV CH -)	-	(TV CH -)	(TV CH -)	(TV CH -)	(TV CH -)	(TV CH -)	(TV CH -)	(TV CH -)	
17	V-AUX / DOCK	O	7A-55	<INPUT key>	Output IR signal and change Device mode										DVR	YAMAHA
18	☆	O	7A-B4	<INPUT key>	Output IR signal and change Device mode										TUNER (RAV315)	YAMAHA-6
19	USB	O	-	<INPUT key>	Output IR signal and change Device mode										TUNER (RAV315)	YAMAHA-4
	☆ ☆															
20	TV VOL +	-	-	(TV VOL +)	(TV VOL +)	(TV VOL +)	(TV VOL +)	-	(TV VOL +)	(TV VOL +)	(TV VOL +)	(TV VOL +)	(TV VOL +)	(TV VOL +)	(TV VOL +)	
21	AMP	O	-	Change to AMP mode												
			Key No Mode	9	10	11	13	14	15	17	18	19	21			
				CD	MD/CD-R	TUNER	DVD	D-TV/CBL	DVR	V-AUX/DOCK	☆ (RAV315)	☆ (RAV310)	USB (RAV315)	☆☆ (RAV310)	AMP	
22	TV INPUT	-	-	(TV Input)	(TV Input)	(TV Input)	(TV Input)	-	(TV Input)	(TV Input)	(TV Input)	(TV Input)	(TV Input)	(TV Input)		
23	TV MUTE	-	-	(TV Mute)	(TV Mute)	(TV Mute)	(TV Mute)	-	(TV Mute)	(TV Mute)	(TV Mute)	(TV Mute)	(TV Mute)	(TV Mute)		
24	TV VOL -	-	-	(TV VOL -)	(TV VOL -)	(TV VOL -)	(TV VOL -)	-	(TV VOL -)	(TV VOL -)	(TV VOL -)	(TV VOL -)	(TV VOL -)	(TV VOL -)		
25	SCENE 1	O	7A-007F	SCENE SELECT												
26	SCENE 2	O	7A-037C	SCENE SELECT												
27	SCENE 3	O	7A-0679	SCENE SELECT												
28	SCENE 4	O	7A-0976	SCENE SELECT												
29	TITLE	-	-	-	-	7A-AE	7CB1	-	048.200	7F01-0D	7A-70	-	7F01-2D	-	7A-86	
30	UP	-	-	-	-	7A-10	7CB4	-	048.088	7F01-0E	7A-6A	-	7F01-2E	-	7A-9D	
31	MENU	-	-	-	-	7A-AB	7CB2	-	048.084	7F01-0F	7A-6D	-	7F01-2F	-	7A-84	
32	VOL up	O	7A-1A	VOL UP												
33	LEFT	-	-	-	-	7A-AC	7CB5	-	048.090	7F01-10	7A-6E	-	7F01-30	-	7A-9F	
34	SELECT	-	-	-	-	7A-AD	7CB8	-	048.092	7F01-11	7A-6F	-	7F01-31	-	7A-DE	
35	RIGHT	-	-	-	-	7A-12	7CB6	-	048.091	7F01-12	7A-6C	7A06	7F01-32	-	7A-9E	
36	RETURN	-	-	-	-	7A-AF	7CB7	-	048.131	7F01-13	7A-71	-	7F01-33	-	7A-AA	
37	DOWN	-	-	-	-	7A-11	7CB3	-	048.089	7F01-14	7A-6B	-	7F01-34	-	7A-9C	
38	DISPLAY	-	-	790A	7F9E	7A-B0	7CA6	-	048.015	7F01-15	7A-72	-	7F01-35	7C13	7A-C2	
39	VOL down	O	7A-1B	VOL DOWN												
40	REC	-	-	7A4F	-	-	7C8B	(DVR REC)	048.055	7F01-16	-	7A04	7F01-36	-	(device)	
41	STOP	-	-	7A09	7F84	-	7C85	(DVR Stop)	048.049	7F01-1D	-	7A03	7F01-3D	7C5B	(device)	
42	PAUSE	-	-	7A09	7F83	-	7C83	(DVR Pause)	048.048	7F01-1A	-	-	7F01-3A	7C5A	(device)	
43	PLAY	-	-	7A08	7F82	-	7C82	(DVR Play)	048.044	7F01-1E	-	7A00	7F01-3E	7C05	(device)	
44	REW (SEARCH -)	-	-	7A0D	7F88	7A-A4	7C86	(DVR REW)	048.041	7F01-17	-	7A01	7F01-37	7C06	(device)	
45	FF (SEARCH +)	-	-	7A0C	7F89	7A-A5	7C87	(DVR FF)	048.040	7F01-18	-	7A02	7F01-38	7C07	(device)	
46	SKIP -	-	-	7A0B	7F86	7A-A6	7CB9		048.033	7F01-1B	-	7A07	7F01-3B	7C02	(device)	
47	SKIP +	-	-	7A0A	7F87	7A-A7	7CBA		048.032	7F01-1C	-	7A40	7F01-3C	7C03	(device)	
48	1	-	-	7911	7F91	7A-E5	7C94	-	048.001	7F01-01	7A-61	-	7F01-21	7C17	7A-59	
49	2	-	-	7912	7F92	7A-E6	7C95	-	048.002	7F01-02	7A-62	-	7F01-22	7C18	7A-58	
50	3	-	-	7913	7F93	7A-E7	7C96	-	048.003	7F01-03	7A-63	-	7F01-23	7C19	7A-94	
51	4	-	-	7914	7F94	7A-E8	7C97	-	048.004	7F01-04	7A-64	-	7F01-24	7C1A	7A-56	
52	5	-	-	7915	7F95	7A-E9	7C98	-	048.005	7F01-05	7A-65	-	7F01-25	7C1B	7A-8D	
53	6	-	-	7916	7F96	7A-EA	7C99	-	048.006	7F01-06	7A-66	-	7F01-26	7C1C	7A-95	
54	7	-	-	7917	7F97	7A-EB	7C9A	-	048.007	7F01-07	7A-67	-	7F01-27	7C1D	-	
55	8	-	-	7918	7F98	7A-EC	7C9B	-	048.008	7F01-08	7A-68	-	7F01-28	7C1E	7A-DD	
56	9	-	-	7919	7F99	7A-B1	7C9C	-	048.009	7F01-09	7A-69	-	7F01-29	7C1F	-	
57	0	-	-	7910	7F90	7A-B2	7C93	-	048.000	7F01-0A	7A-60	-	7F01-2A	7C16	-	
58	+10	-	-	791A	7F9A	-	7C9D	-	-	7F01-0B	-	-	7F01-2B	7C5D	-	
59	ENTER	-	-	790B	7F8A	7A-B3	7C9E	-	-	7F01-0C	7A-BF	-	7F01-2C	7C15	-	

7

Advanced setup

This unit has additional menus that are displayed in the front panel display. The advanced setup menu offers additional operations to adjust and customize the way this unit operates. Change the initial settings (indicated in bold under each parameter) to reflect the needs of your listening environment.

Notes

- Only **STANDBY/ON** and **STRAIGHT** are effective while you are using the advanced setup menu.
- No other operations can be made while you are using the advanced setup menu.
- The advanced setup menu is only available in the front panel display.

1 Press **STANDBY/ON** on the front panel to set this unit to the standby mode.

2 Press and hold **TONE CONTROL** and then press **STANDBY/ON** to turn on this unit.

This unit turns on, and the advanced setup menu appears in the front panel display.

3 Press **STRAIGHT** repeatedly to change the selected parameter setting.

4 Press **STANDBY/ON** to confirm your selection and set this unit to the standby mode.



The settings you made are reflected next time you turn on this unit.

■ Factory presets PRESET

Use this feature to reset all the parameters of this unit to the initial factory settings.

Choices: **CANCEL**, **RESET**

- Select “CANCEL” not to reset any parameters of this unit.
- Select “RESET” to reset the parameters of this unit.

Notes

- This setting completely resets all the parameters of this unit including the “SET MENU” parameters. However, the advanced setup menu parameters will not be initialized.
- The initial factory settings are activated next time you turn on this unit.

RX-V461/HTR-6040/ RX-V461DAB



ADVANCED
OPERATION

English